

# In-Line Intermediate Discharge Gates

Installation Manual

PNEG-765

Date: **12-21-20**

GSI GROUP



PNEG-765



# Contents

<b>Chapter 1 Safety</b> .....	<b>4</b>
Safety Guidelines .....	4
Safety Instructions .....	5
<b>Chapter 2 Decal</b> .....	<b>7</b>
<b>Chapter 3 Installation</b> .....	<b>8</b>
Overall Gate Dimensions .....	8
Cut Out Discharge Hole in Trough Bottom .....	9
Manual Gate Installation .....	10
Motor Driven Gate Installation .....	11
Install Gate Frame to Trough .....	15
<b>Chapter 4 Wiring Diagram</b> .....	<b>16</b>
Typical Wiring Diagram .....	16
<b>Chapter 5 Warranty</b> .....	<b>17</b>

### Safety Guidelines

This manual contains information that is important for you, the owner/operator, to know and understand. This information relates to protecting **personal safety** and **preventing equipment problems**. It is the responsibility of the owner/operator to inform anyone operating or working in the area of this equipment of these safety guidelines. To help you recognize this information, we use the symbols that are defined below. Please read the manual and pay attention to these sections. Failure to read this manual and its safety instructions is a misuse of the equipment and may lead to serious injury or death.



**This is the safety alert symbol. It is used to alert you to potential personal injury hazards. Obey all safety messages that follow this symbol to avoid possible injury or death.**



**DANGER** indicates a hazardous situation which, if not avoided, will result in death or serious injury.



**WARNING** indicates a hazardous situation which, if not avoided, could result in death or serious injury.



**CAUTION**, used with the safety alert symbol, indicates a hazardous situation which, if not avoided, could result in minor or moderate injury.



**NOTICE** is used to address practices not related to personal injury.

## Safety Instructions

Our foremost concern is your safety and the safety of others associated with this equipment. We want to keep you as a customer. This manual is to help you understand safe operating procedures and some problems that may be encountered by the operator and other personnel.

As owner and/or operator, it is your responsibility to know what requirements, hazards, and precautions exist, and to inform all personnel associated with the equipment or in the area. Safety precautions may be required from the personnel. Avoid any alterations to the equipment. Such alterations may produce a very dangerous situation where **SERIOUS INJURY** or **DEATH** may occur.

This equipment shall be installed in accordance with the current installation codes and applicable regulations, which should be carefully followed in all cases. Authorities having jurisdiction should be consulted before installations are made.

### Follow Safety Instructions

Carefully read all safety messages in this manual and safety signs on your machine. Keep signs in good condition. Replace missing or damaged safety signs. Be sure new equipment components and repair parts include the current safety signs. Replacement safety signs are available from the manufacturer.

Learn how to operate the machine and how to use controls properly. Do not let anyone operate without instruction.

Keep your machinery in proper working condition. Unauthorized modifications to the machine may impair the function and/or safety and affect machine life.

If you do not understand any part of this manual or need assistance, contact your dealer.

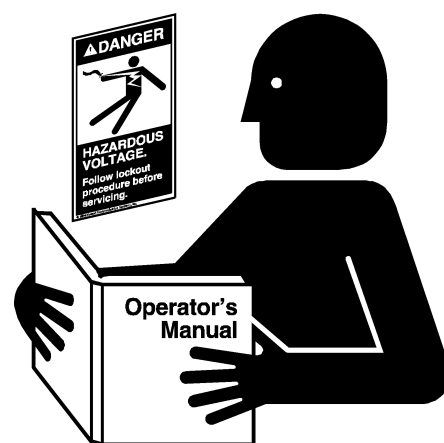

### Read and Understand Manual

### Install and Operate Electrical Equipment Properly

Electrical controls should be installed by a qualified electrician and must meet the standards set by the National Electrical Code and all local and state codes.

Disconnect and lock out all power sources before installing wires/cables or servicing equipment.



### Electric Shock Hazard

# 1. Safety

## Stay Clear of Moving Parts

Keep arms and hands away from slide gate opening. Slide gate can crush and dismember. Motor may start at any time.

Always stop and lock out power source before making adjustments, cleaning, or maintaining equipment.

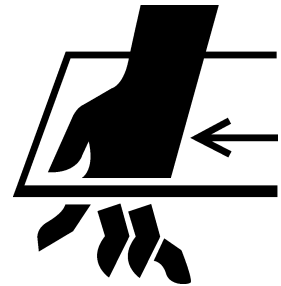

**Slide Hazard**

## Prepare for Emergencies

Be prepared if fire starts.

Keep a first aid kit and fire extinguisher handy.

Keep emergency numbers for doctors, ambulance service, hospital, and fire department near your telephone.

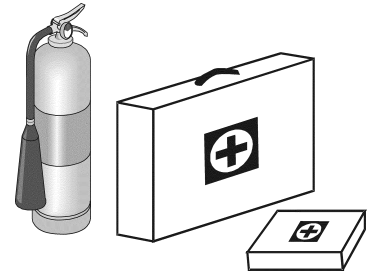

**Keep Emergency Equipment Quickly Accessible**

## Wear Protective Clothing

Wear close-fitting clothing and safety equipment appropriate to the job.

Remove all jewelry.

Tie long hair up and back.

Wear safety glasses at all times to protect eyes from debris.

Wear gloves to protect your hands from sharp edges on plastic or steel parts.

Wear steel-toed boots to help protect your feet from falling debris. Tuck in any loose or dangling shoestrings.

A respirator may be needed to prevent breathing potentially toxic fumes and dust.

Wear a hard hat to help protect your head.

Wear appropriate fall protection equipment when working at elevations greater than six feet (6').

**Eye Protection**

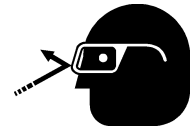

**Gloves**



**Steel-Toed Boots**



**Respirator**



**Hard Hat**



**Fall Protection**



Please remember, safety decals provide important safety information for people working near equipment that is in operation. If a safety sign cannot be easily read for any reason or has been painted over, replace it immediately. Additional safety signs may be obtained from your dealer, distributor or ordered from the factory free of charge.

**Contact:**

The GSI Group  
1004 E. Illinois St.  
Assumption, IL. 62510  
Phone: 1-217-226-4421

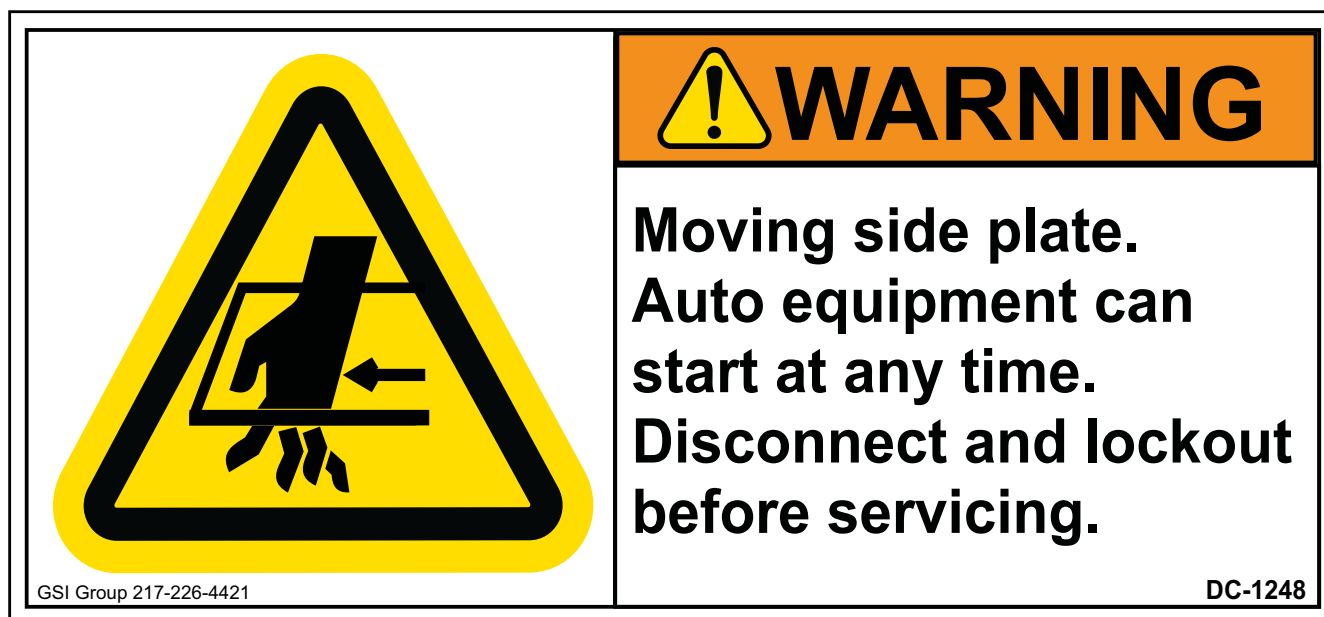

DC-1248  
(Not to scale.)

## Overall Gate Dimensions

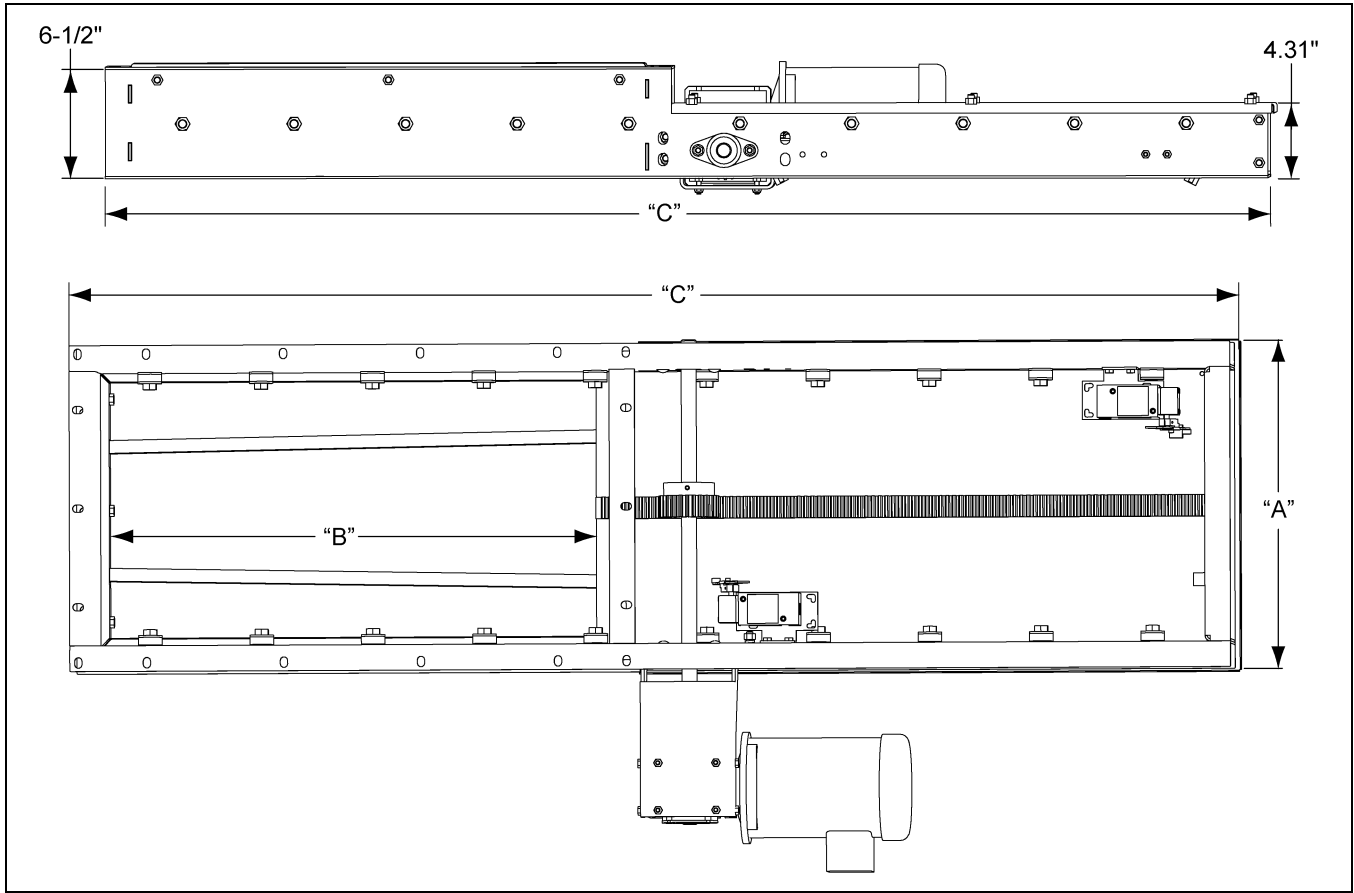

Figure 3A Overall Gate Dimensions

Overall Gate Dimensions

Conveyor Size	"A"	"B"	"C"
0912	9.00	30.00	68.125
1212	12.00	30.00	68.125
1612	16.00	30.00	68.125
1214	12.00	30.00	68.125
1614	16.00	30.00	68.125
2114	21.00	30.00	68.125
1420	14.00	36.00	81.125
1620	16.00	36.00	81.125
2020	20.00	36.00	81.125
2620	26.00	36.00	81.125
3220	32.00	36.00	81.125



## Cut Out Discharge Hole in Trough Bottom

**NOTE:** Gates have slotted holes for slight adjustment.

1. Determine the location of the discharge and identify the specific intermediate section that must be modified to mount the gate.
2. Measure from the intermediate flange connection and mark the centerline of the discharge on the intermediate bottom (dimension "A"). (See Figure 3B.)
3. Refer to the trough hole dimensions chart for the required cut size for the gate opening, dimensions "B" and "C". Dimensional values are centered around the discharge location, dimension "D" can be used as a reference.
4. Mark the opening outline on the intermediate bottom and verify the size with the gate opening prior to cutting the material.
5. Clean up the cut with a grinder to remove burrs and rough edges. The gate's carry-over bar frame must be able to fit inside the opening.

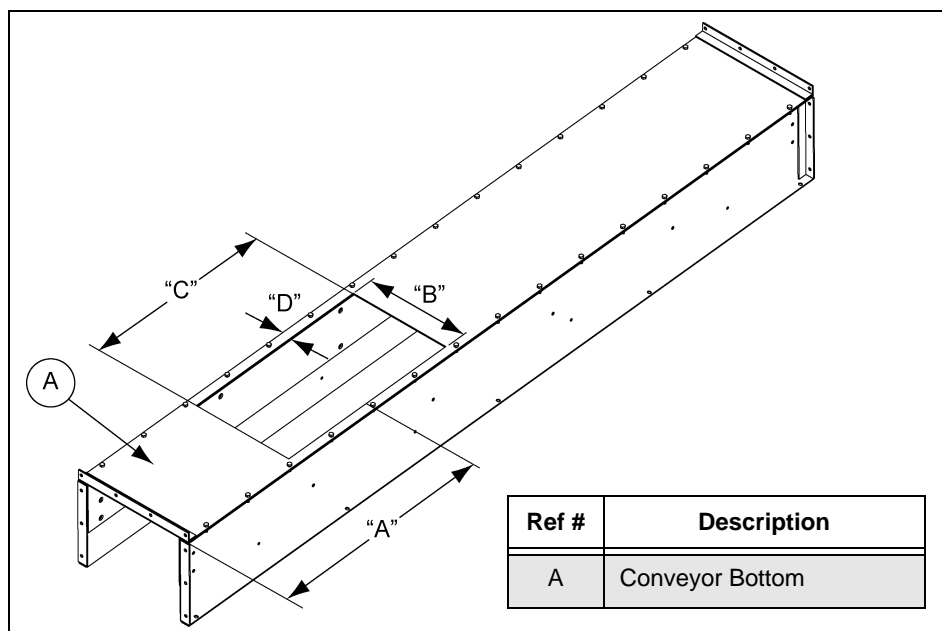

Figure 3B

Trough Hole Dimensions

Conveyor Size	"B"	"C"	"D"
0912	9.00	30.125	1.50
1212	12.00	30.125	1.50
1612	16.00	30.125	1.50
1214	12.00	30.125	1.50
1614	16.00	30.125	1.50
2114	21.00	30.125	1.50
1420	14.00	36.125	2.00
1620	16.00	36.125	2.00
2020	20.00	36.125	2.00
2620	26.00	36.125	2.00
3220	32.00	36.125	2.00
2626	26.00	36.125	2.00
3226	32.00	36.125	2.00
3232	32.00	36.125	2.00
3632	36.00	36.125	2.00

### 3. Installation

## Manual Gate Installation

### Manually Operated Gate

1. Install the specified wheel to the shaft by aligning the key and key way, then tighten the set screw. This gate can be operated by a chain, cable or hand wheel. (See Figure 3C.)
2. Manual gates up to 16" wide are fitted with a single rack. Manual gates larger than 16" wide have a double rack.
3. The slide gate plate rides on 1-3/8" double shielded radial bearings for smooth operation.

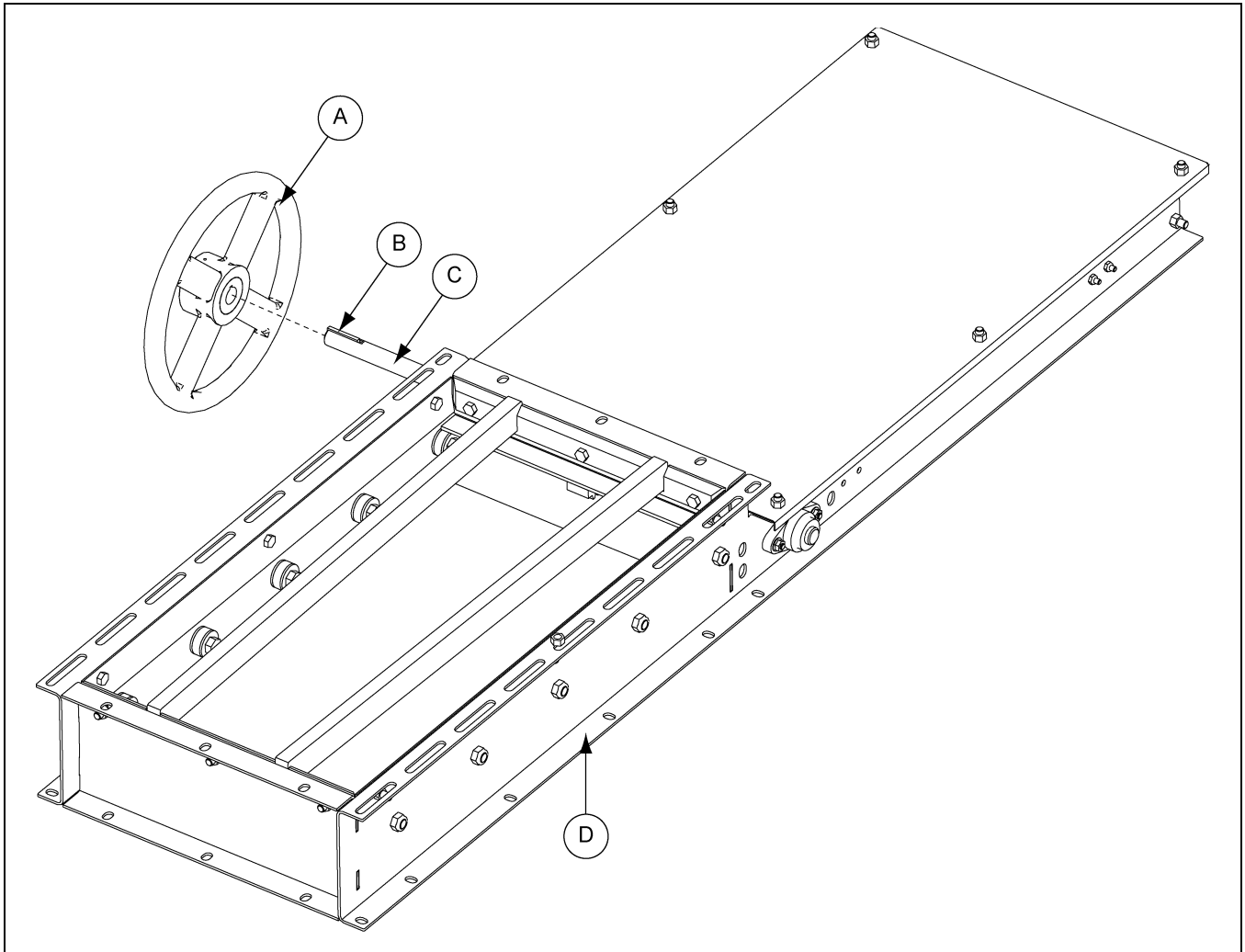

Figure 3C

Ref #	Description
A	Hand Wheel
B	Key
C	Shaft
D	Gate Frame

## Motor Driven Gate Installation

### Install Motor Bracket

1. Install the motor bracket to the gate. Then attach the motor to the bracket as shown in [Figure 3D](#), using the provided hardware.

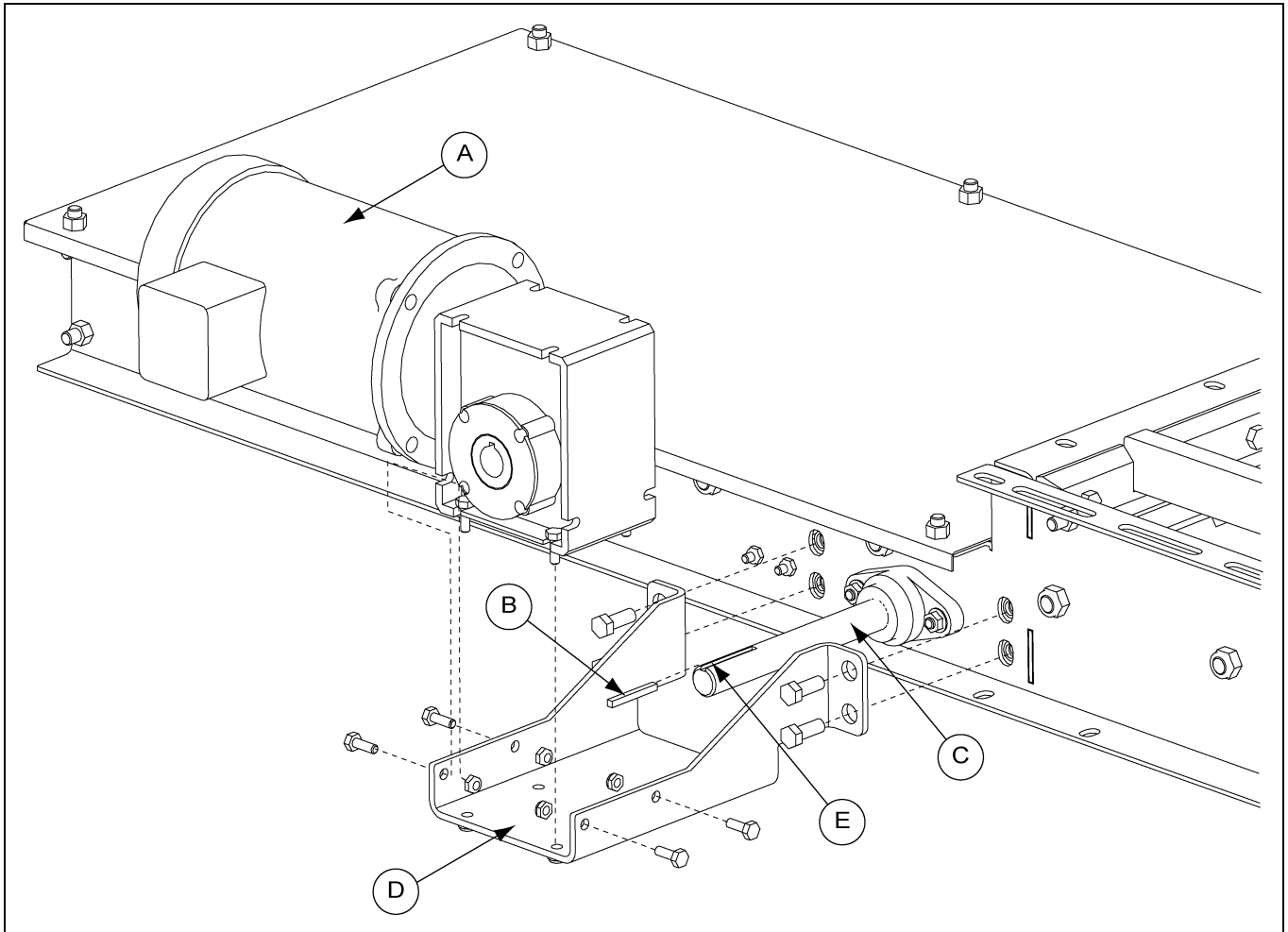

Figure 3D

Ref #	Description
A	Motor
B	Key
C	Shaft
D	Motor Bracket
E	Key Way

### 3. Installation

#### Install Limit Switch

1. Using limit switches that are available in NEMA 4 or explosion proof standards, achieves accurate positioning of these gates. Limit switches are located on both sides of the frame to detect when the gate is completely open or closed.
2. Attach the switch brackets to the inside of the gate as shown using hardware provided. (See [Figure 3E.](#)) Attach limit switch to the bracket as shown in [Figure 3F.](#)
3. After switches are securely fastened, adjust lever arms so they come in contact with tripper blocks on underneath side of slide plate.
4. Disconnect the power at the electrical panel and run the proper gauge electrical wire to the motors and limit switches. (See [Wiring Diagram on Page 16.](#)) **Be sure that the limit switches are adjusted properly before operating the gate.** Turn the power back ON and CAUTIOUSLY operate the gate, opening and closing the gate slide, making the necessary adjustments to the limit switch arms to assure complete opening and closing of the gate.
5. Motor driven gates are available in both TEFC and explosion proof configurations.

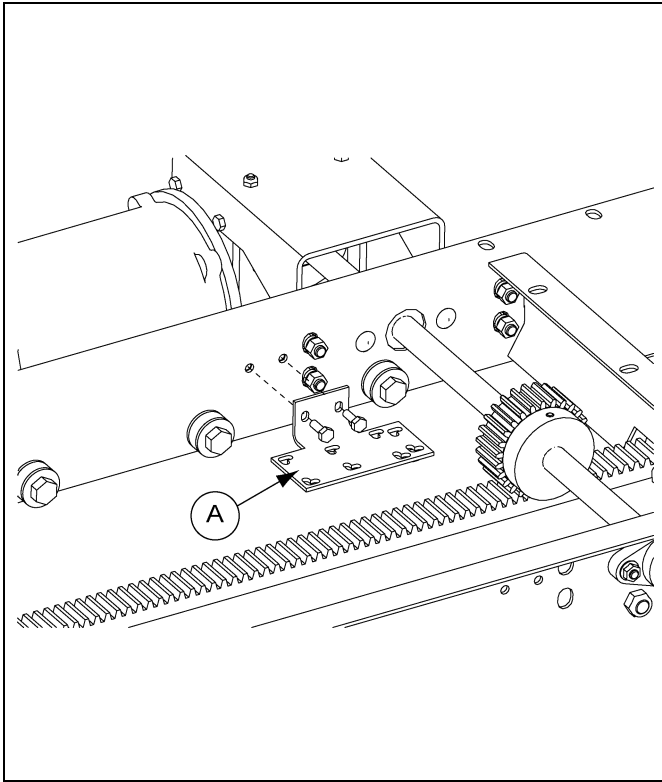

Figure 3E

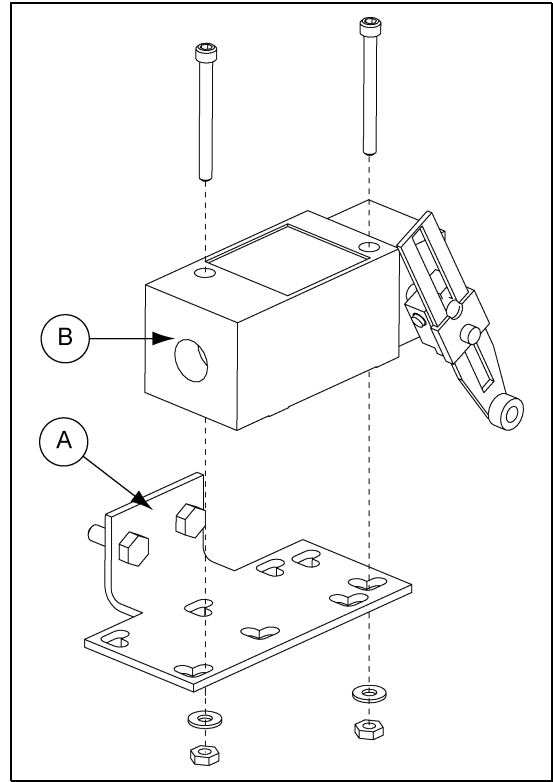

Figure 3F

Ref #	Description
A	Switch Bracket
B	Limit Switch

Install Limit Switch (Continued)

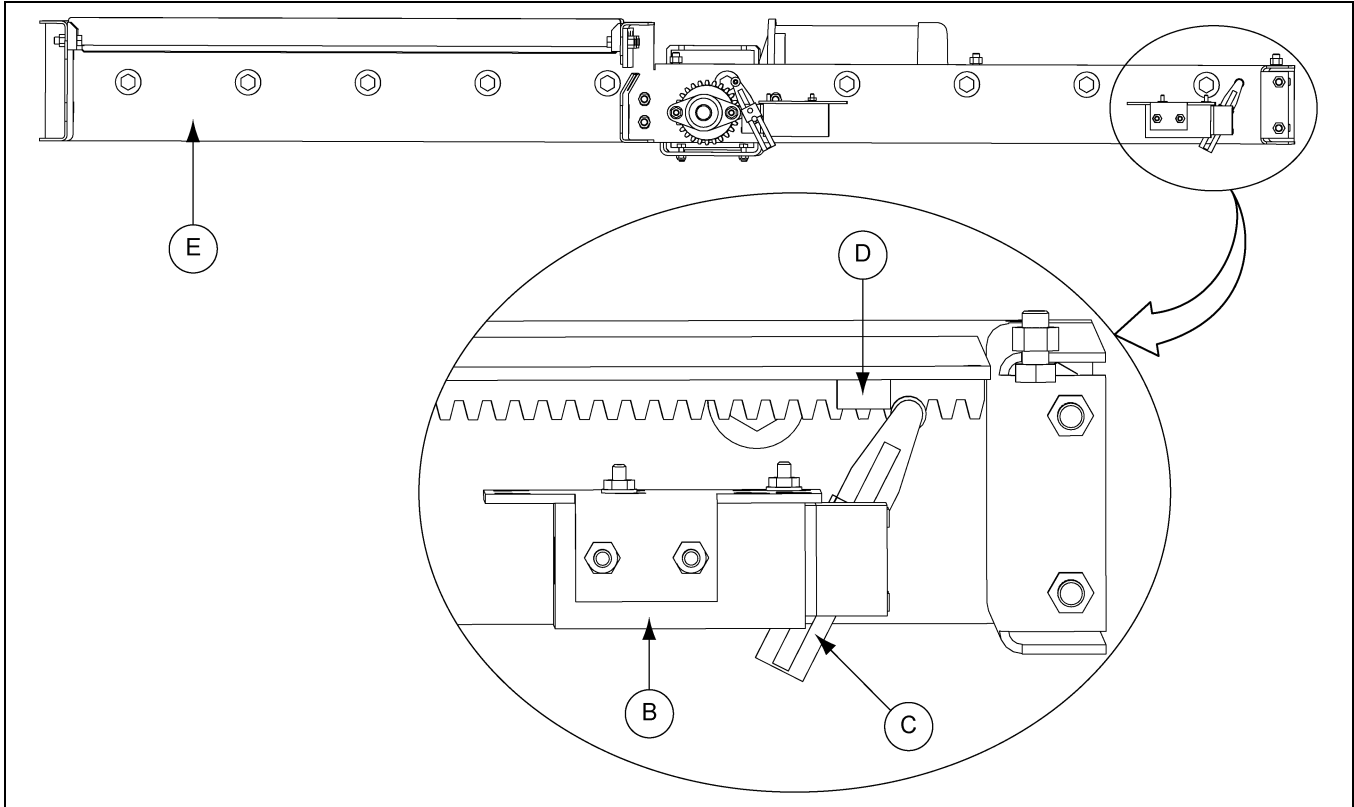

Figure 3G

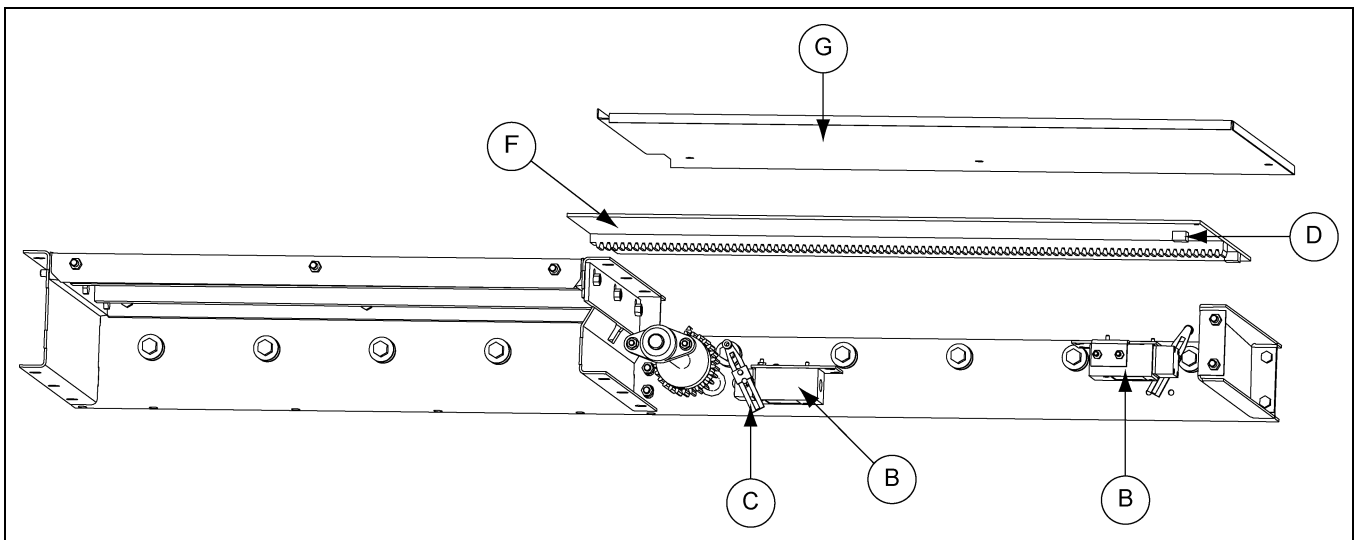

Figure 3H EXPLODED VIEW shown without side for clarity.

Ref #	Description
B	Limit Switch
C	Actuator Arm
D	Tripper Block

Ref #	Description
E	Side view with side removed clarity.
F	Slide Gate
G	Cover

### 3. Installation

#### Install Limit Switch (Continued)

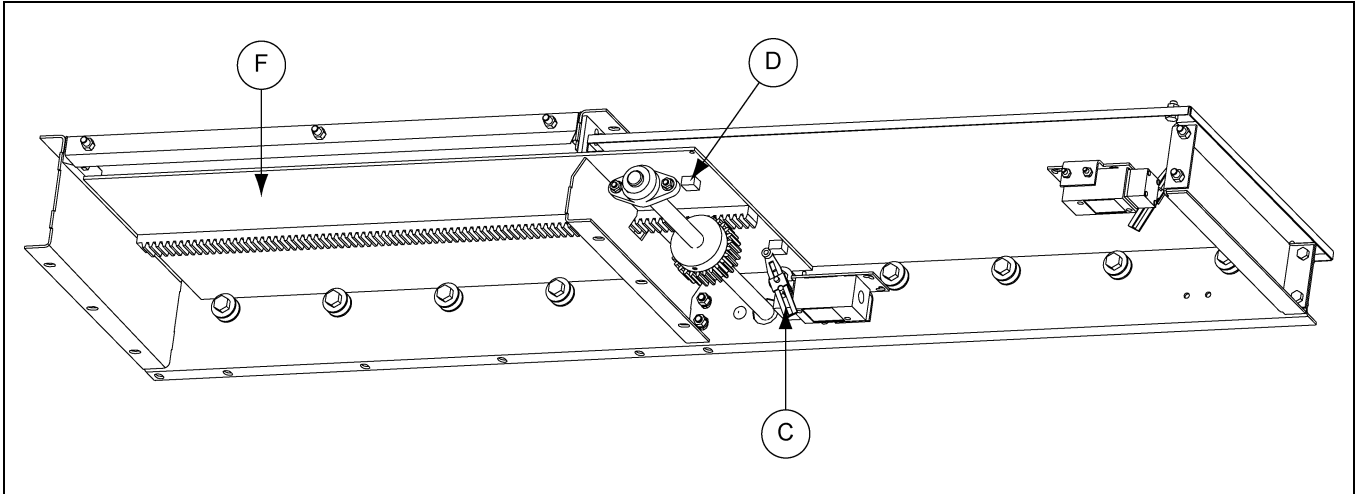

Figure 3I **GATE CLOSED POSITION** shown without side for clarity.

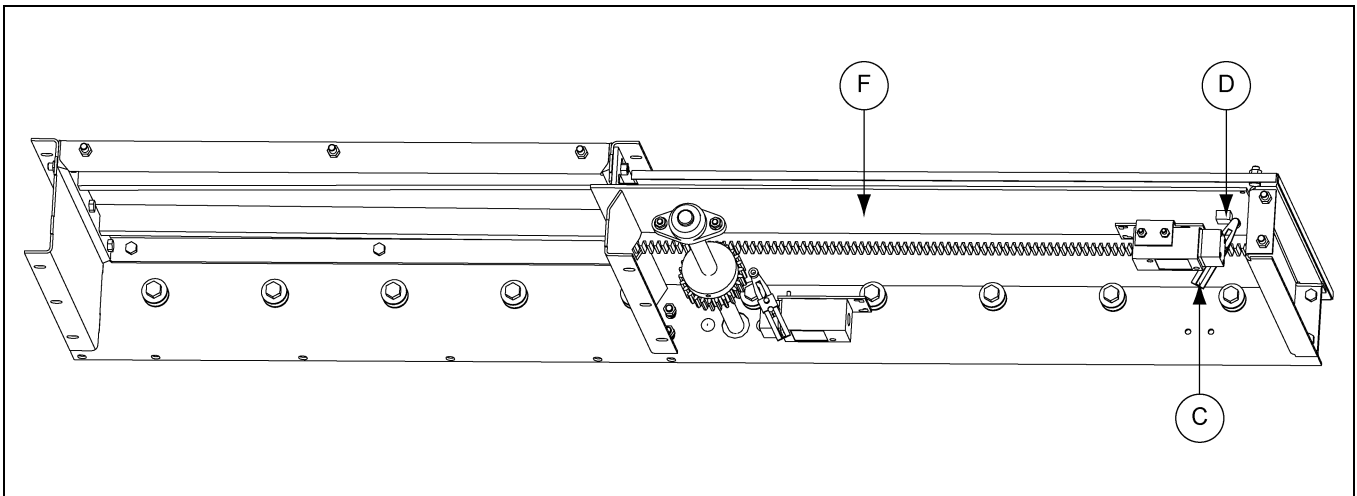

Figure 3J **GATE OPENED POSITION** shown without side for clarity.

Ref #	Description
C	Actuator Arm
D	Tripper Block
F	Slide Gate

## Install Gate Frame to Trough

1. Determine the existing hardware that must be removed to install the gate. Remove the hardware and retain for re-installation.
2. Gates have slotted mounting flanges. Use the existing intermediate bottom holes and gate slots for mounting. If no existing holes are available then new 7/16" holes will need to be drilled. The easiest method is to match drill the gate flange to existing intermediate bottom holes or alternatively match drill the intermediate bottom flanges to existing gate flange slots. Regardless of either method, a maximum of 8" bolt spacing should be kept.
3. Install the gate to the intermediate using the removed hardware. The gate should be mounted so the gate slide closes toward the conveyors head (discharge) section.
4. Adjust the carry-over bar frame so that the top of the carry-over bars are flush to the inside surface of the intermediate bottom.

**NOTE:** Failure to properly adjust the carry-over bar frame will cause severe damage to the chain and/or gate.

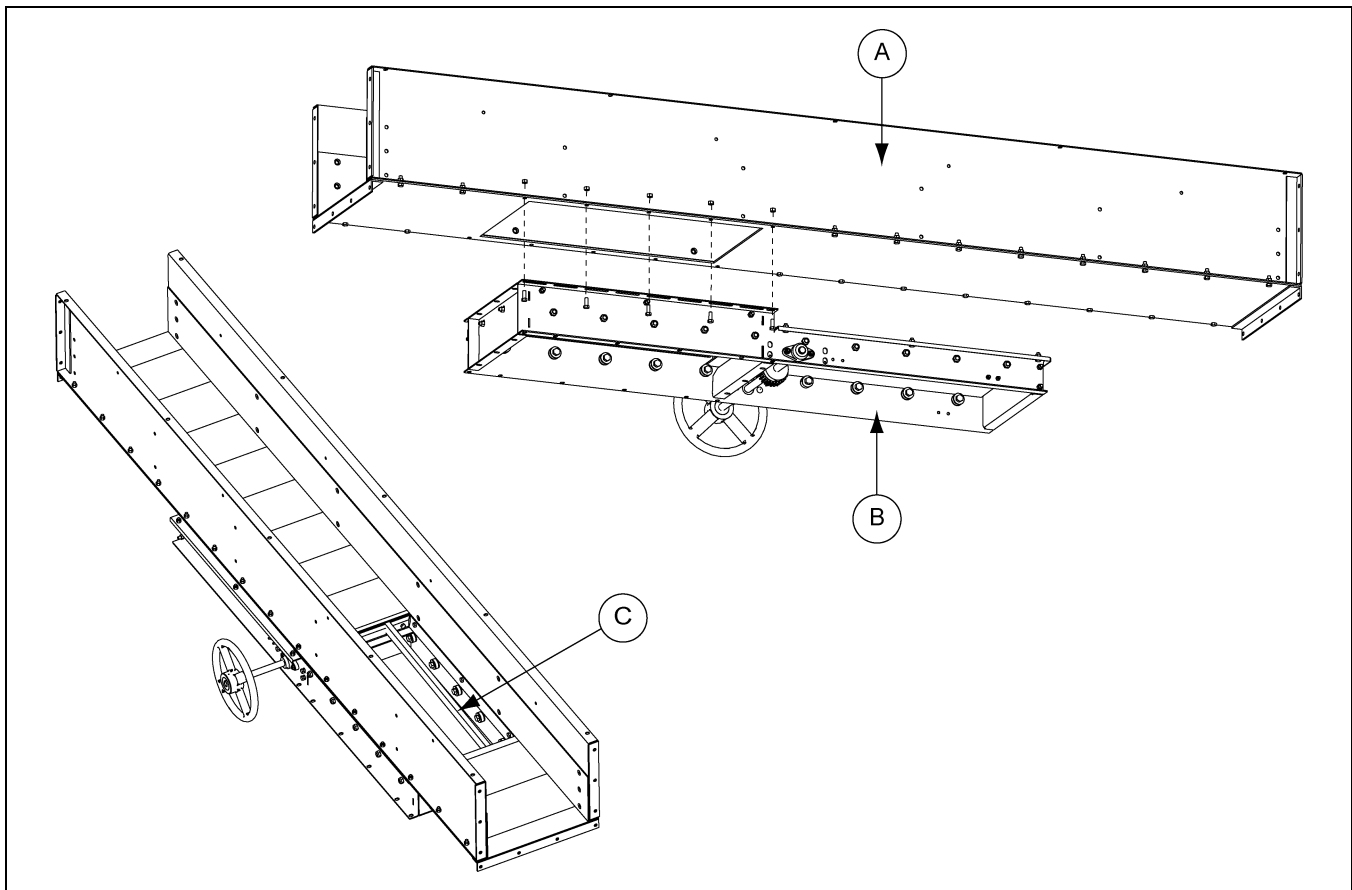
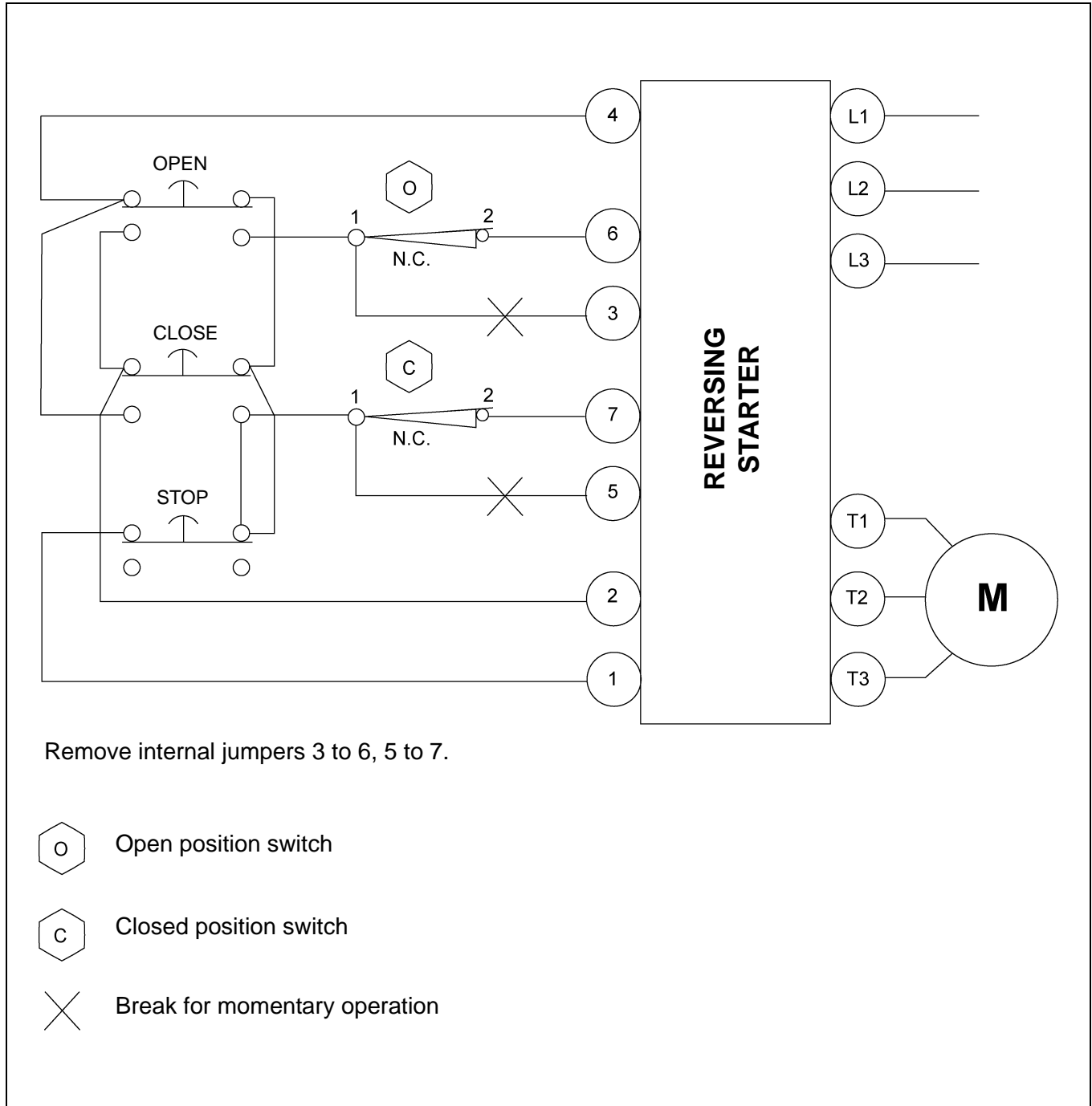

Figure 3K

Ref #	Description
A	Trough Section
B	Gate Assembly
C	Carry-Over Bars

## 4. Wiring Diagram

### Typical Wiring Diagram





## Limited Warranty — N.A. Grain Products

The GSI Group, LLC. ("GSI") warrants products which it manufactures, to be free of defects in materials and workmanship under normal usage and conditions for a period of 12 months from the date of shipment (or, if shipped by vessel, 14 months from the date of arrival at the port of discharge). If, in GSI's sole judgment, a product is found to have a defect in materials and/or workmanship, GSI will, at its own option and expense, repair or replace the product or refund the purchase price. This Limited Warranty is subject to extension and other terms as set forth below.

**Warranty Enhancements:** The warranty period for the following products is enhanced as shown below and is in lieu of (and not in addition to) the above stated warranty period. (Warranty Period is from date of shipment.)

	Product	Warranty Period
<b>Storage</b>	Grain Bin Structural Design • Sidewall, roof, doors, platforms and walkarounds • Flooring (when installed using GSI specified floor support system for that floor) • Hopper tanks (BFT, GHT, NCHT, and FCHT)	5 Years
<b>Conditioning</b>	Dryer Structural Design – (Tower, Portable and TopDry) • Includes (frame, portable dryer screens, ladders, access doors and platforms)	5 Years
	All other Dryer parts including: • Electrical (controls, sensors, switches and internal wiring)	2 Years
	All Non-PTO Driven Centrifugal and Axial Fans	3 Years
	Bullseye Controllers	2 Years
<b>Material Handling</b>	Bucket Elevators Structural Design	5 Years
	Towers Structural Design	5 Years
	Catwalks Structural Design	5 Years
	Accessories (stairs, ladders and platforms) Structural Design	5 Years

### Conditions and Limitations:

THERE ARE NO WARRANTIES THAT EXTEND BEYOND THE LIMITED WARRANTY DESCRIPTION SET FORTH HEREIN; SPECIFICALLY, GSI DISCLAIMS ANY AND ALL OTHER WARRANTIES OF ANY KIND, EXPRESS OR IMPLIED, INCLUDING, WITHOUT LIMITATION, WARRANTIES OF MERCHANTABILITY OR FITNESS FOR A PARTICULAR PURPOSE OR USE IN CONNECTION WITH: (I) ANY PRODUCT MANUFACTURED OR SOLD BY GSI, OR (II) ANY ADVICE, INSTRUCTION, RECOMMENDATION OR SUGGESTION PROVIDED BY AN AGENT, REPRESENTATIVE OR EMPLOYEE OF GSI REGARDING OR RELATED TO THE CONFIGURATION, INSTALLATION, LAYOUT, SUITABILITY FOR A PARTICULAR PURPOSE, OR DESIGN OF SUCH PRODUCTS.

The sole and exclusive remedy for any claimant is set forth in this Limited Warranty and shall not exceed the amount paid for the product purchased. This Warranty only covers the value of the warranted parts and equipment, and does not cover labor charges for removing or installing defective parts, shipping charges with respect to such parts, any applicable sales or other taxes, or any other charges or expenses not specified in this Warranty. GSI shall not be liable for any other direct, indirect, incidental or consequential damages, including, without limitation, loss of anticipated profits or benefits. Expenses incurred by or on behalf of a claimant without prior written authorization from the GSI warranty department shall not be reimbursed. This warranty is not transferable and applies only to the original end-user. GSI shall have no obligation or responsibility for any representations or warranties made by or on behalf of any dealer, agent or distributor. Prior to installation, the end-user bears all responsibility to comply with federal, state and local codes which apply to the location and installation of the products.

This Limited Warranty extends solely to products sold by GSI and does not cover any parts, components or materials used in conjunction with the product, that are not sold by GSI. GSI assumes no responsibility for claims resulting from construction defects, unauthorized modifications, corrosion or other cosmetic issues caused by storage, application or environmental conditions. Modifications to products not specifically delineated in the manual accompanying the product at initial sale will void all warranties. This Limited Warranty shall not extend to products or parts which have been damaged by negligent use, misuse, alteration, accident or which have been improperly/inadequately maintained.

#### Notice Procedure:

In order to make a valid warranty claim a written notice of the claim must be submitted, using the RMA form, within 60 days of discovery of a warrantable nonconformance. The RMA form is found on the OneGSI portal.

#### Service Parts:

GSI warrants, subject to all other conditions described in this Warranty, Service Parts which it manufactures for a period of 12 months from the date of purchase unless specified in Enhancements above.

This equipment shall be installed in accordance with the current installation codes and applicable regulations, which should be carefully followed in all cases. Authorities having jurisdiction should be consulted before installations are made.

**G S I G R O U P**



**GSI Group**  
**1004 E. Illinois St.**  
**Assumption, IL 62510-0020**  
**Phone: 1-217-226-4421**  
**Fax: 1-217-226-4420**  
**[www.gsiag.com](http://www.gsiag.com)**



**GSI is a worldwide brand of AGCO Corporation.**