

Scattergrain Grain Spreader

Model: FFD-120-WH

Installation and Operation Manual



PNEG-258

Version: 2.0

Date: 02-22-18



PNEG-258

All information, illustrations, photos and specifications in this manual are based on the latest information available at the time of publication. The right is reserved to make changes at any time without notice.

Contents

Chapter 1 Safety	4
Safety Guidelines	4
Cautionary Symbols Definitions	5
Safety Cautions	6
Safety Sign-Off Sheet	8
Chapter 2 Decals	9
Chapter 3 Grain Spreader Assembly Instructions	11
Chapter 4 Installation	12
Grain Spreader Installation	12
Chapter 5 Instructions	14
Operating Instructions	14
Adjustment for Bin Fill	15
Chapter 6 Maintenance	16
Chapter 7 Troubleshooting Guide	17
Correct Spreading Pattern	17
Chapter 8 Power Spreader Parts Assembly	18
Scattergrain Spreader 1/2 HP Parts (FFD-120-WH)	18
Chapter 9 Warranty	21

Safety Guidelines

Safety guidelines are general-to-specific safety rules that must be followed at all times. This manual is written to help you understand safe operating procedures and problems that can be encountered by the operator and other personnel when using this equipment. Save these safety guidelines for future reference.

As owner or operator, you are responsible for understanding the requirements, hazards, and precautions that exist and to inform others as required. Unqualified persons must stay out of the work area at all times.

Alterations must not be made to the equipment. Alterations can produce dangerous situations resulting in **SERIOUS INJURY** or **DEATH**.

This equipment must be installed in accordance with the current installation codes and applicable regulations, which must be carefully followed in all cases. Authorities having jurisdiction must be consulted before installations are made.

When necessary, you must consider the installation location relative to electrical, fuel and water utilities.

Personnel operating or working around equipment must read this manual. This manual must be delivered with equipment to its owner. Failure to read this manual and its safety instructions is a misuse of the equipment.

ST-0001-3

Cautionary Symbols Definitions

Cautionary symbols appear in this manual and on product decals. The symbols alert the user of potential safety hazards, prohibited activities and mandatory actions. To help you recognize this information, we use the symbols that are defined below.



This symbol indicates an imminently hazardous situation which, if not avoided, **will result in serious injury or death.**



This symbol indicates a potentially hazardous situation which, if not avoided, **can result in serious injury or death.**



This symbol indicates a potentially hazardous situation which, if not avoided, **can result in minor or moderate injury.**



This symbol is used to address practices not related to personal injury.



This symbol indicates a general hazard.



This symbol indicates a prohibited activity.

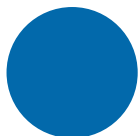

This symbol indicates a mandatory action.

ST-0005-2

Safety Cautions

Use Personal Protective Equipment

- Use appropriate personal protective equipment:

Eye Protection



Respiratory Protection



Foot Protection



Hearing Protection



Head Protection



Fall Protection



Hand Protection



- Wear clothing appropriate to the job.
- Remove all jewelry.
- Tie long hair up and back.

ST-0004-1

Follow Safety Instructions

- Carefully read all safety messages in this manual and safety signs on your machine. Keep signs in good condition. Replace missing or damaged safety signs. Be sure new equipment components and repair parts include the current safety signs. Replacement safety signs are available from the manufacturer.
- Learn how to operate the machine and how to use controls properly. Do not let anyone operate without instruction.
- If you do not understand any part of this manual or need assistance, contact your dealer.



ST-0002-1

Maintain Equipment and Work Area

- Understand service procedures before doing work. Keep area clean and dry.
- Never service equipment while it is operating. Keep hands, feet, and clothing away from moving parts.
- Keep your equipment in proper working condition. Replace worn or broken parts immediately.



ST-0003-1

Sharp Edge Hazard

- This product has sharp edges, which can cause serious injury.
- To avoid injury, handle sharp edges with caution and always use proper protective clothing and equipment.



ST-0036-2

Operate Motor Properly

- All electrical connections must be made in accordance with applicable local codes (National Electrical Code for the US, Canadian Electric Code, or EN60204 along with applicable European Directives for Europe). Make sure equipment and bins are properly grounded.
- Lock-out power before resetting motor overloads.
- Do not repetitively stop and start the drive in order to free a plugged condition. Jogging the drive in this manner can damage the equipment and drive components.



ST-0009-3

Lifting Hazard

- Single person lift can cause injury.
- Use a mechanical lifting device to lift or move the equipment during installation.





ST-0021-2

The safety decals on your equipment are safety indicators which must be carefully read and understood by all personnel involved in the installation, operation, service and maintenance of the equipment.

To replace a damaged or missing decal, contact us to receive a free replacement.

GSI Decals

1004 E. Illinois St.
Assumption, IL. 62510
Phone: 1-217-226-4421

Location	Decal #	Decals	Description
Bin	DC-1224	 <p>DANGER</p> <p>High voltage. Will cause serious injury or death. Lockout power before servicing.</p> <p><small>DC-1224</small></p>	Decal, High Voltage
Bin	DC-1225	 <p>WARNING</p> <p>Stay clear of rotating blade. Blade could start automatically. Can cause serious injury. Disconnect power before servicing.</p> <p><small>GSI Group 217-226-4421 DC-1225</small></p>	Decal, Warning Rotating Blade
Inside Bin Door Cover of the 2 ring Door, 24" Porthole Door Cover and Roof Manway Cover	DC-GBC-1A	 <p>DANGER</p> <p>Rotating fighting will kill or dismember. Flowing material will trap and suffocate. Crusted material will collapse and suffocate.</p> <p>Keep clear of all augers. DO NOT ENTER this bin!</p> <p>If you must enter the bin: 1. Shut off and lock out all power. 2. Use a safety harness and safety line. 3. Station another person outside the bin. 4. Avoid the center of the bin. 5. Wear proper breathing equipment or respirator.</p> <p>Failure to heed these warnings will result in serious injury or death.</p> <p><small>DC-GBC-1A</small></p>	Danger Keep Clear of Augers

2. Decals

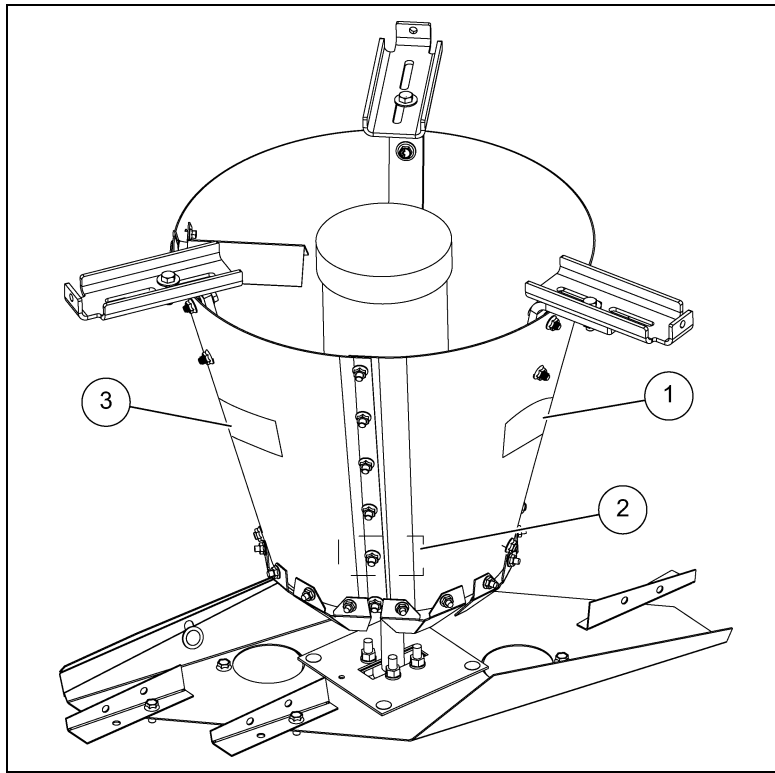

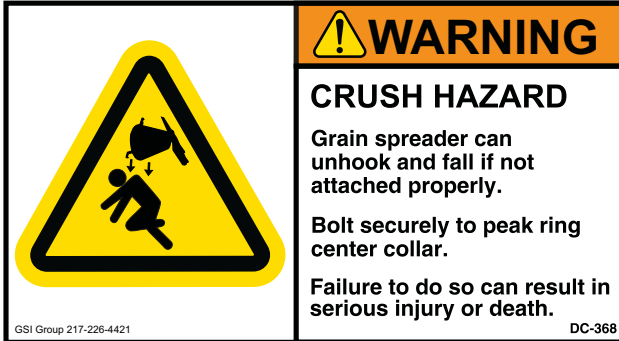



Figure 2A

Ref #	Location	Decal #	Decals	Description
1	Cone Segment	DC-1639	 <p>DC-1639</p>	Decal, Logo Scattergrain
2	Cone Segment	DC-368	 <p>GSI Group 217-226-4421</p> <p>! WARNING CRUSH HAZARD Grain spreader can unhook and fall if not attached properly. Bolt securely to peak ring center collar. Failure to do so can result in serious injury or death.</p> <p>DC-368</p>	Decal, Warning for Spreader
3	Cone Segment	DC-1612	 <p>GSI Group 217-226-4421</p> <p>! DANGER High voltage. Will cause injury or death. Lockout power before servicing.</p> <p>! WARNING Stay clear of rotating blade. Blade could start automatically. Can cause serious injury. Disconnect power before servicing.</p> <p>DC-1612</p>	Decal, Danger DC-1225/DC-1611

3. Grain Spreader Assembly Instructions

1. Carefully unpack the unit and inspect for shipping damage.
2. Check tightness of all bolts in the cone and blade assemblies.
3. Select the proper number of diverter segments required. (See diverter segments chart [below](#).)

Diverter Segments Chart

Fill Auger (Diameter)	Diverter Segments (# Required)
6"	8
8"	4 (Equally Spaced)
10" or Larger	0

NOTE: *The various types of grain, moisture content, bin diameter and capacity of fill auger are all conditions that impact the evenness of spread. Some experimentation is needed to attain the ideal spread pattern.*

4. Installation

Grain Spreader Installation

1. Adjust hanger extensions to fit roof opening and install the power spread unit.
2. Use the 9/32" hole at the end of each hanger extension and bolt hanger extensions to hatch collar.
3. Tighten all bolts holding hanger extensions.
4. Once unit is installed, use a carpenter's level (1) across the top of the spreader cone to confirm it is level in all directions. (See Figure 4A.)

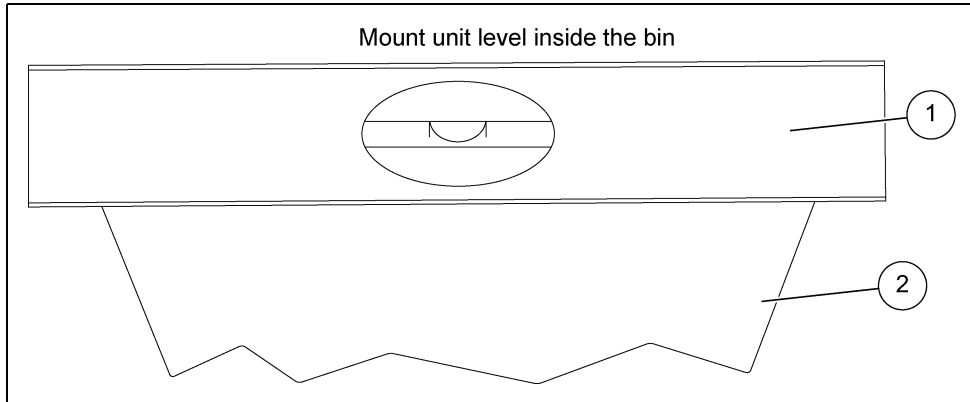

Figure 4A Mount Spreader and Check with Level

Ref #	Description
1	Carpenter's Level
2	Grain Spreader

5. If the unit is not level, add spacer washers between hanger brackets and hanger extensions to level unit. (See Figure 4B.)

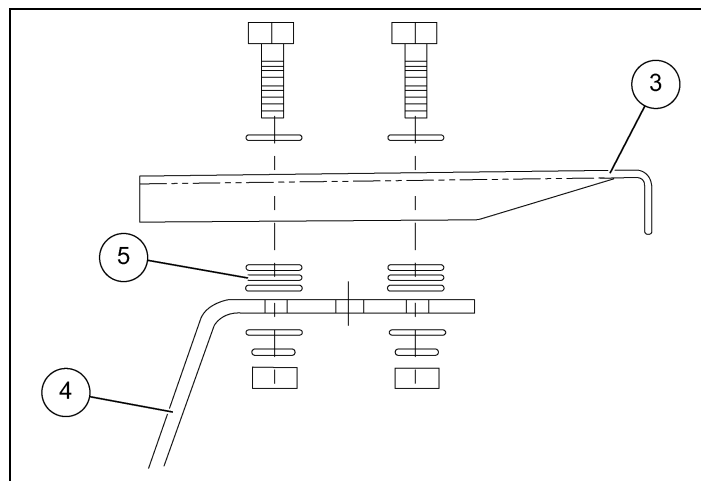

Figure 4B Use Washers to Level Unit

Ref #	Part #	Description
3	SPD-2008	Hanger Extension
4	SPD-2010	Hanger Extension
5		Use Washer to Level Unit (If required)

Grain Spreader Installation (Continued)



The Scattergrain 1/2 HP motor is protected with an internal automatic reset overload. Before servicing, all power to the unit must be disconnected and locked out to avoid a possible re-set/re-start and serious injury.

Before connecting and applying power, rotate the spreader blade by hand to be certain it rotates freely without obstruction. The motor turns the spreader blade counterclockwise as viewed from above the unit. The power spread unit requires 115 volt power supply. The minimum wire size is 14 gauge for runs up to 200'. It is advisable to provide additional protection such as 15 amp slow blow fuses or 20 amp circuit breaker. Consult a licensed electrician for wire size on longer runs. Regardless of grain type and bin size, the grain flow must be directly down (vertical) and centered (horizontal) within the spreader cone. (See Figure 4C.) This must be done in order to prevent high and low grain surface areas from one side of the bin to the other.

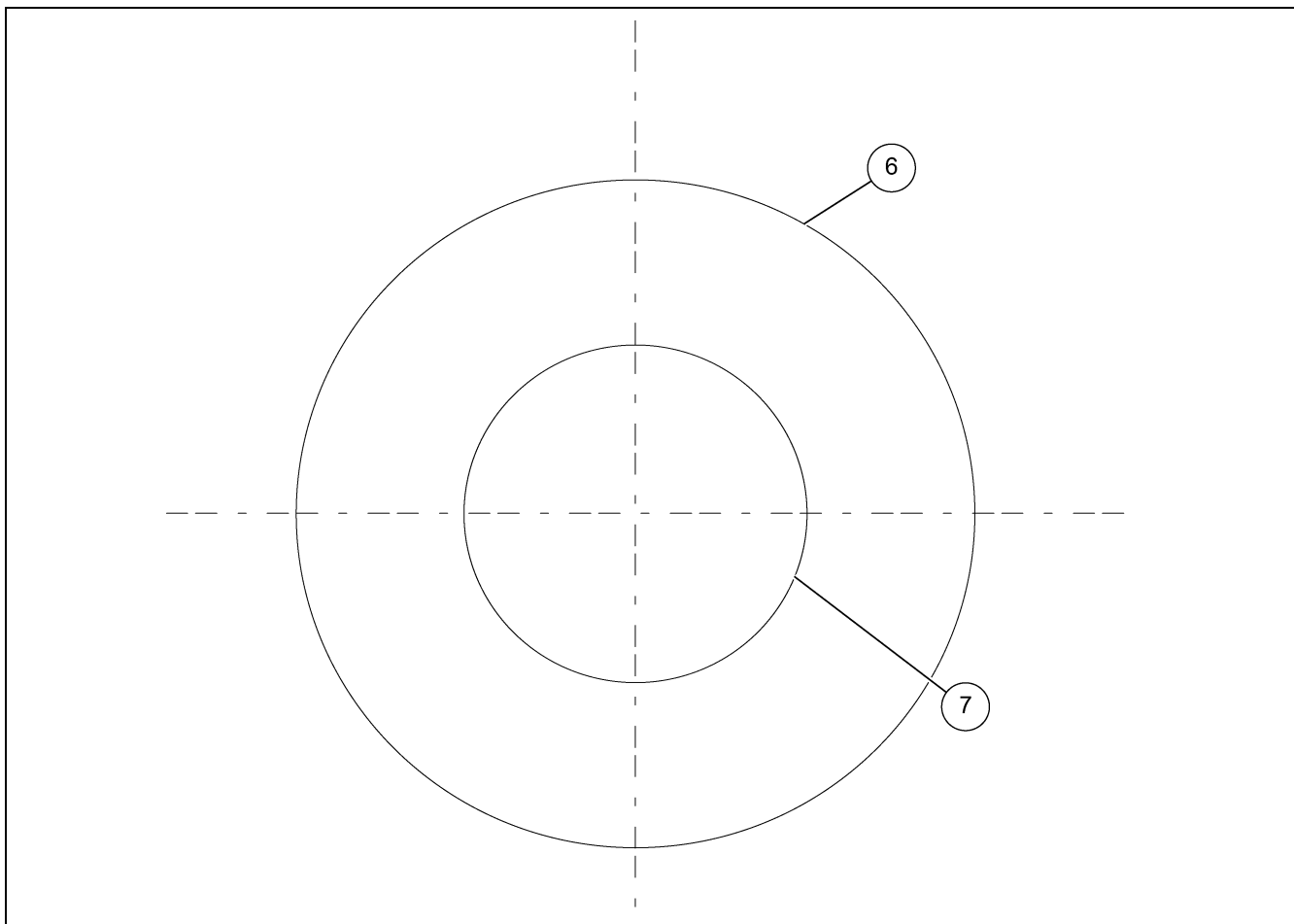

Figure 4C Grain Flow Must be Centered Within the Spreader Cone

Ref #	Part #	Description
6	SPD-2007	Spreader cone
7		Grain flow

5. Instructions

Operating Instructions

The grain spreader blade assembly has four features to adjust the grain flow pattern.

1. Tilt adjusts the entire spreader blade, which controls overall grain spread. To adjust tilt, loosen the two U-bolts that allow the blade to tip up and down. This may vary according to bin diameter and fill rate. (See Figure 5A.)

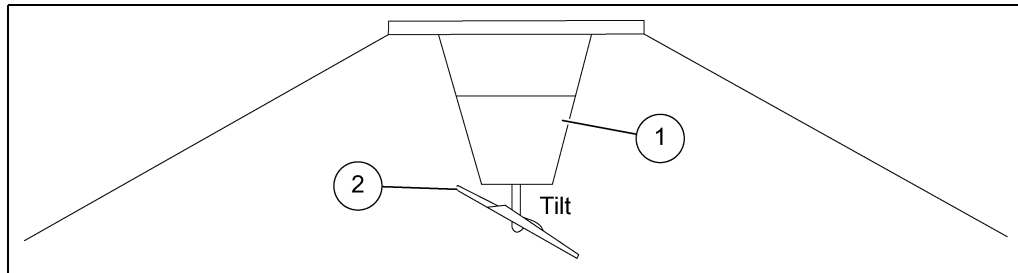

Figure 5A Adjustment of the Tilt

Ref #	Description
1	Grain Spreader
2	Single spreader diverter end up for desired grain spread.

2. Spreader diverters (grain guide baffles) are used to increase or decrease grain flow resistance over the spreader blade. With the diverters straight, the grain will travel farther. Angled grain diverters shorten the throwing distance. (See Figure 5B.)

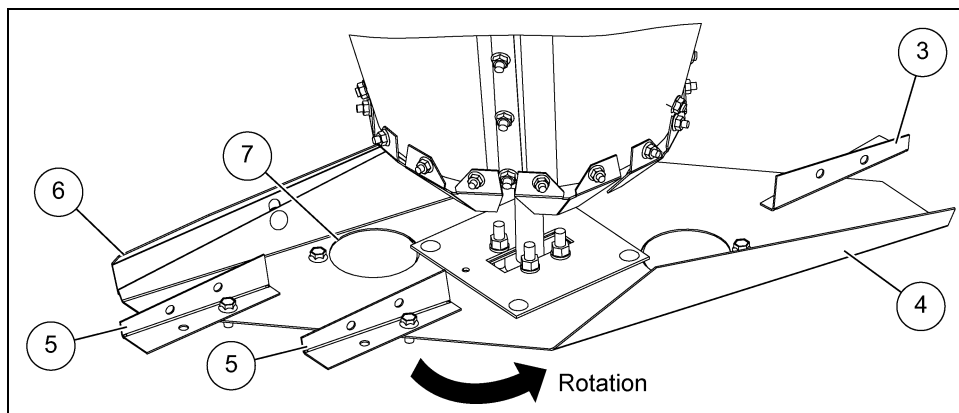

Figure 5B Four Features for Adjusting the Grain Flow Pattern

Ref #	Description
3	Upper Guide Baffle
4	Tilt can be adjusted to suit different bin diameters. Decrease tilt for longer throw with large diameter bins.
5	Lower Grain Guide Baffles - Adjust guides in line with grain stream for maximum throw in large diameter bins or across stream to deflect flow for smaller diameter bins.

Ref #	Description
6	Adjustable Blade Extension
7	Damper Plates - Open to increase filling at center of bin or close to decrease.

3. Blade extension is used when extra throwing distance is required for larger bins.
4. Dampers are used to control center filling.

Adjustment for Bin Fill

Ref #	Part	Type	Large Bin 36" Diameter and Greater	Small Bin 24" Diameter and Less
			Operation/Procedure	Operation/Procedure
1	Spreader Blade	Tilt	Decrease (flatten)/loosen U-bolts and pivot the blade to horizontal. Always refer to single diverter side as gauge.	Increase/loosen U-bolts and pivot the blade (single diverter side) upward.
2	Spreader Diverter	Single Side	Decrease (center filling)/loosen bolts and rotate diverter clockwise.	Increase (center filling)/loosen bolt and rotate diverter counterclockwise.
		Dual Side	Decrease (center filling)/loosen bolts and rotate diverters clockwise to direct flow in line with grain stream.	Increase (center filling)/loosen bolt and rotate diverters counterclockwise to direct flow across grain stream.
3	Blade Extension	Tilt	Increase/loosen bolt and pivot the extension upward to maximum allowance in slotted hole.	Remove blade extension.
4	Damper	Opening	Decrease (center filling)/loosen bolts and pivot dampers to nearly closed position.	Increase (center filling)/loosen bolts and pivot dampers to almost fully open position.

1. Rotation is always viewed from top of the unit looking down on to the blade.
2. Be sure to fully tighten all bolts after each adjustment is made.
3. These adjustments describe the requirements for both extremes of bin sizes. For bin sizes between 24" and 36" in diameter, start with intermediate adjustments and vary slightly as required to reach desired results.

6. Maintenance

For normal operation, annually re-lubricate both motor bearings with approximately ten drops of 5W-30 oil. The gears of the gearbox assembly are lubricated with a special high temperature, food grade lubricant (SPD-2109) at the time of manufacturing. The level of grease in the gearbox should be checked annually and will not normally require further lubrication unless seal breakage occurs. After the grease has settled to the bottom of the gearbox, the grease level can be checked. The grease level should not be more than 1/4" below the vent plug. (See Figure 6A.) It may be necessary to insert a wire through vent plug hole to determine the grease level. The grease level also can be checked by removing motor and viewing grease level through the hole for the motor pinion gear.

Inspect seals annually for signs of leakage (check bearings annually for tightness).

In the event the motor fails to start, check power supply to the motor. If power supply exists and motor still fails to start, disconnect power and check blade for freedom of rotation. If power does not exist, check for blown fuse or flipped circuit breaker.

If motor stops operating for no apparent reason, wait approximately 5 minutes for the automatic overload protection device to reset and reattempt operation. If problem continues, check power supply for voltage and check blade of unit for freedom of rotation.

If motor pinion requires removal for any reason, it must be properly installed and located, as shown in the parts assembly on Page 18.

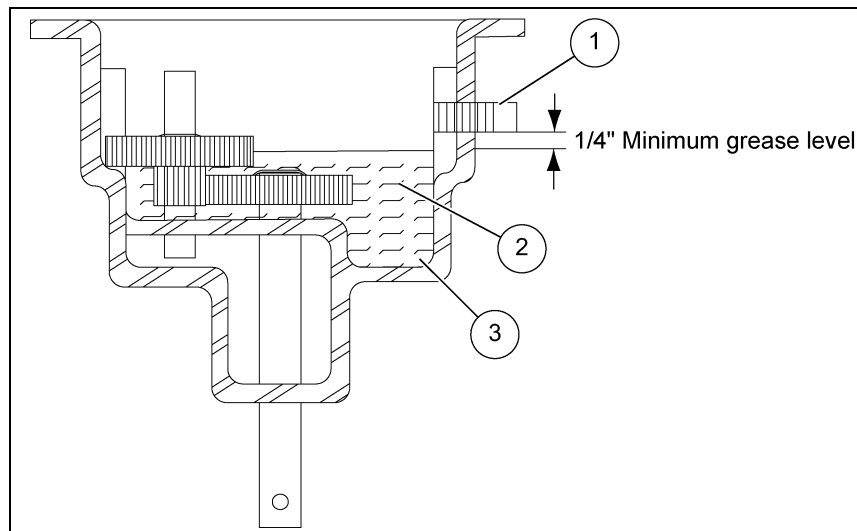

Figure 6A The Gear Box Assembly Showing Grease Level

Ref #	Part #	Description
1		Vent Plug
2	SPD-2109	Special Lubricant
3	308-1007-1	Spreader Gearbox Assembly Toledo Gearbox



Disconnect power supply before attempting any type of service. The motor is protected with a self-resetting overload protection.



Failure to disconnect power can result in serious injury or death.

Correct Spreading Pattern

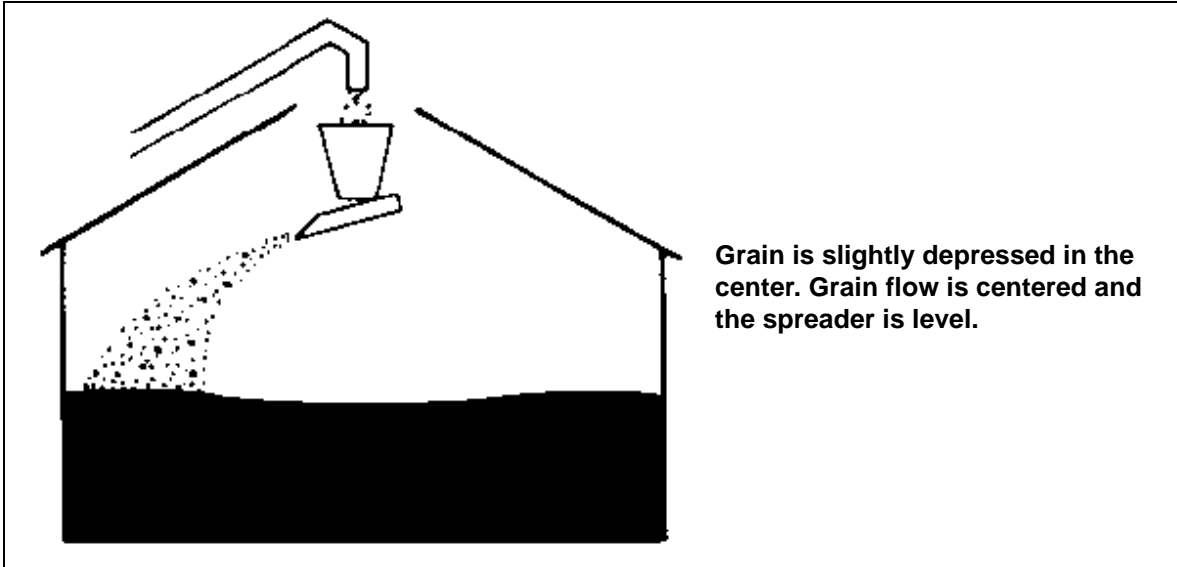

Trouble	Probable Cause	Illustration
Large doughnut shaped ring caused by grain hitting high on bin wall.	Tilt blade downward, decrease bite. Remove blade extension.	<p>Spreader blade too flat</p>
Grain is high in center of bin, small dough nut.	Flatten blade, increase bite, decrease grain flow to spreader. Add blade extension.	<p>Spreader blade too steep</p>
Grain is high on one side of bin.	Level spreader, correct grain flow to spreader, (never allow grain to flow into spreader at an angle or off center).	<p>Not level, not centered</p>

8. Power Spreader Parts Assembly

Scattergrain Spreader 1/2 HP Parts (FFD-120-WH)

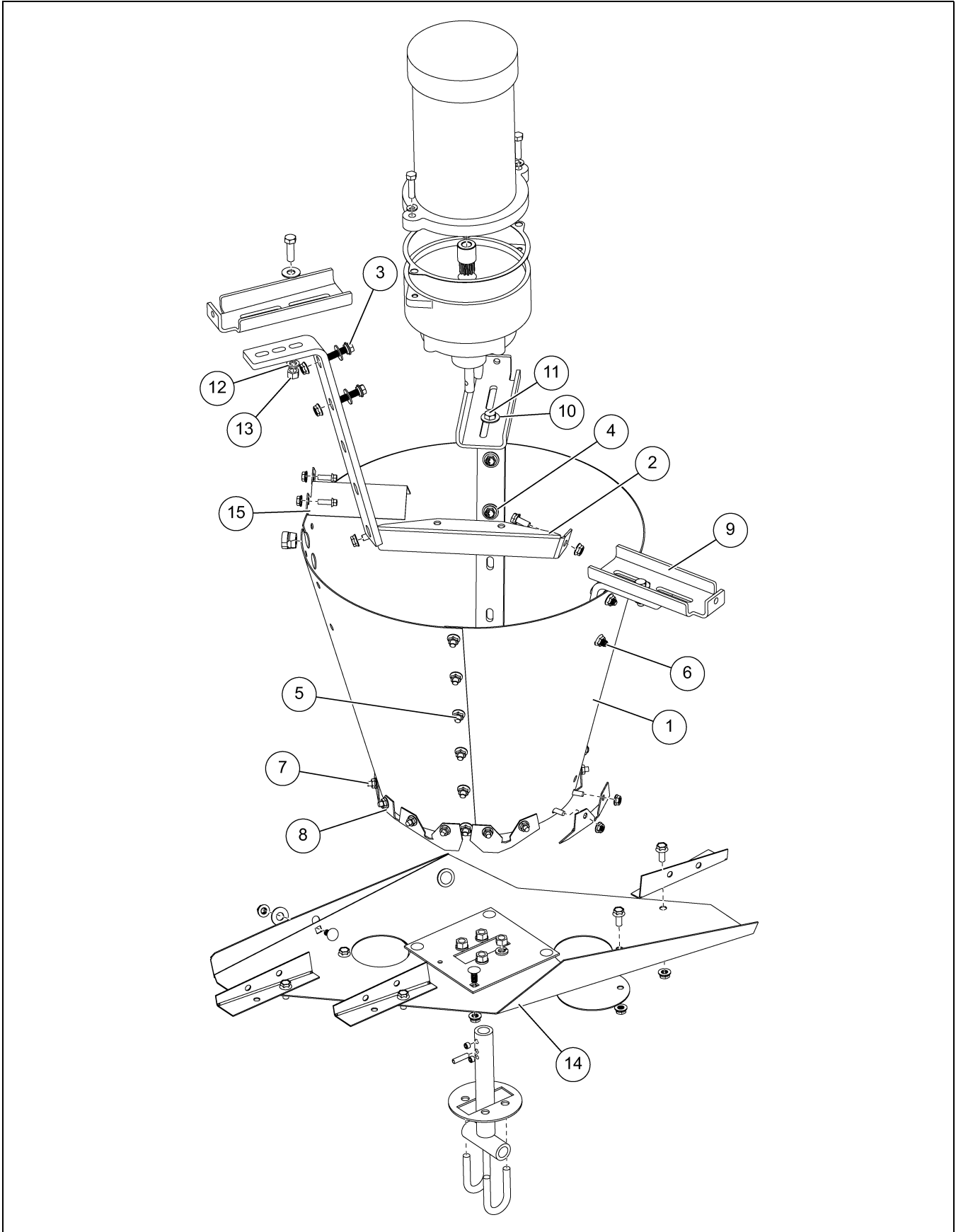

8. Power Spreader Parts Assembly

Scattergrain Spreader 1/2 HP (FFD-120-WH) Parts List

Ref #	Part #	Description	Qty
1	401-1032-2	Cone Segment	1
2	306-1169-3	Gearbox Mounting Bracket	2
3	S-7483	Flange Bolt 5/16"-18 x 1-1/4" JS500 Grade 8 or Grade 8.2 Full Threaded with Sealing Washer	6
4	S-845	Flat Washer 5/16" USS SAE YDP Grade 2	6
5	S-6606	Flange Bolt 5/16"-18 x 3/4" ZN Grade 5	14
6	S-3611	Flange Nut 5/16"-18 YDP Grade 2	16
7	S-8680	Flange Bolt 1/4"-20 x 3/4" ZN Grade 5	18
8	S-7215	Flange Nut 1/4"-20 ZN	18
9	SPD-2008	Hanger Extension	3
10	S-248	Flat Washer 3/8" 7/16" I.D. 1" O.D. YDP	3
11	S-2071	Bolt, HHCS 3/8"-16 x 1-1/4" ZN Grade 5	3
12	S-1054	Split Lock Washer 3/8" ZN	3
13	S-456	Hex Nut 3/8"-16 YDP Grade 5	3
14	SPD-2138	1/2" HP Blade Assembly	1
15	SPD-2176	Cord Shield FFD-120 Scattergrain	1
N/S	415-2408-2C	Motor/Gear Box Assembly 120WH 1/2"	1
N/S	DC-1612	Decal, Danger DC-1225/DC-1611	1
N/S	DC-1639	Decal, Logo Scattergrain	1
N/S	DC-368	Decal, Warning for Spreader	1
N/S	SPD-2149-BS	Hanger Bracket, Spreader 3/8"	3
N/S	S-6381	Fitting, Heyco 1247 Black Strain Relief	1

NOTES

GSI Group, LLC Limited Warranty

The GSI Group, LLC ("GSI") warrants products which it manufactures to be free of defects in materials and workmanship under normal usage and conditions for a period of 12 months after sale to the original end-user or if a foreign sale, 14 months from arrival at port of discharge, whichever is earlier. The end-user's sole remedy (and GSI's only obligation) is to repair or replace, at GSI's option and expense, products that in GSI's judgment, contain a material defect in materials or workmanship. Expenses incurred by or on behalf of the end-user without prior written authorization from the GSI Warranty Group shall be the sole responsibility of the end-user.

Warranty Extensions:

The Limited Warranty period is extended for the following products:

	Product	Warranty Period	
AP Fans and Flooring	Performer Series Direct Drive Fan Motor	3 Years	* Warranty prorated from list price: 0 to 3 years - no cost to end-user 3 to 5 years - end-user pays 25% 5 to 7 years - end-user pays 50% 7 to 10 years - end-user pays 75%
	All Fiberglass Housings	Lifetime	
	All Fiberglass Propellers	Lifetime	
AP and Cumberland	Flex-Flo/Pan Feeding System Motors	2 Years	
Cumberland Feeding/Watering Systems	Feeder System Pan Assemblies	5 Years **	** Warranty prorated from list price: 0 to 3 years - no cost to end-user 3 to 5 years - end-user pays 50%
	Feed Tubes (1-3/4" and 2.00")	10 Years *	
	Centerless Augers	10 Years *	
	Watering Nipples	10 Years *	
Grain Systems	Grain Bin Structural Design	5 Years	
Grain Systems Farm Fans Zimmerman	Portable and Tower Dryers	2 Years	† Motors, burner components and moving parts not included. Portable dryer screens included. Tower dryer screens not included.
	Portable and Tower Dryer Frames and Internal Infrastructure †	5 Years	

GSI further warrants that the portable and tower dryer frame and basket, excluding all auger and auger drive components, shall be free from defects in materials for a period of time beginning on the twelfth (12th) month from the date of purchase and continuing until the sixtieth (60th) month from the date of purchase (extended warranty period). During the extended warranty period, GSI will replace the frame or basket components that prove to be defective under normal conditions of use without charge, excluding the labor, transportation, and/or shipping costs incurred in the performance of this extended warranty.

Conditions and Limitations:

THERE ARE NO WARRANTIES THAT EXTEND BEYOND THE LIMITED WARRANTY DESCRIPTION SET FORTH ABOVE. SPECIFICALLY, GSI MAKES NO FURTHER WARRANTY OF ANY KIND, EXPRESS OR IMPLIED, INCLUDING, WITHOUT LIMITATION, WARRANTIES OF MERCHANTABILITY OR FITNESS FOR A PARTICULAR PURPOSE OR USE IN CONNECTION WITH: (I) PRODUCT MANUFACTURED OR SOLD BY GSI OR (II) ANY ADVICE, INSTRUCTION, RECOMMENDATION OR SUGGESTION PROVIDED BY AN AGENT, REPRESENTATIVE OR EMPLOYEE OF GSI REGARDING OR RELATED TO THE CONFIGURATION, INSTALLATION, LAYOUT, SUITABILITY FOR A PARTICULAR PURPOSE, OR DESIGN OF SUCH PRODUCTS.

GSI shall not be liable for any direct, indirect, incidental or consequential damages, including, without limitation, loss of anticipated profits or benefits. The sole and exclusive remedy is set forth in the Limited Warranty, which shall not exceed the amount paid for the product purchased. This warranty is not transferable and applies only to the original end-user. GSI shall have no obligation or responsibility for any representations or warranties made by or on behalf of any dealer, agent or distributor.

GSI assumes no responsibility for claims resulting from construction defects or unauthorized modifications to products which it manufactured. Modifications to products not specifically delineated in the manual accompanying the equipment at initial sale will void the Limited Warranty.

This Limited Warranty shall not extend to products or parts which have been damaged by negligent use, misuse, alteration, accident or which have been improperly/inadequately maintained. This Limited Warranty extends solely to products manufactured by GSI.

Prior to installation, the end-user has the responsibility to comply with federal, state and local codes which apply to the location and installation of products manufactured or sold by GSI.

This equipment shall be installed in accordance with the current installation codes and applicable regulations, which should be carefully followed in all cases. Authorities having jurisdiction should be consulted before installations are made.



**1004 E. Illinois St.
Assumption, IL 62510-0020
Phone: 1-217-226-4421
Fax: 1-217-226-4420
www.gsiag.com**



GSI is a worldwide brand of AGCO Corporation.