

# Scattergrain Grain Spreader Installation and Operating Instructions

## Models:

FFD-200-1

FFD-200-3

## Owner's Manual

PNEG-267

Version: 4.0

Date: 09-12-18



---

**All information, illustrations, photos, and specifications in this manual are based on the latest information available at the time of publication. The right is reserved to make changes at any time without notice.**

# Contents

<b>Chapter 1 Safety</b> .....	<b>4</b>
Safety Guidelines .....	4
Cautionary Symbols Definitions .....	5
Safety Cautions .....	6
Safety Sign-Off Sheet .....	10
<b>Chapter 2 Decals</b> .....	<b>11</b>
<b>Chapter 3 Assembly Instructions</b> .....	<b>13</b>
Hardware List (SPD-2073 and SPD-2074) .....	13
<b>Chapter 4 Wiring and Installation</b> .....	<b>16</b>
1 Phase Dual Voltage Wiring Diagram .....	17
3 Phase Dual Voltage Wiring Diagram .....	17
Grain Spreader Installation .....	18
<b>Chapter 5 Operating Instructions</b> .....	<b>20</b>
Adjustment for Bin Fill .....	21
<b>Chapter 6 Maintenance</b> .....	<b>22</b>
<b>Chapter 7 Troubleshooting</b> .....	<b>23</b>
Correct Spreading Pattern .....	23
<b>Chapter 8 Parts List</b> .....	<b>24</b>
Scattergrain Grain Spreader Parts (FFD-200-1 and FFD-200-3) .....	24
<b>Chapter 9 Warranty</b> .....	<b>27</b>

### Safety Guidelines

Safety guidelines are general-to-specific safety rules that must be followed at all times. This manual is written to help you understand safe operating procedures and problems that can be encountered by the operator and other personnel when using this equipment. Save these safety guidelines for future reference.

As owner or operator, you are responsible for understanding the requirements, hazards, and precautions that exist and to inform others as required. Unqualified persons must stay out of the work area at all times.

Alterations must not be made to the equipment. Alterations can produce dangerous situations resulting in **SERIOUS INJURY** or **DEATH**.

This equipment must be installed in accordance with the current installation codes and applicable regulations, which must be carefully followed in all cases. Authorities having jurisdiction must be consulted before installations are made.

When necessary, you must consider the installation location relative to electrical, fuel and water utilities.

Personnel operating or working around equipment must read this manual. This manual must be delivered with equipment to its owner. Failure to read this manual and its safety instructions is a misuse of the equipment.

**ST-0001-3**

## Cautionary Symbols Definitions

Cautionary symbols appear in this manual and on product decals. The symbols alert the user of potential safety hazards, prohibited activities and mandatory actions. To help you recognize this information, we use the symbols that are defined below.



This symbol indicates an imminently hazardous situation which, if not avoided, **will result in serious injury or death.**



This symbol indicates a potentially hazardous situation which, if not avoided, **can result in serious injury or death.**



This symbol indicates a potentially hazardous situation which, if not avoided, **can result in minor or moderate injury.**



This symbol is used to address practices not related to personal injury.



This symbol indicates a general hazard.



This symbol indicates a prohibited activity.

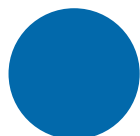

This symbol indicates a mandatory action.

ST-0005-2

## 1. Safety

### Safety Cautions

#### Use Personal Protective Equipment

- Use appropriate personal protective equipment:

**Eye Protection**



**Respiratory Protection**



**Foot Protection**



**Hearing Protection**



**Head Protection**



**Fall Protection**



**Hand Protection**



- Wear clothing appropriate to the job.
- Remove all jewelry.
- Tie long hair up and back.

ST-0004-1

#### Follow Safety Instructions

- Carefully read all safety messages in this manual and safety signs on your machine. Keep signs in good condition. Replace missing or damaged safety signs. Be sure new equipment components and repair parts include the current safety signs. Replacement safety signs are available from the manufacturer.
- Learn how to operate the machine and how to use controls properly. Do not let anyone operate without instruction.
- If you do not understand any part of this manual or need assistance, contact your dealer.



ST-0002-1

### Maintain Equipment and Work Area

- Understand service procedures before doing work. Keep area clean and dry.
- Never service equipment while it is operating. Keep hands, feet, and clothing away from moving parts
- Keep your equipment in proper working condition. Replace worn or broken parts immediately.



ST-0003-1

### Lifting Hazard

- Single person lift can cause injury.
- Use a mechanical lifting device to lift or move the equipment during installation.



ST-0021-2

### Sharp Edge Hazard

- This product has sharp edges, which can cause serious injury.
- To avoid injury, handle sharp edges with caution and always use proper protective clothing and equipment.



ST-0036-2

### Operate Motor Properly

- All electrical connections must be made in accordance with applicable local codes (National Electrical Code for the US, Canadian Electric Code, or EN60204 along with applicable European Directives for Europe). Make sure equipment and bins are properly grounded.
- Lock-out power before resetting motor overloads.
- Do not repetitively stop and start the drive in order to free a plugged condition. Jogging the drive in this manner can damage the equipment and drive components.

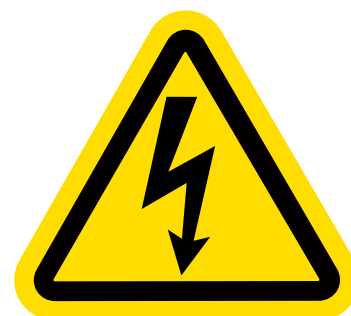

ST-0009-3

## 1. Safety

### Do Not Enter Bin

- Rotating flighting will kill or dismember.
- Flowing material will trap and suffocate.
- Crusted material will collapse and suffocate.
  - If you must enter the bin:
    1. Shut off and lock out all power sources.
    2. Use a safety harness and safety line.
    3. Station another person outside the bin.
    4. Avoid the center of the bin.
    5. Wear proper breathing equipment or respirator.



ST-0061-1



## Confined Space Hazards and Entry Procedures

- Note that the interior of this equipment is considered a confined space. Maintenance of this equipment can require access to the confined space.
- Access doors must be shut and locked except when access is required.
- Doors giving access to dangerous equipment must be safety interlocked.
- The following entry procedures must be followed:
  - Be aware of all possible hazards present inside the confined space and wear personal protective equipment (PPE) as needed.
  - Complete a permit to work and follow all permit required confined space entry procedures defined by the site manager.
  - Make sure that the area has been purged of any hazardous products or gases. Check the atmosphere for harmful gases or vapors with a suitable gas analyzer and make sure levels are safe before entering.
  - Do not smoke or use naked flames.
  - Lock out and tag out power supplies and fuel supplies to all equipment.
  - Do not work alone. Work in teams of at least three so that help is immediately available in the event of an emergency.
  - Confirm that all personnel have safely exited the equipment and tools have been recovered once work is complete.



ST-0055-1



GSI Group recommends contacting your local power company and having a representative survey your installation so the wiring is compatible with their system and adequate power is supplied to the unit.

Safety decals should be read and understood by all people in the grain handling area. Decal (DC-GBC 1A) [on Page 12](#) should be present on the inside bin door cover of the 2 ring door, on the cover of the 24" porthole door and on the roof manway cover.

If a decal is damaged or is missing contact:

Contact:

**GSI Decals**

1004 E. Illinois St.  
Assumption, IL. 62510  
Phone: 1-217-226-4421

A free replacement will be sent to you.

**NOTE:** *Decals not to scale.*





# DANGER



Rotating flighting will kill or dismember.



Flowing material will trap and suffocate.



Crusted material will collapse and suffocate.

## Keep clear of all augers. DO NOT ENTER this bin!

If you must enter the bin:

1. Shut off and lock out all power.
2. Use a safety harness and safety line.
3. Station another person outside the bin.
4. Avoid the center of the bin.
5. Wear proper breathing equipment or respirator.

## Failure to heed these warnings will result in serious injury or death.

GSI GROUP, INC. 217-226-4421

DC-GBC-1A

DC-GBC-1A

## Hardware List (SPD-2073 and SPD-2074)

Ref #	Part #	Description	Qty
11	SPD-2008	Hanger Extension	3
12	SPD-2149	Hanger Bracket	3
23	S-7483	Flange Bolt 5/16"-18 x 1-1/4" JS500 Grade 8 or 8.2	12
28	S-1147	Split Lock Washer 5/16" ZN	38
29	S-10268	Flange Nut 5/16"-18 JS500 Grade 5	34
31	S-845	Flat Washer 5/16" USS ZN	28
33	S-6078	Set Screw 5/16"-18 x 1/4" SKT HD BK Cup Point	2
34	S-6079	1/4" x 1" Roll Pin	1
37	*	3/8" Eye Bolt	1
	00405341	Danger Decal	1

Refer to [Page 24](#) for the assembly drawing and [Page 25](#) for the part list.

The Scattergrain is a direct drive spreader. The unit is powered by a totally enclosed, 1 HP motor. Two (2) types of motors are offered with the super spread. One has a 1 phase motor (FFD-200-1) and the other model has a 3 phase motor. (See [Figure 3A.](#)) Maximum grain capacity is 4000 to 6000 bushels per hour, depending on moisture content, weight and fines evenly throughout the bin. This will help prevent uneven drying.

1. Carefully unpack the unit and inspect for shipping damage. (See [Figure 3A.](#))
2. Check tightness of all bolts in the cone (C) and blade assemblies (D).

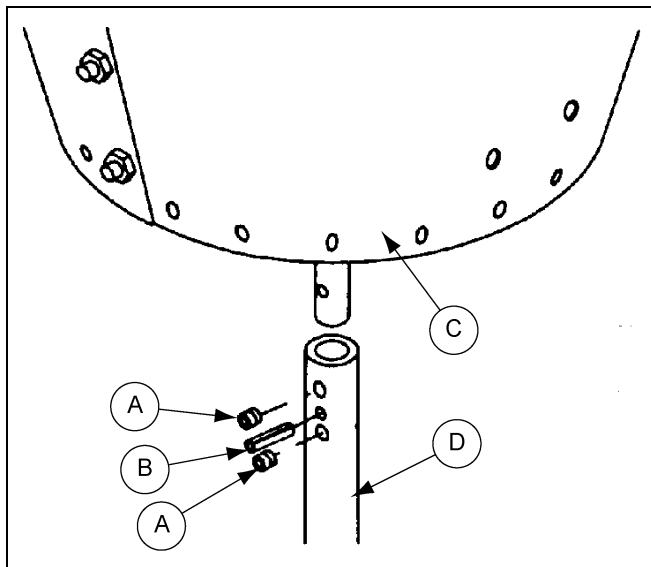

Ref #	Description
A	1/4" Set Screw
B	1/4" x 1" Roll Pin
C	Cone Assembly
D	Blade Assembly

**Figure 3A** Spreader Cone Assembly and Blade Assembly Connection

### 3. Assembly Instructions

- Remove blade extension from blade assembly for 24' diameter bins and smaller. (See Figure 3B.)
- Turn the three (3) spreader diverters (I) outward. The diverters on the blade assembly are turned inward for shipping purposes. Further adjustments may be required after installation. (See Figure 3B.)

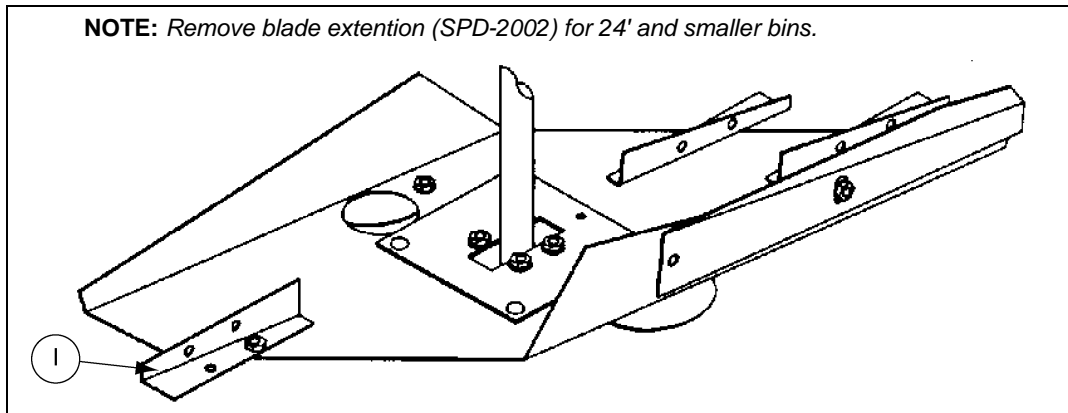

**Figure 3B** The diverter segments on the blade.

- Use two (2) 5/16"-18 x 1-1/4" bolts (F), four (4) 5/16" flat washers (E), two (2) 5/16" lock washers (H), and two (2) 5/16"-18 nuts (G) to fasten each of the three (3) hanger brackets (K) inside the spreader cone. (See Figure 3C.) The five (5) mounting slots provided in the hanger brackets (K) are used for adjusting (J) the spreader up and down inside the bin. Location is dependent on several factors such as interference with stirring systems and grain bouncing off spreader motor onto bin roof.
- Measure bin opening (hatch collar) to select correct slots for bolting hanger extensions (L) to hanger brackets (K). All GSI bins with standard peak roof cap have a hatch collar diameter 31-1/2". Loosely mount each hanger extension (L) to a hanger bracket (K), using the appropriate slots with two (2) 5/16"-18 x 1-1/4" bolts (F), two (2) 5/16" lock washers (H), four (4) 5/16" flat washers (E) and two (2) 5/16"-18 nuts (G). (See Figure 3C.)

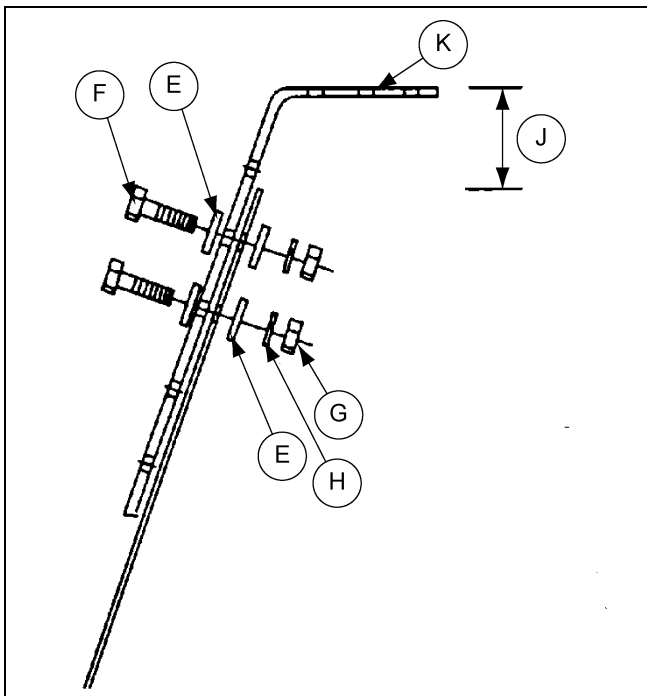

**Figure 3C** The spreader cone connection to the hanger bracket.

Ref #	Description
E	5/16" Flat Washer
F	5/16"-18 x 1-1/4" Bolt
G	5/16"-18 Nut
H	5/16" Lock Washer
I	Turn Spreader Diverter (SPD-2003)
J	Adjustable
K	Hanger Bracket (SPD-2149)

7. Add 3/8" eye bolt to the top of motor.
8. Compare assembled unit with parts assembly drawing (See Page 24) to make certain that all parts are properly installed.

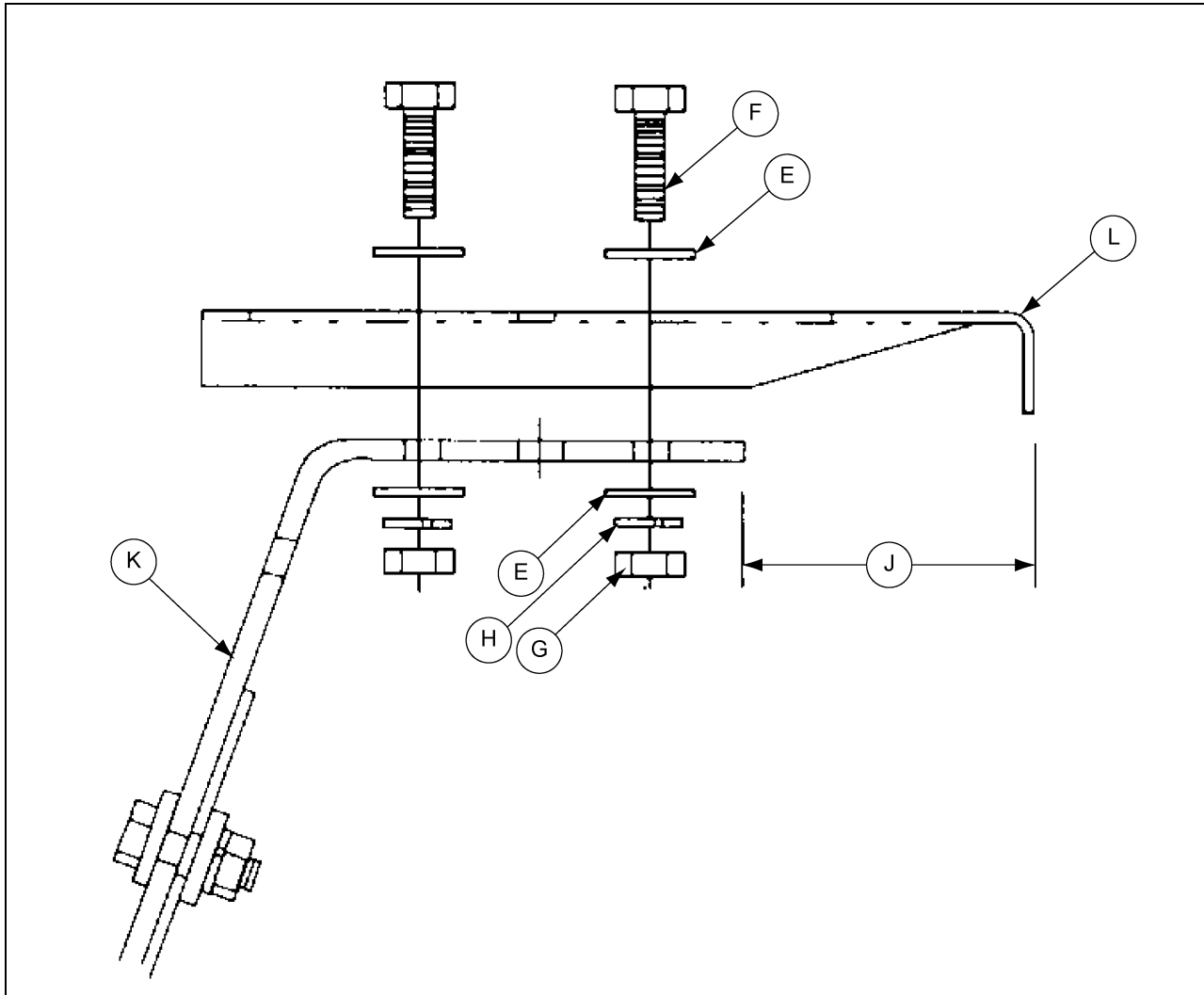

**Figure 3D** The hanger bracket connection to the hanger extension.

Ref #	Description
E	5/16" Flat Washer
F	5/16"-18 x 1-1/4" Bolt
G	5/16"-18 Nut
H	5/16" Lock Washer
J	Adjustable
K	Hanger Bracket (SPD-2149)
L	Hanger Extension (SPD-2008)

## 4. Wiring and Installation

The units are shipped with the motor wires disconnected. Carefully connect motor wires for desired operating voltage as indicated on the wiring diagram [on Page 17](#). Model SPD-2073 will be wired for 230V. The other models will not. Be certain to use electrical connectors of adequate size. The table [below](#) provides wire size information.

The 1 HP motor is protected with an internal automatic reset overload. However, it is advisable to provide additional protection with fuse or circuit breaker.

The motor should turn the spreader blade counterclockwise as viewed from above the unit. If the 3 phase unit turns clockwise, the rotation can be changed.

This may be done by interchanging any 2 of the 3 power wire connections. The rotation cannot be reversed on single phase unit.

Make sure eye bolt is securely fastened to motor before installing spreader. **DO NOT STAND UNDERNEATH UNIT WHILE IT IS LIFTED INTO PLACE.**

	1 HP Spreader Motor				
	1750 RPM				
	1 Phase		3 Phase		
	110V	230V	208V	230V	460V
Full Load Amps	9.4	4.7	3	2.8	1.4
Minimum Wire Size					
Copper Wire					
50' Run	14	14	14	14	14
100' Run	12	14	14	14	14
150' Run	10	14	14	14	14
200' Run	8	14	14	14	14
Aluminum Wire					
50' Run	12	12	12	12	12
100' Run	10	12	12	12	12
150' Run	8	12	12	12	12
200' Run	6	12	12	12	12
Fuse Size (Slow-Blow)	20	15	10	10	5
Breaker Size	25	20	15	15	10

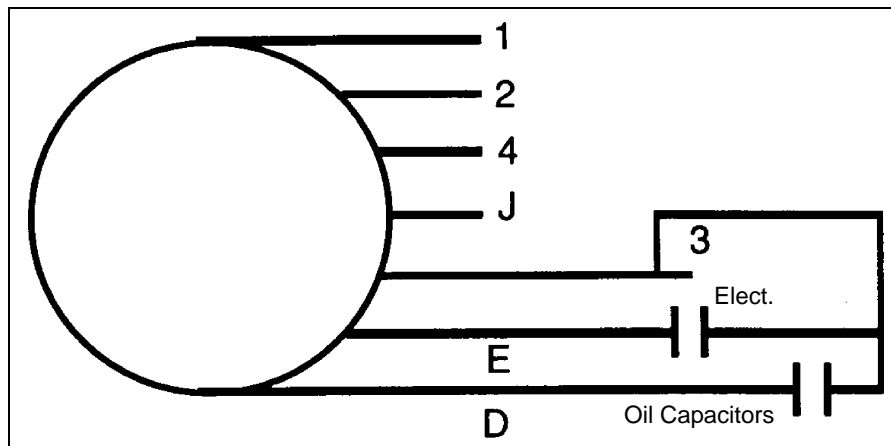

Figure 4A



## 1 Phase Dual Voltage Wiring Diagram

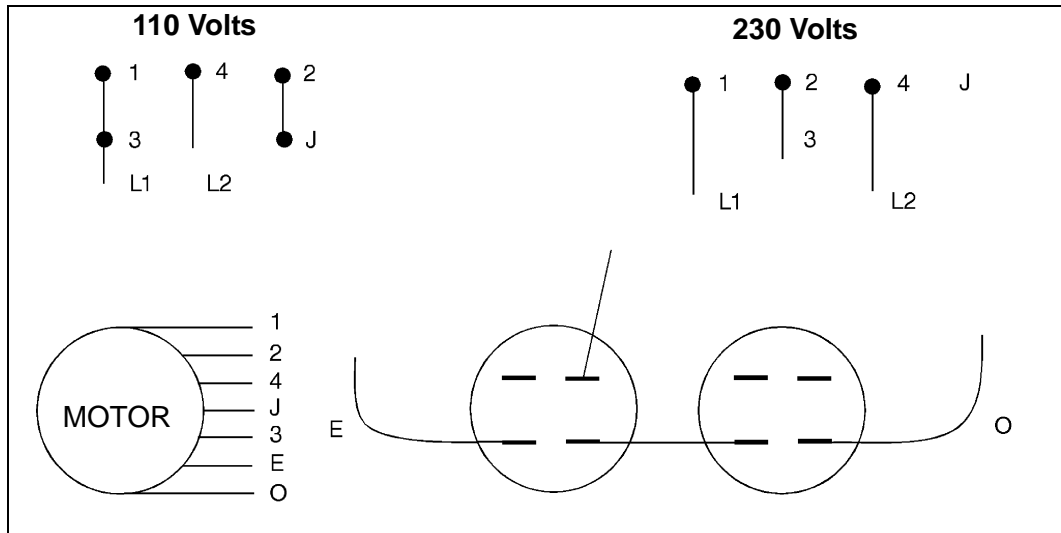

Figure 4B

- For 110 volts 1, 3 and the extra wire on the capacitor go to L1.
- 4 goes to L2, and 2 and J tie together.
- “E” from the motor goes to “E” on the capacitor.
- “O” from the motor goes to “O” on the capacitor.
- For 230 volts 1 goes to L1.
- 2 and 3 and the extra wire on the capacitor go together.
- 4 goes to L2.
- “J” is tied off by itself.
- “E” from the motor goes to “E” on the capacitor.
- “O” from the motor goes to “O” on the capacitor.

## 3 Phase Dual Voltage Wiring Diagram

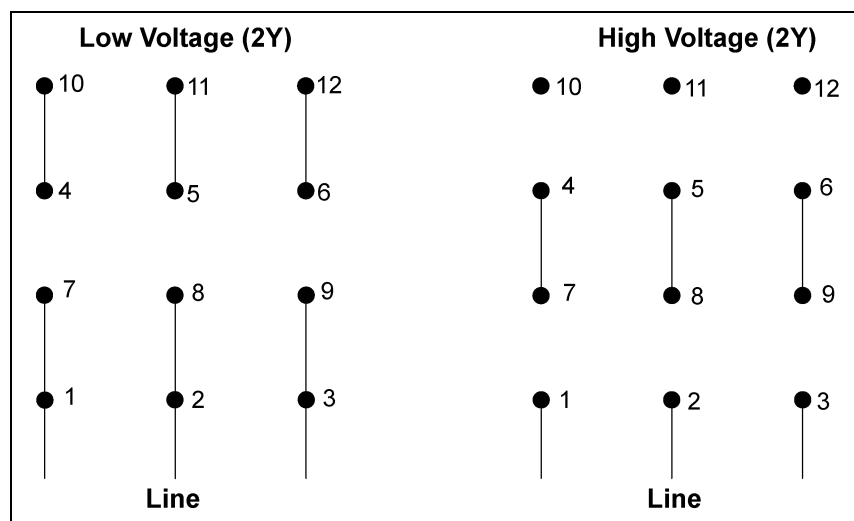

Figure 4C

## 4. Wiring and Installation

### Grain Spreader Installation

1. Adjust hanger extensions to fit roof opening and install the power spread unit.
2. Use the 9/32" hole at the end of each hanger extension and bolt hanger extensions to hatch collar.
3. Then tighten all bolts holding hanger extensions.
4. Once unit is installed, use a carpenter's level across the top of the spreader cone to make sure it is level in all directions. (See Figure 4D.)

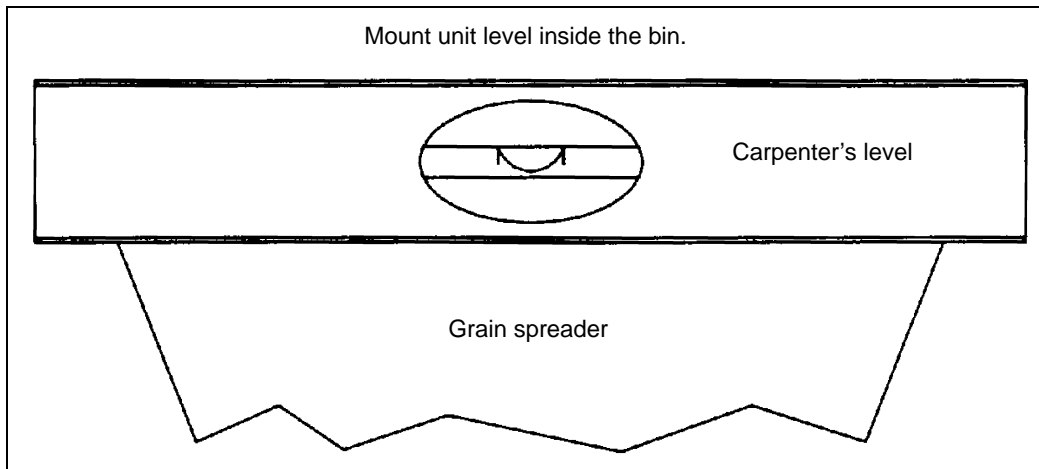

Figure 4D

5. If required, add spacer washers (C) between hanger brackets (A) and hanger extensions (B) to level unit. (See Figure 4E.)

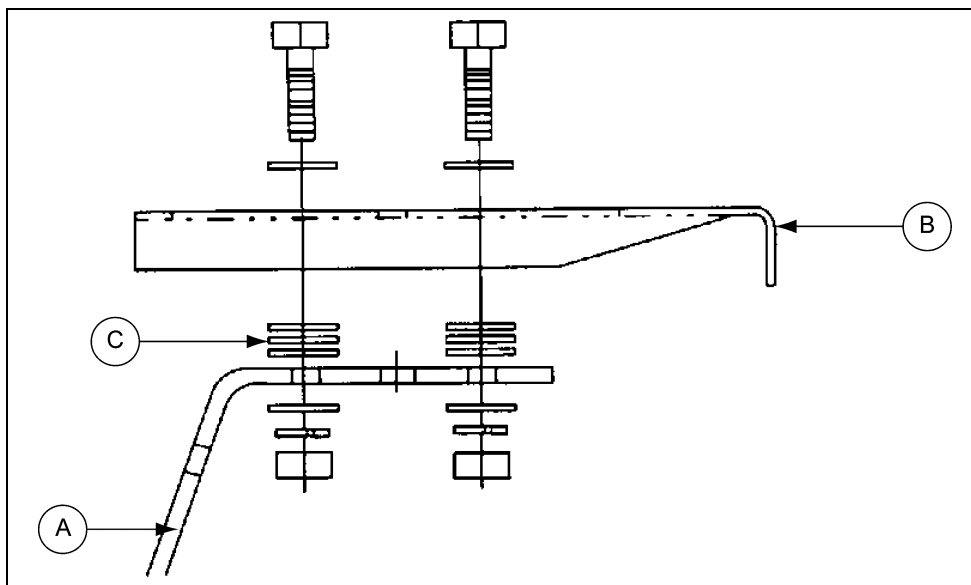

Figure 4E

Ref #	Part #	Description
A	SPD-2149	Hanger Bracket
B	SPD-2008	Hanger Extension
C		Use washers to level unit (if required)



The 1 HP motor is protected with an internal automatic reset overload. Before servicing, all power to the unit must be disconnected and locked out to avoid a possible reset/restart and serious injury.

Before connecting and applying power, rotate the spreader blade by hand to be certain it rotates freely without obstruction. The motor turns the spreader blade counterclockwise as viewed from above the unit. The super spread unit requires 115 or 230 volt 1 PH or 230 or 460 volt 3 phase power supply. The minimum wire size is 14 gauge for runs up to 200'. It is advisable to provide additional protection such as 15 Amp slow blow fuses or 20 Amp circuit breaker. Consult a licensed electrician for wire size on longer runs. Regardless of grain type and bin size, the grain flow must be directly down (vertical) and centered (horizontal) within the spreader cone. (See Figure 4F.) This has to be done to prevent high and low grain surface areas from one side of the bin to the other.

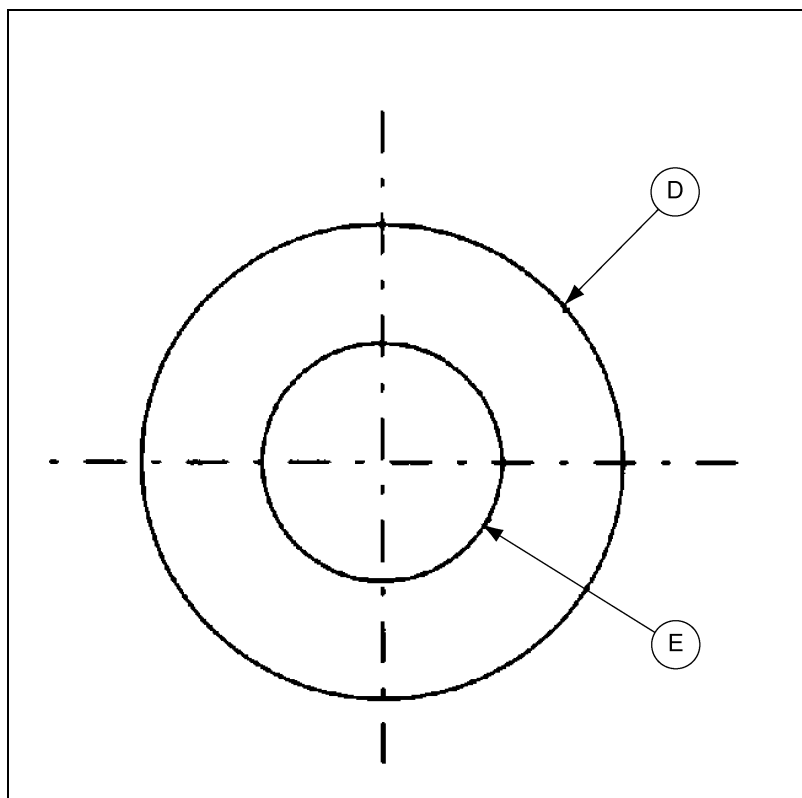

Figure 4F Grain flow must be centered within the spreader cone.

Ref #	Part #	Description
D	SPD-2061	Spreader Cone
E		Grain Flow

## 5. Operating Instructions

The grain spreader blade assembly has four (4) features for adjusting grain flow pattern.

1. Tilt is the adjustment of the entire spreader blade, which controls overall grain spreading. Tilt is adjusted by loosening the two (2) U-bolts that allow the tipping of the blade up and down. This may vary according to bin diameter and fill rate. (See Figure 5A.)

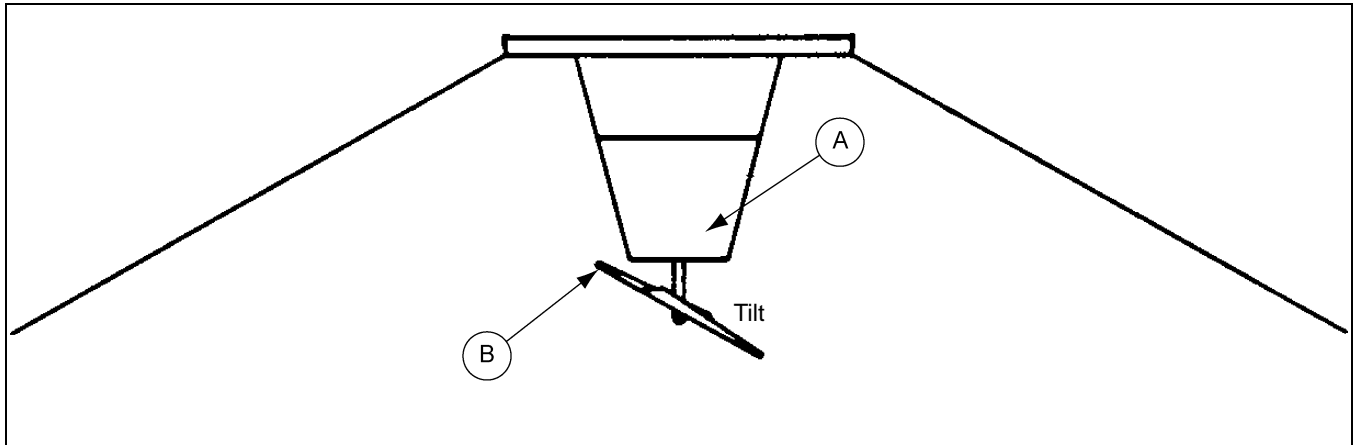

**Figure 5A** Adjustment of the Tilt

Ref #	Description
A	Grain Spreader
B	Single spreader diverter end up for desired grain spread.

2. Spreader diverters (D) are used to increase or decrease grain flow resistance over spreader blade (C). With the diverters straight (See Figure 5B) the grain will travel further. Angled grain diverters will reduce the throwing distance.

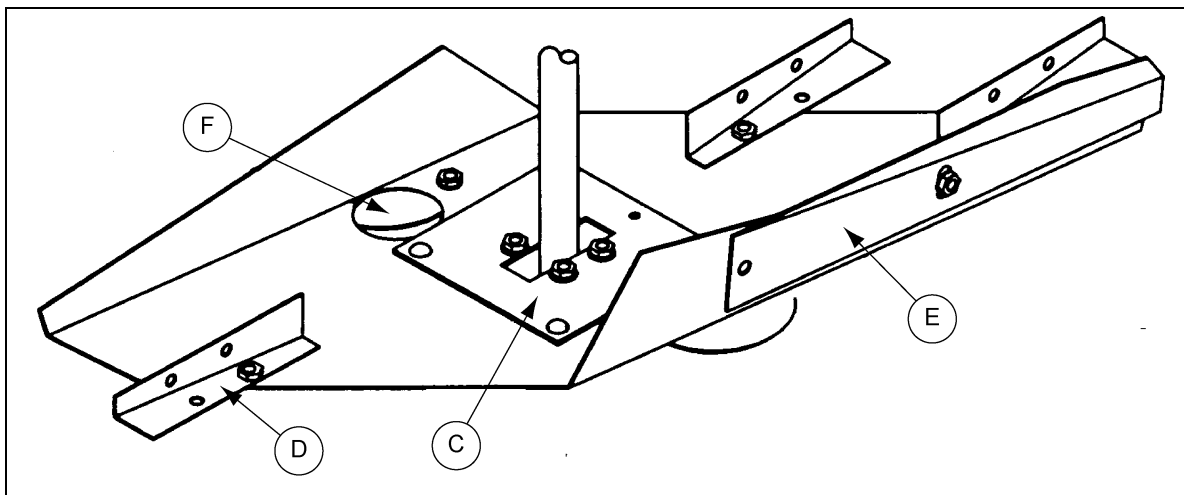

**Figure 5B** Four (4) features for adjusting the grain flow pattern.

Ref #	Description
C	Spreader Blade
D	Spreader Diverters

Ref #	Description
E	Blade Extension
F	Damper

3. Blade extension (E) is used when extra throwing distance is required for larger bins.
4. Dampers (F) are used to control center filling.

## Adjustment for Bin Fill

Ref #	Part	Type	Large Bin 36" Diameter and Greater	Small Bin 24" Diameter and Less
			Operation/Procedure	Operation/Procedure
C	Spreader Blade	Tilt	Decrease (flatten)/loosen U-bolts and pivot the blade to horizontal. Always refer to single diverter side as gauge.	Increase/loosen U-bolts and pivot the blade (single diverter side) upward.
D	Spreader Diverter	Single Side	Decrease (center filling)/loosen bolts and rotate diverter clockwise.	Increase (center filling)/loosen bolt and rotate diverter counterclockwise.
		Dual Side	Decrease (center filling)/loosen bolts and rotate diverters clockwise to direct flow in line with grain stream.	Increase (center filling)/loosen bolt and rotate diverters counterclockwise to direct flow across grain stream.
E	Blade Extension	Tilt	Increase/loosen bolt and pivot the extension upward to maximum allowance in slotted hole.	Remove blade extension.
F	Damper	Opening	Decrease (center filling)/loosen bolts and pivot dampers to nearly closed position.	Increase (center filling)/loosen bolts and pivot dampers to almost fully open position.

Ref # refers to [Figure 5B on Page 20](#).

1. Rotation is always viewed from top of the unit looking down onto the blade.
2. Be sure to fully tighten all bolts after each adjustment is made.
3. These adjustments describe the requirements for both extremes of bin sizes. For bin sizes between 24' and 36' in diameter start with intermediate adjustments, then vary slightly as required.

## 6. Maintenance

For normal operation, annually relubricate both motor bearings with approximately ten (10) drops of 5W-30 oil. The gears of the gearbox assembly are lubricated with a special high temperature, food grade lubricant (SPD-2109) at the time of manufacturing. The level of grease in the gearbox should be checked annually and will normally not require further lubrication unless seal breakage occurs. After the grease has settled to the bottom of the gearbox, the grease level can be checked. The grease level should not be more than 1/4" below the vent plug. (See Figure 6A.) It may be necessary to insert a wire through vent plug hole to find the grease level. The level also can be checked by removing motor and viewing grease level through hole for motor pinion gear.

Inspect seals annually for signs of leakage (check bearings annually for tightness).

In the event the motor fails to start, check power supply to the motor. If power supply exists and motor still fails to start, disconnect power and check blade for freedom of rotation. If power does not exist, check for blown fuse or flipped circuit breaker.

If motor stops operating for no apparent reason, wait approximately five minutes for the automatic overload protection device to reset and reattempt operation. If problem continues, check power supply for voltage and check blade of unit for freedom of rotation.

If motor pinion requires removal for any reason, it must be properly installed and located, as shown in the parts assembly [on Page 24](#).



**Disconnect power supply before attempting any type of service. The motor is protected with a self-resetting overload protection.**



**Failure to disconnect power can result in serious injury or death.**

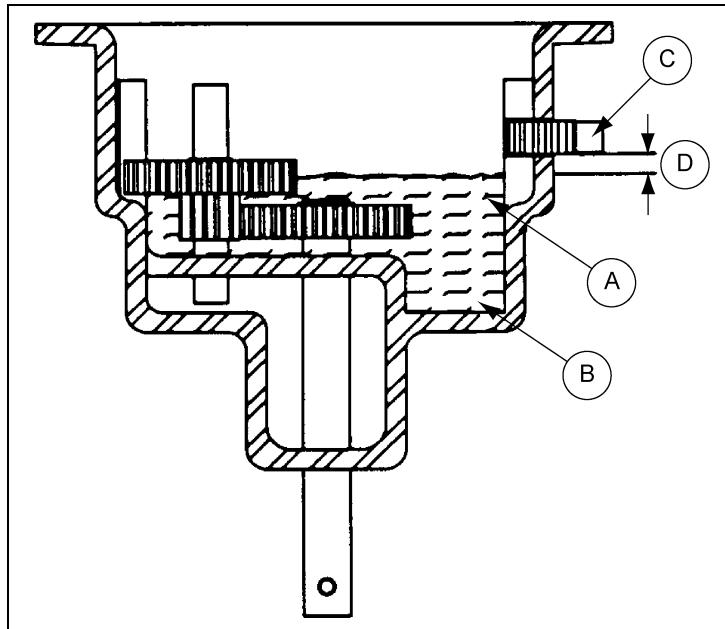

**Figure 6A** The gearbox assembly showing grease level.

Ref #	Part #	Description
A	SPD-2109	Special Lubricant
B	SPD-2154	Spreader Gearbox Assembly

Ref #	Description
C	Vent Plug
D	1/4" Minimum Grease Level

## Correct Spreading Pattern

Grain is slightly depressed in the center, grain flow is centered and the spreader is level.

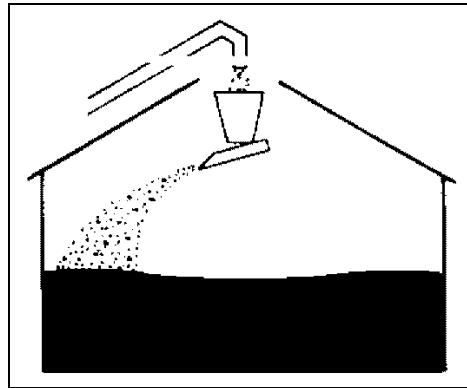
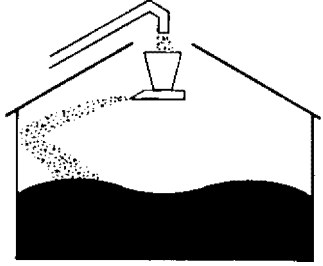
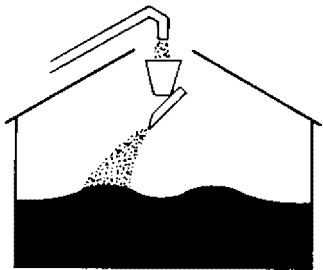
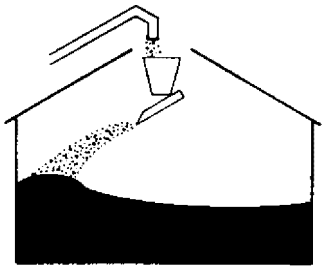

Figure 7A

Grain is slightly depressed in the center, grain flow is centered and the spreader is level.

Trouble	Probable Cause	Illustration
Large doughnut shaped ring caused by grain hitting high on bin wall.	Tilt blade downward, decrease bite. Remove blade extension.	 <p>Spreader blade too flat.</p>
Grain is high in center of bin, small doughnut.	Flatten blade, increase bite, decrease grain flow to spreader. Add blade extension.	 <p>Spreader blade too steep.</p>
Grain is high on one side of bin.	Level spreader, correct grain flow to spreader, (never allow grain to flow into spreader at an angle or off center).	 <p>Not level, not centered.</p>

## 8. Parts List

# Scattergrain Grain Spreader Parts (FFD-200-1 and FFD-200-3)



Automatic reset overload protection.

**NOTE:** Tighten set screws against flat on motor shaft.

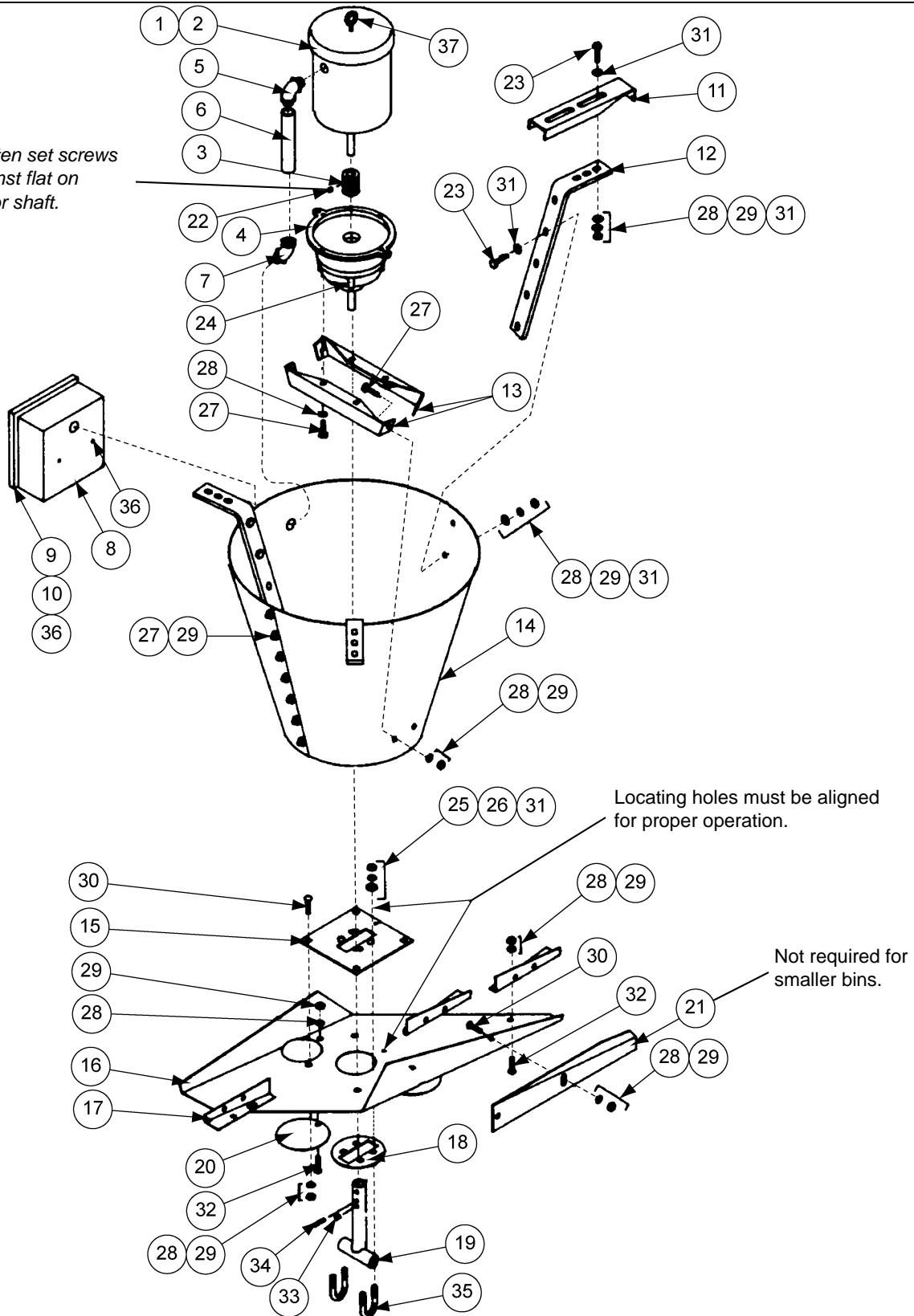



## Scattergrain Grain Spreader Parts List for FFD-200-1 and FFD-200-3

Ref #	Part #	Description	Qty
1	002-1105-2	Motor, 1 HP 1 PH 17 56 TENV SH DI Replaces SPD-2071 on 10/09/01 TMH	1
2	MTR-0231	Motor, 1 HP 1760/1460RPM 208-230/460//190/380 3 PH 60/50 Hz 56C TE	1
3	017-1534-1	Sleeve, Pinion Gearbox 11:1 FF	1
4	SPD-2154	Gearbox, 1 HP, MI-10-CE Color: Blue Oil Seal: 1	1
5	TFC-0054	Elbow, 3/4" Sealtite CSA	1
6	FH-6563	Fitting, Sealtite 3/4" CSA Approved	1
7	SPD-2151	Fitting, 3/4" Sealtite 45° Metallic Fitting for 3/4" Metallic Sealtite	1
8	SPD-2068	Capacitor Box	1
9	SPD-2069	Capacitor Box Lid	1
10	SPD-2070	Capacitor Clip	1
11	SPD-2008	Hanger Extension	3
12	SPD-2149	Hanger Bracket	3
13	SPD-2062	Gearbox Mounting Bracket	2
14	SPD-2061	Spreader Cone	1
15	SPD-2004	Upper Back-Up Plate	1
16	SPD-2063	Spreader Blade	1
17	SPD-2003	Spreader Diverter	3
18	SPD-2005	Lower Back-Up Plate	1
19	SPD-2013-BS	Drive Shaft Weldment	1
20	SPD-2006	Damper	2
21	SPD-2064	Blade Extension	1
22	*	Set Screw	1
23	S-7483	Flange Bolt 5/16"-18 x 1-1/4" JS500 Grade 8 or 8.2 Full Thread with Sealing Washer	12
24	SPD-2109	Special Gearbox Lubricant	*
25	S-1054	Split Lock Washer 3/8" ZN Clear	4
26	S-7489	Hex Nut 3/8"-16 JS500 Grade 5	4
27	S-6606	Flange Bolt 5/16"-18 x 3/4" ZN Clear Grade 5	15
28	S-1147	Split Lock Washer 5/16" ZN	38
29	S-10268	Flange Nut 5/16"-18 JS500 Grade 5	34
30	S-6076	Carriage Bolt 5/16"-18 x 3/4" ZN Grade 2	6
31	S-845	Flat Washer 5/16" USS ZN	6
32	S-6606	Flange Bolt 5/16"-18 x 3/4" ZN Clear Grade 5	5
33	S-6078	Set Screw 5/16"-18 x 1/4" SKT HD BK Cup Point	2
34	S-6079	Pin, Spring 1/4" x 1" Plain Steel Slotted Rolled	1
35	S-6077	U-Bolt, 3/8"-16 x 1W x 2-1/4" LG ZN	2
36	S-7621	Screw, SDS #10-16 x 1 HWH ZN Grade 2 Hex Head-Dril-Kwick Hex Wash HD	4
37	*	3/8" Eye Bolt	1
	SPD-2108	Spreader Blade Replacement Assembly 1 HP	
	TFH-2104	Capacitor, Start 216MFD 250VAC Baldor #EC1216C06 Electrolytic CA	1
	FH-7001	OC3020F12 Capacitor (1 Phase)	1

\* Denotes items included in the gearbox assembly.

All parts are standard except for the Ref #'s 1, 2, 10, 36 and 37. (See description for applications.)

---

# NOTES

## GSI Group, LLC Limited Warranty

The GSI Group, LLC ("GSI") warrants products which it manufactures to be free of defects in materials and workmanship under normal usage and conditions for a period of 12 months after sale to the original end-user or if a foreign sale, 14 months from arrival at port of discharge, whichever is earlier. The end-user's sole remedy (and GSI's only obligation) is to repair or replace, at GSI's option and expense, products that in GSI's judgment, contain a material defect in materials or workmanship. Expenses incurred by or on behalf of the end-user without prior written authorization from the GSI Warranty Group shall be the sole responsibility of the end-user.

### Warranty Extensions:

The Limited Warranty period is extended for the following products:

	Product	Warranty Period	
<b>AP Fans and Flooring</b>	Performer Series Direct Drive Fan Motor	3 Years	* Warranty prorated from list price: 0 to 3 years - no cost to end-user 3 to 5 years - end-user pays 25% 5 to 7 years - end-user pays 50% 7 to 10 years - end-user pays 75%
	All Fiberglass Housings	Lifetime	
	All Fiberglass Propellers	Lifetime	
<b>AP and Cumberland</b>	Flex-Flo/Pan Feeding System Motors	2 Years	
<b>Cumberland Feeding/Watering Systems</b>	Feeder System Pan Assemblies	5 Years **	** Warranty prorated from list price: 0 to 3 years - no cost to end-user 3 to 5 years - end-user pays 50%
	Feed Tubes (1-3/4" and 2.00")	10 Years *	
	Centerless Augers	10 Years *	
	Watering Nipples	10 Years *	
<b>Grain Systems</b>	Grain Bin Structural Design	5 Years	
<b>Grain Systems Farm Fans Zimmerman</b>	Portable and Tower Dryers	2 Years	† Motors, burner components and moving parts not included. Portable dryer screens included. Tower dryer screens not included.
	Portable and Tower Dryer Frames and Internal Infrastructure †	5 Years	

GSI further warrants that the portable and tower dryer frame and basket, excluding all auger and auger drive components, shall be free from defects in materials for a period of time beginning on the twelfth (12<sup>th</sup>) month from the date of purchase and continuing until the sixtieth (60<sup>th</sup>) month from the date of purchase (extended warranty period). During the extended warranty period, GSI will replace the frame or basket components that prove to be defective under normal conditions of use without charge, excluding the labor, transportation, and/or shipping costs incurred in the performance of this extended warranty.

### Conditions and Limitations:

THERE ARE NO WARRANTIES THAT EXTEND BEYOND THE LIMITED WARRANTY DESCRIPTION SET FORTH ABOVE. SPECIFICALLY, GSI MAKES NO FURTHER WARRANTY OF ANY KIND, EXPRESS OR IMPLIED, INCLUDING, WITHOUT LIMITATION, WARRANTIES OF MERCHANTABILITY OR FITNESS FOR A PARTICULAR PURPOSE OR USE IN CONNECTION WITH: (I) PRODUCT MANUFACTURED OR SOLD BY GSI OR (II) ANY ADVICE, INSTRUCTION, RECOMMENDATION OR SUGGESTION PROVIDED BY AN AGENT, REPRESENTATIVE OR EMPLOYEE OF GSI REGARDING OR RELATED TO THE CONFIGURATION, INSTALLATION, LAYOUT, SUITABILITY FOR A PARTICULAR PURPOSE, OR DESIGN OF SUCH PRODUCTS.

GSI shall not be liable for any direct, indirect, incidental or consequential damages, including, without limitation, loss of anticipated profits or benefits. The sole and exclusive remedy is set forth in the Limited Warranty, which shall not exceed the amount paid for the product purchased. This warranty is not transferable and applies only to the original end-user. GSI shall have no obligation or responsibility for any representations or warranties made by or on behalf of any dealer, agent or distributor.

GSI assumes no responsibility for claims resulting from construction defects or unauthorized modifications to products which it manufactured. Modifications to products not specifically delineated in the manual accompanying the equipment at initial sale will void the Limited Warranty.

This Limited Warranty shall not extend to products or parts which have been damaged by negligent use, misuse, alteration, accident or which have been improperly/inadequately maintained. This Limited Warranty extends solely to products manufactured by GSI.

Prior to installation, the end-user has the responsibility to comply with federal, state and local codes which apply to the location and installation of products manufactured or sold by GSI.

This equipment shall be installed in accordance with the current installation codes and applicable regulations, which should be carefully followed in all cases. Authorities having jurisdiction should be consulted before installations are made.



1004 E. Illinois St.  
Assumption, IL 62510-0020  
Phone: 1-217-226-4421  
Fax: 1-217-226-4420  
[www.gsiag.com](http://www.gsiag.com)



GSI is a worldwide brand of AGCO Corporation.