



1. Insert the monorail leg (2) vertically at the joint between the ends of the monorails (1), centering the leg (2) on the splice as shown in [Figure 1](#).

NOTE: Lock the monorail leg (2) securely into the monorails (1) using the locking tabs (5).

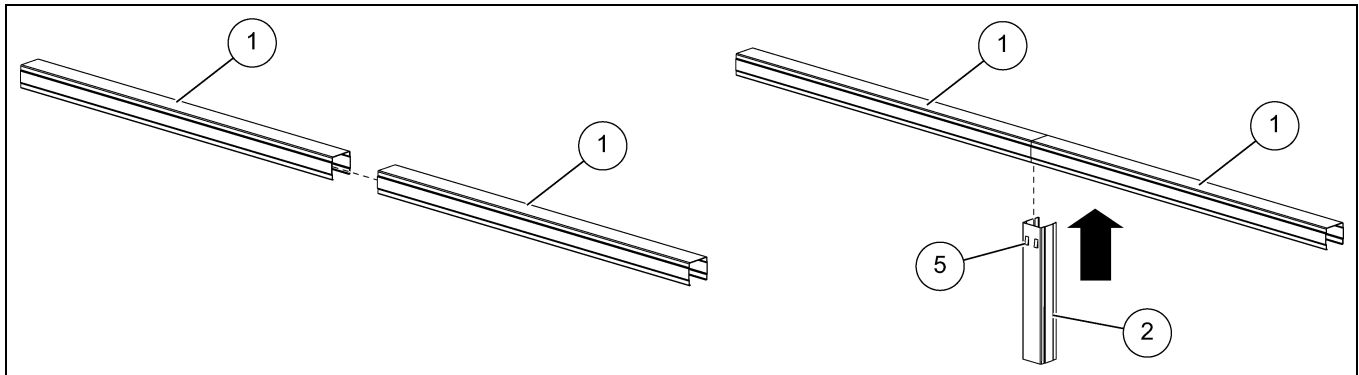

Figure 1 Installing the Monorail Leg

Ref #	Part #	Description
1	FL-403-1	Rails for Monorail Per Foot
2*	FL-403-X	Monorail Leg

Ref #	Description
5	Leg Locking Tabs

2. Use the four self-tapping screws (3) to secure the monorails (1) to the monorail leg (2) as shown in [Figure 2](#). (**NOTE:** See the orientation of the monorail leg (2) in [Figure 2](#).)

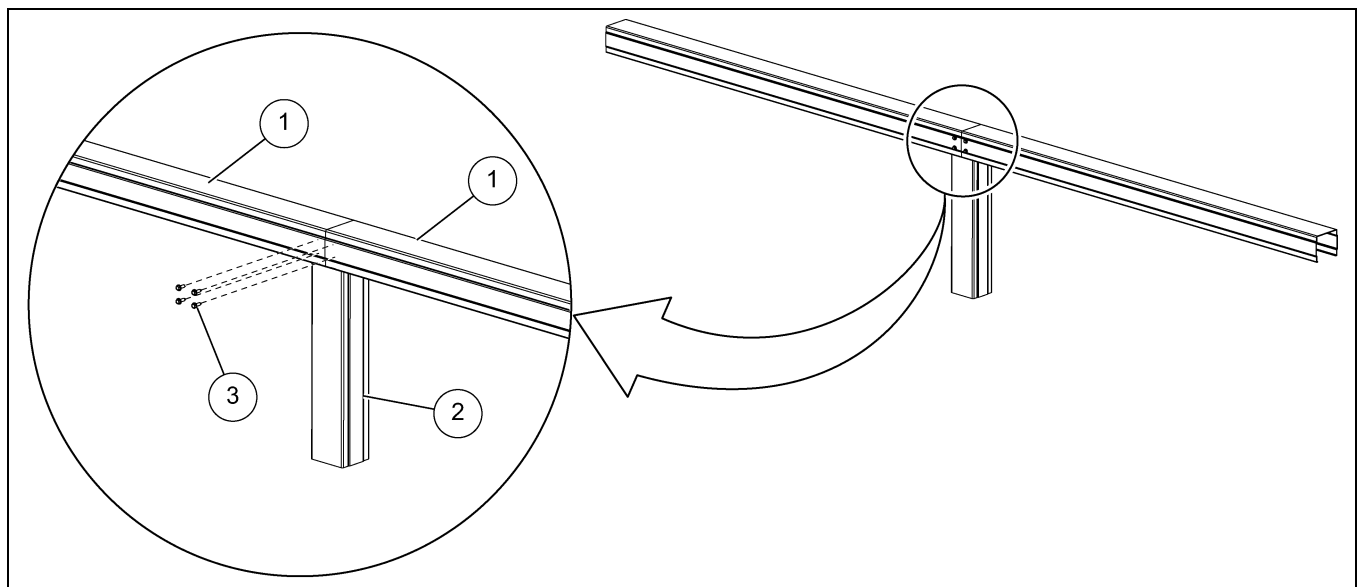

Figure 2 Installing the Screws in the Monorail

Ref #	Part #	Description
1	FL-403-1	Rails for Monorail Per Foot
2*	FL-403-X	Monorail Leg
3	S-280	Screw, SDS #10-16 x 5/8" HWH ZN

* **NOTE:** "X" denotes the monorail leg part number extension.



Monorail Splice Detail

3. Use the four self-tapping screws (3) and the monorail splice plate (4) on the other side of the monorail joint as shown in [Figure 3](#). (**NOTE:** See the orientation of the monorail leg (2) in [Figure 3](#).)

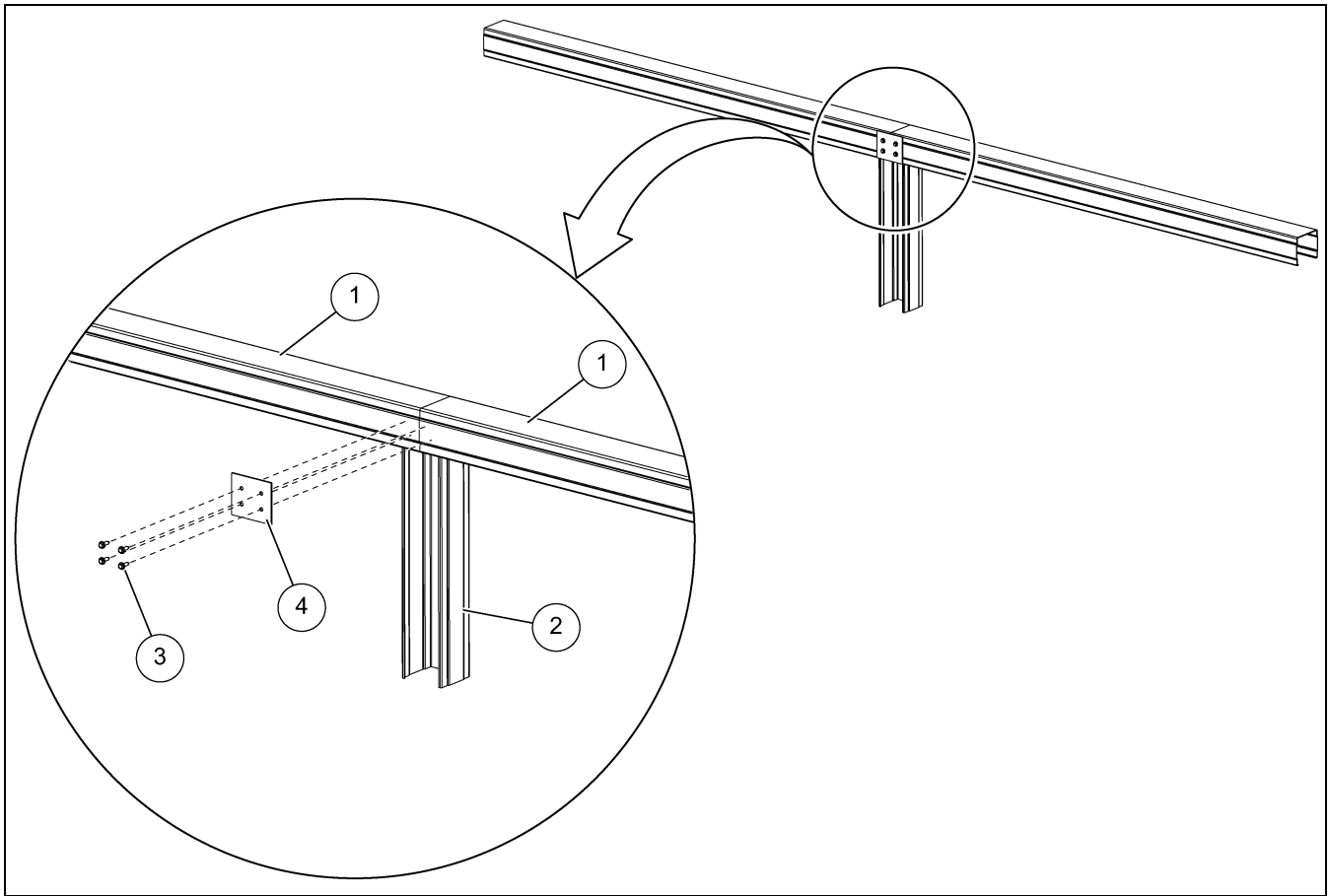

Figure 3 Installing the Monorail Splice Plate

Ref #	Part #	Description
1	FL-403-1	Rails for Monorail Per Foot
2*	FL-403-X	Monorail Leg
3	S-280	Screw, SDS #10-16 x 5/8" HWH ZN
4	FL-7415	Monorail Splice Plate

* **NOTE:** "X" denotes the monorail leg part number extension.