



JS500 15', 18', 21', 24', 27' and 30' Diameter Commercial Hopper Tanks

Installation Manual

PNEG-1070-JS

Date: 02-20-14

GSI GROUP



PNEG-1070-JS

All information, illustrations, photos and specifications in this manual are based on the latest information available at the time of publication. The right is reserved to make changes at any time without notice.

Contents

Chapter 1 Introduction	5
Chapter 2 Safety	6
Safety Guidelines	6
General Safety Statement	7
Safety Instructions	8
Safety Sign-Off Sheet	10
Proper Storage of Grain Bin/Silo Materials Prior to Construction	11
Chapter 3 Decals	12
Chapter 4 Foundation	16
12' Diameter Commercial Hopper Tank Foundation up to 12 Rings	16
12' Diameter Commercial Hopper Tank Foundation for 13-17 Rings	17
15' Diameter Commercial Hopper Tank Foundation up to 12 Rings	18
15' Diameter Commercial Hopper Tank Foundation for 13-17 Rings	19
18' Diameter Commercial Hopper Tank Foundation up to 12 Rings	20
18' Diameter Commercial Hopper Tank Foundation for 13-19 Rings	21
21' Diameter Commercial Hopper Tank Foundation up to 12 Rings	22
21' Diameter Commercial Hopper Tank Foundation for 13-19 Rings	23
24' Diameter Commercial Hopper Tank Foundation up to 12 Rings	24
24' Diameter Commercial Hopper Tank Foundation for 13-19 Rings	25
27' Diameter Commercial Hopper Tank Foundation up to 12 Rings	26
27' Diameter Commercial Hopper Tank Foundation for 13-19 Rings	27
30' Diameter Commercial Hopper Tank Foundation up to 12 Rings	28
30' Diameter Commercial Hopper Tank Foundation for 13-19 Rings	29
CHT Column Heights	30
Substructure Parts	31
Typical NCHT Column	32
Chapter 5 15'-24' Hopper Assembly	33
Hopper Section Assembly 15'-24' (4.57 m-7.32 m) Diameter Hopper Tanks	33
18'-21' (5.49 m-6.40 m) 60° "X" Bracing Detail	38
Chapter 6 27'-30' Hopper Assembly	39
Hopper Section Assembly 27'-30' (8.23 m-9.14 m) Diameter Hopper Tanks	39
Chapter 7 Sidewall Assembly	43
Sidewall Erection Instructions	43
Decal Sheet Placement	43
Chapter 8 Lifting Jack	44
Lifting Jack Usage	44
Color Code Chart	45
Chapter 9 Hardware	46
Identifying Bolt Grades	46
Hardware Identification Notes	47
2.66" Commercial Tank Bolting Requirements 2 Stiffeners per Sidewall Sheet	51
Caulking Detail	52

Table of Contents

Chapter 10 Stiffeners	53
Commercial Stiffeners for 2.66" Corrugation	54
2.66" Corrugation Commercial Stiffener Splice Details	55
10 Gauge and 11 Gauge Stiffener Bearing Splice	57
5 Gauge, 6 Gauge, 8 Gauge and 9 Gauge Stiffener Bearing Splice	58
Laminated Stiffener Splice 2.66" Corrugation	59
Laminated to Universal Stiffener Splice 2.66" Corrugation	61
Stiffener to Sidewall Connections 3 Post Tanks	62
Non-Laminated Stiffener to Sidewall Detail	63
Laminated Stiffener to Sidewall Detail	64
Universal Stiffener Starting Location 2.66" Reverse Corrugation Outside Stiffener Only	65
Wind Ring Requirements	66
Installing Wind Rings	66
Stiffener Shim Plate Detail (Use when Necessary)	69
Chapter 11 Flashing Instructions (Optional)	70
Chapter 12 Doors	72
Access Door Weldment Assembly Hardware Package (PLS-41985)	72
Chapter 13 Aeration	73
Aeration Package (Optional)	73
Chapter 14 Ladders	77
Ladder Support Detail	77
Chapter 15 Hoisting	79
Hoist Instructions	79
Chapter 16 Warranty	83

READ THIS MANUAL carefully to learn how to properly use and install equipment. Failure to do so could result in personal injury or equipment damage.

INSPECT the shipment immediately upon arrival. The customer is responsible for ensuring that all quantities are correct. The customer should report and note any damage or shortage on the bill of lading to justify their claim to the transport company.

THIS MANUAL SHOULD BE CONSIDERED a permanent part of your equipment and should be easily accessible when needed.

This warranty provides you the assurance that the company will back its products when defects appear within the warranty period. In some circumstances, the company also provides field improvements, often without charge to the customer, even if the product is out of warranty. Should the equipment be abused, or modified to change its performance beyond the factory specifications, the warranty will become void and field improvements may be denied.

Safety Guidelines

This manual contains information that is important for you, the owner/operator, to know and understand. This information relates to protecting **personal safety** and **preventing equipment problems**. It is the responsibility of the owner/operator to inform anyone operating or working in the area of this equipment of these safety guidelines. To help you recognize this information, we use the symbols that are defined below. Please read the manual and pay attention to these sections. Failure to read this manual and its safety instructions is a misuse of the equipment and may lead to serious injury or death.



This is the safety alert symbol. It is used to alert you to potential personal injury hazards. Obey all safety messages that follow this symbol to avoid possible injury or death.



DANGER indicates a hazardous situation which, if not avoided, will result in death or serious injury.



WARNING indicates a hazardous situation which, if not avoided, could result in death or serious injury.



CAUTION, used with the safety alert symbol, indicates a hazardous situation which, if not avoided, could result in minor or moderate injury.



NOTICE is used to address practices not related to personal injury.

General Safety Statement

Our foremost concern is your safety and the safety of others associated with grain handling equipment. This manual is to help you understand safe operating procedures and some problems that may be encountered by the operator and other personnel.

As owner and/or operator, you are responsible to know what requirements, hazards, and precautions exist and inform all personnel associated with the equipment or in the area. Safety precautions may be required from the personnel. Avoid any alterations to the equipment, which may produce a very dangerous situation, where **SERIOUS INJURY** or **DEATH** may occur.

You should consider the location of the bin site relative to power line locations or electrical transmission equipment. Contact your local power company to review your installation plan or for information concerning required equipment clearance. Clearance of portable equipment that may be taken to the bin site should also be reviewed and considered. Any electrical control equipment in contact with the bin should be properly grounded and installed in accordance with National Electric Code provisions and other local or national codes.

This product is intended for the use of grain storage only. Any other use is a misuse of the product.



This product has sharp edges, which may cause serious injury. To avoid injury, handle sharp edges with caution and always use proper protective clothing and equipment.

Sidewall bundles or sheets must be stored in a safe manner. The safest method of storing sidewall bundles is laying horizontally with the arch of the sheet upward, like a dome. Sidewall sheets stored on edge must be secured so that they cannot fall over and cause injury. Use care when handling and moving sidewall bundles.

Personnel operating or working around equipment should read this manual. This manual must be delivered with equipment to its owner. Failure to read this manual and its safety instructions is a misuse of the equipment.

2. Safety

Safety Instructions

Our foremost concern is your safety and the safety of others associated with this equipment. We want to keep you as a customer. This manual is to help you understand safe operating procedures and some problems that may be encountered by the operator and other personnel.

As owner and/or operator, it is your responsibility to know what requirements, hazards, and precautions exist, and to inform all personnel associated with the equipment or in the area. Safety precautions may be required from the personnel. Avoid any alterations to the equipment. Such alterations may produce a very dangerous situation where **SERIOUS INJURY** or **DEATH** may occur.

This equipment shall be installed in accordance with the current installation codes and applicable regulations, which should be carefully followed in all cases. Authorities having jurisdiction should be consulted before installations are made.

Follow Safety Instructions

Carefully read all safety messages in this manual and safety signs on your machine. Keep signs in good condition. Replace missing or damaged safety signs. Be sure new equipment components and repair parts include the current safety signs. Replacement safety signs are available from the manufacturer.

Learn how to operate the machine and how to use controls properly. Do not let anyone operate without instruction.

Keep your machinery in proper working condition. Unauthorized modifications to the machine may impair the function and/or safety and affect machine life.

If you do not understand any part of this manual or need assistance, contact your dealer.

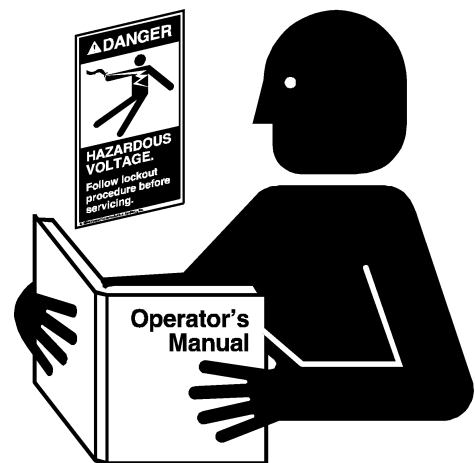

Read and Understand Manual

Practice Safe Maintenance

Understand service procedures before doing work. Keep area clean and dry.

Never lubricate, service, or adjust machine while it is in operation. Keep hands, feet, and clothing away from rotating parts.

Keep all parts in good condition and properly installed. Fix damage immediately. Replace worn or broken parts. Remove any built-up grease, oil, and debris.



Maintain Equipment and Work Area

Prepare for Emergencies

Be prepared if fire starts.

Keep a first aid kit and fire extinguisher handy.

Keep emergency numbers for doctors, ambulance service, hospital, and fire department near your telephone.

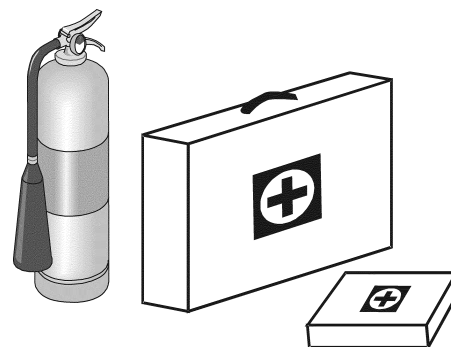

Keep Emergency Equipment Quickly Accessible

Wear Protective Clothing

Wear close-fitting clothing and safety equipment appropriate to the job.

Remove all jewelry.

Tie long hair up and back.

Wear safety glasses at all times to protect eyes from debris.

Wear gloves to protect your hands from sharp edges on plastic or steel parts.

Wear steel-toed boots to help protect your feet from falling debris. Tuck in any loose or dangling shoestrings.

A respirator may be needed to prevent breathing potentially toxic fumes and dust.

Wear a hard hat to help protect your head.

Wear appropriate fall protection equipment when working at elevations greater than six feet (6').

Eye Protection

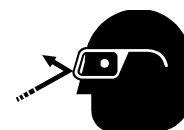

Gloves



Steel-Toed Boots



Respirator



Hard Hat



Fall Protection



Proper Storage of Grain Bin/Silo Materials Prior to Construction

Wet storage stain (rust) will develop when closely packed bundles of galvanized material, such as sidewall and roof sheets, have moisture present. Inspect roof and sidewall bundles on arrival for any moisture. If moisture is present, it must not be allowed to remain between the sheets. Separate the sheets or panels immediately and wipe them down. Spray with a light oil or diesel fuel.

If possible, sidewall bundles, roof sheets and other closely packed galvanized materials should be stored in a dry, climate controlled building. If outdoor storage is unavoidable, the materials should be stored so that they are raised above the ground and vegetation. Any stacking and spacing materials should not be corrosive or wet. Be sure to protect materials from the weather, but permit air movement around the bundles if possible.

Storing roof bundles and sidewall sheets at a slight incline can also help minimize the presence of moisture. Storing the bundles with the center of the dome up (like an arch) is one option for minimizing moisture during storage. Sidewall bundles can also be stored on edge but must be secured so that they do not fall over and cause injury.

If “white rust” or “wet storage stain” occurs, contact the manufacturer immediately about ways to minimize the adverse effect upon the galvanized coating.

3. Decals

The manufacturer does not warrant any roof damage caused by excessive vacuum or internal pressure from fans or other air moving systems. Adequate ventilation and/or “makeup air” devices should be provided for all powered air handling systems. The manufacturer does not recommend the use of downward flow systems (suction). Severe roof damage can result from any blockage of air passages. Running fans during high humidity/cold weather conditions can cause air exhaust or intake ports to freeze.



CAUTION

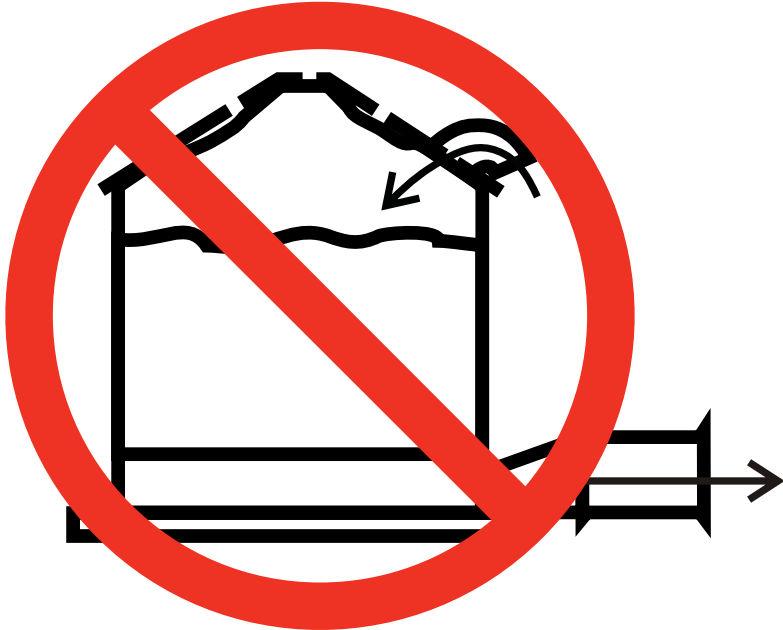

Excessive vacuum (or pressure) may damage roof. Use positive aeration system. Make sure all roof vents are open and unobstructed. Start roof fans when supply fans are started. Do not operate when conditions exist that may cause roof vent icing.

GSI Group, Inc. 217-226-4421DC-969

ATTENTION: The decal shown below should be present on the outside of the door cover of the 2 ring, 24" porthole door cover and roof manway cover. If a decal has been damaged or is missing in any of these locations, contact the manufacturer for a free replacement decal.

GSI Decals

1004 E. Illinois St.
Assumption, IL. 62510
Phone: 1-217-226-4421

 <h1 style="margin: 0;">DANGER</h1>		
 <p>Rotating flighting will kill or dismember.</p>	 <p>Flowing material will trap and suffocate.</p>	 <p>Crusted material will collapse and suffocate.</p>
<h2 style="margin: 0;">Keep clear of all augers. DO NOT ENTER this bin!</h2>		
<p>If you must enter the bin:</p> <ol style="list-style-type: none"> 1. Shut off and lock out all power. 2. Use a safety harness and safety line. 3. Station another person outside the bin. 4. Avoid the center of the bin. 5. Wear proper breathing equipment or respirator. 		
<h2 style="margin: 0;">Failure to heed these warnings will result in serious injury or death.</h2>		
GSI GROUP, INC. 217-226-4421		DC-GBC-1A

3. Decals

ATTENTION: The decal shown below should be present on the outside of the door cover of the 2 ring, 24" porthole door cover and roof manway cover. If a decal has been damaged or is missing in any of these locations, contact the manufacturer for a free replacement decal.

GSI Decals

1004 E. Illinois St.
Assumption, IL. 62510
Phone: 1-217-226-4421



WARNING

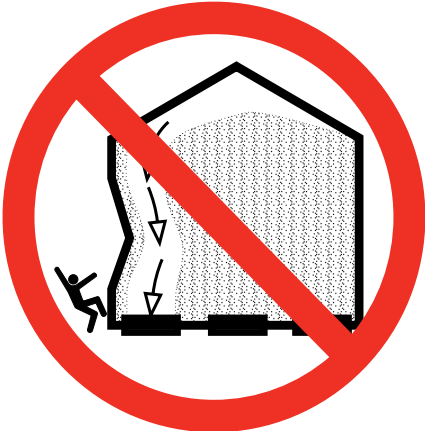



UNLOADING INSTRUCTIONS:

1. Use **CENTER FLOOR OUTLET ONLY** until **NO** grain remains above this outlet.
2. Side floor outlets to be used **ONLY** when above condition is satisfied.
3. Lock all side floor outlets to avoid accidental premature use.
4. See manufacturers instructions for proper use of factory supplied sidedraw (wall) discharge systems.

Failure to heed these warnings
could result in serious injury, death,
structural damage or collapse of tank.

GSI GROUP, INC. 217-226-4421**DC-GBC-2A**



**Sidewall and stiffener gauge sheets
are not included in this manual.
They may be obtained by calling
GSI if they are not attached to the
front of this manual.**

4. Foundation

12' Diameter Commercial Hopper Tank Foundation up to 12 Rings

Materials required:
 12 Cubic yards of concrete
 800' #4 bar
 300' #5 bar
 150 Square feet 6 x 6 - 6/6 wire mesh

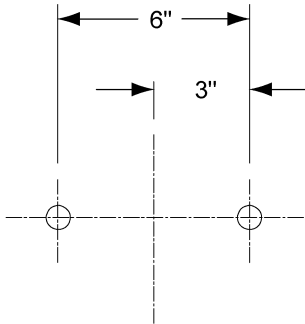

Detail A

4' - 8-1/16"
 Chord distance
 eight (8) spaces

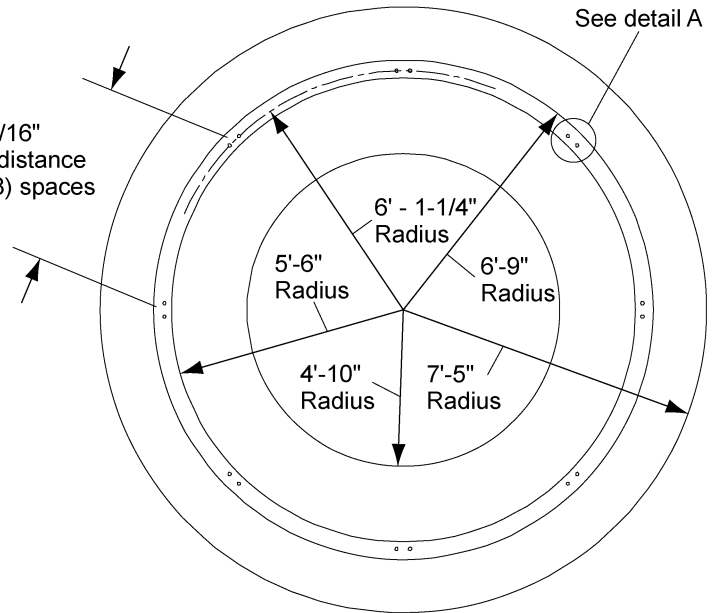

NOTES:

1. The foundation design is based on a minimum allowable soil bearing capacity of 3000 PSF. Bearing capacity of the soils should be determined by geotechnical investigation and be of uniform bearing capacity.
2. The foundation site must be free of vegetation and debris and well drained.
3. The foundation must be founded below the frost line, or placed on non-expansive frost free fill.
4. All material used for backfill inside the ring wall should be clean, well graded, crushed rock or a sand gravel mixture. Backfill should be placed in 6" lifts, 95% compaction.
5. All reinforcement must meet the requirements of ASTM A615 grade 60 deformed bars.
6. Lap all circumferential bars 35 bar diameters and stagger all laps in plans 3'-0". Estimates for material do not include end laps.
7. Concrete must have a minimum compressive strength of 3000 PSI at 28 days, 6%-8% air entrainment, 4" slump.
8. Codes: UBC 97, ACI 318-95
9. Interior top slab may be crowned 2" to provide water drainage away from foundation. Crowning the slab will reduce the clearance under the discharge.

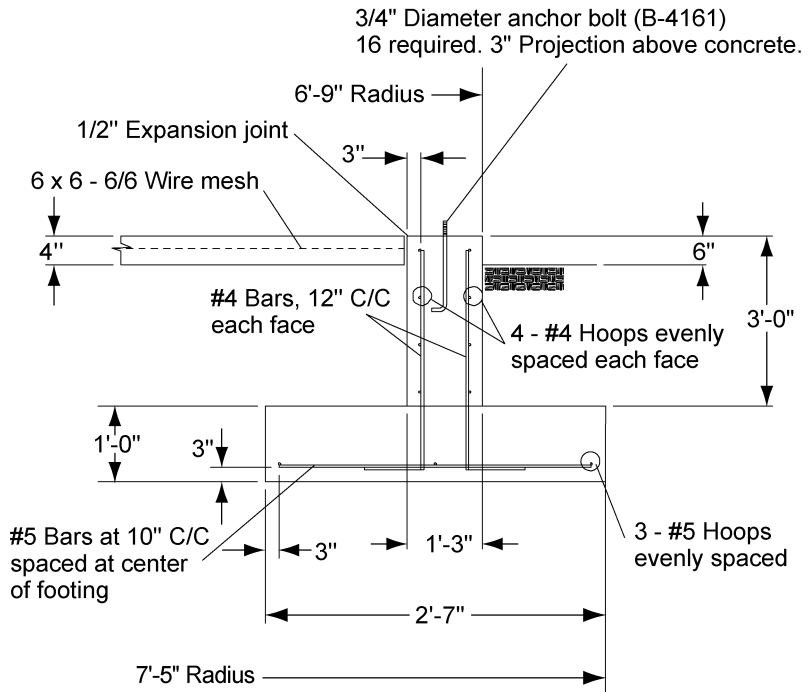

Footing detail
 (NOTE: Not to scale)

Figure 4A

12' Diameter Commercial Hopper Tank Foundation for 13-17 Rings

Materials required:
 14 Cubic yards of concrete
 800' #4 Bar
 400' #5 Bar
 150 Square feet 6 x 6 - 6/6 wire mesh

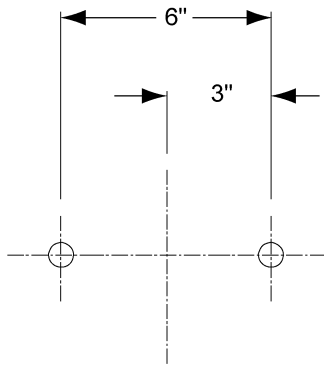

Detail A

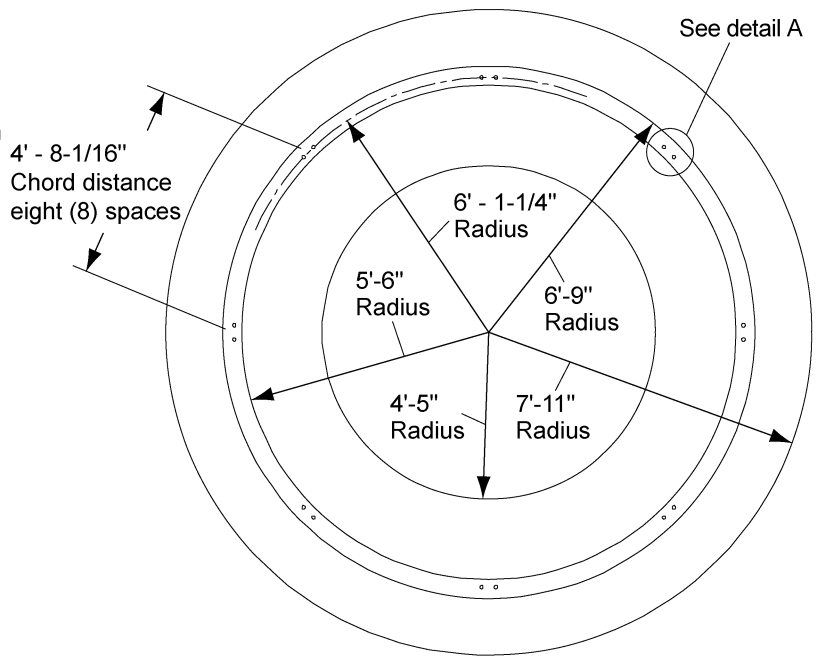

NOTES:

1. The foundation design is based on a minimum allowable soil bearing capacity of 3000 PSF. Bearing capacity of the soils should be determined by geotechnical investigation and be of uniform bearing capacity.
2. The foundation site must be free of vegetation and debris and well drained.
3. The foundation must be founded below the frost line, or placed on non-expansive frost free fill.
4. All material used for backfill inside the ring wall should be clean, well graded, crushed rock or a sand gravel mixture. Backfill should be placed in 6" lifts, 95% compaction.
5. All reinforcement must meet the requirements of ASTM A615 grade 60 deformed bars.
6. Lap all circumferential bars 35 bar diameters and stagger all laps in plans 3'-0". Estimates for material do not include end laps.
7. Concrete must have a minimum compressive strength of 3000 PSI at 28 days, 6%-8% air entrainment, 4" slump.
8. Codes: UBC 97, ACI 318-95
9. Interior top slab may be crowned 2" to provide water drainage away from foundation. Crowning the slab will reduce the clearance under the discharge.

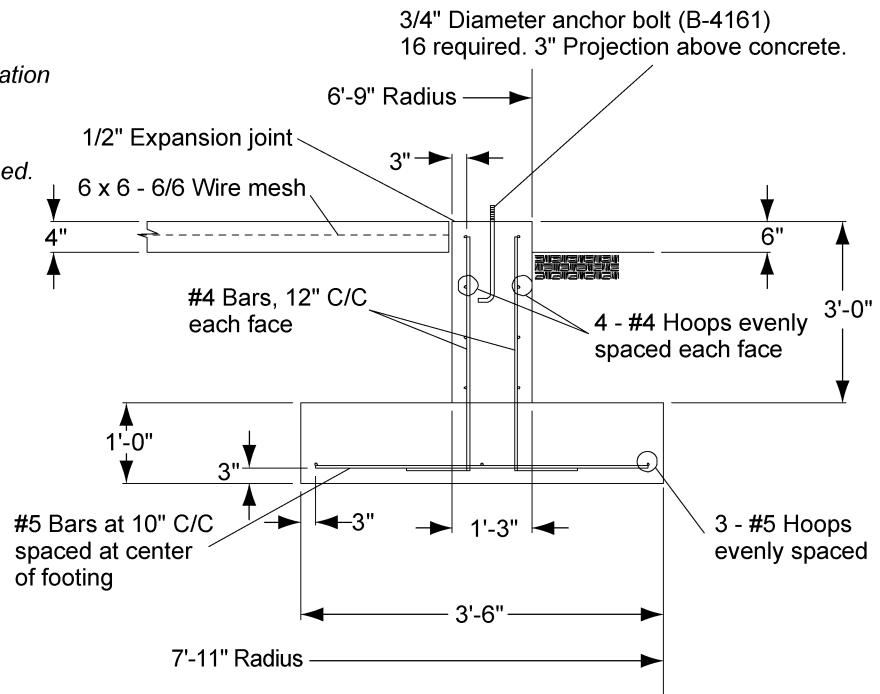

Footing detail

(NOTE: Not to scale)

Figure 4B

4. Foundation

15' Diameter Commercial Hopper Tank Foundation up to 12 Rings

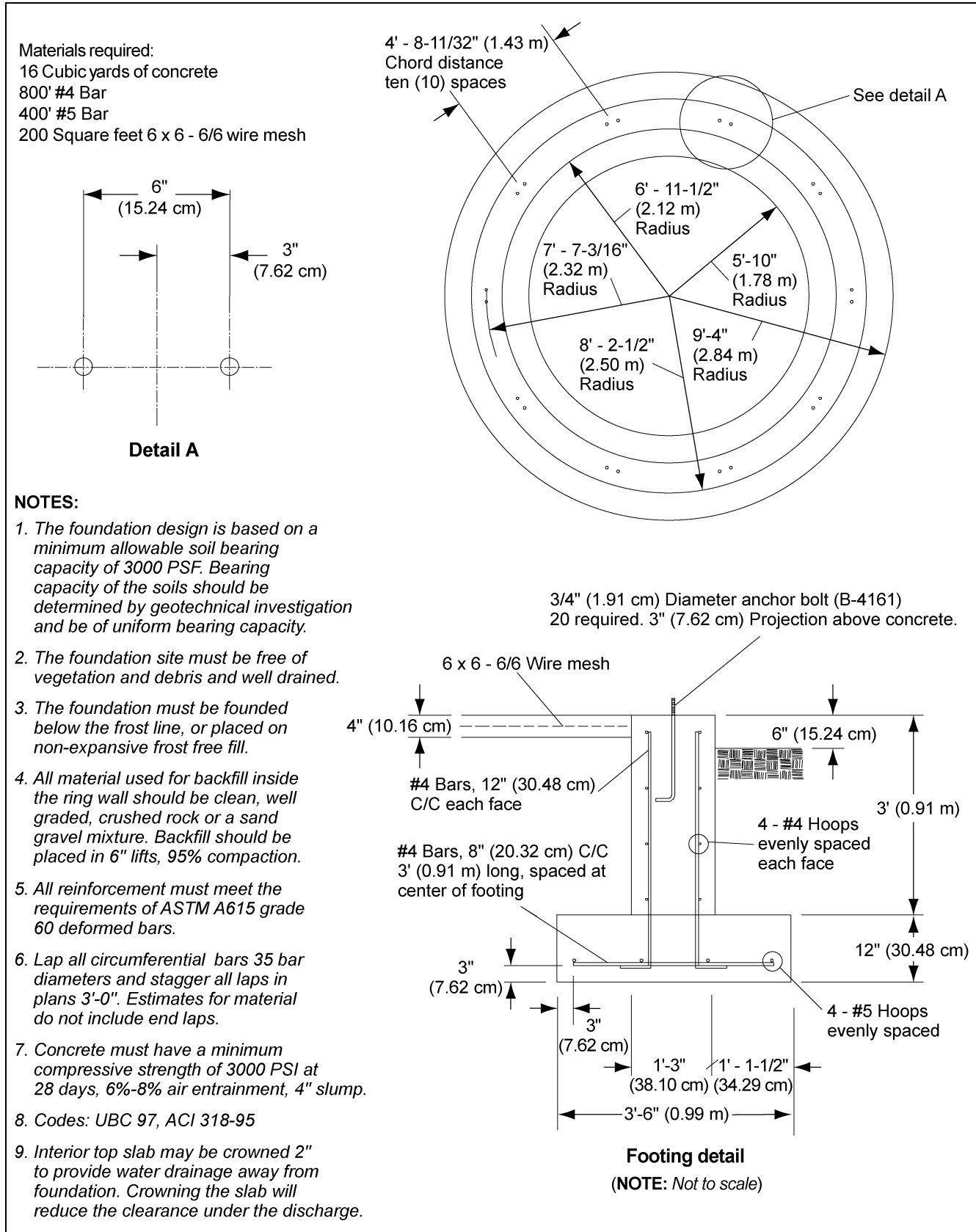

Figure 4C

15' Diameter Commercial Hopper Tank Foundation for 13-17 Rings

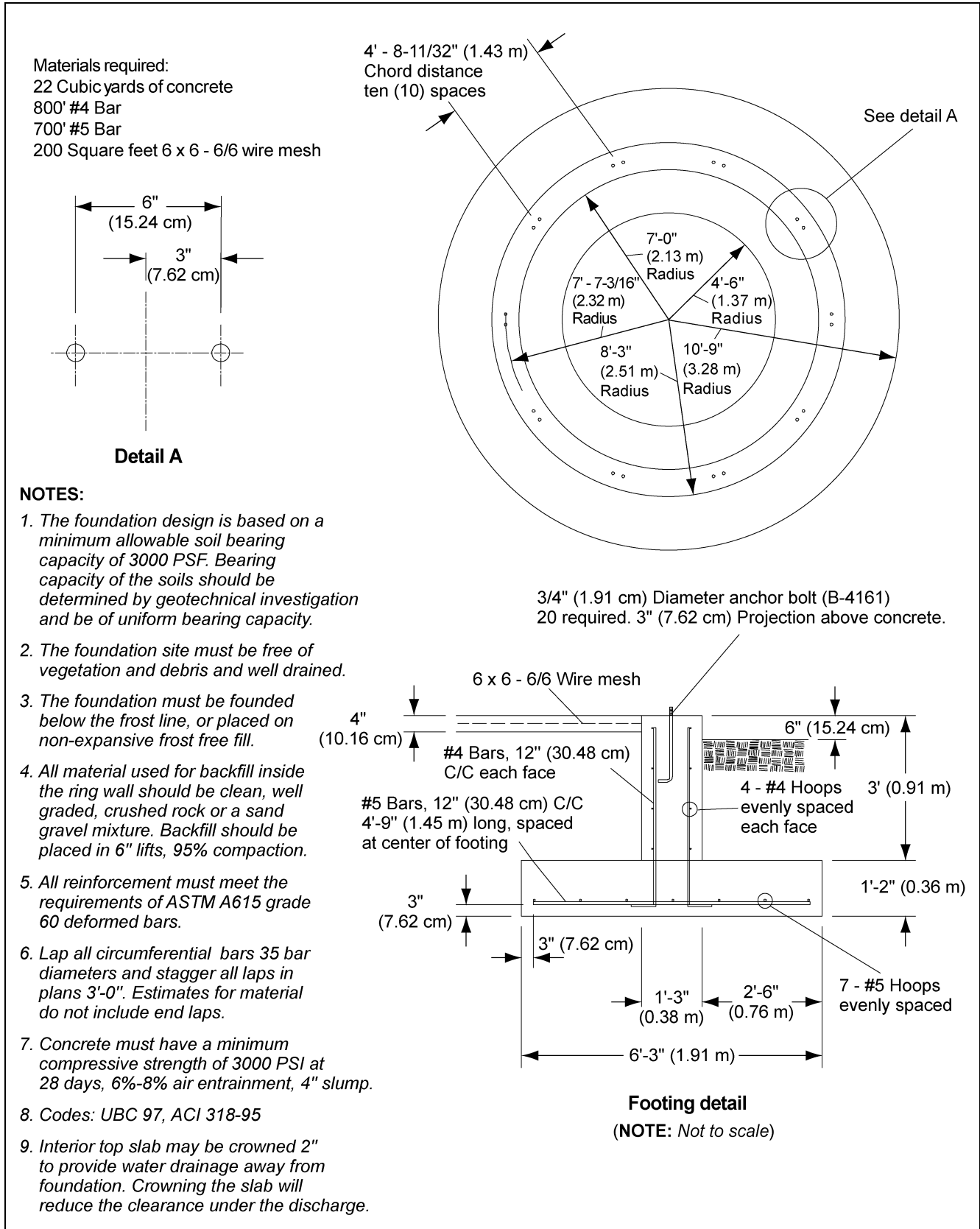

Figure 4D

4. Foundation

18' Diameter Commercial Hopper Tank Foundation up to 12 Rings

Materials required:

20 Cubic yards of concrete

1700' #4 bar

350 Square feet 6 x 6 - 6/6 wire mesh

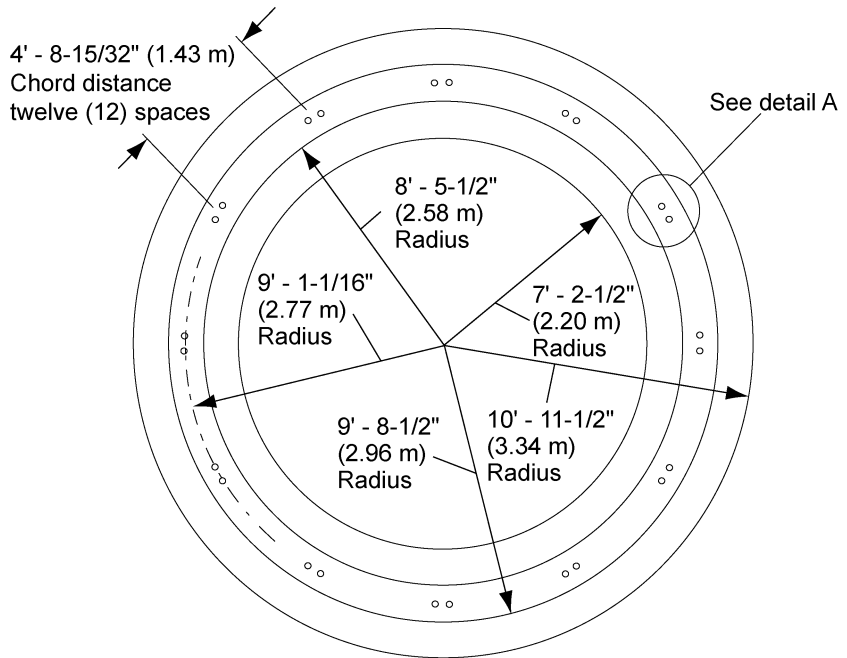
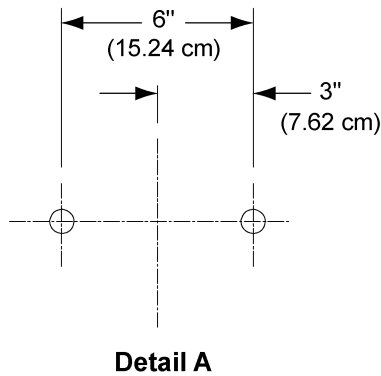

NOTES:

1. The foundation design is based on a minimum allowable soil bearing capacity of 3000 PSF. Bearing capacity of the soils should be determined by geotechnical investigation and be of uniform bearing capacity.
2. The foundation site must be free of vegetation and debris and well drained.
3. The foundation must be founded below the frost line, or placed on non-expansive frost free fill.
4. All material used for backfill inside the ring wall should be clean, well graded, crushed rock or a sand gravel mixture. Backfill should be placed in 6" lifts, 95% compaction.
5. All reinforcement must meet the requirements of ASTM A615 grade 60 deformed bars.
6. Lap all circumferential bars 35 bar diameters and stagger all laps in plans 3'-0". Estimates for material do not include end laps.
7. Concrete must have a minimum compressive strength of 3000 PSI at 28 days, 6%-8% air entrainment, 4" slump.
8. Codes: UBC 97, ACI 318-95
9. Interior top slab may be crowned 2" to provide water drainage away from foundation. Crowning the slab will reduce the clearance under the discharge.

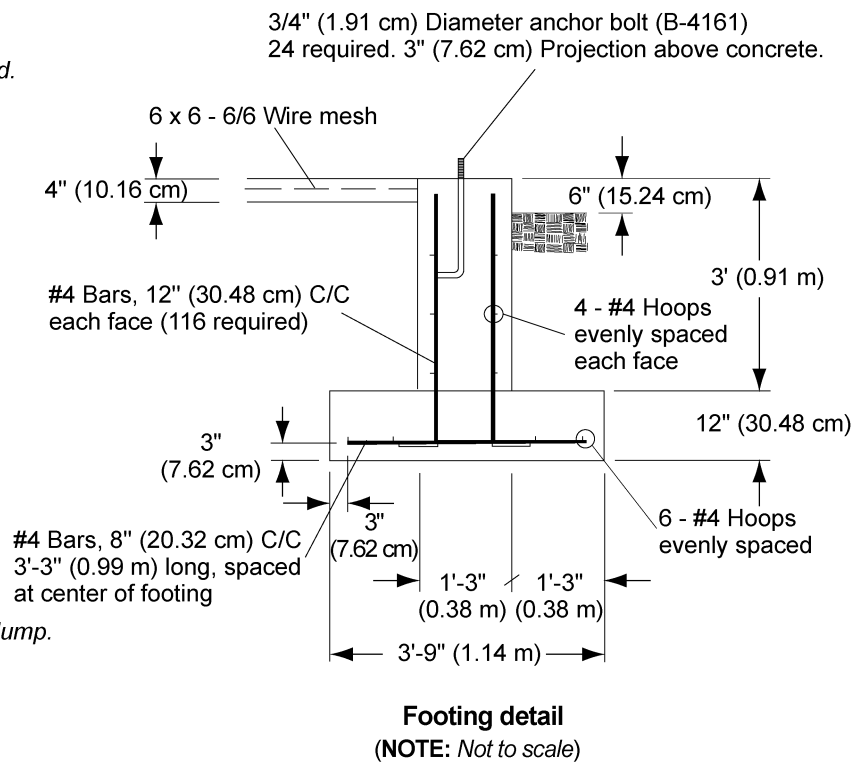

Figure 4E

18' Diameter Commercial Hopper Tank Foundation for 13-19 Rings

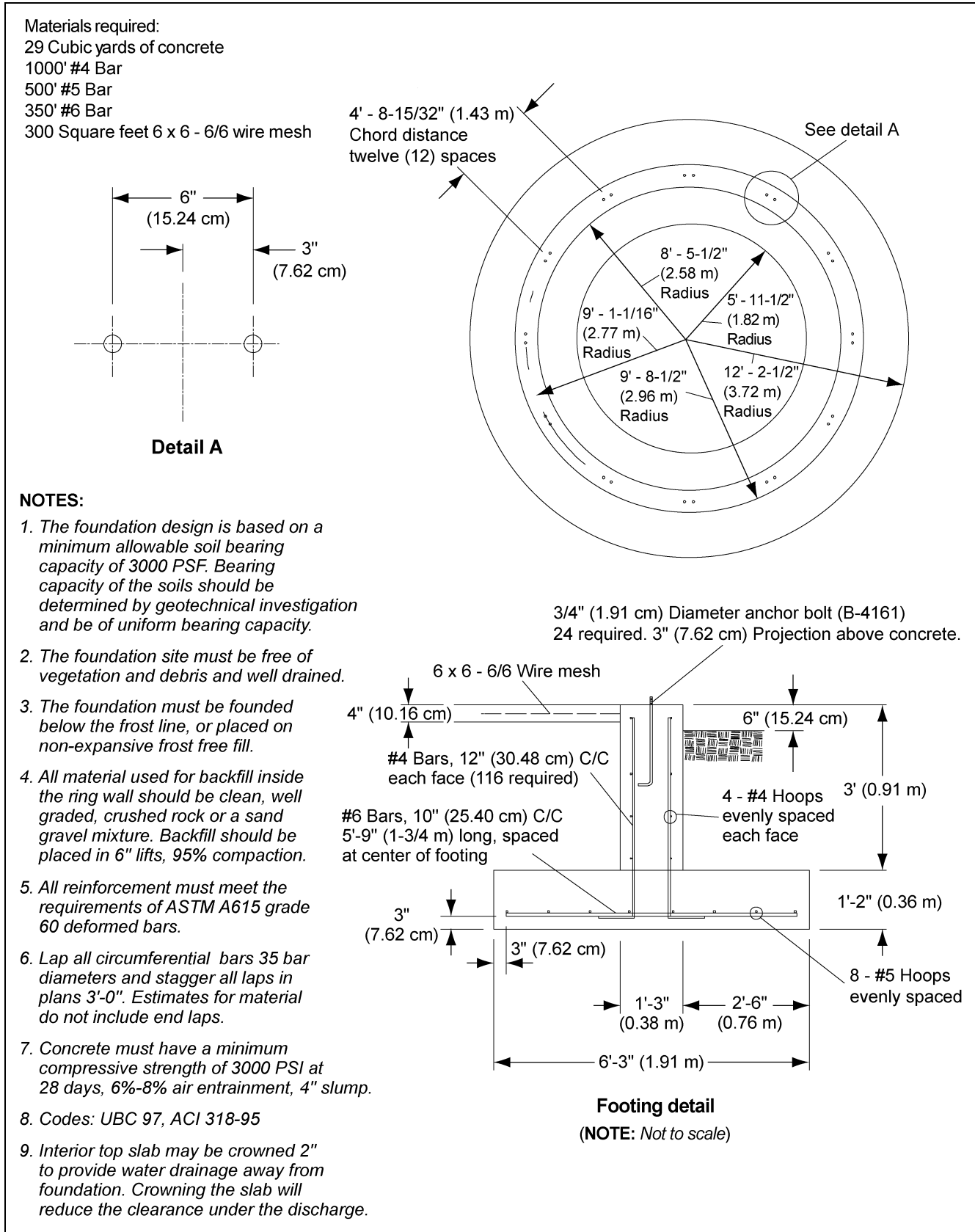

Figure 4F

4. Foundation

21' Diameter Commercial Hopper Tank Foundation up to 12 Rings

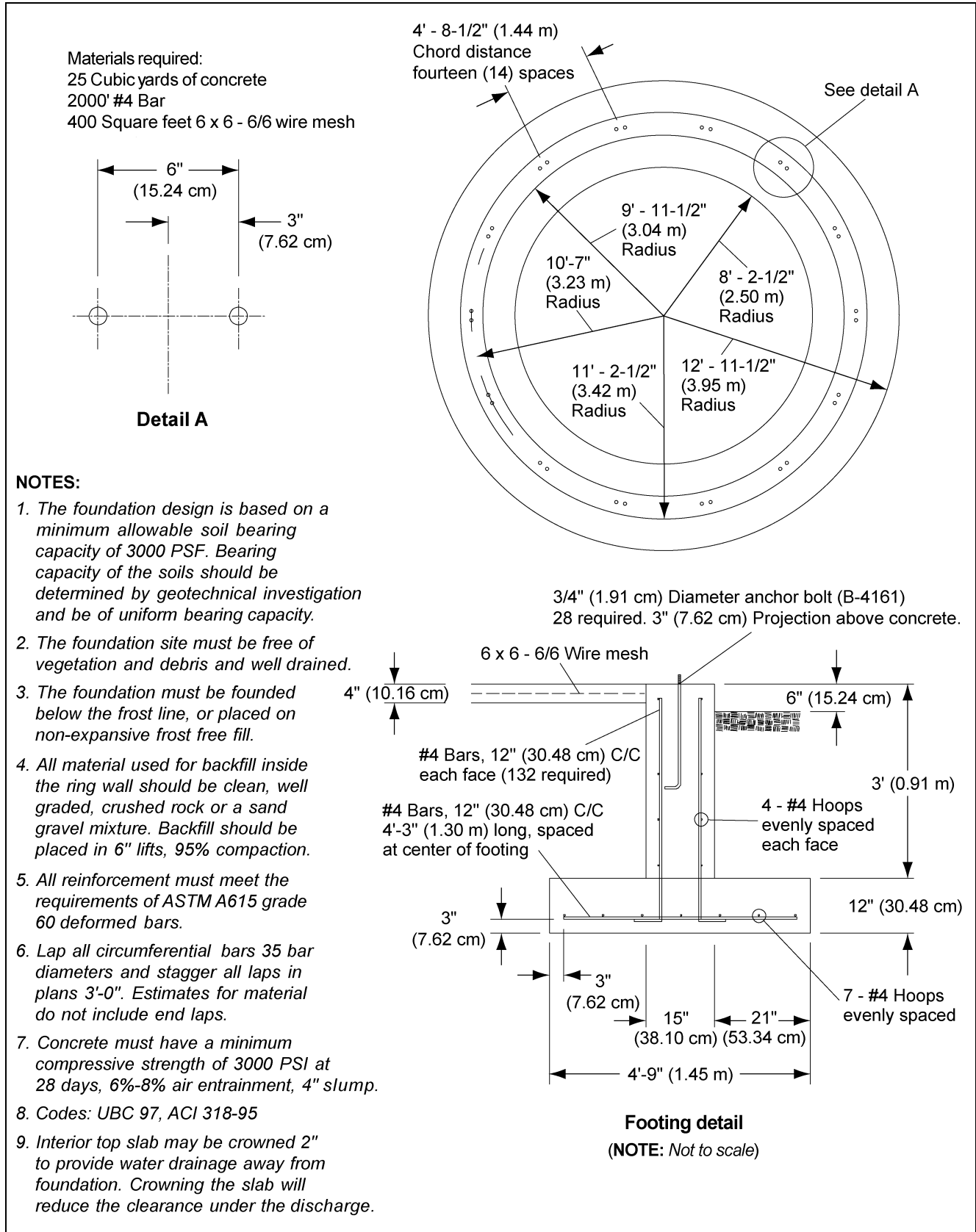

Figure 4G

21' Diameter Commercial Hopper Tank Foundation for 13-19 Rings

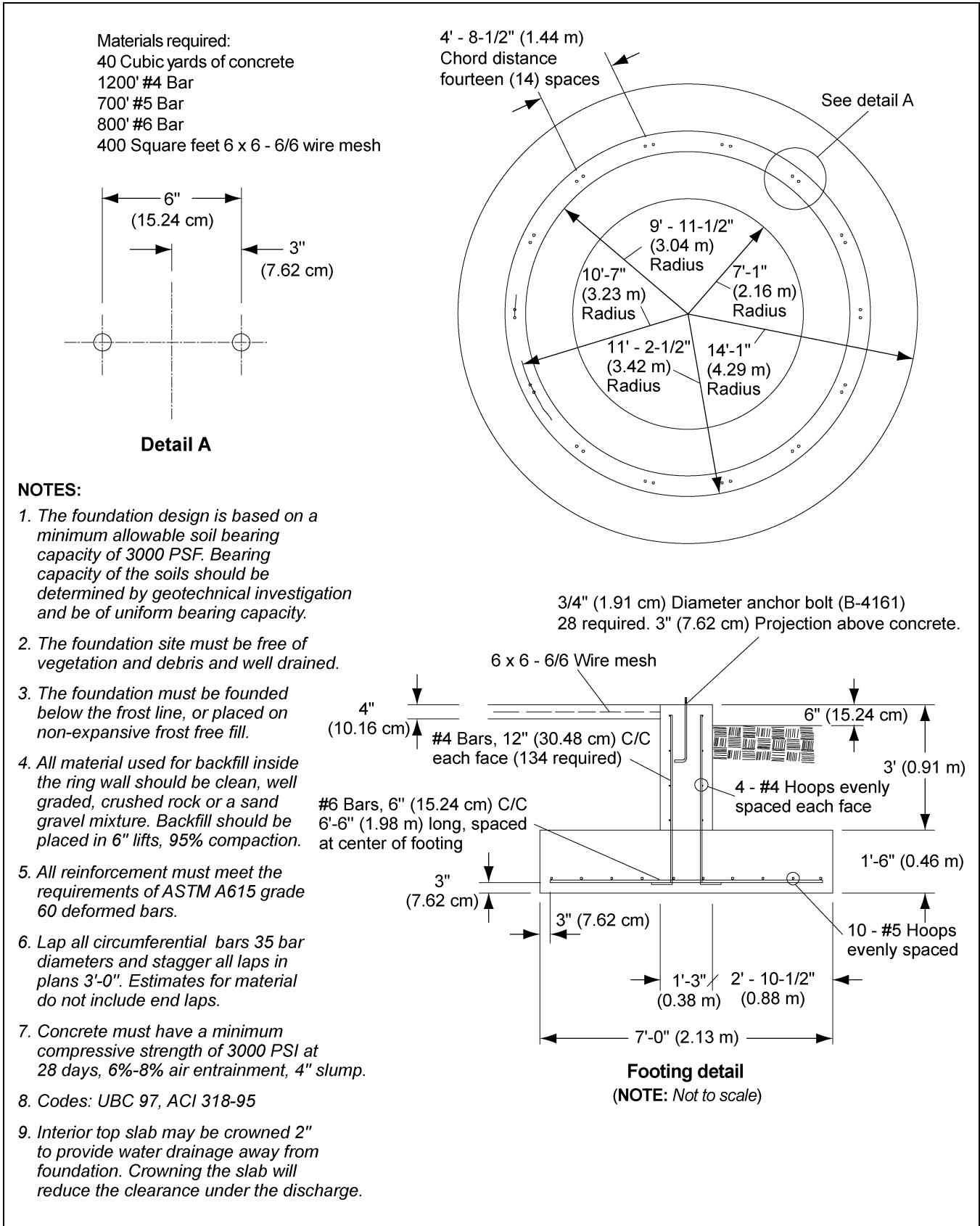

Figure 4H

4. Foundation

24' Diameter Commercial Hopper Tank Foundation up to 12 Rings

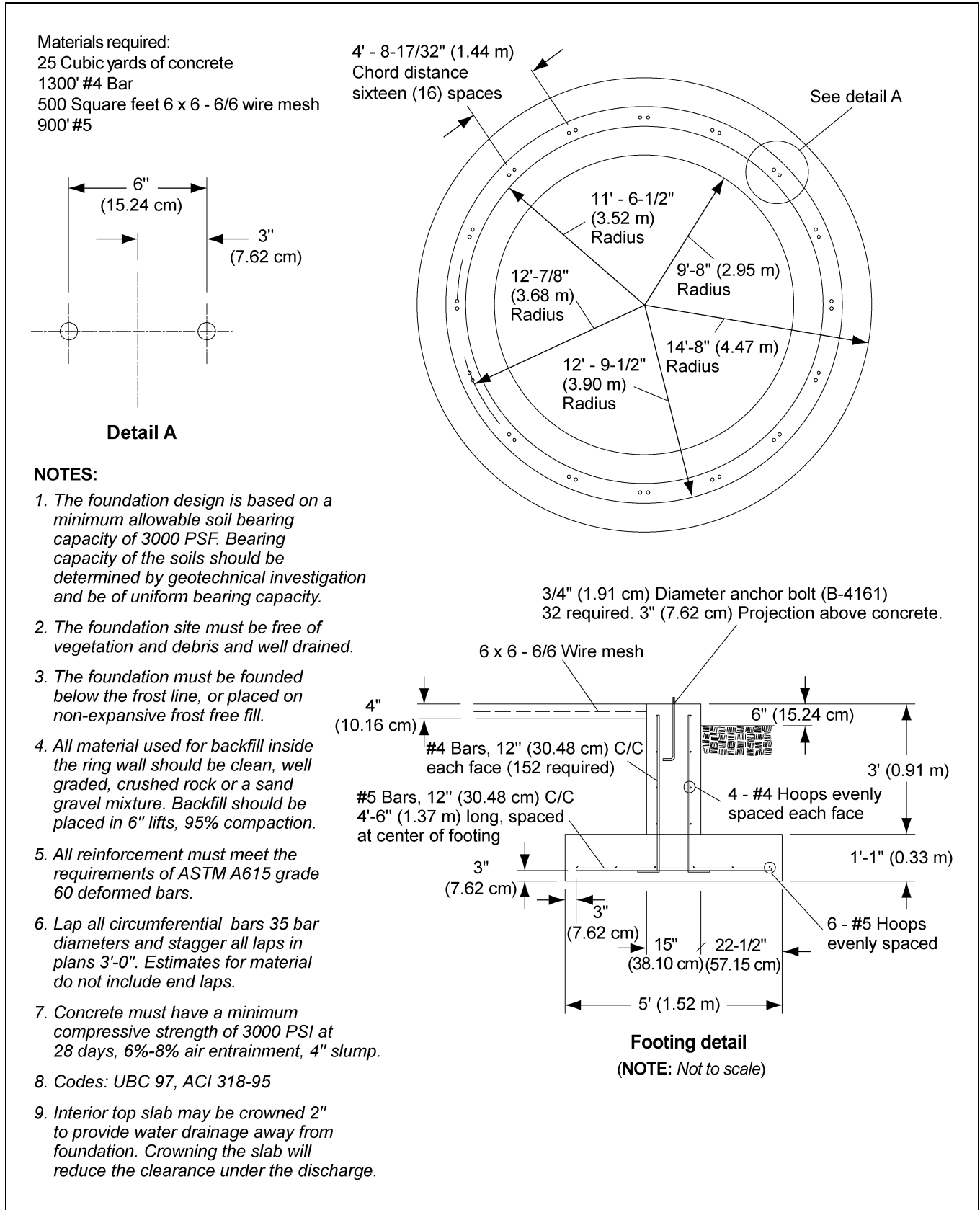
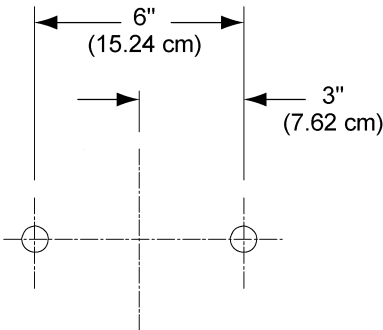

Figure 41

24' Diameter Commercial Hopper Tank Foundation for 13-19 Rings

Materials required:
 40 Cubic yards of concrete
 1200' #4 Bar
 700' #5 Bar
 900' #6 Bar
 500 Square feet 6 x 6 - 6/6 wire mesh



Detail A

4' - 8-17/32" (1.44 m)
 Chord distance
 sixteen (16) spaces

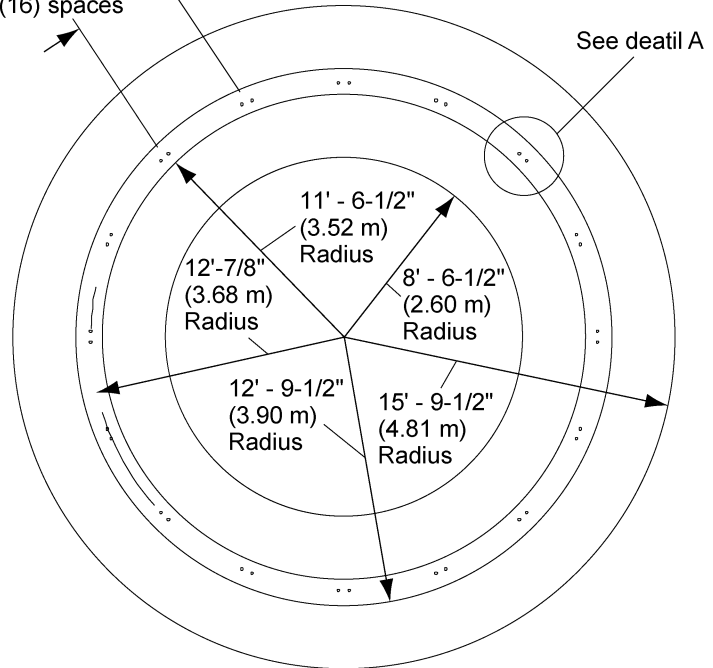

NOTES:

1. The foundation design is based on a minimum allowable soil bearing capacity of 3000 PSF. Bearing capacity of the soils should be determined by geotechnical investigation and be of uniform bearing capacity.
2. The foundation site must be free of vegetation and debris and well drained.
3. The foundation must be founded below the frost line, or placed on non-expansive frost free fill.
4. All material used for backfill inside the ring wall should be clean, well graded, crushed rock or a sand gravel mixture. Backfill should be placed in 6" lifts, 95% compaction.
5. All reinforcement must meet the requirements of ASTM A615 grade 60 deformed bars.
6. Lap all circumferential bars 35 bar diameters and stagger all laps in plans 3'-0". Estimates for material do not include end laps.
7. Concrete must have a minimum compressive strength of 3000 PSI at 28 days, 6%-8% air entrainment, 4" slump.
8. Codes: UBC 97, ACI 318-95
9. Interior top slab may be crowned 2" to provide water drainage away from foundation. Crowning the slab will reduce the clearance under the discharge.

3/4" (1.91 cm) Diameter anchor bolt (B-4161)
 32 required. 3" (7.62 cm) Projection above concrete.

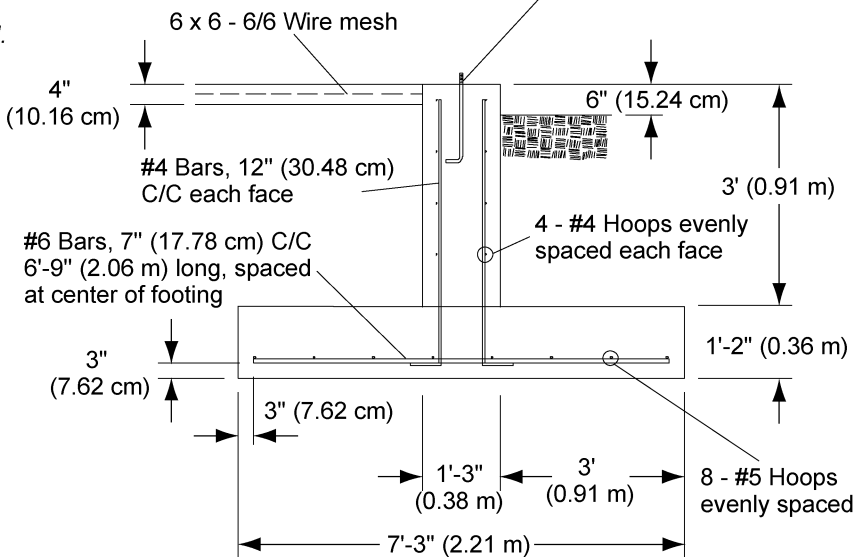

Footing detail
 (NOTE: Not to scale)

Figure 4J

4. Foundation

27' Diameter Commercial Hopper Tank Foundation up to 12 Rings

Materials required:

- 36 Cubic yards of concrete
- 1600' #4 Bar
- 450' #5 Bar
- 450' #6 Bar
- 700 Square feet 6 x 6 - 6/6 wire mesh

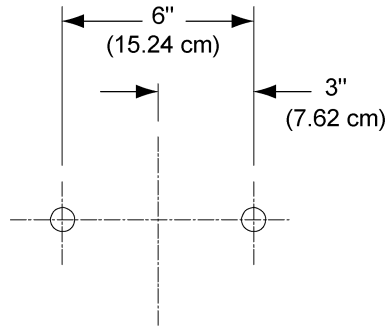

Detail A

4' - 8-17/32" (1.44 m)
Chord distance
eighteen (18) spaces

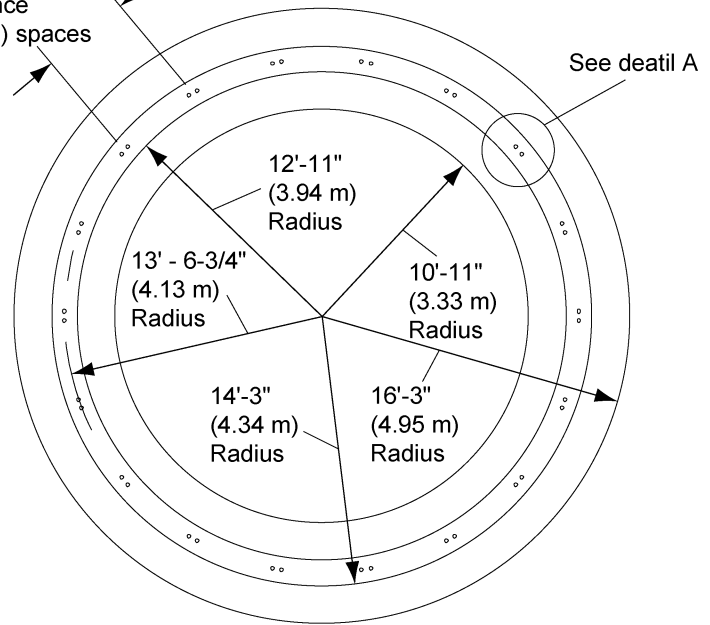

NOTES:

1. The foundation design is based on a minimum allowable soil bearing capacity of 3000 PSF. Bearing capacity of the soils should be determined by geotechnical investigation and be of uniform bearing capacity.
2. The foundation site must be free of vegetation and debris and well drained.
3. The foundation must be founded below the frost line, or placed on non-expansive frost free fill.
4. All material used for backfill inside the ring wall should be clean, well graded, crushed rock or a sand gravel mixture. Backfill should be placed in 6" lifts, 95% compaction.
5. All reinforcement must meet the requirements of ASTM A615 grade 60 deformed bars.
6. Lap all circumferential bars 35 bar diameters and stagger all laps in plans 3'-0". Estimates for material do not include end laps.
7. Concrete must have a minimum compressive strength of 3000 PSI at 28 days, 6%-8% air entrainment, 4" slump.
8. Codes: UBC 97, ACI 318-95
9. Interior top slab may be crowned 2" to provide water drainage away from foundation. Crowning the slab will reduce the clearance under the discharge.

3/4" (1.91 cm) Diameter anchor bolt (B-4161)
36 required. 3" (7.62 cm) Projection above concrete.

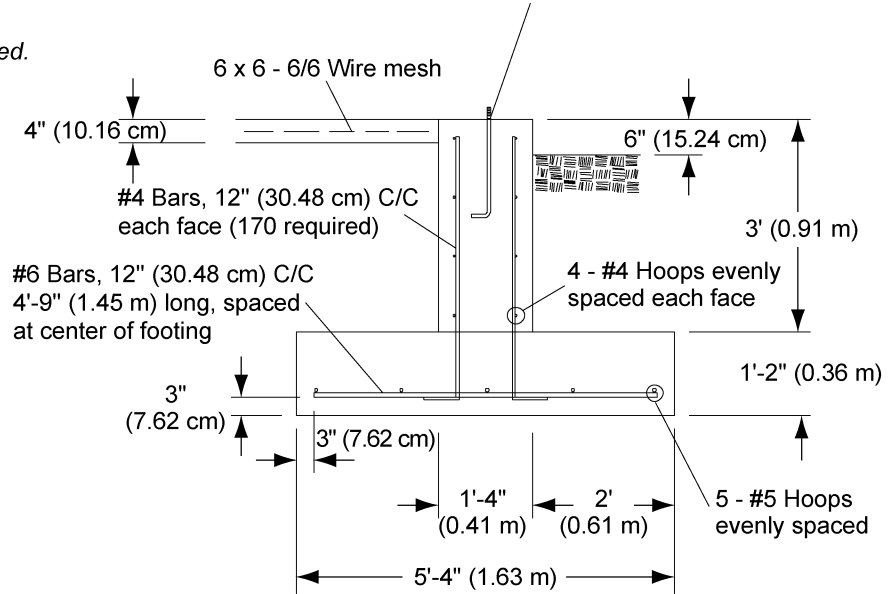

Footing detail
(NOTE: Not to scale)

Figure 4K

27' Diameter Commercial Hopper Tank Foundation for 13-19 Rings

Materials required:
 58 Cubic yards of concrete
 1600' #4 Bar
 900' #5 Bar
 1400' #6 Bar
 700 Square feet 6 x 6 - 6/6 wire mesh

4' - 8-17/32" (1.44 m)
 Chord distance
 eighteen (18) spaces

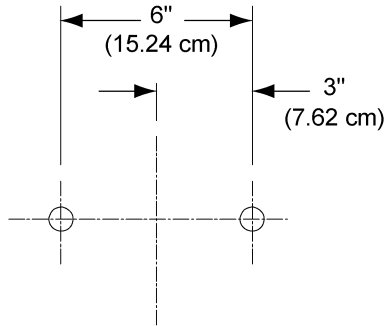

Detail A

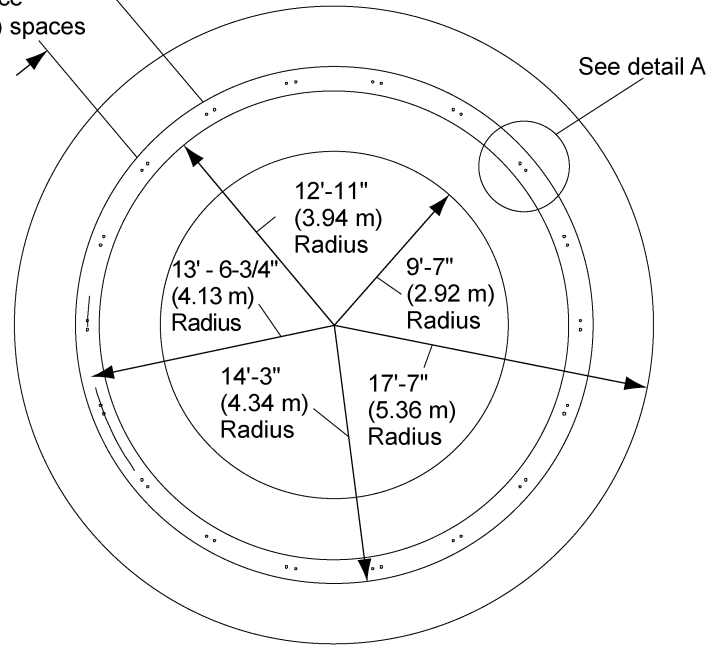

NOTES:

1. The foundation design is based on a minimum allowable soil bearing capacity of 3000 PSF. Bearing capacity of the soils should be determined by geotechnical investigation and be of uniform bearing capacity.
2. The foundation site must be free of vegetation and debris and well drained.
3. The foundation must be founded below the frost line, or placed on non-expansive frost free fill.
4. All material used for backfill inside the ring wall should be clean, well graded, crushed rock or a sand gravel mixture. Backfill should be placed in 6" lifts, 95% compaction.
5. All reinforcement must meet the requirements of ASTM A615 grade 60 deformed bars.
6. Lap all circumferential bars 35 bar diameters and stagger all laps in plans 3'-0". Estimates for material do not include end laps.
7. Concrete must have a minimum compressive strength of 3000 PSI at 28 days, 6%-8% air entrainment, 4" slump.
8. Codes: UBC 97, ACI 318-95
9. Interior top slab may be crowned 2" to provide water drainage away from foundation. Crowning the slab will reduce the clearance under the discharge.

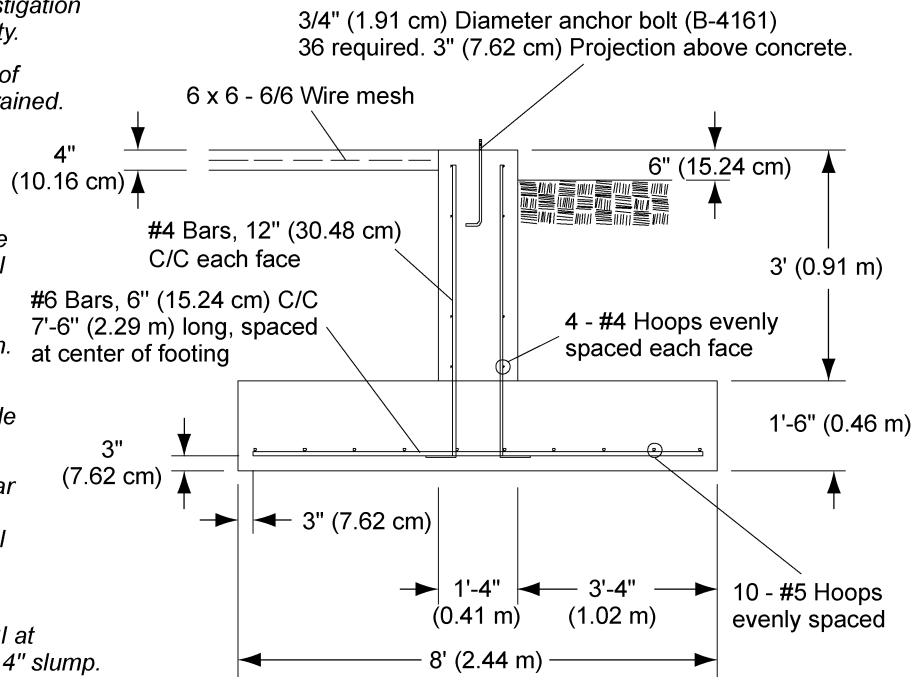

Footing detail
 (NOTE: Not to scale)

Figure 4L

4. Foundation

30' Diameter Commercial Hopper Tank Foundation up to 12 Rings

Materials required:
 44 Cubic yards of concrete
 1700' #4 Bar
 700' #5 Bar
 550' #6 Bar
 850 Square feet 6 x 6 - 6/6 wire mesh

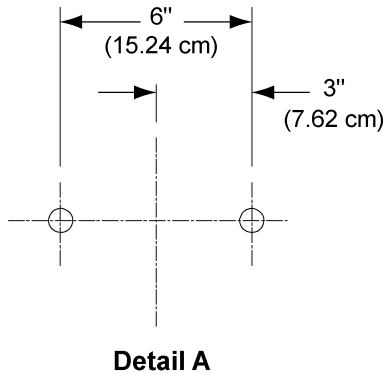

4' - 8-9/16" (1.44 m)
 Chord distance
 twenty (20) spaces

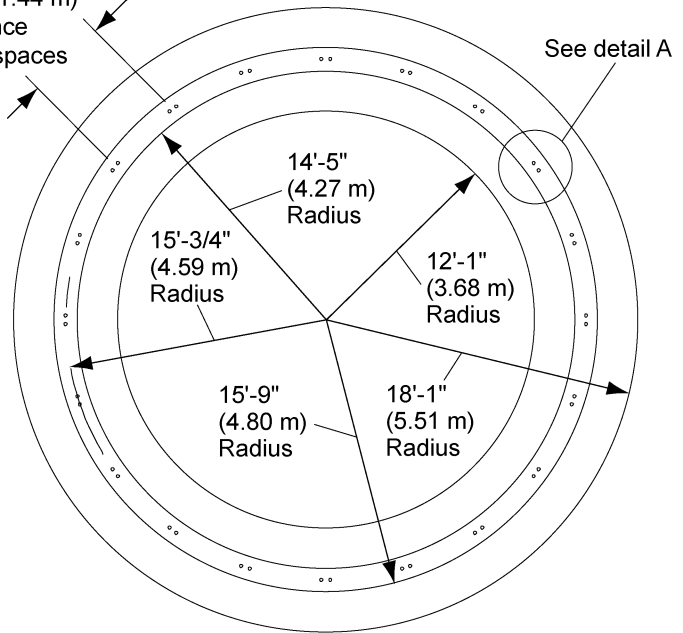

NOTES:

1. The foundation design is based on a minimum allowable soil bearing capacity of 3000 PSF. Bearing capacity of the soils should be determined by geotechnical investigation and be of uniform bearing capacity.
2. The foundation site must be free of vegetation and debris and well drained.
3. The foundation must be founded below the frost line, or placed on non-expansive frost free fill.
4. All material used for backfill inside the ring wall should be clean, well graded, crushed rock or a sand gravel mixture. Backfill should be placed in 6" lifts, 95% compaction.
5. All reinforcement must meet the requirements of ASTM A615 grade 60 deformed bars.
6. Lap all circumferential bars 35 bar diameters and stagger all laps in plans 3'-0". Estimates for material do not include end laps.
7. Concrete must have a minimum compressive strength of 3000 PSI at 28 days, 6%-8% air entrainment, 4" slump.
8. Codes: UBC 97, ACI 318-95
9. Interior top slab may be crowned 2" to provide water drainage away from foundation. Crowning the slab will reduce the clearance under the discharge.

3/4" (1.91 cm) Diameter anchor bolt (B-4161)
 40 required. 3" (7.62 cm) Projection above concrete.

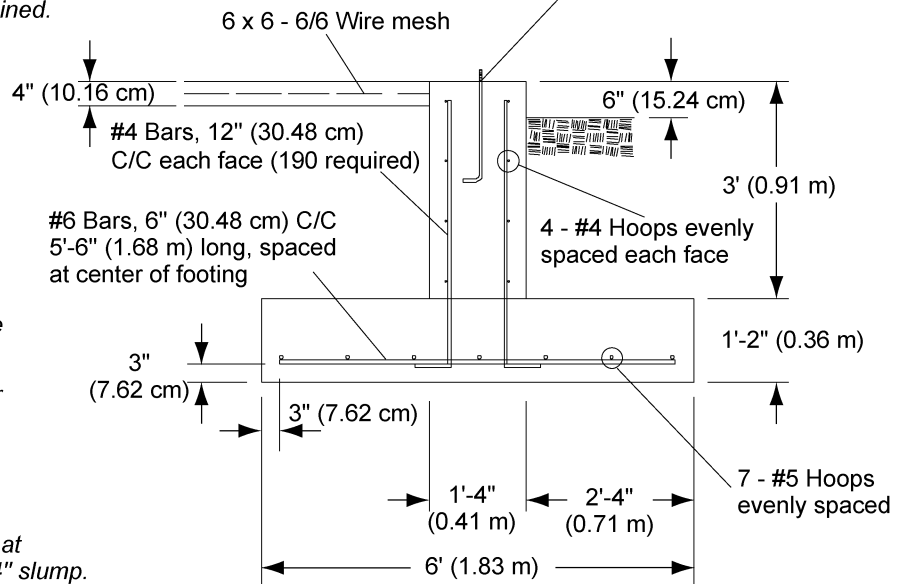

Footing detail
 (NOTE: Not to scale)

Figure 4M

30' Diameter Commercial Hopper Tank Foundation for 13-19 Rings

Materials required:
 80 Cubic yards of concrete
 1600' #4 Bar
 1600' #5 Bar
 2400' #6 Bar
 700 Square feet 6 x 6 - 6/6 wire mesh

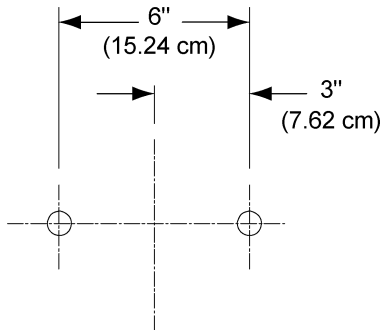

Detail A

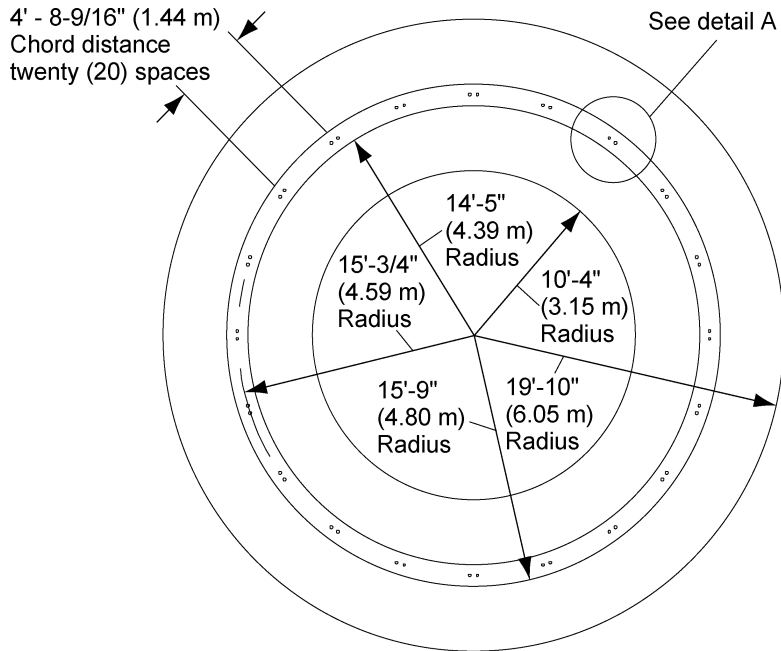

NOTES:

1. The foundation design is based on a minimum allowable soil bearing capacity of 3000 PSF. Bearing capacity of the soils should be determined by geotechnical investigation and be of uniform bearing capacity.
2. The foundation site must be free of vegetation and debris and well drained.
3. The foundation must be founded below the frost line, or placed on non-expansive frost free fill.
4. All material used for backfill inside the ring wall should be clean, well graded, crushed rock or a sand gravel mixture. Backfill should be placed in 6" lifts, 95% compaction.
5. All reinforcement must meet the requirements of ASTM A615 grade 60 deformed bars.
6. Lap all circumferential bars 35 bar diameters and stagger all laps in plans 3'-0". Estimates for material do not include end laps.
7. Concrete must have a minimum compressive strength of 3000 PSI at 28 days, 6%-8% air entrainment, 4" slump.
8. Codes: UBC 97, ACI 318-95
9. Interior top slab may be crowned 2" to provide water drainage away from foundation. Crowning the slab will reduce the clearance under the discharge.

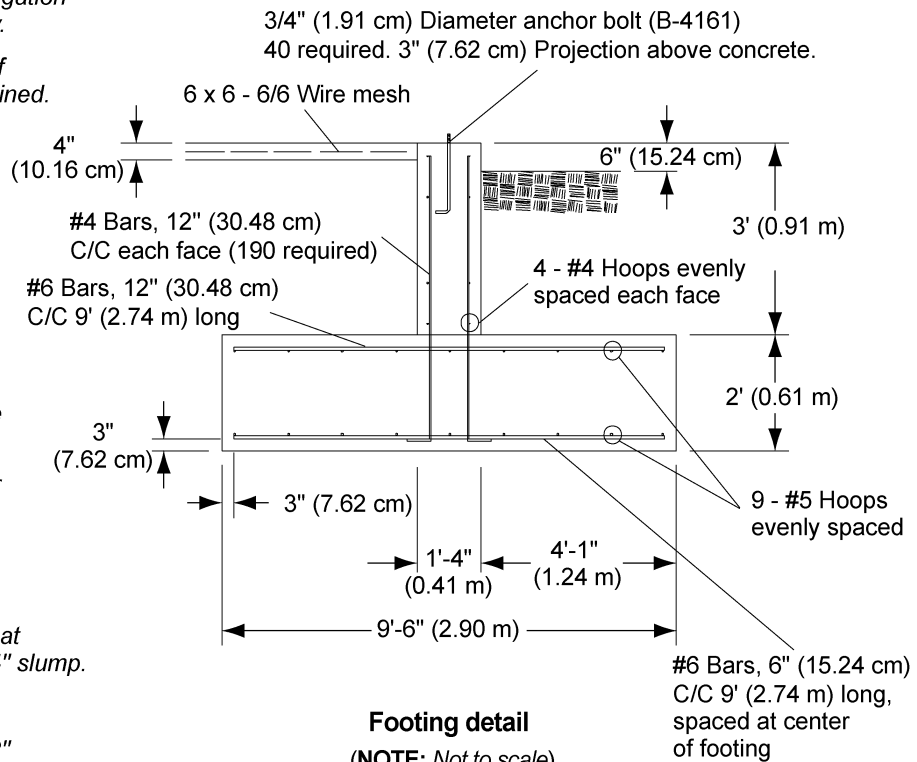

Footing detail
 (NOTE: Not to scale)

Figure 4N

CHT Column Heights

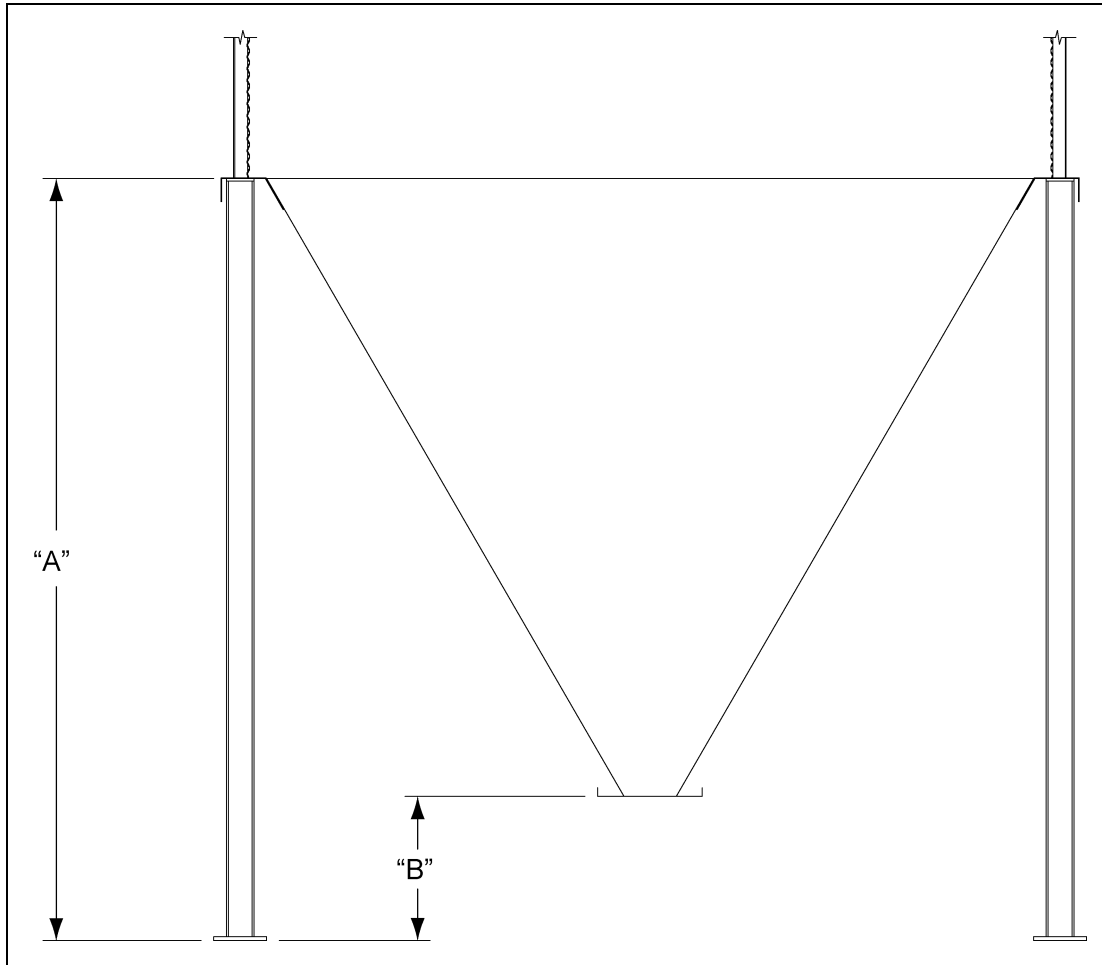

Figure 40 Standard Commercial Hopper Tank Column Heights

Tank Diameter	Hopper Slope	"A" Dimension		"B" Dimension	
		Feet	Meters	Inches	Millimeters
12'	45	7' - 11-7/8"	2.44	32	813
15'	45	9' - 5-3/8"	2.88	32	813
15'	60	14' - 4-5/8"	4.39	32	813
18'	45	11'-1/8"	3.36	32	813
18'	60	16' - 11-5/8"	5.17	32	813
21'	45	12'-5"	3.79	32	813
21'	60	19' - 6-3/4"	5.96	32	813
24'	45	13' - 10-7/8"	4.24	32	813
27'	40	12' - 2-7/8"	3.73	28	711
27'	45	15' - 4-3/8"	4.68	32	813
30'	40	13' - 4-7/8"	4.09	28	711
30'	45	16' - 10-1/4"	5.14	32	813

Substructure Parts

Part List for Substructure for Commercial Hopper Tanks

Tank Size	15' - 45°	15' - 60°	18' - 45°	18' - 60°
Color Code	Yellow	Black and Yellow	Red	Black and Red
Column Weldment	CHT-1201 (10)	SCHT-1444 (10)	CHT-1184 (12)	SCHT-1475 (12)
Compress Angle Weldment	CHT-1202 (10)	SCHT-1438 (10)	CHT-1209 (12)	SCHT-1986 (12)
Hopper Collar Weldment	CHT-1135 (1)	SCHT-1434 (1)	CHT-1136 (1)	SCHT-1466 (1)
"X" Bracing Rod	CHT-1203 (20)	SCHT-1432 (40)	CHT-1175 (24)	SCHT-1473 (48)
"X" Bracing Rod Size	3/4" x 100"	7/8" x 166"	3/4" x 116"	3/4" x 107"
Top R.H. Hopper Panel	CHT-1390 (10)	SCHT-1941 (10)	CHT-1375 (12)	SCHT-1987 (12)
Top L.H. Hopper Panel	CHT-1391 (10)	SCHT-1940 (10)	CHT-1374 (12)	SCHT-1988 (12)
Bottom R.H. Hopper Panel	N/A	N/A	N/A	N/A
Bottom L.H. Hopper Panel	N/A	N/A	N/A	N/A
Compression Channel	N/A	N/A	N/A	N/A
Support Hardware	CHT-1392 (1)	SCHT-1949 (1)	CHT-1373 (1)	SCHT-1896 (1)

Tank Size	21' - 45°	21' - 60°	24' - 45°	27' - 40°	30' - 40°
Color Code	Blue	Black and Blue	Green	Orange	Purple
Column Weldment	CHT-1159 (14)	SCHT-1484 (14)	CHT-1118 (16)	CHT-1017 (18)	CHT-1037 (20)
Compress Angle Weldment	CHT-1167 (14)	SCHT-1471 (14)	CHT-1119 (16)	CHT-1018 (18)	CHT-1038 (20)
Hopper Collar Weldment	CHT-1137 (1)	SCHT-1467 (1)	CHT-1133 (1)	CHT-1056 (1)	CHT-1036 (1)
"X" Bracing Rod	CHT-1144 (28)	SCHT-1481 (56)	CHT-1117 (32)	CHT-1026 (36)	CHT-1045 (40)
"X" Bracing Rod Size	3/4" x 126"	3/4" x 120"	3/4" x 144"	3/4" x 123"	3/4" x 137"
Top R.H. Hopper Panel	CHT-1421 (14)	SCHT-1463 (14)	CHT-1372 (16)	CHT-1479 (18)	CHT-1366 (20)
Top L.H. Hopper Panel	CHT-1420 (14)	SCHT-1462 (14)	CHT-1371 (16)	CHT-1478 (18)	CHT-1365 (20)
Bottom R.H. Hopper Panel	N/A	SCHT-1461 (14)	N/A	CHT-1481 (18)	CHT-1368 (20)
Bottom L.H. Hopper Panel	N/A	SCHT-1460 (14)	N/A	CHT-1480 (18)	CHT-1367 (20)
Compression Channel	N/A	N/A	N/A	CHT-1025	CHT-1052
Support Hardware**	CHT-1422 (1)	SCHT-1485 (1)	CHT-1370 (1)	CHT-1483 (1)	CHT-1369 (1)

****NOTE:** The 3/8" x 1" bin bolts (with sealing washer) for attachment hopper panels to the compression element are included in the sidewall hardware.

Typical NCHT Column

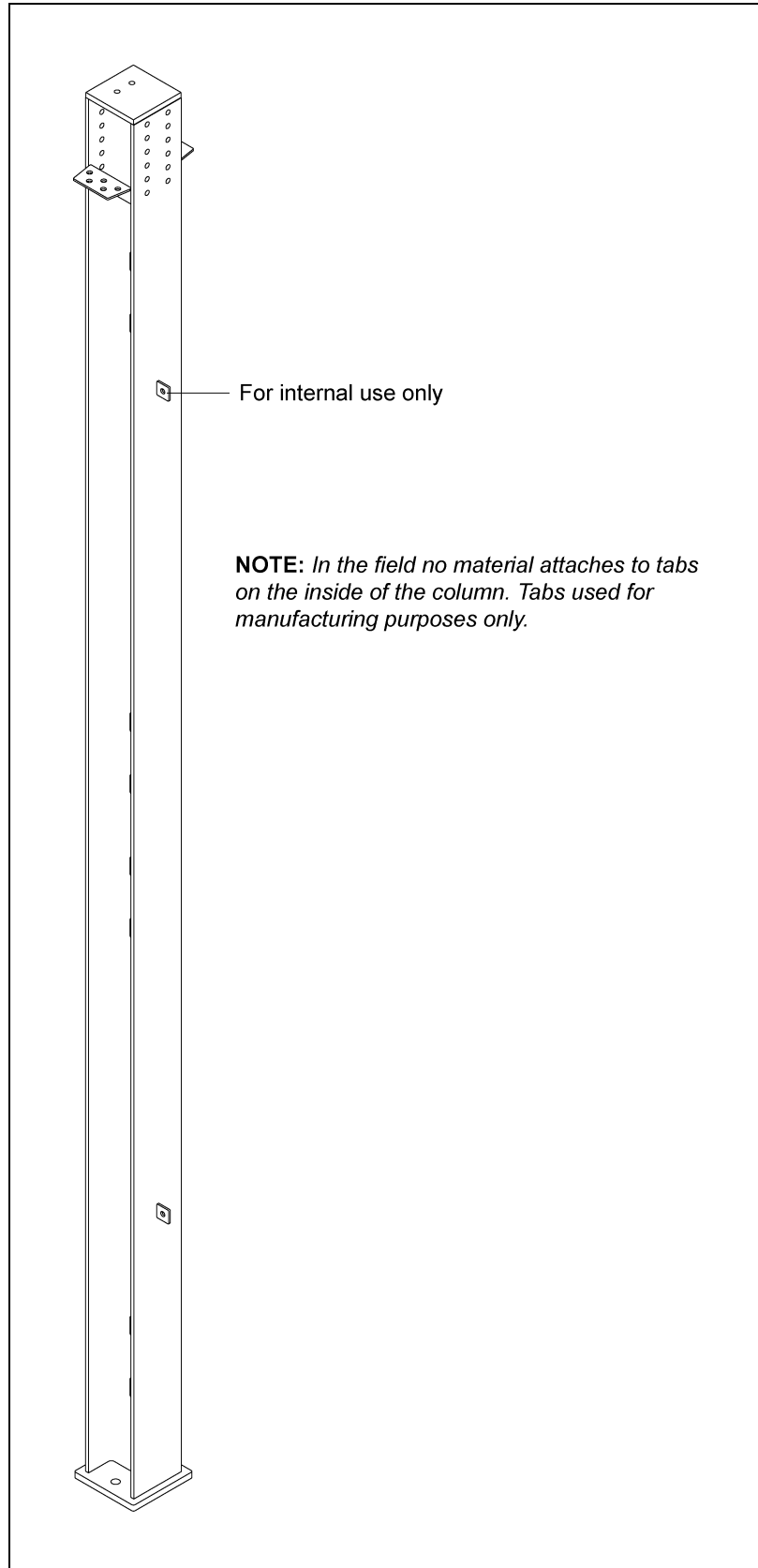

Figure 4P

Hopper Section Assembly 15'-24' (4.57 m-7.32 m) Diameter Hopper Tanks

Before placing the support columns on the anchor bolts, use a transit and surveyor's rod to locate high and low areas in the concrete. To assure level alignment for the support columns, use the proper supplied shim or shims between the concrete and base plate. After leveling is completed, place the support columns over the anchor bolts, with shim plates (B) underneath column. Next place washer (HT-635) over anchor bolts and loosely fasten with nuts and washers (not furnished). Refer to [Figure 5A](#).

NOTE: 15' (4.57 m) Diameter hopper tanks have 10 columns.
 18' (5.49 m) Diameter hopper tanks have 12 columns.
 21' (6.40 m) Diameter hopper tanks have 14 columns.
 24' (7.32 m) Diameter hopper tanks have 16 columns.

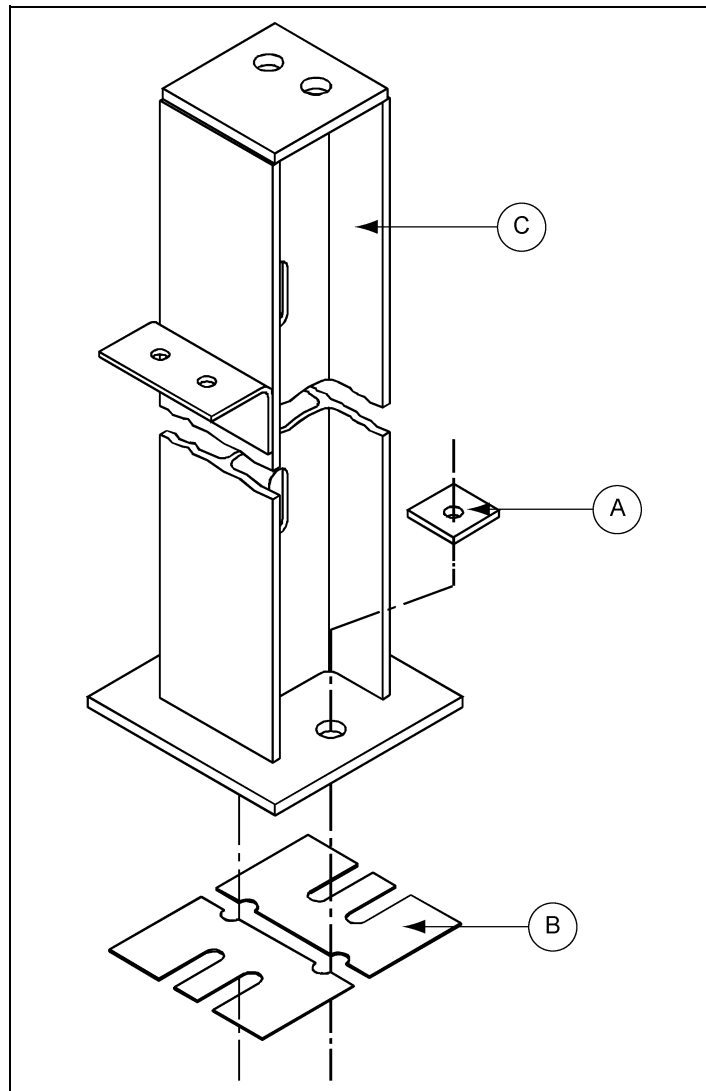

Figure 5A

Ref #	Part #	Description
A	HT-635	Square Washer for 3/4" Anchor Bolt
B	CHT-1160	Shim Plate
C		Column Weldment

5. 15'-24' Hopper Assembly

Hopper Section Assembly 15'-24' (4.57 m-7.32 m) Diameter Hopper Tanks (Continued)

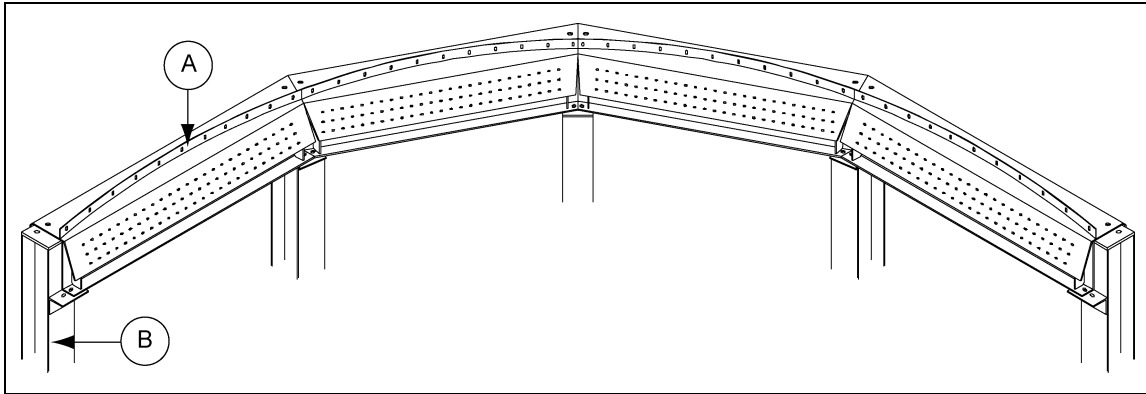

Figure 5B Compression Angle Erection

Ref #	Description
A	Compression Angle Weldment
B	Support Column

Using 5/8"-11 x 1-1/2" bolts (S-4109) and 5/8" nuts (S-4110), fasten the compression angle segments to the support clips (D) on the support columns. A 5/8"-11 x 2-3/4" bolt (S-4108) and 5/8" nut (S-4110) may be placed in the top hole of the support column (E) for alignment purposes, but will be removed later when the sidewall base stiffener is to be positioned. Refer to [Figure 5C](#). Do not tighten bolts until hopper panels are installed to allow alignment.

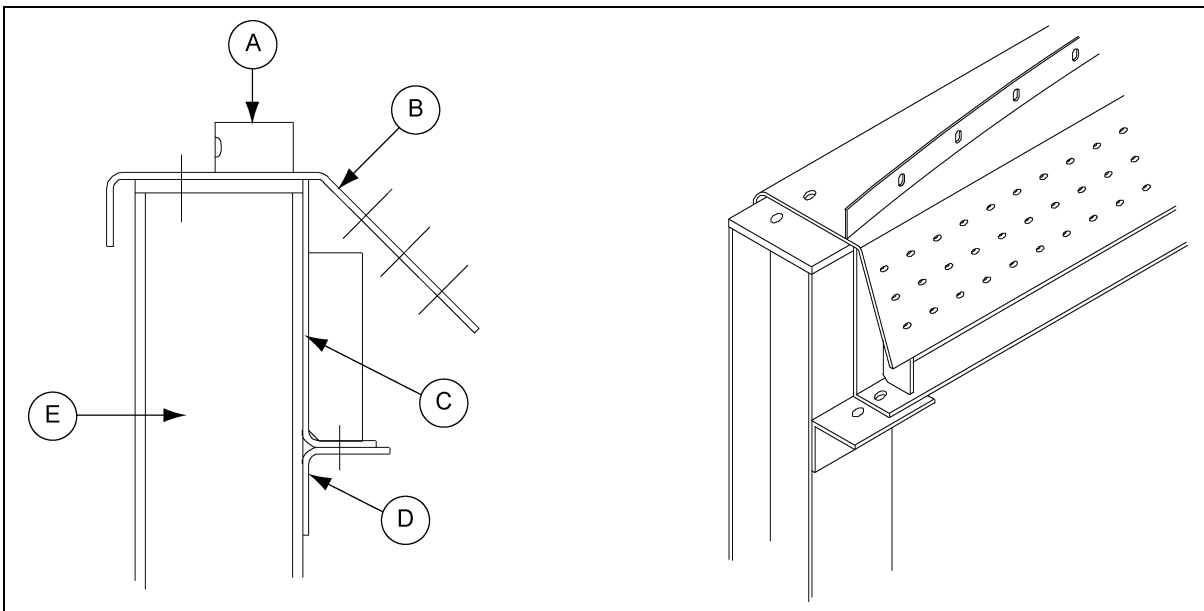

Figure 5C

Ref #	Description
A	Sealer Strip
B	Horizontal Compression Angle
C	Vertical Compression Angle

Ref #	Description
D	Support Clip
E	Support Column

Hopper Section Assembly 15'-24' (4.57 m-7.32 m) Diameter Hopper Tanks (Continued)

Begin assembling the hopper bottom by attaching a right and left pair or pairs of hopper panels to the compression angle ring (3/8" x 1" bin bolt (S-7487)) and discharge collar (1/2" x 1" hardware (S-4492)) at four (4) opposing points as shown in *Figure 5D*. Caulking is required on the vertical seams of the lapped hopper panels (Refer to *Figure 5G*). Splice plates which join the compression angle segments on the back side may be installed following a pair of hopper panels. Refer to *Figure 5F*. Complete this assembly by laying in alternate right and left panels moving around in one direction and lapping all sheets the same way, *See Figure 5E*. Do not tighten bolts until all hopper panels are attached to each other, the compression angle, splice plates and discharge collar.

On 15' through 24' tanks, use 1/2" bolts on hopper seams.

NOTE: All bolts used in hopper assembly should be installed with the bolt heads to the inside of the hopper.

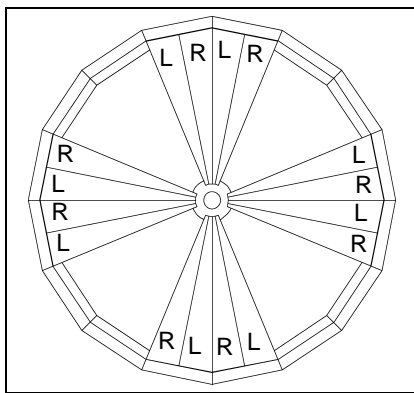

Figure 5D Hopper Panel and Discharge Collar Assembly

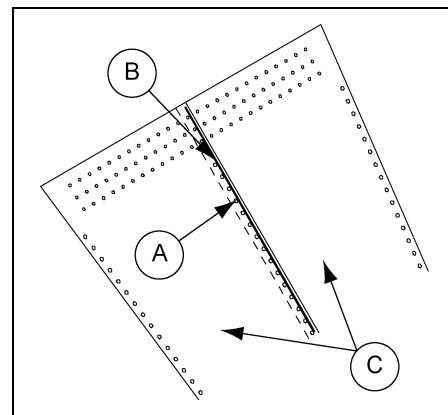

Figure 5G Detail A - Caulking Detail

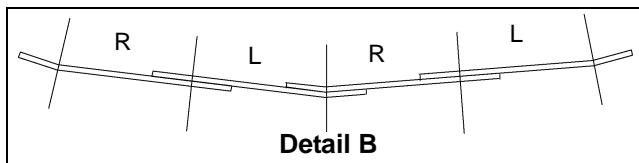

Figure 5E Lap Detail (Viewed from Inside of Bin)

Ref #	Description
A	1/2" Flange head bolts with nut on underneath side
B	Caulking
C	Hopper Panels

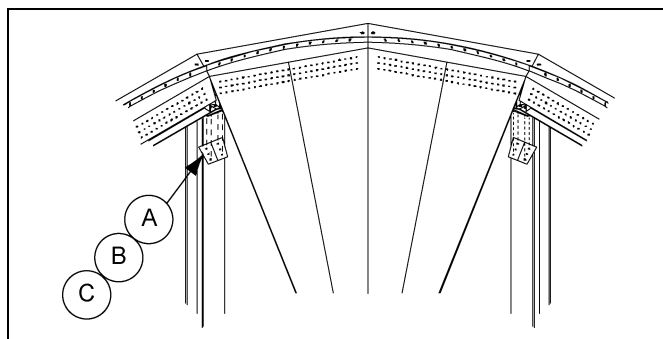

Figure 5F Hopper Panel Detail

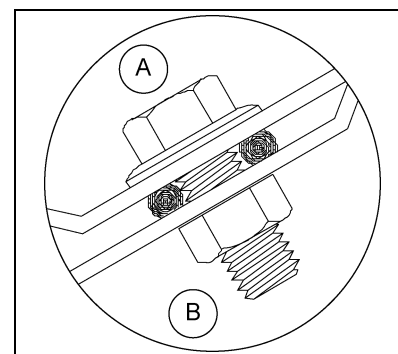

Figure 5H

Ref #	Ref #	Description
A	S-7488	3/8" x 1-1/2" Cap Screws
B	S-7489	3/8" Nut
C		Splice Plate

Ref #	Description
A	Inside
B	Outside

Start at the bottom of the hopper and tighten all bolts, including anchor bolts, discharge collar, hopper panels, splice plates and compression angle segments.

5. 15'-24' Hopper Assembly

Hopper Section Assembly 15'-24' (4.57 m-7.32 m) Diameter Hopper Tanks (Continued)

If a rack and pinion gate is purchased, install as shown in [Figure 5I](#) using 5/16" x 1" hardware (S-10260).

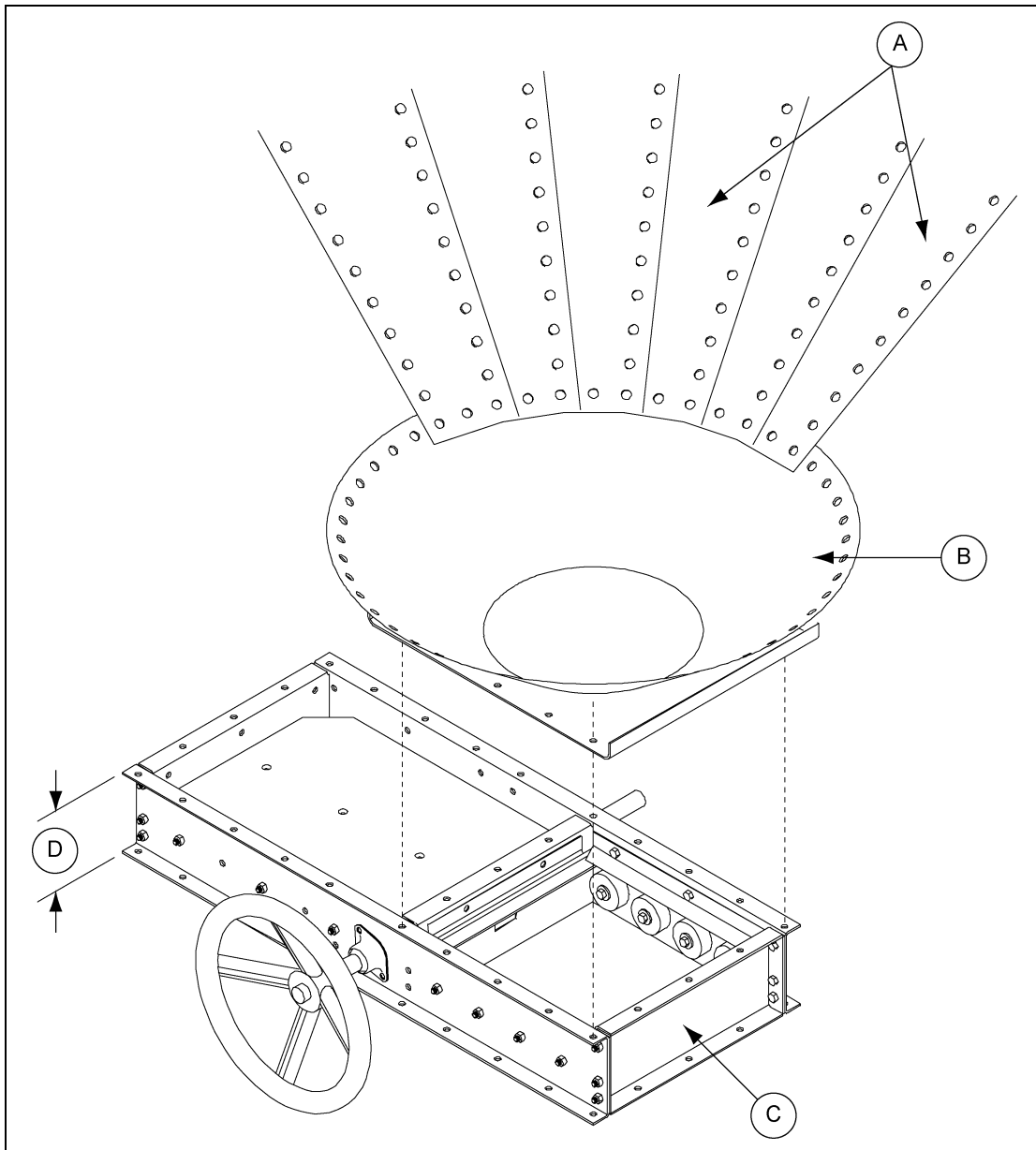

Figure 5I Hopper Discharge Collar to Roller Gate

Ref #	Description
A	Hopper Panels Right and Left
B	Discharge Collar Weldment
C	Roller Gate Assembly
D	5-1/2" Height

NOTE: Top extension plate may have to be loosened prior to discharge collar connection.

Hopper Section Assembly 15'-24' (4.57 m-7.32 m) Diameter Hopper Tanks (Continued)

Install "X" bracing rods (A) as shown in [Figure 5J](#), [Figure 5K](#) and [Figure 5L](#).

When the hopper structure has been completed, it should be level to within $\pm 1/8"$ maximum deviation, as compared to all other support columns (D) as measured at the top of the compression angle ring. The support columns must be plumb to within $\pm 1/2"$ as measured from top to bottom. Seal any gaps between compression elements and the seal strip at column locations with silicon or other conventional means.

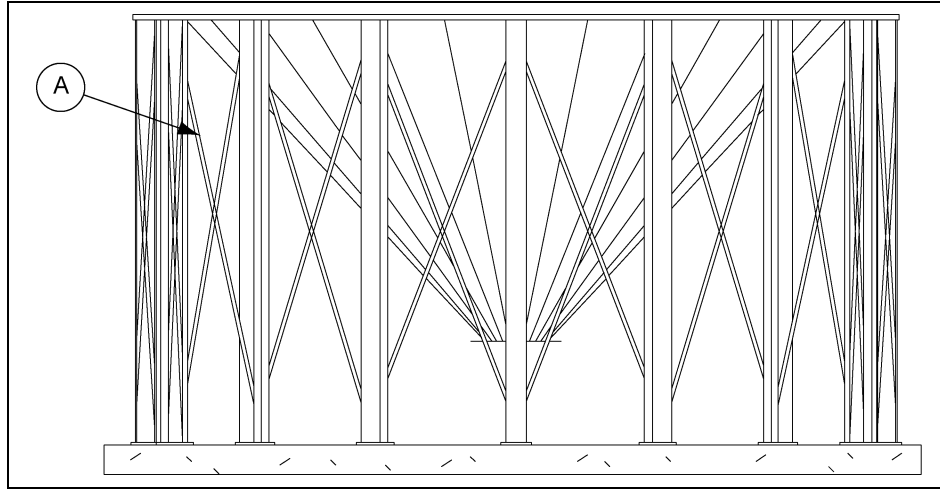

Figure 5J Completed Hopper Assembly

Ref #	Description
A	"X" Bracing Rods

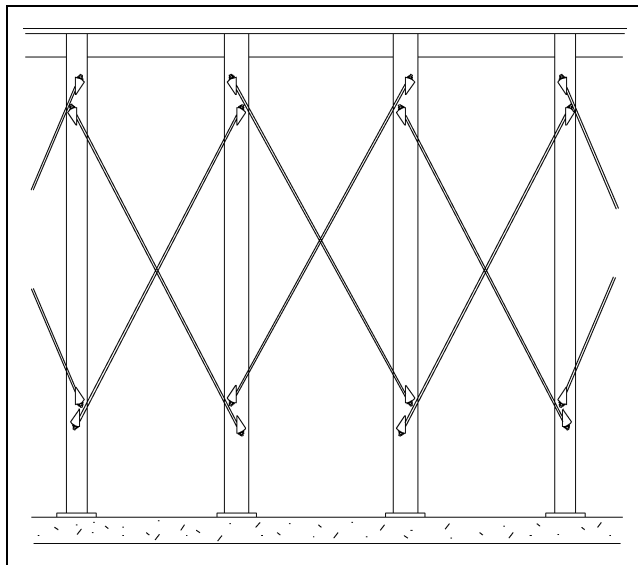

Figure 5K Detail C - "X" Bracing Rods

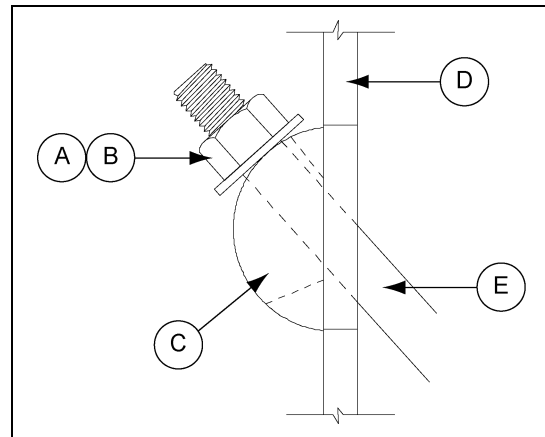

Figure 5L Detail D

Ref #	Part #	Description
A	S -234	* 3/4" Nut
B	S-866	* 3/4" Washer
C	CHT-1490	Crescent Washer
D		Support Column
E		"X" Bracing Rod

* **NOTE:** 15' - 60° Rods use 7/8" nut and washer.

5. 15'-24' Hopper Assembly

18'-21' (5.49 m-6.40 m) 60° “X” Bracing Detail

Install “X” bracing rods (A) as shown in [Figure 5M](#), [Figure 5N](#) and [Figure 5O](#).

When the hopper structure has been completed, it should be level to within $\pm 1/8$ " maximum deviation, as compared to all other support columns (C) as measured at the top of the compression angle ring. The support columns (C) must be plumb to within $\pm 1/2$ " as measured from top to bottom. Seal any gaps between compression elements and the seal strip at column locations with silicon or other conventional means.

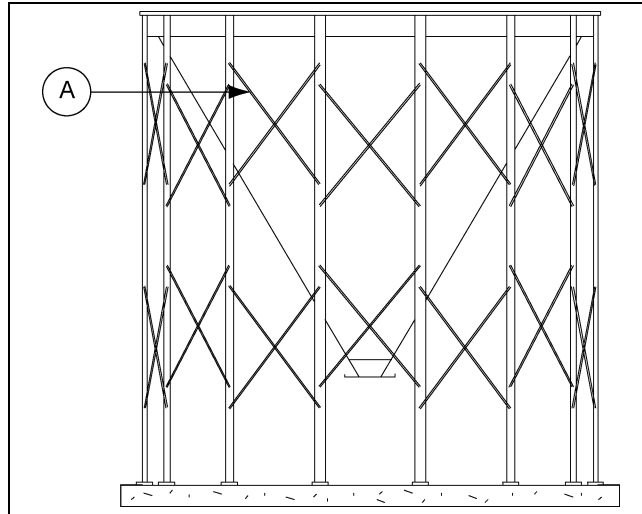

Figure 5M Completed Hopper Assembly

Ref #	Description
A	“X” Bracing Rods

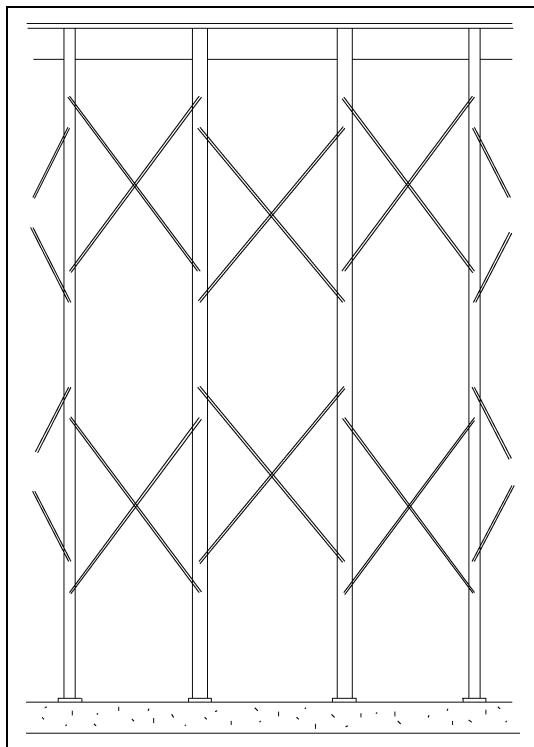

Figure 5N Detail E - “X” Bracing Rods

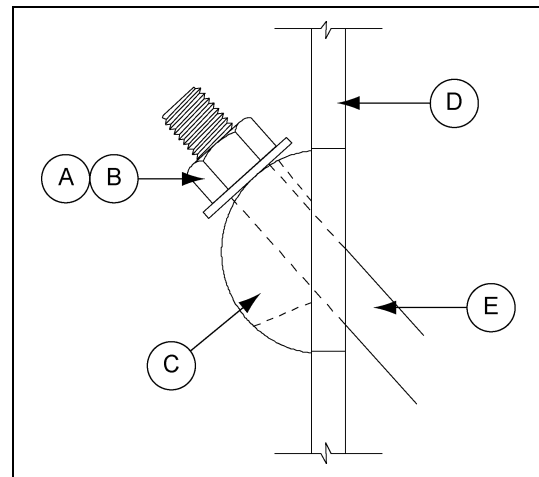

Figure 5O Detail F

Ref #	Ref #	Description
A	S-234	3/4" Nut
B	S-866	3/4" Washer
C	CHT-1490	Crescent Washer
D		Support Column
E		“X” Bracing Rod

Hopper Section Assembly 27'-30' (8.23 m-9.14 m) Diameter Hopper Tanks

Before placing the support columns on the anchor bolts, use a transit and surveyor's rod to locate high and low areas in the concrete. To assure level alignment for the support columns, use the proper supplied shim or shims between the concrete and base plate. After leveling is completed, place the support columns over the anchor bolts, with shim plates (B) underneath column. Next place washer (HT-635) over anchor bolts and loosely fasten with nuts and washers (not furnished). Refer to [Figure 6A](#). Seal any gaps between compression elements and the seal strip at column locations with silicon or other conventional means.

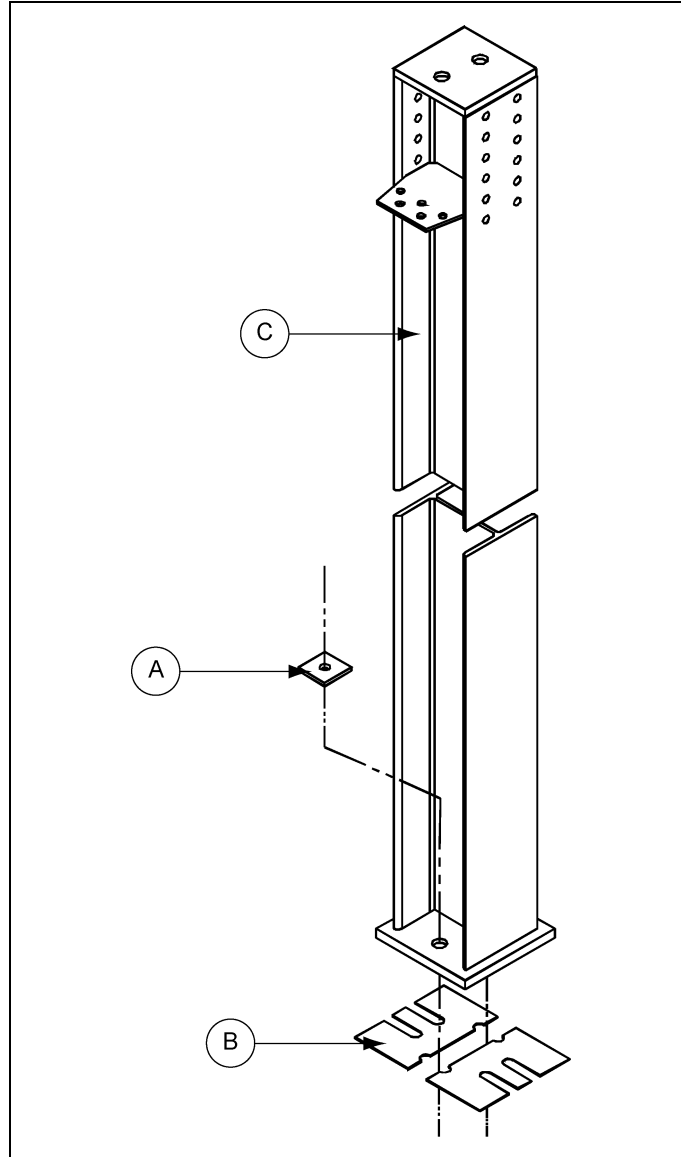

Figure 6A Column Shim Plate Detail (Use when Necessary)

Ref #	Part #	Description
A	HT-635	Square Washer for 3/4" Anchor Bolt
B	CHT-1160	Shim Plate
C		Column Weldment

6. 27'-30' Hopper Assembly

Hopper Section Assembly 27'-30' (8.23 m-9.14 m) Diameter Hopper Tanks (Continued)

Use a transit and surveyor's rod to locate high and low areas in the concrete, before placing the support columns on the anchor bolts. To assure level alignment, use the proper supplied shim or shims between the concrete and base plate. After leveling, place the support columns (C) over the anchor bolts, on the shims and loosely fasten with nuts and washers (not supplied). Refer to [Figure 6A on Page 39](#).

NOTE: 27' (8.23 m) Diameter hopper tanks have 18 columns.
30' (9.14 m) Diameter hopper tanks have 20 columns.

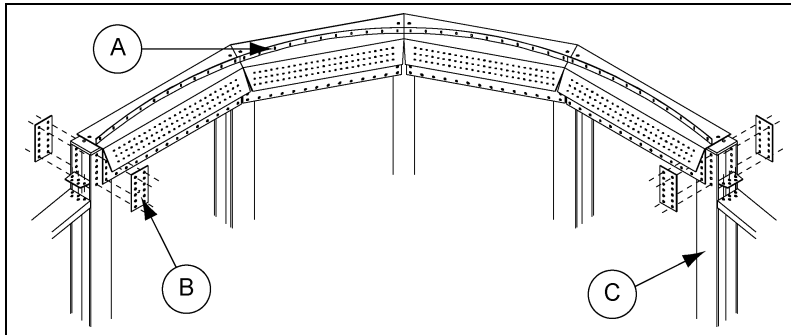

Figure 6B Compression Angle Erection

Ref #	Description
A	Compression Angle Segments
B	Splice Plate
C	Support Column

Using 5/8"-11 x 2" hardware (S-4329) (A), fasten the inside and outside vertical compression angle segments and splice plates to the support columns (G), [See Figure 6A on Page 39](#) and [Detail G in Figure 6C](#). Next, attach the horizontal channels with 5/8"-11 x 1-1/2" hardware (S-4109) (B) to the inside and outside vertical compression angle segments (E and F) and the support clips (B) on the support columns (G), as shown in [Detail H in Figure 6C](#). Do not tighten bolts until hopper panels are installed to allow alignment.

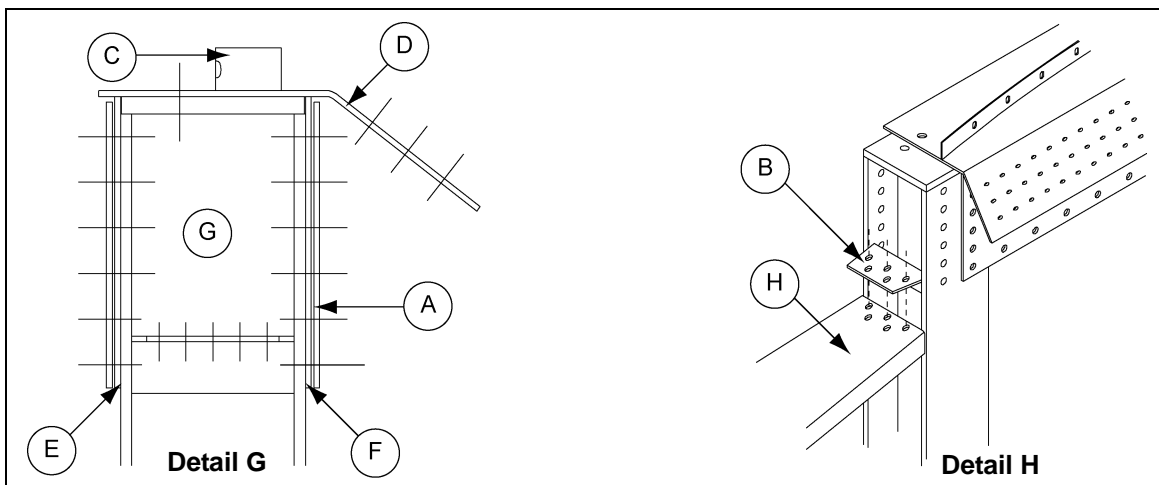

Figure 6C

Ref #	Part #	Description
A	S-4329	Splice Plate 5/8"-11 x 2" Hardware
B	S-4109	Support Clip 5/8"-11 x 1-1/2" Hardware
C		Sealer Strip
D		Compression Angle Weldment

Ref #	Description
E	Outside Vertical Compression Angle
F	Inside Vertical Compression Angle
G	Support Column
H	Horizontal Channel Fastened Under Support Clip

Hopper Section Assembly 27'-30' (8.23 m-9.14 m) Diameter Hopper Tanks (Continued)

Begin assembling the two (2) piece hopper bottom by attaching a right and left pair or pairs of the top hopper panels to the compression angle ring (3/8" x 1" bin bolts (S-7487) and 3/8" nut (S-7489)), along with the back side splice plates which use (3/8" x 1-1/2" bin bolts (S-7488) and 3/8" nut (S-7489)). Refer to [Figure 6F](#). All top panel seams use 5/8" x 1" hardware (S-4210) and 5/8" nut (S-4110). Once the top panels are positioned the bottom hopper panels may be attached to the top panels and discharge collar with 1/2" x 1" hardware (S-4492) and 1/2" nut (S-3729), at four (4) opposing points as shown in [Figure 6D](#). A 5/8" x 2" bolt (S-4329) and 5/8" nut (S-4110) is used on all corners of the spliced hopper panels. Refer to [Figure 6E](#) for bolt usage on hopper panels. Caulking is required on all vertical and horizontal seams of the hopper bottom, (refer to [Figure 6G](#)). Complete this assembly by laying in alternate right and left panels moving around in one direction and lapping all sheets the same way. Do not tighten bolts until all hopper panels are attached to each other, the compression ring, splice plates and discharge collar.

30' Commercial hopper tank has two (2) piece hopper as shown.

27' Commercial hopper tank has two (2) piece hopper as shown.

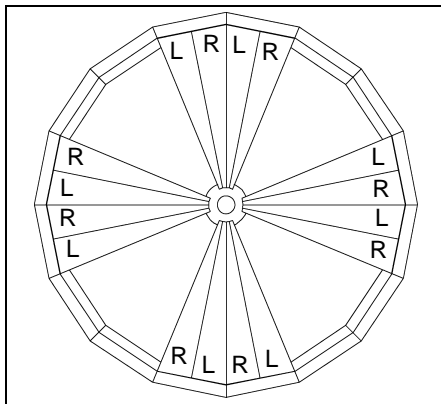

Figure 6D Hopper Panel and Discharge Collar Assembly

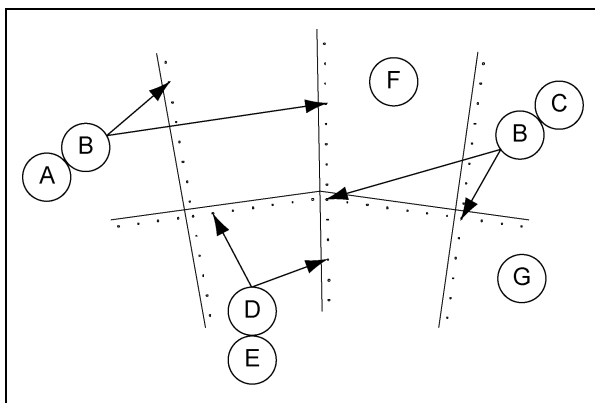

Figure 6E Detail J - Hopper Panel Bolt Usage

Ref #	Part #	Description
A	S-4210	5/8" x 1" Hardware
B	S-4110	5/8" Nut
C	S-4329	5/8" x 2" Bolt
D	S-4492	1/2" x 1" Hardware
E	S-3729	1/2" Nut
F		Top Panels
G		Bottom Panels

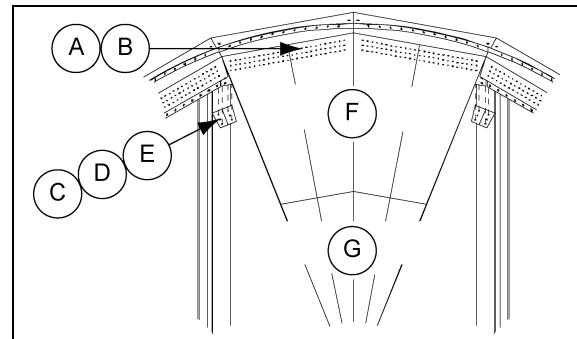

Figure 6F Hopper Panel Detail

Ref #	Part #	Description
A	S-7487	3/8" x 1" Bin Bolt
B	S-7489	3/8" Nut
C	S-7488	3/8" x 1-1/2" Cap Screws
D	S-7489	3/8" Nut
E		Splice Plates
F		Top Panels
G		Bottom Panels

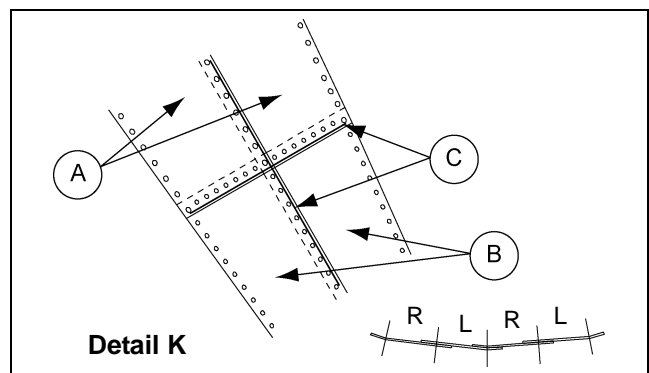

Figure 6G Caulking and Lap (Viewed from Inside of Bin)

Ref #	Description
A	Top Hopper Panels
B	Bottom Hopper Panels
C	Caulking

6. 27'-30' Hopper Assembly

Hopper Section Assembly 27'-30' (8.23 m-9.14 m) Diameter Hopper Tanks (Continued)

Start at the bottom of the hopper and tighten all bolts, including anchor bolts, discharge collar, hopper panels, splice plates and compression angle segments.

Install rack and pinion roller gate as shown in [Figure 5I on Page 36](#), using 5/16" x 1" hardware (S-10260).

Install "X" bracing as shown in [Figure 6H](#), [Figure 6I](#) and [Figure 6J](#).

When the hopper structure has been completed, it should be level to within $\pm 1/8$ " maximum deviation, as compared to all other support columns (D) as measured at the top of the compression angle ring. The support columns (D) must be plumb to within $\pm 1/2$ " as measured from top to bottom.

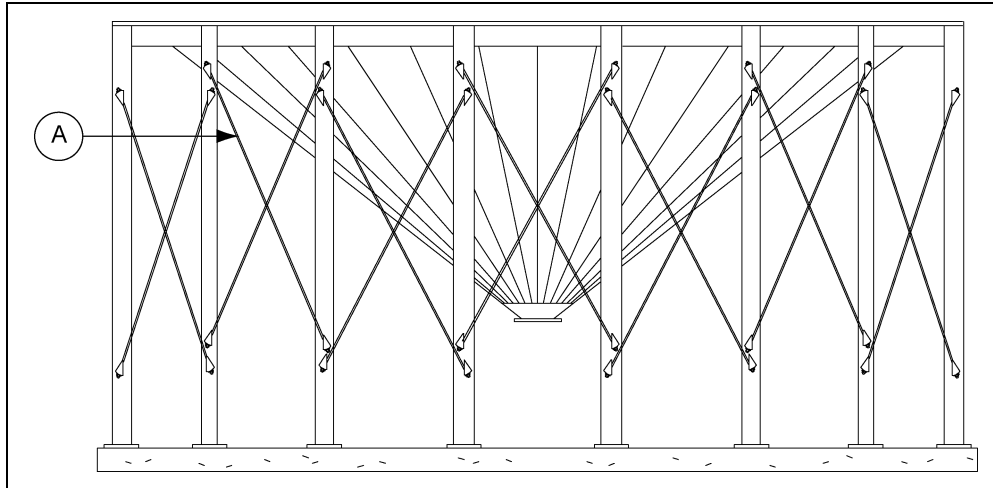

Figure 6H Completed Hopper Assembly

Ref #	Description
A	"X" Bracing Rods

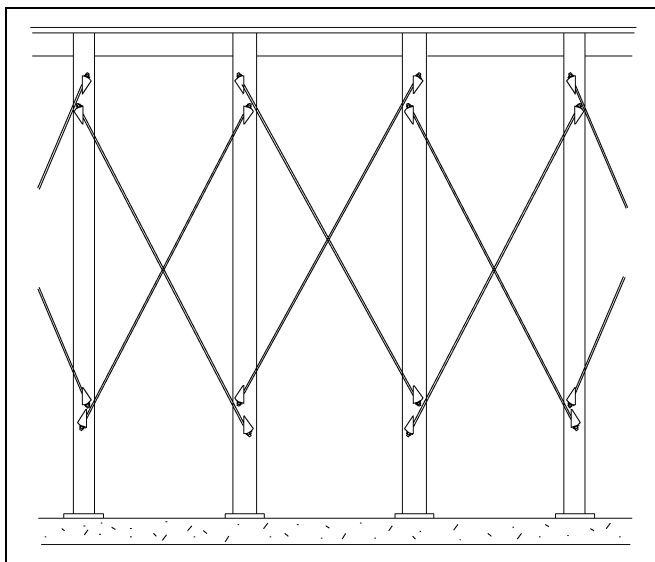

Figure 6I Detail L - "X" Bracing Rods

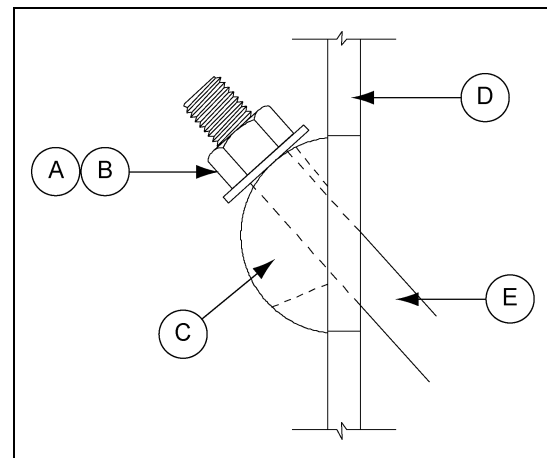

Figure 6J Detail M

Ref #	Part #	Description
A	S -234	3/4" Nut
B	S-866	3/4" Washer
C	CHT-1490	Crescent Washer
D		Support Column
E		"X" Bracing Rod

Sidewall Erection Instructions

Before bolting the sidewall sheets together, make sure that you are using the proper gauge steel for the first ring. The higher gauge numbers denote the thinner materials. (For example, 22 gauge material is thinner than 14 gauge.) In erecting most grain bins the thinnest material usually goes on top, therefore the first sidewall ring you assemble will be the top ring of the bin, usually the thinnest gauge. Check the various gauges of the bin with the color code chart and begin building accordingly. REMEMBER always assemble the top ring first.

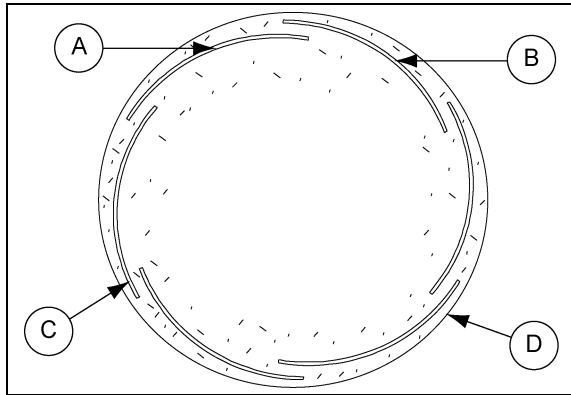

Figure 7A

Ref #	Description
A	Left Panel
B	Right Panel
C	Sidewall Sheet
D	Concrete Foundation

Once you have selected the proper gauge material, begin assembling all sidewall sheets. Stand on the inside the bin, place the left panel to the inside with the right panel to the outside. (See Figure 7A.)

NOTE: The rope caulking is installed before each sheet is assembled. Wipe sheet clean where caulking is to be applied. Refer to Page 52 for caulking placement.

Using correct size bin bolts throughout, begin assembling sidewall sheets end to end (overlapping the same way throughout) until the ring is completed. All body sheet bolts are to be installed with the bolt head and its neoprene washer to the outside and the nut on the inside. Do not tighten bolts until all sheets are assembled and form a complete ring. Lifting of sidewall should be done with jacks and lifting brackets on the stiffener bolt holes.

Decal Sheet Placement

NOTE: The decal sheets are located in the second ring from the top, evenly spaced around the diameter of the bin.

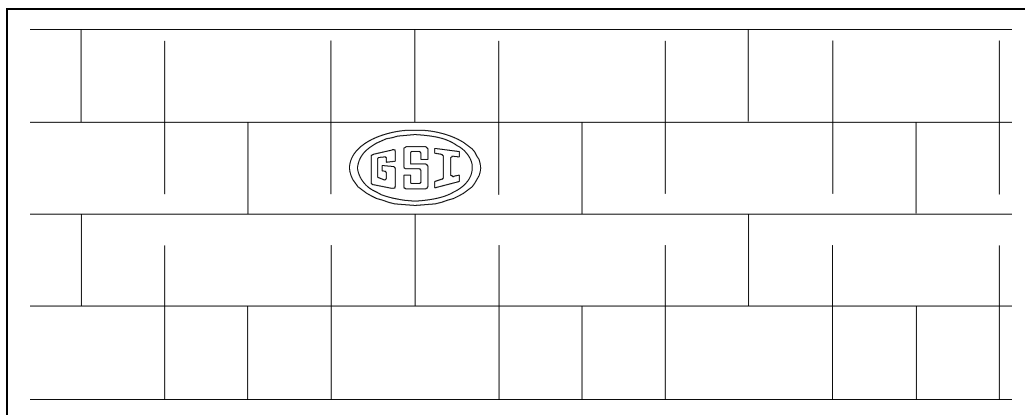

Figure 7B 2 Post - Two (2) rows of stiffeners used on each sidewall sheet.

NOTE: Dashed lines represent stiffener locations.

8. Lifting Jack

Lifting Jack Usage

Always consider the location of the door and other accessories prior to erecting the bin. Proper placement of lifting jacks in relationship to anchor bolts could make a difference on odd or even ring bins. Attachment of lifting brackets should be made on the stiffener row of bolts. The sidewall sheets are also staggered 1/2 from end to end.

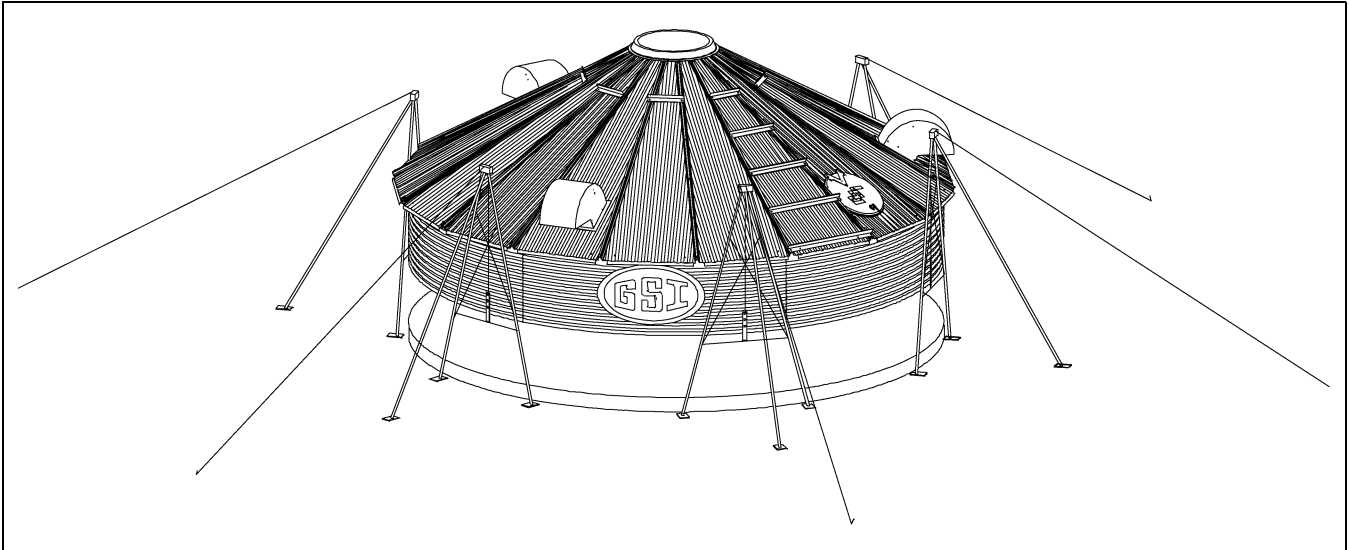

Figure 8A Anchor Jacks Securely

Anchor all jacks securely with metal stakes and cable. Raise the bin just high enough to assemble the next ring. When lifting the bin, crank all jacks at an equal rate. This will prevent previously assembled rings from bowing and make for easier hole alignment. To the inside of the first ring, bolt the next ring. Be sure to stagger the sheets and select the proper gauge material. To avoid excessive pulling of the holes in the sidewall, some stiffener lap and splice connections may go together easier if the sidewall is not tightened until the stiffeners have been put in place. Lower the bin on the foundation after assembling and tightening bolts on the new ring or rings. Next, re-bolt the lifting straps to the lowest ring in place thus far.

NOTES: Add inside and outside ladders to bin walls as you continue to raise the bin.

The number of lifting jacks required is best determined by personal experience. Factors such as bin size, soil compaction, wind velocity, jack design, etc., should be considered when deciding how many to use. If in doubt, use one jack on every other stiffener (one per sheet). Be sure to use heavy duty jacks for commercial installations.

Color Code Chart

2.66" Commercial Stiffeners

NOTE: Some colors are different than those used for sidewall sheets.

***NOTE:** Only Orange on 1 ring stiffener.

Stiffener Gauge	Color Code
15	Red/Orange*
14	Green/Orange*
13	Dark Blue
12	Black
11	Pink
10	Light Blue
9	Purple
8	Yellow
6	White
5	Fluorescent Green
5+12	Gold/Black
5+10	Gold/Light Blue
5+8	Gold/Yellow

2.66" Sidewall Gauges

NOTE: Some colors are different than those used for stiffener sheets.

Sidewall Gauge	Color Code
22	White
20	Red
19	Black/Yellow
18	Orange
17	Pink/Light Blue
16	Blue
15	Brown/Red
14	Green
13	Yellow/Blue
12	Black
11	Pink
10	Light Blue
9	Blue/Orange
8	Yellow

9. Hardware

Identifying Bolt Grades

(See Pages 36-39 for usage.)



Under no condition shall any other bolts be substituted for those supplied by the manufacturer.

Grade 2 Bolts

1. Grade 2 bolts are designated with a plain head and are **NOT** used in GSI grain bins/silos.

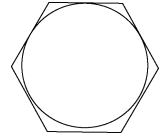

Grade 5 Bolts

2. Grade 5 bolts are designated by three (3) slash marks on the head. All 5/16" diameter bolts are to be grade 5 or higher.

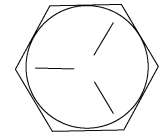

Grade 8 Bolts

3. Grade 8 bolts are designated by six (6) slash marks evenly spaced out around the head of the bolt.

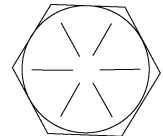

Grade 8.2 Bolts

4. Grade 8.2 bolts are designated by six (6) slash marks on the head in a sunrise pattern. All 3/8" diameter bolts are to be grade 8 or 8.2.

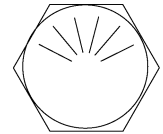

NOTE: Bolts should not be tightened in excess of the torque specifications.

Bolt Size	Torque (Ft. Lbs.)	
	Minimum	Maximum
5/16"-18	15	20
3/8"-16	35	42
7/16"-14	65	72
1/2"-13	95	105

Hardware Identification Notes

Refer to [2.66" Commercial Tank Bolting Requirements on Page 51](#) for complete bolt usage

S-10260

An S-10260 is a 5/16" x 1" JS bolt that is pre-assembled with a sealing washer.

Bolt (S-10260) is used in the following locations:

1. Use to connect roof panels together where they overlap.
2. Use when connecting eave angle to sidewall sheet.
3. The color of the bucket lid is lime green.
4. Use to connect eave clip to sidewall sheet on bins that are 48' diameter and smaller.
5. Use to attach roof panels to flashing on bins that are 48' diameter and smaller.

A	Side View
B	1.300" (3.30 cm)
C	1.000" (2.54 cm)

D	Top View
E	Grade 8
F	Grade 8.2

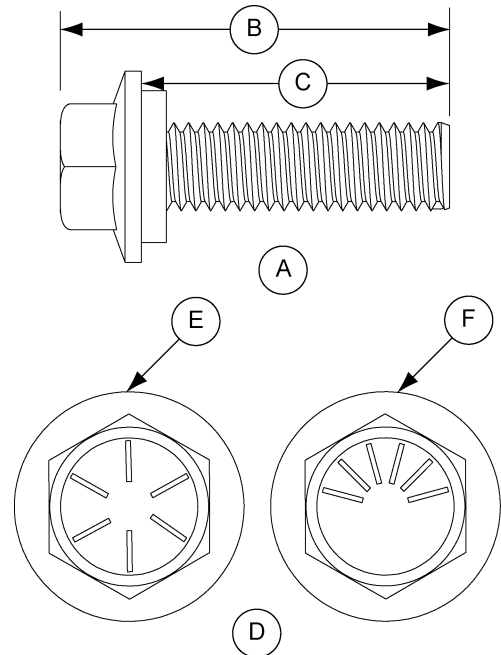

S-7483

An S-7483 is a 5/16" x 1-1/4" Pre-assembled with a plastic sealing washer.

Bolt (S-7483) is used in the following locations:

1. This bolt is primarily used to connect roof panels together where they overlap. It is also used at the bottom of the flat bottomed bins to attach the base angle to the sidewall sheet.
2. The color of the bucket lid is black.

A	Side View
B	1.550" (3.94 cm)
C	1.250" (3.18 cm)
D	Top View
E	Grade 8
F	Grade 8.2

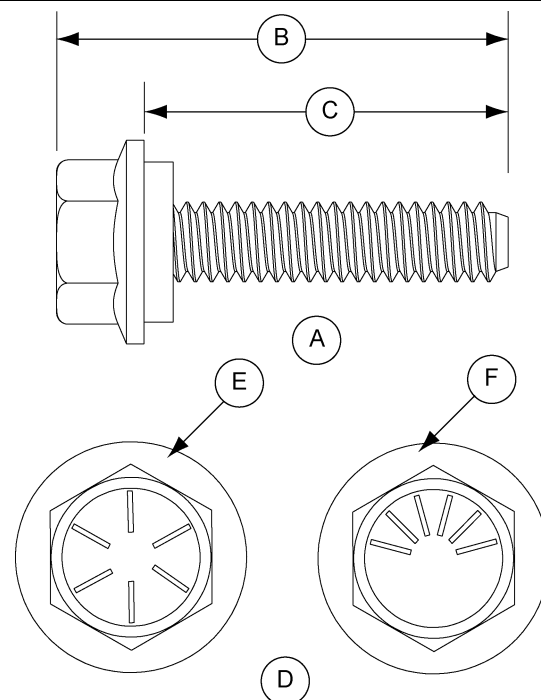

9. Hardware

Refer to [2.66" Commercial Tank Bolting Requirements on Page 51](#) for complete bolt usage (Continued)

S-7487

An S-7487 is a 3/8" x 1" JS bolt that is pre-assembled with a sealing washer.

Bolt (S-7487) is used in the following locations:

1. Use in all sidewall connections for 20 gauge through 10 gauge sidewall to sidewall sheets.
2. Use for horizontal and vertical seam connections for 9 gauge through 8 gauge sidewall sheets.
3. Use when attaching base angle to sidewall sheet on flat bottom bins.
4. The color of the bucket lid is grey.

NOTE: Do not use to splice the stiffeners together on the flanges where they connect to each other or the splice plates.

A	Side View	D	Top View
B	1.350" (3.43 cm)	E	Grade 8
C	1.000" (2.54 cm)	F	Grade 8.2

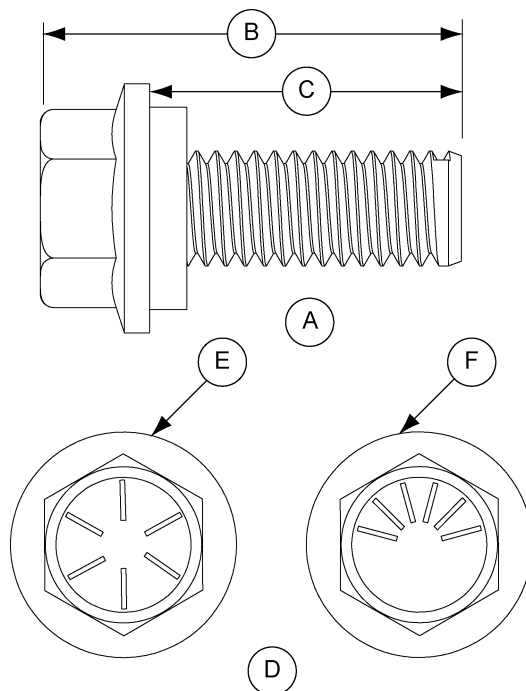

S-7488

An S-7488 is a 3/8" x 1-1/2" JS bolt that is pre-assembled with a sealing washer.

Bolt (S-7488) is used in the following locations:

1. Use in all stiffener to sidewall and overlap connections where the sidewall is 9 gauge or thicker.
2. Use in vertical and horizontal seams on sidewall that is 6 gauge or thicker.
3. The color of the bucket lid is orange.

NOTE: Do not use in flanges where the splice plate bolts to the stiffeners. Sealing washers should not be used for these connections.

A	Side View	D	Top View
B	1.850" (4.70 cm)	E	Grade 8
C	1.500" (3.81 cm)	F	Grade 8.2

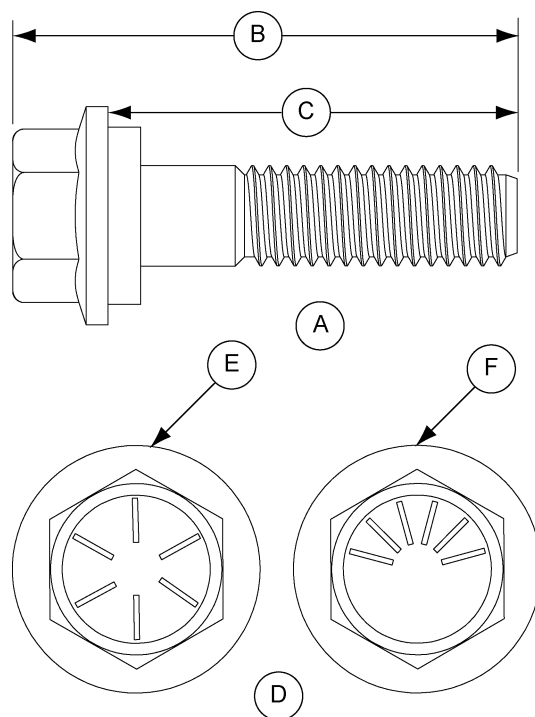

Refer to [2.66" Commercial Tank Bolting Requirements on Page 51](#) for complete bolt usage (Continued)

S-7485

An S-7485 is a 3/8" x 1" JS hex bolt with flanged head and without a sealing washer.

Bolt (S-7485) is used in the following locations:

1. Use to splice the stiffeners together on the flanges.
(A flange nut is used on the nut side of the connection.)
2. Use to splice the laminated stiffeners together. (A flange nut is used on the nut side of the connection.)
3. The color of the bucket lid is light green.

A	Side View
B	1.350" (3.43 cm)
C	1.000" (2.54 cm)
D	Top View
E	Grade 8
F	Grade 8.2

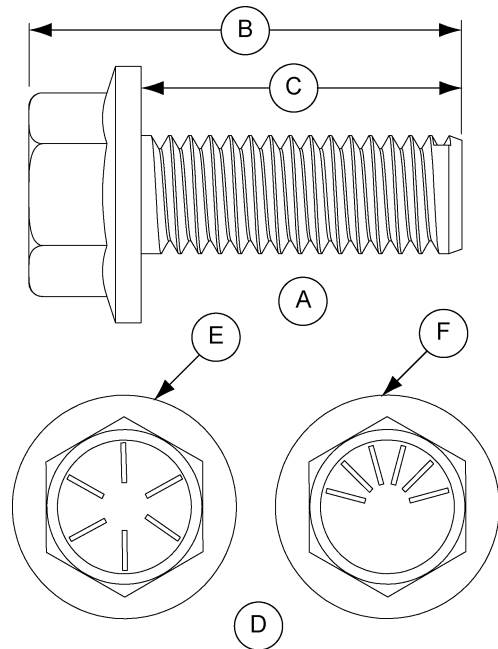

S-7486

An S-7486 is a 3/8" x 1-1/2" JS hex bolt with a flanged head without a sealing washer.

Bolt (S-7486) is used in the following locations:

1. Use in special seismic tanks.
2. The color of the bucket lid is dark brown.

A	Side View
B	1.850" (4.70 cm)
C	1.500" (3.81 cm)
D	Top View
E	Grade 8
F	Grade 8.2

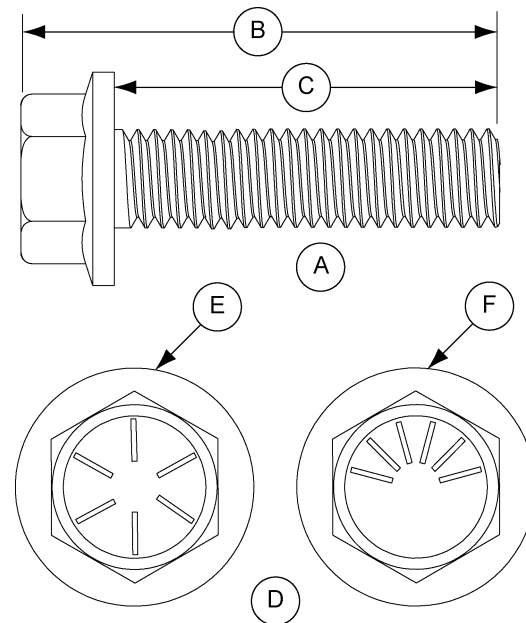

















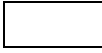

NOTE: The only washers shipped loose with the bins are the steel flat washers. The 5/16" steel flat washer (S-845) is used where the base angle attaches to the sheet and some are used the main eave clips. The 3/8" steel flat washers (S-248) are used at the stiffener splices and some are used in the roof rafter splices.

9. Hardware

Color Chart for Bin Hardware Bucket Lids

For ease of identification, hardware is separated and identified by buckets with color coded lids. Use the following chart to help identify the correct hardware.

JS Part #	YDP Part #	Color	Bucket Count	Lid Color	Description
S-7482	S-275	Dark Blue	1500		5/16" x 3/4" Bolt pre-assembled with sealing washer
NA	S-10260	Lime Green	1250		5/16" x 1" Bolt pre-assembled with sealing washer
S-7483	S-277	Black	1000		5/16" x 1-1/4" Bolt pre-assembled with sealing washer
S-7484	S-396	Red	5000		5/16" Hex nut
S-10268	S-3611	Gold	NA		5/16" Flange nut
S-7487	S-455	Grey	850		3/8" x 1" Bolt pre-assembled with sealing washer
S-7485	S-7927	Light Green	1000		3/8" x 1" Flanged bolt without sealing washer
S-7488	S-5060	Orange	650		3/8" x 1-1/2" Bolt pre-assembled with sealing washer
S-7486	S-7928	Dark Brown	700		3/8" x 1-1/2" Flange bolt without sealing washer
S-10165	S-9445	Light Blue	500		3/8" x 2" Bolt pre-assembled with sealing washer
S-7489	S-456	Yellow	4000		3/8" Hex nut
S-9426	S-9373	Dark Purple	2500		3/8" Hex flanged nut
NA	S-10250	NA	NA	In Box	7/16" x 1-1/4" Flanged bolt
S-10262	S-9464	White	500		7/16" x 1-1/2" Flange bolt pre-assembled with sealing washer
S-9389	S-10114	Light Purple	350		7/16" x 2" Bolt pre-assembled with sealing washer
S-10134	S-9444	Dark Green	300		7/16" x 2-1/2" Bolt pre-assembled with sealing washer
S-10261	NA	Natural (Clear)	200		7/16" x 3-1/4" Flange bolt pre-assembled with sealing washer
S-9281	S-7332	Fire Orange	1500		7/16" Hex nut
NA	S-8479	Light Brown	800		7/16" Special recessed nut
NA	S-10251	NA	NA	In Box	7/16" Un-serrated flange nut
NA	S-10252	NA	NA	In Box	1/2" x 1-3/4" Flange bolt
NA	S-10253	NA	NA	In Box	1/2" Un-serrated flange nut

2.66" Commercial Tank Bolting Requirements 2 Stiffeners per Sidewall Sheet

Sidewall Seams and Stiffener to Sidewall Bolt Usage

Sidewall Gauge	Horizontal Seam	Vertical Seam	Stiffener to Sidewall	Overlap Seam
20-19	5/16" x 3/4" [10]	5/16" x 3/4" [24]	3/8" x 1" [8]	5/16" x 3/4" [2]
18T	5/16" x 3/4" [22]	5/16" x 3/4" [36]	3/8" x 1" [16]	5/16" x 3/4" [2]
17T-16T	5/16" x 3/4" [22]	5/16" x 3/4" [36]	3/8" x 1" [24]	5/16" x 3/4" [2]
15Q-14Q	5/16" x 3/4" [22]	5/16" x 3/4" [48]	3/8" x 1" [24]	5/16" x 3/4" [2]
13Q-10Q	3/8" x 1" [22]	3/8" x 1" [48]	3/8" x 1" [24]	3/8" x 1" [2]

A. T - Triple punched sheets (36 holes in vertical seam)

Q - Quad punched sheets (48 holes in vertical seams)

All bolts are standard bin bolts with neoprene washers. For horizontal and vertical seam bolts, the bolt head and neoprene washers are on the outside of the bin. Refer to stiffener instructions on stiffener to sidewall bolt usage on [Page 53](#).

B. Hardware part numbers

5/16" x 1" - S-10260

3/8" x 1" - S-7487

C. [See Pages 53-59](#) for special instructions on stiffener to sidewall bolt usage for stiffener splices and laminated stiffeners.

D. Use 5/16" bolts and nuts when joining 14 gauge to 13 gauge on horizontal seams.

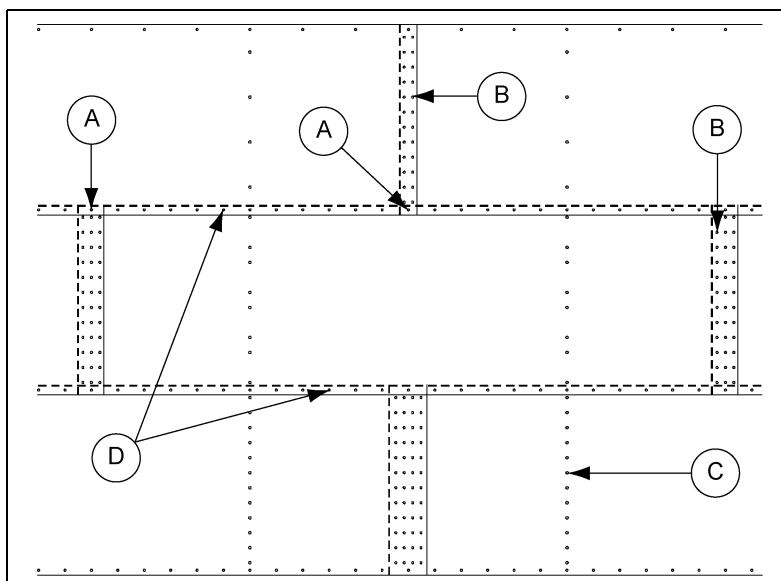

Figure 9A 18 Gauge Sidewall Sheet

Ref #	Description
A	Overlap Seam
B	Vertical Seam

Ref #	Description
D	Horizontal Seam
D	Stiffener to Sidewall Standard Stiffened Punched

Caulking Detail

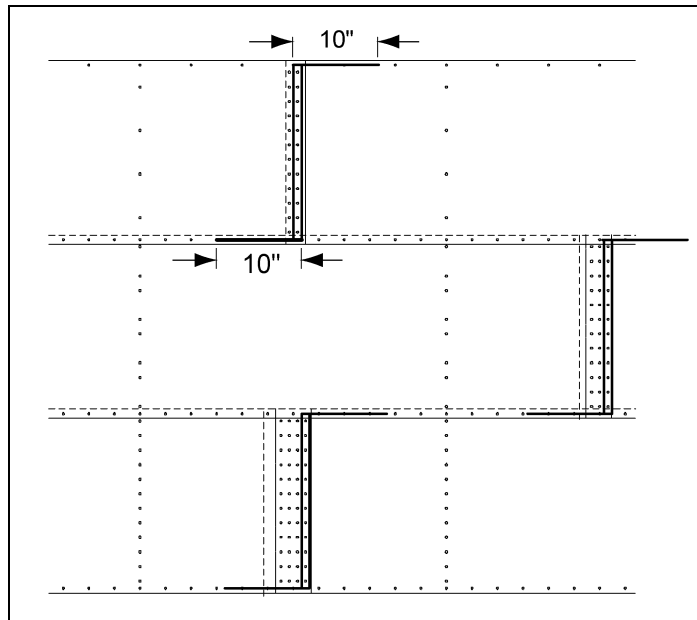

Figure 9B Standard, Triple and Quad Punched Sidewall Sheets as Viewed from Outside

Apply one strip of caulking near the outside edge of the outer sheet and between the outer two (2) rows of bolts, refer to [Figure 9C](#). A strip of caulking 10" long, should be placed along the horizontal seams. Before bolting the next ring in place, apply one strip of caulking 10" long on the front of the underlapped sheet at each joint. Also, a 10" strip of caulking is to be placed along the lower horizontal edge of lapping sheet at every vertical seam. This will fill the space that occurs between the holes caused by the overlapped sheets. Additional 10" strips should be used to fill gaps that occur with heavier gauges.

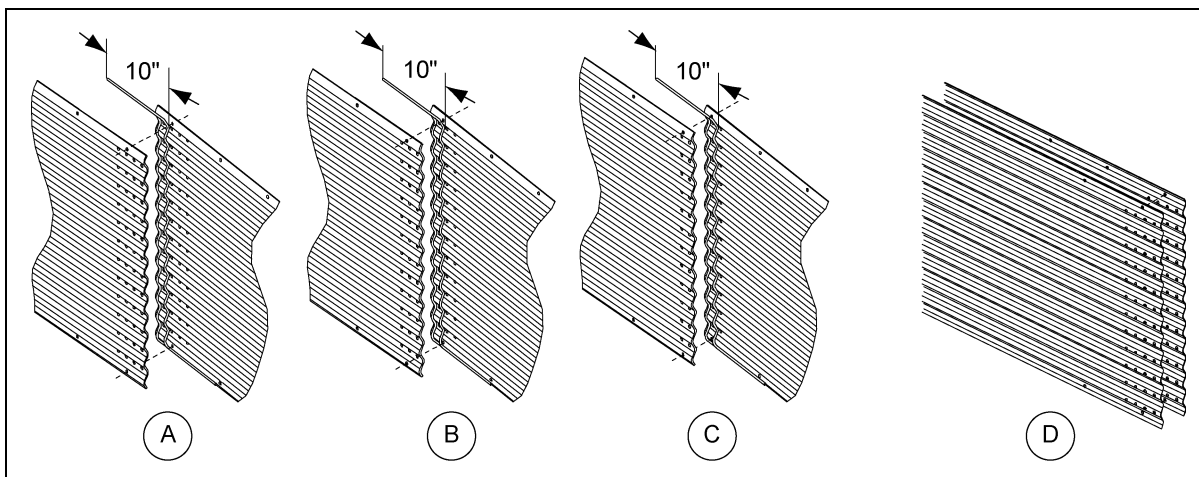

Figure 9C As Viewed from Inside of Bin (Externally stiffened reverse-rolled sheets shown.)

Ref #	Description
A	Quad Punch Caulking Detail
B	Triple Punch Caulking Detail
C	Double Punch Caulking Detail
D	Laminated Sheet Detail (Caulking not shown.)

Universal Stiffener and Splice Hardware

Stiffeners	Splicing Systems
12 Gauge to 12 Gauge and Thinner	Offset/Lapped Stiffener No Separate Splices Plate
12 Gauge to 11 Gauge through 8 Gauge to 5 Gauge and 6 Gauge	Use SS-7053 Splice Color Code: Yellow
5 Gauge and 6 Gauge to 5 Gauge and 6 Gauge	Use SS-7053 Splice Color Code: Yellow
5 Gauge to Laminated Laminated to Laminated	Use SS-6966 or SS-7427 Splice 2 per Joint

Splice Hardware Usage (Not Including Sidewall to Splice Bolts)

Stiffeners	Splicing Systems	Hardware Part #	Description	Qty
14 Gauge and 15 Gauge	Offset Stiffener Joint	S-7485	3/8" x 1" Flange Bolts	8
		S-9426	3/8" Flange Nuts	8
12 Gauge and 13 Gauge	Offset Stiffener Joint	S-7485	3/8" x 1" Flange Bolts	10
		S-9426	3/8" Flange Nuts	10
10 Gauge and 11 Gauge	SS-7053 8 Gauge Splice Plate	S-7485	3/8" x 1" Flange Bolts	16
		S-9426	3/8" Flange Nuts	16
8 Gauge and 9 Gauge	SS-7053 8 Gauge Splice Plate	S-7485	3/8" x 1" Flange Bolts	20
		S-9426	3/8" Flange Nuts	20
5 Gauge and 6 Gauge	SS-7053 8 Gauge Splice Plate	S-7486	3/8" x 1-1/2" Flange Bolts	20
		S-9426	3/8" Flange Nuts	20
Laminated	SS-6966 or SS-7427	S-7486	3/8" x 1-1/2" Flange Bolts	30
		S-9426	3/8" Flange Nuts	30

Stiffener to Sidewall Hardware Usage

Splicing Systems	Hardware Part #	Description
Stiffener to Sidewall	S-7487	3/8" x 1" Flange Bolts
	S-9426	3/8" Flange Nuts
SS-7053 Splice to Sidewall	S-7488	3/8" x 1-1/2" Flange Bolts
	S-9426	3/8" Flange Nuts
Laminated Stiffener to Sidewall	S-7488	3/8" x 1-1/2" Flange Bolts
	S-9426	3/8" Flange Nuts

10. Stiffeners

Commercial Stiffeners for 2.66" Corrugation

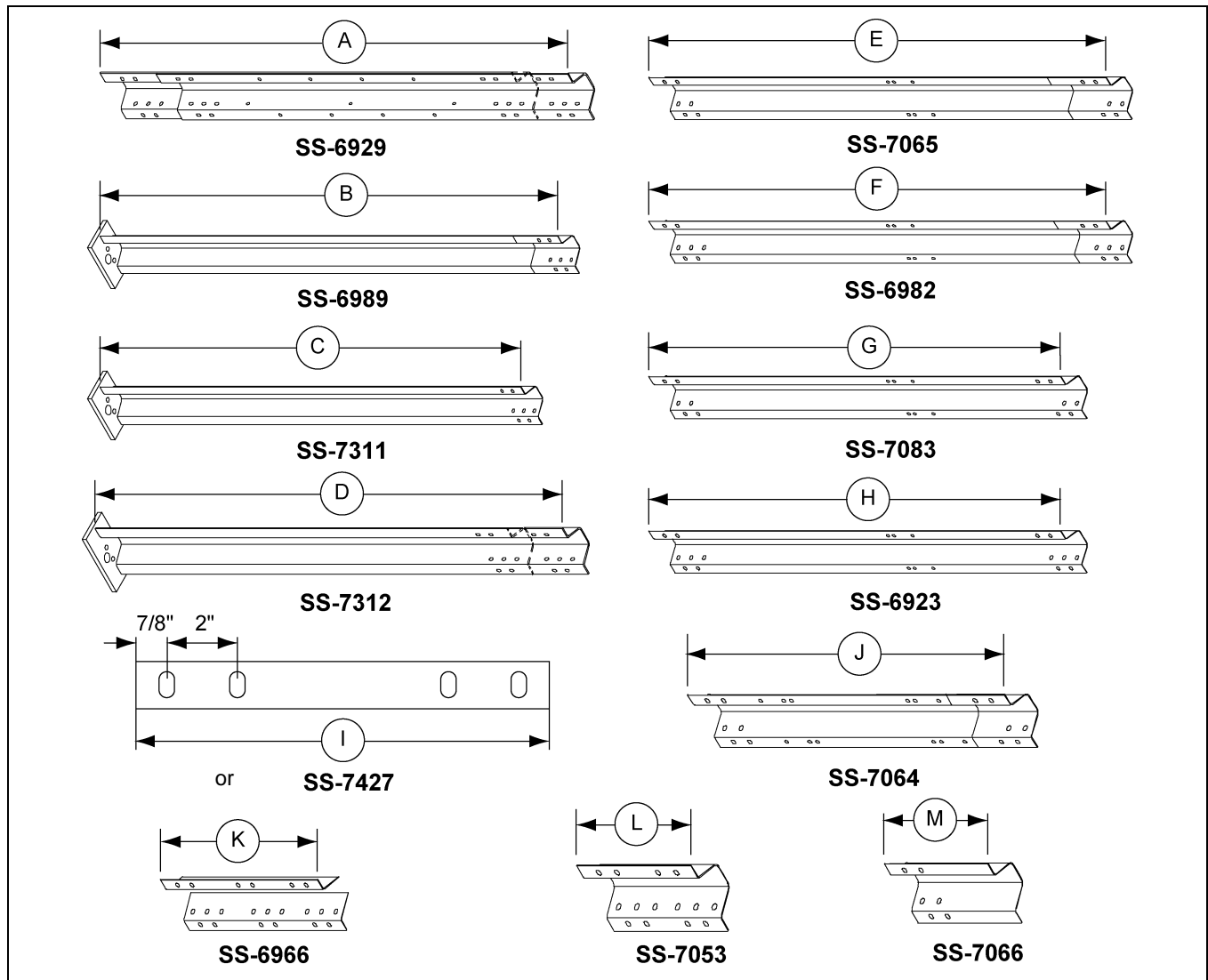

Figure 10A

Ref #	Part #	Description	Length
A	SS-6929	2 Ring Laminated Stiffener	71.906" (182.642 cm)
B	SS-6989	Offset Base Stiffener	87-1/8" (180.260 cm)
C	SS-7311	Base Stiffener	80.094" (203.438 cm)
D	SS-7312	Universal Stiffener Laminated Base Weldment	88.094" (223.758 cm)
E	SS-7065	14 Gauge and 15 Gauge 2 Ring Stiffener	70.969" (180.260 cm)
F	SS-6982	12 Gauge and 13 Gauge 2 Ring Stiffener	70.969" (180.260 cm)
G	SS-7083	10 Gauge and 11 Gauge 2 Ring Stiffener	63.938" (162.401 cm)
H	SS-6923	5 Gauge, 6 Gauge, 8 Gauge and 9 Gauge 2 Ring Stiffener	63.938" (162.401 cm)
I	SS-7427	Laminated Back Plate Splice	11-3/4" (29.85 cm)
J	SS-7064	Offset 1 Ring Stiffener	38.969" (98.981 cm)
K	SS-6966	Laminated Back Plate	22" (55.88 cm)
L	SS-7053	8 Gauge Splice	14" (35.56 cm)
M	SS-7066	1 Ring Top	12.469" (31.671 cm)

2.66" Corrugation Commercial Stiffener Splice Details

When installing bottom stiffeners, in some cases the stiffener with the base plate attached will not rest on support structure. Shim plates have been furnished and should be used to fill opening between base plate and compression element. See [Page 65](#) for detail.

IMPORTANT: *If shim plates are not used where required, the downward pressure of the stiffeners will not be transferred directly to the foundation and bin failure could result.*

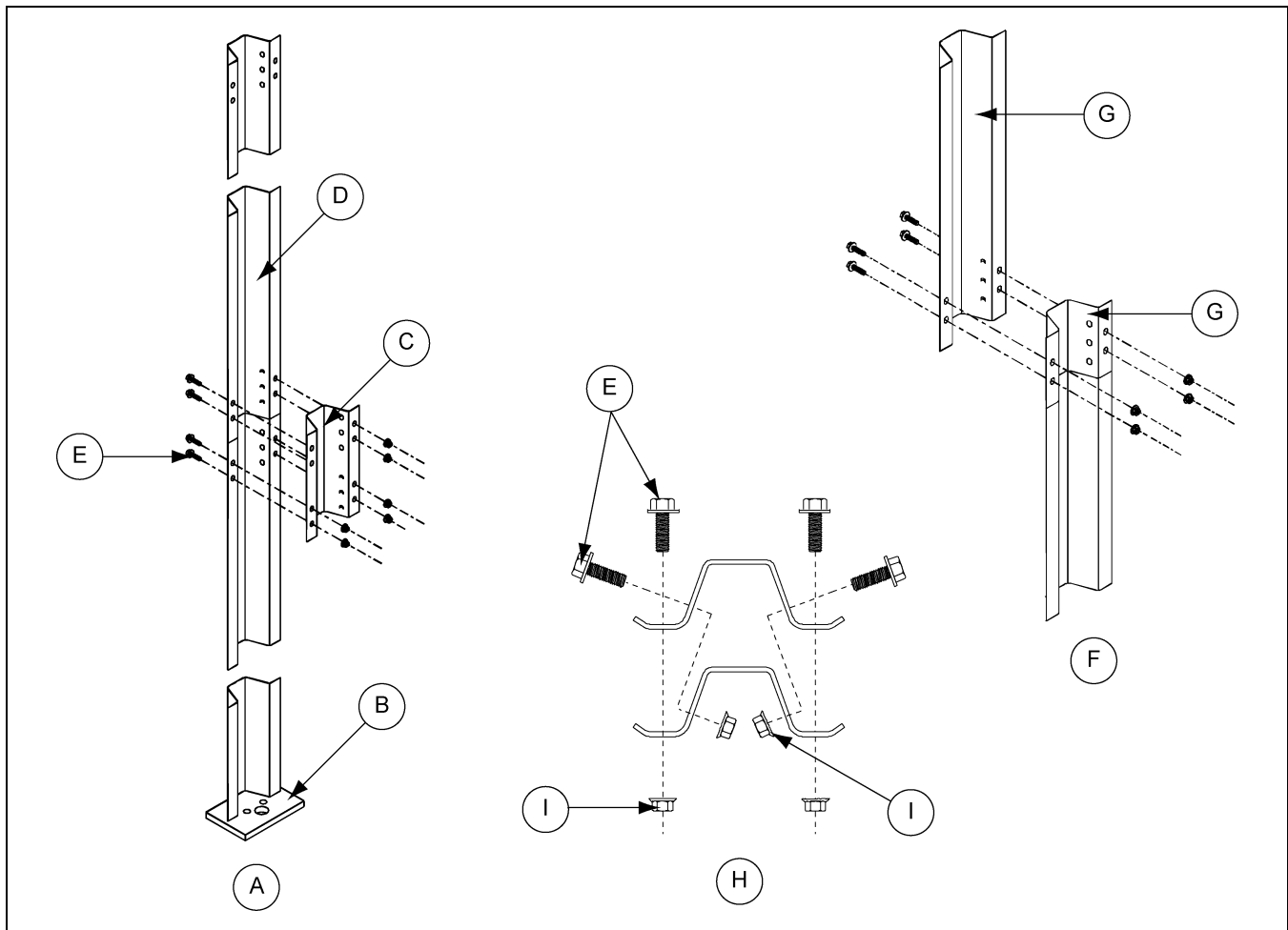

Figure 10B

Ref #	Description
A	Splice Plate Joint Detail (Non-Offset Joint)
B	Base Stiffener (SS-6976)
C	Splice Plate 8 Gauge (Yellow) (SS-7053)
D	2 Ring Standard Stiffener
E	3/8" Diameter Hex Flanged Head Bolt (No Sealing Washer)
F	Offset Joint Connection Detail
G	Standard Offset Stiffener
H	Splice Plate Joint (Top View)
I	Use 3/8" x 1" Bolt and Flange Nut

NOTE: *See Pages 56-59 for further details.*

2.66" Corrugation Commercial Stiffener Splice Details (Continued)

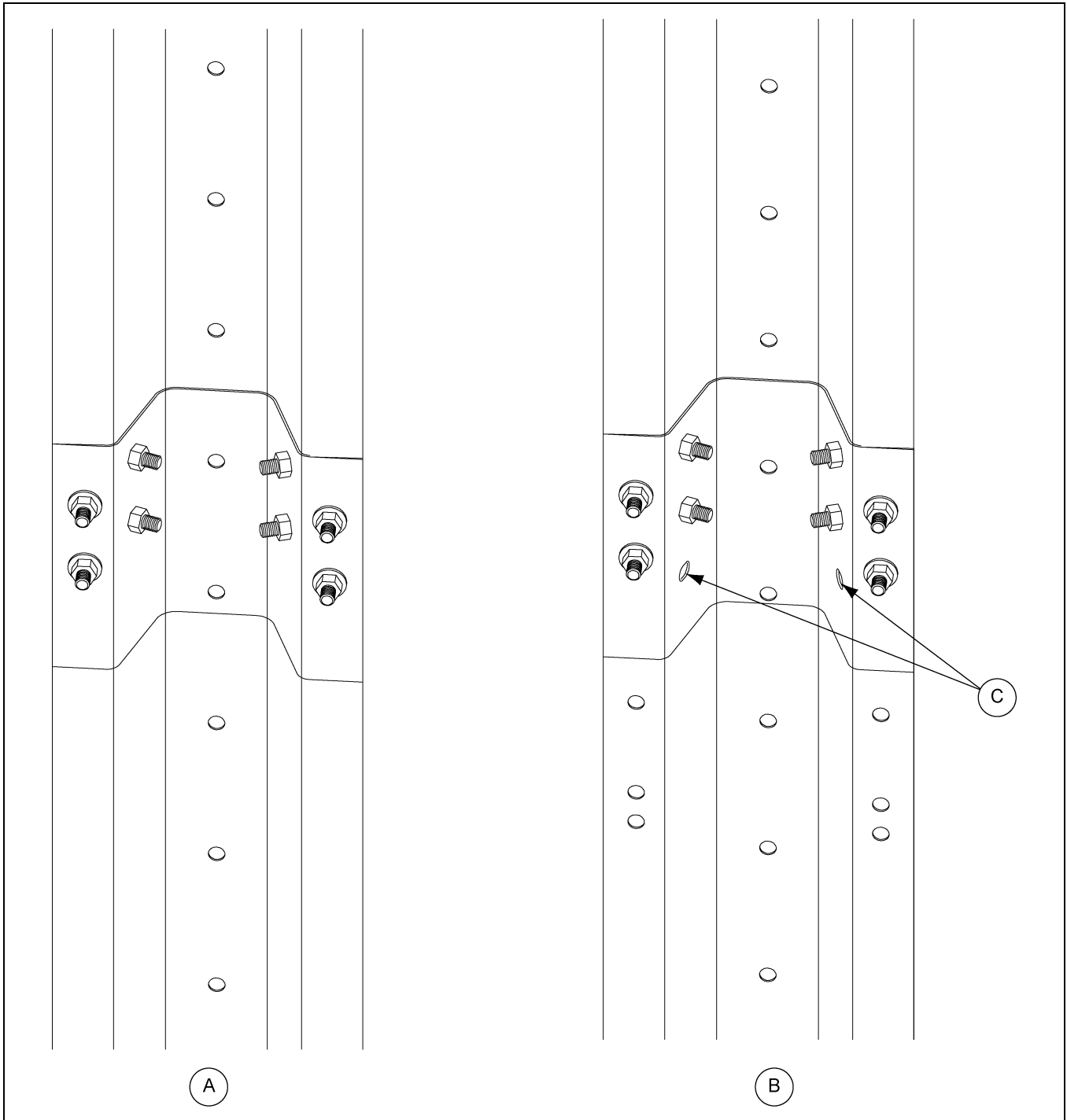

Figure 10C

Ref #	Description
A	14 Gauge and 15 Gauge to 14 Gauge and 15 Gauge Offset Connection Detail
B	14 Gauge and 15 Gauge to 13 Gauge and 12 Gauge Offset Connection Detail
C	Bolt hole not used in 14 gauge and 15 gauge. Do not drill.

10 Gauge and 11 Gauge Stiffener Bearing Splice

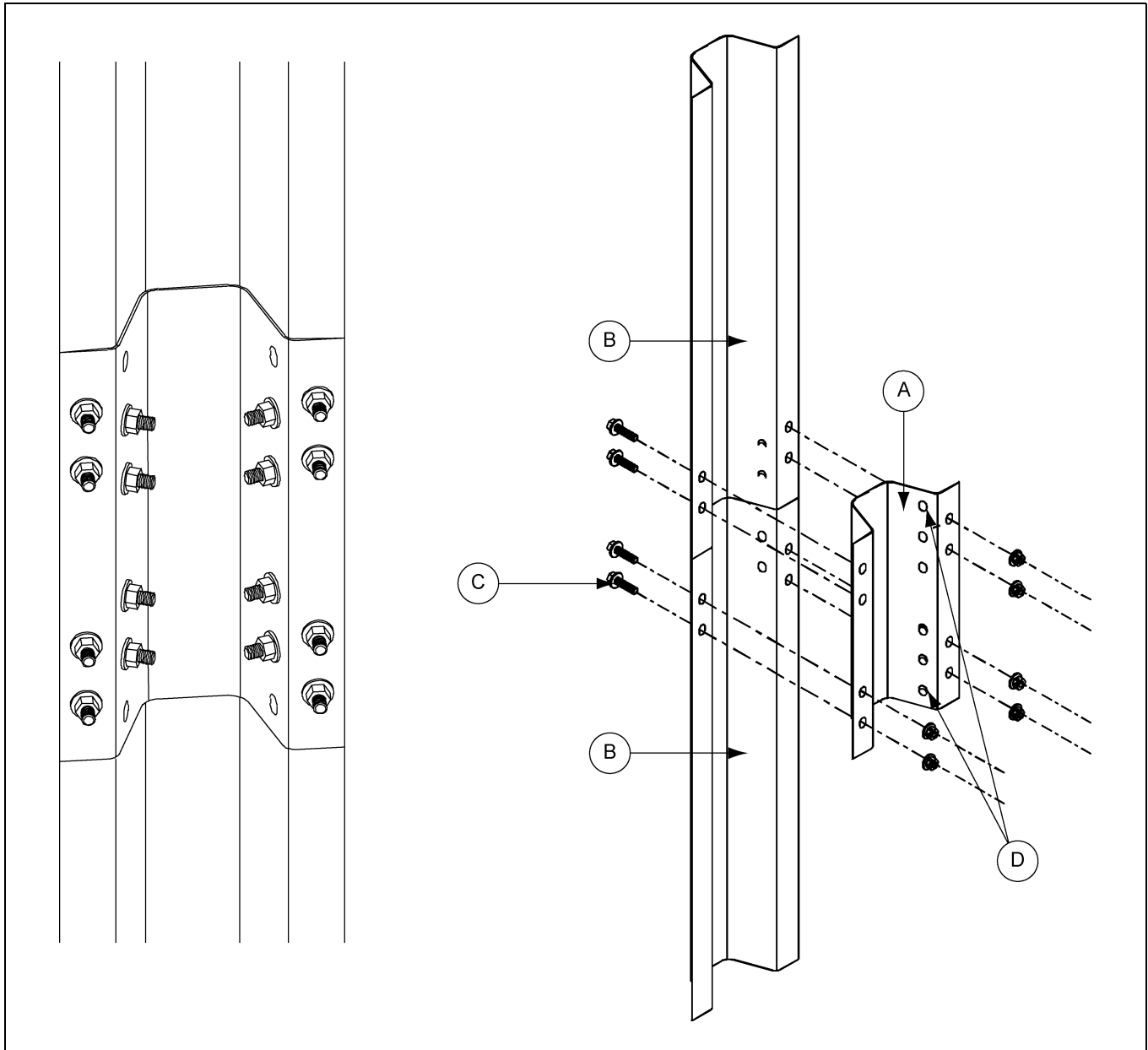

Figure 10D

Ref #	Description
A	Splice Plate 8 Gauge (SS-7053)
B	10 Gauge or 11 Gauge Standard Stiffener
C	3/8" Diameter Hex Flanged Head Bolt (No Sealing Washer)
D	Bolt holes in splice plate not used. Do not drill.

10. Stiffeners

5 Gauge, 6 Gauge, 8 Gauge and 9 Gauge Stiffener Bearing Splice

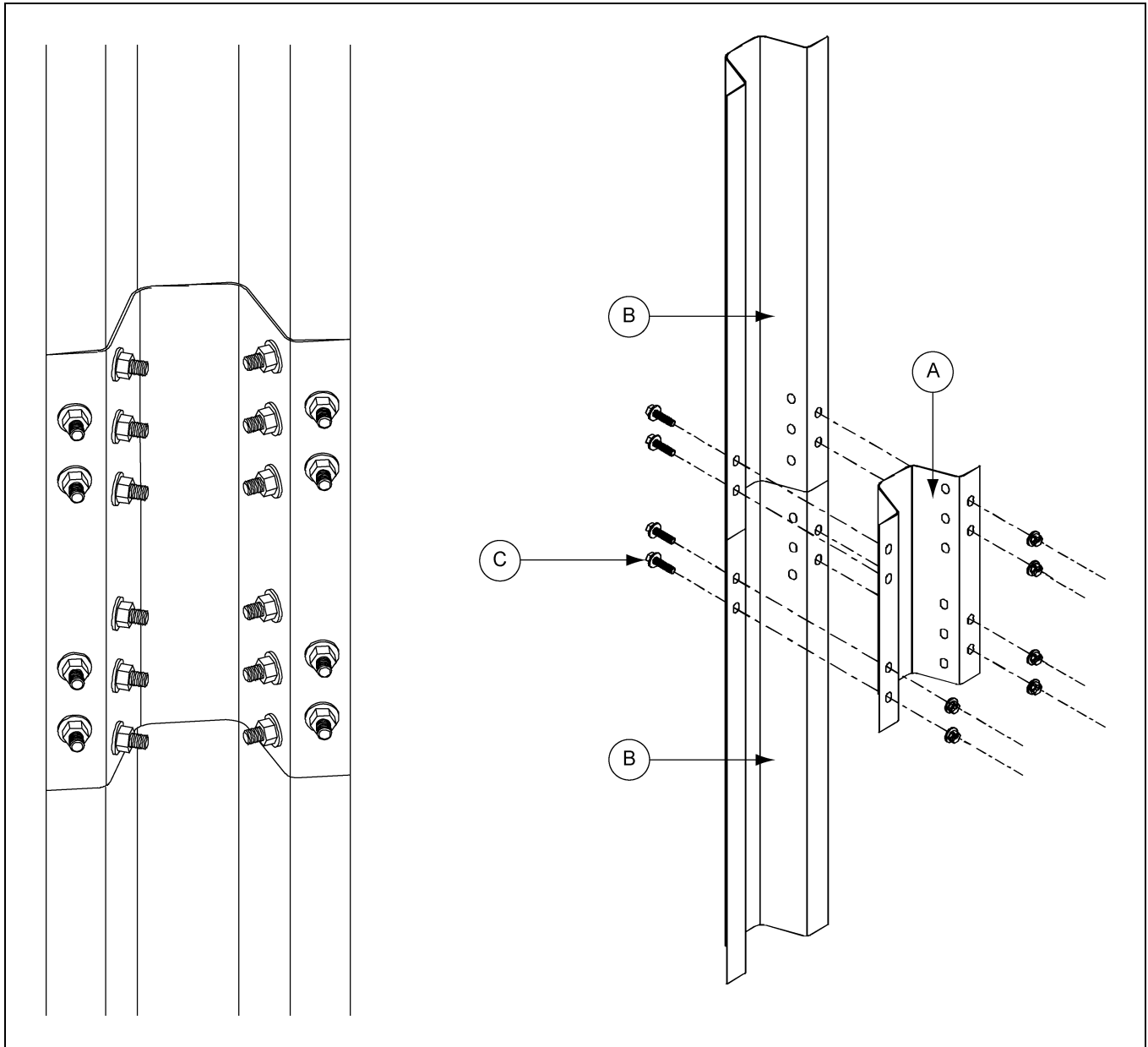

Figure 10E

Ref #	Description
A	Splice Plate 8 Gauge (SS-7053)
B	5 Gauge, 6 Gauge, 8 Gauge and 9 Gauge Standard Stiffener
C	3/8" Diameter Hex Flanged Head Bolt (No Sealing Washer)

NOTE: Install bolts in all bolt hole locations on stiffener splices.

Laminated Stiffener Splice 2.66" Corrugation

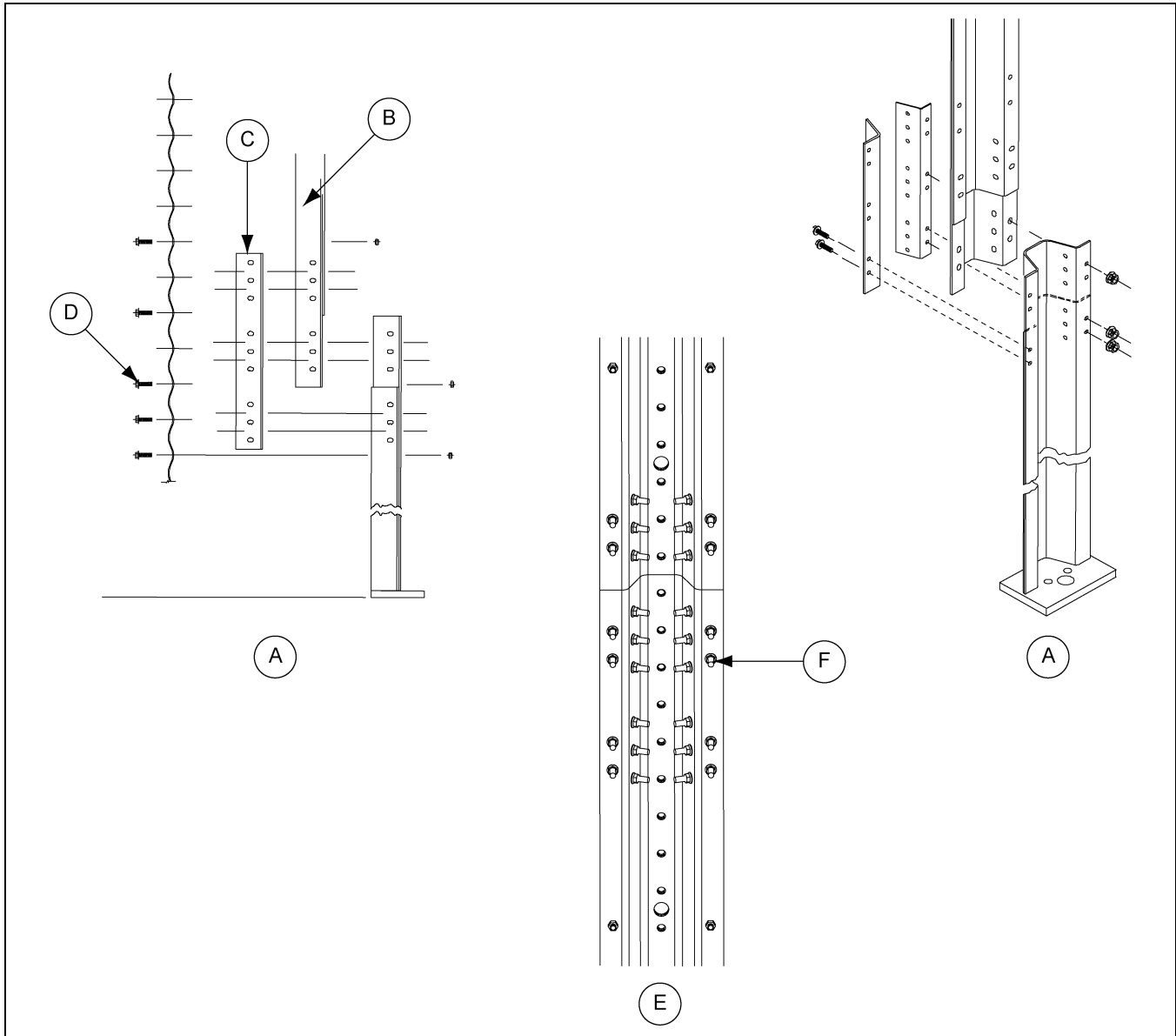

Figure 10F

Ref #	Description
A	Stiffener Detail for SS-6929
B	Laminated Stiffener Assembly (SS-6929)
C	Back Plate Splice (Two (2) per Connection) (SS-6966)
D	Use 3/8" x 1-1/2" Bin Bolt
E	Bolting detail for Laminated to Laminated Stiffener Connection
F	3/8" x 1-1/2" Flange Bolts and 3/8" Flange Nuts (30)

NOTE: Install bolts in all bolt hole locations on stiffener splices.

Laminated Stiffener Splice 2.66" Corrugation (Continued)

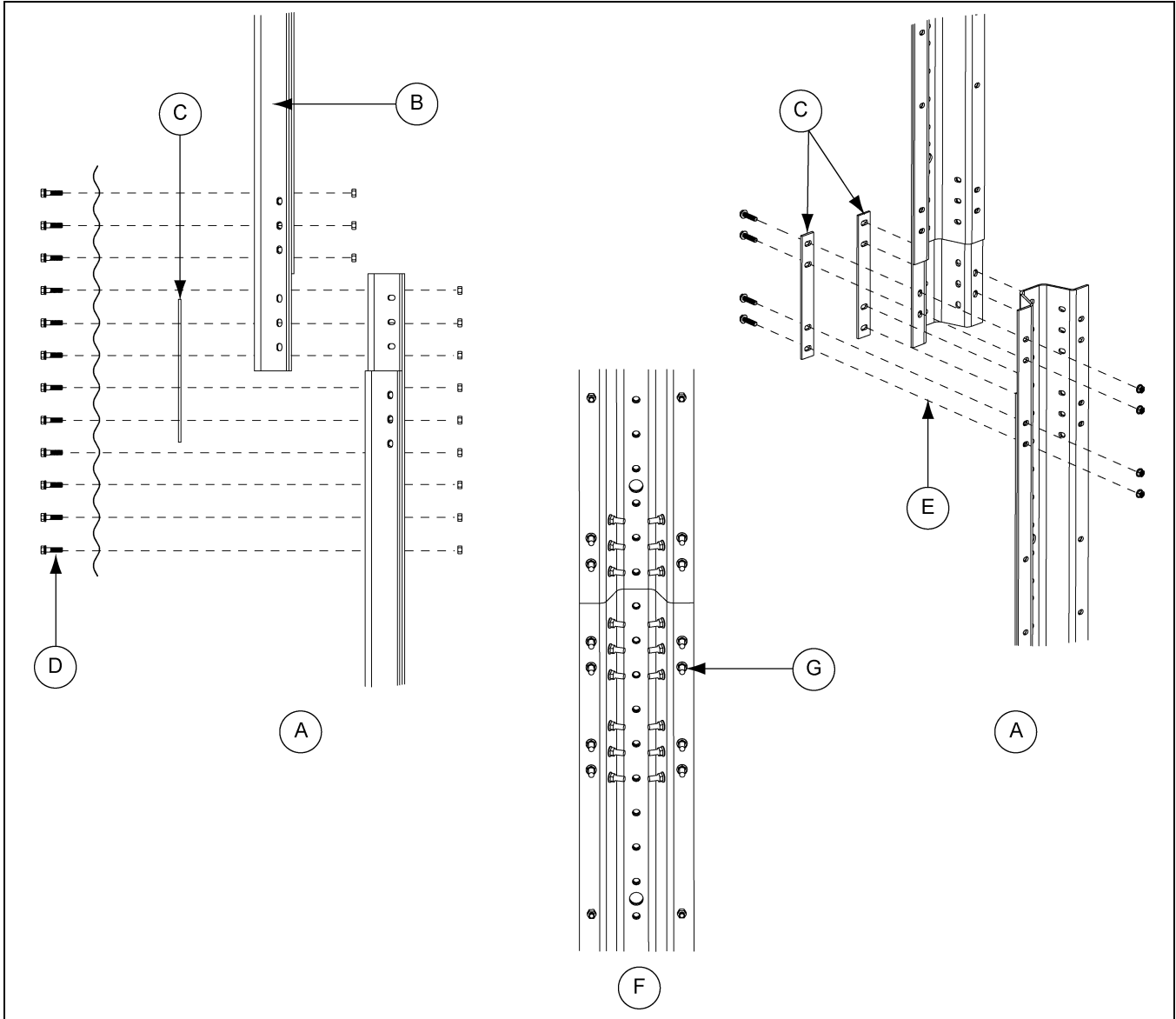

Figure 10G

Ref #	Description
A	Special Laminated Stiffener Splice Detail (SS-7427 Substituted for SS-6966)
B	Laminated Stiffener Assembly (SS-6929)
C	Laminated Stiffener Splice (SS-7427)
D	Use 3/8" x 1-1/2" Bin Bolt and 3/8" Hex Nut
E	Use 3/8" x 1-1/2" Flange Bolt and 3/8" Flange Nut
F	Bolting Detail for Laminated to Laminated Stiffener Connection
G	3/8" x 1-1/2" Flange Bolts and 3/8" Flange Nuts (30)

NOTE: Install bolts in all bolt hole locations on stiffener splices.

Laminated to Universal Stiffener Splice 2.66" Corrugation

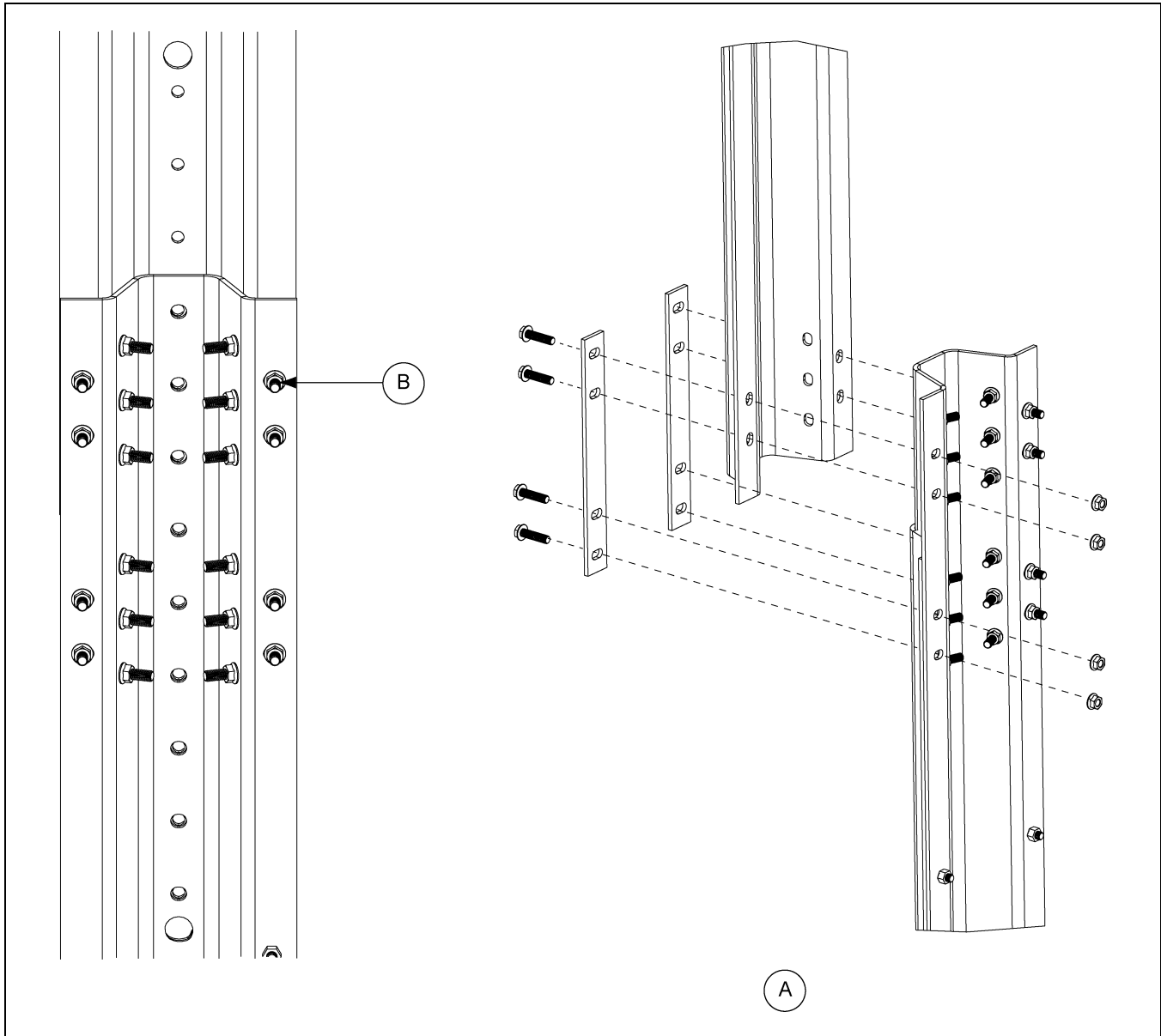

Figure 10H

Ref #	Description
A	Bolting Detail for Laminated to Universal Stiffener Connection
B	3/8" x 1-1/2" Flange Bolts and 3/8" Flange Nuts (20)

NOTE: Install bolts in all bolt hole locations on stiffener splices.

10. Stiffeners

Stiffener to Sidewall Connections 3 Post Tanks

NOTE: Use the dimensioned holes for stiffener to sidewall connections on 3 post tanks.

The same hole locations are used for 14 gauge and 15 gauge 2 ring stiffener (SS-7065).

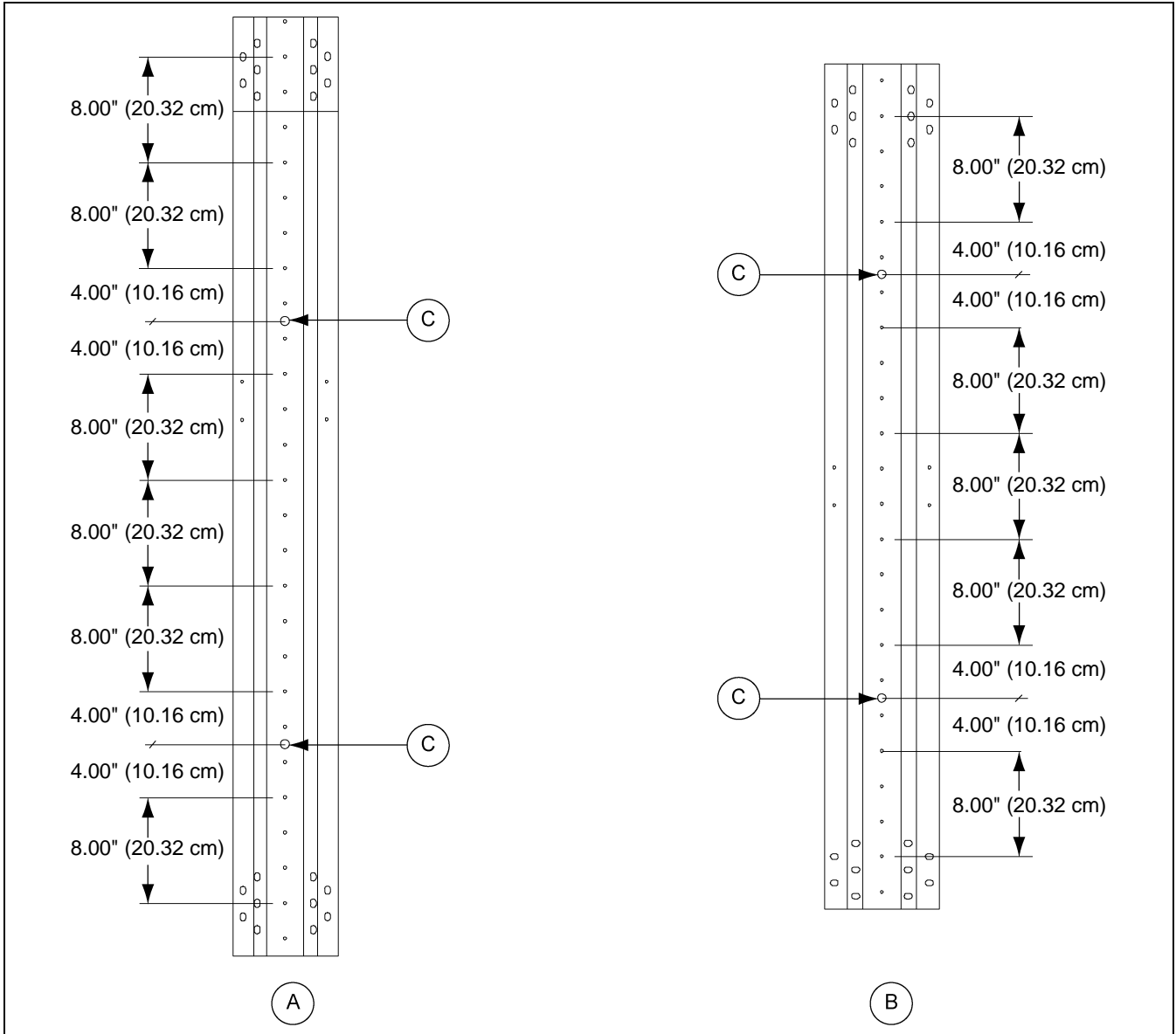

Figure 10I

Ref #	Description
A	2 Ring Offset Stiffener
B	2 Ring Standard Stiffener
C	Horizontal Seam Clearance Holes

NOTE: Some locations in the lower regions of the tank utilize close punched sheets where the stiffener will attach more frequently.

Non-Laminated Stiffener to Sidewall Detail

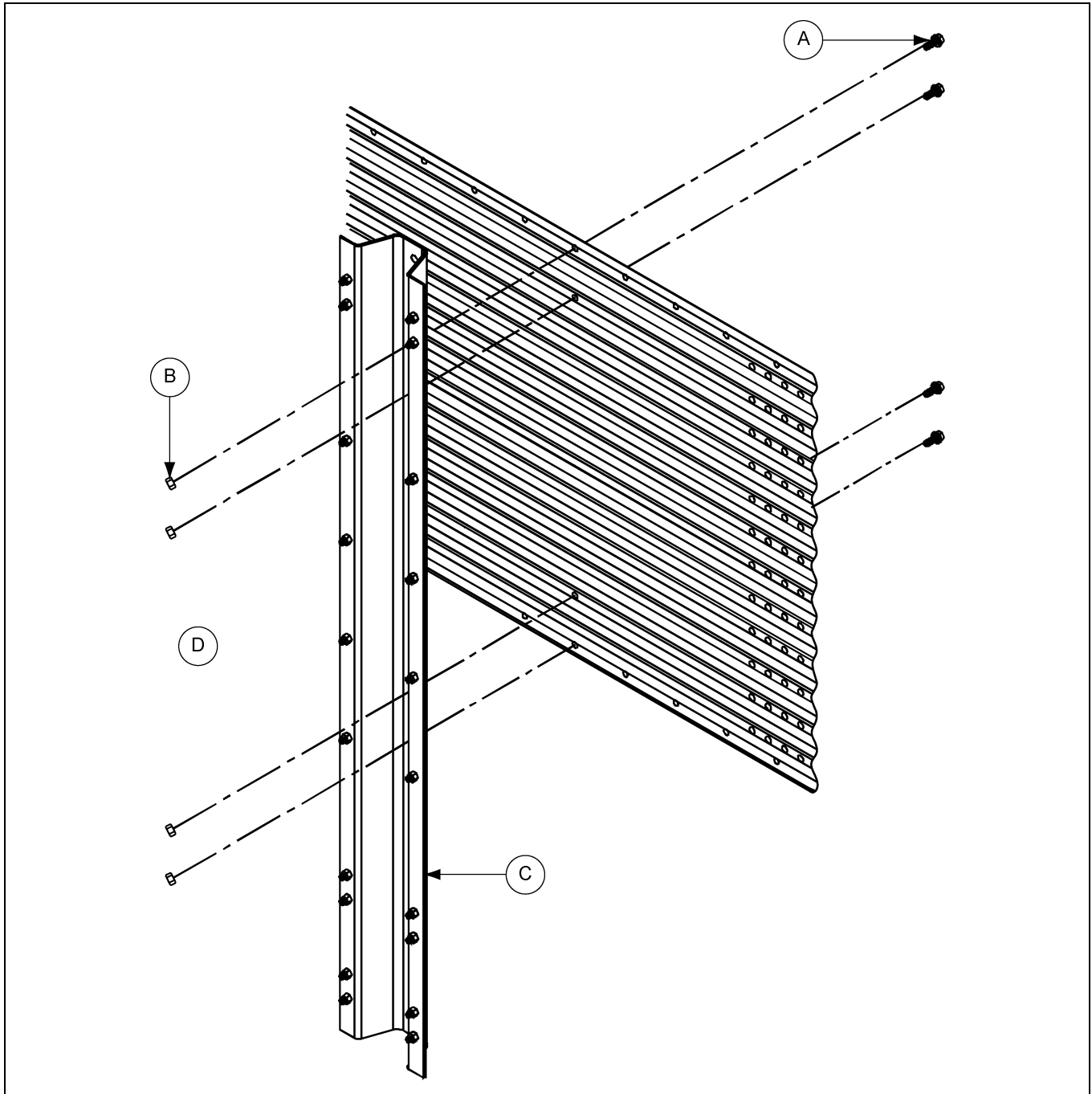

Figure 10J *Non-Laminated Stiffener to Sidewall Detail*

Ref #	Description
A	3/8" Bin Bolt with a Steel Backed Neoprene Washer
B	3/8" Nut (S-7489)
C	Non-Laminated Stiffener
D	Outside of Bin

Laminated Stiffener to Sidewall Detail

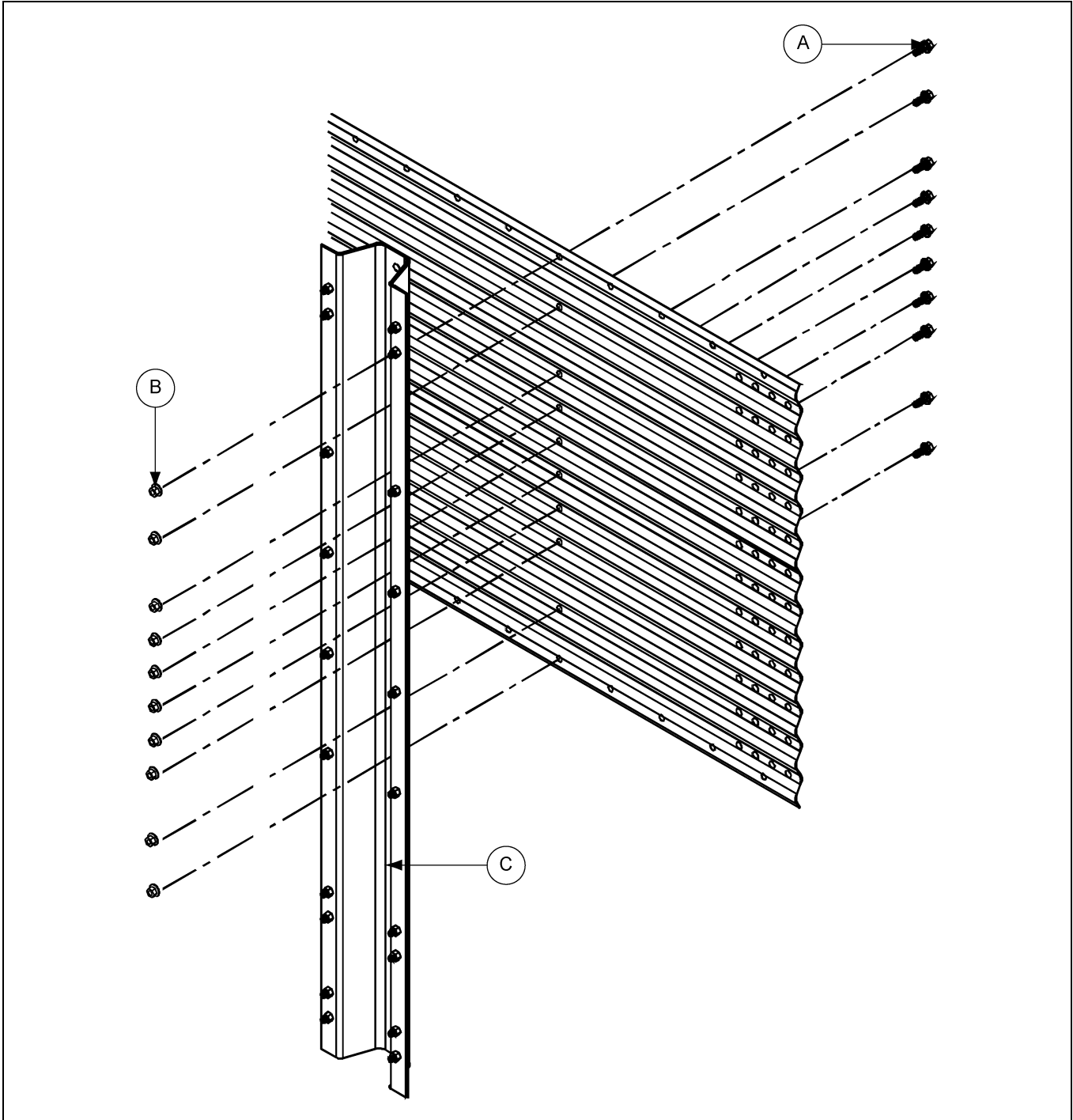

Figure 10K Laminated Stiffener to Sidewall Detail

Ref #	Description
A	3/8" Bin Bolt with a Steel Backed Neoprene Washer
B	3/8" Flange Nut
C	Laminated Stiffener

Universal Stiffener Starting Location 2.66" Reverse Corrugation Outside Stiffener Only

For sidewall to stiffener connections, use 3/8" x 1" bin bolt except horizontal seam. 19 Gauge and 20 gauge sidewall sheet will bolt four (4) locations per sheet. 18 Gauge will bolt at eight (8) locations per sheet. 17 Gauge and thicker sidewalls will bolt every 2.66".

NOTE: Splice plate and laminated stiffener to sidewall connection use 3/8" x 1-1/2" bin bolts.

Offset joints and 8 gauge splice plated joints use 3/8" x 1" hex flanged head bolts. All other stiffener joints use 3/8" x 1-1/2" hex flanged head bolts. Flanged nuts are used on the nut side of all stiffened joint connections. (See Figure 10L.)

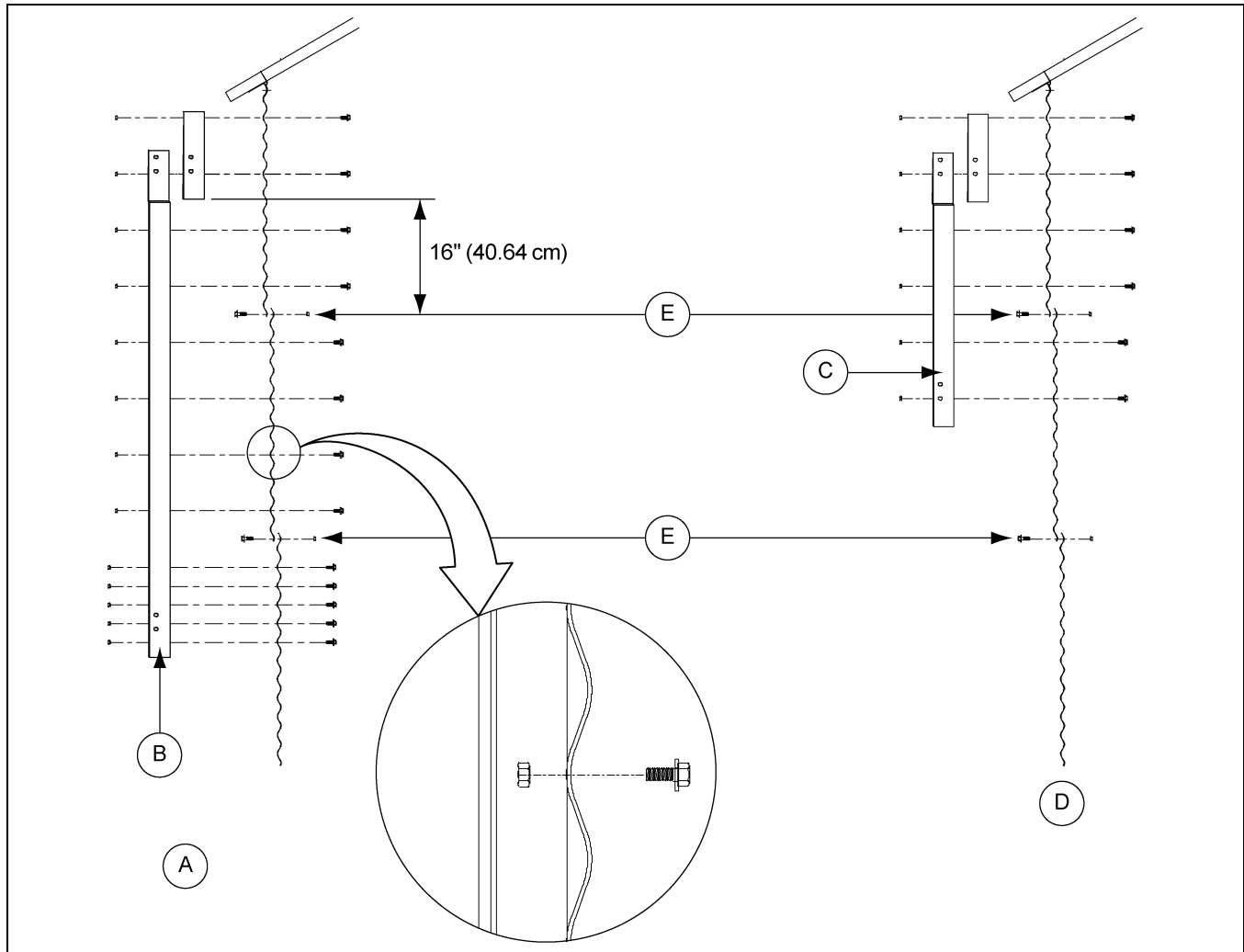

Figure 10L

Ref #	Description
A	Odd Ring Bins
B	2 Ring Offset Stiffener (SS-7065 or SS-6982)
C	1 Ring Offset Stiffener (SS-7064)
D	Even Ring Bins
E	Horizontal Seam

Wind Ring Requirements

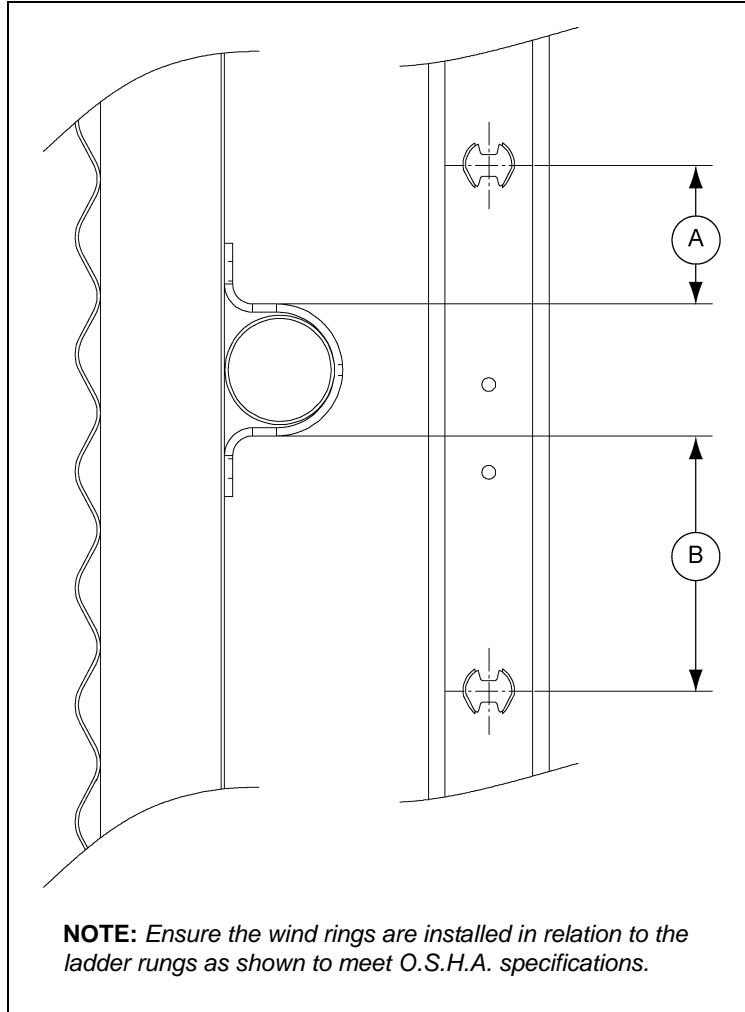

Figure 10M Dimensions for O.S.H.A. Complaint Ladder Rung Placement

Ref #	Description
A	1-1/2" (3.81 cm)
B	4-1/2" (11.43 cm)

Installing Wind Rings

Installation of wind rings is similar for a 2 and a 3 post bin design, although hardware quantities may vary.

What You Should Know

Before installing, determine the bin size, sidewall gauge thickness and height. Use the hardware chart to match the correct bolt length with the correct sidewall gauge thickness when installing the wind ring brackets to the stiffeners. (Refer to hardware requirements chapter [on Page 46.](#)) To determine the location of the wind rings or if additional wind rings will be needed for sidedraw systems, see wind ring requirements for sidedraw systems.

Installing Wind Rings (Continued)

1. Install a wind ring bracket (B) to each stiffener (C) using flange bolts (A) and flange nuts (D).

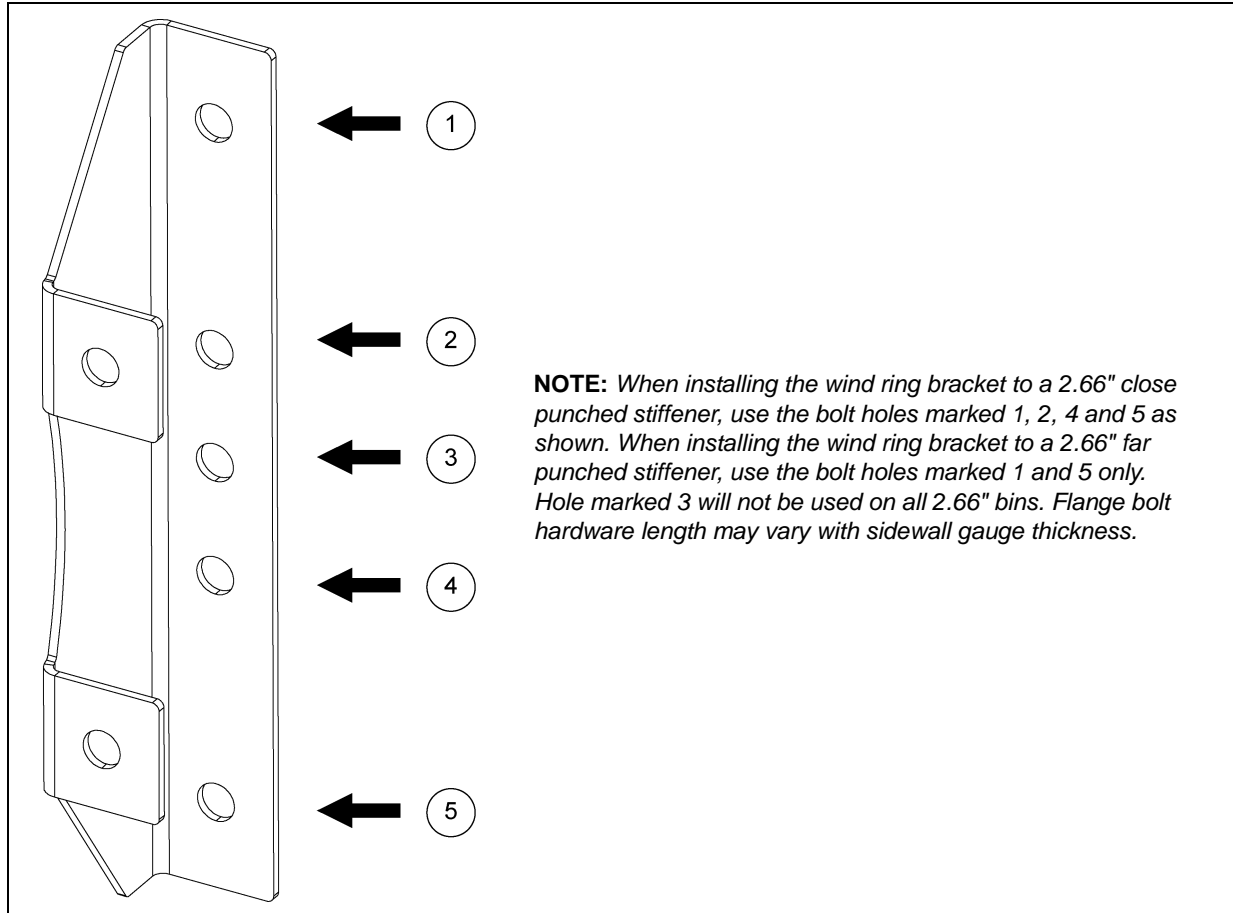

Figure 10N Wind Ring Bracket

2. Tighten hardware to the recommended torque specifications. See bolt torque specifications [on Page 46](#).
3. Place a wind ring section (E) into the channel of the wind ring bracket (B) and install a C-clamp (I), securing with flange bolts (H) and flange nuts (J). Do not tighten until all wind ring sections are installed.
4. Repeat this procedure, inserting each wind ring section (E), over the previously installed wind ring section, securing the wind ring sections together with flange bolts (F) and hex nuts (G).
5. Before installing the last wind ring section (E), slide a wind ring coupling collar (K) over the wind ring section (E).
6. Install the last wind ring section (E) and cut the wind ring section to the proper length.

NOTE: The cut needs to be made in a location that allows minimal space between the pipes.
7. Slide the wind ring coupling collar (K), aligning the three (3) pre-drilled holes and install flange bolts (F) and hex nuts (G). Field drill the remaining three (3) holes (L) using the wind ring coupling collar (K) as a guide or template. ([See Figure 10O on Page 68.](#))
8. Install the remaining flange bolts (F) and hex nuts (G) and tighten all hardware to the recommended torque specifications. See bolt torque specifications [on Page 46](#).

10. Stiffeners

Installing Wind Rings (Continued)

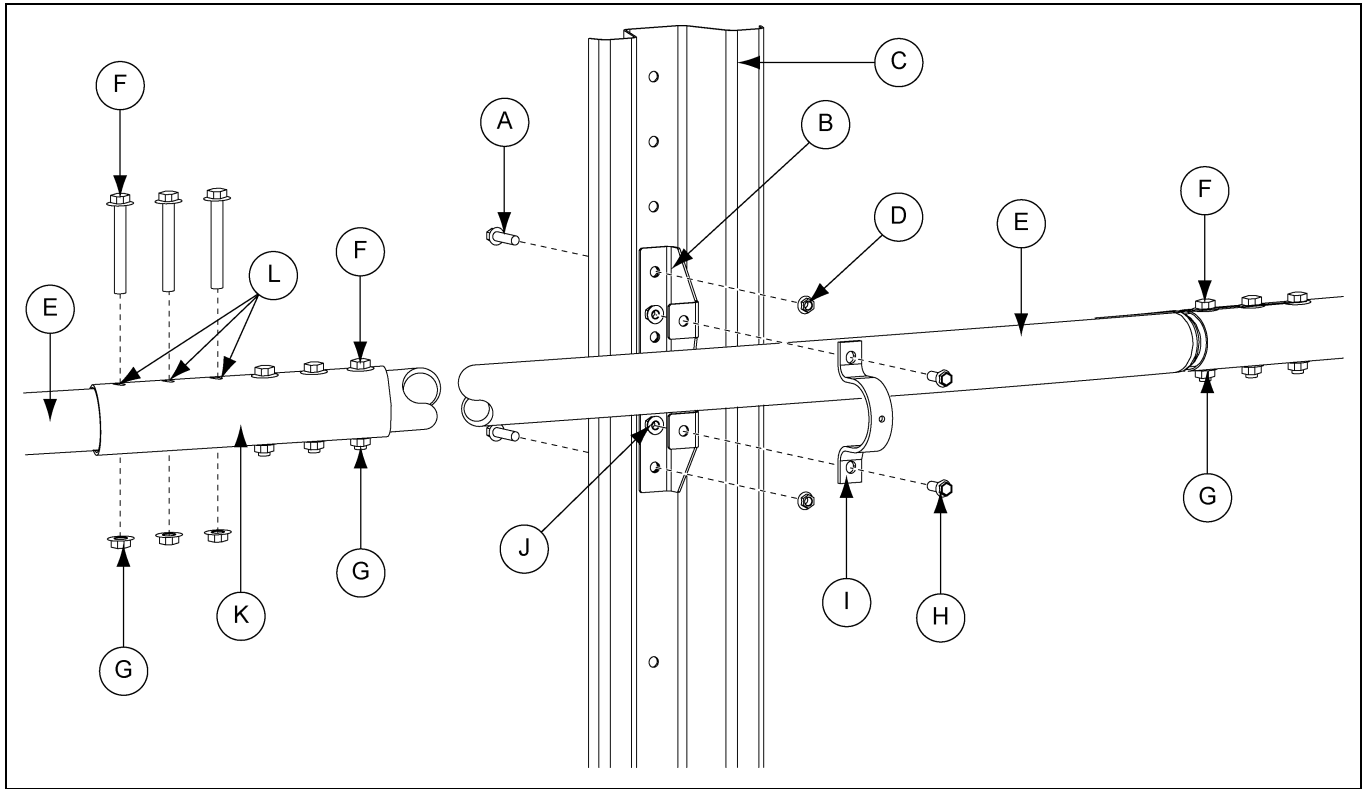

Figure 100 Exploded View of Wind Ring Installed at Upper Portion of Stiffener

Ref #	Part #	Description
A	Varies	Flange Bolt with Sealing Washer
B	CTS-1005	Wind Ring Bracket
C	Varies	Stiffener
D	Varies	Flange Nut
E	CTS-1004-XX (or) CTS-1002-XX	Wind Ring Section
F	S-10261	Flange Bolt 7/16"-14 x 3-1/4" JS Grade 8.2 with Sealing Washer
G	S-9281	Hex Nut 7/16"-14 JS Grade 5
H	S-7485	Flange Bolt 3/8"-16 x 1" JS Grade 8 or Grade 8.2
I	SS-7248	C-Clamp
J	S-9426	Flange Nut 3/8"-16 JS
K	CTS-1006	Wind Ring Coupling Collar
L		Field Drilled Hole Location

NOTE: (-XX) denotes the bin diameter.

Stiffener Shim Plate Detail (Use when Necessary)

The shim plates (A) should be used where necessary to ensure the base plates are firmly supported by the columns. Use the shim plates (A) to fill any gaps between the base plate and the compression weldment. Refer to [Figure 10P](#). Attach the base stiffener to the stiffener column and compression weldment with 5/8" x 2-3/4" bolts (two (2) per stiffener). Place a washer on the top side of the stiffener base plate.

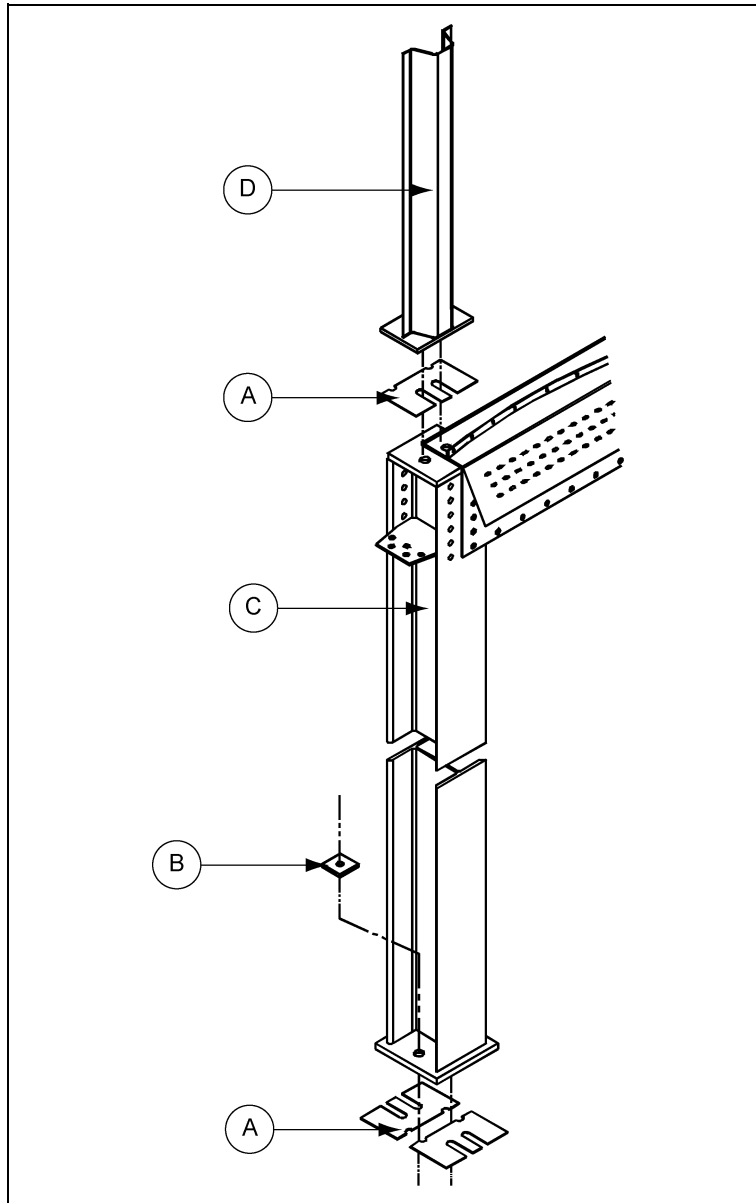

Figure 10P

Ref #	Part #	Description
A	CHT-1160	Shim Plate
B	HT-635	Square Washer for 3/4" Anchor Bolt
C		Column Weldment
D		Base Stiffener Weldment

11. Flashing Instructions (Optional)

1. Attach flashing (A) to the bin wall using the pre-punched holes at 9-1/3" above the horizontal seam.
2. Attach left side of the first piece of flashing (A) to the sidewall using the connection as shown in [Figure 11A](#). Working clockwise, overlap the flashing (A) at the right hand hole of each piece of flashing. **NOTE:** *If bolts are installed at flashing seam location they will need to be removed.*
3. At vertical seams attach flashing (A) that is to span the vertical seams using both left and right holes. Drill flashing holes from the outside of the bin through the sidewall sheet (E) holes. Remove drilled flashing (A) and assemble vertical seam bolts and nuts (C and D). ([See Figure 11C on Page 71.](#)) Replace drilled flashing (A) and attach according to [Figure 11B](#). Continue around the bin clockwise.

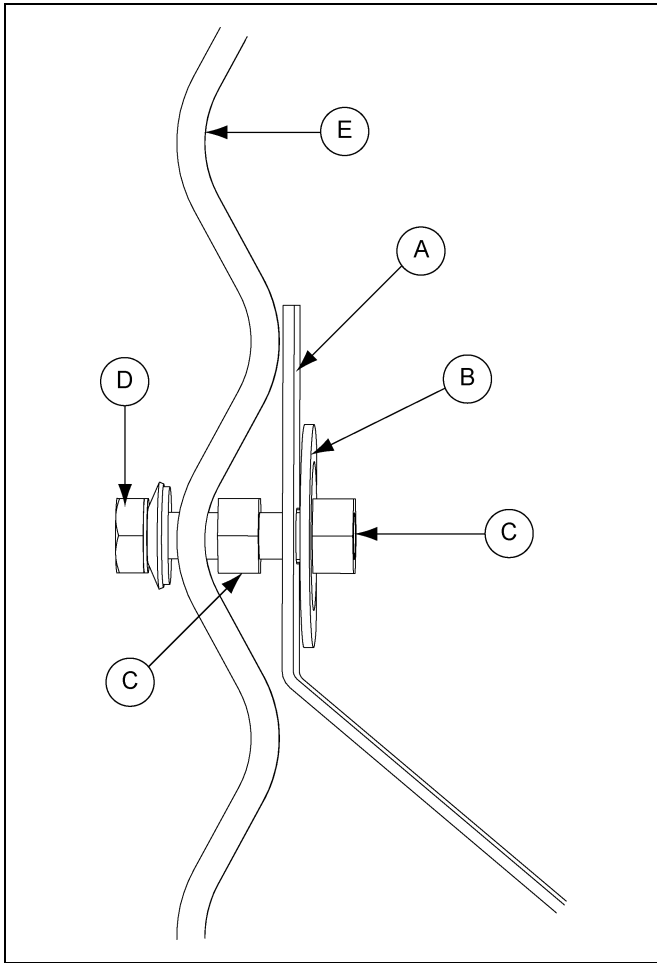

Figure 11A Flashing Hardware

Hardware Configuration for Flashing Installation

Ref #	Part #	Description
A	CHT-2104	Flashing
B	S-7569	5/16" Fender Washer
C	S-10268	5/16" Hex Nut
D	S-7483	5/16" x 1-1/4" Bin Bolt
E		Sidewall Sheet

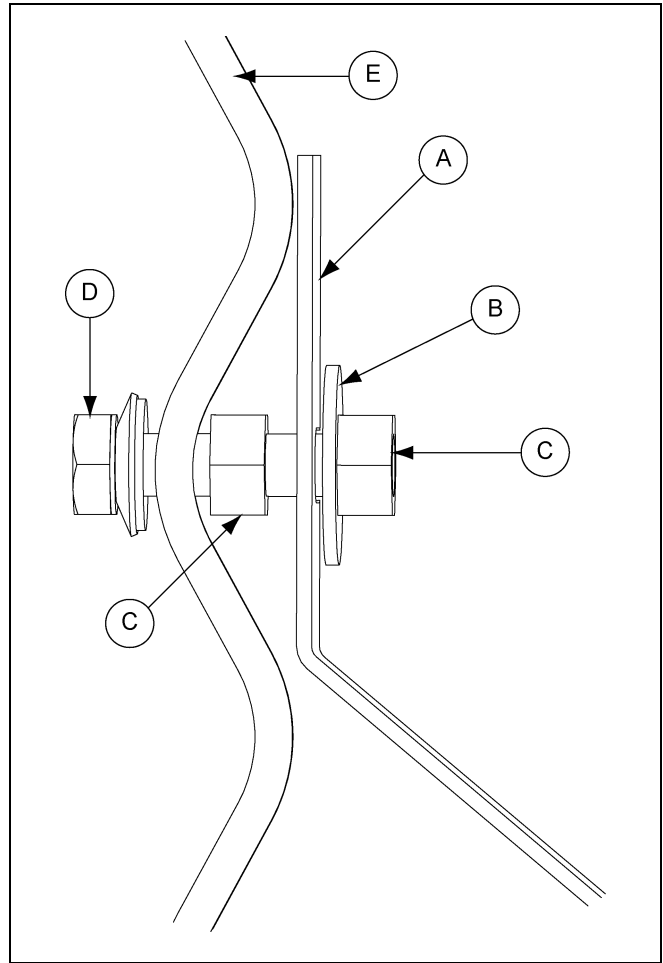

Figure 11B Vertical Seam Flashing Hardware

Hardware Configuration for Flashing Installation at Vertical Seams

Ref #	Part #	Description
A	CHT-2104	Flashing
B	S-248	3/8" Washer
C	S-10268	5/16" Hex Nut
D	S-7483	5/16" x 1-1/4" Bin Bolt
E		Sidewall Sheet

NOTE: *Only difference between normal hardware configuration and vertical seam hardware configuration is washer.*

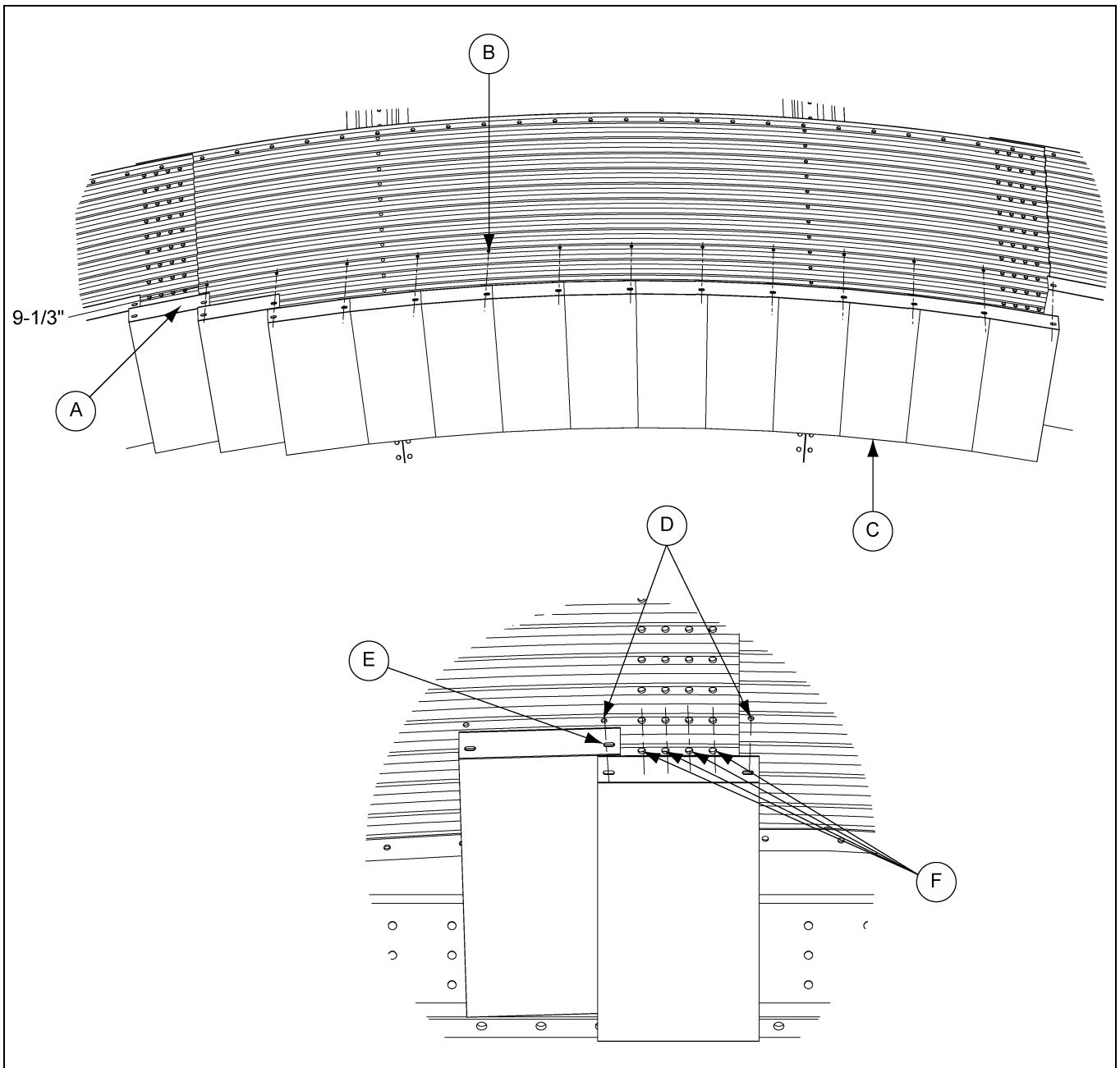

Figure 11C

Ref #	Description
A	Overlap flashing at right hand hole. Work clockwise when installing flashing.
B	Pre-Punched Holes
C	Flashing (CHT-2104)
D	Attach flashing here to drill holes.
E	Attach flashing to span vertical seam at both left and right hand holes. Drill flashing holes from outside of bin through vertical seam holes.
F	Drill holes through flashing.

Access Door Weldment Assembly Hardware Package (PLS-41985)

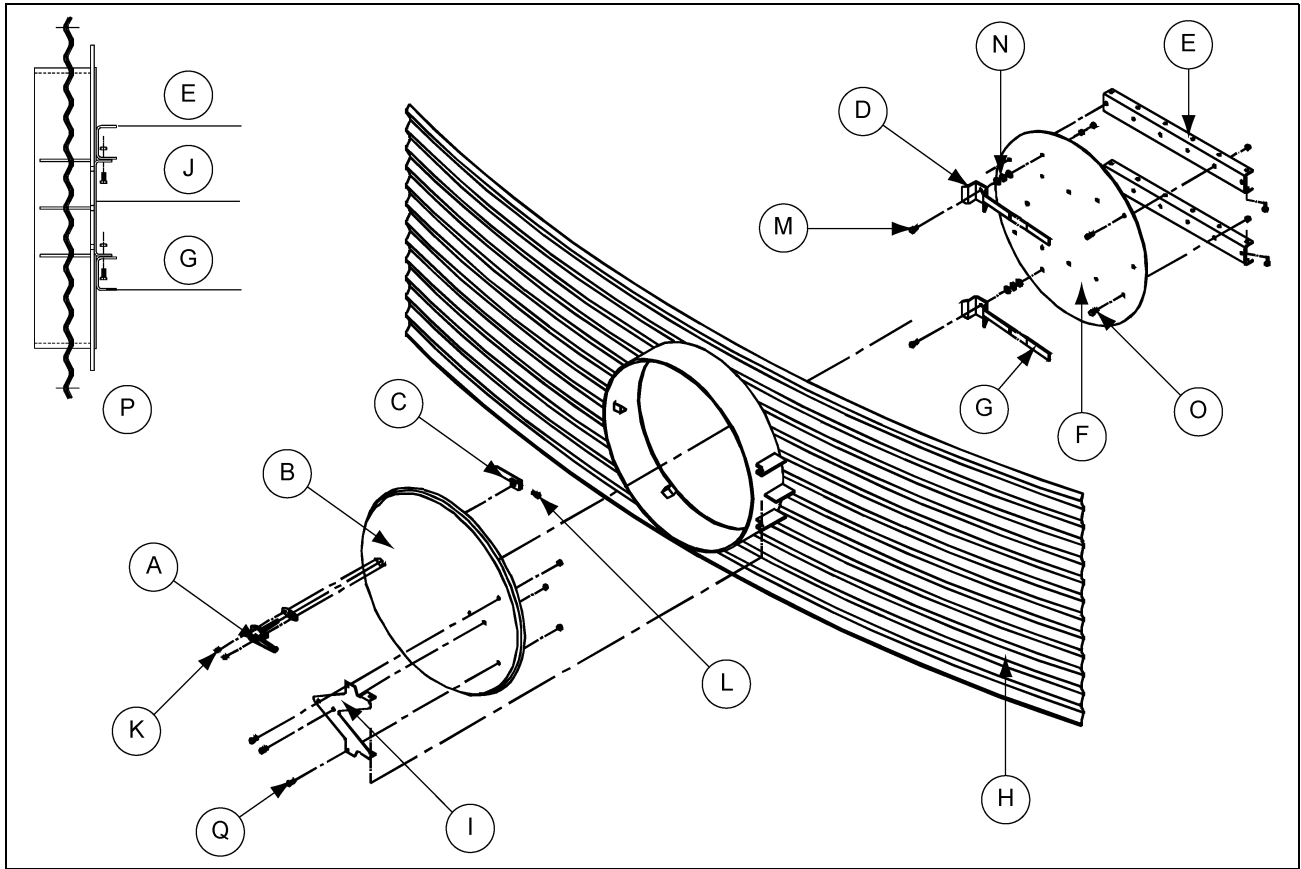

Figure 12A

Ref #	Part #	Description
A	ACD-4513	Access Door Handle
B	ACD-4531	Door Cover
C	ACD-4514	Latch Bar
D	ACD-4515	Access Inner Door Handle (2)
E	ACD-4549	Bottom Ring Inner Door Hinge (2)
F	ACD-4548	Inner Door
G	S-3867	Sleeve, Plastic RD Door Handle (2)
H	SS-7211 and SS-7214	Access Door Weldment
I	ACD-4505	Access Door Hinge
J	ACD-4509	Access Inner Door Hinge Bracket
K		#10 Screw
L		5/16" x 1" Bolt and Nut
M		3/8" x 1-1/2" Full Threads
N		** 3/8" Washers (Use as Needed)
O		3/8" x 1" Bolt
P		Assembled Side Detail
Q		5/16" x 1" Bolt

** The quantity of 3/8" washers needed may vary depending on the sidewall gauges.

Aeration Package (Optional)

- Step 1:** Using reinforcing plate as a template, mark hole in hopper for cutting.
- Step 2:** Using a torch or saw, cut the hole in hopper sheets for tube.
- Step 3:** Remove enough bolts from hopper seam to allow reinforcing plate to set down on hopper panels.
- Step 4:** Install reinforcing plate on inside of hopper (and outside for 27' and 30' tanks). Full weld and field drill holes and bolt in place. Drill holes through reinforcing plate where it overlaps holes in seam and reinstall bolts.
- Step 5:** Install torpedo head at open end of tube and screw in place as shown (screws not included).
- Step 6:** Four (4) angles with corrugated pieces welded on them are supplied for each tube (two (2) per side). Bolt or weld each angle to the hopper sheet and screw or weld the corrugated material to the perforated tube (#14 x 1" self-drilling tek screws not provided).
- Step 7:** Full weld inside and outside around perimeter of aeration tube saddle 'tee'.
- Step 8:** Bolt or weld on angle ring for attachment of fan.
- Step 9:** Touch up any welded areas with a rust inhibitive type paint.

NOTE: *When two (2) tubes are installed, second tube is to be installed 180° from first tube.*

Aeration Package (Optional) (Continued)

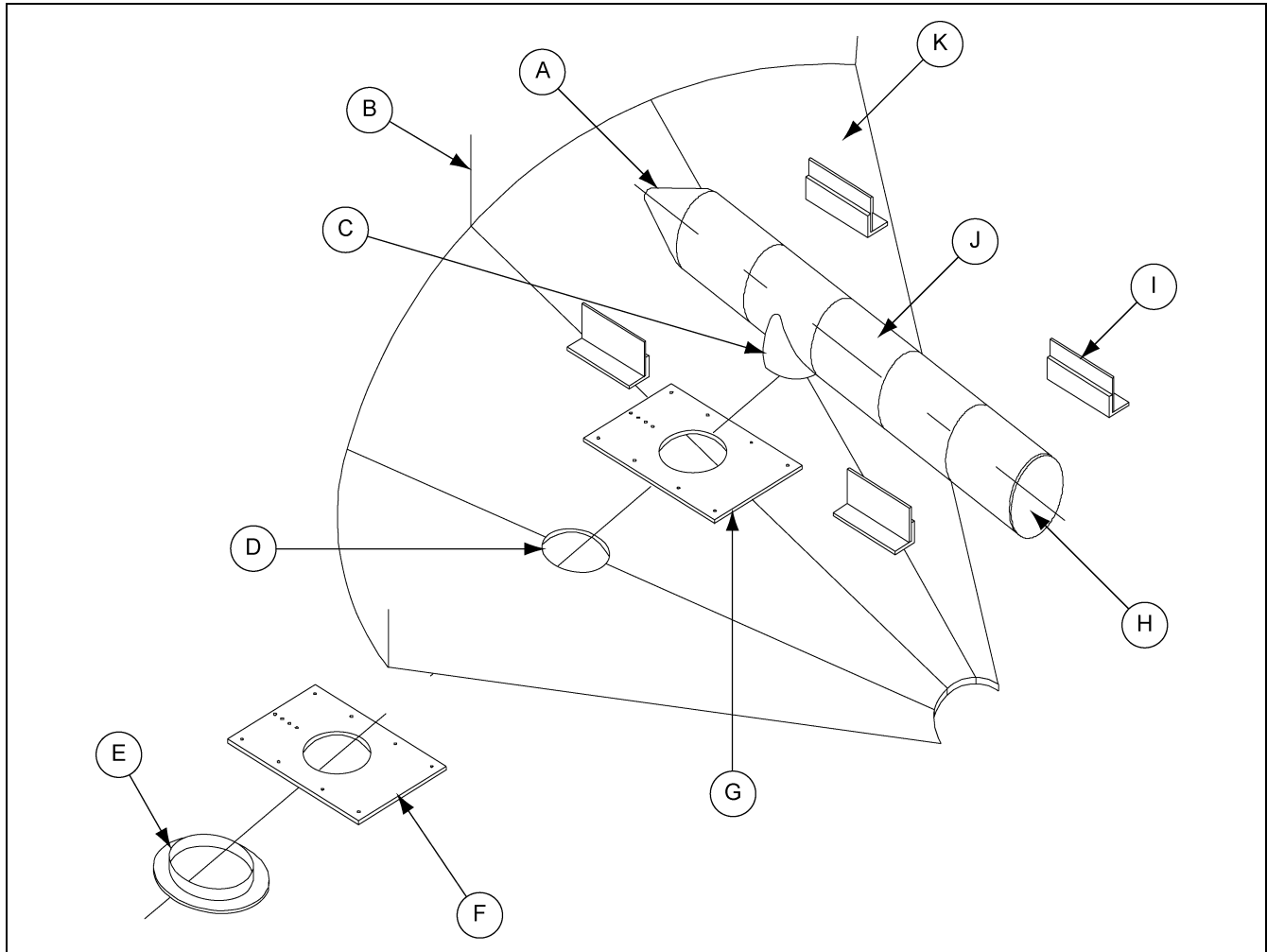

Figure 13A Typical Installation

Ref #	Description
A	Torpedo Head
B	Stiffener
C	Saddle 'Tee'
D	Center tube(s) over a seam between two (2) columns, mark location of saddle 'tee' and field cut a 18-7/8" diameter hole centered on seam. Remove enough seam bolts to allow installation of the reinforcement plate.
E	18" Angle ring (F-895) not included in package (bolt or weld to saddle 'tee' after tube installation)
F	Reinforcement plate (24" x 36") (required only on 27' and 30' tanks) bolt and full weld to hopper. (Field drill and replace all seam bolts.)
G	Reinforcement plate (24" x 36") bolt and full weld to hopper. (Field drill and replace all seam bolts.)
H	Perforated End Cap/Heavy Duty "X" Brace
I	Hold-Down (Typical)
J	Corrugated, Perforated Tube (18" Diameter Standard)
K	Bin Hopper

Aeration Package (Optional) (Continued)

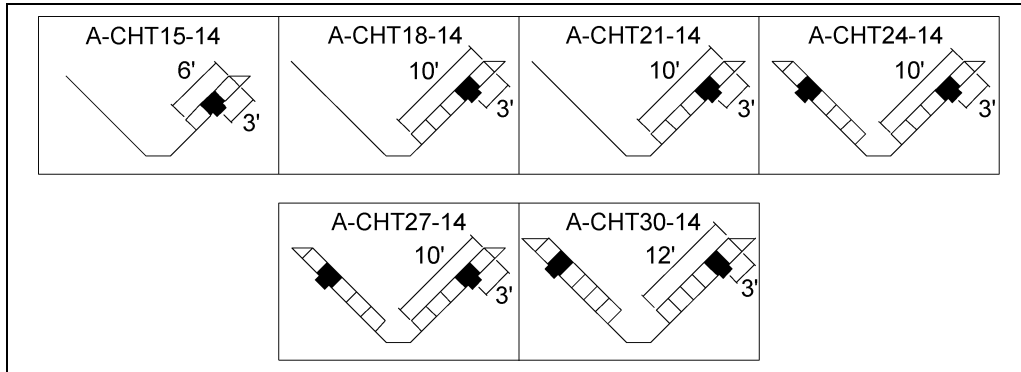

Figure 13B

System	Airflow Rating (CFM)
A-CHT15-14	1209
A-CHT18-14	2016
A-CHT21-14	2016

System	Airflow Rating (CFM)
A-CHT24-14	4032
A-CHT27-14	4032
A-CHT30-14	4838

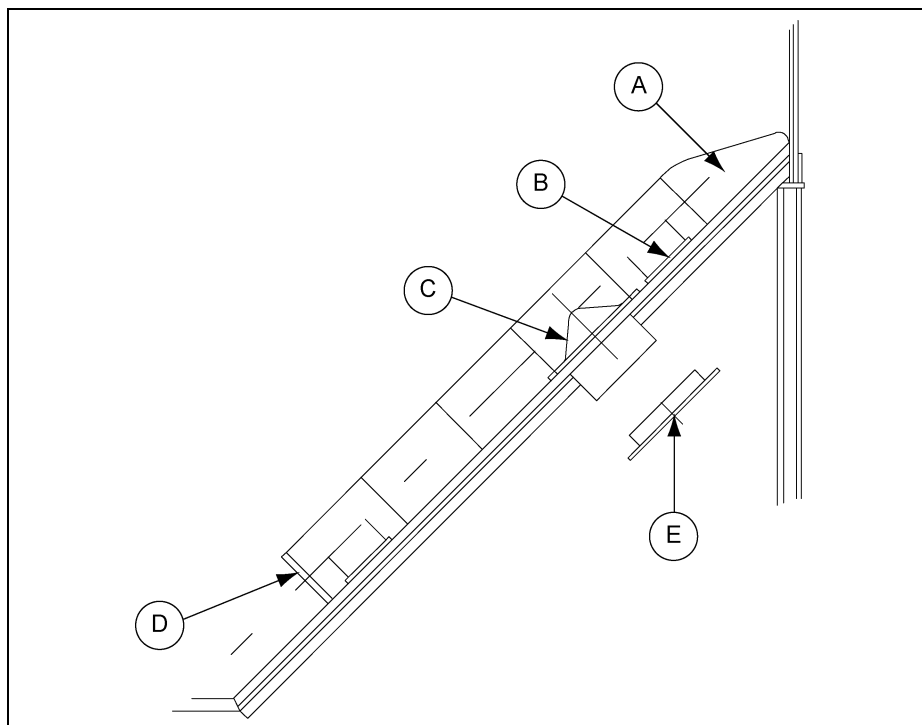

Figure 13C Typical Profile

Ref #	Description
A	Torpedo Head
B	Hold-Down
C	Saddle 'Tee'
D	Perforated End Cap/Heavy Duty "X" Brace
E	18" Angle ring (F-895) not included in package (bolt or weld to saddle 'tee').

Aeration Package (Optional) (Continued)

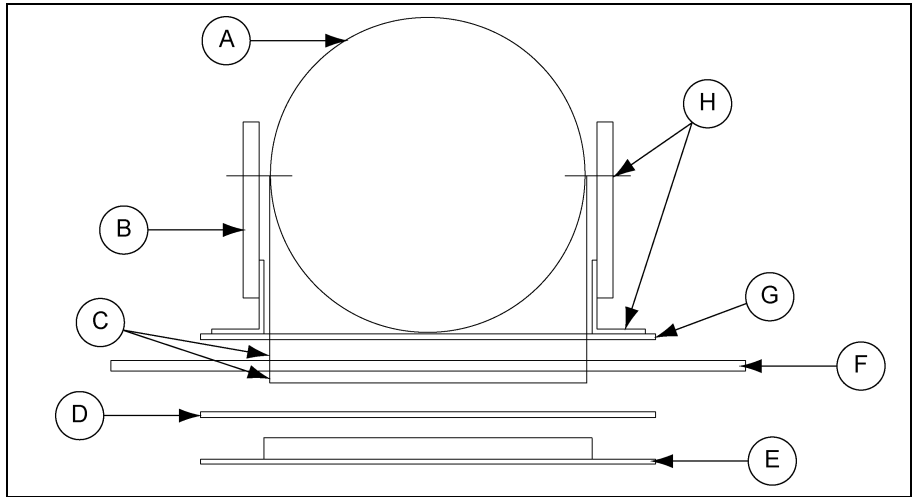

Figure 13D Weld Detail

Ref #	Description
A	Aeration Tube
B	Corrugated Angle Sections (Two (2) per Side)
C	Weld All Around
D	Second reinforcement plate required on 27' and 30' tanks.
E	18" Angle ring (F-895) not included in package. (Bolt or weld to saddle 'tee' after tube installation.)
F	Hopper Sheet
G	Reinforcement Plate (24" x 36")
H	Bolt or weld to hopper sheet and screw or weld to aeration tube.

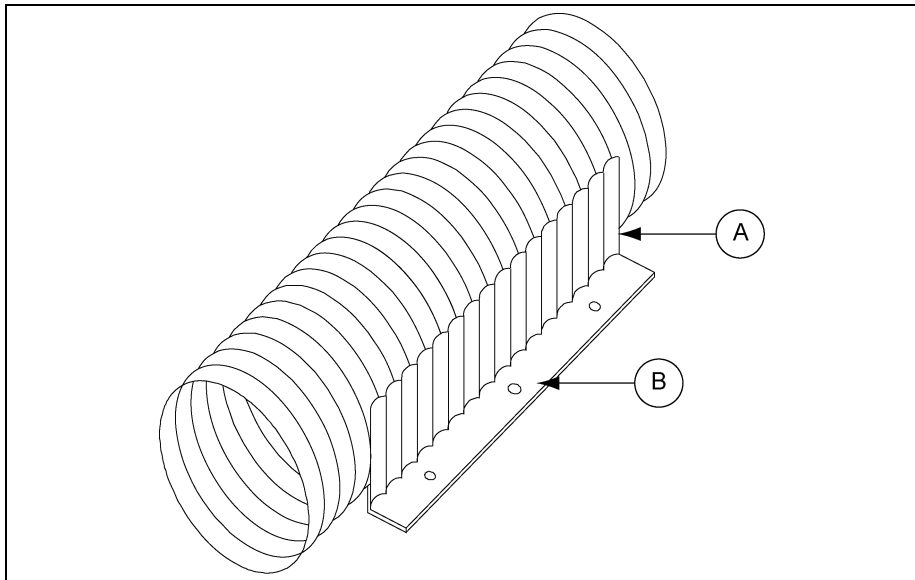

Figure 13E Corrugated Angle Hold-Down Attachment Detail

Ref #	Description
A	Screw or Weld to Tube (Screws: #14 x 1" Self-Drilling Tek Screws - Not Provided)
B	Weld to Hopper of Bolt with 9/16" Bolts (Field Drill and Replace All Seam Bolts)

Ladder Support Detail

The ladder (A) must be secured to the hopper support columns (C) with ladder standoff brackets (F) using support channels (D) and ladder brackets (E) as shown in *Figure 14A*.

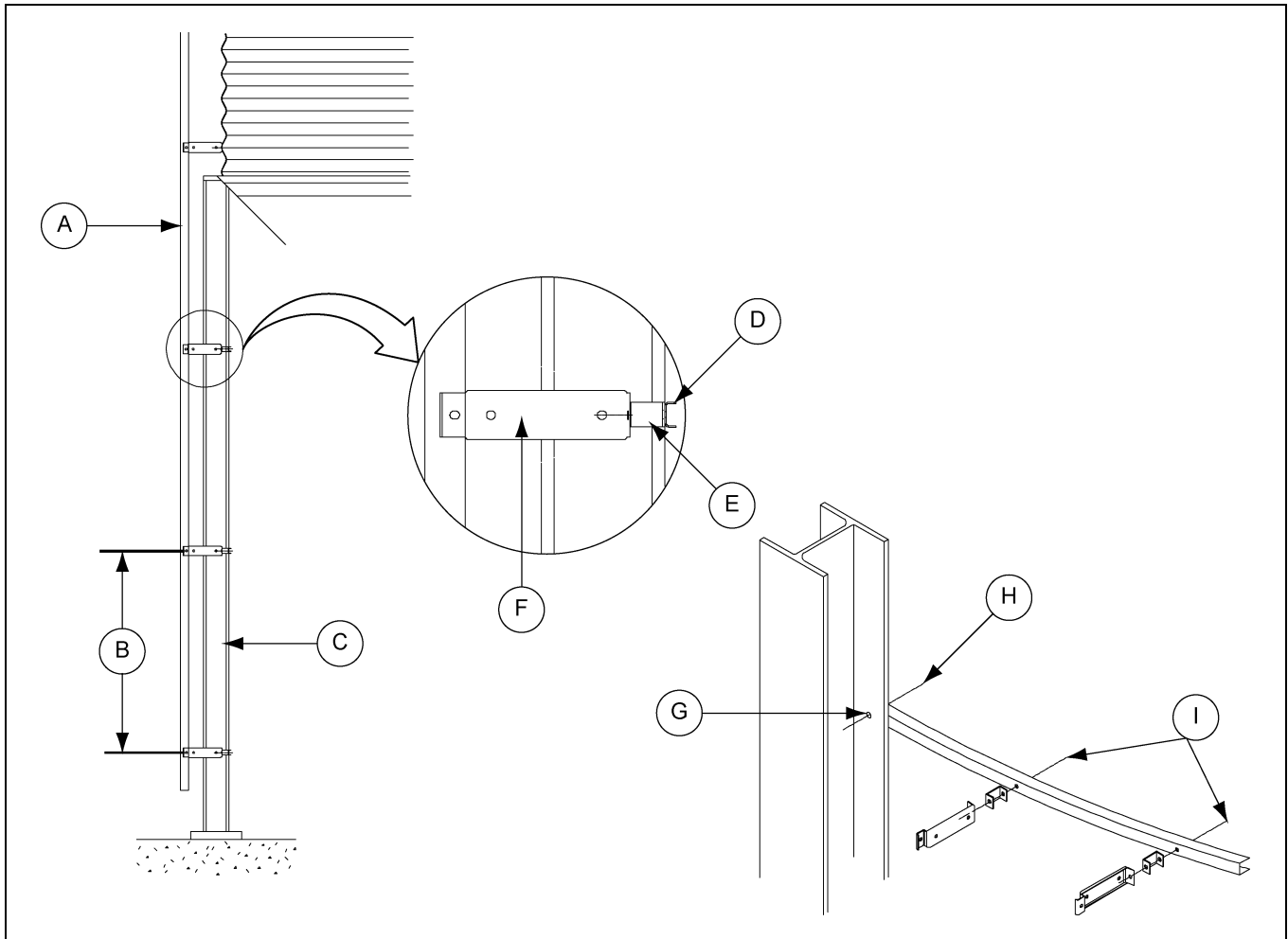

Figure 14A

Ref #	Description
A	Ladder
B	32" Typ.
C	Support Column
D	Support Channel (CHT-1594)
E	Ladder Bracket (CHT-1233)
F	Ladder Standoff Bracket (LDR-4314)
G	Field Drill 3/8" Hole or Weld to Column
H	5/16" x 1-1/4" Hardware
I	5/16" x 1" Hardware

14. Ladders

Ladder Support Detail (Continued)

Tank Diameter	Hopper Slope	# of Support Channels	Hopper Ladder Brackets
12'	45	3	6
12'	60	4	8
15'	45	4	8
15'	60	6	12
18'	45	4	8
18'	60	7	14
21'	45	5	10
21'	60	8	16
24'	45	5	10
27'	40	5	10
30'	40	5	10
36'	40	6	12
36'	45	8	16

Hoist Instructions

Recommendations for hoisting completed tank onto hopper bottom structure.

(All parts mentioned in this section are **not** furnished.)

A crane is normally used to lift the tank and place it on top of the substructure. Technique of hoisting of the complete tank on the hopper structure is in large part based on personal experience, equipment and manpower. The following recommendations are intended as a guideline only.

1. Before lifting the tank, the following should be checked:
 - a. The columns and substructure should be checked for levelness and verified plumb and leveled if necessary.
 - b. Final ladder and safety cage and door locations should be determined and clearance at these locations verified.
 - c. Proper provisions should be made for safe working platforms around the top of the substructure.
2. Lifting techniques are largely influenced by personal experience and equipment capacity, however general recommendations as follows:
 - a. Lifting brackets should be attached to the stiffeners. At least one bracket per sidewall sheet should be used. These are usually attached in the third ring from the bottom of the tank. Brackets should attach to a minimum of four (4) bolts through the stiffener. Attach cables to the lift brackets and to the crane hook, which has been lowered through the center ring opening. Cables should be sized to handle the entire weight of the bin. Make all lift cables of equal length before the bin is lifted. Refer to [Figure 15A](#) and [Figure 15B on Page 80](#).
 - b. To prevent distortion of the assembled tank, a “spider” or horizontal bracing is recommended. A suggested method of this is illustrated in the following details. This may be done by using a center “hub” and pipe. The center hub is made of 6" schedule 40 pipe with 3" x 3" x 3/8" angle welded to it and the pipe bolting to the hub. The second smaller pipe will bolt to the lifting brackets attached to the stiffeners. (Refer to [Figure 15C on Page 81](#).) Typical number of horizontal members that should be used are shown in the chart below.
 - c. Use of temporary bracing across the peak collar may be needed to guide the cable. This should be made easily removable.

Recommended Minimum Number of Lift Brackets	
Diameter	# of Brackets
12'	4
15'	5
18'	6
21'	7
24'	8
27'	9
30'	10

Recommended Number of Horizontal Brackets	
Diameter	# of Braces
21'	3
27'	3
12'	4
24'	4
15'	5
30'	5

Hoist Instructions (Continued)

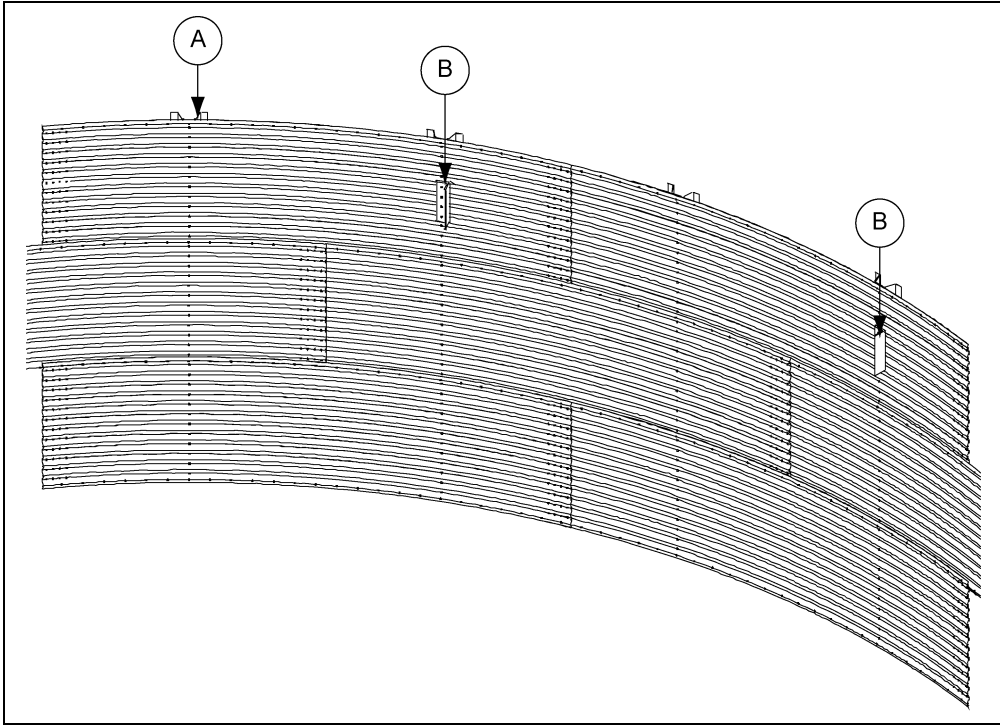

Figure 15A

Ref #	Description
A	Stiffener
B	Lift Bracket Every Other Stiffener

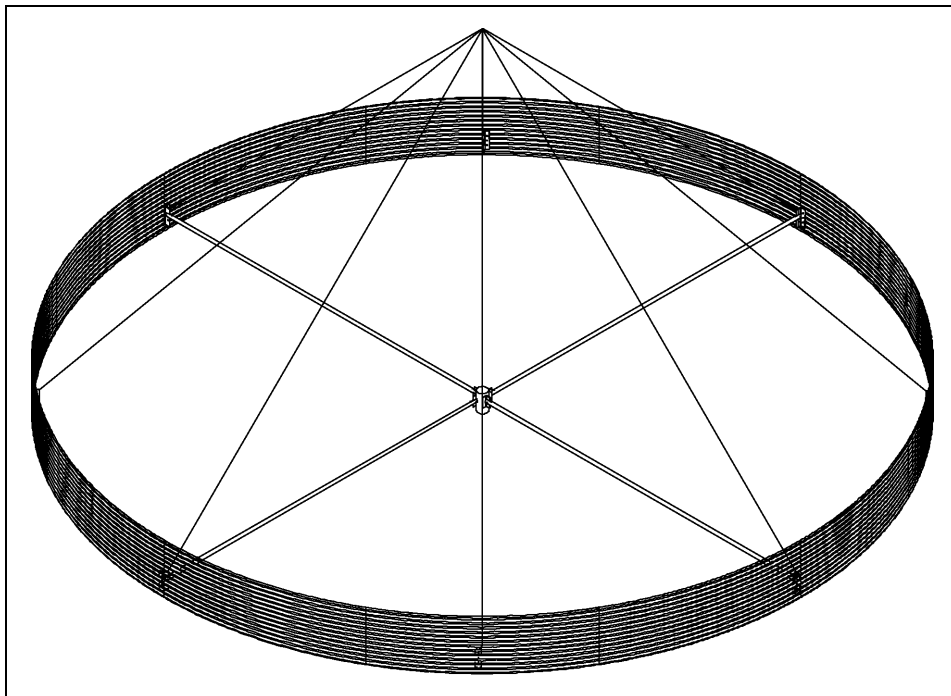

Figure 15B

Hoist Instructions (Continued)

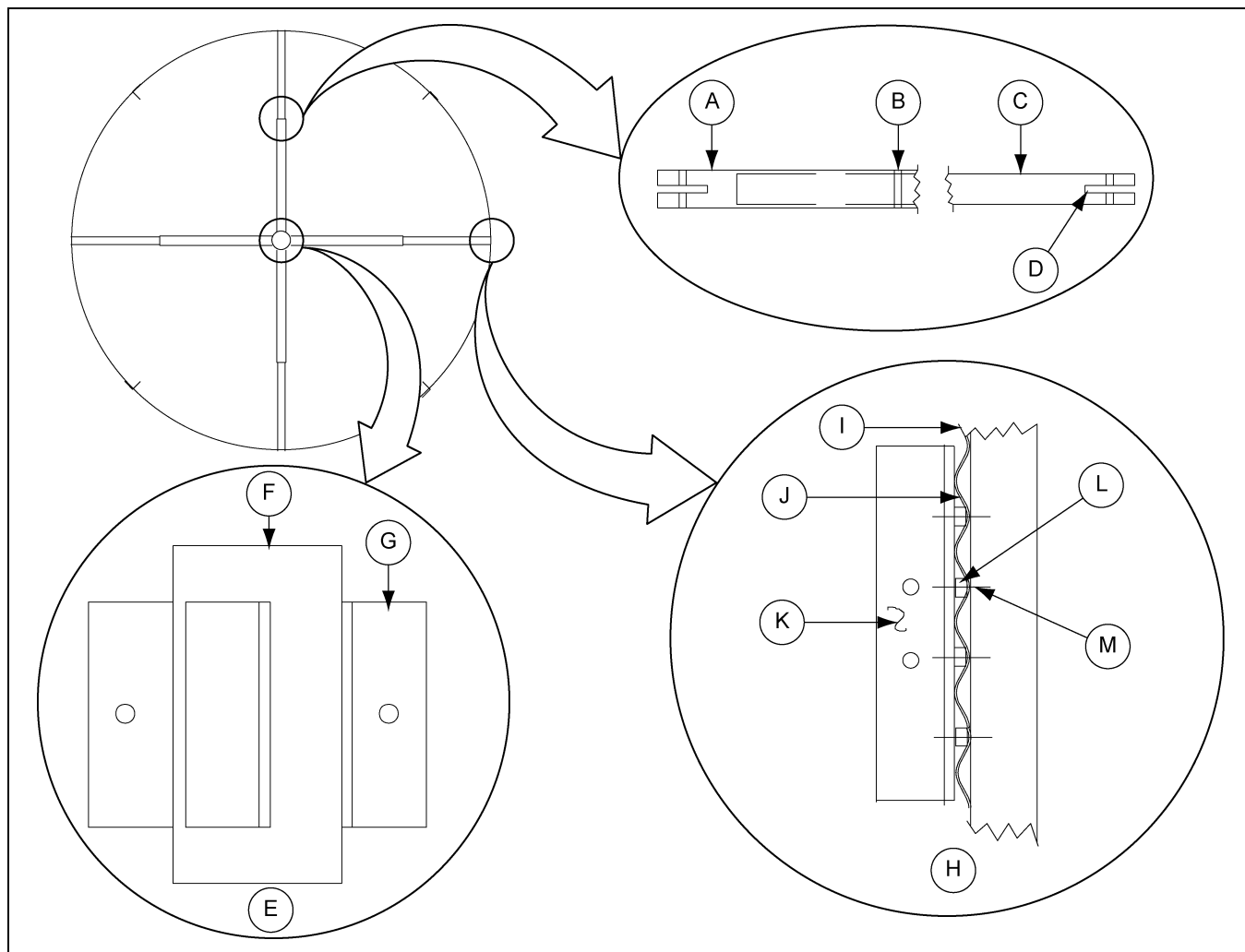

Figure 15C

Ref #	Description
A	2-1/2" Pipe
B	Bolt Hole
C	2" Pipe
D	3-1/2" x 1-1/2" Slots (2)
E	Hub Assembly
F	6" Schedule 40 Pipe
G	3" x 3" x 3/8" Angle Iron Welded to Hub (Four (4) Places)
H	Sidewall Support Angle
I	Sidewall Sheet
J	Sidewall Stiffener
K	Lifting Bracket 3" x 3" x 3/8" Angle
L	Extra Nut or Sidewall Spacer
M	3/8" Grade 8 Bolts

15. Hoisting

Hoist Instructions (Continued)

3. To simplify the setting process, bend the sealing lip inward slightly to allow sidewall sheet clearance. Bolt the sealing strip to the bottom of the sheet and apply final sealing. Typical sealing material such as non-reactive silicon caulk should be applied. Shim between the bottom of the stiffeners and the compression angle ring for level alignment if necessary.
4. **After tank is secured, remove the spider or horizontal bracing and all hoisting attachments and cables.**

After lifting the tank, clean all dirt and debris from the base of the tank.

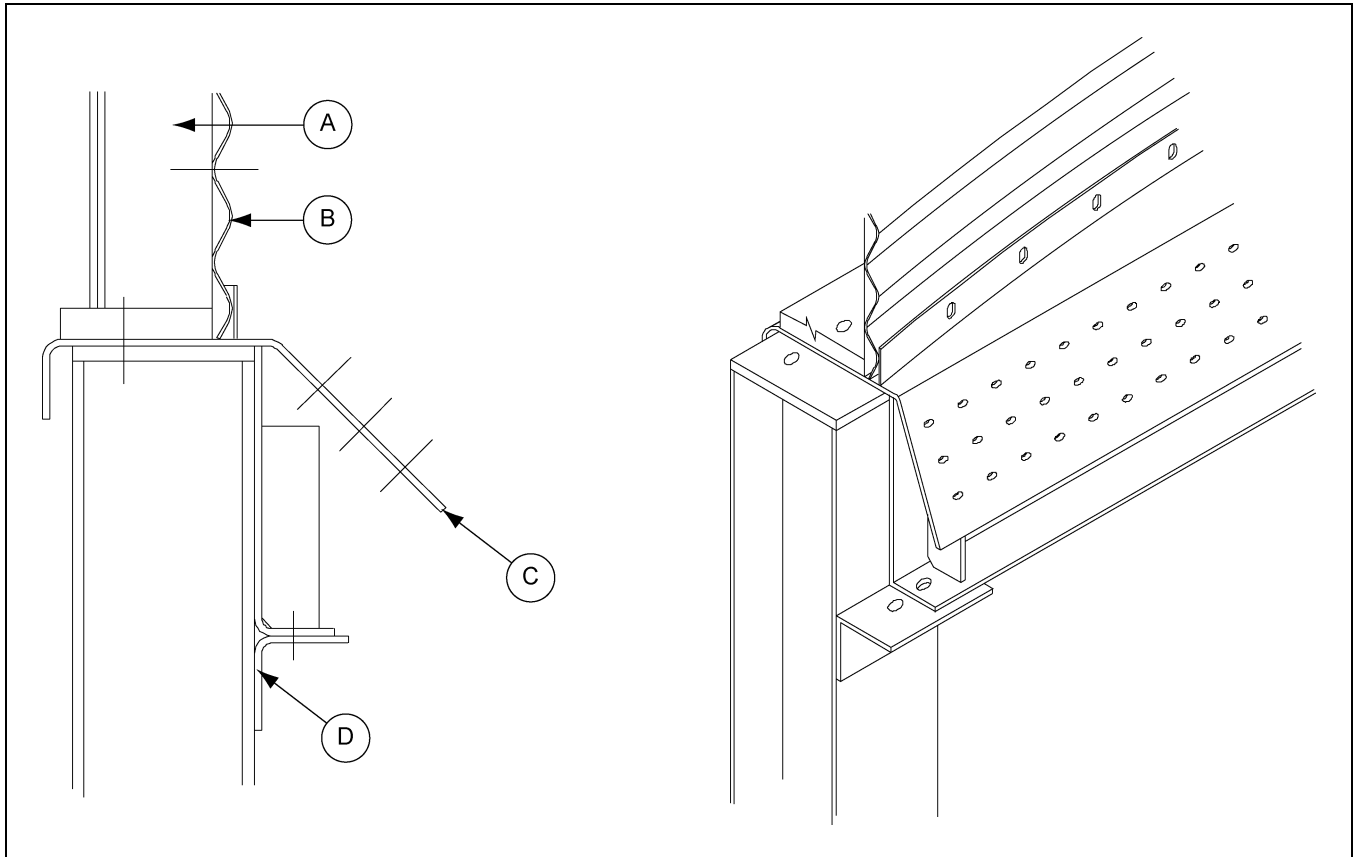

Figure 15D Tank on Support Columns

Ref #	Description
A	Sidewall Base Stiffener
B	Sidewall
C	Compression Angle Ring
D	Support Column Weldment

GSI Group, LLC Limited Warranty

The GSI Group, LLC ("GSI") warrants products which it manufactures to be free of defects in materials and workmanship under normal usage and conditions for a period of 12 months after sale to the original end-user or if a foreign sale, 14 months from arrival at port of discharge, whichever is earlier. The end-user's sole remedy (and GSI's only obligation) is to repair or replace, at GSI's option and expense, products that in GSI's judgment, contain a material defect in materials or workmanship. Expenses incurred by or on behalf of the end-user without prior written authorization from the GSI Warranty Group shall be the sole responsibility of the end-user.

Warranty Extensions:

The Limited Warranty period is extended for the following products:

	Product	Warranty Period	
AP Fans and Flooring	Performer Series Direct Drive Fan Motor	3 Years	* Warranty prorated from list price: 0 to 3 years - no cost to end-user 3 to 5 years - end-user pays 25% 5 to 7 years - end-user pays 50% 7 to 10 years - end-user pays 75%
	All Fiberglass Housings	Lifetime	
	All Fiberglass Propellers	Lifetime	
Cumberland Feeding/Watering Systems	Feeder System Pan Assemblies	5 Years **	** Warranty prorated from list price: 0 to 3 years - no cost to end-user 3 to 5 years - end-user pays 50%
	Feed Tubes (1-3/4" and 2.00")	10 Years *	
	Centerless Augers	10 Years *	
	Watering Nipples	10 Years *	
Grain Systems	Grain Bin Structural Design	5 Years	
Grain Systems Farm Fans Zimmerman	Portable and Tower Dryers	2 Years	† Motors, burner components and moving parts not included. Portable dryer screens included. Tower dryer screens not included.
	Portable and Tower Dryer Frames and Internal Infrastructure †	5 Years	

GSI further warrants that the portable and tower dryer frame and basket, excluding all auger and auger drive components, shall be free from defects in materials for a period of time beginning on the twelfth (12th) month from the date of purchase and continuing until the sixtieth (60th) month from the date of purchase (extended warranty period). During the extended warranty period, GSI will replace the frame or basket components that prove to be defective under normal conditions of use without charge, excluding the labor, transportation, and/or shipping costs incurred in the performance of this extended warranty.

Conditions and Limitations:

THERE ARE NO WARRANTIES THAT EXTEND BEYOND THE LIMITED WARRANTY DESCRIPTION SET FORTH ABOVE. SPECIFICALLY, GSI MAKES NO FURTHER WARRANTY OF ANY KIND, EXPRESS OR IMPLIED, INCLUDING, WITHOUT LIMITATION, WARRANTIES OF MERCHANTABILITY OR FITNESS FOR A PARTICULAR PURPOSE OR USE IN CONNECTION WITH: (I) PRODUCT MANUFACTURED OR SOLD BY GSI OR (II) ANY ADVICE, INSTRUCTION, RECOMMENDATION OR SUGGESTION PROVIDED BY AN AGENT, REPRESENTATIVE OR EMPLOYEE OF GSI REGARDING OR RELATED TO THE CONFIGURATION, INSTALLATION, LAYOUT, SUITABILITY FOR A PARTICULAR PURPOSE, OR DESIGN OF SUCH PRODUCTS.

GSI shall not be liable for any direct, indirect, incidental or consequential damages, including, without limitation, loss of anticipated profits or benefits. The sole and exclusive remedy is set forth in the Limited Warranty, which shall not exceed the amount paid for the product purchased. This warranty is not transferable and applies only to the original end-user. GSI shall have no obligation or responsibility for any representations or warranties made by or on behalf of any dealer, agent or distributor.

GSI assumes no responsibility for claims resulting from construction defects or unauthorized modifications to products which it manufactured. Modifications to products not specifically delineated in the manual accompanying the equipment at initial sale will void the Limited Warranty.

This Limited Warranty shall not extend to products or parts which have been damaged by negligent use, misuse, alteration, accident or which have been improperly/inadequately maintained. This Limited Warranty extends solely to products manufactured by GSI.

Prior to installation, the end-user has the responsibility to comply with federal, state and local codes which apply to the location and installation of products manufactured or sold by GSI.

This equipment shall be installed in accordance with the current installation codes and applicable regulations, which should be carefully followed in all cases. Authorities having jurisdiction should be consulted before installations are made.

G S I G R O U P



GSI Group
1004 E. Illinois St.
Assumption, IL 62510-0020
Phone: 1-217-226-4421
Fax: 1-217-226-4420
www.gsiag.com



GSI is a worldwide brand of AGCO Corporation.