



## Additional Tools and Materials Needed:

- Clamp
- Assorted Wrench Set
- Ratchet and Socket Set
- Ground Control Chain (If you do not already have one)

## Instructions

1. Disassemble existing lid. Start by detaching the current cotter pins located in the ground control chain on latch side of the bin lid. Retain the end of the chain for easy access when re-attaching the chain to the new bin lid lever arm. (See Figure 2 on Page 2.) Ensure there is a functional roof eave bracket in place to use with the new lid.

Carefully loosen and remove the back bracing bolts of the old lid. Be sure to have firm grasp on the nuts on the inside of the bin to prevent them from falling down into the bin. **Be aware that the lid is spring loaded and can close rapidly.** Next with the lid closed, loosen existing bolt on the front mounting bracket of the old lid. Dispose of the old lid.

**NOTE:** If there was no previous chain, roof eave bracket or chain holder bracket, a chain will need to be purchased and the brackets included will need to be attached to the side of the bin, vertically aligned with the lever arm. (See Figure 1.)

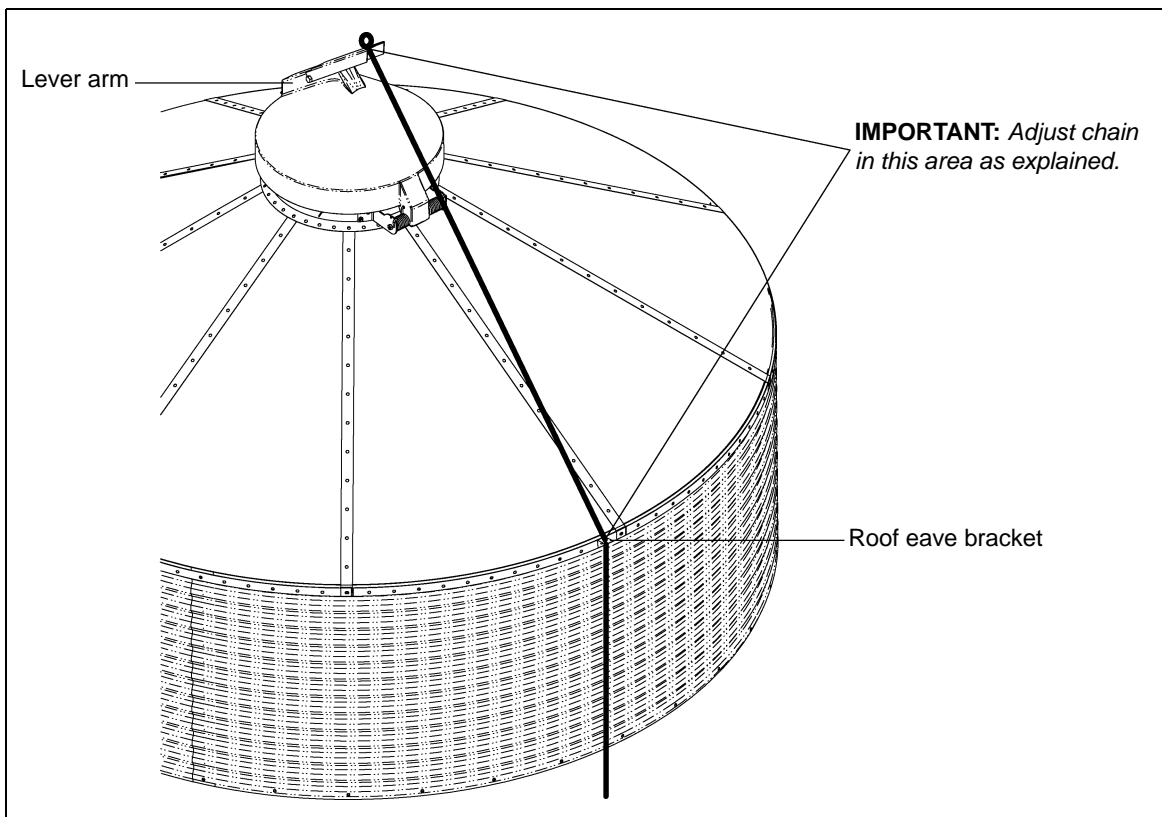
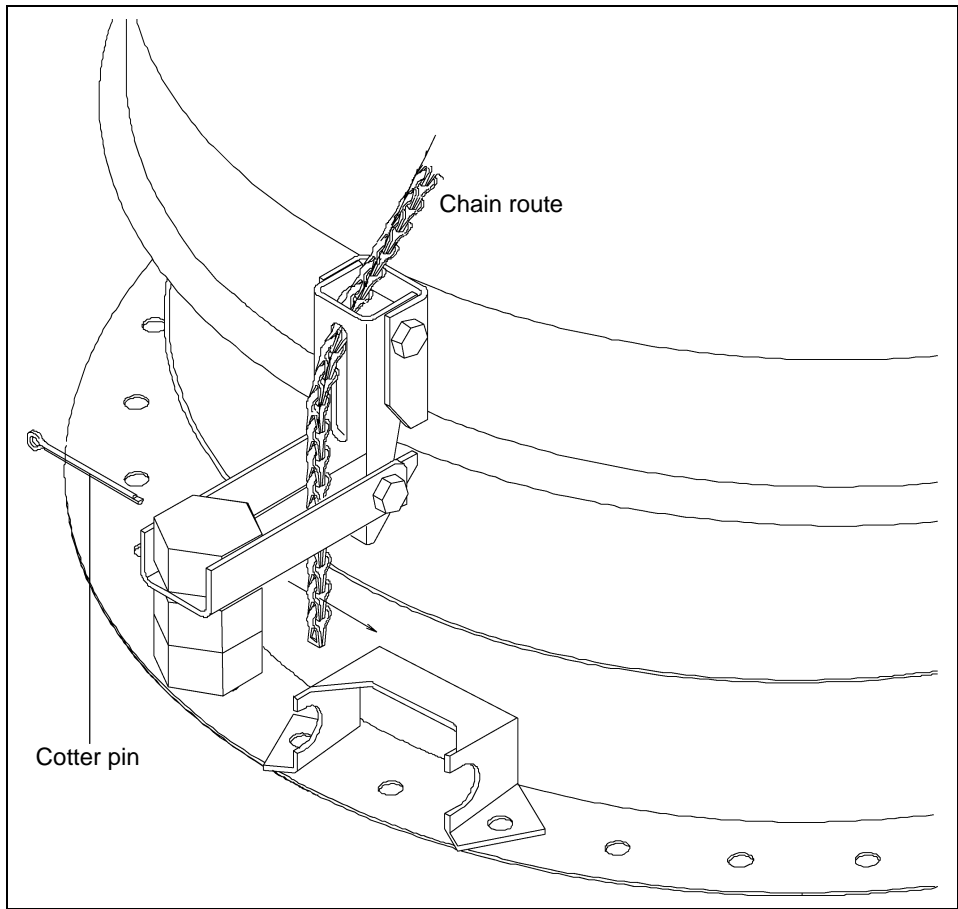


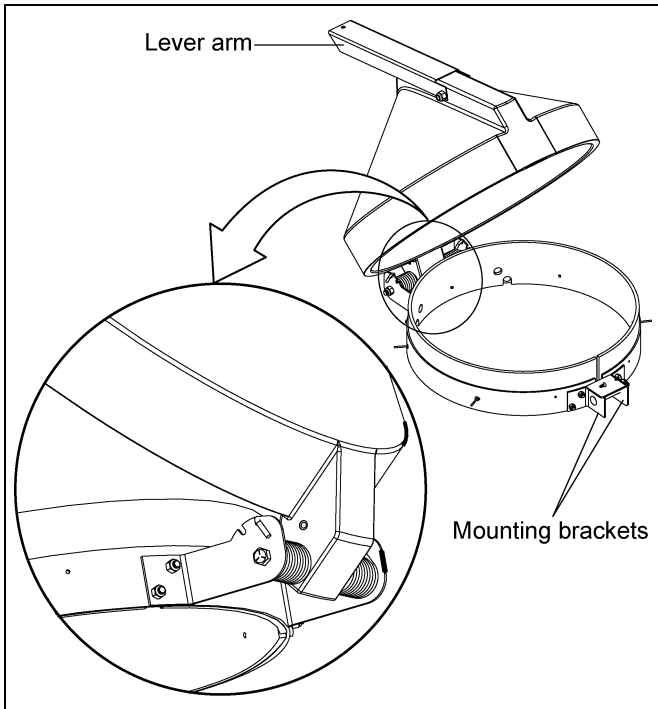
Figure 1



# BFT Bin Lid Assembly



**Figure 2** Old Style Flat Lid



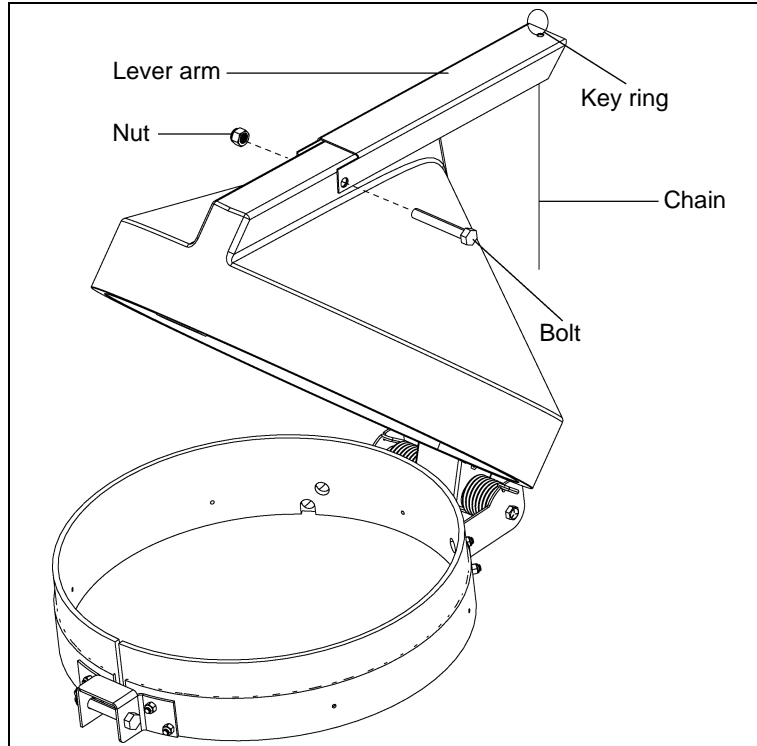
**Figure 3** New Style Cone Lid



**Figure 4**

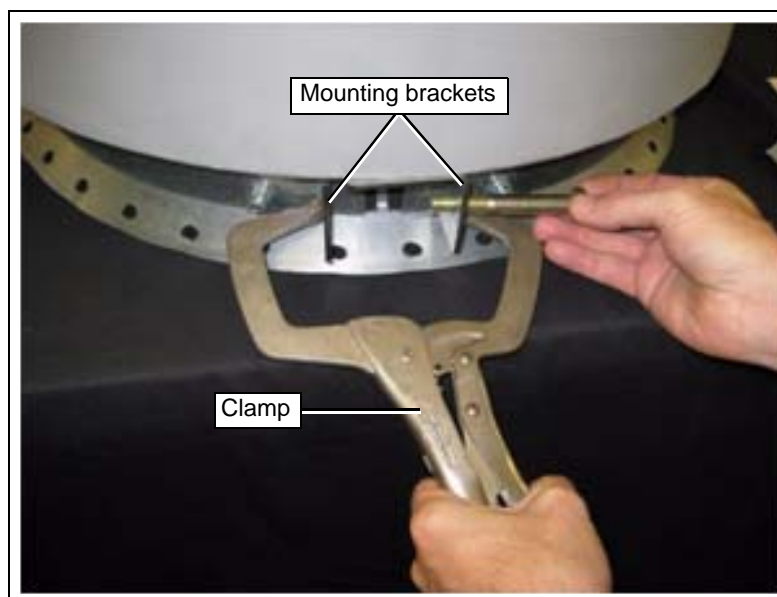
**NOTE:** The larger lid assembly uses the forward slot and the regular lid assembly uses the rear slot.

2. **With the lid closed**, align the hole in the lever arm with the hole in the bin lid. Insert 1/2" bolt through the hole and fasten with the nylock nut using 3/4" wrench and ratchet. **NOTE: DO NOT over tighten.** This is a pivot bolt and the lever arm must be able to pivot freely.



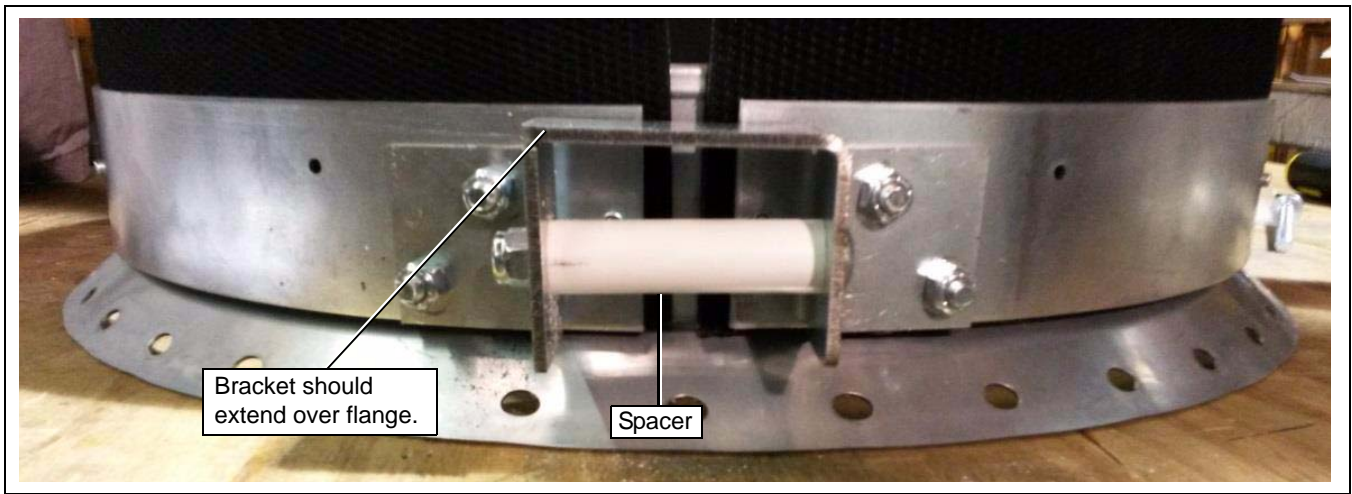
**Figure 5** Install Lever Arm and Chain

3. Place the new lid assembly over the existing peak ring collar and rotate lid assembly such that the lever arm and spring hinge line up with the roof eave bracket. (See Figure 1 on Page 1.) Use a clamp to pull the mounting brackets together. Slide the carriage bolt through the mounting bracket and then the 2-3/4" spacer and then loosely fasten the nut. (See Figure 6.) Remove clamp and then tighten the bolt with 9/16" ratchet and tighten until flush. (See Figure 7 on Page 4.)



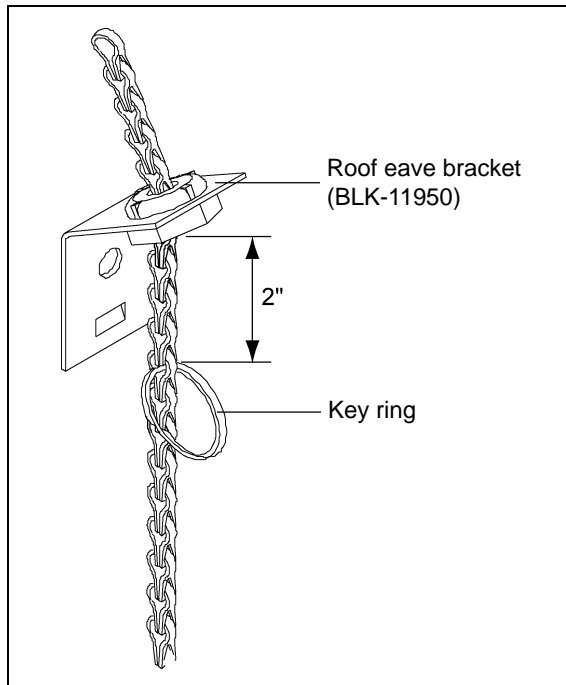
**Figure 6** Mount Lid to Peak Ring

# BFT Bin Lid Assembly

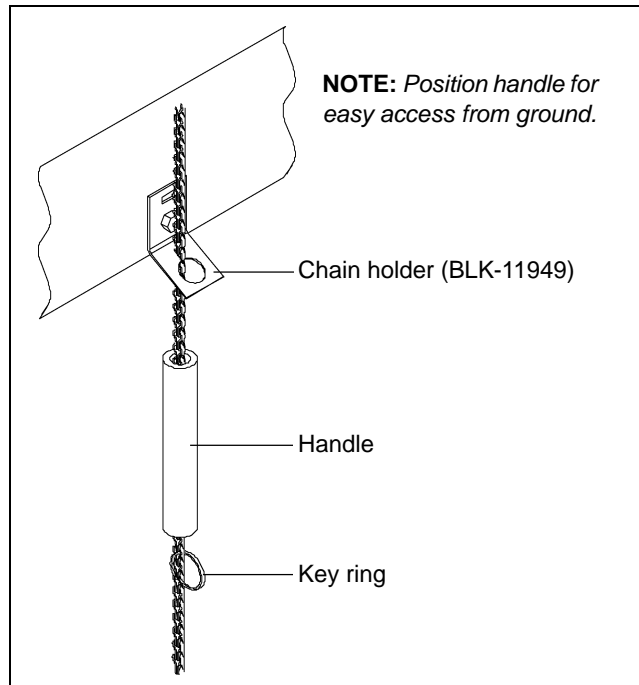


**Figure 7** Tighten Bolts Until Flush with Bracket

4. Thread the existing chain through the hole on the end of the lever arm and fasten it to the provided key ring. (See Figure 5 on Page 3.) Ensure that the ground control chain is freely looped through the roof eave bracket and chain holder. After removing the slack in the chain while the lid is fully closed and in latched position, re-position the key ring 2" below the roof eave bracket. (See Figure 8.) Re-adjust the existing handle and key ring so the handle is positioned for easy access from ground. (See Figure 9.) Check to make sure that the key rings allow the cap to fully close, but will not allow the chain enough slack on top of the cap to become wrapped around the lever arm in a high wind condition.



**Figure 8**



**Figure 9**

5. Install the decal DC-2123 to the inside of peak ring on the hinge side of the lid as shown in Figure 4 on Page 2. Decal should be clearly visible when lid is open.

**Parts List for BFT Lid Without Peak Ring for Retro (BLK-13102)**

Part #	Description	Qty
BLK-13062	BFT, Lid Assembly	1
BLK-13027	Spring, Left Hand Side Rear	1
BLK-13028	Spring, Right Hand Side Rear	1
BLK-13038	Support, Spring BFT	2
BLK-13048	Leverage Arm - BFT Lid	1
BLK-13053	Bumper, Reinforced Rubber Belting	1
BLK-13058	Retainer, Magnet, BFT Lid	1
BLK-13059	BFT, Lid Clamp Band	1
BLK-13061	BFT, Lid Clamp Band Bracket	1
BLK-13064	BFT, Lid Pivot Tube	1
BLK-13065	BFT, Lid Clamp Band Bracket	1
BLK-13066	BFT, Lid Clamp Band Bracket	1
BLK-13067	BFT, Lid Clamp Band Bracket	1
BLK-13068	BFT, Lid Magnet	1
BLK-13070	BFT, Lid	1
S-10121	Bolt, HHCS 7/16"-14 x 9" ZN Grade 5	1
S-10138	Bolt, FHSCS #10-32 x 3/8" ZN	2
BLK-13480	Spacer, 2-3/4" PVC	1
S-7236	Rivet, POE 3/16" Diameter x 0.565" Long ARSM	7
S-7382	Nylock Nut 5/16"-18 ZN Grade 5	8
S-7383	Nylock Nut 3/8"-16 ZN Grade 5	1
S-7645	Carriage Bolt 5/16"-18 x 3/4" ZN Grade 5	8
S-8234	Nylock Nut 7/16"-14 ZN Grade 2	1
S-8260	Nylock Nut 1/2"-13 ZN Grade 5	1
S-8314	Bolt, HHCS 1/2"-13 x 3-1/2" YDP Grade 8	1
S-10334	Carriage Bolt 3/8"-16 x 4" ZN Grade 5	1
BLK-13104	BFT, Ground Control Hardware Package	1
BLK-11796	4" Plastic Handle	1
BLK-11949	BFT, Chain Holder Bracket	1
BLK-11950	BFT, Roof Eave Bracket w/ Grommet	1
S-4318	Ring, 0.072" x 1.1" Key Style	3
BX-611	Box, 25 x 25 x 19 275 B/C RSC	1
DC-2123	Decal, Suffocation/Flighting, English, Grain Bin	2