



Instructions Stiffener Mounting Bracket Installation for CHT Eave Platform

1. Align the first mounting plate (3) with the top of the stiffener and field drill six holes on the stiffener flanges for 3/8" flange bolts (1).
2. Position the second mounting plate (3) at 10.314" below the top of the stiffener and field drill six holes (5) on the stiffener flanges for 3/8" flange bolts (1).

NOTE: Leave the gap at the stiffener splice between the plates (3).

3. Position the third mounting plate (3) at 18.313" below the top of the stiffener and field drill six holes (5) on the stiffener flanges for 3/8" flange bolts (1).
4. Install the three mounting plates (3) to the stiffeners (4) using 3/8" flange bolts (1) and 3/8" flange nuts (2).

NOTE: Install the flange bolts (1) with bolt heads on the outside of the mounting plate (3).

5. Repeat the [Steps 1-4](#) to install the mounting plates (3) on another stiffener. ([See Figure 1.](#))

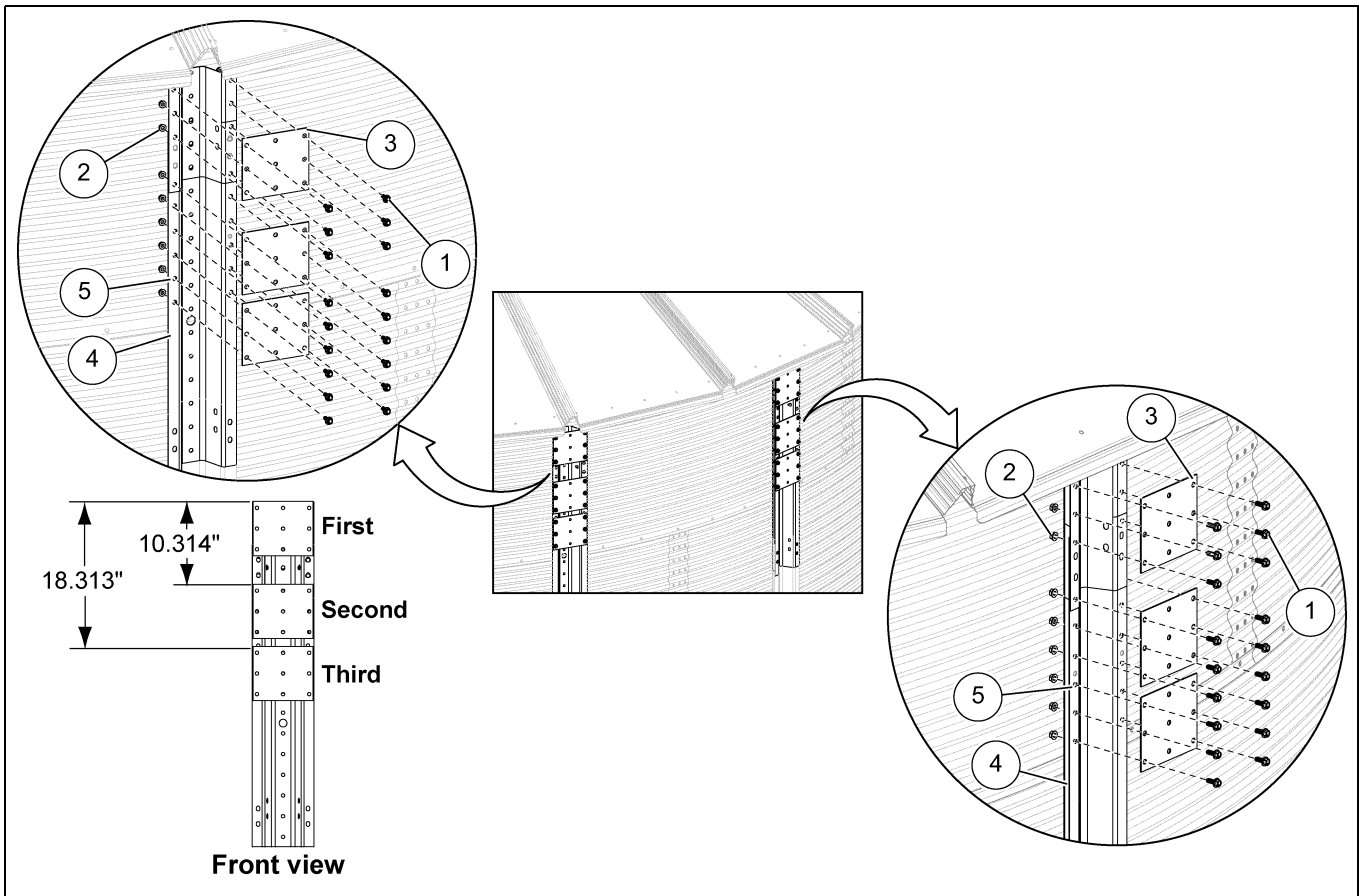

Figure 1 Mounting Plate Installation

Ref #	Part #	Description
1	S-7485	3/8"-16 x 1" Flange Bolt
2	S-9426	3/8"-16 Flange Nut
3	LDR-5572	Mounting Plate

Ref #	Description
4	Stiffener
5	3/8" Field Drilled Holes



Stiffener Mounting Bracket Installation for CHT Eave Platform

6. Install the left mounting bracket (6) and right mounting bracket (7) to the mounting plates (3) using 3/8" flange bolts (1) and 3/8" flange nuts (2). *(See Figure 2.)*

NOTE: Install the flange bolts (1) with bolt heads on the inside of the plate (3).

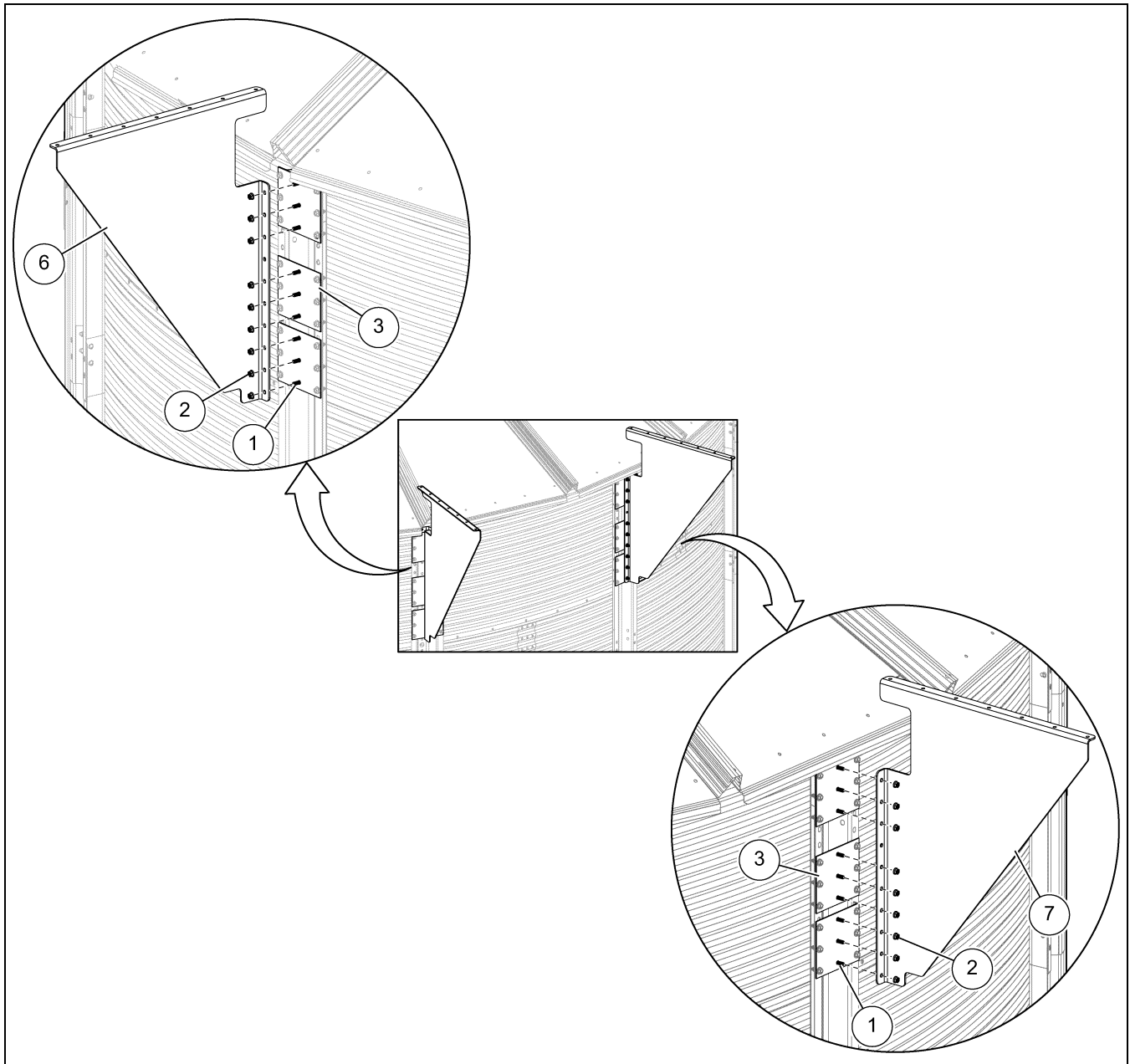

Figure 2 Mounting Brackets Installation

Ref #	Part #	Description
1	S-7485	3/8"-16 x 1" Flange Bolt
2	S-9426	3/8"-16 Flange Nut
3	LDR-5572	Mounting Plate
6	LDR-5567	Left Mounting Bracket
7	LDR-5568	Right Mounting Bracket

Stiffener Mounting Bracket Installation for CHT Eave Platform

7. Position the first hole of the middle mounting bracket (10) on the second hill of the sidewall (9) and pre-drill 1/4" holes (8). *(See Figure 3.)*
8. Install the middle mounting bracket (10) to the sidewall (9) using 5/16" x 1-1/2" screws (11).

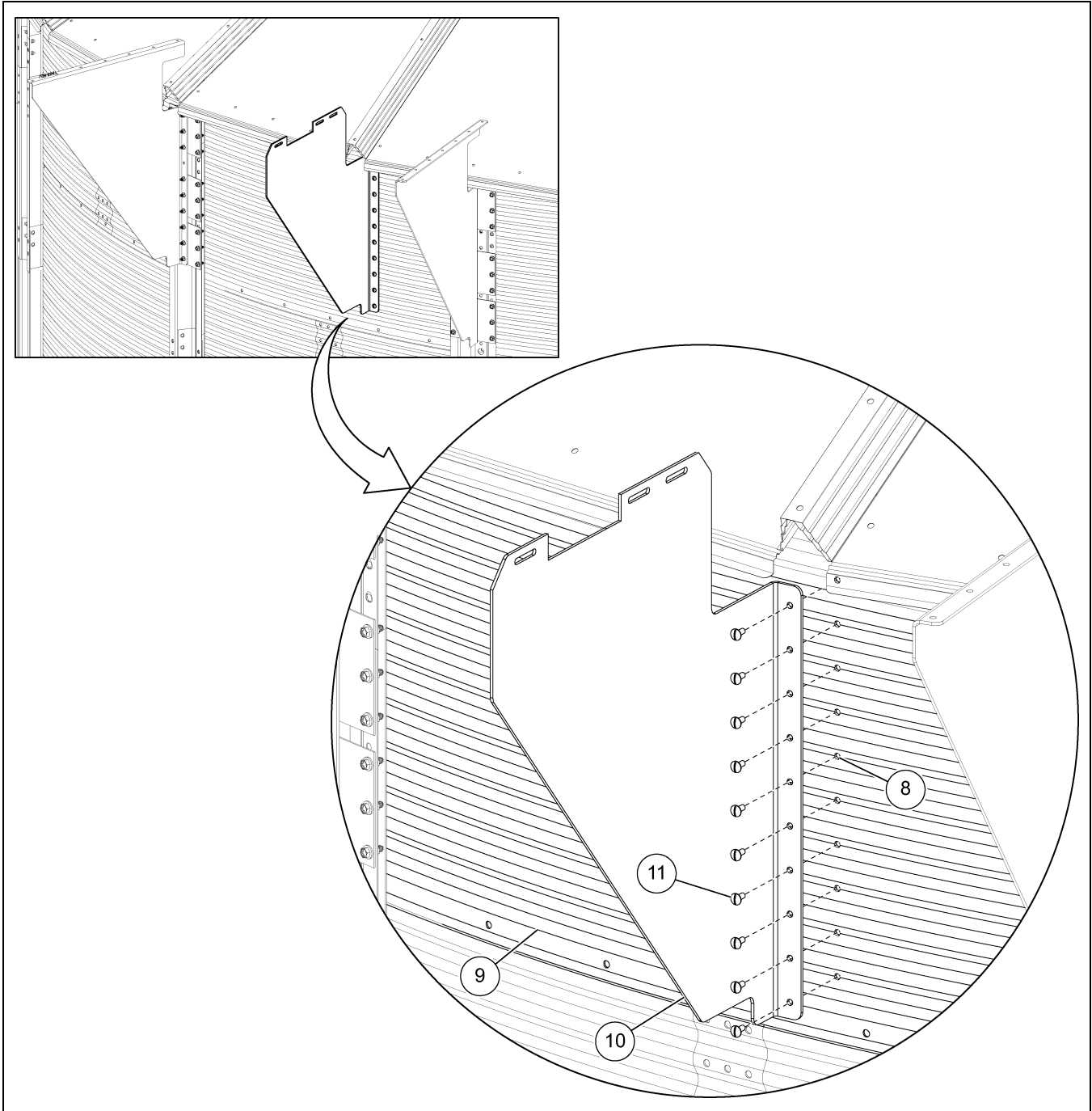

Figure 3 Middle Bracket Installation

Ref #	Description
8	1/4" Pre-Drilled Hole
9	Sidewall

Ref #	Part #	Description
10	LDR-5571	Middle Mounting Bracket
11	S-9061	5/16" x 1-1/2" Screw