

JS500 4" Commercial Hopper Tank

18', 21' and 24' Diameter Tanks

Owner's Manual

PNEG-603-JS

Date: 09-22-14

GSI GROUP



PNEG-603-JS

All information, illustrations, photos, and specifications in this manual are based on the latest information available at the time of publication. The right is reserved to make changes at any time without notice.

Contents

Chapter 1 Introduction	5
Chapter 2 Safety	6
Safety Guidelines	6
Safety Instructions	7
Safety Sign-Off Sheet	9
General Safety Statement	10
Proper Storage of Grain Bin/Silo Materials Prior to Construction	11
Chapter 3 Decals	12
Chapter 4 FCHT Base Plate Layouts	16
18' Diameter FCHT Base Plate Layout	16
18' Diameter FCHT Foundation	17
21' Diameter FCHT Base Plate Layout	18
21' Diameter FCHT Foundation	19
24' Diameter FCHT Base Plate Layout	20
24' Diameter FCHT Foundation	21
Chapter 5 FCHT Substructure	22
FCHT Parts List for Substructure	22
Typical FCHT Column	23
Chapter 6 Hopper Assembly	24
Hopper Section Assembly 18'-24' (5.49 m-7.32 m) Diameter Hopper Tank	24
Hopper Support System Layout	25
Hopper Bottom	26
Rack and Pinion	27
Chapter 7 Hardware	28
Identifying Bolt Grades	28
Bolting Requirements	29
Bolting Requirements 2 Stiffeners per Sidewall Sheet	30
Bolt Usage	31
Color Chart for Bin Hardware Bucket Lids	33
Chapter 8 FCHT Gauge Charts	34
FCHT Series - 4.00" Corrugation 18' Diameter Sidewall and Stiffener Gauge Chart	34
FCHT Series - 4.00" Corrugation 21' Diameter Sidewall and Stiffener Gauge Chart	35
FCHT Series - 4.00" Corrugation 24' Diameter Sidewall and Stiffener Gauge Chart	35
Chapter 9 Sidewall Assembly	36
Sidewall Erection Instructions	36
Chapter 10 Lifting Jack	39
Lifting Jack Usage	39
Chapter 11 Stiffeners	40
Top Stiffener Starting Location	40
FCHT Stiffeners	41
Stiffener Splicing Details	43
Stiffener Splicing	43

Table of Contents

Chapter 12 Round Access Door	44
Access Door Weldment Assembly Hardware Package (PLS-41985)	44
Chapter 13 Aeration	45
Aeration Package (Optional)	45
Chapter 14 Flashing Instructions (Optional)	48
Chapter 15 Ladders	50
Hopper Ladder Supports	50
Chapter 16 Hoisting	51
Hoisting Recommendations	51
Chapter 17 Support Columns	54
Tank on Support Columns	54
Chapter 18 Warranty	55

READ THIS MANUAL carefully to learn how to properly use and install equipment. Failure to do so could result in personal injury or equipment damage.

INSPECT the shipment immediately upon arrival. The customer is responsible for ensuring that all quantities are correct. The customer should report and note any damage or shortage on the bill of lading to justify their claim to the transport company.

THIS MANUAL SHOULD BE CONSIDERED a permanent part of your equipment and should be easily accessible when needed.

This warranty provides you the assurance that the company will back its products when defects appear within the warranty period. In some circumstances, the company also provides field improvements, often without charge to the customer, even if the product is out of warranty. Should the equipment be abused, or modified to change its performance beyond the factory specifications, the warranty will become void and field improvements may be denied.

Safety Guidelines

This manual contains information that is important for you, the owner/operator, to know and understand. This information relates to protecting **personal safety** and **preventing equipment problems**. It is the responsibility of the owner/operator to inform anyone operating or working in the area of this equipment of these safety guidelines. To help you recognize this information, we use the symbols that are defined below. Please read the manual and pay attention to these sections. Failure to read this manual and its safety instructions is a misuse of the equipment and may lead to serious injury or death.



This is the safety alert symbol. It is used to alert you to potential personal injury hazards. Obey all safety messages that follow this symbol to avoid possible injury or death.



This symbol indicates an imminently hazardous situation which, if not avoided, **will result in serious injury or death**.



This symbol indicates a potentially hazardous situation which, if not avoided, **may result in serious injury or death**.



This symbol indicates a potentially hazardous situation which, if not avoided, **may result in minor or moderate injury**.



This symbol indicates a potentially hazardous situation which, if not avoided, **may result in property damage**.

Safety Instructions

Our foremost concern is your safety and the safety of others associated with this equipment. We want to keep you as a customer. This manual is to help you understand safe operating procedures and some problems that may be encountered by the operator and other personnel.

As owner and/or operator, it is your responsibility to know what requirements, hazards, and precautions exist, and to inform all personnel associated with the equipment or in the area. Safety precautions may be required from the personnel. Avoid any alterations to the equipment. Such alterations may produce a very dangerous situation where **SERIOUS INJURY** or **DEATH** may occur.

This equipment shall be installed in accordance with the current installation codes and applicable regulations, which should be carefully followed in all cases. Authorities having jurisdiction should be consulted before installations are made.

Follow Safety Instructions

Carefully read all safety messages in this manual and safety signs on your machine. Keep signs in good condition. Replace missing or damaged safety signs. Be sure new equipment components and repair parts include the current safety signs. Replacement safety signs are available from the manufacturer.

Learn how to operate the machine and how to use controls properly. Do not let anyone operate without instruction.

Keep your machinery in proper working condition. Unauthorized modifications to the machine may impair the function and/or safety and affect machine life.

If you do not understand any part of this manual or need assistance, contact your dealer.

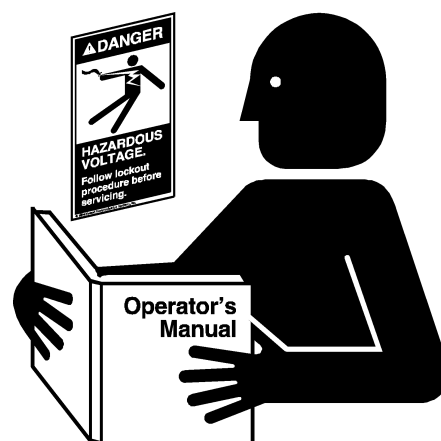

Read and Understand Manual

Practice Safe Maintenance

Understand service procedures before doing work. Keep area clean and dry.

Never lubricate, service, or adjust machine while it is in operation. Keep hands, feet, and clothing away from rotating parts.

Keep all parts in good condition and properly installed. Fix damage immediately. Replace worn or broken parts. Remove any built-up grease, oil, and debris.



Maintain Equipment and Work Area

2. Safety

Prepare for Emergencies

Be prepared if fire starts.

Keep a first aid kit and fire extinguisher handy.

Keep emergency numbers for doctors, ambulance service, hospital, and fire department near your telephone.

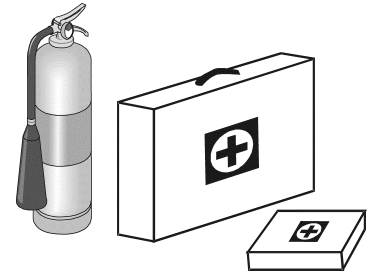

Keep Emergency Equipment Quickly Accessible

Wear Protective Clothing

Wear close-fitting clothing and safety equipment appropriate to the job.

Remove all jewelry.

Tie long hair up and back.

Wear safety glasses at all times to protect eyes from debris.

Wear gloves to protect your hands from sharp edges on plastic or steel parts.

Wear steel-toed boots to help protect your feet from falling debris. Tuck in any loose or dangling shoestrings.

A respirator may be needed to prevent breathing potentially toxic fumes and dust.

Wear a hard hat to help protect your head.

Wear appropriate fall protection equipment when working at elevations greater than six feet (6').

Eye Protection

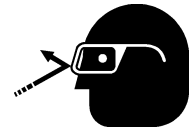

Gloves



Steel-Toed Boots



Respirator



Hard Hat



Fall Protection



2. Safety

General Safety Statement

Our foremost concern is your safety and the safety of others associated with grain handling equipment. This manual is to help you understand safe operating procedures and some problems that may be encountered by the operator and other personnel.

As owner and/or operator, you are responsible to know what requirements, hazards, and precautions exist and inform all personnel associated with the equipment or in the area. Safety precautions may be required from the personnel. Avoid any alterations to the equipment, which may produce a very dangerous situation, where **SERIOUS INJURY** or **DEATH** may occur.

You should consider the location of the bin site relative to power line locations or electrical transmission equipment. Contact your local power company to review your installation plan or for information concerning required equipment clearance. Clearance of portable equipment that may be taken to the bin site should also be reviewed and considered. Any electrical control equipment in contact with the bin should be properly grounded and installed in accordance with National Electric Code provisions and other local or national codes.

This product is intended for the use of grain storage only. Any other use is a misuse of the product.



This product has sharp edges, which may cause serious injury. To avoid injury, handle sharp edges with caution and always use proper protective clothing and equipment.

Sidewall bundles or sheets must be stored in a safe manner. The safest method of storing sidewall bundles is laying horizontally with the arch of the sheet upward, like a dome. Sidewall sheets stored on edge must be secured so that they cannot fall over and cause injury. Use care when handling and moving sidewall bundles.

Personnel operating or working around equipment should read this manual. This manual must be delivered with equipment to its owner. Failure to read this manual and its safety instructions is a misuse of the equipment.

Proper Storage of Grain Bin/Silo Materials Prior to Construction

Wet storage stain (rust) will develop when closely packed bundles of galvanized material, such as sidewall and roof sheets, have moisture present. Inspect roof and sidewall bundles on arrival for any moisture. If moisture is present, it must not be allowed to remain between the sheets. Separate the sheets or panels immediately and wipe them down. Spray with a light oil or diesel fuel.

If possible, sidewall bundles, roof sheets and other closely packed galvanized materials should be stored in a dry, climate controlled building. If outdoor storage is unavoidable, the materials should be stored so that they are raised above the ground and vegetation. Any stacking and spacing materials should not be corrosive or wet. Be sure to protect materials from the weather, but permit air movement around the bundles if possible.

Storing roof bundles and sidewall sheets at a slight incline can also help minimize the presence of moisture. Storing the bundles with the center of the dome up (like an arch) is one option for minimizing moisture during storage. Sidewall bundles can also be stored on edge but must be secured so that they do not fall over and cause injury.

If “white rust” or “wet storage stain” occurs, contact the manufacturer immediately about ways to minimize the adverse effect upon the galvanized coating.

3. Decals

The manufacturer does not warrant any roof damage caused by excessive vacuum or internal pressure from fans or other air moving systems. Adequate ventilation and/or “makeup air” devices should be provided for all powered air handling systems. The manufacturer does not recommend the use of downward flow systems (suction). Severe roof damage can result from any blockage of air passages. Running fans during high humidity/cold weather conditions can cause air exhaust or intake ports to freeze.



CAUTION

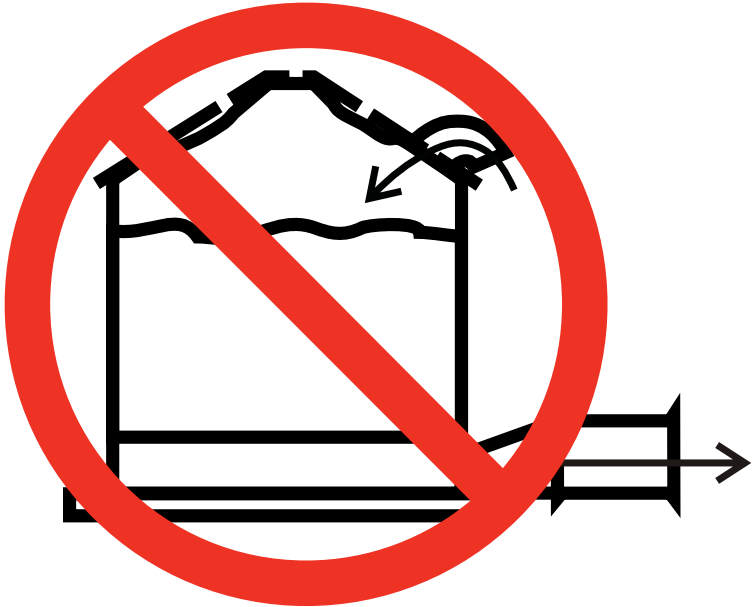

Excessive vacuum (or pressure) may damage roof. Use positive aeration system. Make sure all roof vents are open and unobstructed. Start roof fans when supply fans are started. Do not operate when conditions exist that may cause roof vent icing.

GSI Group, Inc. 217-226-4421DC-969

ATTENTION: The decal shown below should be present on the outside of the door cover of the 2 ring, 24" porthole door cover and roof manway cover. If a decal has been damaged or is missing in any of these locations, contact the manufacturer for a free replacement decal.

GSI Decals

1004 E. Illinois St.
Assumption, IL. 62510
Phone: 1-217-226-4421



DANGER

 <p>Rotating flighting will kill or dismember.</p>	 <p>Flowing material will trap and suffocate.</p>	 <p>Crusted material will collapse and suffocate.</p>
--	---	---

Keep clear of all augers. DO NOT ENTER this bin!

If you must enter the bin:

1. Shut off and lock out all power.
2. Use a safety harness and safety line.
3. Station another person outside the bin.
4. Avoid the center of the bin.
5. Wear proper breathing equipment or respirator.

Failure to heed these warnings will result in serious injury or death.

GSI GROUP, INC. 217-226-4421
DC-GBC-1A

3. Decals

ATTENTION: The decal shown below should be present on the outside of the door cover of the 2 ring, 24" porthole door cover and roof manway cover. If a decal has been damaged or is missing in any of these locations, contact the manufacturer for a free replacement decal.

GSI Decals

1004 E. Illinois St.
Assumption, IL. 62510
Phone: 1-217-226-4421



WARNING

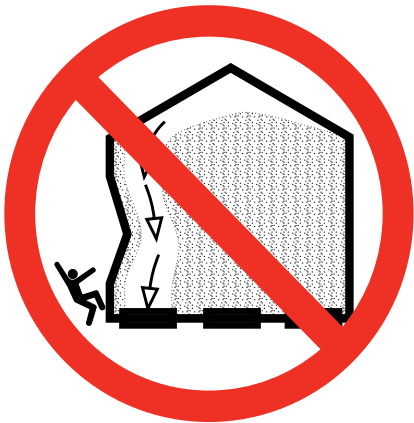

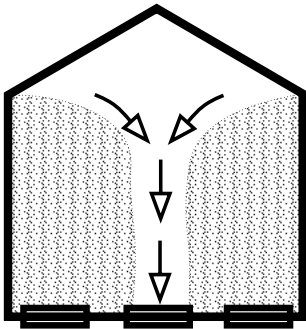

UNLOADING INSTRUCTIONS:

1. Use **CENTER FLOOR OUTLET ONLY** until **NO** grain remains above this outlet.
2. Side floor outlets to be used **ONLY** when above condition is satisfied.
3. Lock all side floor outlets to avoid accidental premature use.
4. See manufacturers instructions for proper use of factory supplied sidedraw (wall) discharge systems.

**Failure to heed these warnings
could result in serious injury, death,
structural damage or collapse of tank.**

GSI GROUP, INC. 217-226-4421DC-GBC-2A



Sidewall and stiffener gauge sheets are not included in this manual. They may be obtained by calling GSI if they are not attached to the front of this manual.

4. FCHT Base Plate Layouts

18' Diameter FCHT Base Plate Layout

NOTE: This is for standard GSI tanks only. Consult GSI engineering for special tank configurations.

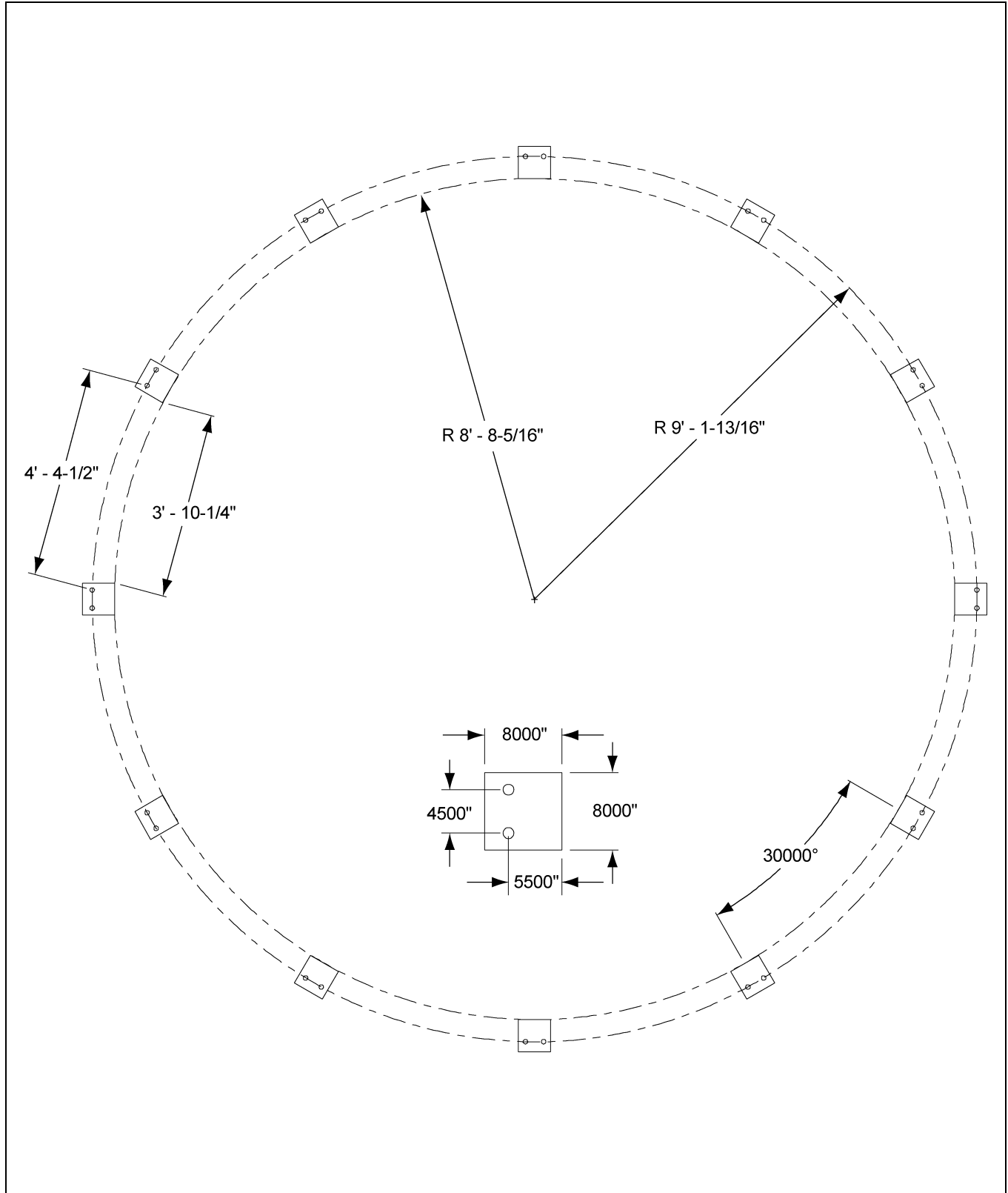

Figure 4A

18' Diameter FCHT Foundation

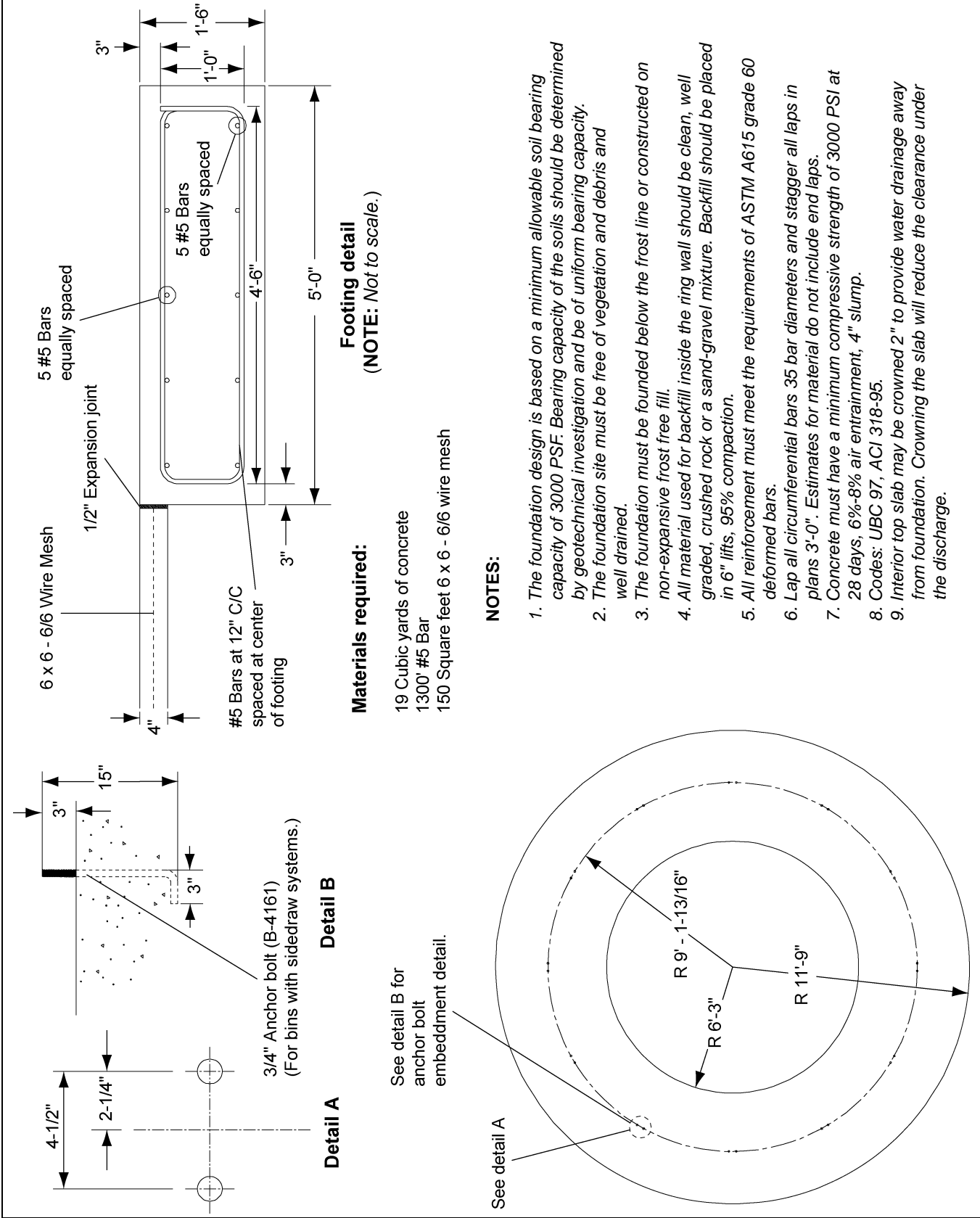

Figure 4B

4. FCHT Base Plate Layouts

21' Diameter FCHT Base Plate Layout

NOTE: This is for standard GSI tanks only. Consult GSI engineering for special tank configurations.

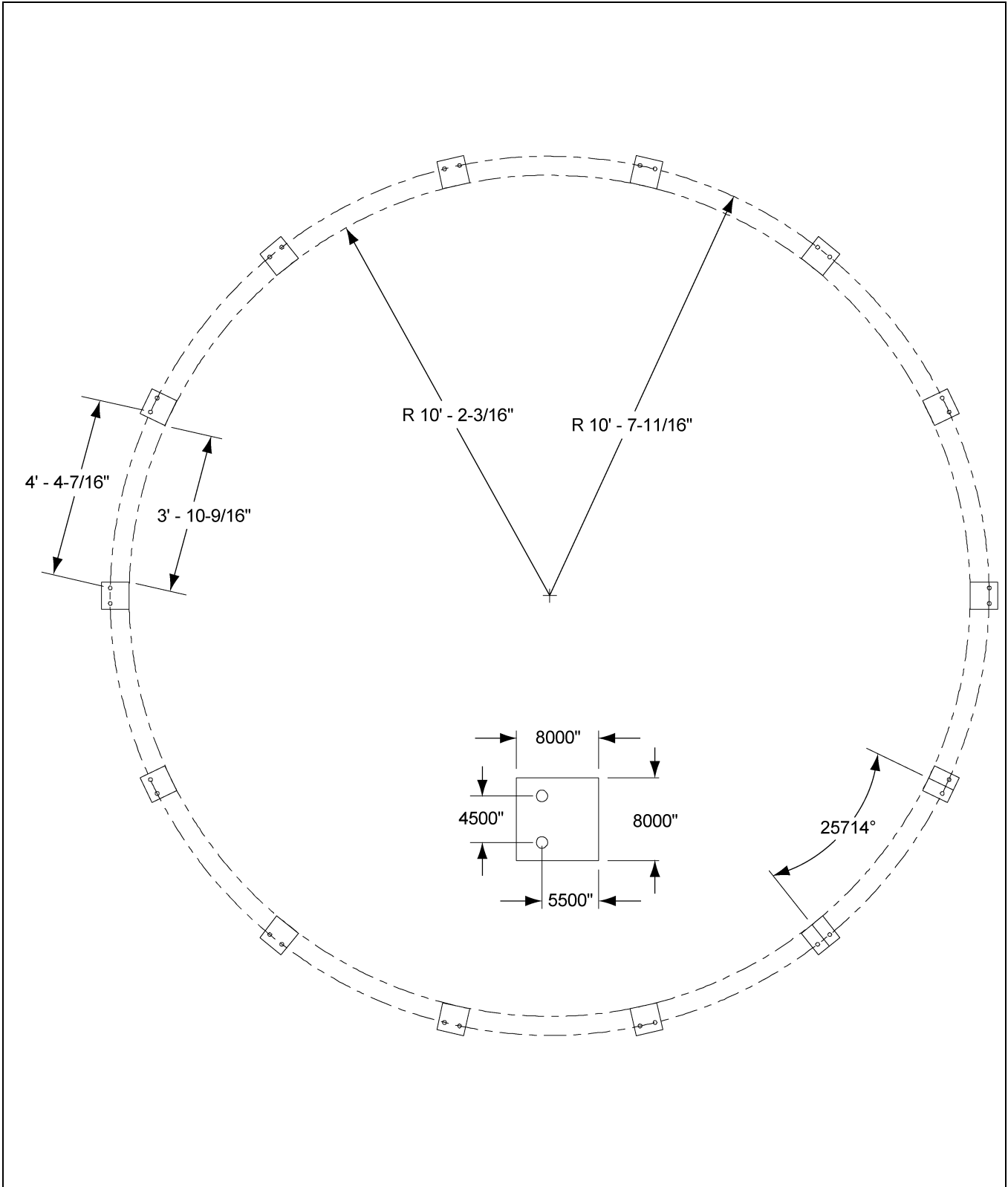

Figure 4C

21' Diameter FCHT Foundation

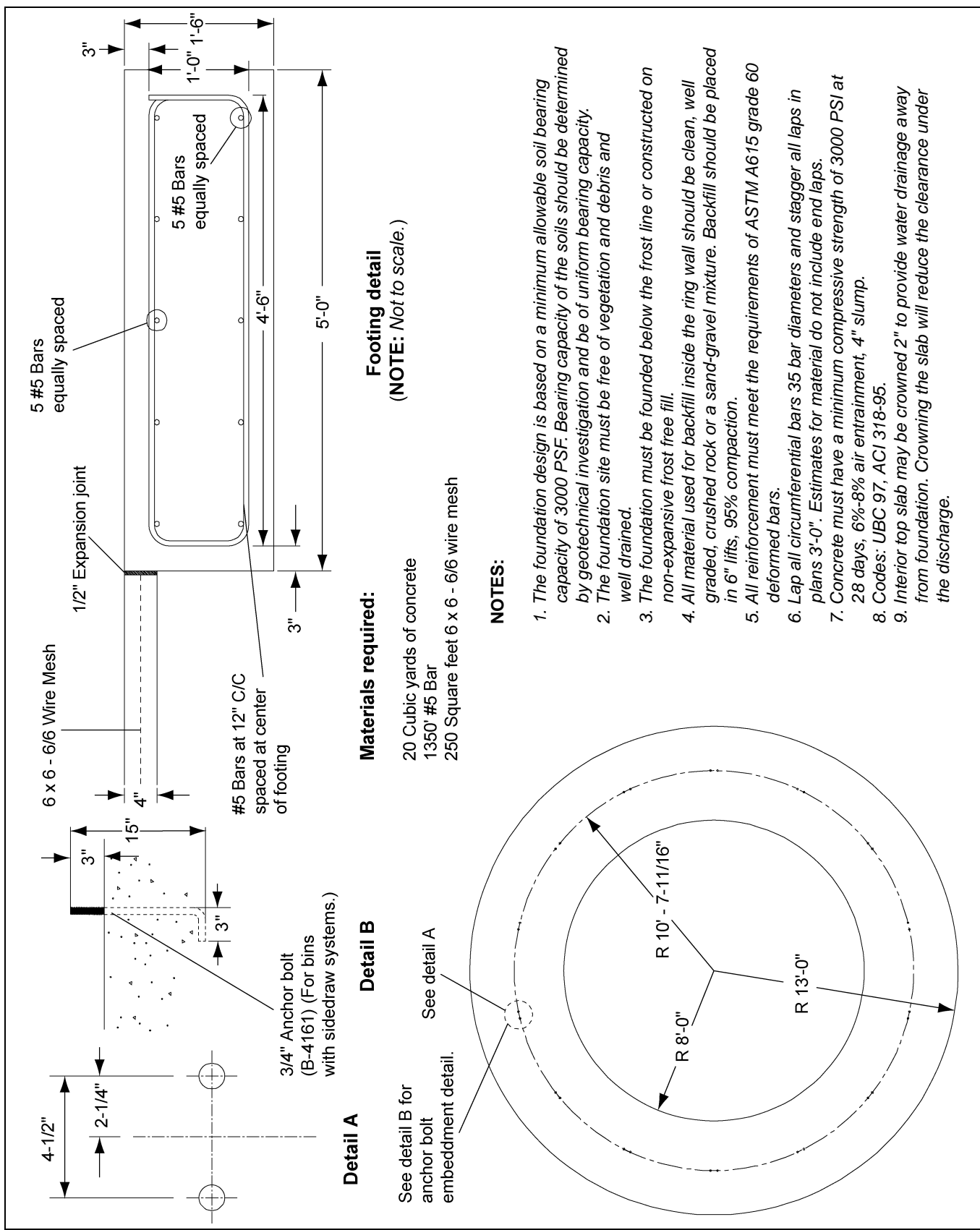

Figure 4D

4. FCHT Base Plate Layouts

24' Diameter FCHT Base Plate Layout

NOTE: This is for standard GSI tanks only. Consult GSI engineering for special tank configurations.

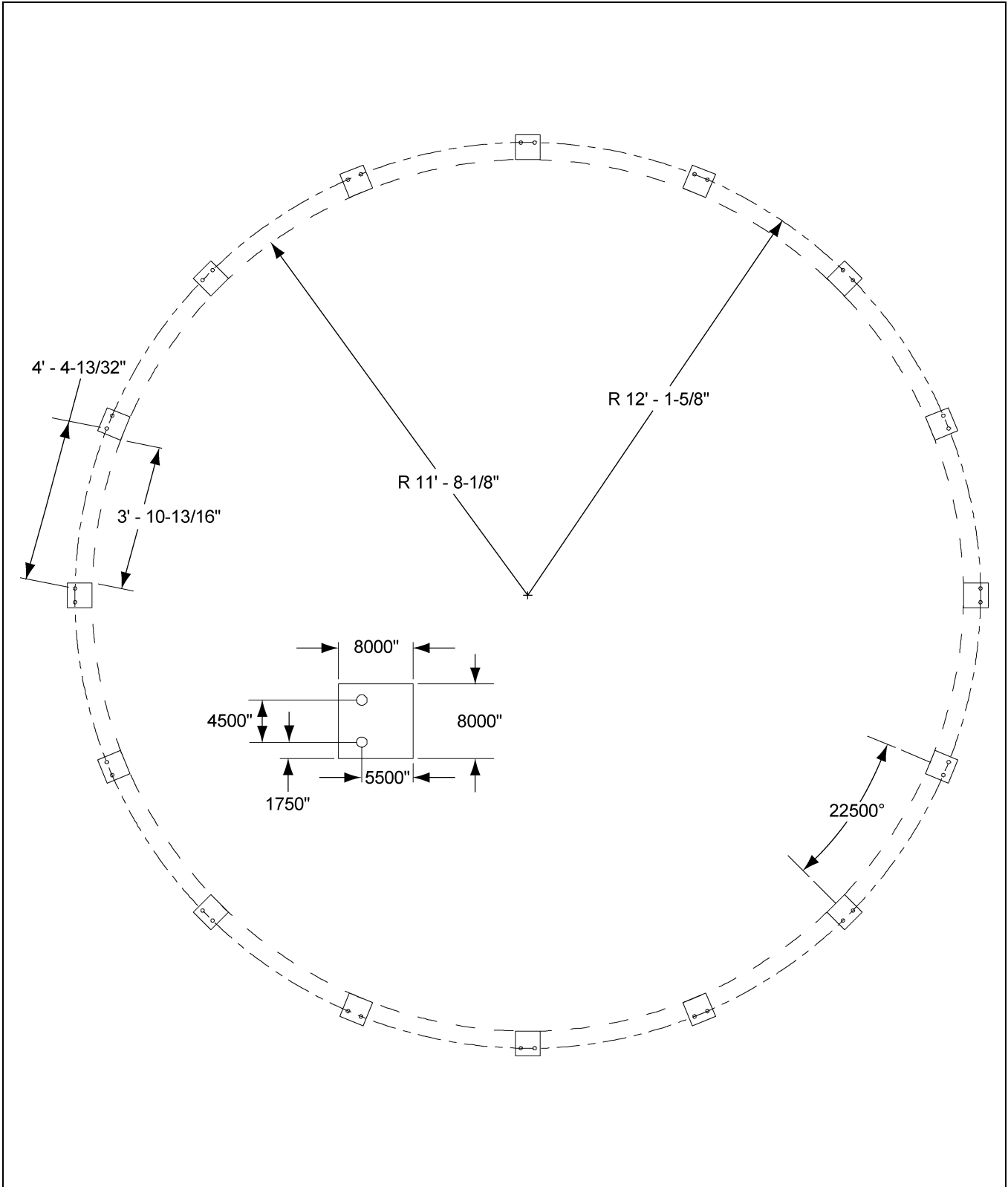

Figure 4E

24' Diameter FCHT Foundation

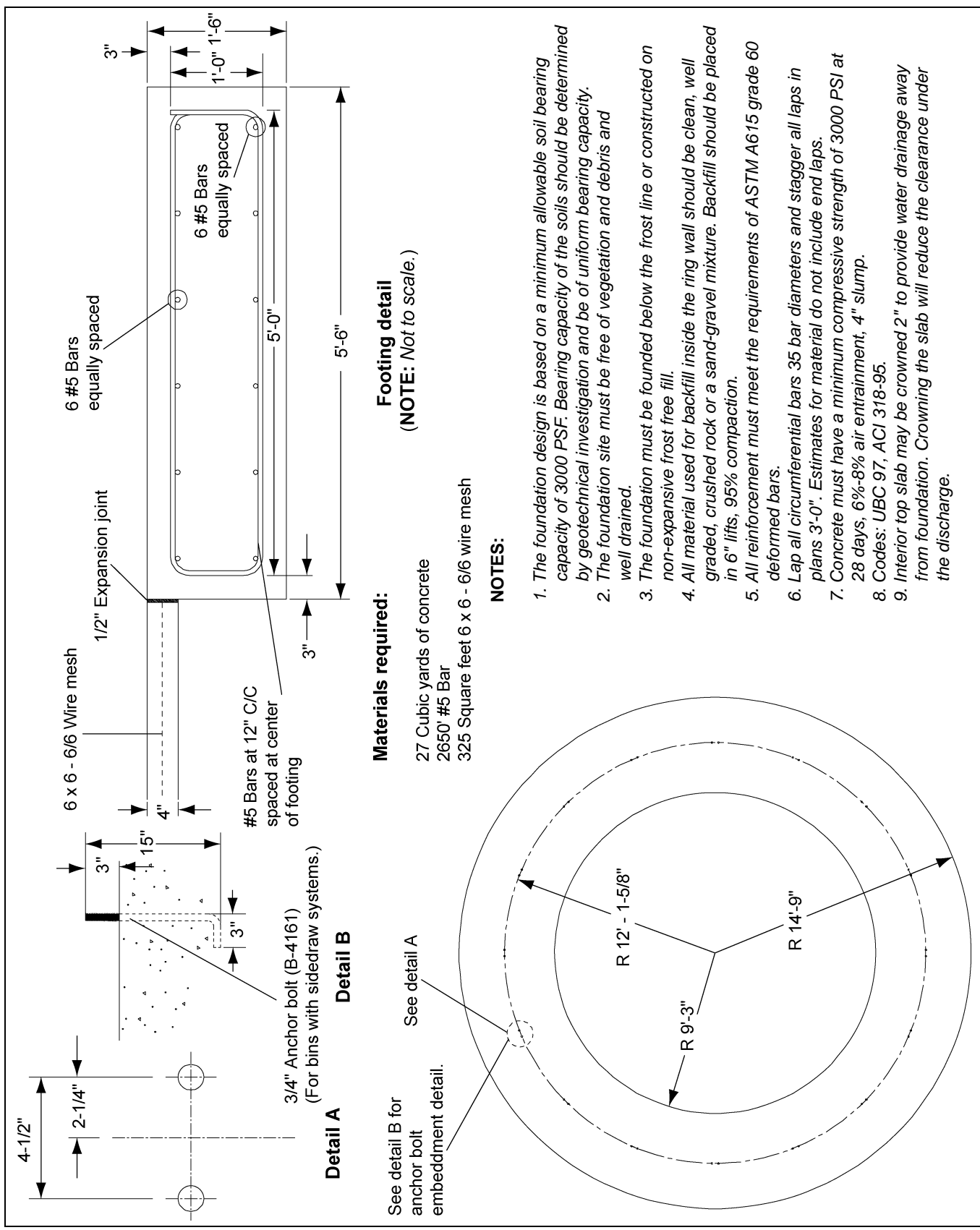

Figure 4F

5. FCHT Substructure

FCHT Parts List for Substructure

FCHT Substructure Parts List			
Tank Size	18'-45°	21'-45°	24'-45°
Color Code	Gold and White	Gold and Brown	Gold and Light Blue
Column Weldment	LCHT-0030 (12)	LCHT-0043 (14)	LCHT-0116 (16)
Compression Weldment	LCHT-0209 (12)	LCHT-0211 (14)	LCHT-0121 (16)
Compression Splice **	LCHT-0032 (12)	LCHT-0045 (14)	LCHT-0008 (16)
Hopper Collar	LCHT-0037 (1)	LCHT-0050 (1)	LCHT-0026 (1)
Horizontal Brace	LCHT-0011 (24)	LCHT-0011 (28)	LCHT-0011 (32)
Diagonal Brace	LCHT-0033 (48)	LCHT-0046 (56)	LCHT-0046 (64)
Right Hopper Panel	LCHT-0034 (12)	LCHT-0047 (14)	LCHT-0012 (16)
Left Hopper Panel	LCHT-0035 (12)	LCHT-0048 (14)	LCHT-0013 (16)
Support Hardware	LCHT-0038 (1)	LCHT-0051 (1)	LCHT-0022 (1)
Base Angle Shim **	LCHT-0014 (12)	LCHT-0014 (14)	LCHT-0014 (16)
Column Shim Plate **	LCHT-0015 (60)	LCHT-0015 (70)	LCHT-0015 (80)

** Indicates components that will be found in the support hardware.

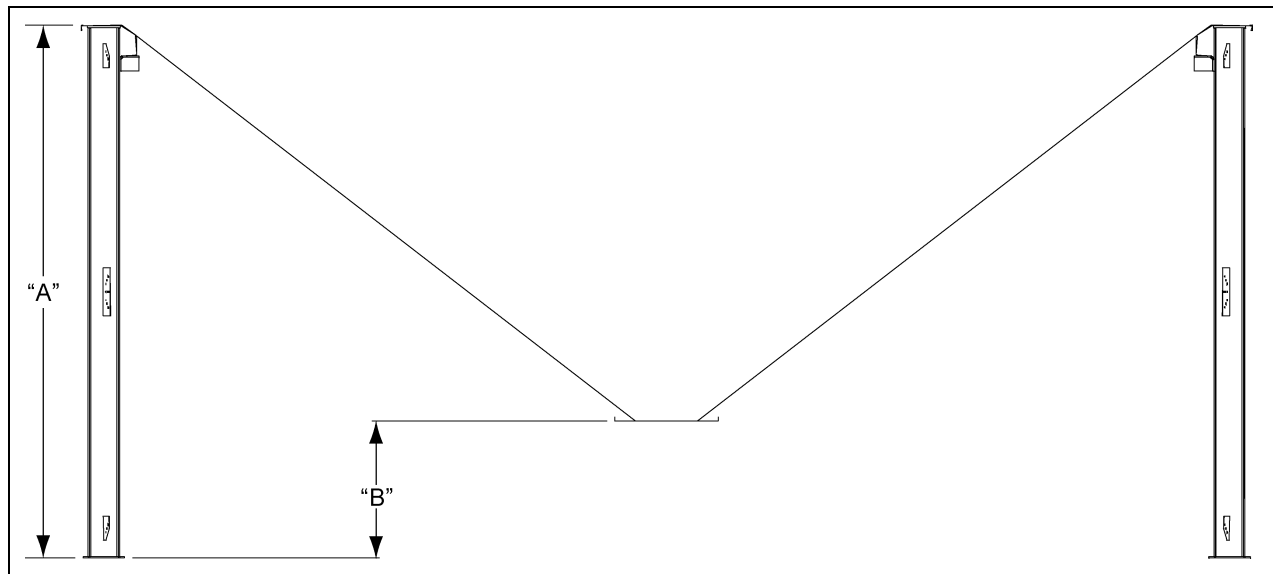

Figure 5A

Tank Size Diameter	Hopper Slope	"A" Dimension		"B" Dimension	
		Feet	Meters	Inches	Millimeters
18'	45	11' - 1-3/16"	3.383	34"	864
21'	45	12' - 5-3/16"	3.789	32"	813
24'	45	13'-5"	4.089	31"	787

Typical FCHT Column

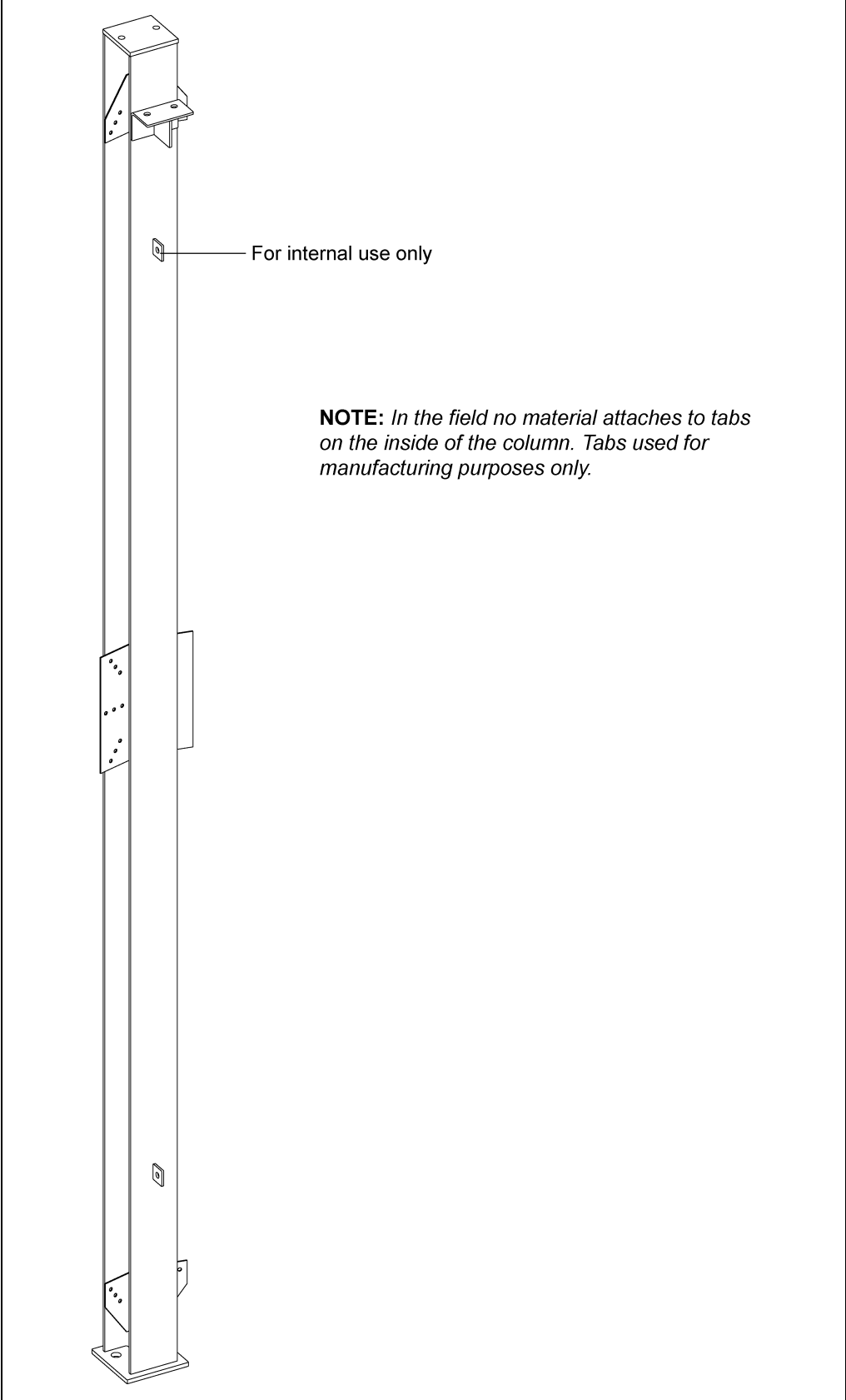

Figure 5B

6. Hopper Assembly

Hopper Section Assembly 18'-24' (5.49 m-7.32 m) Diameter Hopper Tank

Before placing the support columns on the anchor bolts, use a transit and surveyors rod to locate high and low areas in the concrete. To assure level alignment for the support columns, use the proper supplied shim or shims between the concrete and base plate. After leveling is completed, place the support columns over the anchor bolts, on the shims and loosely fasten with nuts and washers (not furnished). (See Figure 6A.)

NOTE: 18' (5.49 m) Diameter hopper tanks have 12 columns.

21' (6.40 m) Diameter hopper tanks have 14 columns.

24' (7.32 m) Diameter hopper tanks have 16 columns.

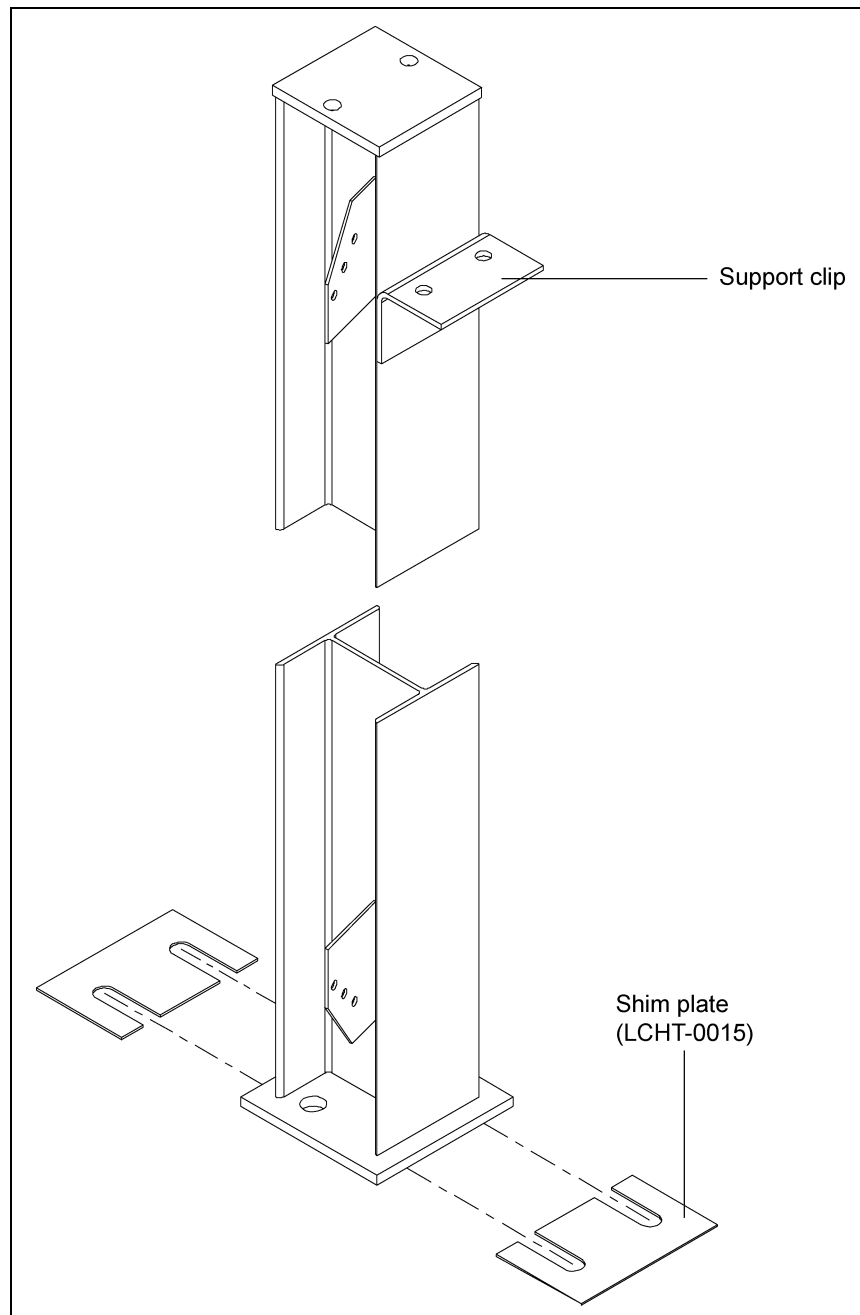

Figure 6A

Hopper Support System Layout

Connect hopper support column bracing as depicted in [Figure 6B](#). Use $\frac{3}{8}$ " x 1" hex flange head bolts for all bracing connections. The horizontal brace consist of two (2) formed channels placed back to back. Connect diagonal braces at their intersection with one $\frac{3}{8}$ " x 1" hex flange head bolt. The compression elements can be placed on the top of the column while the bracing is being installed. To ease construction pre-install a compression splice on the end of each compression element ($\frac{3}{8}$ " x 1" hex flange head bolts). Compression elements are connected to column supports clips with a $\frac{5}{8}$ " x 1- $\frac{1}{2}$ " hex bolt at each end. The compression element can be connected to column top plate at this time for alignment, however this bolt will have to be removed before the tank is set on the hopper support structure. Connect adjacent compression elements with compression splices.

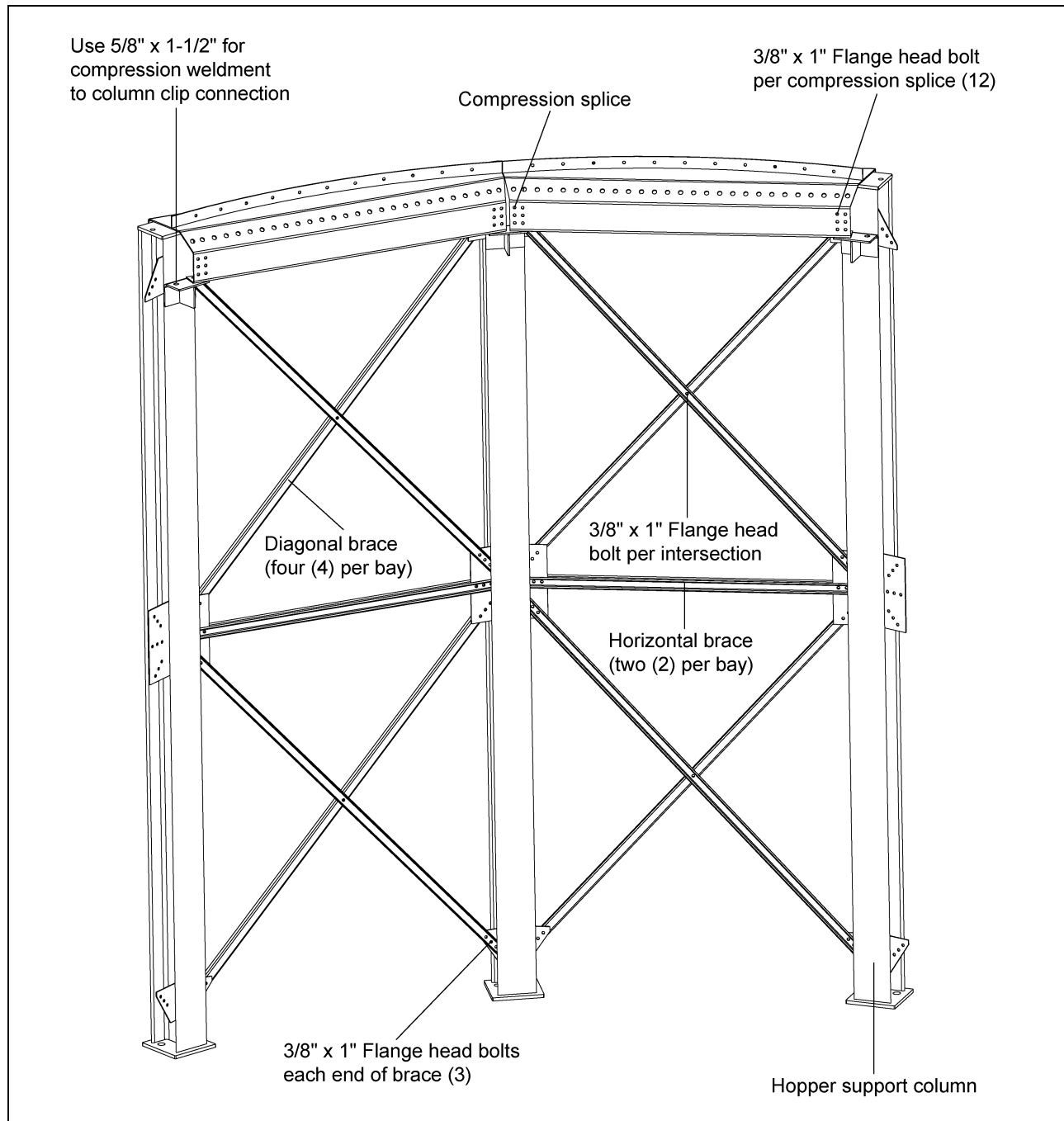

Figure 6B

6. Hopper Assembly

Hopper Bottom

Begin assembling the hopper bottom by attaching a right and left pair or pairs of hopper panels to the compression angle ring ($5/8"$ x $1-1/2"$ hex head bolts) and discharge collar ($3/8"$ x $1"$ hex flange head bolts) at four (4) opposing points. (See Figure 6F.) The left and right hopper panels can be assembled ($3/8"$ x $1"$ hex flange head bolts) prior to attachment to the compression ring. Caulking is required on the vertical seams of the lapped hopper panels. (See Figure 6C.) Complete assembly by positioning pairs of right and left hopper panels while moving around in one direction and lapping all sheets in the same way. (See Figure 6D.) Do not tighten bolts until all hopper panels are attached to each other, the compression ring and discharge collar. When ready to tighten, start at the bottom of the hopper and tighten all bolts. This will include hopper panels bolts, hopper collar bolts, compression ring bolts, compression splice bolts, column bracing bolts and anchor bolts.

NOTE: All bolts used in hopper assembly should be installed with the bolt heads to the inside of the hopper.

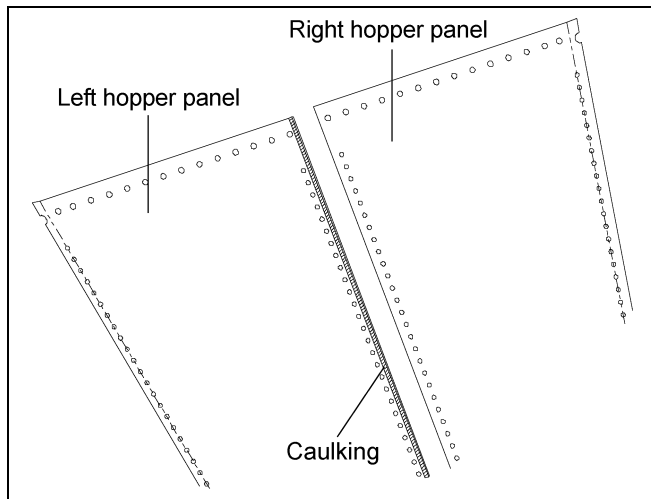

Figure 6C Caulking Detail

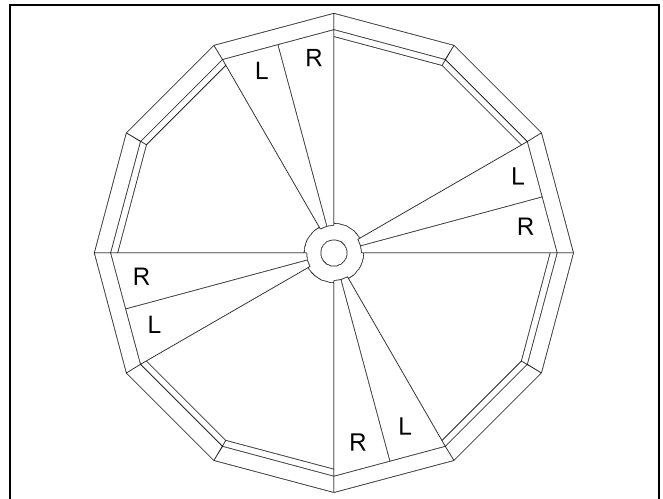

Figure 6F Hopper Panel and Discharge Collar Assembly

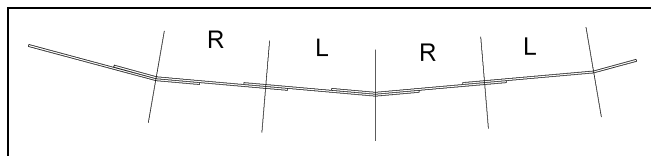

Figure 6D Lap Detail (Viewed from Inside of Bin)

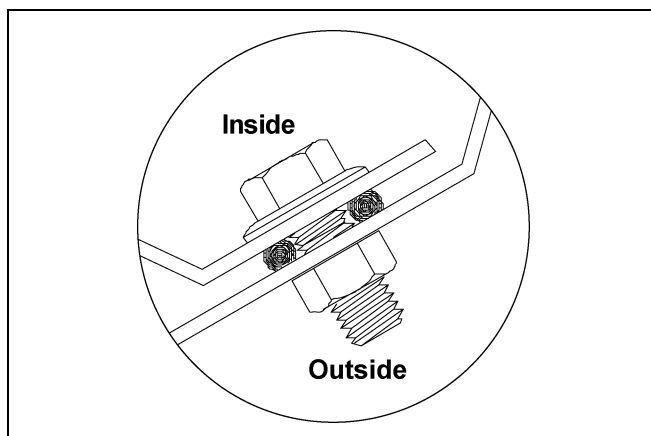

Figure 6E

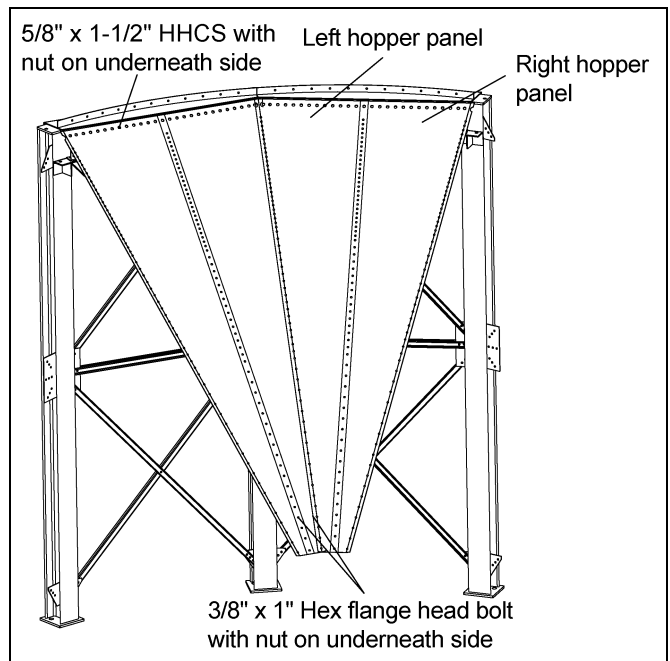

Figure 6G Hopper Panel Detail

Rack and Pinion

If a rack and pinion gate is purchased, install as shown in [Figure 6H](#) using 5/16" x 3/4" hardware.

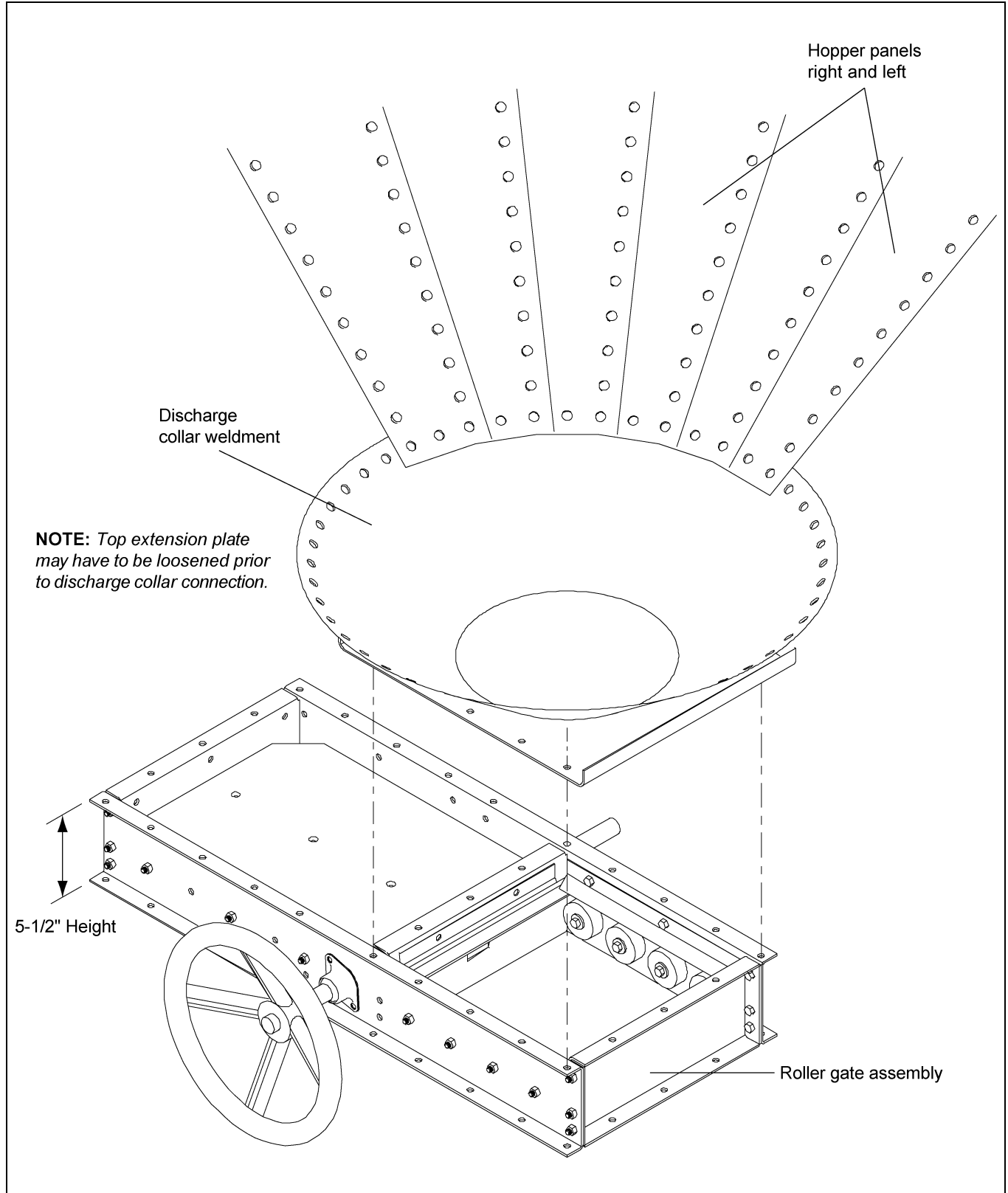

Figure 6H Hopper Discharge Collar to Roller Gate

Identifying Bolt Grades



Under no condition shall any other bolts be substituted for those supplied by the manufacturer.

Grade 2 Bolts

- Grade 2 bolts are designated with a plain head. Grade 2 bolts will not be used in a GSI grain Bin.

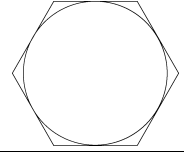

Grade 5 Bolts

- Grade 5 bolts are designated by three (3) slash marks on the head. All 5/16" diameter bolts are to be Grade 5 or higher.

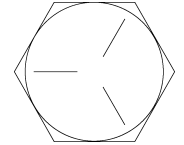

Grade 8 Bolts

- Grade 8 bolts are designated by six (6) slash marks evenly spaced out around the head of the bolt.

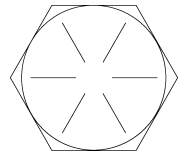

Grade 8.2 Bolts

- Grade 8.2 bolts are designated by six (6) slash marks on the head in a sunrise pattern. All 3/8" diameter bolts are to be Grade 8 or 8.2.

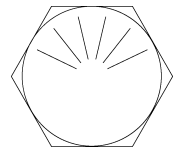

NOTE: Do not tighten bolts to exceed the torque specifications listed in the [below](#) chart.

Bolt Size	Torque (Ft. Lbs.)	
	Minimum	Maximum
5/16"-18	15	20
3/8"-16	35	42
7/16"-14	65	72
1/2"-13	95	105

IMPORTANT: Hardware usage - 20 Gauge - 14 Gauge sidewall sheets, use 5/16" x 3/4" bolts and nuts (S-7482).

13 Gauge sidewall sheets, use 3/8" x 1" bolts and nuts (S-7487).

Bolting Requirements

FCHT Stiffener Hardware		Splice Connections are Figured for the Top of the Stiffener Splices.	
16 Gauge (2 Stiffeners per Sheet) [(22) S-7482 per Sheet] [(22) S-10268 per Sheet]	Splice Bolting	Per Splice	
		6	S-7485 3/8" x 1" Flange Bolts
	Stiffener to Sidewall Bolting	6	S-9426 3/8" Flange Nuts
		Per Sheet	
		22	S-7482 5/16" x 3/4" Flange Bolts
		22	S-10268 5/16" Flange Nuts
14 Gauge (2 Stiffeners per Sheet) [(22) S-7482 per Sheet] [(22) S-10268 per Sheet]	Splice Bolting	Per Splice	
		8	S-7485 3/8" x 1" Flange Bolts
	Stiffener to Sidewall Bolting	8	S-9426 3/8" Flange Nuts
		Per Sheet	
		22	S-7482 5/16" x 3/4" Flange Bolts
		22	S-10268 5/16" Flange Nuts
12 Gauge (2 Stiffeners per Sheet) [(22) S-7482 per Sheet] [(2) S-7483 per Sheet] [(22) S-10268 per Sheet]	Splice Bolting	Per Splice	
		8	S-7485 3/8" x 1" Flange Bolts
	Stiffener to Sidewall Bolting	8	S-9426 3/8" Flange Nuts
		Per Sheet	
		22	S-7482 5/16" x 3/4" Flange Bolts
		2	S-7483 5/16" x 1-1/4" Flange Bolts
22	S-10268 5/16" Flange Nuts		

Transitionals		Splice Connections are Figured for the Top of the Stiffener Splices.	
12 Gauge to 10 Gauge (2 Stiffeners per Sheet) [(20) S-7482 per Sheet] [(2) S-7483 per Sheet] [(22) S-10268 per Sheet]	Splice Bolting	Per Splice	
		8	S-7485 3/8" x 1" Flange Bolts
	Stiffener to Sidewall Bolting	8	S-9426 3/8" Flange Nuts
		Per Sheet	
		20	S-7482 5/16" x 3/4" Flange Bolts
		2	S-7483 5/16" x 1-1/4" Flange Bolts
22	S-10268 5/16" Flange Nuts		
10 Gauge Transitional to 8 Gauge 8 Gauge to 8 Gauge Add (1) FC-42076 per Connection [(18) S-7482 per Sheet] [(4) S-7483 per Sheet] [(4) S-10268 per Sheet]	Splice Bolting	Per Splice	
		12	S-7485 3/8" x 1" Flange Bolts
	Stiffener to Sidewall Bolting	12	S-9426 3/8" Flange Nuts
		Per Sheet	
		18	S-7482 5/16" x 3/4" Flange Bolts
		4	S-7483 5/16" x 1-1/4" Flange Bolts
22	S-10268 5/16" Flange Nuts		

7. Hardware

FCHT Sidewall Hardware **		Refer to Stiffener Sheets for Stiffener to Sidewall Hardware Usage.	
20 Gauge to 15 Gauge	56	S-7482	5/16" x 3/4" Flange Bolts
	56	S-396	5/16" Hex Nuts
	7	S-4458	Caulking (24' Roll)
14 Gauge	68	S-7482	5/16" x 3/4" Flange Bolts
	68	S-396	5/16" Hex Nuts
	7	S-4458	Caulking (24' Roll)

** For stiffener to sidewall quantities, see stiffener hardware [on Page 29](#).

Bolting Requirements 2 Stiffeners per Sidewall Sheet

Sidewall Gauge	Horizontal Seam *	Vertical Seam	Stiffener to Sidewall **	Overlap Seam
15 through 20	5/16" x 3/4" [10]	5/16" x 3/4" [42]	5/16" x 3/4" [20]	5/16" x 3/4" [2]
14	5/16" x 3/4" [22]	5/16" x 3/4" [42]	5/16" x 3/4" [20]	5/16" x 3/4" [2]
10 through 13	3/8" x 1" [22]	3/8" x 1" [42]	5/16" x 1-1/4" [20]	5/16" x 1-1/4" [2]

All bolts are standard bin bolts with neoprene washers. For horizontal and vertical seam bolts, the bolt head and neoprene washers are on the outside of the bin.

* **NOTE:** For the splice plates FC-42076 and 12 gauge and thicker stiffener overlaps use 5/16" x 1-1/4" bolts for the stiffener to sidewall connections.

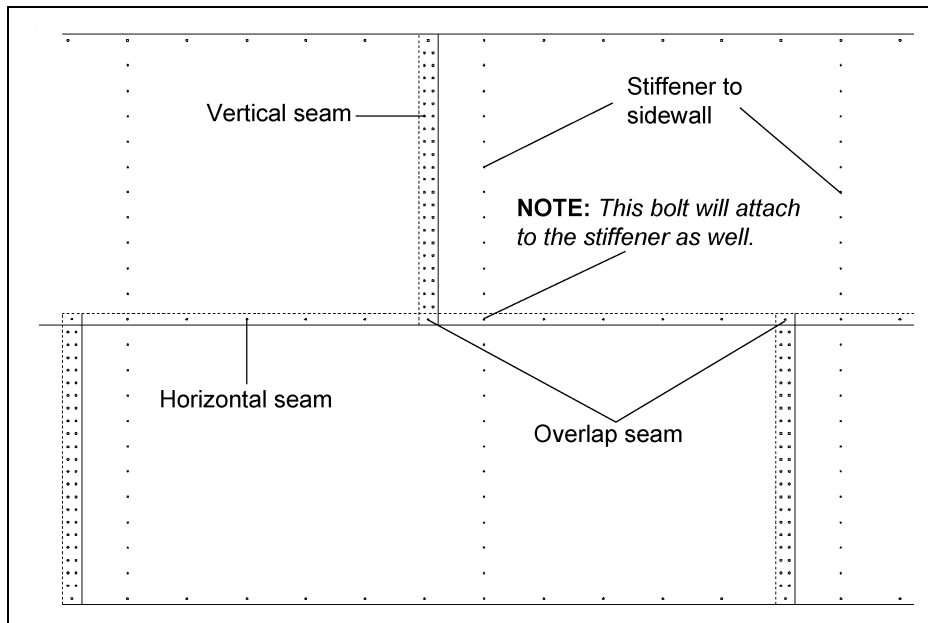
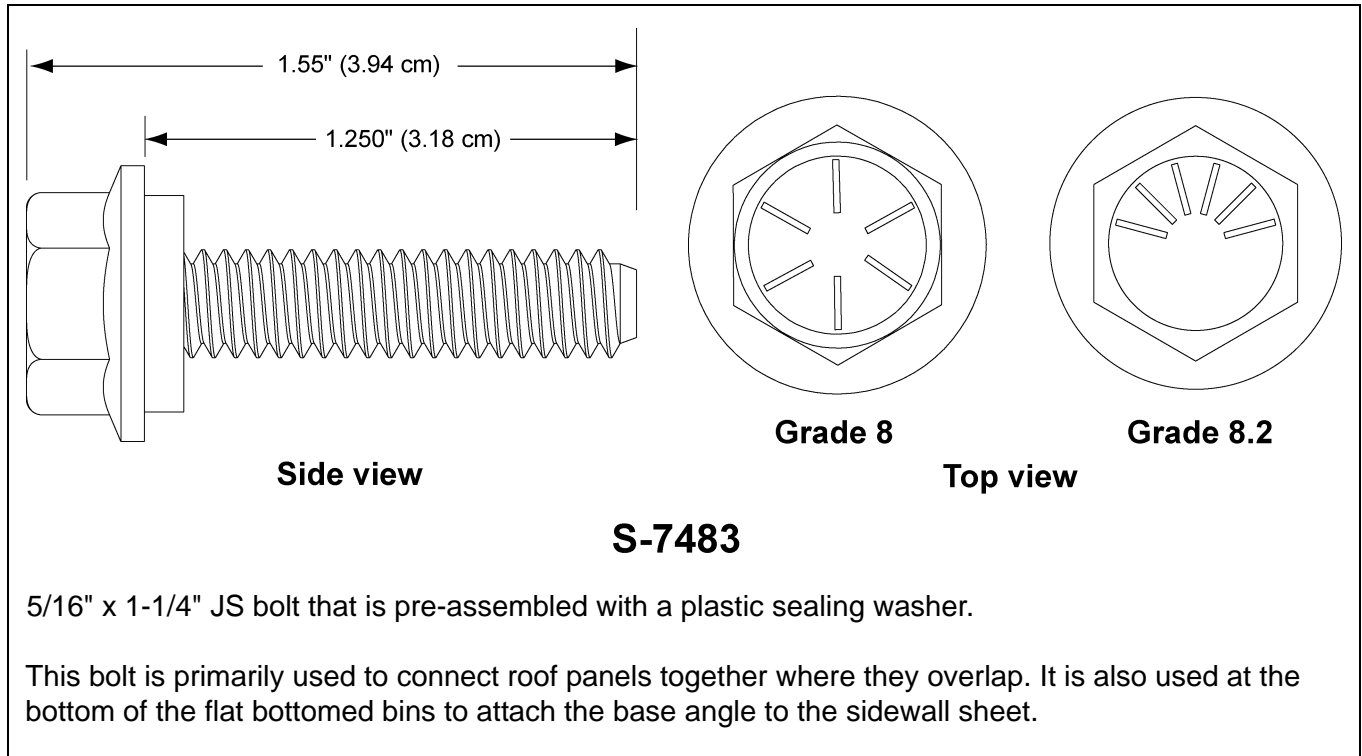
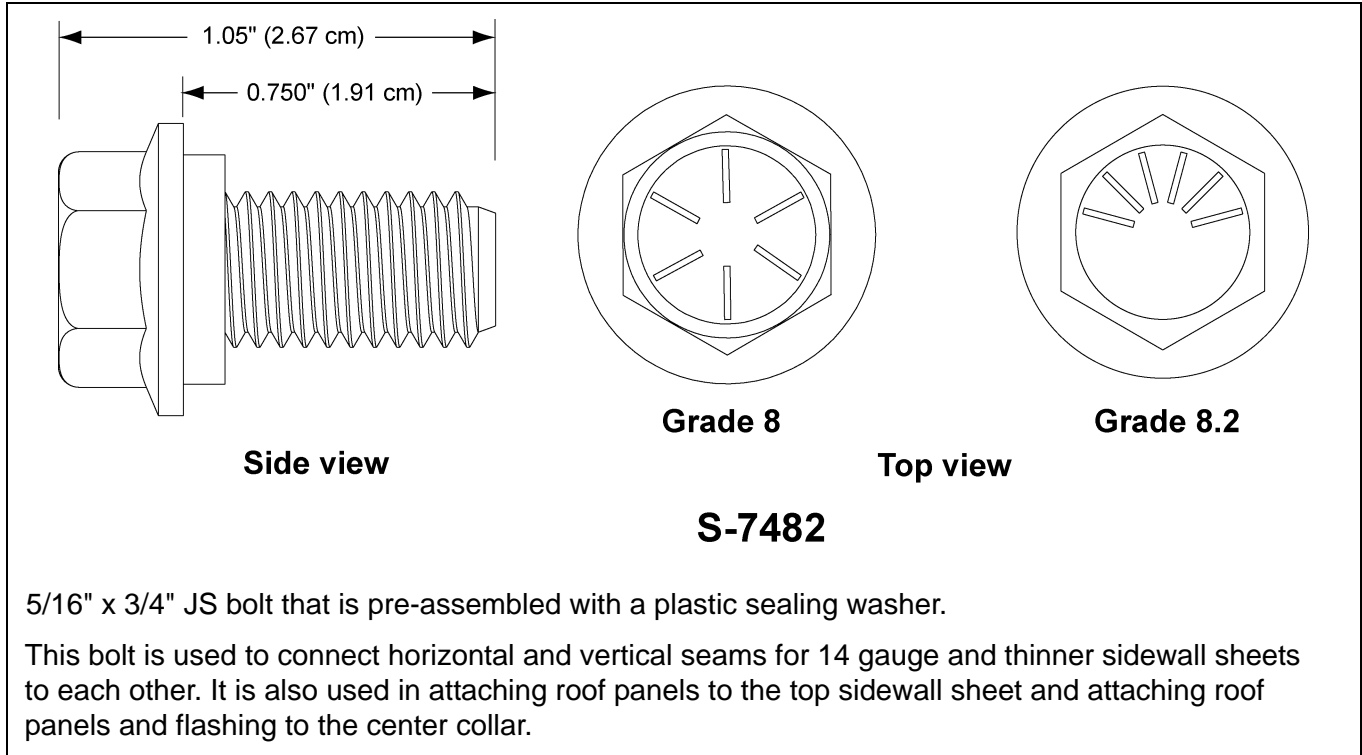

Figure 7A Standard Sheet Bolting Detail (Viewed from Outside of the Bin)

Bolt Usage

(Refer to [Page 28](#) for complete bolt usage.)



Bolt Usage (Continued)

(Refer to [Page 28](#) for complete bolt usage.)

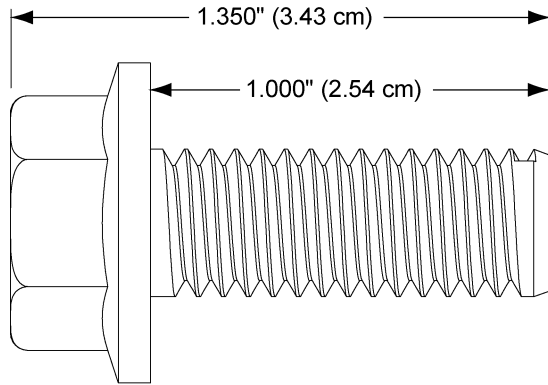

Side view

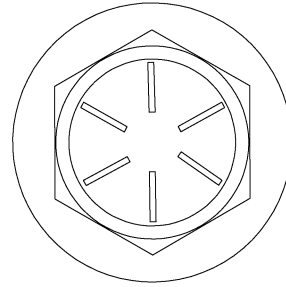

Grade 8

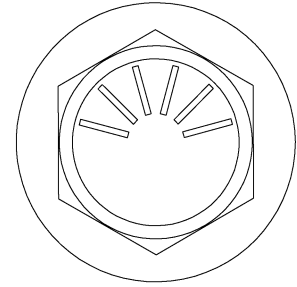

Grade 8.2

Top view



















S-7485

3/8" x 1" JS hex bolt with flanged head and **without** a sealing washer.

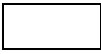
This bolt is used to splice the stiffeners together on the flanges. A flange nut is used on the nut side of the connection. They are also used on the roof rafter splices for commercial roof systems.

Color Chart for Bin Hardware Bucket Lids

For ease of identification, hardware is separated and identified by buckets with color coded lids. Use the following chart to help identify the correct hardware.

JS Part #	YDP Part #	Color	Bucket Count	Lid Color	Description
S-7482	S-275	Dark Blue	1500		5/16" x 3/4" Bolt pre-assembled with sealing washer
NA	S-10260	Lime Green	1250		5/16" x 1" Bolt pre-assembled with sealing washer
S-7483	S-277	Black	1000		5/16" x 1-1/4" Bolt pre-assembled with sealing washer
S-7484	S-396	Red	5000		5/16" Hex nut
S-10268	S-3611	Gold	NA		5/16" Flange nut
S-7487	S-455	Grey	850		3/8" x 1" Bolt pre-assembled with sealing washer
S-7485	S-7927	Light Green	1000		3/8" x 1" Flanged bolt without sealing washer
S-7488	S-5060	Orange	650		3/8" x 1-1/2" Bolt pre-assembled with sealing washer
S-7486	S-7928	Dark Brown	700		3/8" x 1-1/2" Flange bolt without sealing washer
S-10165	S-9445	Light Blue	500		3/8" x 2" Bolt pre-assembled with sealing washer
S-7489	S-456	Yellow	4000		3/8" Hex nut
S-9426	S-9373	Dark Purple	2500		3/8" Hex flanged nut
NA	S-10250	NA	NA	In Box	7/16" x 1-1/4" Flanged bolt
S-10262	S-9464	White	500		7/16" x 1-1/2" Flange bolt pre-assembled with sealing washer
S-9389	S-10114	Light Purple	350		7/16" x 2" Bolt pre-assembled with sealing washer
S-10134	S-9444	Dark Green	300		7/16" x 2-1/2" Bolt pre-assembled with sealing washer
S-10261	NA	Natural (Clear)	200		7/16" x 3-1/4" Flange bolt pre-assembled with sealing washer
S-9281	S-7332	Fire Orange	1500		7/16" Hex nut
NA	S-8479	Light Brown	800		7/16" Special recessed nut
NA	S-10251	NA	NA	In Box	7/16" Un-serrated flange nut
NA	S-10252	NA	NA	In Box	1/2" x 1-3/4" Flange bolt
NA	S-10253	NA	NA	In Box	1/2" Un-serrated flange nut

8. FCHT Gauge Charts

Standard catalog FCHT gauges are provided [on Pages 34 and 35](#). These tanks utilize the designation FCHTxxx45F. For example, a 24', 9 ring FCHT part number is FCHT24-945F.

If you have a special FCHT, for example, any tank other than standard, you must reference a gauge sheet for the tank. This sheet will normally be attached to the front of this manual.

Should it not be attached to this manual, you MUST contact GSI for the proper gauge sheet.

FCHT Series - 4.00" Corrugation 18' Diameter Sidewall and Stiffener Gauge Chart

Sidewall Ring #		1	2	3	4	5	6	7	8	9
9	Sidewall Gauge	20	20	20	18	18	17	16	15	15
	Stiffener Gauge	16	16		14		10		8	
8	Sidewall Gauge	20	20	20	18	18	17	16	15	
	Stiffener Gauge	16		16		12		10		
7	Sidewall Gauge	20	20	20	18	18	17	16		
	Stiffener Gauge	16	16		14		10			
6	Sidewall Gauge	20	20	20	18	18	17			
	Stiffener Gauge	16		16		14				
5	Sidewall Gauge	20	20	20	18	18				
	Stiffener Gauge	16	16		14					
4	Sidewall Gauge	20	20	20	18					
	Stiffener Gauge	16		16						

of Stiffener Columns: 12

NOTE: 1 Ring door weldment in second ring from bottom of tank.

All specifications subject to change without notification.

FCHT Series - 4.00" Corrugation 21' Diameter Sidewall and Stiffener Gauge Chart

Sidewall Ring #		1	2	3	4	5	6	7	8	9
9	Sidewall Gauge	20	20	20	18	17	16	15	15	14
	Stiffener Gauge	16	14		12		10		8	
8	Sidewall Gauge	20	20	20	18	17	16	15	15	
	Stiffener Gauge	16		14		12		10		
7	Sidewall Gauge	20	20	20	18	17	16	15		
	Stiffener Gauge	16	14		12		10			
6	Sidewall Gauge	20	20	20	18	17	16			
	Stiffener Gauge	16		14		12				
5	Sidewall Gauge	20	20	20	18	17				
	Stiffener Gauge	16	14		12					
4	Sidewall Gauge	20	20	20	18					
	Stiffener Gauge	16		14						

of Stiffener Columns: 14

NOTE: 1 Ring door weldment in second ring from bottom of tank.

All specifications subject to change without notification.

FCHT Series - 4.00" Corrugation 24' Diameter Sidewall and Stiffener Gauge Chart

Sidewall Ring #		1	2	3	4	5	6	7	8	9
9	Sidewall Gauge	20	20	20	18	17	16	15	14	14
	Stiffener Gauge	16	14		12		10		8	
8	Sidewall Gauge	20	20	20	18	17	16	15	14	
	Stiffener Gauge	16		14		12		10		
7	Sidewall Gauge	20	20	20	18	17	16	15		
	Stiffener Gauge	16	14		12		10			
6	Sidewall Gauge	20	20	20	18	17	16			
	Stiffener Gauge	16		14		12				
5	Sidewall Gauge	20	20	20	18	17				
	Stiffener Gauge	16	14		12					
4	Sidewall Gauge	20	20	20	18					
	Stiffener Gauge	16		14						

of Stiffener Columns: 16

NOTE: 1 Ring door weldment in second ring from bottom of tank.

All specifications subject to change without notification.

Sidewall Erection Instructions

Gauge Color Code

1. Before bolting the sidewall sheets together, check that you have the proper gauge steel for the first ring. The higher gauge numbers denote the thinner materials. *(For example, 20 gauge material is thinner than 14 gauge.)*
2. In erecting most grain bins the thinnest material usually goes on top, therefore the first sidewall ring you assemble will be the top ring of the bin.
3. Check the various gauges of the bin with the color code chart and begin building accordingly.
REMEMBER..... Assemble the top ring first.

Gauge	Color Code
20	Red
19	Black/Yellow
18	Orange
17	Pink/Light Blue
16	Blue
15	Brown/Red
14	Green
13	Yellow/Blue
12	Black
11	Pink
10	Light Blue
9	Blue/Orange
8	Yellow

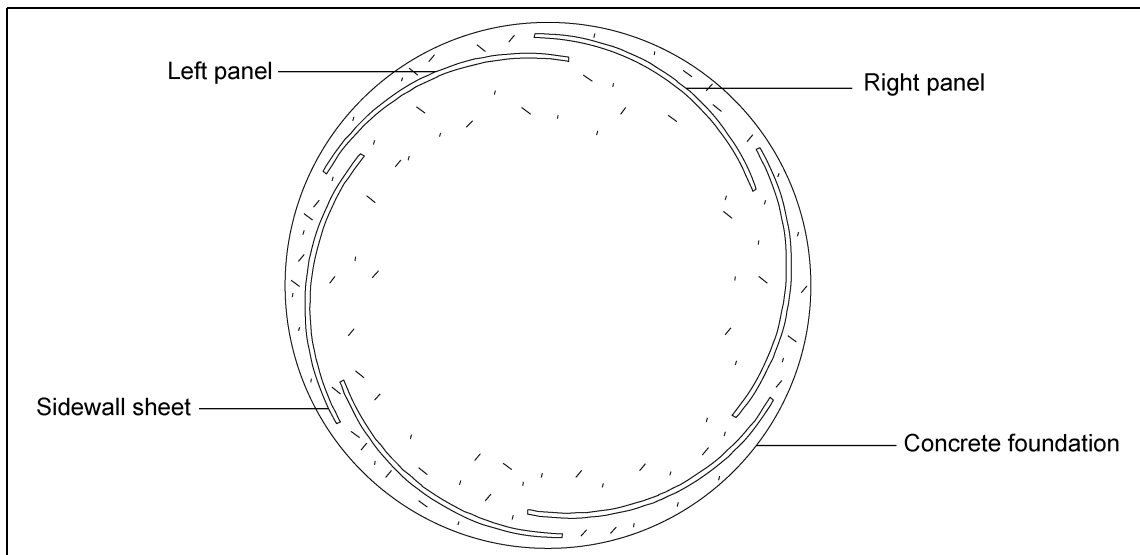

Figure 9A

Sidewall Erection Instructions (Continued)

NOTE: The rope caulking is installed before each sheet is assembled. Apply rope caulking between the last vertical row of bolts and edge of outside sheet. There is sufficient caulking for all vertical seams on storage and drying bins. Wipe sheet clean where caulking is to be applied.

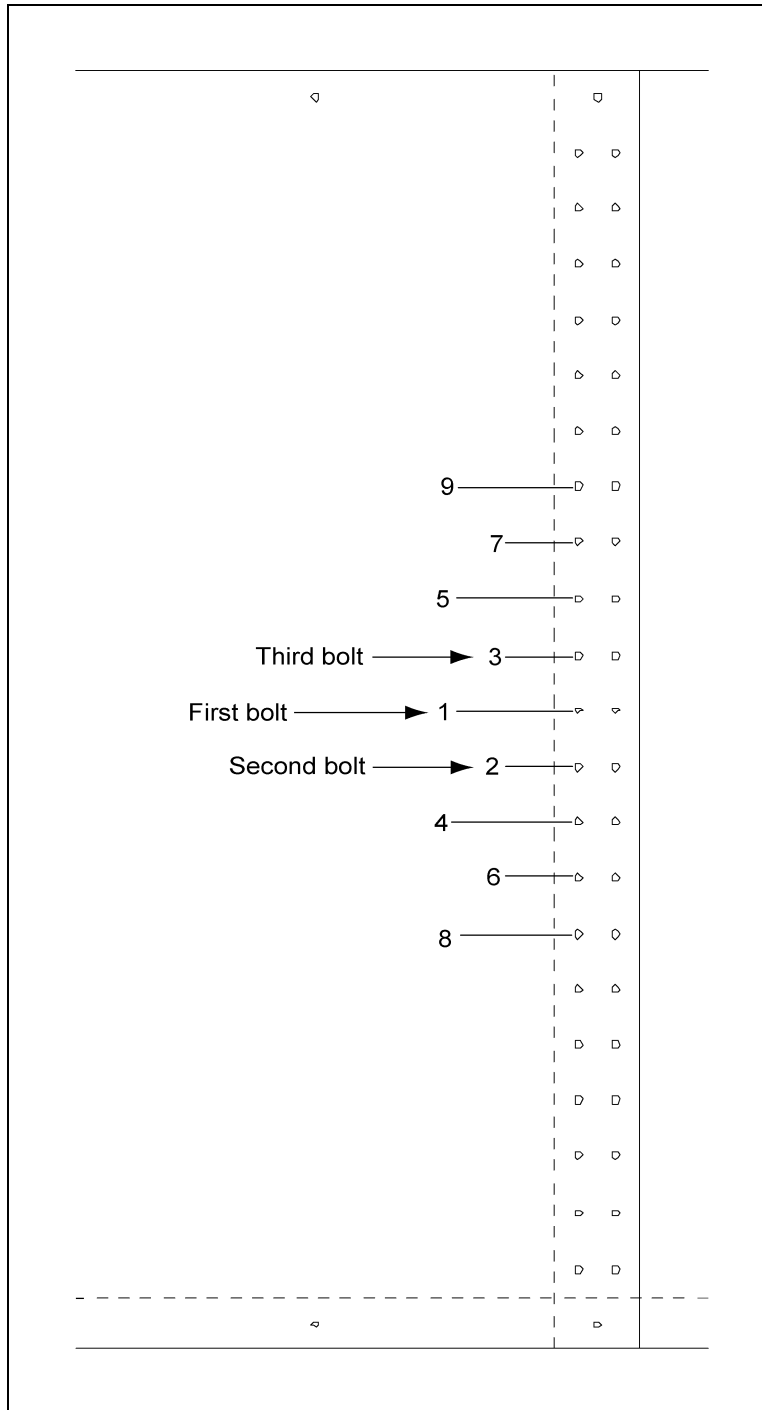

Figure 9B Tighten Bolts in Order

9. Sidewall Assembly

Caulking and Bolting Sidewall Sheets

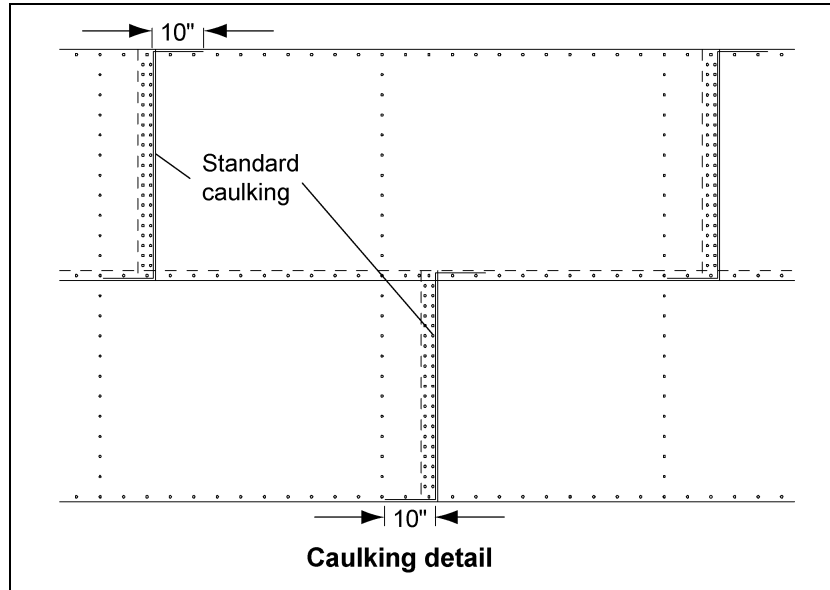

Figure 9C Standard Sidewall Sheets (As Viewed from Outside Bin)

1. Install rope caulk to each sheet before it is assembled. (See Figure 9C.)
2. Using correct size bin bolts throughout, begin assembling sidewall sheets end to end (overlapping the same way throughout) until the ring is completed. All body sheet bolts are to be installed with the bolt head and its neoprene washer to the outside and the nut on the inside. **Do not tighten bolts until all sheets are assembled and form a complete ring.**
3. Attach lifting brackets to stiffener bolt holes. These straps, coupled to the jacks will enable you to later elevate the bin.
4. Now tighten the bolts in sequence, starting from the center and working to the edge in both directions. This permits the sidewall sheets to draw-up evenly. Complete one ring and stop. (See Figure 9B on Page 37.) Tighten from the nut side.
5. You are now ready to assemble the roof. Refer to the roof erection manual for roof assembly instructions located in roof hardware box.

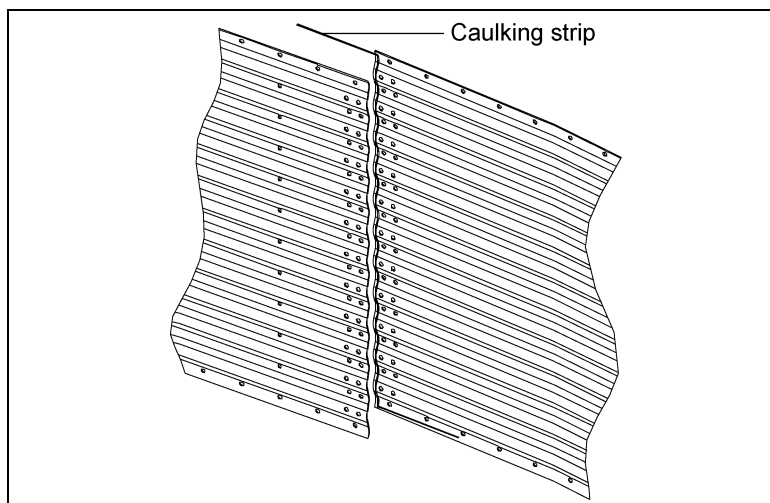

Figure 9D Standard Sidewall Sheets (As Viewed from Inside the Bin)

Lifting Jack Usage

General Lifting Jack Instructions

1. Give some thought before starting the bin, to the location of door and other accessories. Proper placement of lifting jacks in relationship to anchor bolts could make a difference on odd or even ring bins. Walk through door is centered between two (2) stiffener anchor bolts. The sidewall sheets are also staggered 1/2 from end to end.
2. Lifting brackets should be attached through the stiffener bolt holes. Normally you will need to attach to at least four (4) bolts per stiffener. Anchor all jacks securely with metal stakes and cable.
3. Now raise the bin just high enough to assemble the next ring. **When lifting the bin, crank all jacks at an equal rate.** This will prevent bowing previously assembled rings and make for easier hole alignment. (See Figure 10A.)
4. To the **inside** of the first ring, bolt the next ring. Be sure to **stagger** the sheets and select the proper gauge material.
5. Lower the bin onto the foundation after assembling and tightening bolts on the new ring or rings.
6. Now re-bolt the lifting straps to the lowest ring in place thus far. Continue ring additions until you are ready for door installation. **You may want to leave sheets loose to make the attachment of the stiffeners easier.**

NOTE: The number of lifting jacks required is best determined by personal experience. Factors such as bin size, soil compaction, wind velocity, jack design, etc., are all to be considered when deciding how many to use. If in doubt, use one jack on every vertical seam. Be sure to use heavy duty jacks for commercial installation.

NOTE: Add inside and outside ladders to bin walls as you continue to raise the bin. (Refer to the manual supplied with the ladder.)

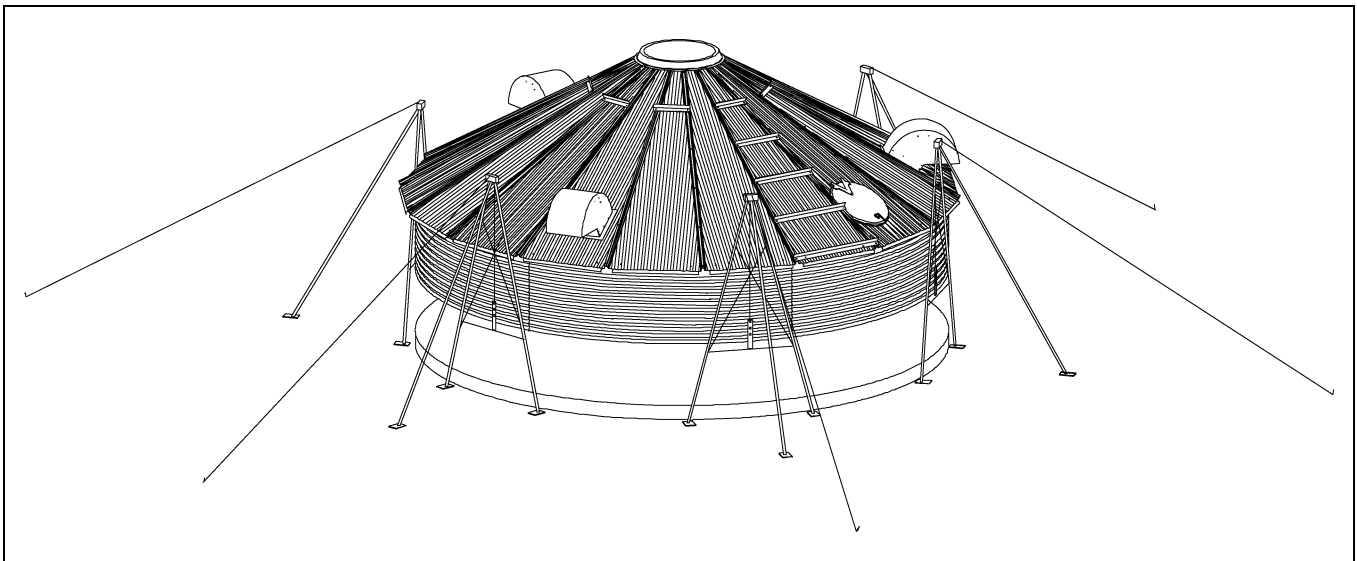

Figure 10A Lifting Jack

Top Stiffener Starting Location

Installing Stiffeners

All stiffeners are to be installed on the exterior of the bin. Be sure and use 5/16" x 3/4" grade 5 bin bolt with neoprene washer with the bolt head and washer on the inside of the grain bin. Refer to spread chart for proper location of stiffeners and sidewall sheets [on Pages 41-43. \(See Figure 11B.\)](#)

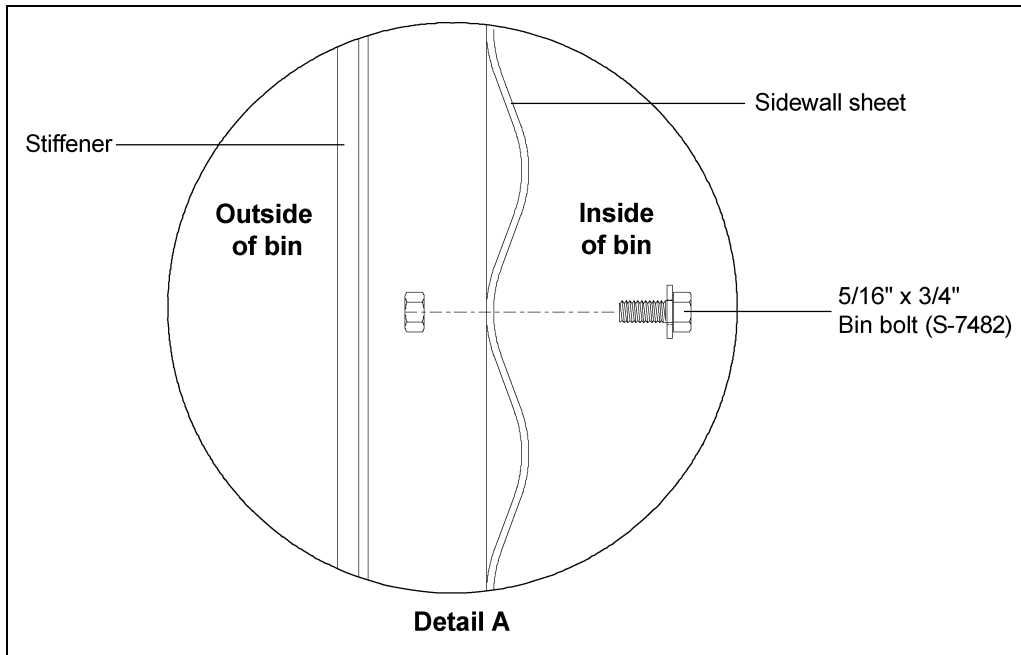

Figure 11A

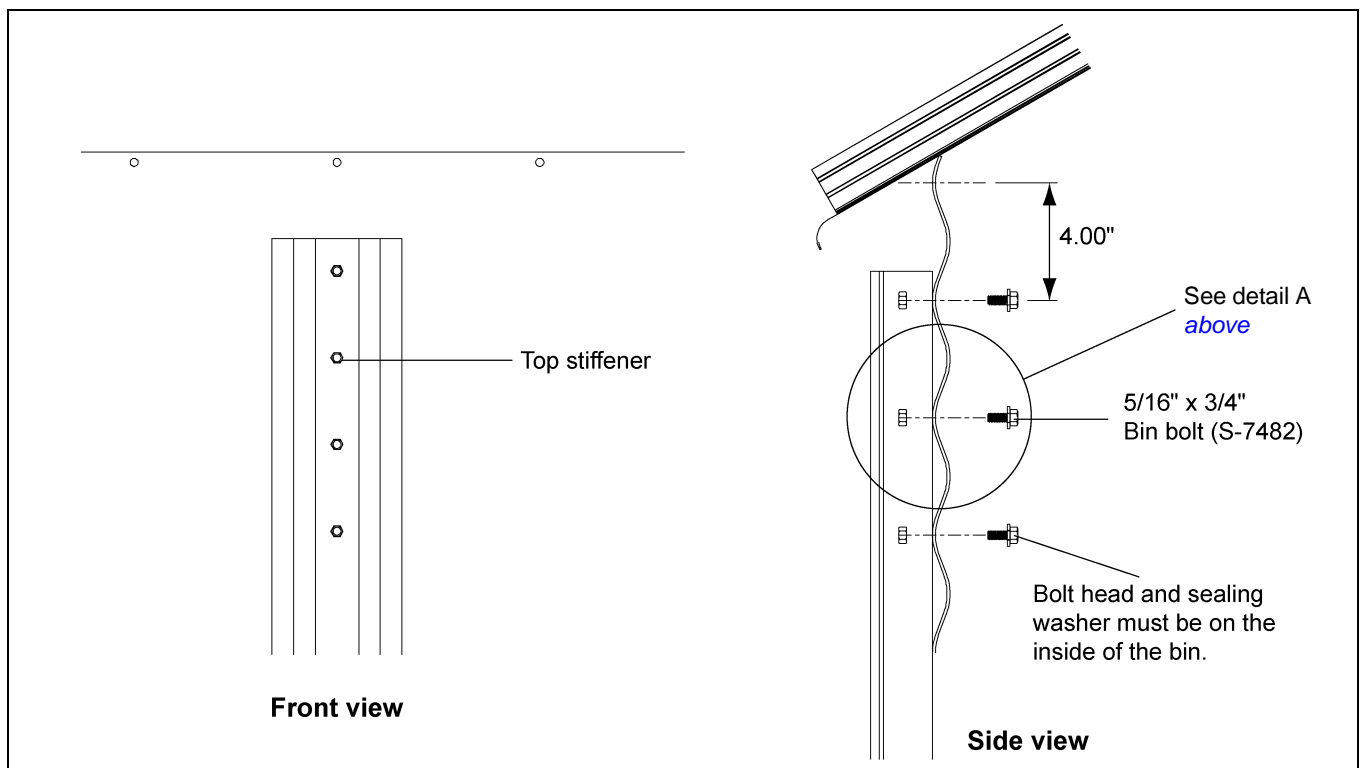

Figure 11B

FCHT Stiffeners

FCHT stiffeners will have an identifying part number stamped on the part.

* The XX in the part numbers at the bottom will identify the stiffener's gauge.

Example: FC-4205714 is a 2 ring standard stiffener 14 gauge.

Part #	Stiffener Description	Overall Length	Color Code
FC-4207210	2 Ring 10 Gauge (Base)	94-27/32"	White
FC-4207212	2 Ring 12 Gauge (Base)	94-27/32"	Black
FC-4207214	2 Ring 14 Gauge (Base)	94-27/32"	Green
FC-4207216	2 Ring 16 Gauge (Base)	93-13/16"	Blue
FC-4207308	2 Ring 8 Gauge (Base)	88-3/16"	Yellow
FC-4206308	2 Ring 8 Gauge	87-15/16"	Yellow
FC-42062	2 Ring 10 Gauge Transition	94-19/32"	Purple
FC-4205712	2 Ring 12 Gauge	94-19/32"	Black
FC-4205714	2 Ring 14 Gauge	94-19/32"	Green
FC-4207516	2 Ring 16 Gauge	93-9/16"	Blue
FC-4206516	2 Ring 16 Gauge Top	85-9/16"	Blue
FC-4205912	1 Ring 12 Gauge	50-19/32"	Black
FC-4205914	1 Ring 14 Gauge	50-19/32"	Green
FC-4207416	1 Ring 16 Gauge	49-9/16"	Blue
FC-4206616	1 Ring Top 16 Gauge	41-7/16"	Blue
FC-42076	Splice	10-11/16"	-

FCHT Stiffeners (Continued)

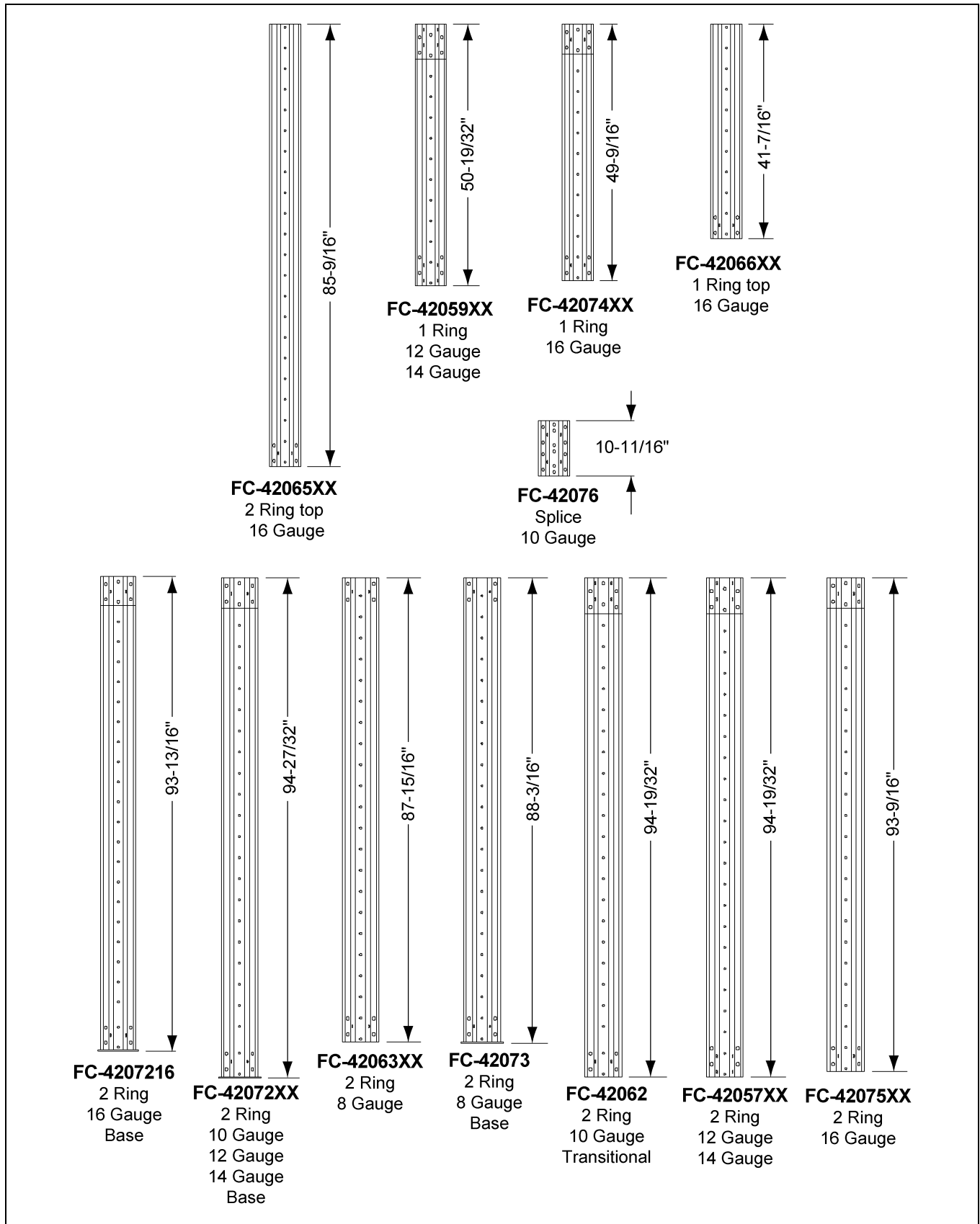

Figure 11C

Stiffener Splicing Details

Stiffener Splicing Instructions

1. When installing bottom stiffeners, you may find that in some cases the stiffeners with the base plates attached will not rest on the foundation (compression element). Shim plates have been furnished and should be used to fill any gaps between the base plates on the stiffeners and the compression element.
2. Stiffeners that are 10 gauge through 16 gauge (10, 12, 14 and 16 gauge) have an offset splice, these stiffeners are offset at the top. (See Figure 11D.)
3. When attaching the tops of 8 gauge stiffeners to the bottom of 8 gauge or 10 gauge stiffeners, use a separate splice plate (FC-42076). (See Figure 11E.)



If shim plates are not used where required, the downward pressure of the stiffeners will not be transferred directly to the foundation and bin failure could result.

Stiffener Splicing

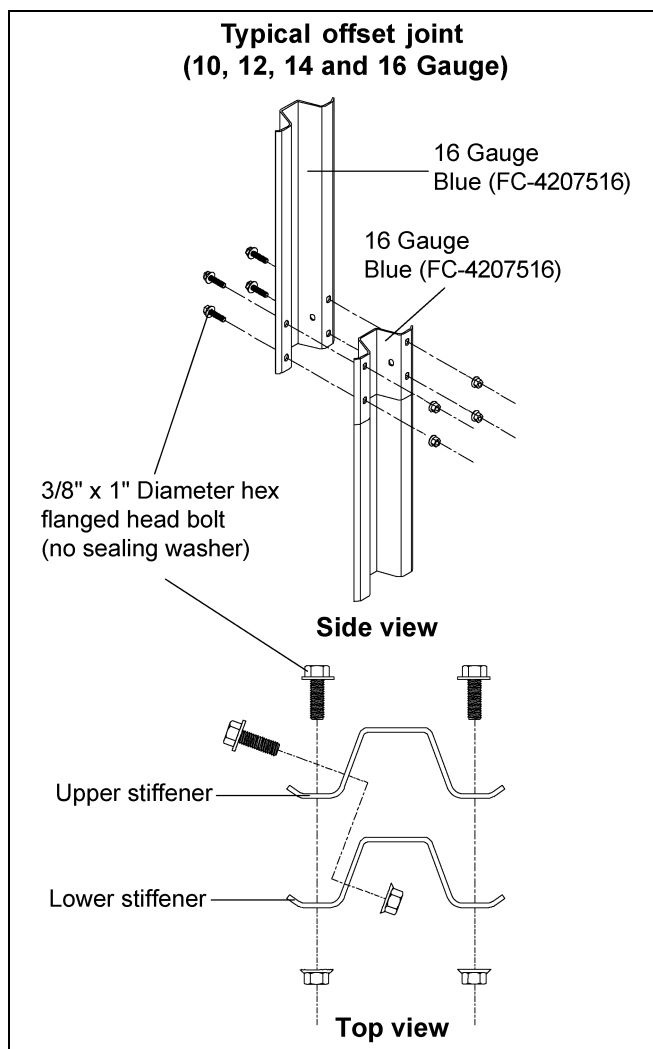

Figure 11D

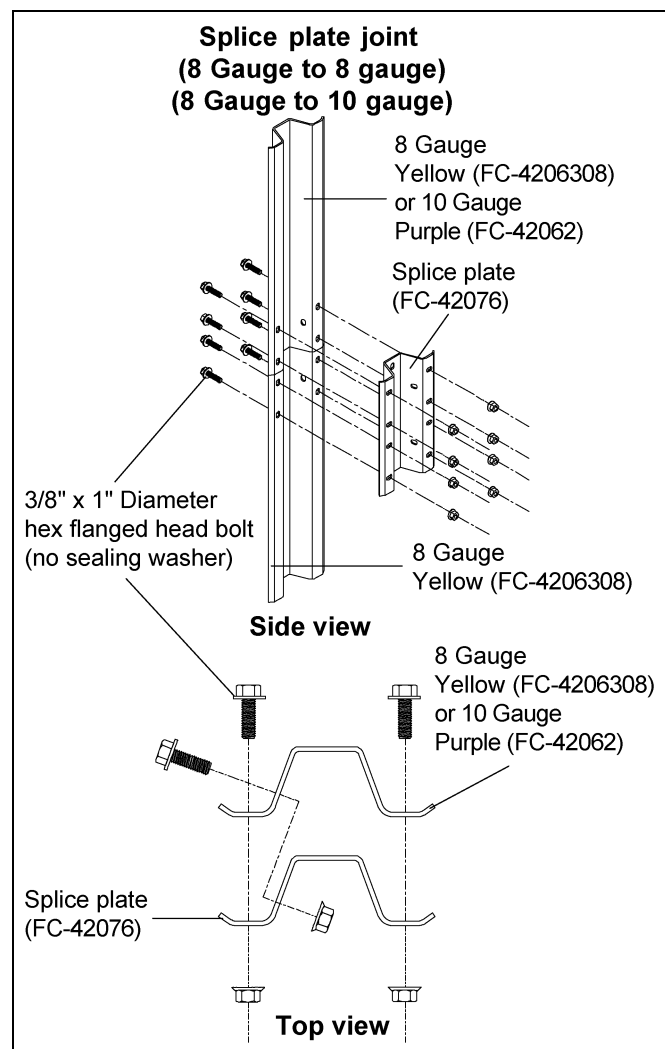
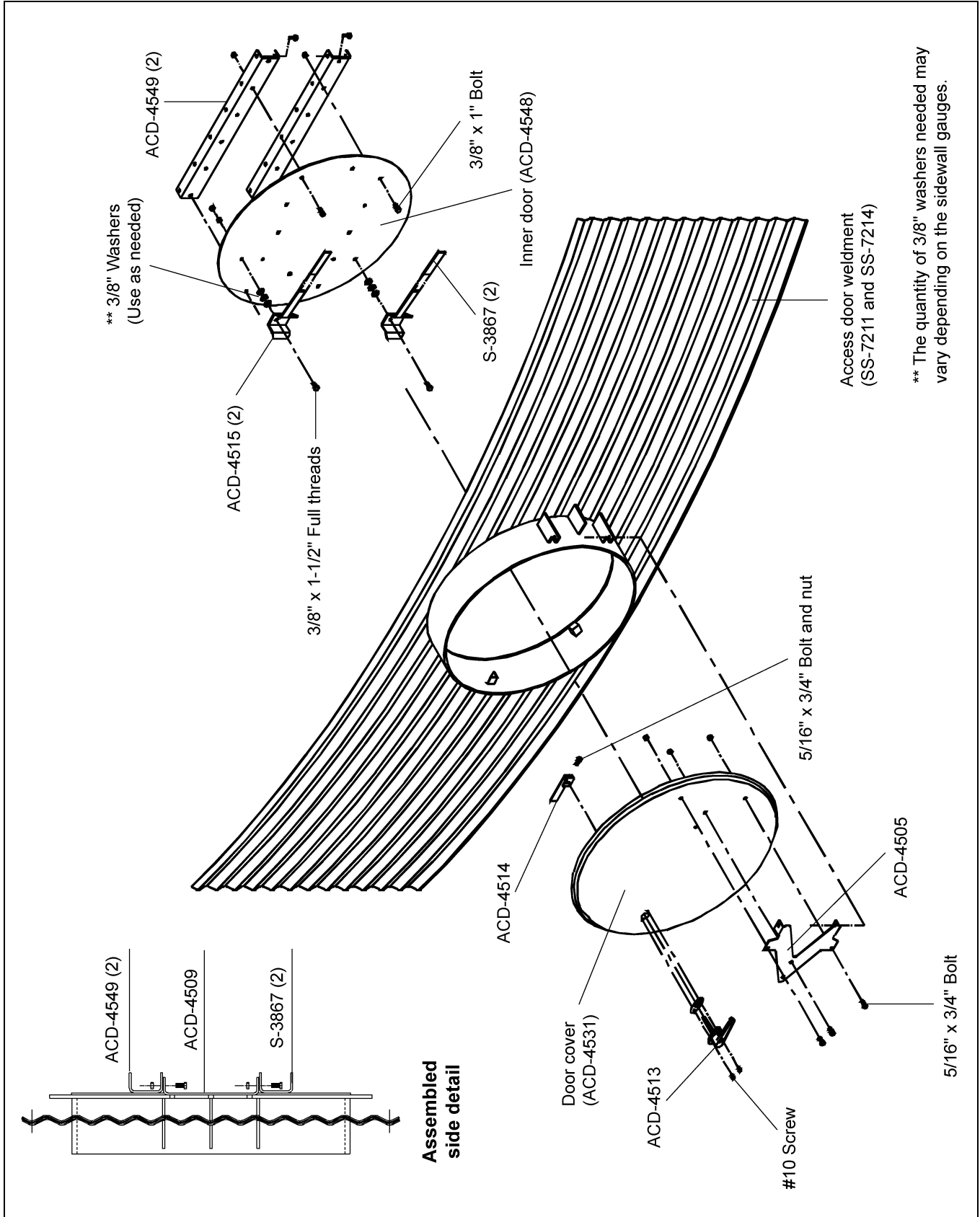

Figure 11E

Access Door Weldment Assembly Hardware Package (PLS-41985)



** The quantity of 3/8" washers needed may vary depending on the sidewall gauges.

Figure 12A

Aeration Package (Optional)

- Step 1:** Using reinforcing plate as a template, mark hole in hopper for cutting.
- Step 2:** Using a torch or saw, cut the hole in hopper sheets for tube.
- Step 3:** Remove enough bolts from hopper seam to allow reinforcing plate to set down on hopper panels.
- Step 4:** Install reinforcing plate on inside of hopper. Full weld and field drill holes and bolt in place. Drill holes through reinforcing plate where it overlaps holes in seam and re-install bolts.
- Step 5:** Install torpedo head at open end of tube and screw in place as shown *in Figure 13A*. (Screws not included.)
- Step 6:** Four (4) angles with corrugated pieces welded on them are supplied for each tube (two (2) per side). Bolt or weld each angle to the hopper sheet and screw or weld the corrugated material to the perforated tube (#14 x 1" self-drilling tek screws not provided).
- Step 7:** Full weld inside and outside around perimeter of aeration tube saddle 'tee'.
- Step 8:** Bolt or weld on angle ring for attachment of fan.
- Step 9:** Touch up any welded areas with a rust inhibitive type paint.
- NOTE:** When two (2) tubes are installed, second tube is to be installed 180° from first tube.

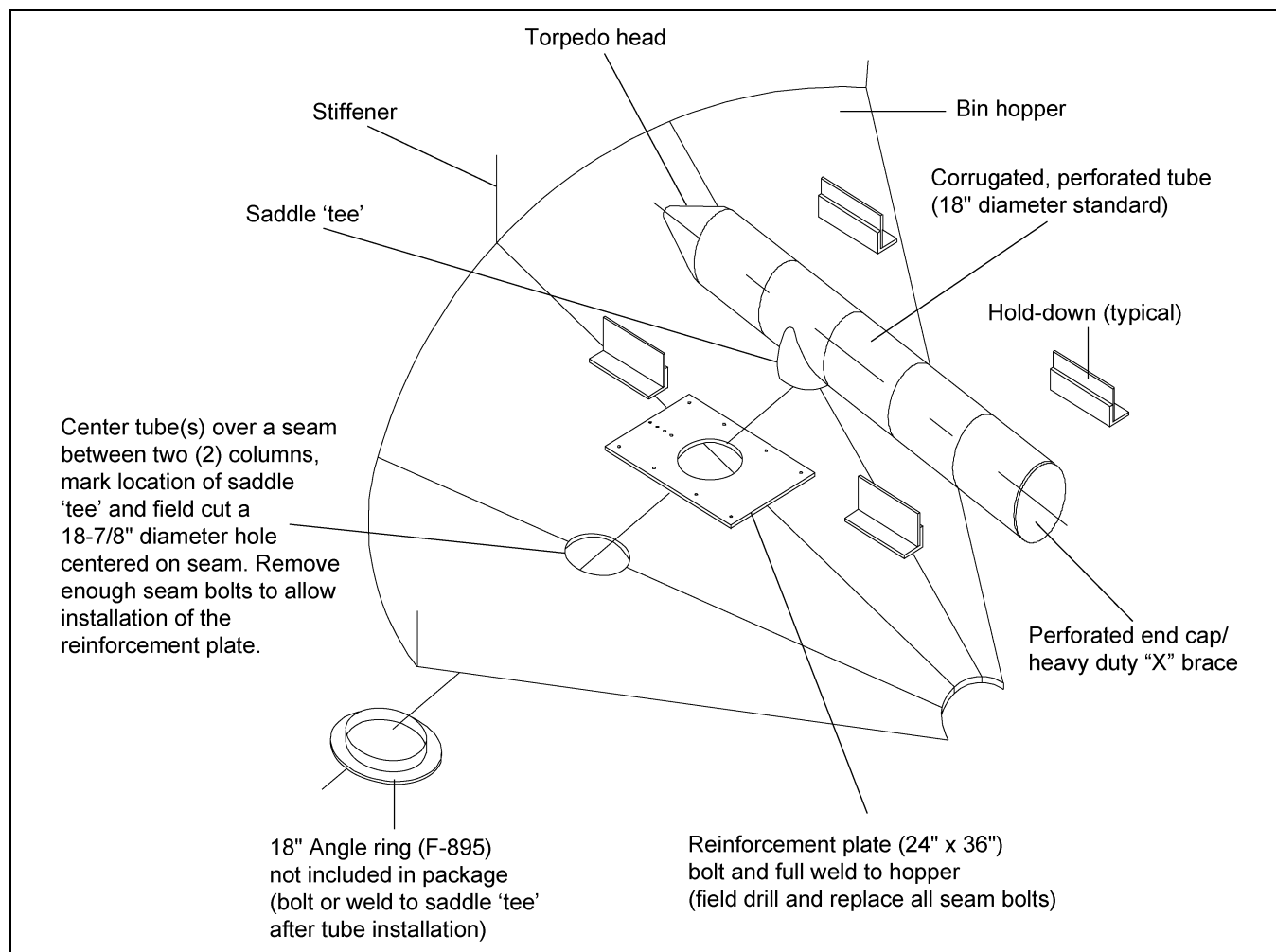

Figure 13A Typical Installation

Aeration Package (Optional) (Continued)

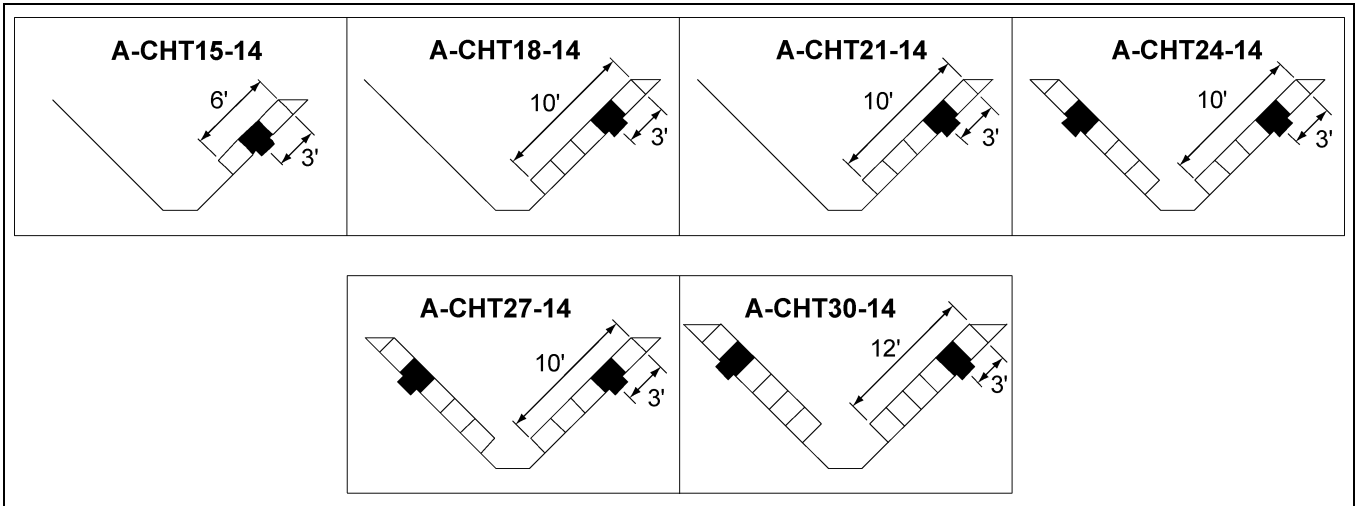

Figure 13B

System	Airflow Rating (CFM)
A-CHT15-14	1209
A-CHT18-14	2016
A-CHT21-14	2016
A-CHT24-14	4032
A-CHT27-14	4032
A-CHT30-14	4838

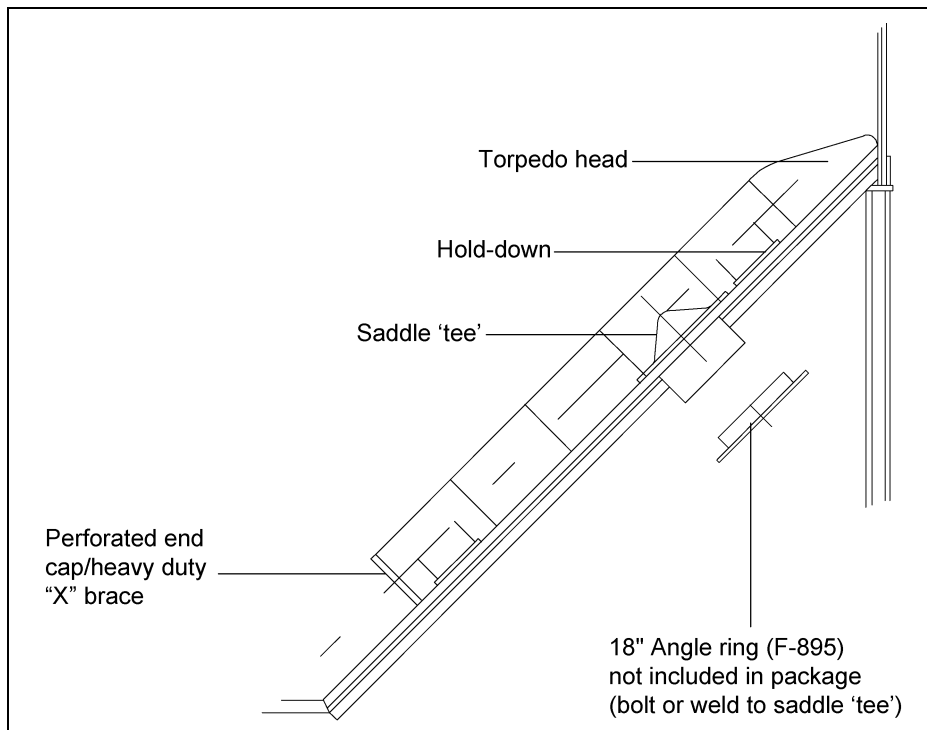

Figure 13C Typical Profile

Aeration Package (Optional) (Continued)

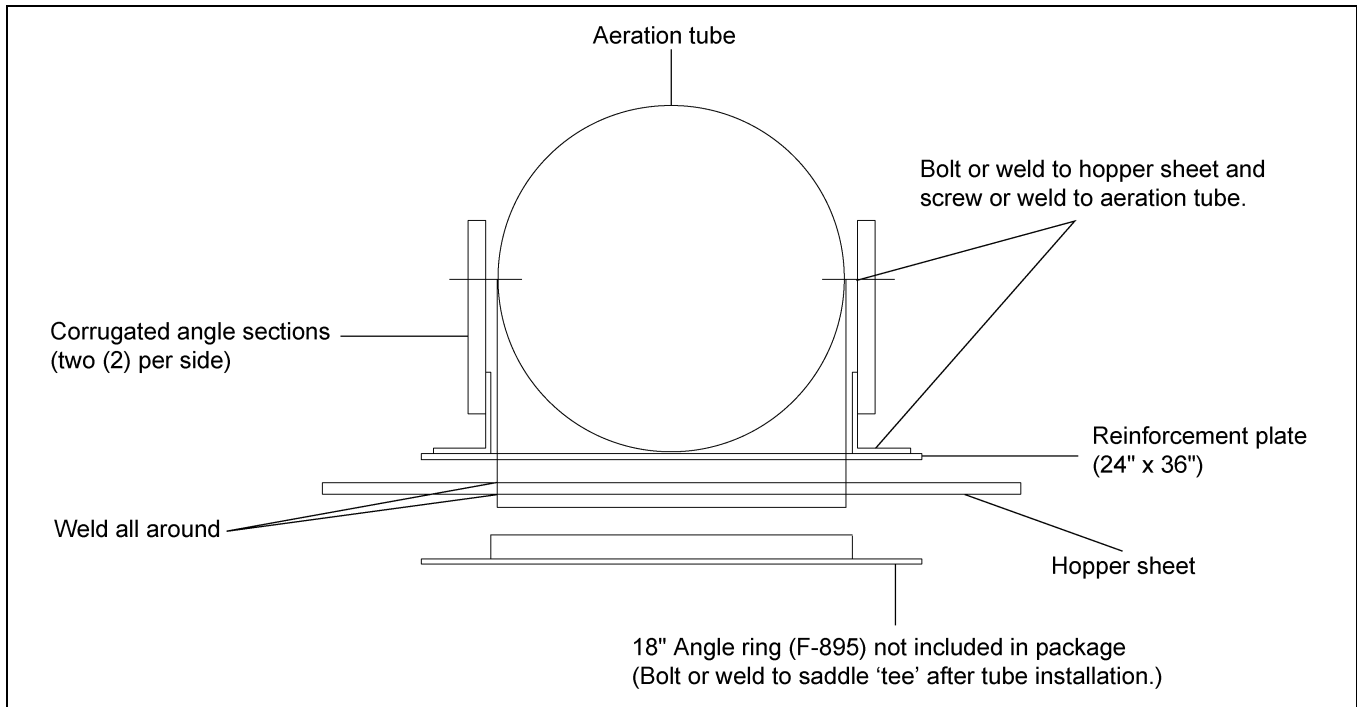

Figure 13D *Weld Detail*

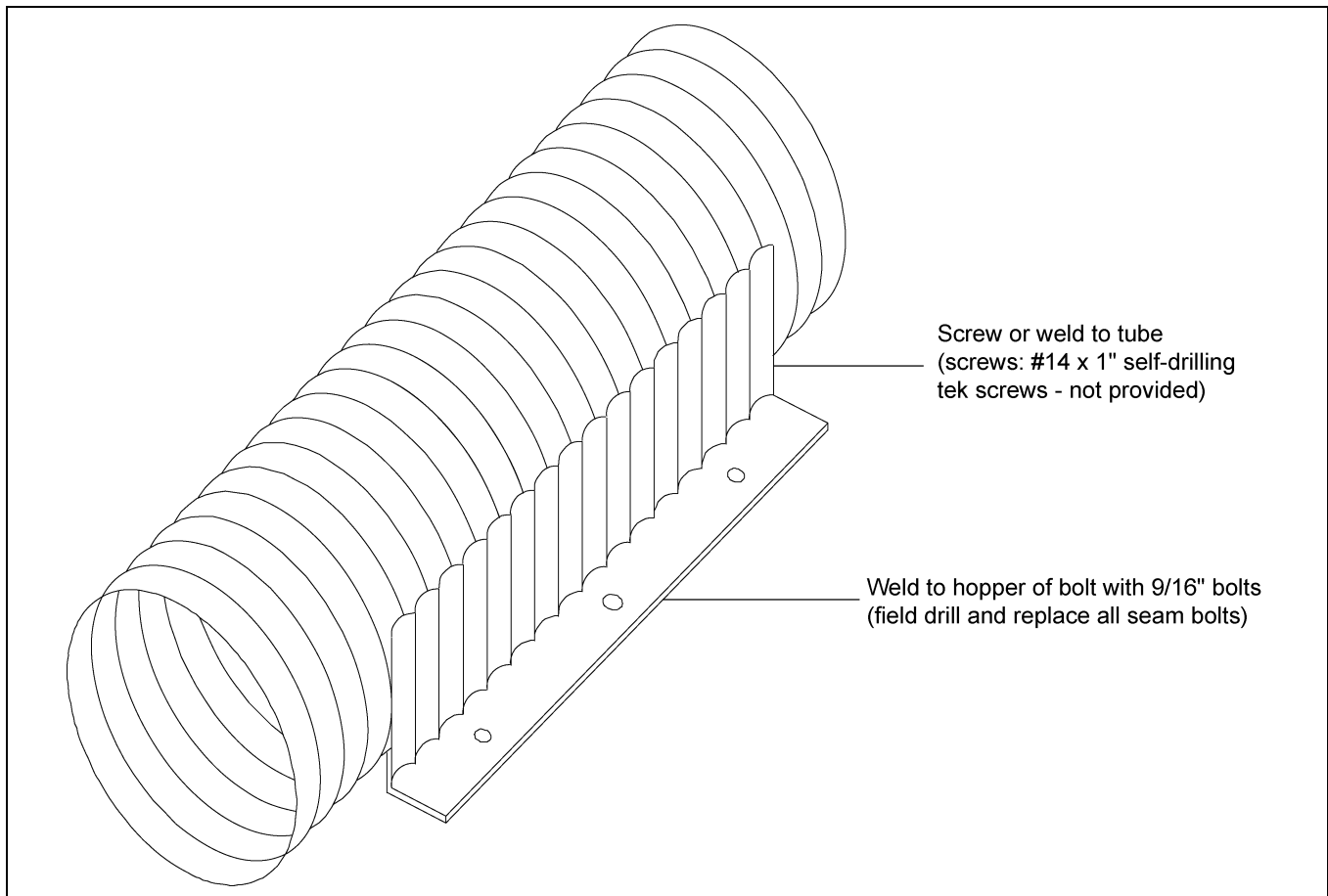

Figure 13E *Corrugated Angle Hold-Down Attachment Detail*

14. Flashing Instructions (Optional)

1. Attach flashing to the bin wall using the pre-punched holes at 8" above the horizontal seam.
2. Attach left side of the first piece of flashing to the sidewall using the connection as shown in [Figure 14A](#). Working clockwise, overlap the flashing at the right hand hole of each piece of flashing. **NOTE:** *If bolts are installed at flashing seam location they will need to be removed.*
3. At vertical seams attach flashing that is to span the vertical seams using both left and right holes. Drill flashing holes from the outside of the bin through the sidewall sheet holes. Remove drilled flashing and assemble vertical seam bolts and nuts. ([See Figure 14C on Page 49.](#)) Replace drilled flashing and attach according to [Figure 14B](#). Continue around the bin clockwise.

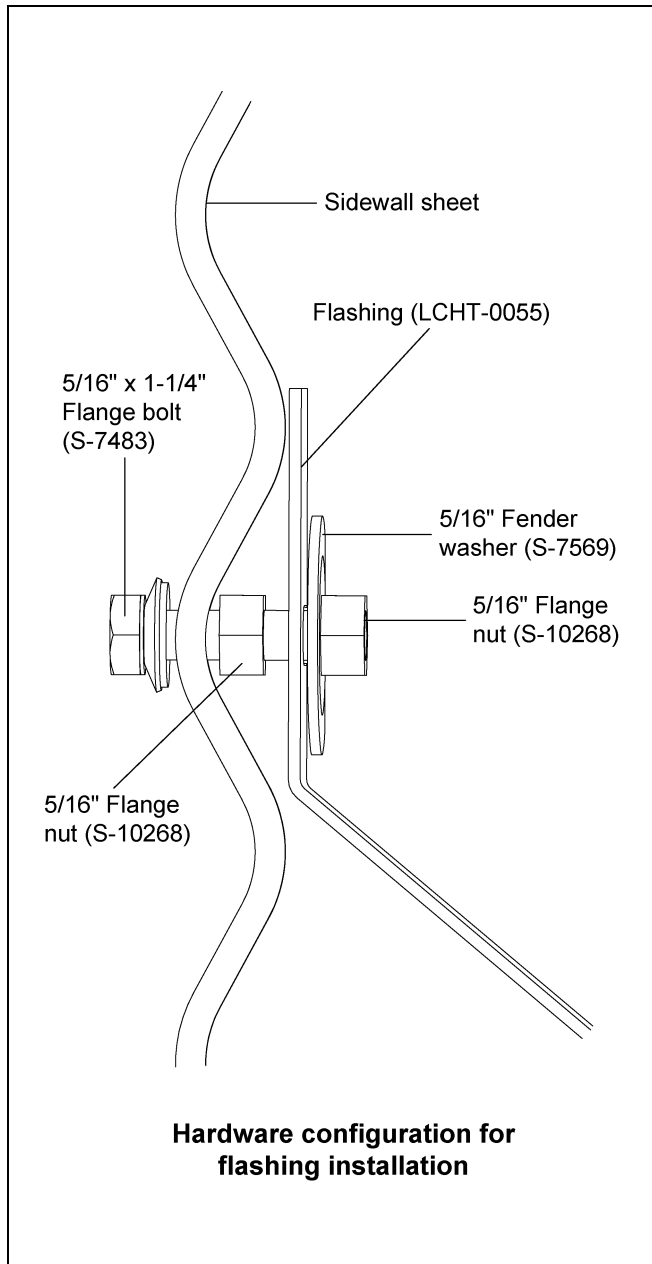

Figure 14A Flashing Hardware

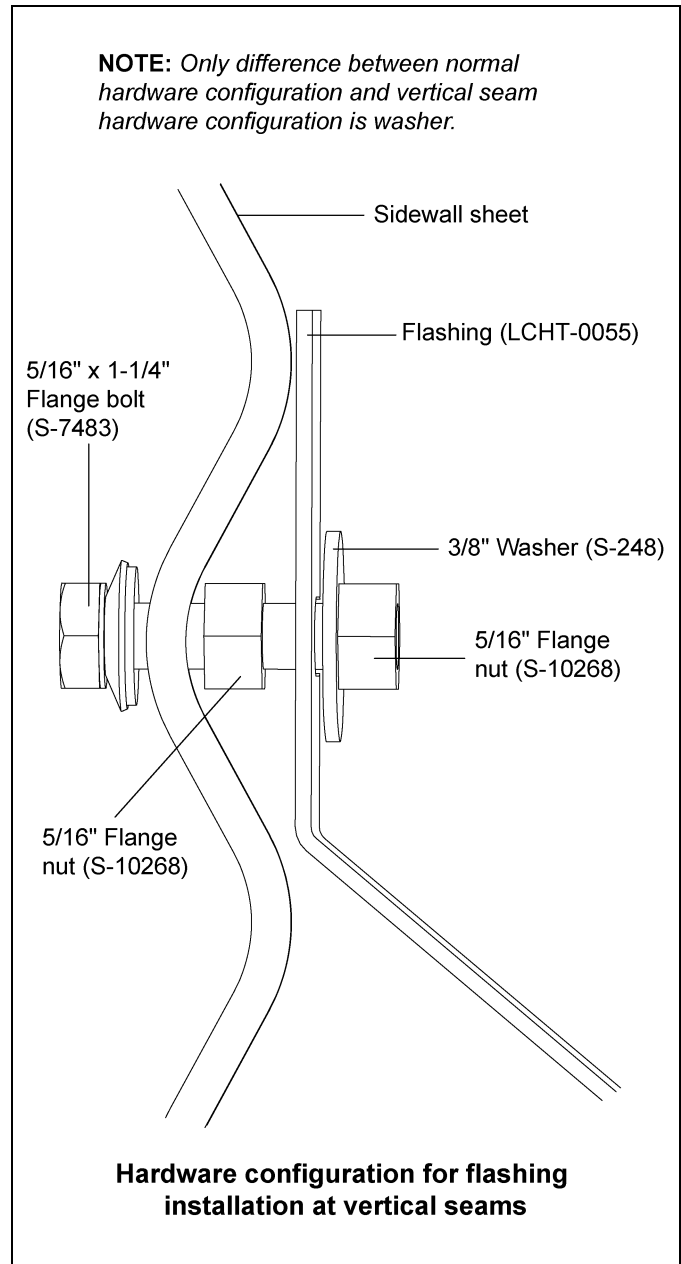

Figure 14B Vertical Seam Flashing Hardware

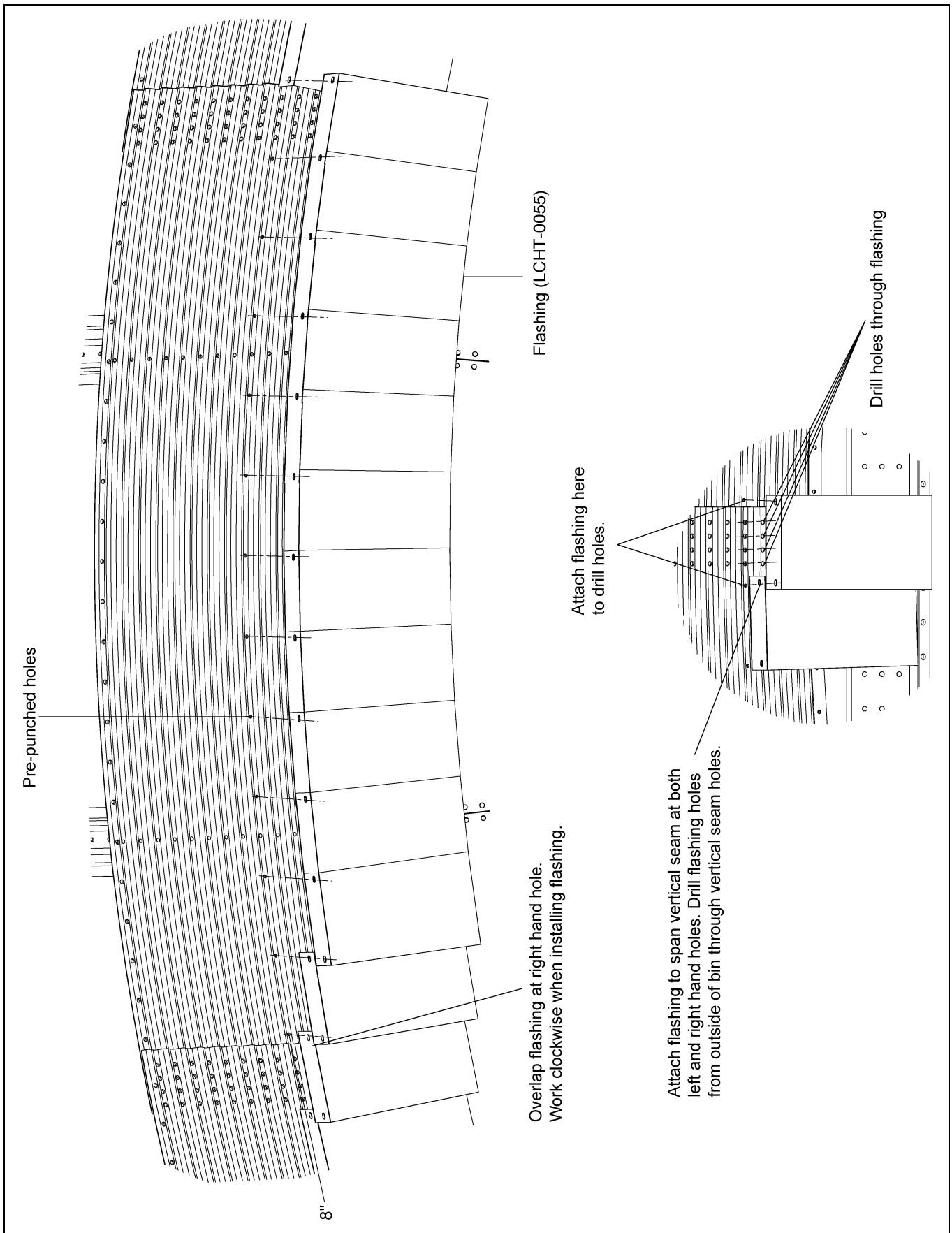

Figure 14C

Hopper Ladder Supports

Ladder Support Detail

The ladder must be secured to the hopper support columns with ladder standoff brackets using support channels and ladder brackets as shown *in Figure 15A*.

Tank Diameter	Hopper Slope	# of Support Channels	Hopper Ladder Brackets
18'	45	3	6
21'	45	4	8
24'	45	4	8

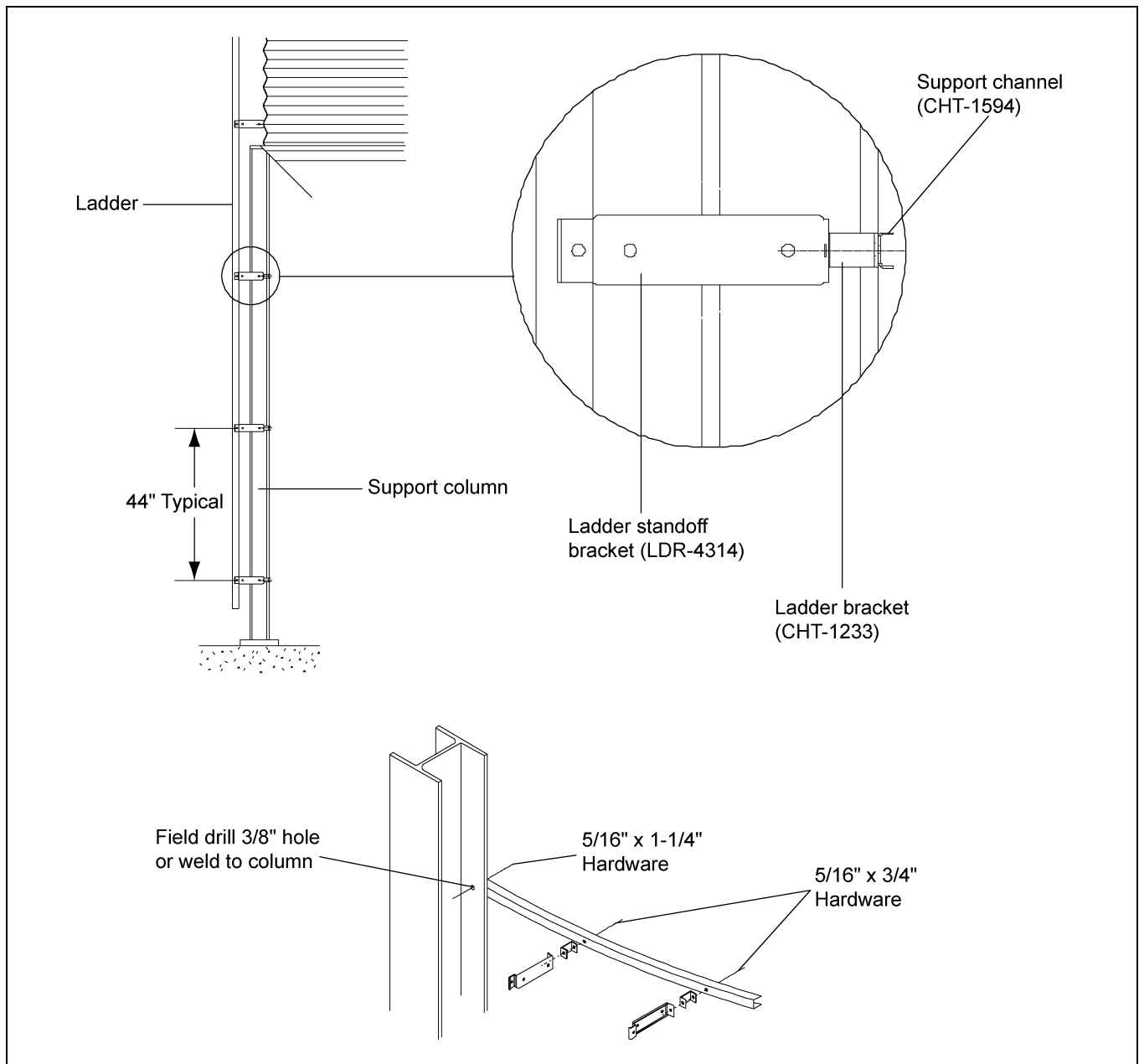

Figure 15A

Hoisting Recommendations

RECOMMENDATIONS FOR HOISTING COMPLETED TANK ONTO HOPPER BOTTOM STRUCTURE.

(ALL PARTS MENTIONED IN THIS SECTION ARE **NOT** FURNISHED.) A crane is normally used to lift the tank and place it on top of the substructure. Technique of hoisting of the complete tank on the hopper structure is in large part based on personal experience, equipment and manpower. The following recommendations are intended as a guideline only.

1. Before lifting the tank the following should be checked:
 - a. The columns and substructure should be checked for levelness and verified plumb and leveled if necessary.
 - b. Final ladder and safety cage and door locations should be determined and clearance at these locations verified.
 - c. Proper provisions should be made for safe working platforms around the top of the substructure.
2. Lifting technique are largely influenced by personal experience and equipment capacity however general recommendations as follow:
 - a. Lifting brackets should be attached to the stiffeners. At least one bracket per sidewall sheet should be used. These would typically be attached in the third ring from the bottom of the tank. Brackets should attach to a minimum of four (4) bolts through the stiffener. Attach cables to the lift brackets and to the crane hook, which has been lowered through the center ring opening. Cables should be sized to handle the entire weight of the bin. Make all lift cables of equal length before the bin is lifted. (See Figure 16A and Figure 16B.)

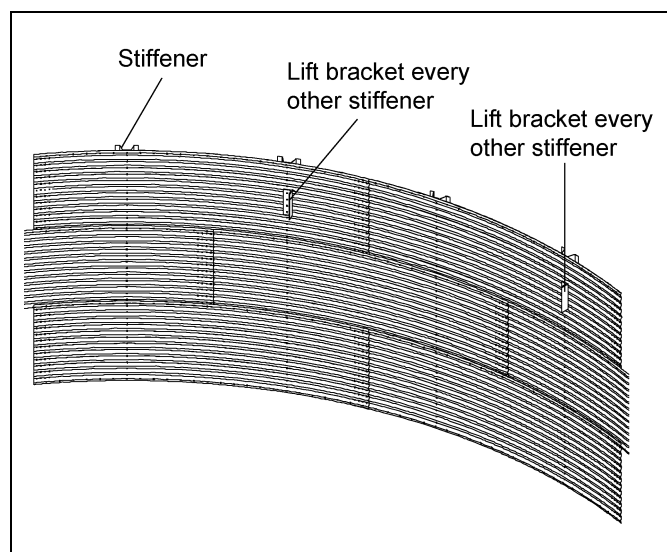

Figure 16A

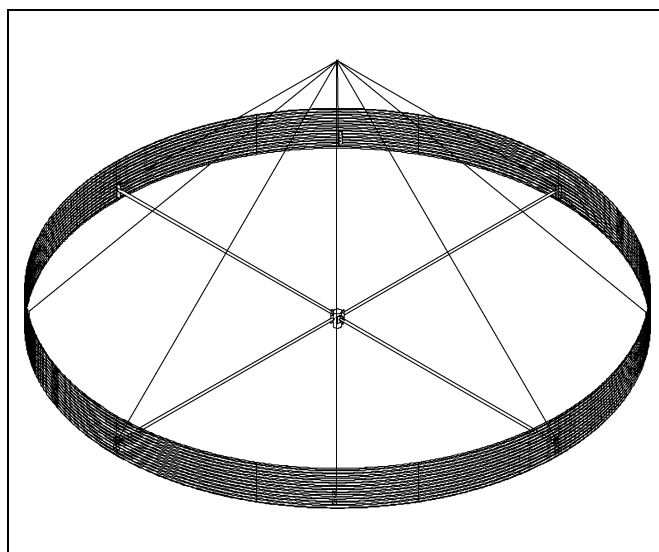

Figure 16B

Hoisting Recommendations (Continued)

- b. To prevent distortion of the assembled tank a “spider” or horizontal bracing is recommended. A suggested method of this is illustrated in the following details. This may be done by using a center “hub” and pipe. The center hub would typically be made of 6" schedule 40 pipe with 3" x 3" x 3/8" angle welded to it and the pipe bolting to the hub. The second smaller pipe would bolt to the lifting brackets attached to the stiffeners. (See Figure 16C.) Typical number of horizontal members that should be used are listed in the *below* chart.
- c. Use of temporary bracing across the peak collar may be needed to guide the cable. This should be made easily removable.

Recommended Minimum Number of Lift Brackets

Diameter	# of Brackets
18'	6
21'	7
24'	8

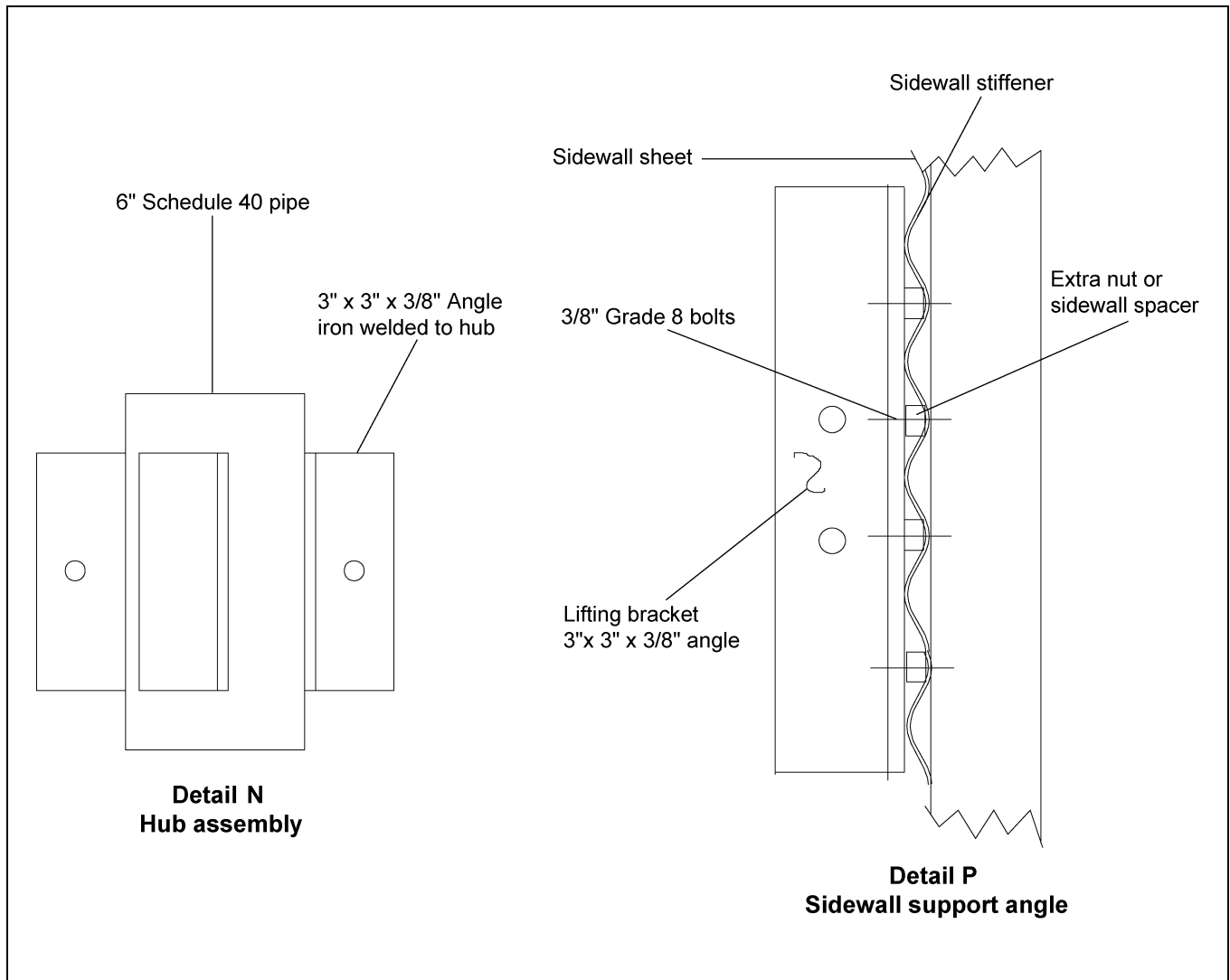

Figure 16C

Hoisting Recommendations (Continued)

- Before setting tank on hopper structure, make sure poly base sealer has been applied to bottom lip of tank base angle. Set tank on hopper compression ring and align the holes in stiffener base plates with the holes in the compression ring. Bolt stiffener base plate, compression ring and support column top plate with two (2) $5/8"$ x $2-3/4"$ hex head bolt per stiffener. Shim all stiffener base plates with a base angle shim plate. Column/stiffener shims can be used to shim stiffener base plates when needed. Align 4" bin hold-down with hole in center of compression element and attach with $5/8"$ x $1-1/2"$ hex head bolt. Field drill six (6) $3/8"$ diameter holes in tank sidewall to match pattern in bin hold-down. Bolt sidewall to hold with $5/16"$ diameter bin bolt. (See Figure 16D.)
- After tank is secured remove the spider or horizontal bracing and all hoisting attachments and cables.

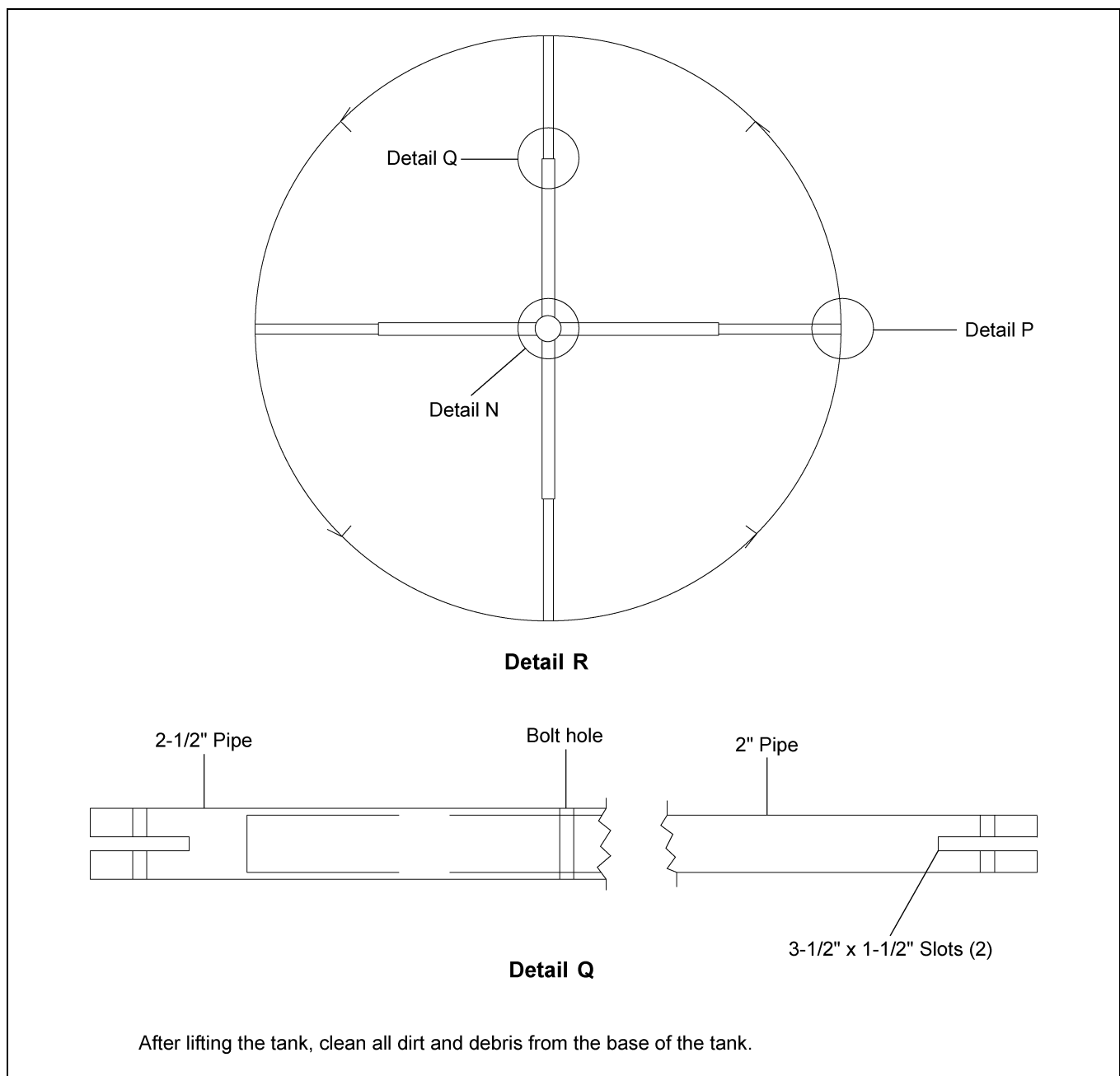

Figure 16D

17. Support Columns

Tank on Support Columns

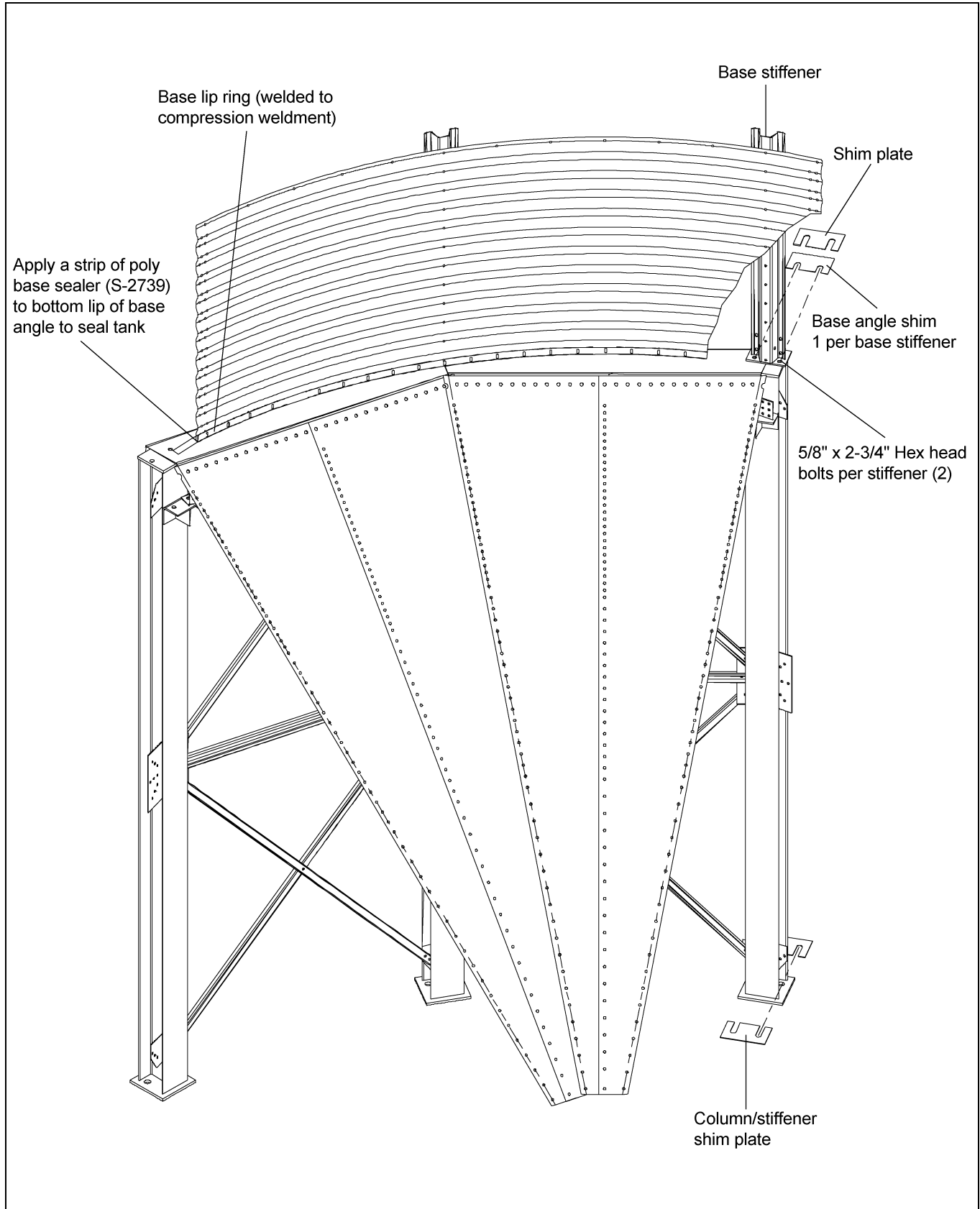

Figure 17A

GSI Group, LLC Limited Warranty

The GSI Group, LLC ("GSI") warrants products which it manufactures to be free of defects in materials and workmanship under normal usage and conditions for a period of 12 months after sale to the original end-user or if a foreign sale, 14 months from arrival at port of discharge, whichever is earlier. The end-user's sole remedy (and GSI's only obligation) is to repair or replace, at GSI's option and expense, products that in GSI's judgment, contain a material defect in materials or workmanship. Expenses incurred by or on behalf of the end-user without prior written authorization from the GSI Warranty Group shall be the sole responsibility of the end-user.

Warranty Extensions:

The Limited Warranty period is extended for the following products:

	Product	Warranty Period	
AP Fans and Flooring	Performer Series Direct Drive Fan Motor	3 Years	* Warranty prorated from list price: 0 to 3 years - no cost to end-user 3 to 5 years - end-user pays 25% 5 to 7 years - end-user pays 50% 7 to 10 years - end-user pays 75%
	All Fiberglass Housings	Lifetime	
	All Fiberglass Propellers	Lifetime	
AP and Cumberland	Flex-Flo/Pan Feeding System Motors	2 Years	** Warranty prorated from list price: 0 to 3 years - no cost to end-user 3 to 5 years - end-user pays 50%
Cumberland Feeding/Watering Systems	Feeder System Pan Assemblies	5 Years **	
	Feed Tubes (1-3/4" and 2.00")	10 Years *	
	Centerless Augers	10 Years *	
	Watering Nipples	10 Years *	
Grain Systems	Grain Bin Structural Design	5 Years	† Motors, burner components and moving parts not included. Portable dryer screens included. Tower dryer screens not included.
Grain Systems Farm Fans Zimmerman	Portable and Tower Dryers	2 Years	
	Portable and Tower Dryer Frames and Internal Infrastructure †	5 Years	

GSI further warrants that the portable and tower dryer frame and basket, excluding all auger and auger drive components, shall be free from defects in materials for a period of time beginning on the twelfth (12th) month from the date of purchase and continuing until the sixtieth (60th) month from the date of purchase (extended warranty period). During the extended warranty period, GSI will replace the frame or basket components that prove to be defective under normal conditions of use without charge, excluding the labor, transportation, and/or shipping costs incurred in the performance of this extended warranty.

Conditions and Limitations:

THERE ARE NO WARRANTIES THAT EXTEND BEYOND THE LIMITED WARRANTY DESCRIPTION SET FORTH ABOVE. SPECIFICALLY, GSI MAKES NO FURTHER WARRANTY OF ANY KIND, EXPRESS OR IMPLIED, INCLUDING, WITHOUT LIMITATION, WARRANTIES OF MERCHANTABILITY OR FITNESS FOR A PARTICULAR PURPOSE OR USE IN CONNECTION WITH: (I) PRODUCT MANUFACTURED OR SOLD BY GSI OR (II) ANY ADVICE, INSTRUCTION, RECOMMENDATION OR SUGGESTION PROVIDED BY AN AGENT, REPRESENTATIVE OR EMPLOYEE OF GSI REGARDING OR RELATED TO THE CONFIGURATION, INSTALLATION, LAYOUT, SUITABILITY FOR A PARTICULAR PURPOSE, OR DESIGN OF SUCH PRODUCTS.

GSI shall not be liable for any direct, indirect, incidental or consequential damages, including, without limitation, loss of anticipated profits or benefits. The sole and exclusive remedy is set forth in the Limited Warranty, which shall not exceed the amount paid for the product purchased. This warranty is not transferable and applies only to the original end-user. GSI shall have no obligation or responsibility for any representations or warranties made by or on behalf of any dealer, agent or distributor.

GSI assumes no responsibility for claims resulting from construction defects or unauthorized modifications to products which it manufactured. Modifications to products not specifically delineated in the manual accompanying the equipment at initial sale will void the Limited Warranty.

This Limited Warranty shall not extend to products or parts which have been damaged by negligent use, misuse, alteration, accident or which have been improperly/inadequately maintained. This Limited Warranty extends solely to products manufactured by GSI.

Prior to installation, the end-user has the responsibility to comply with federal, state and local codes which apply to the location and installation of products manufactured or sold by GSI.

This equipment shall be installed in accordance with the current installation codes and applicable regulations, which should be carefully followed in all cases. Authorities having jurisdiction should be consulted before installations are made.

G S I G R O U P



GSI Group
1004 E. Illinois St.
Assumption, IL 62510-0020
Phone: 1-217-226-4421
Fax: 1-217-226-4420
www.gsiag.com



GSI is a worldwide brand of AGCO Corporation.