

# 6"-8", & 8"-10" Commercial Bin Sweep Auger

Assembly & Operation Manual

PNEG-1048

Date: 05-01-2007

GSI GROUP



PNEG-1048



---

## **DO NOT STORE SWEEPS IN THE BIN!**

**Sweeps are NOT designed to remain in a bin during filling, storage, or bottom (gravity) unloading. A sweep left in a bin during these operations may be serverly damaged. The GSI Group, Inc. will not be responsible for such damages.**

**The following action may reduce damages to a sweep remaining in a bin: Lifting the sweep off the center pivot, positioning it parallel to the intermediate wells (*along side of - not on top of*) and fully supporting the sweep to the bin floor. However, even with this procedure, The GSI group, Inc. will not be responsible for any damges to the sweep.**

---

# SAFETY GUIDELINES

This manual contains information that is important for you, the owner/operator, to know and understand. This information relates to protecting **personal safety** and **preventing equipment problems**. It is the responsibility of the owner/operator to inform anyone operating or working in the area of this equipment of these safety guidelines. To help you recognize this information, we use the symbols that are defined below. Please read the manual and pay attention to these sections. Failure to read this manual and it's safety instructions is a misuse of the equipment and may lead to serious injury or death.



This is the safety alert symbol. It is used to alert you to potential personal injury hazards. Obey all safety messages that follow this symbol to avoid possible injury or death.



**DANGER** indicates an imminently hazardous situation which, if not avoided, will result in death or serious injury.



**WARNING** indicates a potentially hazardous situation which, if not avoided, could result in death or serious injury.



**CAUTION** indicates a potentially hazardous situation which, if not avoided, may result in minor or moderate injury.



**CAUTION** used without the safety alert symbol indicates a potentially hazardous situation which, if not avoided, may result in property damage.



**NOTE** indicates information about the equipment that you should pay special attention to.

---

# SAFETY GUIDELINES

## 1. General Safety Guidelines

- A. **DO NOT** make any alterations to the equipment. Such alterations may produce a very dangerous situation, where **SERIOUS INJURY** or **DEATH** may occur.
- B. This equipment shall be installed in accordance with any regulations or installation codes that are required by law. Authorities having jurisdiction should be consulted before installations are made.
- C. Untrained operators subject themselves and others to **SERIOUS INJURY** or **DEATH**. **NEVER** allow untrained personnel to operate this equipment.
- D. Keep children and other unqualified personnel out of the working area at **ALL** times.
- E. **NEVER** start equipment until **ALL** persons are clear of the work area.
- F. Be sure **ALL** operators are adequately rested and prepared to perform **ALL** functions of operating this equipment.
- G. Keep hair, loose clothing, and shoestrings away from rotating and moving parts. **NEVER** wear loose fitting clothing when working around augers.
- H. **NEVER** allow any person intoxicated or under the influence of alcohol or drugs to operate the equipment.
- I. **NEVER** allow anyone inside a bin, truck, or wagon which is being unloaded by an auger or conveyor. Flowing grain can trap and suffocate in seconds.
- J. Make sure someone is nearby who is aware of the proper shutdown sequence in the event of an accident or emergency.
- K. **NEVER** work alone.
- L. **ALWAYS** think before acting. **NEVER** act impulsively around the equipment.
- M. Make sure **ALL** equipment is locked in position before operating.
- N. Keep hands and feet away from the auger intake and other moving parts.
- O. **NEVER** attempt to assist machinery operation or to remove trash from equipment while in operation.
- P. Use ample overhead lighting after sunset to light the work area.
- Q. **ALWAYS** lockout **ALL** power to the equipment when finished unloading.
- R. Keep area around intake free of obstacles such as electrical cords, blocks, etc. that might trip workers.

## 2. Personal Protective Equipment

A. The proper personal protective equipment should be worn at **ALL** times by anyone in the work area.



B. **ALWAYS** wear safety glasses when in the work area.



C. The operator should **NEVER** wear jewelry.



D. Loose clothing should not be worn. Any clothing that becomes loosened should be tucked in tightly.

E. Loose or dangling shoe strings should be tucked in.



F. Long hair should be tied up and/or back.

---

### 3. Emergency Shutdown Sequence

- A. In an emergency, shutdown the power source.

### 4. Hazards

**A. Keep clear of all augers. DO NOT ENTER the bin!**

B. If you must enter this bin:

1. Shut off and lock out all power.
2. Use safety harness and safety line.
3. Station another person outside the bin.
4. Avoid the center of the bin.
5. Wear proper breathing equipment or respirator.

**C. Failure to heed these warnings will result in serious injury or death.**

**D. Be aware of Pinch Points. A *Pinch Point* is a narrow area between two surfaces that is likely to trap or catch objects and so is a potential safety hazard.**

**E. Components of this equipment have sharp edges which can scrape and/or cut an operator.**

**F. A moving auger can sever appendages possibly resulting in death.**

### 5. Shields and Guards

- A. **ALWAYS** keep **ALL** shields and guards in place during operation.

**We will replace any missing shields or guards free of charge!**

*See page 9 for more information on our Safety First program.*

*Safety* **1<sup>st</sup>**

### 6. Operator Qualifications

- A. The User/Operator must be competent and experienced to operate auger equipment. Anyone who works with or around augers must have good common sense in order to be qualified. These persons must also know and meet all other qualifications, such as:
  1. Any person who has not read and/or does not understand all operation and safety procedures is not qualified to operate any auger systems.
  2. Certain regulations apply to personnel operating power machinery. Personnel under the age of 18 years may not operate power machinery, including augers. It is your responsibility, as owner and/or supervisor, to know what these regulations are in your area or situation.
  3. Unqualified or incompetent persons are to remain out of the work area.
  4. O.S.H.A. (Occupational Safety & Health Administration) regulations state:  
"At the time of initial assignment and at least annually thereafter, the employer shall instruct every employee in the safe operation and servicing of all equipment with which the employee is, or will be involved." (Federal Occupational Safety & Health Standards for Agriculture. Subpart D, Section 19287.57 (a) (6).

---

## 6. Operator Qualifications (*cont.*)

- B. As a requirement of OSHA, it is necessary for the employer to train the employee in the safe operating and safety procedures for this auger. We included this sign-off sheet for your convenience and personal record keeping. All unqualified persons are to stay out of the work area at all times. It is strongly recommended that another qualified person who knows the shutdown procedure is in the area in the event of an emergency. A person who has not read this manual and understands all operating and safety instructions is not qualified to operate the machine.

Date	Employer's Signature	Employee Signature
1		
2		
3		
4		
5		
6		
7		
8		
9		
10		
11		
12		
13		
14		
15		
16		
17		
18		
19		
20		
21		
22		



---

# *Safety* 1<sup>st</sup>

Our equipment is built to provide many years of dependable service to our customers through durable craftsmanship.

One of the most important aspects of our engineering is **SAFETY** 1<sup>st</sup> design throughout all product lines. At our company - safety is NO ACCIDENT!

That is why we have implemented a **SAFETY** 1<sup>st</sup> program. Should you ever need guards, shields, safety decals or owner/operator manuals, simply contact us or your local dealer, and we will supply you with them **FREE OF CHARGE!**

While it is our main goal for our company to be the world leader in auger manufacturing, it is always our first priority to keep our customers safe.

If you need any of the above listed safety items or have any safety questions, please contact the manufacturer or your local dealer.

*We replace missing guards and shields*  
**FREE OF CHARGE!**

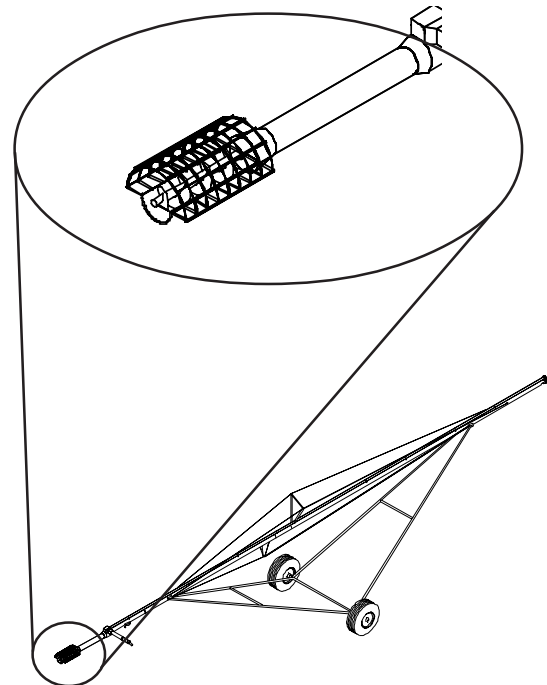

---

**Personnel operating or working around this equipment should read this manual. This manual must be delivered with equipment to its owner. Failure to read this manual and its safety instructions is a misuse of the equipment. Any misuse of the equipment may void the warranty.**

## **1. General Information**

A. We reserve the right to improve our product whenever possible and practical to do so. We reserve the right to change, improve, and modify products at any time without obligation to make changes, improvements, and modifications on equipment sold previously.

B. The Commercial Bin Sweeps have been designed and manufactured to give years of dependable service. The care and maintenance of this machine will affect the satisfaction and service obtained. By observing the instructions and suggestions we have recommended, the owner should receive competent service for many years. If additional information or assistance should be required, please contact the factory or your local dealer.

### **C. Receiving Merchandise and Filing Claims**

1. When receiving merchandise, it is important to check both the quantity of parts and their descriptions with the packing list enclosed within each package. All claims for freight damage or shortage must be made by the consignee within ten (10) days from the date of the occurrence of freight damage. The consignee should accept the shipment after noting the damage or loss.

---

## TABLE OF CONTENTS

Safety .....	4-8
<b>SAFETY 1<sup>st</sup></b> .....	9
General Information .....	10
Table of Contents .....	11
Decals .....	12
Assembly .....	13-17
Installation .....	18-20
Final Cleanout .....	21
Power Source .....	22-23
Troubleshooting .....	24
Parts List .....	25-30
Warranty .....	Inside Back Cover

**Personnel operating or working around this equipment should read this manual. This manual must be delivered with equipment to its owner. Failure to read this manual and its safety instructions is a misuse of the equipment. Any misuse of the equipment may void the warranty.**

# SAFETY DECALS

Check components shown below to insure that the safety decals are in place and in good condition. If a decal cannot be easily read for any reason or has been painted over, replace it immediately. Contact your dealer or the manufacturer to order a replacement decal free of charge.

DANGER Sign No. DC-1395 was supplied with your bin unloading equipment. This safety sign should be applied to the side of the bin near the bin opening, so it will be viewed by people entering into the bin storage building. Do not cover any safety signs or any other signs that are already there.

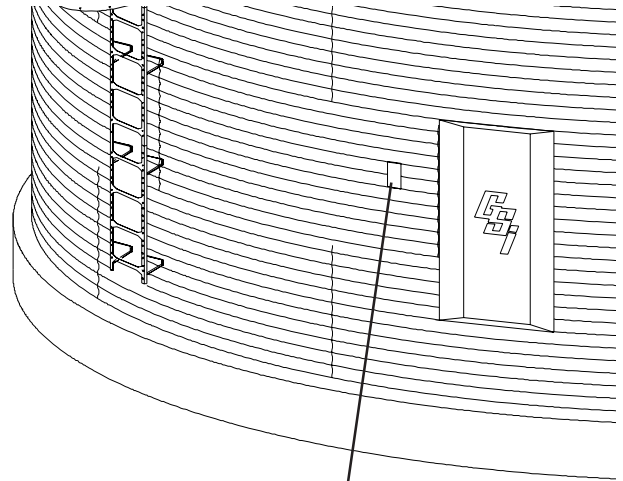

**NOTE** Please remember, safety signs provide important safety information for people working near bin unloading equipment that is in operation.

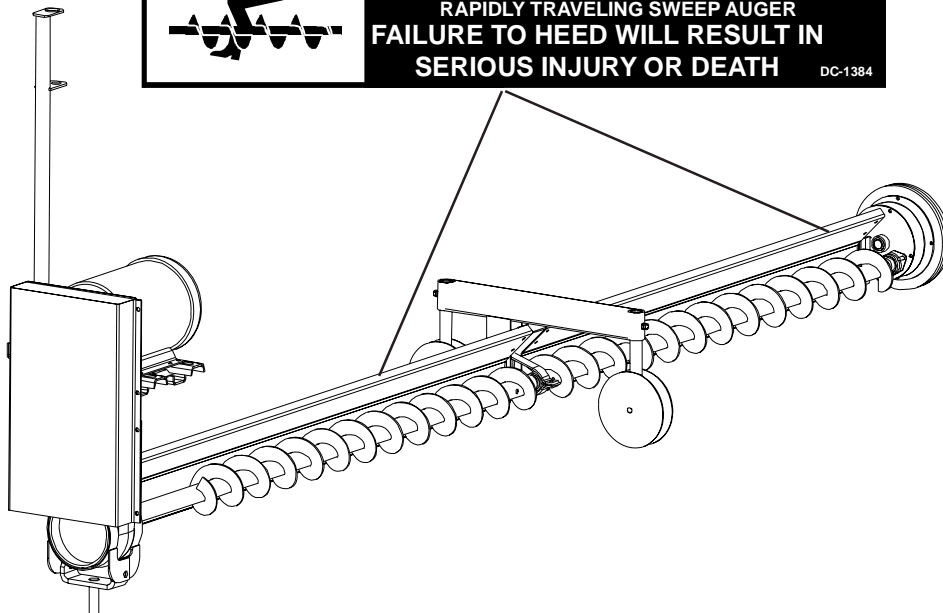

**WARNING** If the Safety Sign cannot be easily read for any reason or has been painted over, replace it immediately. Additional Safety Signs may be obtained *free of charge* from your dealer, distributor, or ordered from the factory.

# 1. ASSEMBLY INSTRUCTIONS

## A. Motor Mount Assembly Instructions

1. First, fill the chain reducer drive with oil by removing the vented fill plug and pouring 48 oz. of oil into drive. Oil level can be checked by removing the check plug. Oil should not be over the check plug. (See Fig. 1)

**CAUTION**

Oil must be added before assembly. The chain reducer is shipped without oil.

Do NOT add more oil than recommended additional oil may damage the seals or be forced out through the vented fill plug.

For lubrication in normal operating temperature between 40° F to 120° F, we recommend the use of non foaming, multi purpose gear oil, SAE 90 weight. For temperatures below 40° F, use a SAE 80 weight oil. Use grade commercially available for automotive differentials. Extra pressure additives may be of value in severe applications.

2. Assemble the belt guard & mount frame, enclosed chain drive, sweep shield & drive frame and center pivot weldment together as shown below in Fig. 2.

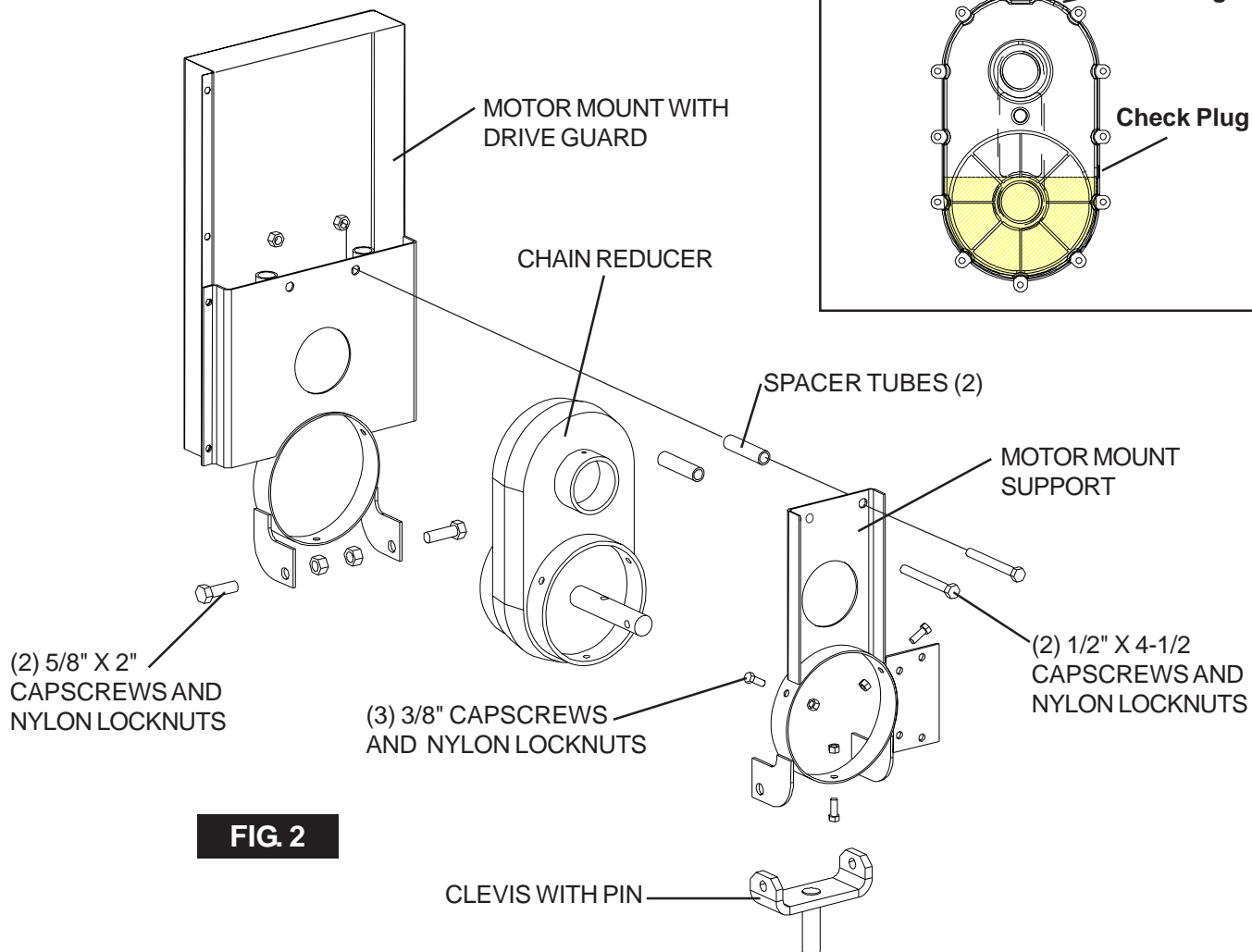
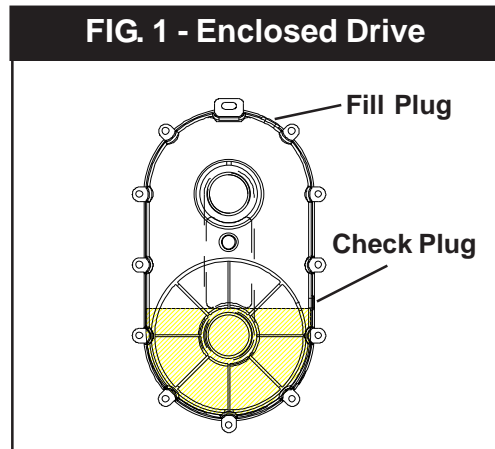

- Slide motor mount rods through the belt guard back plate and into the tubes on the motor mount frame. Attach the top and bottom straps to the motor mount rods as shown in Fig. 3.
- Install the electric motor on the motor mount straps.
- Install the drive sheave onto the motor shaft using the 1/4" square key and tighten. (See pages 22-23 for motor and pulley sizes.)
- Install the belts and tighten them by adjusting the motor with the 7/8" nuts on the motor mount rods. Bolt the shield door closed with two 5/16" x 3/4" capscrews and nylon locknuts.

**FIG. 3**

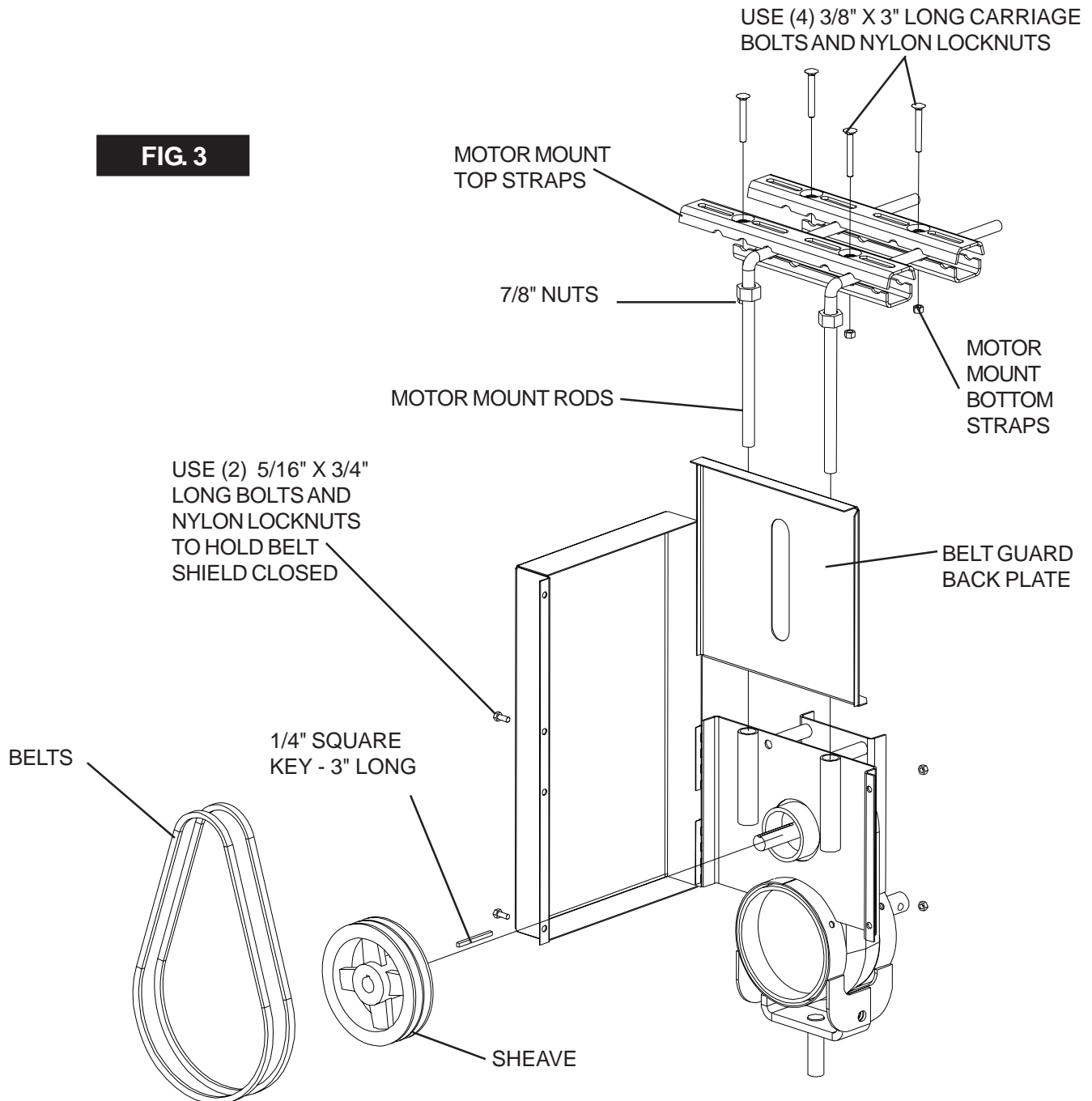

B. Electric Cord Support Stand Assembly

1. Install support stand onto the motor mount straps using two 7/16" x 1-1/4" HHCS Bolts four 7/16" flat washers and 7/16" nylock nuts. (See Fig. 4)
2. Route the electrical cord from the motor through the support stand clamps. Leave a small loop of cord between clamps and motor. (See Fig 4)

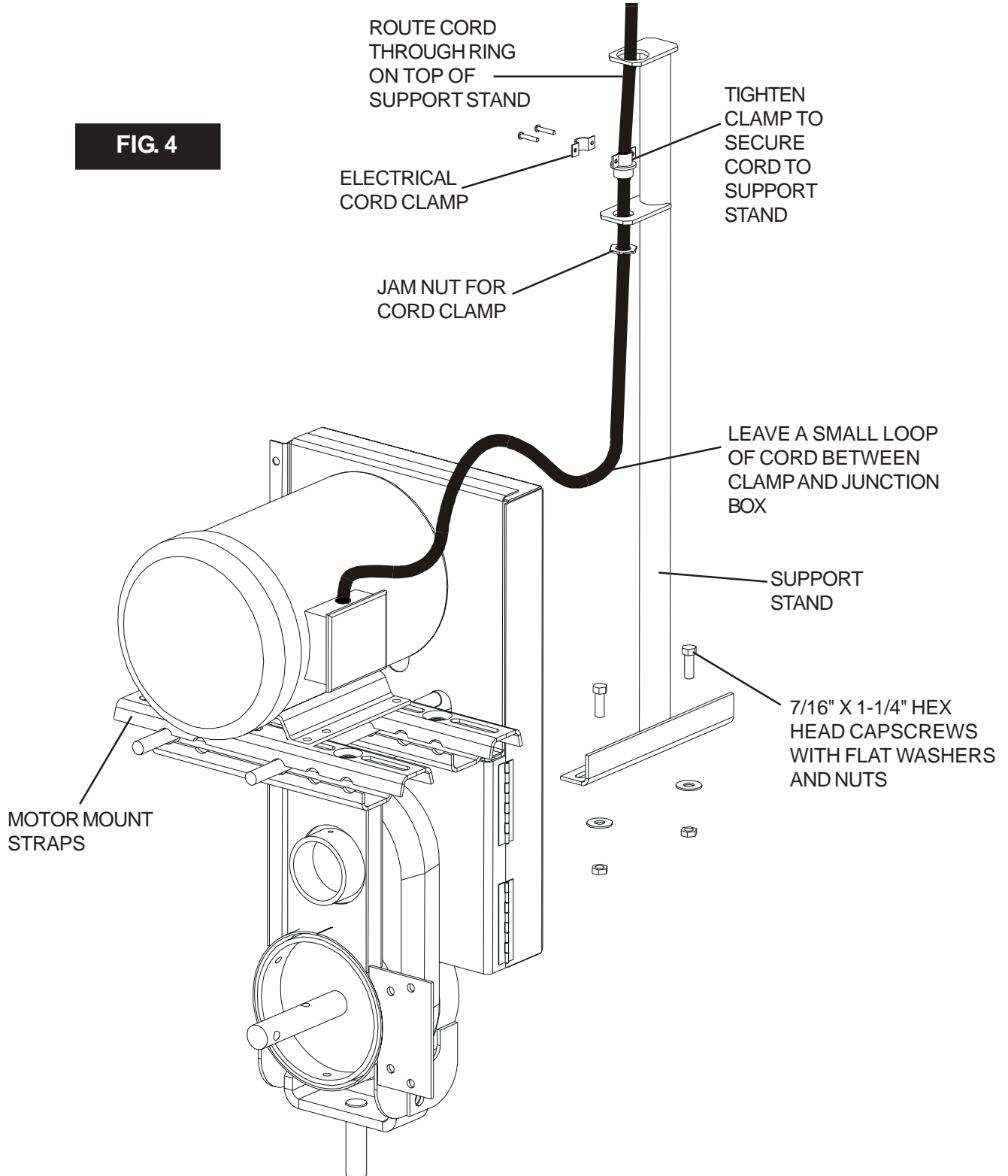

C. Assembling Sweep Flight & Back Shield Assembly

1. The number and lengths of sweep flighting and back shield sections will vary depending on the bin size. See chart below for the flight and shield sections for your size bin.
2. The sweep flight with a cut back must connect to the drive assembly. The remaining sections should be assembled in the order shown in the chart below.

The following instructions are for assembling a complete commercial sweep. If you have a large bin it is recommended to use only part of the sweep auger when starting to sweep unload a bin. Refer to page 19, section D in this manual for more information.

<b>Sweep Flight and Back Shield Sections</b>						
<b>6" Catalog Number</b>	<b>8" Catalog Number</b>	<b>Bin Diameter</b>	<b>1st Section w/ cutback attached to Drive Unit</b>	<b>2nd Section from Drive Unit</b>	<b>3rd Section from Drive Unit</b>	<b>4th Section from Drive Unit</b>
GCS82400	GCS10240	24'	6'- 6 1/2"	3'- 9 1/2"		
GCS82700	GCS10270	27'	6'- 6 1/2"	5'- 3 1/2"		
GCS83000	GCS10300	30'	9'- 6 1/2"	3'- 9 1/2"		
GCS83300	GCS10330	33'	8'- 1/2"	6'- 9 1/2"		
GCS83400	GCS10340	34'	6'- 6 1/2"	8'- 10"		
GCS83600	GCS10360	36'	6'- 6 1/2"	9'- 9 1/2"		
GCS83700	GCS10370	37'	8'- 1/2"	8'- 10"		
GCS83900	GCS10390	39'	8'- 1/2"	9'- 9 1/2"		
GCS84000	GCS10400	40'	9'- 6 1/2"	8'- 10"		
GCS84200	GCS10420	42'	9'- 6 1/2"	9'- 9 1/2"		
GCS84800	GCS10480	48'	6'- 6 1/2"	5'- 10"	9'- 9 1/2"	
GCS84900	GCS10490	49'	6'- 6 1/2"	9'- 3 1/2"	6'- 9 1/2"	
GCS85400	GCS10540	54'	9'- 6 1/2"	5'- 10"	9'- 9 1/2"	
GCS85500	GCS10550	55'	8'- 1/2"	9'- 3 1/2"	8'- 3 1/2"	
GCS86000	GCS10600	60'	9'- 6 1/2"	8'- 10"	9'- 9 1/2"	
	GCS10630	63'	9' - 6 1/2"	5' - 3 1/2"	5' 10"	8' 10"
	GCS10680	68'	9' - 6 1/2"	5' 10"	6' - 9-1/2"	9' - 9 1/2"
	GCS10690	69'	8' - 1/2"	5' - 3 1/2"	9' - 3 1/2"	9' - 9 1/2"
	GCS10720	72'	9' - 6 1/2"	5' 10"	8' - 10"	9' - 9 1/2"
	GCS10750	75'	8' - 1/2"	8' 10"	8' - 10"	9' - 9 1/2"
	GCS10780	78'	9' - 6 1/2"	9' - 9 1/2"	8' - 10"	8' - 10"
	GCS10800	80'	9' - 6 1/2"	9' - 9 1/2"	9' - 9 1/2"	8' - 10"
GCS10820	82'	9' - 6 1/2"	9' - 9 1/2"	9' - 9 1/2"	9' - 9 1/2"	



3. Bolt the sweep flight with the cutback to the reducer output shaft of the drive assembly using two (2) 7/16" x 2-1/2" HHCS Bolts & locknut. Attach the back shield to the drive frame using two (2) 3/8" x 1-1/4" carriage bolt, flat washers and nylon lock nuts. (See Fig. 5)
4. Connect the sweep flights together with the connecting stub shaft using four (4) 7/16" x 2-1/2" HHCS Bolts and locknuts. Be sure to place connecting stub shaft through the bearing bracket before attaching the flight together. (See Fig. 5)
5. Attach the back shields to the bearing bracket using two 3/8" x 3" carriage bolts with flat washers and lock nuts. Connect the splice plate to the shields with four 5/16" x 3/4" HHCS bolts and locknuts. For bins 48 ft. or larger in diameter, install the sweep carrier at a bearing location in the center or outward of center of sweep length. (See Fig. 5)
6. Connect the reduction sweep wheel to the back shield using 3/8" x 1-3/4" HHCS Bolt, 3/8" flat washer, and locknuts. (See Fig. 5 & 6) Orient the bushing with the bolt hole nearest the wheel. Select one of the two holes in the flight and wheel shaft to line up with the holes in the bushing. Connect them all together using a 3/8" x 2-1/2" HHCS Bolt with locknut for 6" and a 3/8" x 3" HHCS Bolt with locknut for 8". Use spacers as necessary to connect the wheel angle bracket to the back shield.

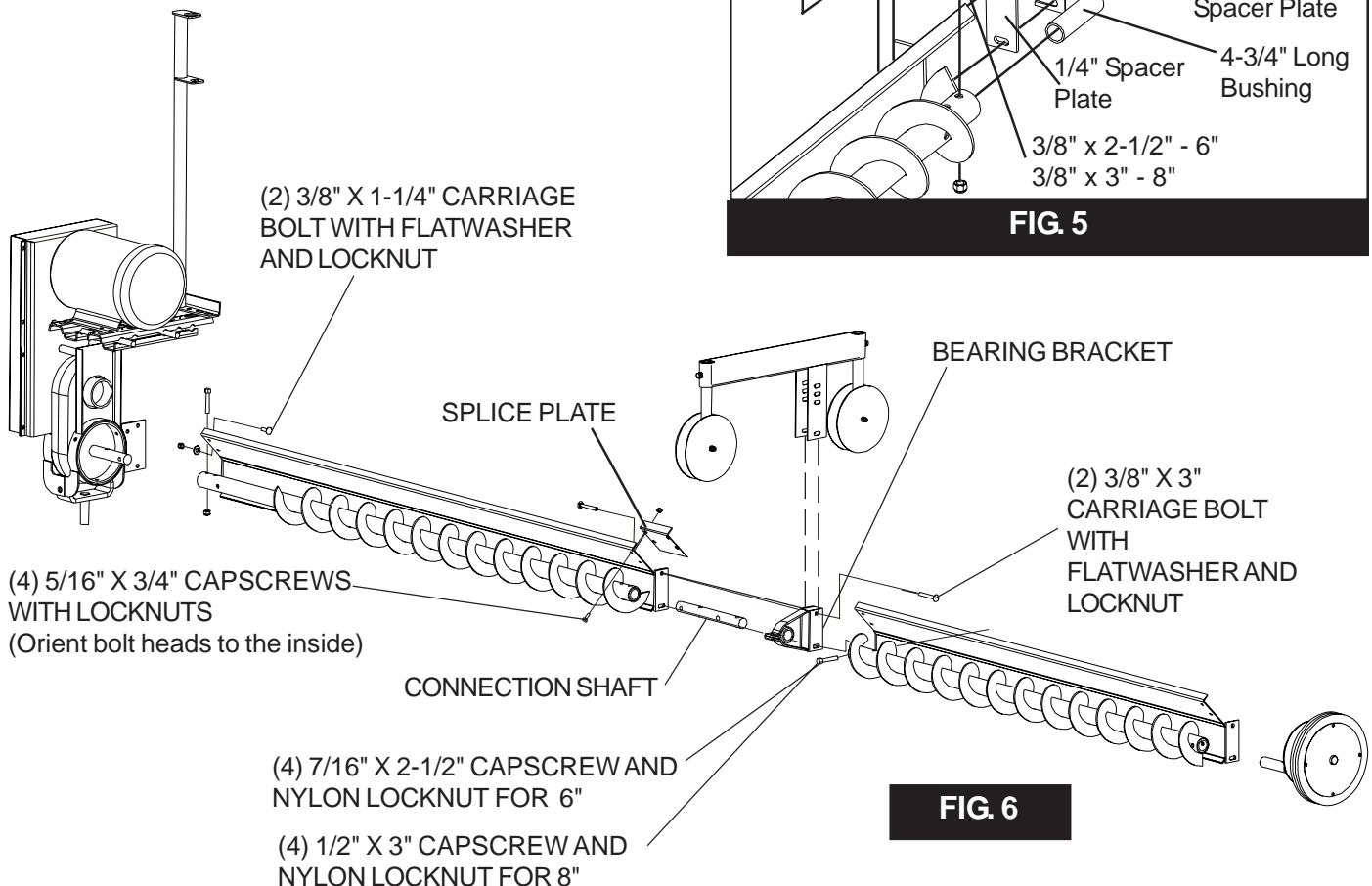
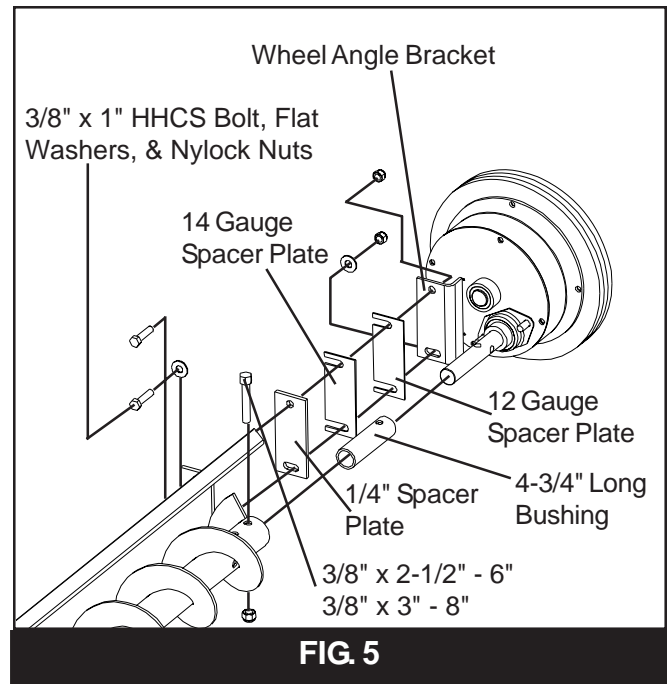

## 2. INSTALLATION PROCEDURES

- A. Shut down and lock out the unloading unit before entering the bin.

If the bin is not equipped with intermediate wells, the Commercial Sweep Auger may be placed in the bin after all the grain has been removed that will gravity flow through the center well.

The grain remaining should appear as in Figure 9. **DO NOT** enter a bin if the grain has bridged or flowed abnormally out of the bin as shown in Figure 7 or Figure 8. Suffocation can occur if grain suddenly breaks loose, burying persons who are inside the bin.

**⚠ DANGER**

Keep clear of all augers.  
**DO NOT ENTER this bin!**

If you must enter this bin:

1. Shut off and lock out all power.
2. Use safety harness and safety line.
3. Station another person outside the bin.
4. Avoid the center of the bin.
5. Wear proper breathing equipment or respirator.

Failure to heed these warnings will result in serious injury or death.

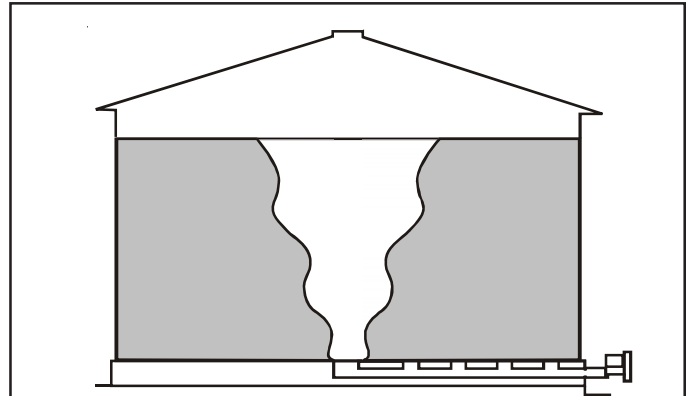

Figure 7

Abnormal grain flow can easily fall and bury a person, suffocating them. **DO NOT** enter a bin with abnormal grain flow.

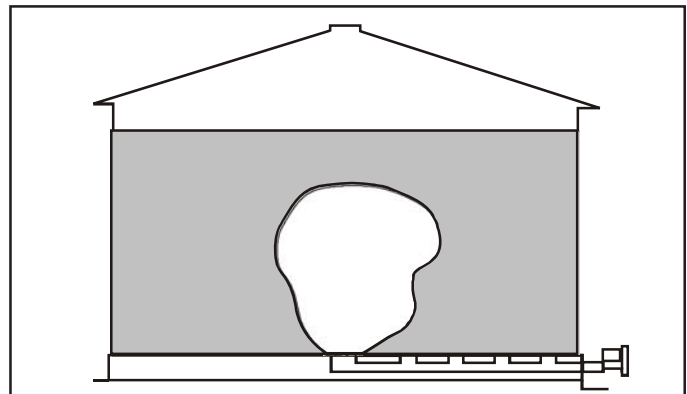

Figure 8

Bridged grain can easily break loose and bury a person, suffocating them. **DO NOT** enter a bin with bridged grain.

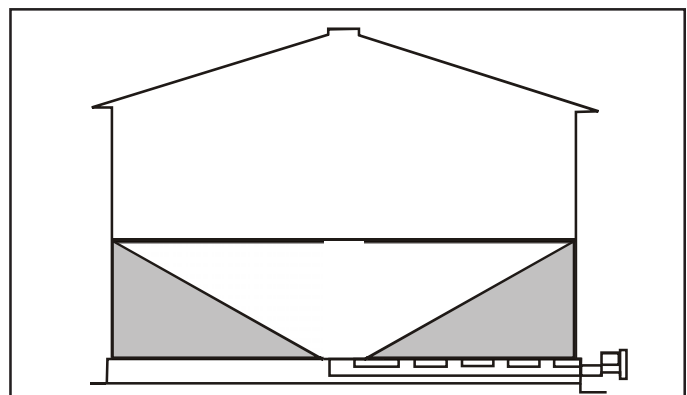
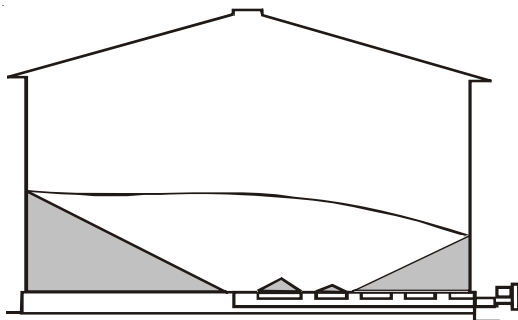

Figure 9

Grain should look similar to this. Always shut down and lock out the power to all devices before entering a bin.

- B. If the bin is equipped with intermediate bin wells, open them after grain has stopped flowing into the center well and before the sweep auger is placed in the bin. Open the intermediate wells near the bin center first. Then when grain flow stops, open the wells near the bin wall. (See Fig. 10 and Fig. 11) The Commercial Sweep Auger can then be installed. Always shut down the unloading equipment and lock out power before entering the bin.
- C. Place the sweep motor mount pivot pin into the pivot tube of the center well. Lay the sweep auger assembly on the pile of sloping grain or in the area of the intermediate wells where additional grain has been removed.



**Figure 10**

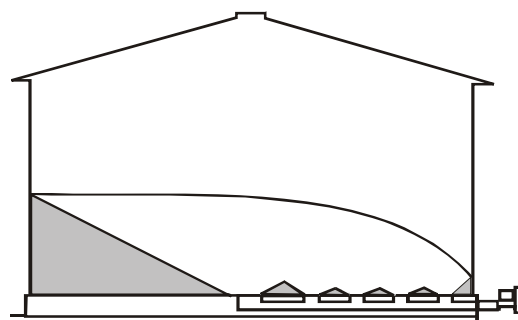
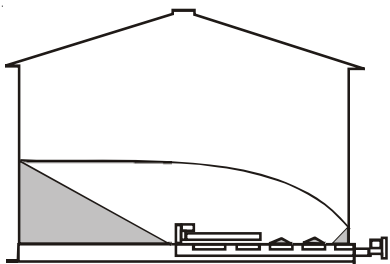

**Figure 11**



**KEEP OUT OF BIN WHILE SWEEP IS IN OPERATION.  
RAPIDLY TRAVELING SWEEP AUGER.**

- D. The Commercial Sweep Augers are made with the sweep auger and back shield in two or more sections. One of the sections can be used first alone by attaching the section to the drive unit and mounting the reduction wheel on that section. Then, after the center portion of the bin has been emptied, another section of sweep auger and back shield may be added and the unloading process continued. (See Fig. 12, 13, and 14) If the sweep is equipped with a truss, be sure to tie-off extra cable length so it does not become entangled in the sweep auger. Always shut down the unloading equipment and lock out power before entering the bin.



**1st Sweep Section Added.  
Figure 12**

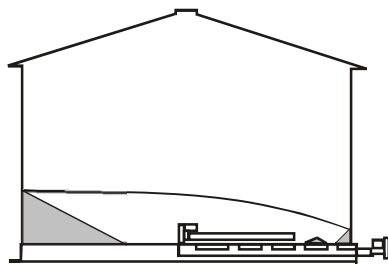

**2nd Sweep Section Added.  
Figure 13**

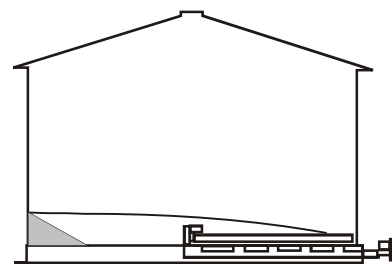

**3rd Sweep Section Added.  
Figure 14**

Using the gradual method of unloading described above helps to avoid situations where cascading grain can bury the sweep causing high torque loads and possible damage to the sweep assembly. This kind of damage is not covered by the warranty.

This type of operation may also be used to prevent the unloading of one side of the bin totally before any grain is removed from the other side. Total unloading of one side of large diameter bins without some unloading from the other side can cause structural damage to the bin. Check with your grain bin dealer or the bin manufacturer for bin unloading recommendations.

- E. Attach suitable electric wiring to the motor in a manner that will permit the sweep to rotate several times about the bin. The motor starting controls must be located outside of the bin. They must never be installed on the sweep auger inside the bin. Locate the motor starting controls outside the bin, but near the door so the operator has full view of the operation inside the bin. (See Fig 5)

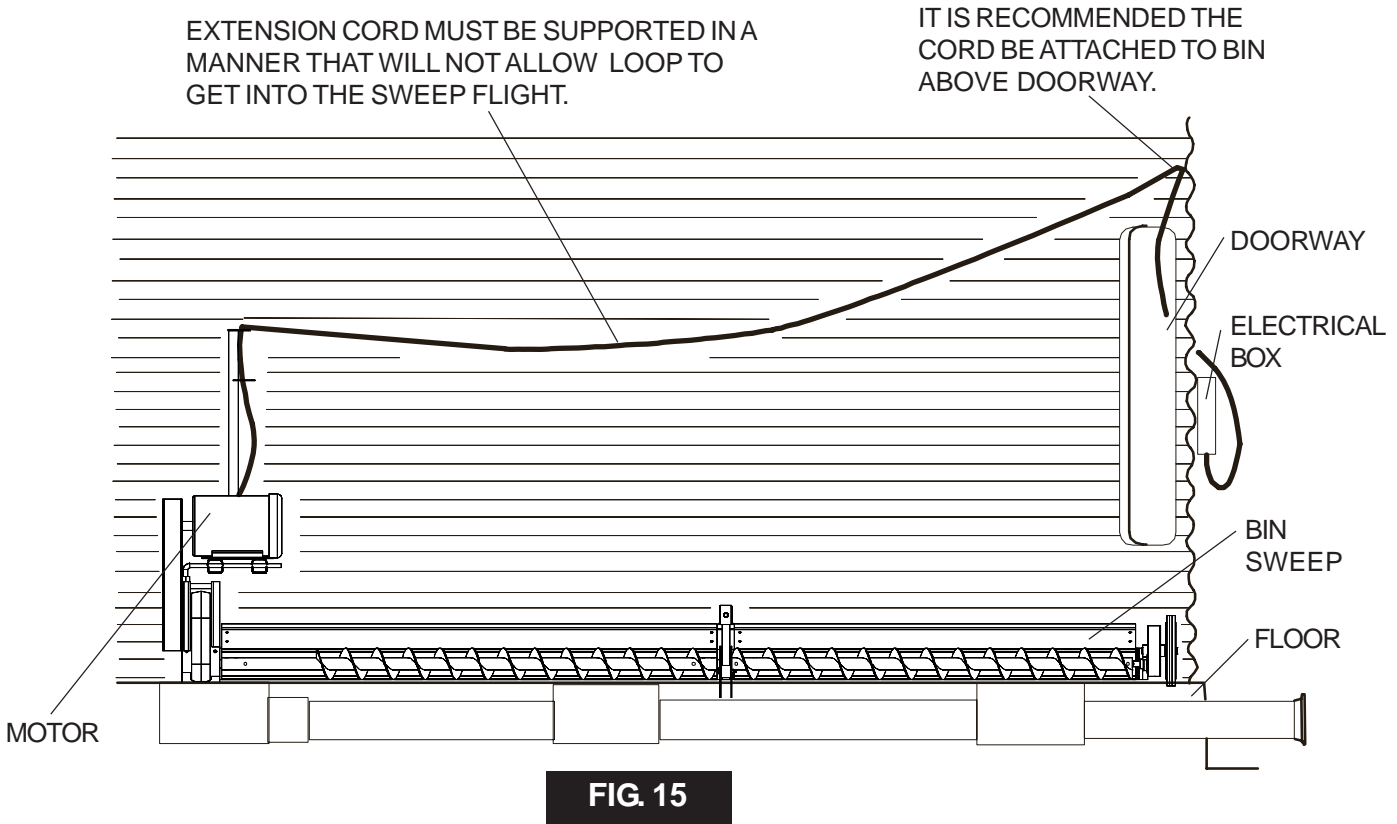

**⚠ DANGER** NEVER enter the bin while the sweep auger is in operation. Never attempt to control the operation of the sweep auger by pushing on the operating sweep auger with shovels, brooms, or other devices. DO NOT attempt to restrain movement of the sweep auger by attaching ropes, bars, or other devices to be held by an operator.

- F. Start the under floor bin unloading equipment before starting the Commercial Sweep Auger. The sweep auger will work towards the floor at approximately a 45° angle and then empty the bin or center area of the bin in one revolution after reaching the floor. As soon as the bin or center area of the bin empties, the sweep auger will rotate rapidly around the bin. Shut down the sweep auger as soon as the bin or center area of the bin is empty.

The height of the Commercial Sweep back shield above the bin floor can be adjusted at the motor mount and at the bolted connection between back shields. The back shield must be adjusted to clear the floor at least 1" to permit the reduction sweep wheel to propel the sweep properly into the grain. Be sure back shields will clear splices in metal flooring or cracks in concrete floors.

### 3. FINAL CLEAN-OUT

The following procedure is recommended for cleaning the floor of the bin after the sweep auger has removed as much grain as possible.

1. Clean (scoop and sweep by hand) the outer area of the floor into a circular pile towards the center of the bin. (See Fig. 16.)
2. Get out of the bin.
3. After making sure everyone is outside the bin and clear of the equipment, start the under floor unloader and the sweep auger. In a short time, the circular pile towards the center of the bin will have been removed.
4. Stop the equipment and lock out.
5. Scoop and sweep by hand the remaining floor area to the center of the bin. (See Fig. 17.)
6. Get out of the bin.
7. Repeat steps 3, 4, 5, and 6 until all grain has been removed from the bin.

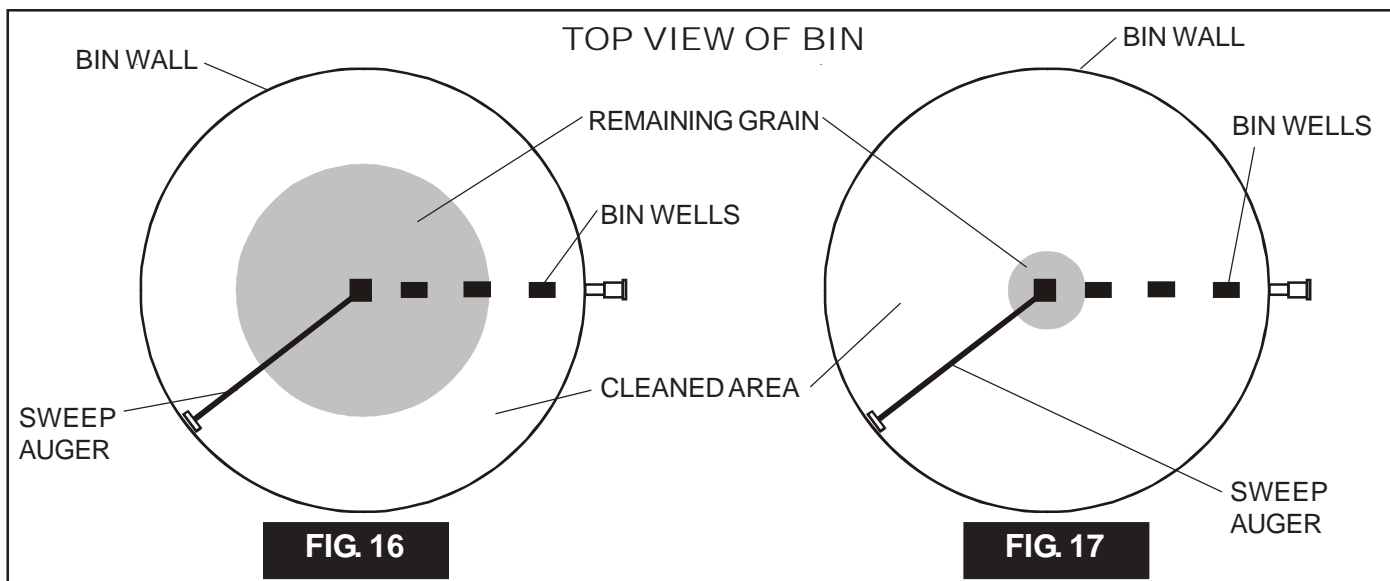

**⚠ DANGER** DO NOT enter a grain bin unless all power driven equipment has been shut down and locked out.

**⚠ DANGER** Keep out of bin while sweep is in operation. Rapidly traveling sweep auger. The sweep auger will move rapidly around the bin when the bin is nearly empty.

**⚠ DANGER** Stay clear of the under floor unloader at the bin wells. The under floor unloader is exposed at these locations in the bin floor.

**CAUTION** DO NOT STORE SWEEPS IN THE BIN!  
 Sweeps are NOT designed to remain in a bin during filling, storage, or bottom (gravity) unloading. A sweep left in a bin during these operations may be severely damaged. The GSI Group, Inc. will not be responsible for such damages.  
 The following action may reduce damages to a sweep remaining in a bin: Lifting the sweep off the center pivot, positioning it parallel to the intermediate wells (along side of - not on top of) and fully supporting the sweep to the bin floor. However, even with this procedure, The GSI group, Inc. will not be responsible for any damages to the sweep.

## 4. POWER SOURCE

The horsepower recommendations are for augering reasonably dry grain. High moisture grain (above 15%) will require greater power if maximum capacity is to be maintained. The maximum possible capacity will be less with high moisture grain than with dry grain.

**⚠ DANGER** A main power disconnect switch capable of being locked only in the off position should be used. The switch should be locked out whenever work is being done on the power sweep.

- ⚠ DANGER**
1. Electric motors and controls should be installed by a qualified electrician and must meet the standards set by the National Electrical Code and all local and state codes.
  2. A magnetic starter should be used to protect your motor when starting and stopping. It should stop the motor in case of power interruption, conductor fault, low voltage, circuit interruption or motor overload. Then the motor must be restarted manually. Some motors have built-in thermal overload protection. If this type motor is used, use only those with a manual reset.
  3. The motor starting controls must be located outside the bin. They must never be installed on the sweep auger inside the bin. Locate the motor starting controls outside the bin, but near the bin door so the operator has full view of the operation inside the bin.
  4. Disconnect power before resetting motor overloads.
  5. Reset and motor starting controls must be located so that the operator has full view of the entire operation.
  6. Make certain all electric motors are grounded.
  7. Shut off power to adjust, service or clean.

Use the tables below to determine the horsepower and electric motor pulley size your specific sweep requires. Use an electric motor that operates at 1750 RPM (motor pulley not furnished).

<b>HORSEPOWER REQUIREMENTS FOR 6" COMMERCIAL POWER SWEEP WITH 6" BIN UNLOADER</b>			
Bin Diameter	24' - 37'	39' - 60'	63' - 75'
H.P. (Electric)	2 H.P.	3 H.P.	5 H.P.
Motor Pulley	3.0" O.D.	3.0" O.D.	3.0" O.D.
Operating Flight Speed	328 R.P.M.	328 R.P.M.	328 R.P.M.

O.D. = Outside Diameter of Sheave

<b>HORSEPOWER REQUIREMENTS FOR 6" COMMERCIAL POWER SWEEP WITH 8" BIN UNLOADER</b>			
Bin Diameter	24' - 30'	33' - 48'	49' - 75'
H.P. (Electric)	2 H.P.	3 H.P.	5 H.P.
Motor Pulley	4.0" O.D.	4.0" O.D.	4.0" O.D.
Operating Flight Speed	438 R.P.M.	438 R.P.M.	438 R.P.M.

O.D. = Pitch Diameter of Sheave

Use the tables below to determine the horsepower and electric motor pulley size your specific sweep requires. Use an electric motor that operates at 1750 RPM (motor pulley not furnished).

HORSEPOWER REQUIREMENTS FOR 8" COMMERCIAL BIN SWEEP WITH 8" BIN UNLOADER			
Bin Diameter	24' - 42'	48' - 72'	75' - 92'
H.P. (Electric)	3 H.P.	5 H.P.	7.5 H.P.
Motor Pulley	3.5" O.D.	3.5" O.D.	3.5" O.D.
Operating Flight Speed	306 R.P.M.	306 R.P.M.	306 R.P.M.

O.D. = Outside Diameter of Sheave

HORSEPOWER REQUIREMENTS FOR 8" COMMERCIAL BIN SWEEP WITH 10" BIN UNLOADER			
Bin Diameter	24' - 36'	37' - 60'	63' - 92'
H.P. (Electric)	3 H.P.	5 H.P.	7.5 H.P.
Motor Pulley	4.5" O.D.	4.5" O.D.	4.5" O.D.
Operating Flight Speed	394 R.P.M.	394 R.P.M.	394 R.P.M.

O.D. = Outside Diameter of Sheave

## 5. BELT TENSION

Check the belt tension on electric drive. To tighten belt, use the two adjusting nuts on the rod assemblies. **DO NOT** over tighten belts.

## 6. ENCLOSED DRIVE LUBRICATION

The enclosed drive is located at the discharge end of the auger housing and is shipped without oil. Oil is to be added to the unit during field assembly of the auger. Oil will dissipate under normal operating conditions, therefore the oil level should be checked regularly. Add 90 EP (non-foaming) oil until the oil level reaches the check point.

For lubrication in normal operating temperature between 40° F to 120° F, we recommend the use of non-foaming, multi purpose gear oil. Use SAE 90 weight for normal operating temperatures. For temperatures below 40° F, use SAE 80 weight oil. Use a grade of oil commercially available for automotive differentials. Extra pressure additives may be of value in severe applications.

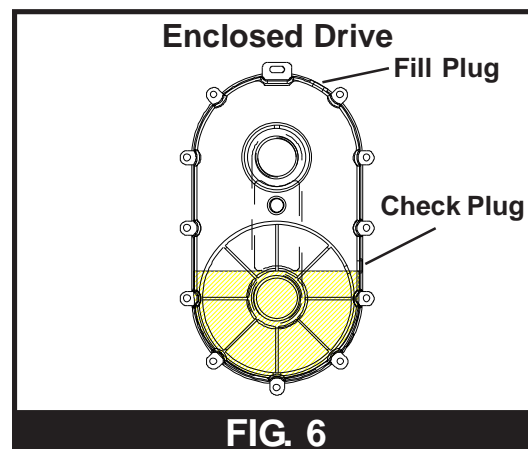

**DO NOT** add more oil than recommended. Additional oil may damage the seals or be forced out through the vented plug.

## 7. REDUCTION SWEEP WHEEL

Add two ounces of multi purpose gun grease to the sweep wheel drive enclosure during assembly and each time the bin has been emptied. Use the grease zerk on the drive housing.

## 8. TROUBLE SHOOTING

### A. LOW CAPACITY

Sweep capacity may vary as the angle of sloping grain varies. Check the horsepower requirements on pages 22-23, to determine correct operating speed and the motor pulley size recommended for that speed. If a greater or lower capacity is desired it may be possible to change the motor pulley which will change the sweep flight speed. Do not attempt operation at speeds greater than 50 to 100 RPM above standard recommended speed. Do not operate a sweep that is overfeeding the unloading auger unit. The slide gate in the center well should be left full open during sweep operation.

### B. SWEEP FLIGHT & BACK SHIELD NOT MOVING

#### DO NOT STORE SWEEPS IN THE BIN!

Sweeps are NOT designed to remain in a bin during filling, storage, or bottom (gravity) unloading. A sweep left in a bin during these operations may be severely damaged. The GSI Group, Inc. will not be responsible for such damages.

The following action may reduce damages to a sweep remaining in a bin: Lifting the sweep off the center pivot, positioning it parallel to the intermediate wells (along side of - not on top of) and fully supporting the sweep to the bin floor. However, even with this procedure, The GSI group, Inc. will not be responsible for any damages to the sweep.

Check clearance between back shield and the bin floor for excessive drag. It may be possible to adjust the back shield up by working the slotted connections between back shields at bearing brackets.

The grain may have gone out of condition due to moisture or insect activity and has become hard or caked. Stop the sweep auger and lockout power before entering the bin to correct this or any other difficulty. Make sure the grain hasn't flowed abnormally or bridged over. See page 18 for illustrations.



## 6" & 8" COMMERCIAL BIN SWEEP FLIGHT & SHIELDS

6" FLIGHT & SHIELD BUNDLES		
Bundle #	Part #	Description
GK5014	--	-- --
	GK4534	6' - 6-1/2" Shield
	GK4665	6' - 6-1/2" Flight w/ Cutback
GK5015	--	-- --
	GK4536	9' - 6-1/2" Shield
	GK4667	9' - 6-1/2" Flight w/ Cutback
GK5016	--	-- --
	GK4535	8' - 1/2" Shield
	GK4666	8' - 1/2" Flight w/ Cutback
GK5017	--	-- --
	GK4537	5' - 10" Shield
	GK2134	5' - 10" Flight
GK5018	--	-- --
	GK4538	8' - 10" Shield
	GK2129	8' - 10" Flight
GK5019	--	-- --
	GK2116	3' - 9-1/2" Shield
	GK2117	3' - 9-1/2" Flight
GK5020	--	-- --
	GK2119	5' - 3-1/2" Shield
	GK2120	5' - 3-1/2" Flight
GK5021	--	-- --
	GK2114	6' - 9-1/2" Shield
	GK2115	6' - 9-1/2" Flight
GK5022	--	-- --
	GK2136	9' - 3-1/2" Shield
	GK2137	9' - 3-1/2" Flight
GK5023	--	-- --
	GK2122	9' - 9-1/2" Shield
	GK2123	9' - 9-1/2" Flight
GK5024	--	-- --
	GK2125	8' - 3-1/2" Shield
	GK2126	8' - 3-1/2" Flight

8" FLIGHT & SHIELD BUNDLES		
Bundle #	Part #	Description
GK4824	--	-- --
	GK4741	6' - 6-1/2" Shield
	GK4718	6' - 6-1/2" Flight w/ Cutback
GK4825	--	-- --
	GK4747	9' - 6-1/2" Shield
	GK4720	9' - 6-1/2" Flight w/ Cutback
GK4826	--	-- --
	GK4743	8' - 1/2" Shield
	GK4719	8' - 1/2" Flight w/ Cutback
GK4827	--	-- --
	GK4740	5' - 10" Shield
	GK2080	5' - 10" Flight
GK4828	--	-- --
	GK4745	8' - 10" Shield
	GK2074	8' - 10" Flight
GK4829	--	-- --
	GK4738	3' - 9-1/2" Shield
	GK1956	3' - 9-1/2" Flight
GK4830	--	-- --
	GK4739	5' - 3-1/2" Shield
	GK1961	5' - 3-1/2" Flight
GK4831	--	-- --
	GK4742	6' - 9-1/2" Shield
	GK1958	6' - 9-1/2" Flight
GK4832	--	-- --
	GK4746	9' - 3-1/2" Shield
	GK2088	9' - 3-1/2" Flight
GK4833	--	-- --
	GK4748	9' - 9-1/2" Shield
	GK1964	9' - 9-1/2" Flight
GK4834	--	-- --
	GK4744	8' - 3-1/2" Shield
	GK1967	8' - 3-1/2" Flight

# CARRIER WHEEL ASSEMBLY

See illustration below for reference numbers.

Ref #	Part #	Description
1	GK2082	Frame Weldment
2	GK2083	Spindle and Wheel Assembly
3	GK2084	Spindle Weldment
4	GK2085	Wheel Disc 10 Ga. Black 8 1/8" O.D.
5	GK2086	Spindle Bushing, 1 1/4" O.D. x 1 5/8" Long
6	S-6762	3/8" x 2 1/4" Bolt, Grade 5

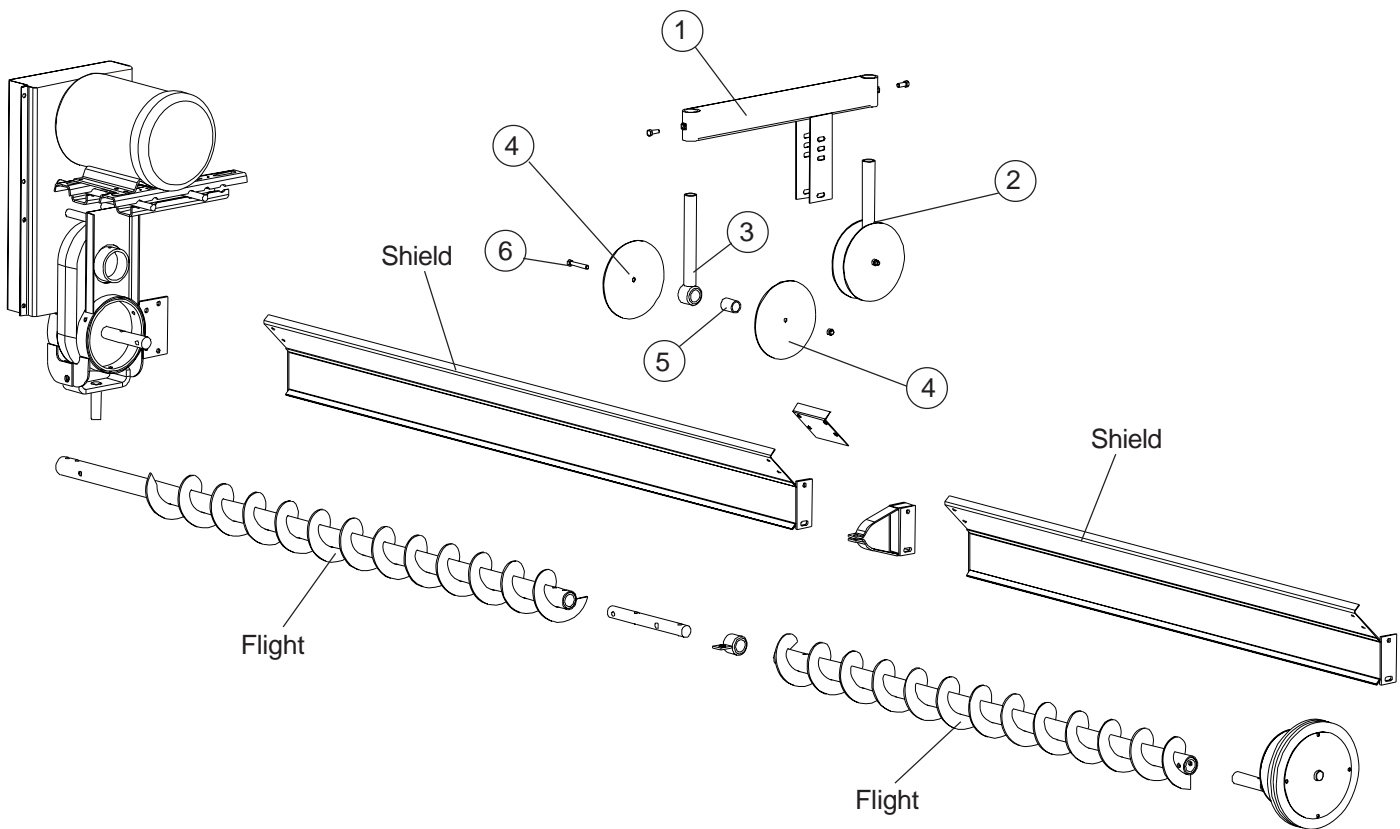

# 6", 8", & 10" COMMERCIAL BIN SWEEP PARTS

## 6" & 8" COMMERCIAL SWEEP PARTS FOR 24' - 60' BINS

Ref #	Part #	Description
1	GK5361	Motor Mount Rod
2	GK1341	Motor Mount Bottom Strap
3	GK1342	Motor Mount Top Strap
4	GK1736	Shaft Connector 1-1/4" O.D. x 11-1/2" - 6"
	GK1951	Shaft Connector 1-1/2" O.D. x 11-1/2" - 8"
5	GK1952	V B-50 Belt - 6"
	GK2349	V B-54 Belt - 8"
6	GK2107	Shield Bearing Bracket - 6"
	GK1954	SB 10" Bearing Stand Assembly -8"
7	GK4203	Electric Cord Support Stand
8	GK4204	Sweep Shield & Drive Frame
9	GK4205	1" I.D. x 1-1/4" O.D. x 4-3/8" Long Bushing - 6"
	GK4206	1" I.D. x 1-1/2" O.D. x 4-3/8" Long Bushing - 8"
10	GK4207	1/4" Spacer Plate - 6"
	GK4224	1/4" Spacer Plate - 8"
11	GK4208	12 Gauge Spacer Plate - 6"
	GK4225	12 Gauge Spacer Plate - 8"
12	GK4209	14 Gauge Spacer Plate - 6"
	GK4226	14 Gauge Spacer Plate - 8"
13	GK4220	Belt Guard and Motor Mount Frame
14	GK4222	Center Pivot Weldment
15	GK4229	Splice Plate for Shield
16	GK4250	Belt Guard Spacer Pipe
17	GK4840	Enclosed Chain Drive (2 to 1) - 6"
	GK4841	Enclosed Chain Drive (2 to 1) - 8"
18	GK4842	8" x 1" Bore 2 Belt Aluminum Sheave
	GK1983	10" x 1" Bore 2 Belt Aluminum Sheave
19	GK4230	Reduction Wheel (4 to 1) - 6"
	GK4231	Reduction Wheel (4 to 1) - 8"
20	GK2078	Carrier Wheel Assembly
21	S-8072	5/16" - 18 x 3/4" Zinc Grade 2 HHCS Bolt
22	S-7382	5/16" - 18 Zinc Grade 5 Nylock Nut
23	S-7469	3/8" - 16 x 1" Zinc Grade 5 HHCS Bolt
24	S-8231	3/8" - 16 x 1-1/4" Zinc Grade 5 Carriage Bolt
25	S-3727	3/8" - 16 x 1-3/4" Zinc Grade 8 HHCS Bolt
26	S-6762	3/8" -16 x 2-1/2" Zinc Grade 5 HHCS Bolt
27	S-7249	3/8" -16 x 3" Zinc Grade 5 HHCS Bolt
28	S-8055	3/8" - 16 x 3" Zinc Carriage Bolt
29	S-248	3/8" Flat Washer USS Zinc Grade 2 YDP
30	S-7383	3/8" - 16 Zinc Grade 5 Nylock Nut
31	S-3886	7/16" - 14 x 1-1/4" Zinc Grade 5 HHCS Bolt
32	S-7013	7/16" - 14 x 2-1/2" Zinc Grade 5 HHCS Bolt
33	S-8320	7/16" USS Zinc Flat Washer
34	S-8234	7/16" - 14 Zinc Grade 5 Nylock Nut
35	S-8232	1/2" - 13 x 4-1/2" Zinc Grade 5 HHCS Bolt
36	S-8260	1/2" - 13 Zinc Grade 5 Nylock Nut
37	S-8252	1/2" - 13 x 3" Zinc Grade 8 HHCS Bolt
38	S-4329	5/8" -11 x 2" Zinc Grade 8 HHCS Bolt
39	S-8349	5/8" -11 Zinc Grade 2 Nylock Nut
40	S-3214	7/8" - 9 Zinc Grade 2 Hex Nut
41	S-8276	1/4" x 1/4" x 3" Long Square Key
42	GK5610	Belt Guard Back Plate

# 6", 8", & 10" COMMERCIAL BIN SWEEP PARTS

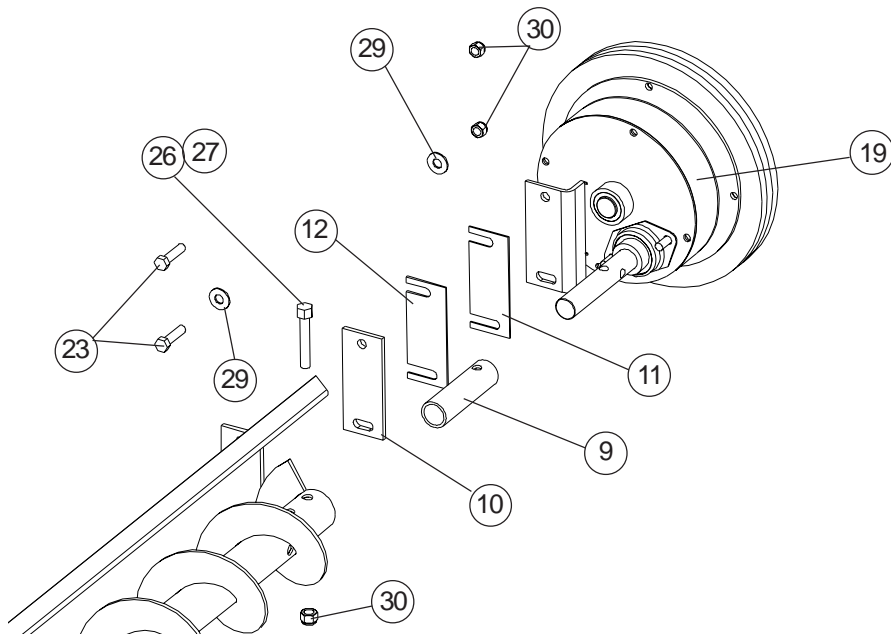
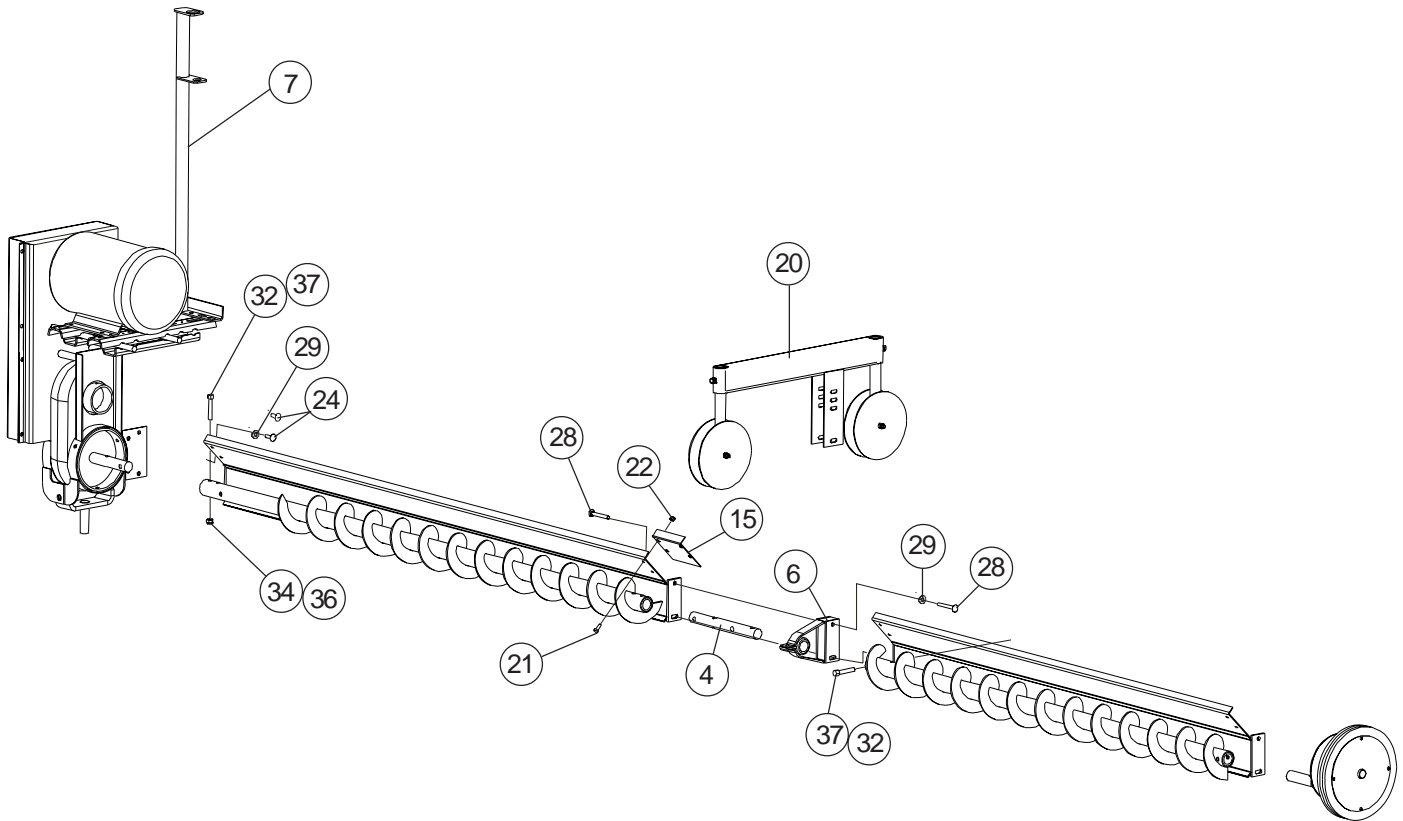

# 6", 8", & 10" COMMERCIAL BIN SWEEP PARTS

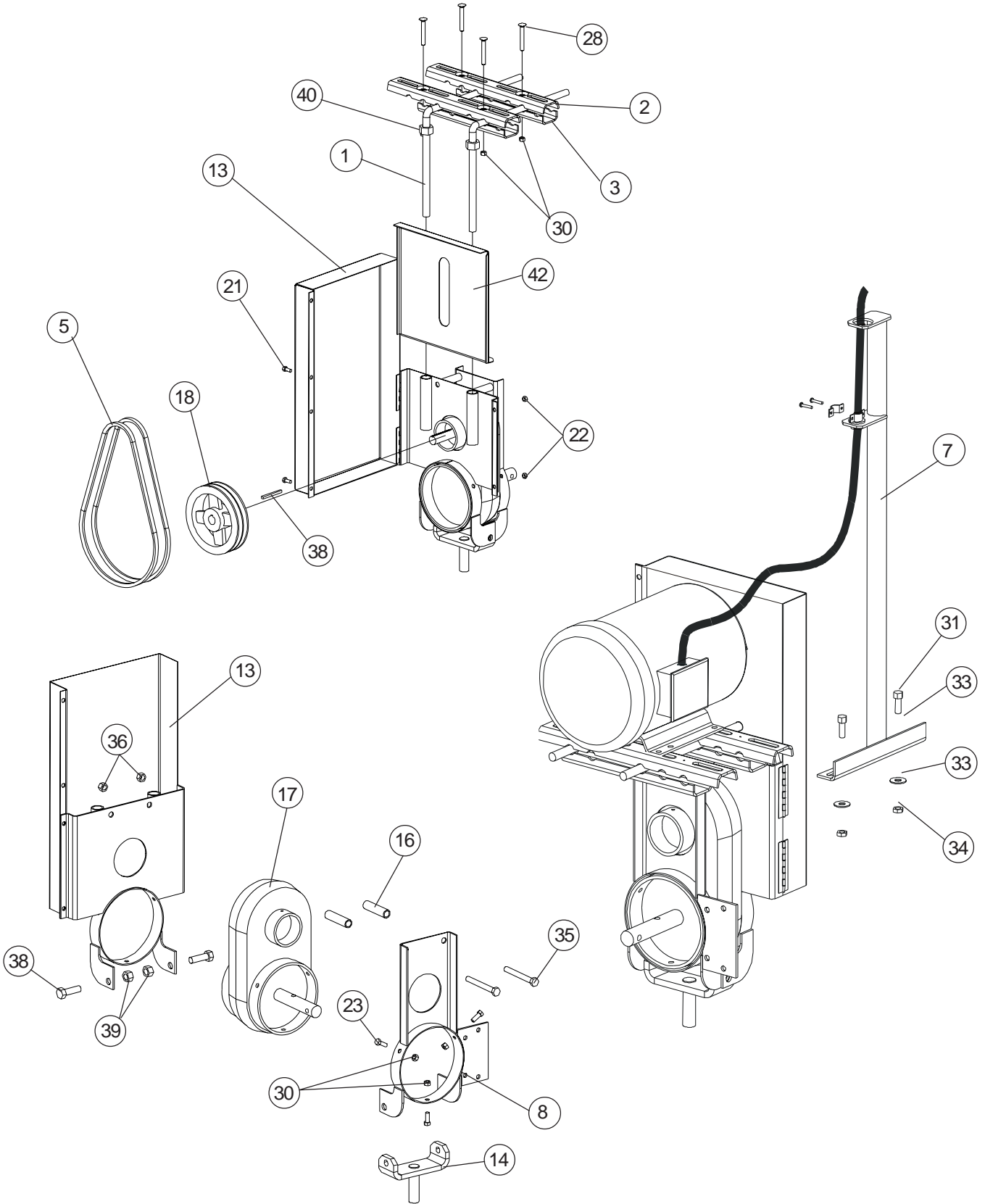

# REDUCTION WHEEL

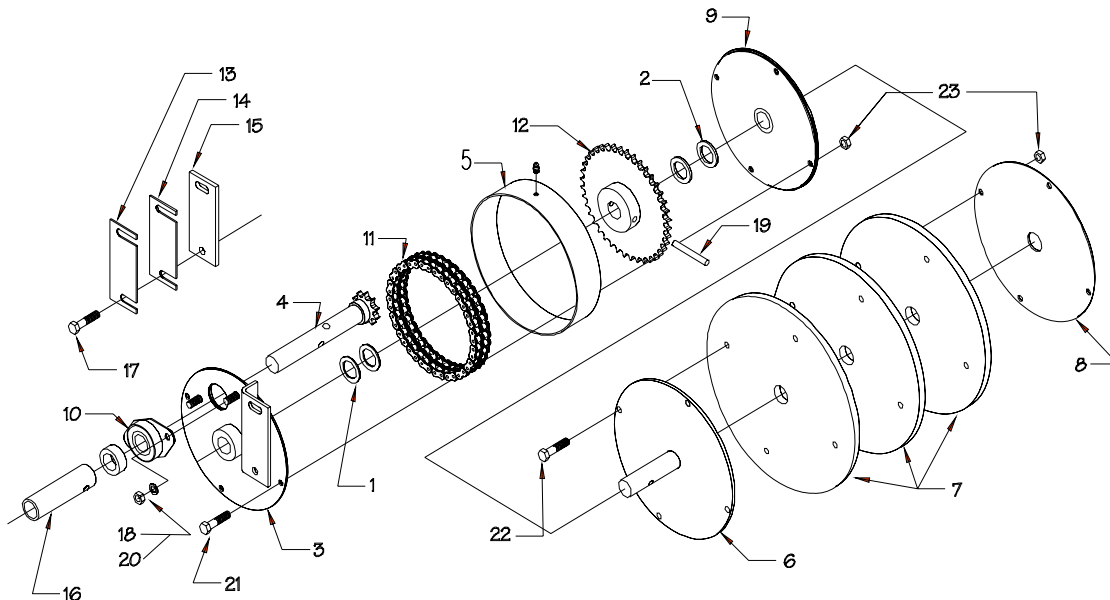

Ref #	Part #	Description
1	GK4210	1" x 1-1/2" 14 Ga. Galvanized Flat Washer
2	GK4211	1" x 1-1/2" 10 Ga. Galvanized Flat Washer
3	GK4213	Inner Drive Housing with Bushing -6"
	GK4228	Inner Drive Housing with Bushing -8"
4	GK4214	Drive Shaft Weldment 10T #40
5	GK4215	Housing Ring with Zerk
6	GK4217	Inner Wheel Weldment - 6"
	GK4242	Inner Wheel Weldment - 8"
7	GK4218	Rubber Wheel Disk 11" O.D. - 6"
	GK4241	Rubber Wheel Disk 13" O.D. - 8"
8	GK4219	Outer Wheel Disk - 6"
	GK4240	Outer Wheel Disk - 8"
9	GK4223	Outer Drive Housing with Bushing
10	GK4232	1" Bearing with 2 Hole Flange
11	GK4233	Chain Roller - #40 Double with Link
12	GK4234	40 Tooth Sprocket with Hub
13	GK4209	14 Gauge Spacer Plate - 6"
	GK4226	14 Gauge Spacer Plate - 8"
14	GK4208	12 Gauge Spacer Plate - 6"
	GK4225	12 Gauge Spacer Plate - 8"
15	GK4207	1/4" Spacer Plate - 6"
	GK4224	1/4" Spacer Plate - 8"
16	GK4205	1" I.D. x 1-1/4" O.D. x 4-3/8" Long Bushing - 6"
	GK4206	1" I.D. x 1-1/2" O.D. x 4-3/8" Long Bushing - 8"
17	GK3727	3/8" - 16 x 1-3/4" Zinc Grade 8 HHCS Bolt
18	S-1054	3/8" Zinc Split Lock Washer
19	S-4383	5/16" x 2-1/4" Rolled PinSpring
20	S-456	3/8" Zinc YDP Grade 5 Hex Nut
21	S-7076	5/16" - 18 x 2-1/2" Zinc Grade 5 HHCS Bolt
22	S-7329	5/16" - 18 x 2" Zinc Grade 2 HHCS Bolt
23	S-7382	5/16" - 18 zinc Grade 5 Nylock Nut

## 2 TO 1 ENCLOSED CHAIN DRIVE

2 TO 1 ENCLOSED CHAIN DRIVE		
Ref #	Part #	Description
1	GK6349	Aluminum Casting Cover (Inside)
2	GK3247	1" Bearing cup (Timken No. 07204)
3	GK3242	1" Bearing cone (Timken No. 07100)
4	GK2383	1-1/4" Bearing Cup (Timken No. 15245)
5	GK2367	1-1/4" Bearing Cone (Timken No. 15123)
6	GK6346	Input Shaft - 1"
7	GK5217	1" Bore Sprocket, #60 13 Tooth
8	GK6343	Aluminum Casting Cover (Inside)
9	GK6344	Output Shaft - 1-1/4" - 6"
	GK6345	Output Shaft - 1-1/2" - 1-1/4" - 8"
10	GK5991	#60 Roller Chain - 39 Pitch
11	GK5990	1-1/4" Bore Sprocket, #60 39 Tooth
12	GK6328	Machinery Bushing, 1" ID x .075" Thick
13	DC-1512	Decal: Notice Oil Level 3 Pint
14	GK2374	Output Shaft Oil Seal - 1-1/4"
15	GK3251	Input Shaft Oil Seal - 1"
16	GK5350	Pipe Bushing, 1/8"x3/8" NPT
17	GK2697	Vent Plug, 1/8" NPT
18	S-8675	Nut, 5/16-18 Whiz Lock
19	FLX-3788	Drain Plug - 1/4" NPT
20	DC-1689	Decal: 2.0 To 1.0 Ratio
21	S-4276	Bolt, HHTB, 5/16-18 x 1-1/4" ZN GR5
22	S-7245	Pin, Grooved Spring, 3/8" x 2-1/2"
23	3358A1	Pin, Grooved Spring, 3/8" x 2-1/4"
24	S-9168	Square Key 1/4" x 1"
25	GK6782	Machinery Bushing, 1" ID x .048" Thick
26	GK7794	Shim, .020 Thk x 1.25ID x 1.75 OD
27	GK7734	Wave Spring
28	GK7812	Wave Spring
29	GK7516	Blue RTV Silicone Gasket Maker

## 2 TO 1 ENCLOSED CHAIN DRIVE

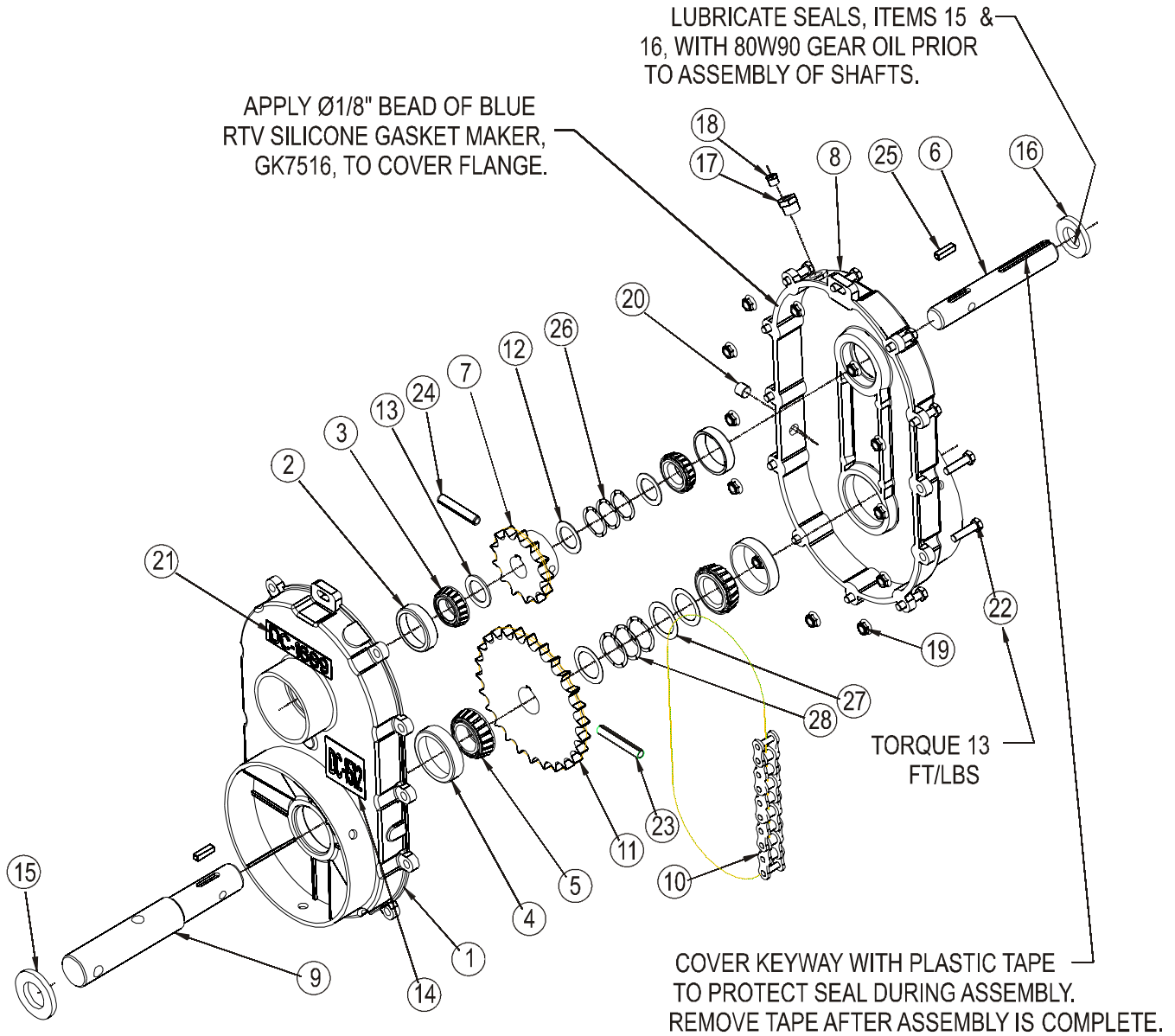



---

## The GSI Group, Inc. Warranty

THE GSI GROUP, INC. ("GSI") WARRANTS ALL PRODUCTS WHICH IT MANUFACTURES TO BE FREE OF DEFECTS IN MATERIAL AND WORKMANSHIP UNDER NORMAL USAGE AND CONDITIONS FOR A PERIOD OF 12 MONTHS AFTER RETAIL SALE TO THE ORIGINAL END USER. THE PURCHASER'S SOLE REMEDY AND GSI'S ONLY OBLIGATION SHALL BE TO REPAIR OR REPLACE, AT GSI'S OPTION AND EXPENSE, PRODUCTS THAT, IN GSI'S SOLE JUDGMENT, CONTAIN A MATERIAL DEFECT DUE TO MATERIALS OR WORKMANSHIP. ALL DELIVERY AND SHIPMENT CHARGES TO AND FROM GSI'S FACTORY WILL BE PURCHASER'S RESPONSIBILITY. EXPENSES INCURRED BY OR ON BEHALF OF THE PURCHASER WITHOUT PRIOR WRITTEN AUTHORIZATION FROM AN AUTHORIZED EMPLOYEE OF GSI SHALL BE THE SOLE RESPONSIBILITY OF THE PURCHASER.

EXCEPT FOR THE LIMITED WARRANTY EXPRESSED ABOVE, GSI MAKES NO FURTHER WARRANTY OF ANY KIND, EXPRESS OR IMPLIED, INCLUDING, WITHOUT LIMITATION, WARRANTIES OF MERCHANTABILITY OR FITNESS FOR A PARTICULAR PURPOSE OR USE IN CONNECTION WITH (I) PRODUCT MANUFACTURED OR SOLD BY GSI OR (ii) ANY ADVICE, INSTRUCTION, RECOMMENDATION OR SUGGESTION PROVIDED BY AN AGENT, REPRESENTATIVE OR EMPLOYEE OF GSI REGARDING OR RELATED TO THE CONFIGURATION, INSTALLATION, LAYOUT, SUITABILITY FOR A PARTICULAR PURPOSE, OR DESIGN OF SUCH PRODUCTS.

GSI SHALL NOT BE LIABLE FOR ANY DIRECT, INDIRECT, INCIDENTAL OR CONSEQUENTIAL DAMAGES, INCLUDING, WITHOUT LIMITATION, LOSS OF ANTICIPATED PROFITS OR BENEFITS. PURCHASER'S SOLE AND EXCLUSIVE REMEDY IS AS SET FORTH IN THE LIMITED WARRANTY EXPRESSED ABOVE, WHICH SHALL NOT EXCEED THE AMOUNT PAID FOR THE PRODUCT PURCHASED. THIS WARRANTY IS NOT TRANSFERABLE AND APPLIES ONLY TO THE ORIGINAL PURCHASER. GSI SHALL HAVE NO OBLIGATION OR RESPONSIBILITY FOR ANY REPRESENTATIONS OR WARRANTIES MADE BY OR ON BEHALF OF ANY DEALER, AGENT OR DISTRIBUTOR OF GSI.

GSI ASSUMES NO RESPONSIBILITY FOR CLAIMS RESULTING FROM ERECTION DEFECTS OR UNAUTHORIZED MODIFICATIONS TO PRODUCTS WHICH IT MANUFACTURED. MODIFICATIONS TO PRODUCTS NOT SPECIFICALLY DELINEATED IN THE MANUAL ACCOMPANYING THE EQUIPMENT AT INITIAL SALE WILL NULLIFY THE PRODUCT WARRANTY THAT MIGHT HAVE BEEN OTHERWISE AVAILABLE.

THE FOREGOING WARRANTY SHALL NOT EXTEND TO PRODUCTS OR PARTS WHICH HAVE BEEN DAMAGED BY NEGLIGENT USE, MISUSE, ALTERATION OR ACCIDENT. THIS WARRANTY EXTENDS SOLELY TO ONLY PRODUCTS MANUFACTURED BY GSI. THIS WARRANTY IS EXCLUSIVE AND IN LIEU OF ALL OTHER WARRANTIES EXPRESS OR IMPLIED. GSI RESERVES THE RIGHT TO MAKE DESIGN OR SPECIFICATION CHANGES AT ANY TIME.

PRIOR TO INSTALLATION, PURCHASER HAS THE RESPONSIBILITY TO COMPLY WITH ALL FEDERAL, STATE AND LOCAL CODES WHICH MAY APPLY TO THE LOCATION AND INSTALLATION OF PRODUCTS MANUFACTURED OR SOLD BY GSI.

---

This Equipment shall be installed in accordance with the current installation codes and applicable regulations which should be carefully followed in all cases. Authorities having jurisdiction should be consulted before installation occurs.

**G S I G R O U P**



1004 East Illinois Street  
Assumption, IL 62510  
Ph: 217-226-4421  
Fax: 800-800-5329  
Int'l Tel: 1-217-226-4401  
Int'l Fax: 1-217-226-3404  
Internet: <http://www.grainsystems.com>