

6"-8" and 8"-10" Commercial Bin Sweep Augers

Assembly and Operation Manual

PNEG-1048

Version: 4.0

Date: 03-10-20



Personnel operating or working around this equipment should read this manual. This manual must be delivered with equipment to its owner. Failure to read this manual and its safety instructions is a misuse of the equipment. Any misuse of the equipment may void the warranty.

Contents

Chapter 1 Introduction	4
General Information	4
Receiving Merchandise and Filing Claims	4
Chapter 2 Safety	5
Safety Guidelines	5
Cautionary Symbols Definitions	6
Safety Cautions	7
Safety Sign-Off Sheet	10
Chapter 3 Safety Decals	11
Chapter 4 Assembly Instructions	14
Motor Mount Assembly Instructions	14
Electrical Cord Support Stand Assembly	17
Assembling Sweep Flight and Back Shield Assembly	18
Sweep Wheel Installation	20
Chapter 5 Installation	21
Installation Procedures	21
Final Clean Out	25
Chapter 6 Operating Procedures	26
Power Source	26
Chapter 7 Maintenance	27
Belt Tension	27
Enclosed Drive Lubrication	27
Reduction Sweep Wheel	28
Troubleshooting	28
Chapter 8 Parts List	29
6" and 8" Commercial Bin Sweep Flight and Shields	30
Carrier Wheel Assembly	31
6", 8" and 10" Commercial Bin Sweep Parts	32
2 to 1 Enclosed Chain Drive	36
Chapter 9 Warranty	39

1. Introduction

General Information

1. We reserve the right to improve our product whenever possible and practical to do so. We reserve the right to change, improve and modify products at any time without obligation to make changes, improvements and modifications on equipment sold previously.
2. The Commercial Bin Sweeps have been designed and manufactured to give years of dependable service. The care and maintenance of this machine will affect the satisfaction and service obtained. By observing the instructions and suggestions we have recommended, the owner should receive competent service for many years. If additional information or assistance should be required, please contact the factory or the local dealer.

Receiving Merchandise and Filing Claims

When receiving merchandise, it is important to check both the quantity of parts and their descriptions with the packing list enclosed within each package. All claims for freight damage or shortage must be made by the consignee within ten (10) days from the date of the occurrence of freight damage. The consignee should accept the shipment after noting the damage or loss.



DO NOT STORE SWEEPS IN THE BIN.

Sweeps are NOT designed to remain in a bin during filling, storage or bottom (gravity) unloading. A sweep left in a bin during these operations may be severely damaged. The GSI Group will not be responsible for such damages.

The following action may reduce damages to a sweep remaining in a bin: Lifting the sweep off the center pivot, positioning it parallel to the intermediate wells (along side of - not on top of) and fully supporting the sweep to the bin floor. However, even with this procedure, the GSI Group will not be responsible for any damages to the sweep.

Safety Guidelines

Safety guidelines are general-to-specific safety rules that must be followed at all times. This manual is written to help you understand safe operating procedures and problems that can be encountered by the operator and other personnel when using this equipment. Read and save these instructions.

As owner or operator, you are responsible for understanding the requirements, hazards, and precautions that exist and to inform others as required. Unqualified persons must stay out of the work area at all times.

Alterations must not be made to the equipment. Alterations can produce dangerous situations resulting in **SERIOUS INJURY** or **DEATH**.

This equipment must be installed in accordance with the current installation codes and applicable regulations, which must be carefully followed in all cases. Authorities having jurisdiction must be consulted before installations are made.

When necessary, you must consider the installation location relative to electrical, fuel and water utilities.

Personnel operating or working around equipment must read this manual. This manual must be delivered with equipment to its owner. Failure to read this manual and its safety instructions is a misuse of the equipment.

ST-0001-4

Cautionary Symbols Definitions

Cautionary symbols appear in this manual and on product decals. The symbols alert the user of potential safety hazards, prohibited activities and mandatory actions. To help you recognize this information, we use the symbols that are defined below.



This symbol indicates an imminently hazardous situation which, if not avoided, **will result in serious injury or death.**



This symbol indicates a potentially hazardous situation which, if not avoided, **can result in serious injury or death.**



This symbol indicates a potentially hazardous situation which, if not avoided, **can result in minor or moderate injury.**



This symbol is used to address practices not related to personal injury.



This symbol indicates a general hazard.



This symbol indicates a prohibited activity.



This symbol indicates a mandatory action.

ST-0005-2

Safety Cautions

Use Personal Protective Equipment

- Use appropriate personal protective equipment:

Eye Protection



Respiratory Protection



Foot Protection



Hearing Protection



Head Protection



Fall Protection



Hand Protection



- Wear clothing appropriate to the job.
- Remove all jewelry.
- Tie long hair up and back.

ST-0004-1

Follow Safety Instructions

- Carefully read all safety messages in this manual and safety signs on your machine. Keep signs in good condition. Replace missing or damaged safety signs. Be sure new equipment components and repair parts include the current safety signs. Replacement safety signs are available from the manufacturer.
- Learn how to operate the machine and how to use controls properly. Do not let anyone operate without instruction.
- If you do not understand any part of this manual or need assistance, contact your dealer.



ST-0002-1

2. Safety

Maintain Equipment and Work Area

- Understand service procedures before doing work. Keep area clean and dry.
- Never service equipment while it is operating. Keep hands, feet, and clothing away from moving parts.
- Keep your equipment in proper working condition. Replace worn or broken parts immediately.



ST-0003-1

Operate Motor Properly

- All electrical connections must be made in accordance with applicable local codes (National Electrical Code for the US, Canadian Electric Code, or EN60204 along with applicable European Directives for Europe). Make sure equipment and bins are properly grounded.
- Lock-out power before resetting motor overloads.
- Do not repetitively stop and start the drive in order to free a plugged condition. Jogging the drive in this manner can damage the equipment and drive components.

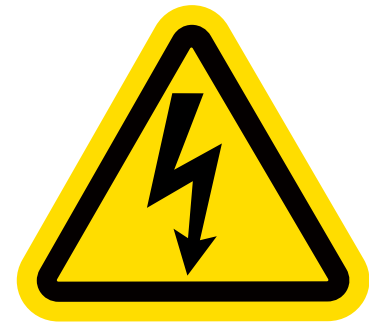

ST-0009-3

Rotating Auger Hazard

- Keep clear of rotating augers and moving parts.
- Do not remove or modify guards or covers.
- Lock-out power source before making adjustments, cleaning, or maintaining equipment.
- Failure to follow these precautions will result in serious injury or death.



ST-0037-1

Stay Clear of Hoisted Equipment

- Always use proper lifting or hoisting equipment when assembling or disassembling equipment.
- Do not walk or stand under hoisted equipment.
- Always use sturdy and stable supports when needed for installation. Not following these safety precautions creates the risk of falling equipment, which can crush personnel and cause serious injury or death.



ST-0047-1

Stay Clear of Rotating Parts

- Do not enter the bin while the equipment is in operation.
- Entanglement in rotating augers will cause serious injury or death.
- Keep all guards and covers in place at all times.
- Lock-out power source before making adjustments, cleaning, or maintaining equipment.



ST-0008-2



Use Unload Equipment Properly

- Do not operate this equipment alone. Make sure someone nearby is aware of the proper shut down sequence in the event of an emergency.
- Do not allow any person intoxicated or under the influence of drugs to operate this equipment. All operators must be adequately rested and prepared to perform all functions of operating the equipment.
- Do not start equipment until all persons are clear of the work area and safety guards are in place.
- Do not allow anyone inside a bin, truck, or wagon which is being unloaded by an auger. Flowing grain can trap and suffocate in seconds.
- Use ample overhead lighting after sunset to light the work area.
- Always use caution to not hit the auger when positioning the load.
- Do not leave equipment operating while unattended.
- Be aware of pinch points, which can trap or catch objects and cause injury.
- Be sure all equipment is locked in position before operating.
- Always lock out all power sources to the equipment when unloading is finished.



ST-0051-1

Check components shown below to ensure that the safety decals are in place and in good condition. If a decal cannot be easily read for any reason or has been painted over, replace it immediately. Contact your dealer or the manufacturer to order a replacement decal free of charge.

	<p> DANGER</p>
<p>GSI Group 217-226-4421</p>	<p>RAPIDLY TRAVELLING SWEEP AUGER</p>
	<p>Keep out of bin while sweep is in operation.</p>
	<p>Failure to heed will result in serious injury or death.</p>
	<p>DC-1384</p>

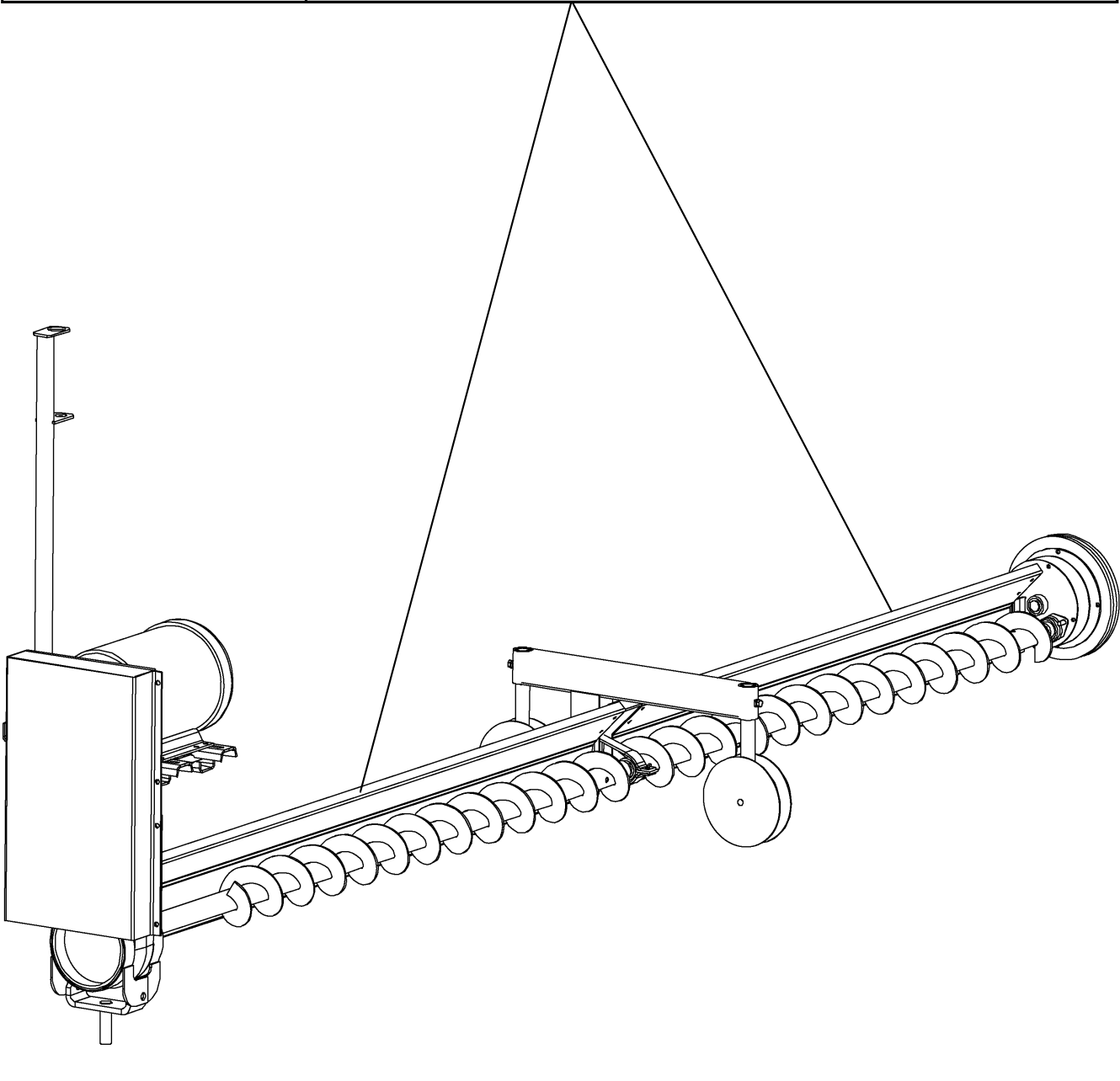

3. Safety Decals

- A. DANGER Sign No. DC-1395 was supplied with your bin unloading equipment. This safety sign should be applied to the side of the bin near the bin opening, so it will be viewed by people entering into the bin storage building. Do not cover any safety signs or any other signs that are already there.
- B. If the safety sign location suggested is not in full view because of equipment modifications, other equipment in the area or any reason, then locate the safety sign in a more suitable location.
- C. Be certain the surface is clean, dry and free of dirt and oil. Peel paper backing from decals and stick into place. The adhesive backing will bond on contact.

NOTE: *Please remember, safety signs provide important safety information for people working near bin unloading equipment that is in operation.*

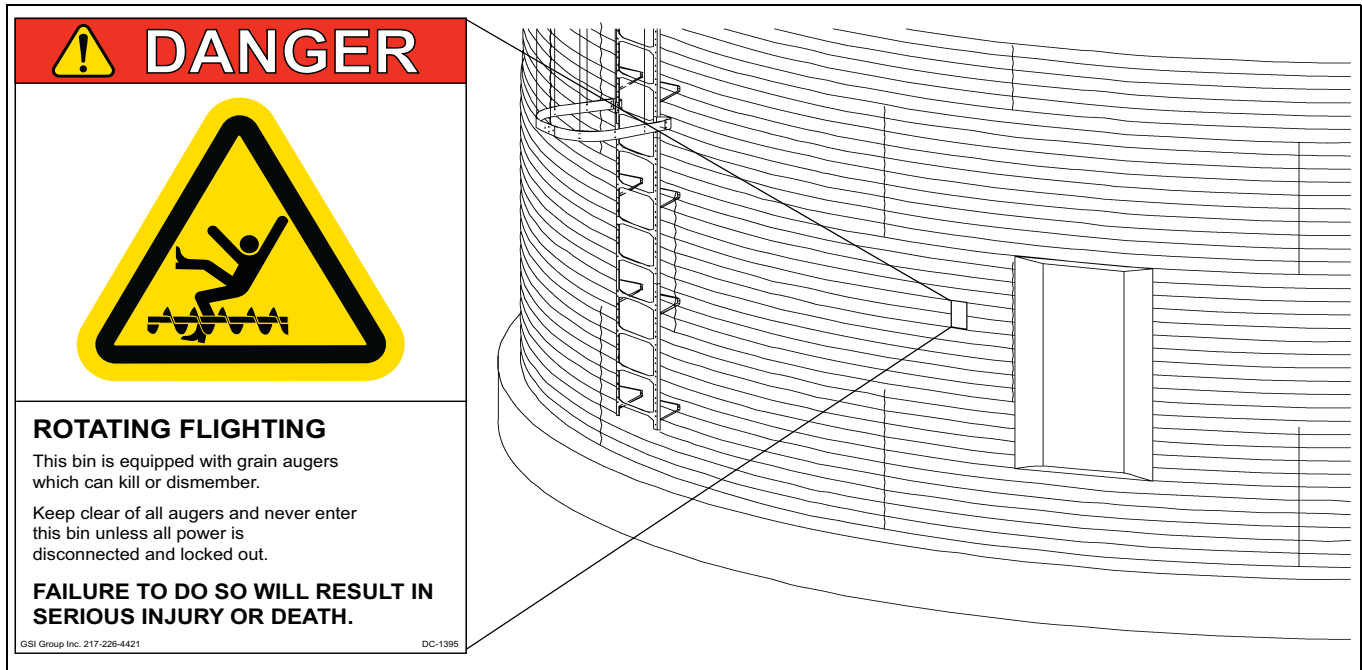

NOTE: *If the Safety Sign cannot be easily read for any reason or has been painted over, replace it immediately. Additional Safety Signs may be obtained free of charge from your dealer, distributor or ordered from the factory.*

Order SAFETY SIGN NO. DC-1395

The safety decals on your equipment are safety indicators which must be carefully read and understood by all personnel involved in the installation, operation, service and maintenance of the equipment.

To replace a damaged or missing decal, contact us to receive a free replacement.

GSI Decals

1004 E. Illinois St.
Assumption, IL. 62510
Phone: 1-217-226-4421

Location	Decal #	Decals	Description
On bin door covers	DC-GBC-1A		Danger Keep Clear of Augers

4. Assembly Instructions

Motor Mount Assembly Instructions

1. First, fill the chain reducer drive with oil by removing the vented fill plug and pouring 48 oz. of oil into drive. Oil level can be checked by removing the check plug. Oil should not be over the check plug. (See Figure 4A.)



Oil must be added before assembly. The chain reducer is shipped without oil.

Do NOT add more oil than recommended. Excess oil may damage the seals or be forced out through the vented fill plug.

For lubrication in normal operating temperature between 40°F to 120°F, we recommend the use of non-foaming, multi purpose gear oil, SAE 90 weight. For temperatures below 40°F, use a SAE 80 weight oil. Use grade commercially available for automotive differentials. Extra pressure additives may be of value in severe applications.

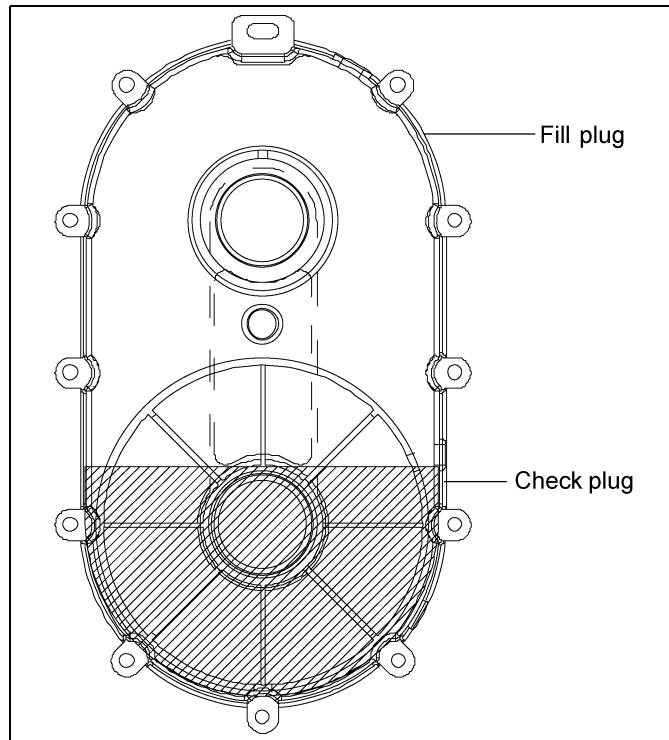

Figure 4A Enclosed Drive

2. Assemble the belt guard and mount frame, enclosed chain drive, sweep shield and drive frame and center pivot weldment together as shown in [Figure 4B on Page 15](#).
3. Slide motor mount rods through the belt guard back plate and into the tubes on the motor mount frame. Attach the top and bottom straps to the motor mount rods as shown in [Figure 4C on Page 16](#).
4. Install the electric motor on the motor mount straps.
5. Install the drive sheave onto the motor shaft using the 1/4" square key and tighten. (See [Page 26](#) for motor and pulley sizes.)
6. Install the belts and tighten them by adjusting the motor with the 7/8" nuts on the motor mount rods. Bolt the shield door closed with two (2) 5/16" x 3/4" cap screws and nylon lock nuts.

Motor Mount Assembly Instructions (Continued)

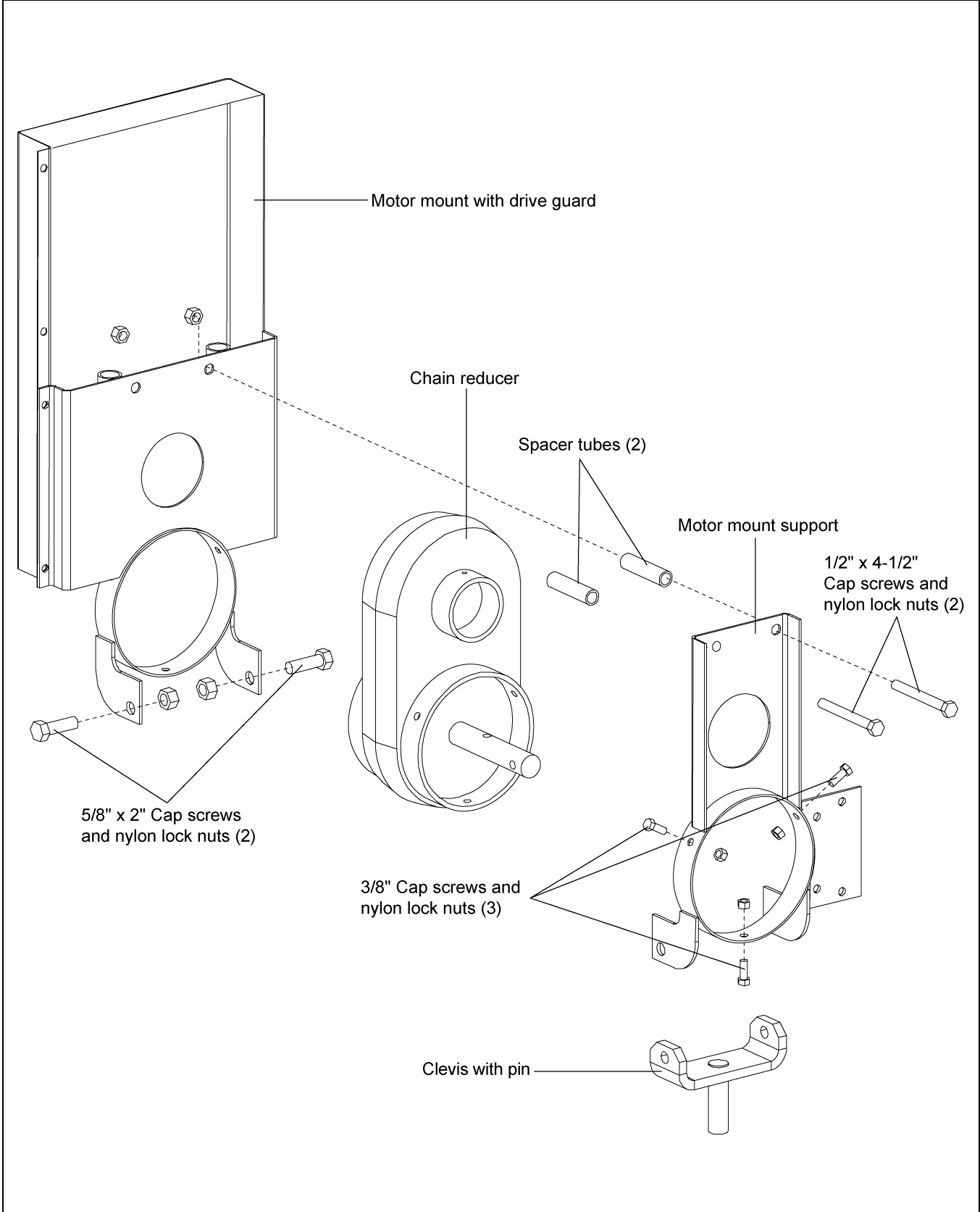

Figure 4B

Motor Mount Assembly Instructions (Continued)

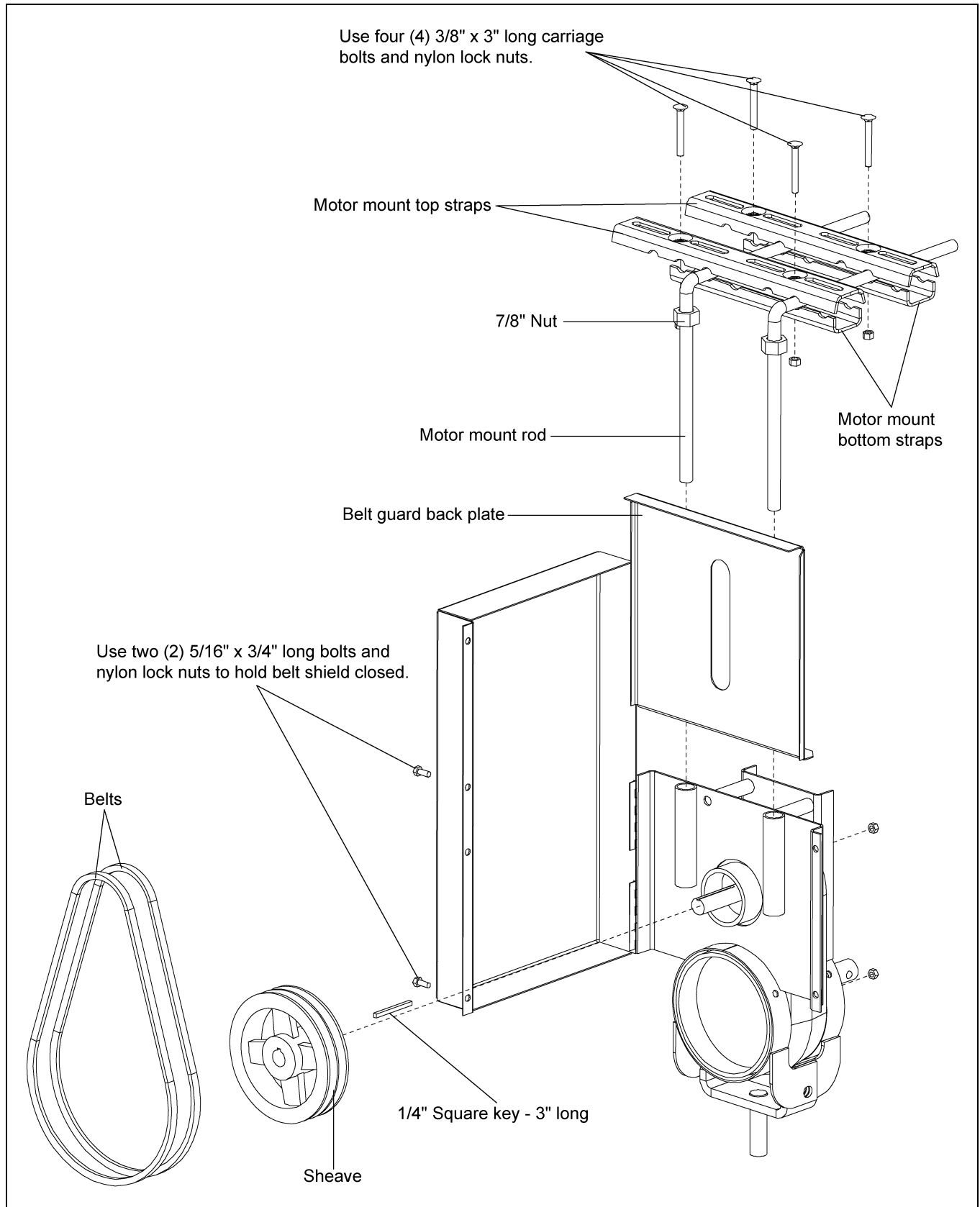

Figure 4C

Electrical Cord Support Stand Assembly

1. Install support stand onto the motor mount straps using two (2) 7/16" x 1-1/4" HHCS bolts, four (4) 7/16" flat washers and 7/16" nylock nuts. (See Figure 4D.)
2. Route the electrical cord from the motor through the support stand clamps. Leave a small loop of cord between clamps and motor. (See Figure 4D.)

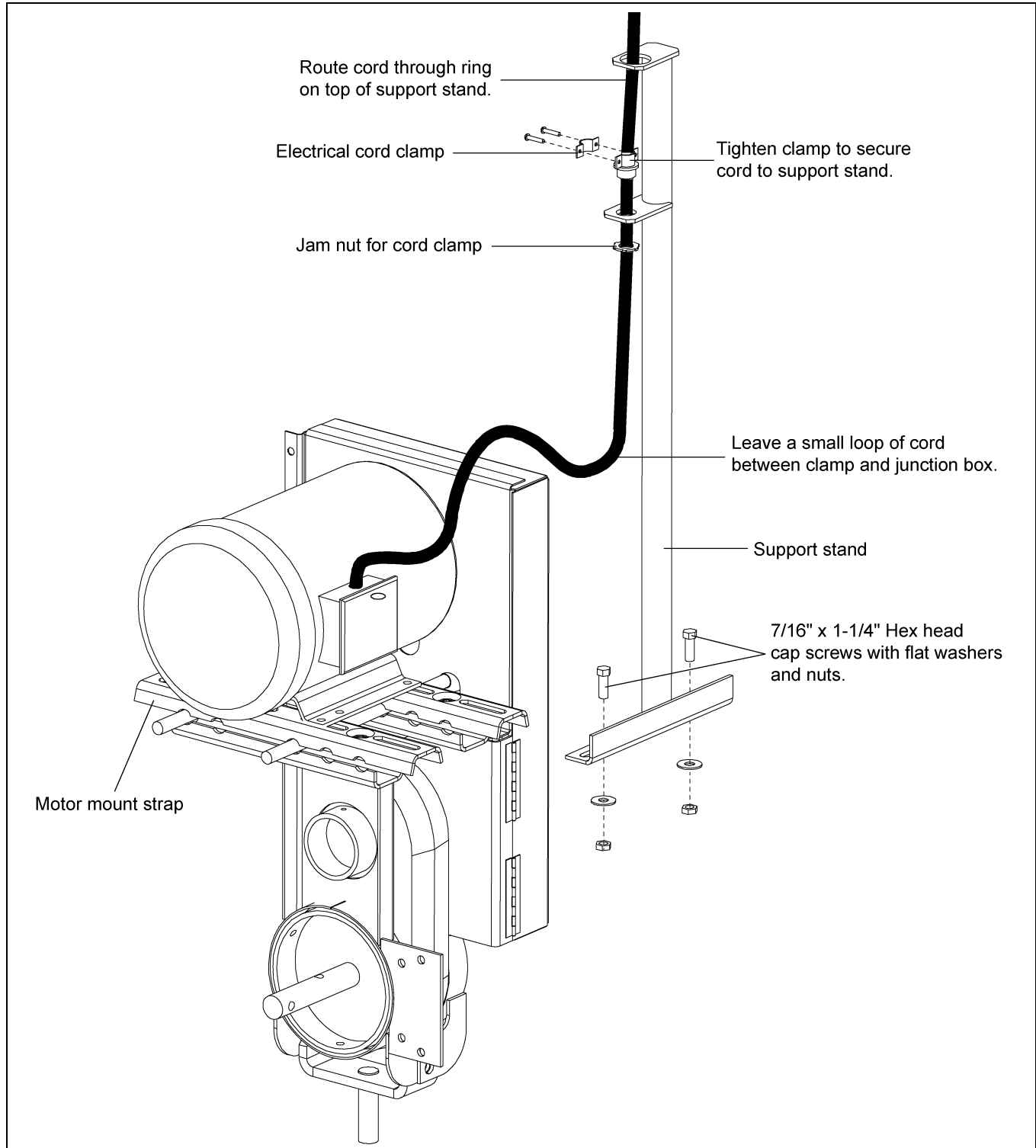

Figure 4D

4. Assembly Instructions

Assembling Sweep Flight and Back Shield Assembly

1. The number and lengths of sweep flighting and back shield sections will vary depending on the bin size. *See Chart* below for the flight and shield sections for the size bin.
2. The sweep flight with a cutback must connect to the drive assembly. The remaining sections should be assembled in the order shown in the *Chart below*.

The following instructions are for assembling a complete commercial sweep. If you have a large bin, it is recommended to use only part of the sweep auger when starting to sweep unload a bin. *Refer to Step 4 on Page 23* in this manual for more information.

Sweep Flight and Back Shield Sections

6" Catalog Number	8" Catalog Number	Bin Diameter	First Section w/ Cutback Attached to Drive Unit	Second Section from Drive Unit	Third Section from Drive Unit	Fourth Section from Drive Unit
GCS82400	GCS10240	24'	6' - 6-1/2"	3' - 9-1/2"		
GCS82700	GCS10270	27'	6' - 6-1/2"	5' - 3-1/2"		
GCS83000	GCS10300	30'	9' - 6-1/2"	3' - 9-1/2"		
GCS83300	GCS10330	33'	8'-1/2"	6' - 9-1/2"		
GCS83400	GCS10340	34'	6' - 6-1/2"	8'-10"		
GCS83600	GCS10360	36'	6' - 6-1/2"	9' - 9-1/2"		
GCS83700	GCS10370	37'	8'-1/2"	8'-10"		
GCS83900	GCS10390	39'	8'-1/2"	9' - 9-1/2"		
GCS84000	GCS10400	40'	9' - 6-1/2"	8'-10"		
GCS84200	GCS10420	42'	9' - 6-1/2"	9' - 9-1/2"		
GCS84800	GCS10480	48'	6' - 6-1/2"	5'-10"	9' - 9-1/2"	
GCS84900	GCS10490	49'	6' - 6-1/2"	9' - 3-1/2"	6' - 9-1/2"	
GCS85400	GCS10540	54'	9' - 6-1/2"	5'-10"	9' - 9-1/2"	
GCS85500	GCS10550	55'	8'-1/2"	9' - 3-1/2"	8' - 3-1/2"	
GCS86000	GCS10600	60'	9' - 6-1/2"	8'-10"	9' - 9-1/2"	
	GCS10630	63'	9' - 6-1/2"	5' - 3-1/2"	5'-10"	8'-10"
	GCS10680	68'	9' - 6-1/2"	5'-10"	6' - 9-1/2"	9' - 9-1/2"
	GCS10690	69'	8'-1/2"	5' - 3-1/2"	9' - 3-1/2"	9' - 9-1/2"
	GCS10720	72'	9' - 6-1/2"	5'-10"	8'-10"	9' - 9-1/2"
	GCS10750	75'	8'-1/2"	8'-10"	8'-10"	9' - 9-1/2"
	GCS10780	78'	9' - 6-1/2"	9' - 9-1/2"	8'-10"	8'-10"
	GCS10800	80'	9' - 6-1/2"	9' - 9-1/2"	9' - 9-1/2"	8'-10"
	GCS10820	82'	9' - 6-1/2"	9' - 9-1/2"	9' - 9-1/2"	9' - 9-1/2"

Assembling Sweep Flight and Back Shield Assembly (Continued)

Sweep Flight and Back Shield Sections for Bins with Double Frame Door

8" Catalog Number	Bin Diameter	First Section w/ Cutback Attached to Drive Unit	Second Section from Drive Unit	Third Section from Drive Unit	Fourth Section from Drive Unit
GCS10420DF	42'	9' - 6-1/2"	9'-2"		
GCS10480DF	48'	9' - 6-1/2"	3' - 9-1/2"	8'-2"	
GCS10540DF	54'	9' - 6-1/2"	5'-10"	9'-2"	
GCS10600DF	60'	9' - 6-1/2"	9'-1"	8'-10"	
GCS10720DF	72'	9' - 6-1/2"	5'-10"	8'-6"	9' - 3-1/2"

- Bolt the sweep flight with the cutback to the reducer output shaft of the drive assembly using two (2) 7/16" x 2-1/2" HHCS bolts and lock nut. Attach the back shield to the drive frame using two (2) 3/8" x 1-1/4" carriage bolt, flat washers and nylon lock nuts. (See Figure 4E.)
- Connect the sweep flights together with the connecting stub shaft using four (4) 7/16" x 2-1/2" HHCS bolts and lock nuts. Be sure to place connecting stub shaft through the bearing bracket before attaching the flight together. (See Figure 4E.)
- Attach the back shields to the bearing bracket using two (2) 3/8" x 3" carriage bolts with flat washers and lock nuts. Connect the splice plate to the shields with four (4) 5/16" x 3/4" HHCS bolts and lock nuts. For bins 48' or larger in diameter, install the sweep carrier at a bearing location in the center or outward of center of sweep length. (See Figure 4E.)

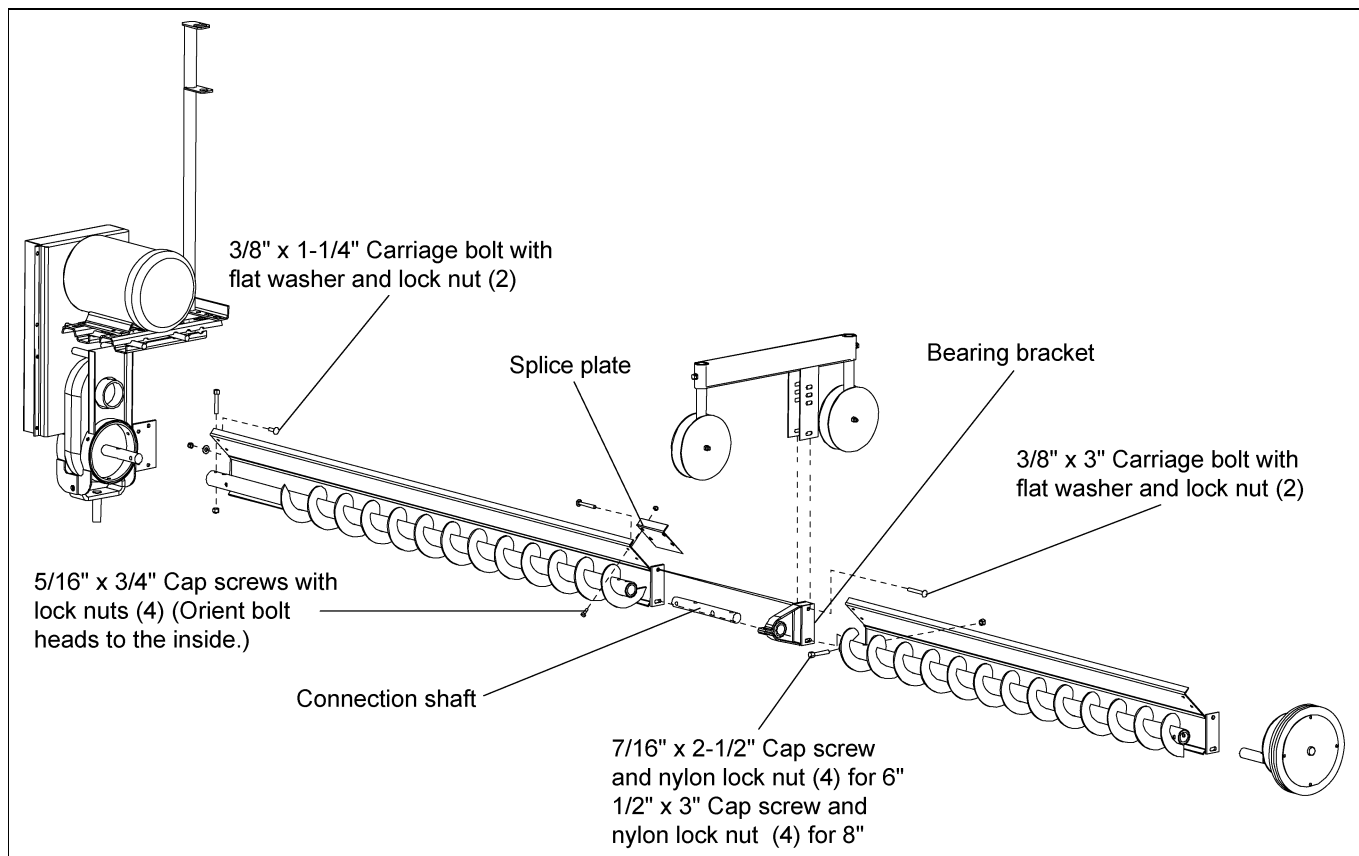

Figure 4E

4. Assembly Instructions

Sweep Wheel Installation

1. Insert the input shaft of the reduction drive into the open end of the flight. Attach the drive to the flight with one $7/16"$ x 3" grade 8 bolt and stover nut for 6" or one $1/2"$ x 3" grade 8 bolt and stover nut for 8" and 10". (See Figure 4F.)
2. Mount the reducer to the back shield with two (2) $3/8"$ x $1-1/4"$ serrated flange bolts, one flat washer and nylock nut.
3. Attach the wheel hub welded assembly to the reduction drive with one $3/8"$ x $2-1/2"$ grade 8 bolt and stover nut.
4. Attach the rubber discs and outer wheel disc to the wheel hub welded assembly with four (4) $5/16"$ x 2" grade 2 bolts and nylock nuts. (See Figure 4F.)

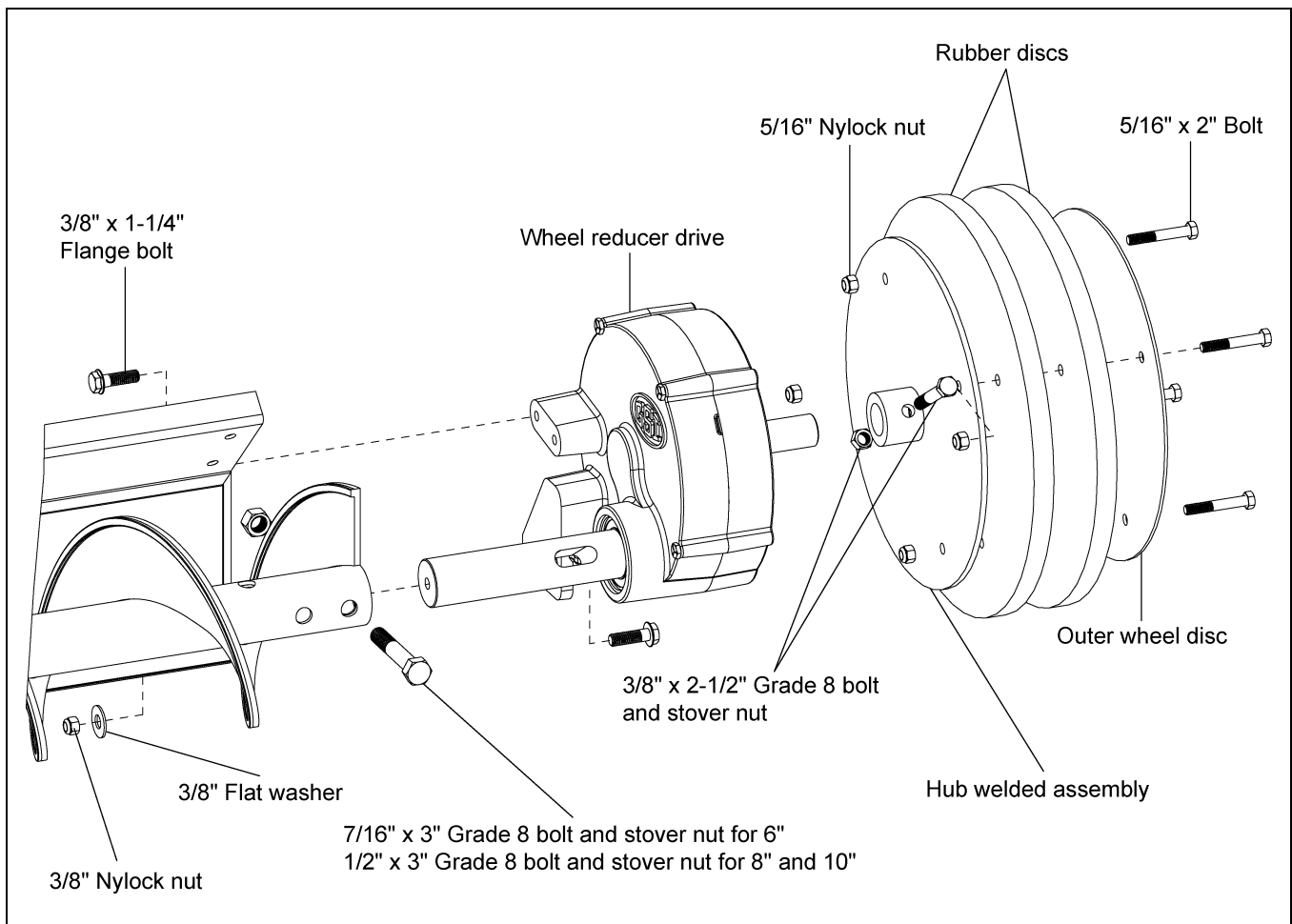

Figure 4F

Installation Procedures

1. Shut down and lock out the unloading unit before entering the bin.
 - a. If the bin is not equipped with intermediate wells, the Commercial Sweep Auger may be placed in the bin after all the grain has been removed that will gravity flow through the center well.
 - b. The grain remaining should appear as in [Figure 5C on Page 22](#). **DO NOT** enter a bin if the grain has bridged or flowed abnormally out of the bin as shown in [Figure 5A](#) or [Figure 5B on Page 22](#). Suffocation can occur if grain suddenly breaks loose, burying persons who are inside the bin.



DANGER

 <p>Rotating flighting will kill or dismember.</p>	 <p>Flowing material will trap and suffocate.</p>	 <p>Crusted material will collapse and suffocate.</p>
---	--	--

Keep clear of all augers. DO NOT ENTER this bin!

If you must enter the bin:

1. Shut off and lock out all power.
2. Use a safety harness and safety line.
3. Station another person outside the bin.
4. Avoid the center of the bin.
5. Wear proper breathing equipment or respirator.

Failure to heed these warnings will result in serious injury or death.

GSI GROUP, INC. 217-226-4421
DC-GBC-1A

5. Installation

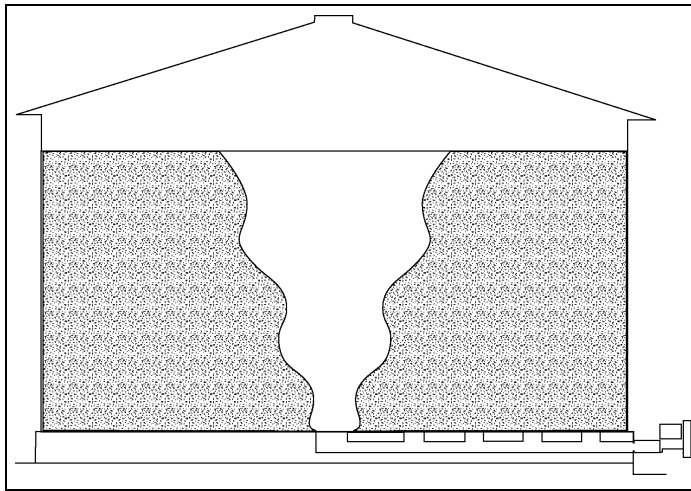

Abnormal grain flow can easily fall and bury a person, suffocating them. **DO NOT** enter a bin with abnormal grain flow.

Figure 5A

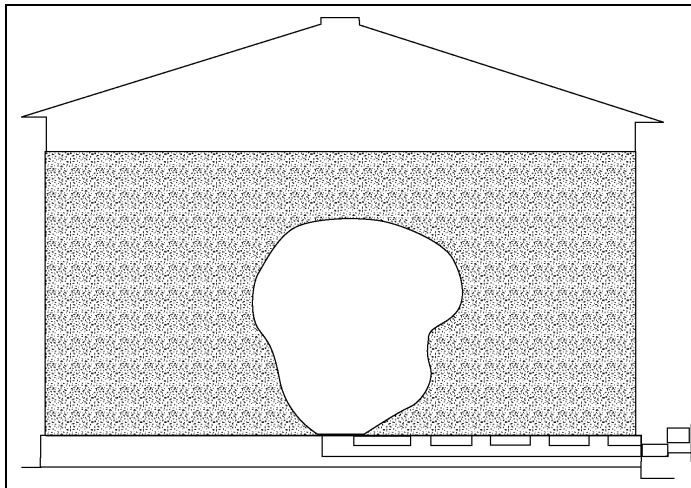

Bridged grain can easily break loose and bury a person, suffocating them. **DO NOT** enter a bin with bridged grain.

Figure 5B

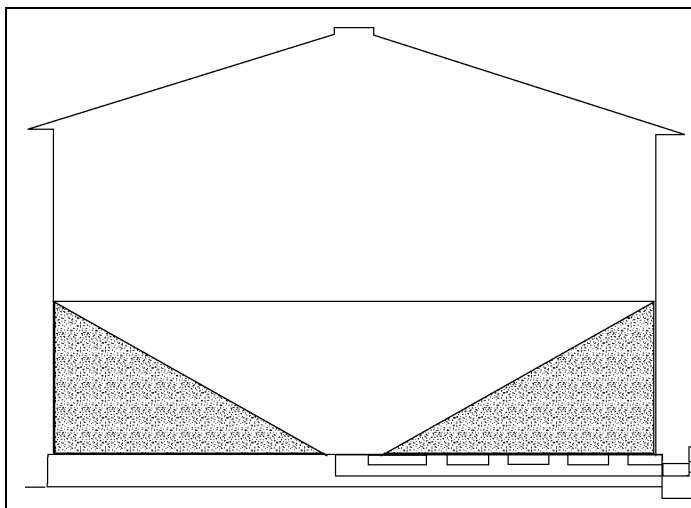

Grain should look similar to this. Always shut down and lock out the power to all devices before entering a bin.

Figure 5C

2. If the bin is equipped with intermediate bin wells, open them after grain has stopped flowing into the center well and before the sweep auger is placed in the bin. Open the intermediate wells near the bin center first. Then when grain flow stops, open the wells near the bin wall. (See Figure 5D.) The Commercial Sweep Auger can then be installed. Always shut down the unloading equipment and lock out power before entering the bin.
3. Place the sweep motor mount pivot pin into the pivot tube of the center well. Lay the sweep auger assembly on the pile of sloping grain or in the area of the intermediate wells where additional grain has been removed.

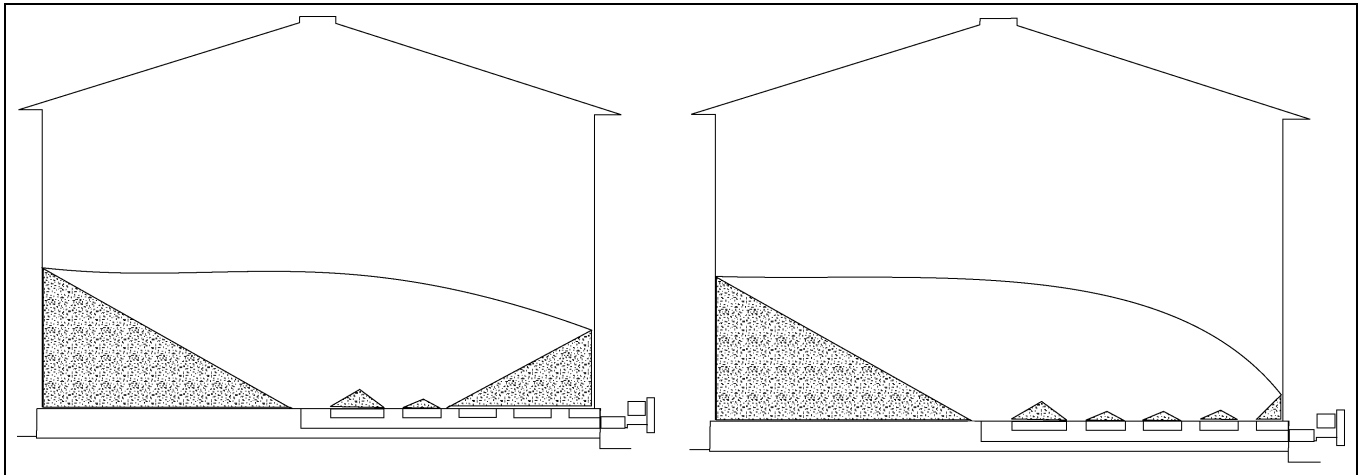

Figure 5D



Keep out of bin while sweep is in operation. Rapidly traveling sweep auger.

4. The Commercial Sweep Augers are made with the sweep auger and back shield in two (2) or more sections. One of the sections can be used first alone by attaching the section to the drive unit and mounting the reduction wheel on that section. Then, after the center portion of the bin has been emptied, another section of sweep auger and back shield may be added and the unloading process continued. (See Figure 5E.) If the sweep is equipped with a truss, be sure to tie-off extra cable length so it does not become entangled in the sweep auger. Always shut down the unloading equipment and lock out power before entering the bin.

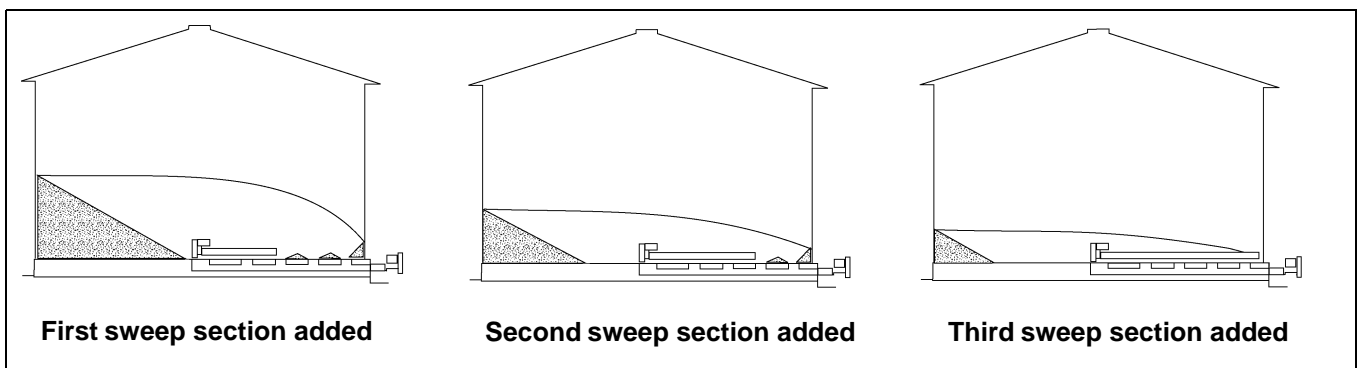

Figure 5E

5. Installation

- a. Using the gradual method of unloading described above helps to avoid situations where cascading grain can bury the sweep causing high torque loads and possible damage to the sweep assembly. This kind of damage is not covered by the warranty.
 - b. This type of operation may also be used to prevent the unloading of one side of the bin totally before any grain is removed from the other side. Total unloading of one side of large diameter bins without some unloading from the other side can cause structural damage to the bin. Check with the grain bin dealer or the bin manufacturer for bin unloading recommendations.
5. Attach suitable electric wiring to the motor in a manner that will permit the sweep to rotate several times about the bin. The motor starting controls must be located outside of the bin. They must never be installed on the sweep auger inside the bin. Locate the motor starting controls outside the bin, but near the door so the operator has full view of the operation inside the bin. (See Figure 5F.)

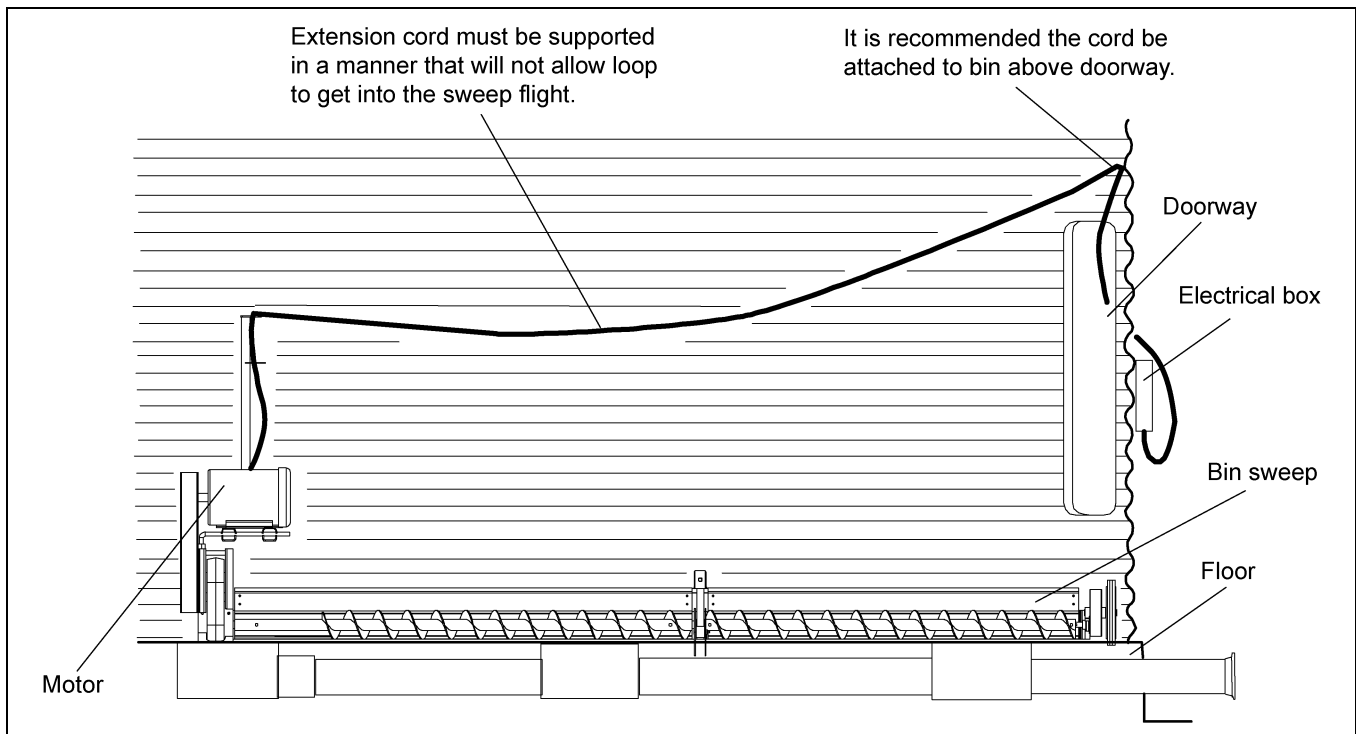

Figure 5F



NEVER enter the bin while the sweep auger is in operation. Never attempt to control the operation of the sweep auger by pushing on the operating sweep auger with shovels, brooms or other devices. DO NOT attempt to restrain movement of the sweep auger by attaching ropes, bars or other devices to be held by an operator.

6. Start the under floor bin unloading equipment before starting the Commercial Sweep Auger. The sweep auger will work towards the floor at approximately a 45° angle and then empty the bin or center area of the bin in one revolution after reaching the floor. As soon as the bin or center area of the bin empties, the sweep auger will rotate rapidly around the bin. Shut down the sweep auger as soon as the bin or center area of the bin is empty.

The height of the Commercial Sweep back shield above the bin floor can be adjusted at the motor mount and at the bolted connection between back shields. The back shield must be adjusted to clear the floor at least 1" to permit the reduction sweep wheel to propel the sweep properly into the grain. Be sure back shields will clear splices in metal flooring or cracks in concrete floors.

Final Clean Out

The following procedure is recommended for cleaning the floor of the bin after the sweep auger has removed as much grain as possible.

1. Clean (scoop and sweep by hand) the outer area of the floor into a circular pile towards the center of the bin. (See Figure 5G.)
2. Get out of the bin.
3. After making sure everyone is outside the bin and clear of the equipment, start the under floor unloader and the sweep auger. In a short time, the circular pile towards the center of the bin will have been removed.
4. Stop the equipment and lock out power.
5. Scoop and sweep by hand the remaining floor area to the center of the bin. (See Figure 5G.)
6. Get out of the bin.
7. Repeat [Step 3](#), [Step 4](#), [Step 5](#) and [Step 6](#) until all grain has been removed from the bin.

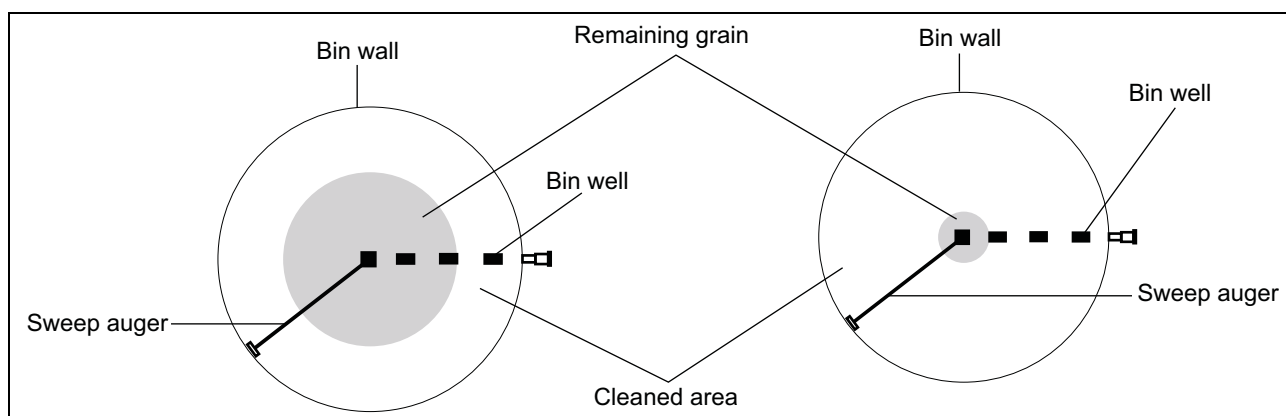

Figure 5G Top View of Bin



DO NOT enter a grain bin unless all power driven equipment has been shut down and locked out.



Keep out of bin while sweep is in operation. Rapidly traveling sweep auger. The sweep auger will move rapidly around the bin when the bin is nearly empty.



Stay clear of the under floor unloader at the bin wells. The under floor unloader is exposed at these locations in the bin floor.



DO NOT STORE SWEEPS IN THE BIN.

Sweeps are NOT designed to remain in a bin during filling, storage or bottom (gravity) unloading. A sweep left in a bin during these operations may be severely damaged. The GSI Group will not be responsible for such damages.

The following action may reduce damages to a sweep remaining in a bin: Lifting the sweep off the center pivot, positioning it parallel to the intermediate wells (along side of - not on top of) and fully supporting the sweep to the bin floor. However, even with this procedure, the GSI Group will not be responsible for any damages to the sweep.

6. Operating Procedures

Power Source

The horsepower recommendations are for augering reasonably dry grain. High moisture grain (above 15%) will require greater power if maximum capacity is to be maintained. The maximum possible capacity will be less with high moisture grain than with dry grain.



A main power disconnect switch capable of being locked only in the OFF position should be used. The switch should be locked out whenever work is being done on the power sweep.



- 1. Electric motors and controls must be installed by a qualified electrician and must meet the standards set by the National Electrical Code and all local and state codes.**
- 2. A magnetic starter should be used to protect the motor when starting and stopping. It should stop the motor in case of power interruption, conductor fault, low voltage, circuit interruption or motor overload. Then the motor must be restarted manually. Some motors have built-in thermal overload protection. If this type motor is used, use only those with a manual reset.**
- 3. The motor starting controls must be located outside the bin. They must never be installed on the sweep auger inside the bin. Locate the motor starting controls outside the bin, but near the bin door so the operator has full view of the operation inside the bin.**
- 4. Disconnect power before resetting motor overloads.**
- 5. Reset and motor starting controls must be located so that the operator has full view of the entire operation.**
- 6. Make certain all electric motors are grounded.**
- 7. Shut off power to adjust, service or clean.**

Use the tables [below](#) to determine the horsepower and electric motor pulley size the specific sweep requires. Use an electric motor that operates at 1750 RPM (motor pulley not furnished).

Horsepower Requirements for 6" Commercial Power Sweep with 6" Bin Unloader				Horsepower Requirements for 6" Commercial Power Sweep with 8" Bin Unloader		
Bin Diameter	24'-37'	39'-60'	63'-75'	24'-30'	33'-48'	49'-75'
HP (Electric)	2 HP	3 HP	5 HP	2 HP	3 HP	5 HP
Motor Pulley	3.0" O.D.	3.0" O.D.	3.0" O.D.	4.0" O.D.	4.0" O.D.	4.0" O.D.
Operating Flight Speed	328 RPM	328 RPM	328 RPM	438 RPM	438 RPM	438 RPM
O.D. = Outside Diameter of Sheave				O.D. = Pitch Diameter of Sheave		

Horsepower Requirements for 8" Commercial Bin Sweep with 8" Bin Unloader				Horsepower Requirements for 8" Commercial Bin Sweep with 10" Bin Unloader		
Bin Diameter	24'-42'	48'-72'	75'-92'	24'-36'	37'-60'	63'-92'
HP (Electric)	3 HP	5 HP	7.5 HP	3 HP	5 HP	7.5 HP
Motor Pulley	3-1/2" O.D.	3-1/2" O.D.	3-1/2" O.D.	4-1/2" O.D.	4-1/2" O.D.	4-1/2" O.D.
Operating Flight Speed	306 RPM	306 RPM	306 RPM	394 RPM	394 RPM	394 RPM
O.D. = Outside Diameter of Sheave				O.D. = Outside Diameter of Sheave		

Belt Tension

Check the belt tension on electric drive. To tighten belt, use the two (2) adjusting nuts on the rod assemblies. **DO NOT** over tighten belts.

Enclosed Drive Lubrication

1. The enclosed drive is located at the discharge end of the auger housing and is shipped without oil. Oil is to be added to the unit during field assembly of the auger. Oil will dissipate under normal operating conditions, therefore the oil level should be checked regularly. Add 90 EP (non-foaming) oil until the oil level reaches the check point.
2. For lubrication in normal operating temperature between 40°F to 120°F, we recommend the use of non-foaming, multi purpose gear oil. Use SAE 90 weight for normal operating temperatures. For temperatures below 40°F, use SAE 80 weight oil. Use a grade of oil commercially available for automotive differentials. Extra pressure additives may be of value in severe applications.

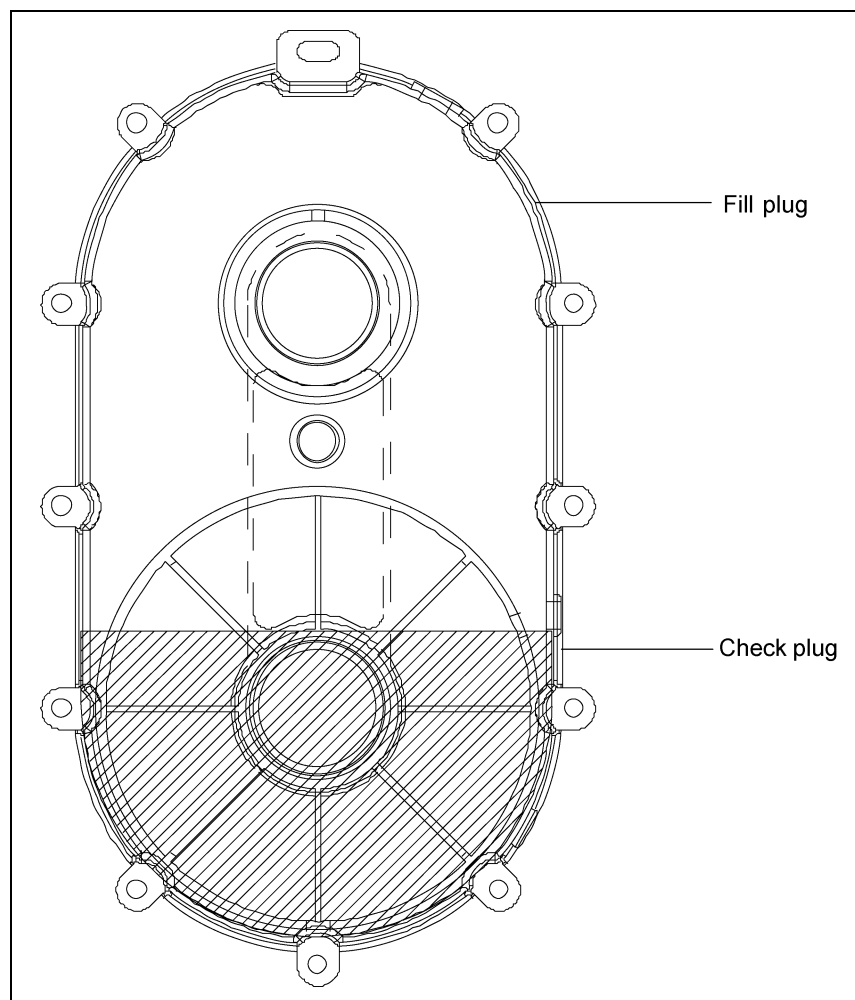

Figure 7A Enclosed Drive



DO NOT add more oil than recommended. Excess oil may damage the seals or be forced out through the vented plug.

Reduction Sweep Wheel

Add two (2) ounces of multi purpose gun grease to the sweep wheel drive enclosure during assembly and each time the bin has been emptied. Use the grease zerk on the drive housing.

Troubleshooting

1. Low Capacity

Sweep capacity may vary as the angle of sloping grain varies. Check the horsepower requirements [on Page 26](#), to determine correct operating speed and the motor pulley size recommended for that speed. If a greater or lower capacity is desired it may be possible to change the motor pulley which will change the sweep flight speed. Do not attempt operation at speeds greater than 50 RPM to 100 RPM above standard recommended speed. Do not operate a sweep that is overfeeding the unloading auger unit. The slide gate in the center well should be left full open during sweep operation.

2. Sweep Flight and Back Shield not Moving

DO NOT STORE SWEEPS IN THE BIN.

Sweeps are NOT designed to remain in a bin during filling, storage or bottom (gravity) unloading. A sweep left in a bin during these operations may be severely damaged. The GSI Group will not be responsible for such damages.

The following action may reduce damages to a sweep remaining in a bin: Lifting the sweep off the center pivot, positioning it parallel to the intermediate wells (along side of - not on top of) and fully supporting the sweep to the bin floor. However, even with this procedure, the GSI Group will not be responsible for any damages to the sweep.

Check clearance between back shield and the bin floor for excessive drag. It may be possible to adjust the back shield up by working the slotted connections between back shields at bearing brackets.

The grain may have gone out of condition due to moisture or insect activity and has become hard or caked. Stop the sweep auger and lock out power before entering the bin to correct this or any other difficulty. Make sure the grain has not flowed abnormally or bridged over. [See Page 22](#) for illustrations.

1. 6" and 8" Commercial Bin Sweep Flight and Shields - [\(See Page 30.\)](#)
2. Carrier Wheel Assembly - [\(See Page 31.\)](#)
3. 6", 8" and 10" Commercial Bin Sweep Parts - [\(See Pages 32-35.\)](#)
4. 2 to 1 Enclosed Chain Drive - [\(See Pages 36-37.\)](#)

8. Parts List

6" and 8" Commercial Bin Sweep Flight and Shields

6" Flight and Shield Bundles Parts List

Bundle #	Part #	Description
GK5014	-	-
	GK4534	6' - 6-1/2" Shield
	GK4665	6' - 6-1/2" Flight w/ Cutback
GK5015	-	-
	GK4536	9' - 6-1/2" Shield
	GK4667	9' - 6-1/2" Flight w/ Cutback
GK5016	-	-
	GK4535	8'-1/2" Shield
	GK4666	8'-1/2" Flight w/ Cutback
GK5017	-	-
	GK4537	5'-10" Shield
	GK2134	5'-10" Flight
GK5018	-	-
	GK4538	8'-10" Shield
	GK2129	8'-10" Flight
GK5019	-	-
	GK2116	3' - 9-1/2" Shield
	GK2117	3' - 9-1/2" Flight
GK5020	-	-
	GK2119	5' - 3-1/2" Shield
	GK2120	5' - 3-1/2" Flight
GK5021	-	-
	GK2114	6' - 9-1/2" Shield
	GK2115	6' - 9-1/2" Flight
GK5022	-	-
	GK2136	9' - 3-1/2" Shield
	GK2137	9' - 3-1/2" Flight
GK5023	-	-
	GK2122	9' - 9-1/2" Shield
	GK2123	9' - 9-1/2" Flight
GK5024	-	-
	GK2125	8' - 3-1/2" Shield
	GK2126	8' - 3-1/2" Flight

8" Flight and Shield Bundles Parts List

Bundle #	Part #	Description
GK4824	-	-
	GK4741	6' - 6-1/2" Shield
	GK4718	6' - 6-1/2" Flight w/ Cutback
GK4825	-	-
	GK4747	9' - 6-1/2" Shield
	GK4720	9' - 6-1/2" Flight w/ Cutback
GK4826	-	-
	GK4743	8'-1/2" Shield
	GK4719	8'-1/2" Flight w/ Cutback
GK4827	-	-
	GK4740	5'-10" Shield
	GK2080	5'-10" Flight
GK4828	-	-
	GK4745	8'-10" Shield
	GK2074	8'-10" Flight
GK4829	-	-
	GK4738	3' - 9-1/2" Shield
	GK1956	3' - 9-1/2" Flight
GK4830	-	-
	GK4739	5' - 3-1/2" Shield
	GK1961	5' - 3-1/2" Flight
GK4831	-	-
	GK4742	6' - 9-1/2" Shield
	GK1958	6' - 9-1/2" Flight
GK4832	-	-
	GK4746	9' - 3-1/2" Shield
	GK2088	9' - 3-1/2" Flight
GK4833	-	-
	GK4748	9' - 9-1/2" Shield
	GK1964	9' - 9-1/2" Flight
GK4834	-	-
	GK4744	8' - 3-1/2" Shield
	GK1967	8' - 3-1/2" Flight
GK80232	-	-
	GK80234	6'-2" Shield
	GK80233	6'-1/2" Flight
GK80241	-	-
	GK80243	8'-2" Shield
	GK80242	8'-1/2" Flight
GK80244	-	-
	GK80246	9'-1" Shield
	GK80245	9'-1/2" Flight
GK80247	-	-
	GK80249	9'-2" Shield
	GK80248	9'-1/2" Flight

Carrier Wheel Assembly

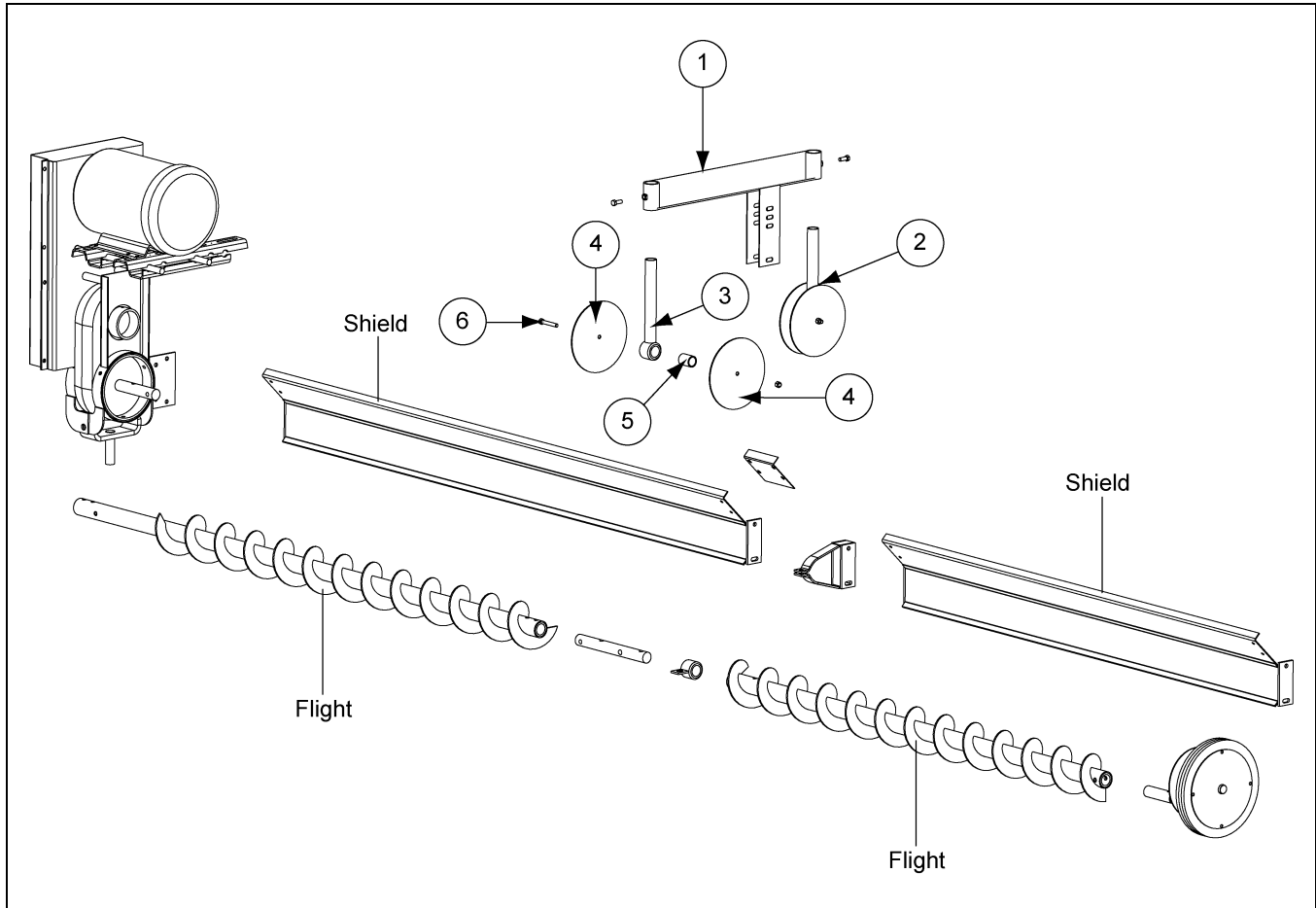

Carrier Wheel Assembly Parts List

Ref #	Part #	Description
1	GK2082-BS	Body Weldment - Bin Silver
2	GK2083	Spindle and Wheel Assembly
3	GK2084	Spindle Weldment
4	GK2085	Wheel Disc 10 Gauge Black 8-1/8" O.D.
5	GK2086	Spindle Bushing, 1-1/4" O.D. x 1-5/8" Long
6	S-6762	Bolt, HHCS 3/8"-16 x 2-1/2" ZN Grade 5

8. Parts List

6", 8" and 10" Commercial Bin Sweep Parts

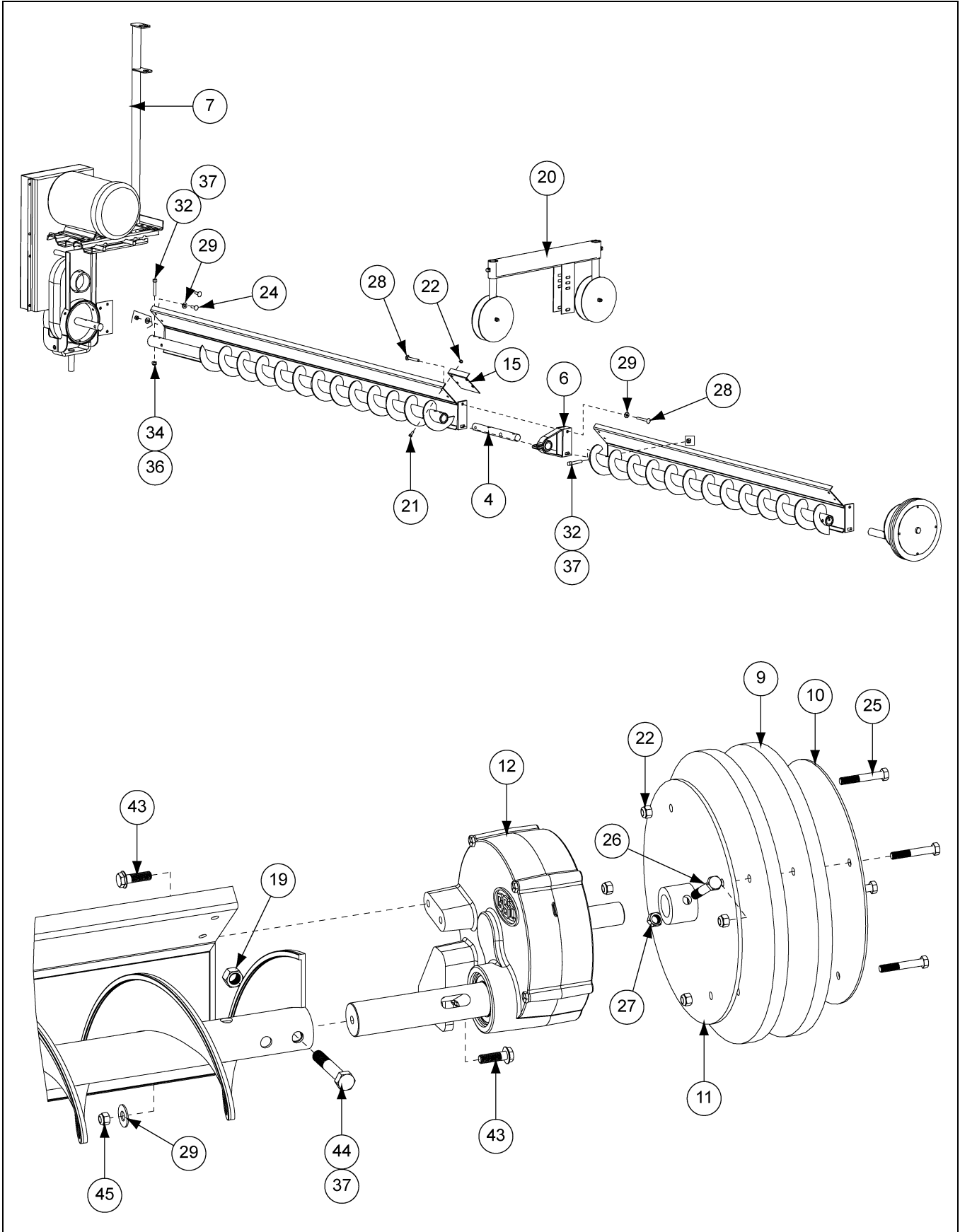

6" and 8" Commercial Sweep for 24'-60' Bins Parts List

Ref #	Part #	Description	Ref #	Part #	Description
1	GK5361	Motor Mount Rod	19	S-8315	1/2"-13 Stover Nut Zinc Grade C - 8"
2	GK1341-BS	Motor Mount Bottom Strap - Bin Silver	20	GK2078	Carrier Wheel Assembly
3	GK1342-BS	Motor Mount Top Strap - Bin Silver	21	S-8072	Bolt, HHCS 5/16"-18 x 3/4" ZN Grade 2
4	GK1736	Shaft Connector 1-1/4" O.D. x 11-1/2" - 6"	22	S-7382	Nylock Nut 5/16"-18 ZN Grade 5
4	GK1951	Shaft Connector 1-1/2" O.D. x 11-1/2" - 8"	23	S-7469	Bolt, HHCS 3/8"-16 x 1" ZN Grade 5
5	GK1952	V-Belt B50 - 6"	24	S-8231	3/8"-16 x 1-1/4" Zinc Grade 5 Carriage Bolt
5	GK2349	V-Belt B54 - 8"	25	S-7329	Bolt, HHCS 5/16"-18 x 2" ZN Grade 2
6	GK2107	Shield Bearing Bracket - 6"	26	S-10107	Bolt, HHCS 3/8"-16 x 2-1/2" ZN Grade 8
6	GK1954	SB 10" Bearing Stand Assembly - 8"	27	S-8251	Stover Nut 3/8"-16 ZN Grade C
7	GK4203-BS	Electric Cord Support Stand - Bin Silver	28	S-8055	Carriage Bolt 3/8"-16 x 3" ZN Grade 5
8	GK4204	Sweep Shield and Drive Frame	29	S-248	Flat Washer 3/8" 7/16" I.D. 1" O.D. YDP
9	GK4218	Wheel Disc, Rubber, 11" - 6"	30	S-7383	Nylock Nut 3/8"-16 ZN Grade 5
9	GK4241	Wheel Disc, Rubber, 13" - 8"	31	S-3886	Bolt, HHCS 7/16"-14 x 1-1/4" ZN Grade 5
10	GK4219	Outer Wheel Disc - 6"	32	S-7013	Bolt, HHCS 7/16"-14 x 2-1/2" ZN Grade 5
10	GK4240	Outer Wheel Disc - 8" and 10"	33	S-8320	Flat Washer 7/16" USS ZN
11	GK80071-BS	Wheel Hub Welded Assembly - Bin Silver - 6"	34	S-8234	Nylock Nut 7/16"-14 ZN Grade 2
11	GK80072-BS	Wheel Hub Welded Assembly - Bin Silver - 8"	35	S-8232	Bolt, HHCS 1/2"-13 x 4-1/2" ZN Grade 5
12	GK80023	Reduction Wheel Drive, 7.889:1, Gear - 6"	36	S-8260	Nylock Nut 1/2"-13 ZN Grade 5
12	GK7960	Reduction Wheel Drive, 7.889:1, Gear - 8"	37	S-8252	Bolt, HHCS 1/2"-13 x 3" YDP Grade 8
13	GK4220	Belt Guard and Motor Mount Frame	38	S-4329	Bolt, HHCS 5/8"-11 x 2" YDP Grade 8 or 8.2
14	GK4222-BS	Center Pivot Weldment - Bin Silver	39	S-8349	Nylock Nut 5/8"-11 ZN Grade 2
15	GK4229	Splice Plate for Shield	40	S-3214	Hex Nut 7/8"-9 YDP Grade 2
16	GK4250	Belt Guard Spacer Pipe	41	S-8276	Long Square Key 1/4" x 1/4" x 3"
17	GK4840	Enclosed Chain Drive (2 to 1) - 6"	42	GK5610	Back Plate Assembly
17	GK4841	Enclosed Chain Drive (2 to 1) - 8"	43	S-9066	Flange Bolt 3/8"-16 x 1-1/4" ZN Grade 5
18	GK4842	8" x 1" Bore 2 Belt Aluminum Sheave	44	S-8316	Bolt, HHCS 7/16"-14 x 3" ZN Grade 8
18	GK1983	10" x 1" Bore 2 Belt Aluminum Sheave	45	S-7383	3/8" Nylock Nut ZN Grade 5
19	S-8317	7/16"-14 Stover Nut Zinc Grade C - 6"			

8. Parts List

6", 8" and 10" Commercial Bin Sweep Parts (Continued)

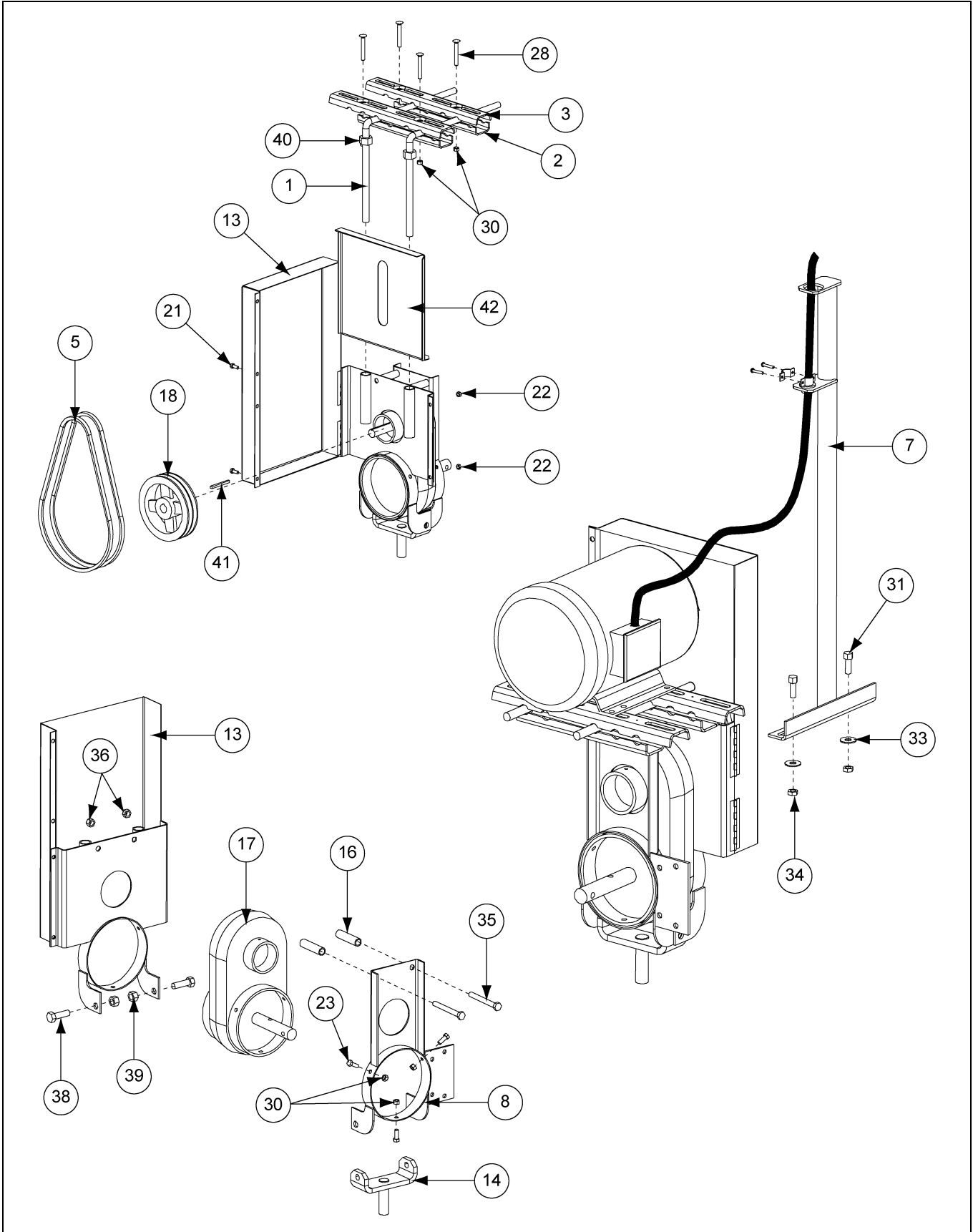

6" and 8" Commercial Sweep for 24'-60' Bins Parts List

Ref #	Part #	Description	Ref #	Part #	Description
1	GK5361	Motor Mount Rod	19	S-8315	1/2"-13 Stover Nut Zinc Grade C - 8"
2	GK1341-BS	Motor Mount Bottom Strap - Bin Silver	20	GK2078	Carrier Wheel Assembly
3	GK1342-BS	Motor Mount Top Strap - Bin Silver	21	S-8072	Bolt, HHCS 5/16"-18 x 3/4" ZN Grade 2
4	GK1736	Shaft Connector 1-1/4" O.D. x 11-1/2" - 6"	22	S-7382	Nylock Nut 5/16"-18 ZN Grade 5
4	GK1951	Shaft Connector 1-1/2" O.D. x 11-1/2" - 8"	23	S-7469	Bolt, HHCS 3/8"-16 x 1" ZN Grade 5
5	GK1952	V-Belt B50 - 6"	24	S-8231	3/8"-16 x 1-1/4" Zinc Grade 5 Carriage Bolt
5	GK2349	V-Belt B54 - 8"	25	S-7329	Bolt, HHCS 5/16"-18 x 2" ZN Grade 2
6	GK2107	Shield Bearing Bracket - 6"	26	S-10107	Bolt, HHCS 3/8"-16 x 2-1/2" ZN Grade 8
6	GK1954	SB 10" Bearing Stand Assembly - 8"	27	S-8251	Stover Nut 3/8"-16 ZN Grade C
7	GK4203-BS	Electric Cord Support Stand - Bin Silver	28	S-8055	Carriage Bolt 3/8"-16 x 3" ZN Grade 5
8	GK4204	Sweep Shield and Drive Frame	29	S-248	Flat Washer 3/8" 7/16" I.D. 1" O.D. YDP
9	GK4218	Wheel Disc, Rubber, 11" - 6"	30	S-7383	Nylock Nut 3/8"-16 ZN Grade 5
9	GK4241	Wheel Disc, Rubber, 13" - 8"	31	S-3886	Bolt, HHCS 7/16"-14 x 1-1/4" ZN Grade 5
10	GK4219	Outer Wheel Disc - 6"	32	S-7013	Bolt, HHCS 7/16"-14 x 2-1/2" ZN Grade 5
10	GK4240	Outer Wheel Disc - 8" and 10"	33	S-8320	Flat Washer 7/16" USS ZN
11	GK80071-BS	Wheel Hub Welded Assembly - Bin Silver - 6"	34	S-8234	Nylock Nut 7/16"-14 ZN Grade 2
11	GK80072-BS	Wheel Hub Welded Assembly - Bin Silver - 8"	35	S-8232	Bolt, HHCS 1/2"-13 x 4-1/2" ZN Grade 5
12	GK80023	Reduction Wheel Drive, 7.889:1, Gear - 6"	36	S-8260	Nylock Nut 1/2"-13 ZN Grade 5
12	GK7960	Reduction Wheel Drive, 7.889:1, Gear - 8"	37	S-8252	Bolt, HHCS 1/2"-13 x 3" YDP Grade 8
13	GK4220	Belt Guard and Motor Mount Frame	38	S-4329	Bolt, HHCS 5/8"-11 x 2" YDP Grade 8 or 8.2
14	GK4222-BS	Center Pivot Weldment - Bin Silver	39	S-8349	Nylock Nut 5/8"-11 ZN Grade 2
15	GK4229	Splice Plate for Shield	40	S-3214	Hex Nut 7/8"-9 YDP Grade 2
16	GK4250	Belt Guard Spacer Pipe	41	S-8276	Long Square Key 1/4" x 1/4" x 3"
17	GK4840	Enclosed Chain Drive (2 to 1) - 6"	42	GK5610	Back Plate Assembly
17	GK4841	Enclosed Chain Drive (2 to 1) - 8"	43	S-9066	Flange Bolt 3/8"-16 x 1-1/4" ZN Grade 5
18	GK4842	8" x 1" Bore 2 Belt Aluminum Sheave	44	S-8316	Bolt, HHCS 7/16"-14 x 3" ZN Grade 8
18	GK1983	10" x 1" Bore 2 Belt Aluminum Sheave	45	S-7383	3/8" Nylock Nut ZN Grade 5
19	S-8317	7/16"-14 Stover Nut Zinc Grade C - 6"			

2 to 1 Enclosed Chain Drive

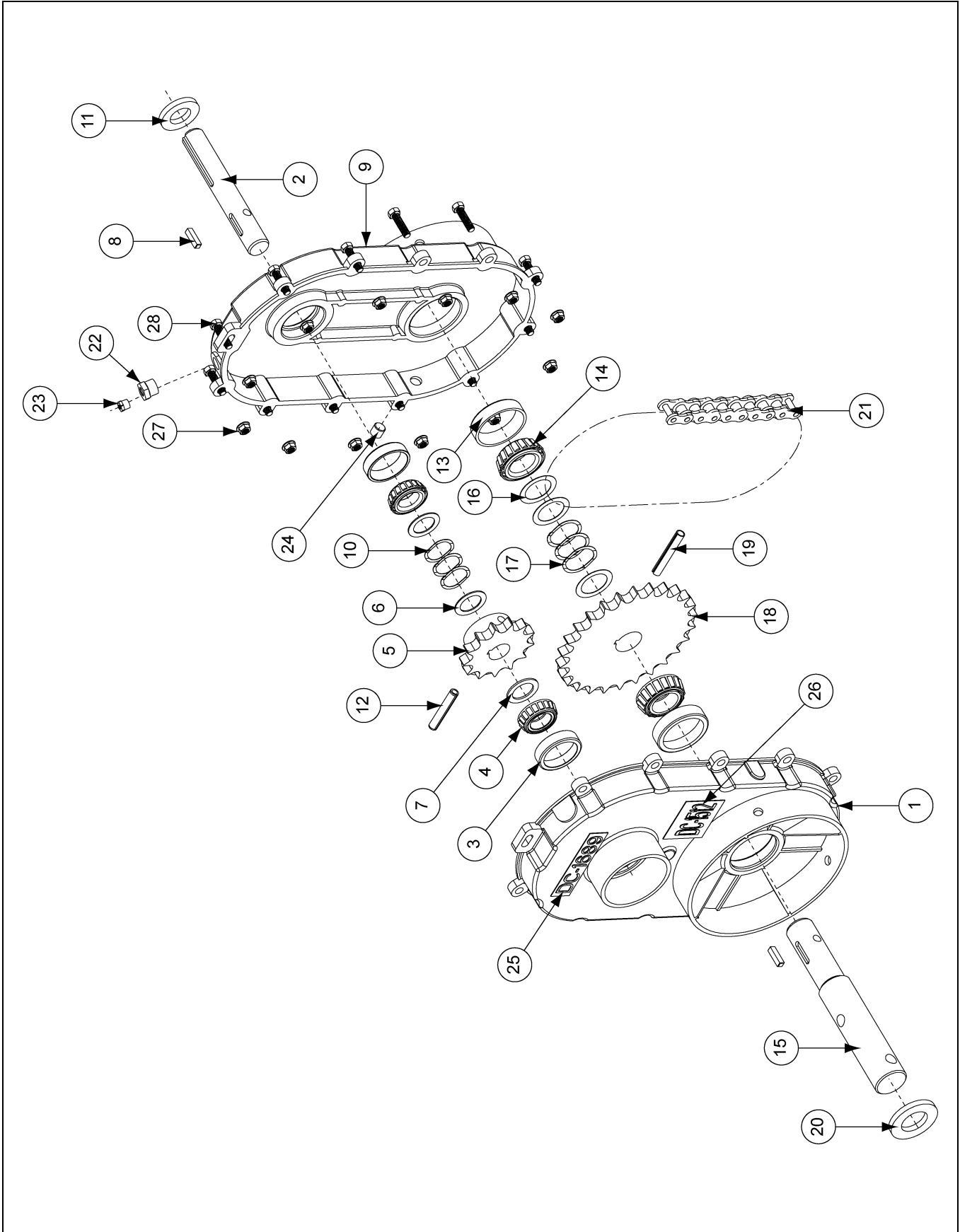

2 to 1 Enclosed Chain Drive Parts List

Ref #	Part #	Description
1	GK6349	Aluminum Casting Cover (Inside)
2	GK6346	Input Shaft - 1"
3	GK3247	1" Bearing Cup (Timken # 07204)
4	GK3242	1" Bearing Cone (Timken # 07100)
5	GK5217	1" Bore Sprocket, #60 13 Tooth
6	GK6782	Machinery Bushing, 1" I.D. x 0.048"
7	GK6328	Machinery Bushing, 1" I.D. x 0.075"
8	S-9168	Square Key, 1/4" x 1"
9	GK6343	Aluminum Casting Cover (Outside)
10	GK7735	Wave Spring, 1-3/8" O.D.
11	GK3251	Input Shaft Oil Seal, 1"
12	3358A1	Pin, Spring 3/8" x 2-1/4" Plain Steel Slotted Rolled
13	GK2383	1-1/4" Bearing Cup (Timken # 15245)
14	GK2367	1-1/4" Bearing Cone (Timken # 15123)
15	GK6344	6" Sweep Output Shaft, 1-1/4"
15	GK6345	8" Sweep Output Shaft, 1-1/2" - 1-1/4"
16	GK7794	Shim, 1-3/4" O.D. x 1-1/4" I.D. x 0.020"
17	GK7734	Wave Spring, 1-5/8" O.D.
18	GK5990	1-1/4" Bore Sprocket, #60 39-Tooth
19	S-7245	Pin, Spring 3/8" x 2-1/2" Plain Steel Slotted Rolled
20	GK2374	Output Shaft Oil Seal, 1-1/4"
21	GK5991	#60 Roller Chain - 39 Pitch
22	GK5350	Pipe Bushing, 1/8" x 3/8" NPT
23	GK2697	Plug, 1/8"-27 NPT Vent
24	FLX-3788	Plug, 1/4" NPT Pipe
25	DC-1689	Decal, 2 to 1 Ratio
26	DC-1512	Decal, Notice Oil Level 3 Point
27	S-3611	Flange Nut 5/16"-18 YDP Grade 2
28	S-4276	Bolt, HHCS 5/16"-18 x 1-1/4" ZN Grade 5

NOTES

Limited Warranty - N.A. Grain Products

The GSI Group, LLC. ("GSI") warrants products which it manufactures, to be free of defects in materials and workmanship under normal usage and conditions for a period of 12 months from the date of shipment (or, if shipped by vessel, 14 months from the date of arrival at the port of discharge). If, in GSI's sole judgment, a product is found to have a defect in materials and/or workmanship, GSI will, at its own option and expense, repair or replace the product or refund the purchase price. This Limited Warranty is subject to extension and other terms as set forth below.

Warranty Enhancements:

The warranty period for the following products is enhanced as shown below and is in lieu of (and not in addition to) the above stated warranty period. (Warranty Period is from date of shipment.)

	Product	Warranty Period
Storage	Grain Bin Structural Design	5 Years
	• Roof, doors, platforms and walk arounds	
	• Flooring (when installed using GSI specified floor support system for that floor)	
Conditioning	Dryer Structural Design - (Tower, Portable and TopDry)	5 Years
	• Includes (frame, portable dryer screens, ladders, access doors and platforms)	2 Years
	All other Dryer parts including:	
	• Electrical (controls, sensors, switches and internal wiring)	2 Years
Material Handling	Bullseye Controllers	2 Years
	Bucket Elevators Structural Design	5 Years
	Towers Structural Design	5 Years
	Catwalks Structural Design	5 Years
	Accessories (stairs, ladders and platforms) Structural Design	5 Years

Conditions and Limitations:

THERE ARE NO WARRANTIES THAT EXTEND BEYOND THE LIMITED WARRANTY DESCRIPTION SET FORTH HEREIN; SPECIFICALLY, GSI DISCLAIMS ANY AND ALL OTHER WARRANTIES OF ANY KIND, EXPRESS OR IMPLIED, INCLUDING, WITHOUT LIMITATION, WARRANTIES OF MERCHANTABILITY OR FITNESS FOR A PARTICULAR PURPOSE OR USE IN CONNECTION WITH: (I) ANY PRODUCT MANUFACTURED OR SOLD BY GSI, OR (II) ANY ADVICE, INSTRUCTION, RECOMMENDATION OR SUGGESTION PROVIDED BY AN AGENT, REPRESENTATIVE OR EMPLOYEE OF GSI REGARDING OR RELATED TO THE CONFIGURATION, INSTALLATION, LAYOUT, SUITABILITY FOR A PARTICULAR PURPOSE, OR DESIGN OF SUCH PRODUCTS.

The sole and exclusive remedy for any claimant is set forth in this Limited Warranty and shall not exceed the amount paid for the product purchased. This Warranty only covers the value of the warranted parts and equipment, and does not cover labor charges for removing or installing defective parts, shipping charges with respect to such parts, any applicable sales or other taxes, or any other charges or expenses not specified in this Warranty. GSI shall not be liable for any other direct, indirect, incidental or consequential damages, including, without limitation, loss of anticipated profits or benefits. Expenses incurred by or on behalf of a claimant without prior written authorization from the GSI warranty department shall not be reimbursed. This warranty is not transferable and applies only to the original end-user. GSI shall have no obligation or responsibility for any representations or warranties made by or on behalf of any dealer, agent or distributor. Prior to installation, the end-user bears all responsibility to comply with federal, state and local codes which apply to the location and installation of the products.

This Limited Warranty extends solely to products sold by GSI and does not cover any parts, components or materials used in conjunction with the product, that are not sold by GSI. GSI assumes no responsibility for claims resulting from construction defects, unauthorized modifications, corrosion or other cosmetic issues caused by storage, application or environmental conditions. Modifications to products not specifically delineated in the manual accompanying the product at initial sale will void all warranties. This Limited Warranty shall not extend to products or parts which have been damaged by negligent use, misuse, alteration, accident or which have been improperly/inadequately maintained.

Notice Procedure:

In order to make a valid warranty claim a written notice of the claim must be submitted, using the RMA form, within 60 days of discovery of a warrantable nonconformance. The RMA form is found on the OneGSI portal.

Service Parts:

GSI warrants, subject to all other conditions described in this Warranty, Service Parts which it manufactures for a period of 12 months from the date of purchase unless specified in Enhancements above.

(Limited Warranty - N.A. Grain Products_ revised 19 October 2018)

This equipment shall be installed in accordance with the current installation codes and applicable regulations, which should be carefully followed in all cases. Authorities having jurisdiction should be consulted before installations are made.



**1004 E. Illinois St.
Assumption, IL 62510-0020
Phone: 1-217-226-4421
Fax: 1-217-226-4420
www.gsiag.com**

