

PNEG-1057

07-19-10

Revision No. 1

8" and 10" Commercial Vertical Bin Unload Auger

Assembly & Operation Manual

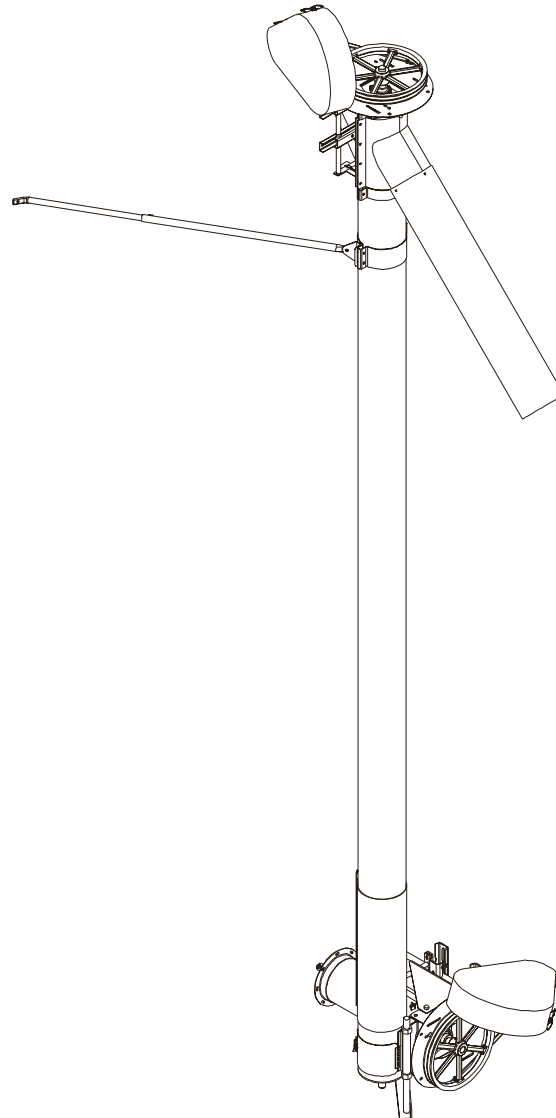

**PNEG-1057
07-19-10
Revision No. 1**

**8" and 10" Commercial
Vertical Bin Unload Auger**

SAFETY GUIDELINES

This manual contains information that is important for you, the owner/operator, to know and understand. This information relates to protecting **personal safety** and **preventing equipment problems**. It is the responsibility of the owner/operator to inform anyone operating or working in the area of this equipment of these safety guidelines. To help you recognize this information, we use the symbols that are defined below.

Please read the manual and pay attention to these sections. Failure to read this manual and its safety instructions is a misuse of the equipment and may lead to serious injury or death.



This is the safety alert symbol. It is used to alert you to potential personal injury hazards. Obey all safety messages that follow this symbol to avoid possible injury or death.



DANGER indicates an imminently hazardous situation which, if not avoided, will result in death or serious injury.



WARNING indicates a potentially hazardous situation which, if not avoided, could result in death or serious injury.



CAUTION indicates a potentially hazardous situation which, if not avoided, may result in minor or moderate injury.



CAUTION used without the safety alert symbol indicates a potentially hazardous situation which, if not avoided, may result in property damage.



NOTE indicates information about the equipment that you should pay special attention to.

SAFETY GUIDELINES

1. General Safety Guidelines

- A. **DO NOT** make any alterations to the equipment. Such alterations may produce a very dangerous situation, where **SERIOUS INJURY** or **DEATH** may occur.
- B. This equipment shall be installed in accordance with any regulations or installation codes that are required by law. Authorities having jurisdiction should be consulted before installations are made.
- C. Untrained operators subject themselves and others to **SERIOUS INJURY** or **DEATH**. **NEVER** allow untrained personnel to operate this equipment.
- D. Keep children and other unqualified personnel out of the working area at **ALL** times.
- E. **NEVER** start equipment until **ALL** persons are clear of the work area.
- F. Be sure **ALL** operators are adequately rested and prepared to perform **ALL** functions of operating this equipment.
- G. Keep hair, loose clothing, and shoestrings away from rotating and moving parts. **NEVER** wear loose fitting clothing when working around augers.
- H. **NEVER** allow any person intoxicated or under the influence of alcohol or drugs to operate the equipment.
- I. **NEVER** allow anyone inside a bin, truck, or wagon which is being unloaded by an auger or conveyor. Flowing grain can trap and suffocate in seconds.
- J. Make sure someone is nearby who is aware of the proper shutdown sequence in the event of an accident or emergency.
- K. **NEVER** work alone.
- L. **ALWAYS** think before acting. **NEVER** act impulsively around the equipment.
- M. Make sure **ALL** equipment is locked in position before operating.
- N. Keep hands and feet away from the auger intake and other moving parts.
- O. **NEVER** attempt to assist machinery operation or to remove trash from equipment while in operation.
- P. **NEVER** drive, stand, or walk under the equipment.
- Q. Use caution not to hit the auger when positioning the load.
- R. Use ample overhead lighting after sunset to light the work area.
- S. **ALWAYS** lockout **ALL** power to the equipment when finished unloading.
- T. Keep area around intake free of obstacles such as electrical cords, blocks, etc. that might trip workers.

SAFETY GUIDELINES

2. Personal Protective Equipment

A. The proper personal protective equipment should be worn at **ALL** times by anyone in the work area.



2-B

B. **ALWAYS** wear safety glasses when in the work area.



2-C

C. The operator should **NEVER** wear jewelry.

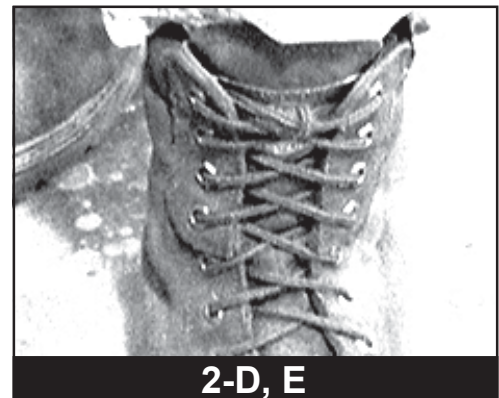

2-D, E

D. Loose clothing should not be worn. Any clothing that becomes loosened should be tucked in tightly.

E. Loose or dangling shoe strings should be tucked in.



2-F

F. Long hair should be tied up and/or back.

SAFETY GUIDELINES

3. Emergency Shutdown Sequence

- A. In an emergency, shutdown the power source.

4. Pinch Points

NOTE

A Pinch Point is any place on the equipment which can injure the operator.

- A. Components of this equipment have sharp edges which can scrape and/or cut an operator.
- B. A moving auger can sever an operator's limbs or even kill him/her.

5. Shields and Guards

- A. **ALWAYS** keep **ALL** shields and guards in place during operation.

We will replace any missing shields or guards free of charge!

See (page VI) for more information on our Safety First program.

Safety **1st**

6. Operator Qualifications

- A. The User/Operator must be competent and experienced to operate auger equipment. Anyone who works with or around augers must have good common sense in order to be qualified. These persons must also know and meet all other qualifications, such as:
 - 1. Any person who has not read and/or does not understand all operation and safety procedures is not qualified to operate any auger systems.
 - 2. Certain regulations apply to personnel operating power machinery. Personnel under the age of 18 years may not operate power machinery, including augers. It is your responsibility, as owner and/or supervisor, to know what these regulations are in your area or situation.
 - 3. Unqualified or incompetent persons are to remain out of the work area.
 - 4. O.S.H.A. (Occupational Safety & Health Administration) regulations state:
"At the time of initial assignment and at least annually thereafter, the employer shall instruct every employee in the safe operation and servicing of all equipment with which the employee is, or will be involved." (Federal Occupational Safety & Health Standards for Agriculture. Subpart D, Section 19287.57 (a) (6).

SAFETY GUIDELINES

6. Operator Qualifications (*cont.*)

B. As a requirement of OSHA, it is necessary for the employer to train the employee in the safe operating and safety procedures for this auger. We included this sign-off sheet for your convenience and personal record keeping. All unqualified persons are to stay out of the work area at all times. It is strongly recommended that another qualified person who knows the shutdown procedure is in the area in the event of an emergency. A person who has not read this manual and understands all operating and safety instructions is not qualified to operate the machine.

Date	Employer's Signature	Employee Signature
1		
2		
3		
4		
5		
6		
7		
8		
9		
10		
11		
12		
13		
14		
15		
16		
17		
18		
19		
20		
21		
22		

SAFETY GUIDELINES



Our equipment is built to provide many years of dependable service to our customers through durable craftsmanship.

One of the most important aspects of our engineering is **SAFETY 1st** design throughout all product lines. At our company - safety is NO ACCIDENT!

That is why we have implemented a **SAFETY 1st** program. Should you ever need guards, shields, safety decals or owner/operator manuals, simply contact us or your local dealer, and we will supply you with them **FREE OF CHARGE!**

While it is our main goal for our company to be the world leader in auger manufacturing, it is always our first priority to keep our customers safe.

If you need any of the above listed safety items or have any safety questions, please contact the manufacturer or your local dealer.

We replace missing guards and shields
FREE OF CHARGE!

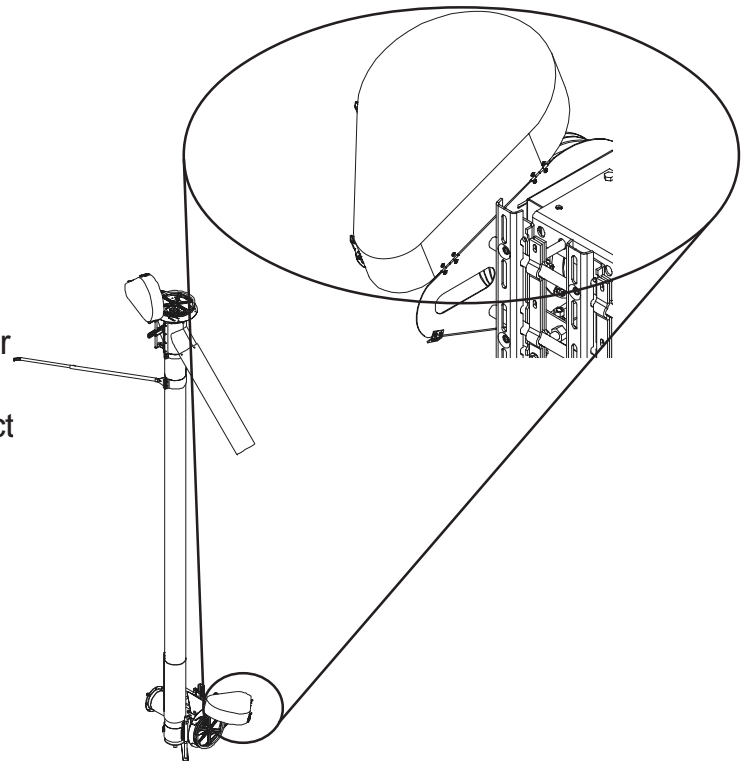

Personnel operating or working around this equipment should read this manual. This manual must be delivered with equipment to its owner. Failure to read this manual and its safety instructions is a misuse of the equipment. Any misuse of the equipment may void the warranty.

Safety Guidelines	i
SAFETY 1st	vi
Table of Contents	vii
Decals	1
Introduction	4
8" Vertical Assembly	5
10" Vertical Assembly	10
Operation & Maintenance	16
Startup	15
Shutdown	19
Troubleshooting	20
8" Parts List	21
10" Parts List	23
Warranty	

Safety Decals

A. The image below shows the location of the decals and safety signs which should appear on the Commercial Vertical Bin Unload Auger. Samples and explanations of these decals are shown on page 2.

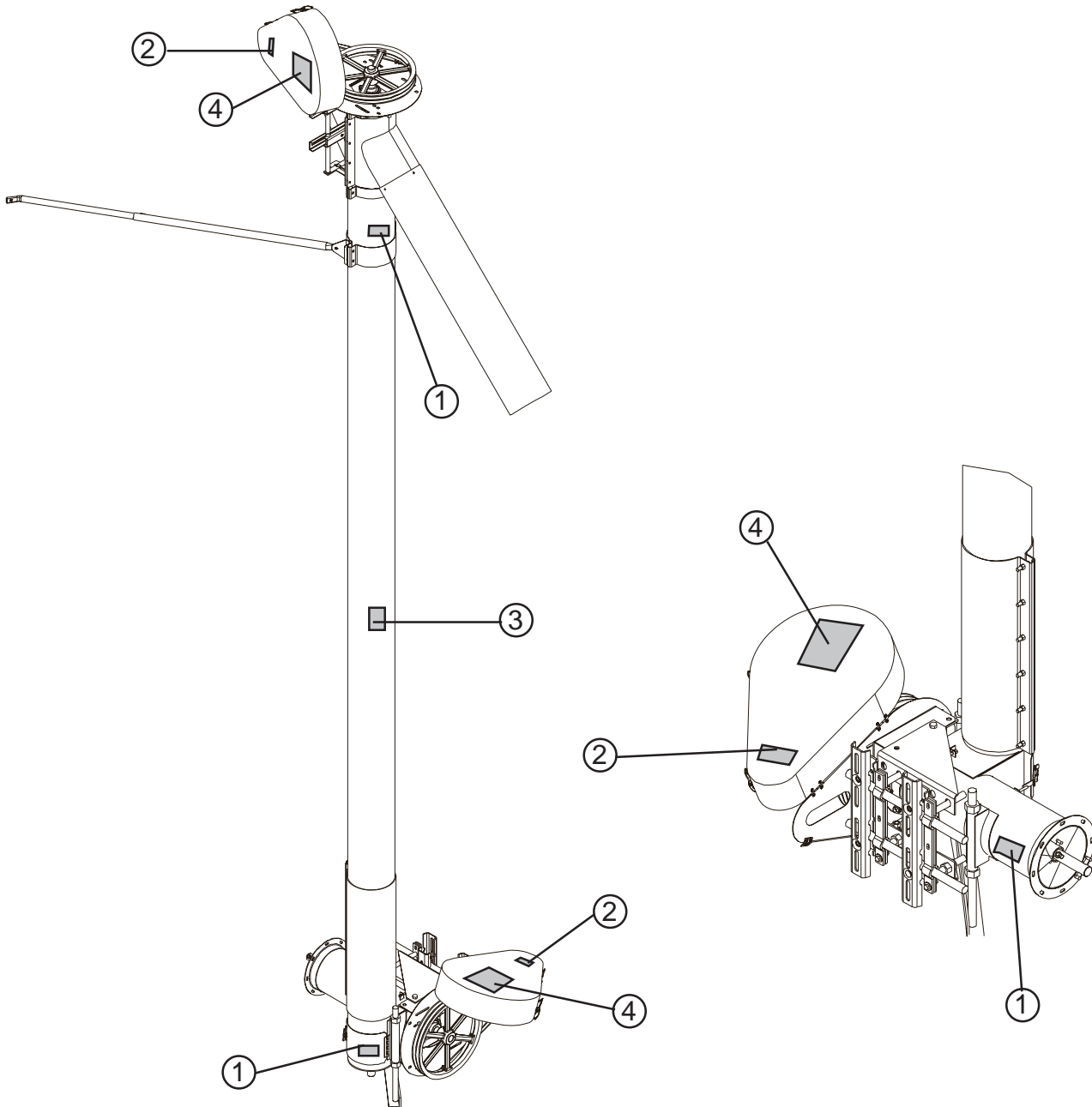

NOTE

Please remember safety signs provide important safety information for people working near bin unloading equipment that is in operation. Any safety signs that are worn, missing, illegible or painted over should be replaced immediately. Obtain **FREE** replacements by contacting your dealer.

Safety Decals

The Safety Decals chart below lists all the safety decals that should be included with the auger. Inspect all decals and replace any that are illegible, worn, or missing. Contact your dealer or the manufacturer to order replacement decals.

Safety Decals				
Ref. #	Part #	Qty.	Description	Size
1	DC-1381	1	Danger - Shear Point	4-1/2" x 2"
2	DC-995	1	Warning—Shear Point	4-1/2" x 2"
3	DC-1234	1	Caution	2-1/4" x 2-3/4"
4	DC-1379	1	Notice	5-1/8" x 7-3/8"

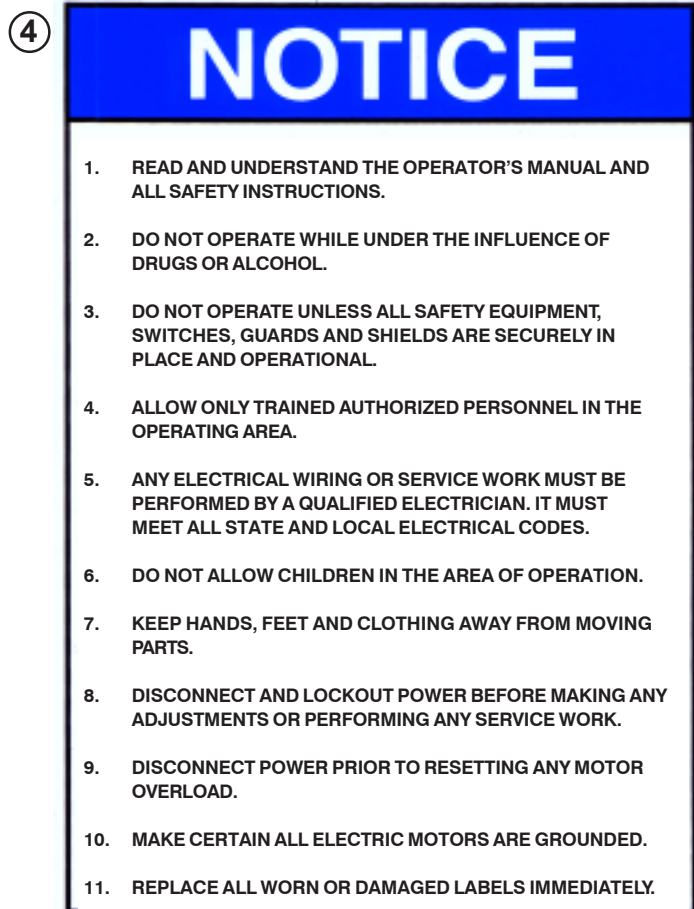
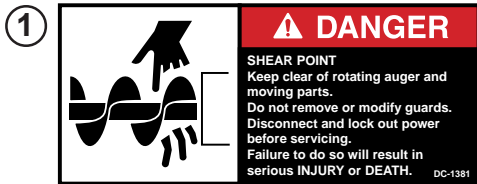

Safety Decals

- DANGER Sign No. DC-1395 was supplied with your bin unloading equipment. This safety sign should be applied to the side of the bin near the bin opening, so it will be viewed by people entering into the bin storage building. Do not cover any safety signs or any other signs that are already there.
- If the safety sign location suggested is not in full view because of equipment modifications, other equipment in the area, or any reason, then locate the safety sign in a more suitable location.
- Be certain the surface is clean, dry and free of dirt and oil. Peel paper backing from decals and stick into place. The adhesive backing will bond on contact.

NOTE

Please remember, safety signs provide important safety information for people working near bin unloading equipment that is in operation.

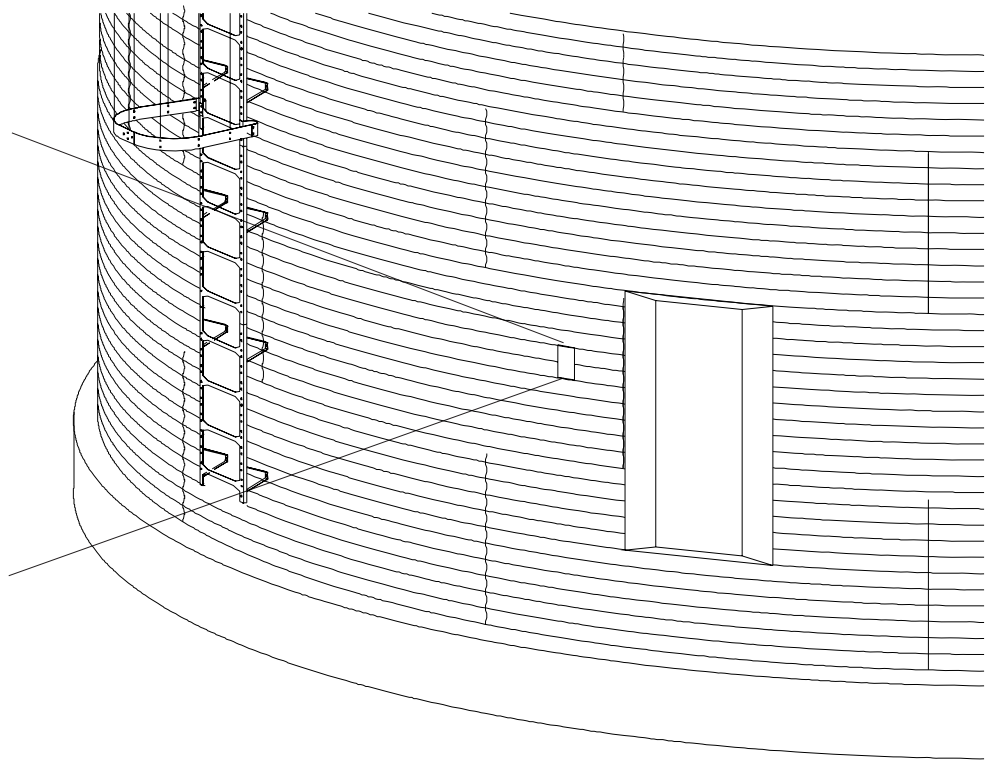
⚠ WARNING

If the Safety Sign cannot be easily read for any reason or has been painted over, replace it immediately. Additional Safety Signs may be obtained *free of charge* from your dealer, distributor, or ordered from the factory.

Order SAFETY SIGN NO. DC-1395

1. General Information

- A. We reserve the right to improve our product whenever possible and practical to do so. We reserve the right to change, improve, and modify products at any time without obligation to make changes, improvements, and modifications on equipment sold previously.
- B. The 8" & 10" Commercial Vertical Bin Unload Augers have been designed and manufactured to give years of dependable service. The care and maintenance of this machine will affect the satisfaction and service obtained. By observing the instructions and suggestions we have recommended, the owner should receive competent service for many years. If additional information or assistance should be required, please contact the factory or your local dealer.
- C. When receiving merchandise, it is important to check both the quantity of parts and their descriptions with the packing list enclosed within each package. All claims for freight damage or shortage must be made by the consignee within ten (10) days from the date of the occurrence of freight damage. The consignee should accept the shipment after noting the damage or loss.

2. Capacity

- A. The capacities may vary greatly under varying conditions. The following factors play a role in the performance of the auger:
 - Speed
 - Angle of operation
 - Moisture content
 - Amounts of foreign matter
 - Different materials
 - Methods of feeding
- B. For example, a twenty-five percent (25%) moisture could cut capacity by as much as 40% under some conditions.

1. Motor Mount Rod to Head Plate Assembly

- A. Screw one 3/4" hex head nut to the top of each motor mount rod (10).
- B. Slide the motor mount rods (10) through the head plate assembly (11).
- C. Line up slot on the plate end of the motor mount rods (10) with the slot on the head plate assembly (11). Fasten them together using 5/16" carriage bolt, a flat washer, and a nut.
- D. Attach a 3/4" hex head nut onto the bottom of each motor mount rod. Tighten until nut rests against the head plate assembly (11).
- E. Adjust top 3/4" hex head nuts down until they rests against the top of the head plate assembly (11).

2. Tube Assembly

- A. Connect the two-hole flange bearing (12) to head plate assembly (11) using two 7/16" x 1-1/4" bolts with locknuts.
- B. Loosen the top and bottom nuts on the head plate assembly (11) to allow the belt guard mounting angles (35) to slide onto the motor mount rods (10). Once the angles are in place tighten nuts to keep rods in position.
- C. Connect head drive shaft (13) to flight using two 7/16" x 2-1/4" (grade 5) bolts with locknuts.
- D. Slide head plate assembly (11) over discharge end of tube and tighten the halfband clamps (5) using four 5/16" x 1-1/2" bolts with nuts. Slip bearing lock collar (not shown) over head drive stub.
- E. Fasten belt guard (17) to top mounting angle (35) using two 5/16" x 3/4" carriage bolts with flat washers, lockwashers, and nuts.

NOTE**Leave carriage bolts loose until later.**

- F. Place head drive shaft (13) through head bearing with enough extended to mount pulley (18) with key (37). Tighten lock collar on bearing and tighten setscrews in pulley.
- G. Install motor and pulley onto motor mount. **(Motor and pulley are not included.)** Install belts (3) and tighten by adjusting motor height by using the four 3/4" nuts on the rods.
- H. Close door on belt guard and latch.
- I. Secure 45° discharge spout (6) Over the discharge opening using the head plate assembly and eight 5/16" x 1-1/2" long bolts with nuts.

8" Vertical Tube Assembly

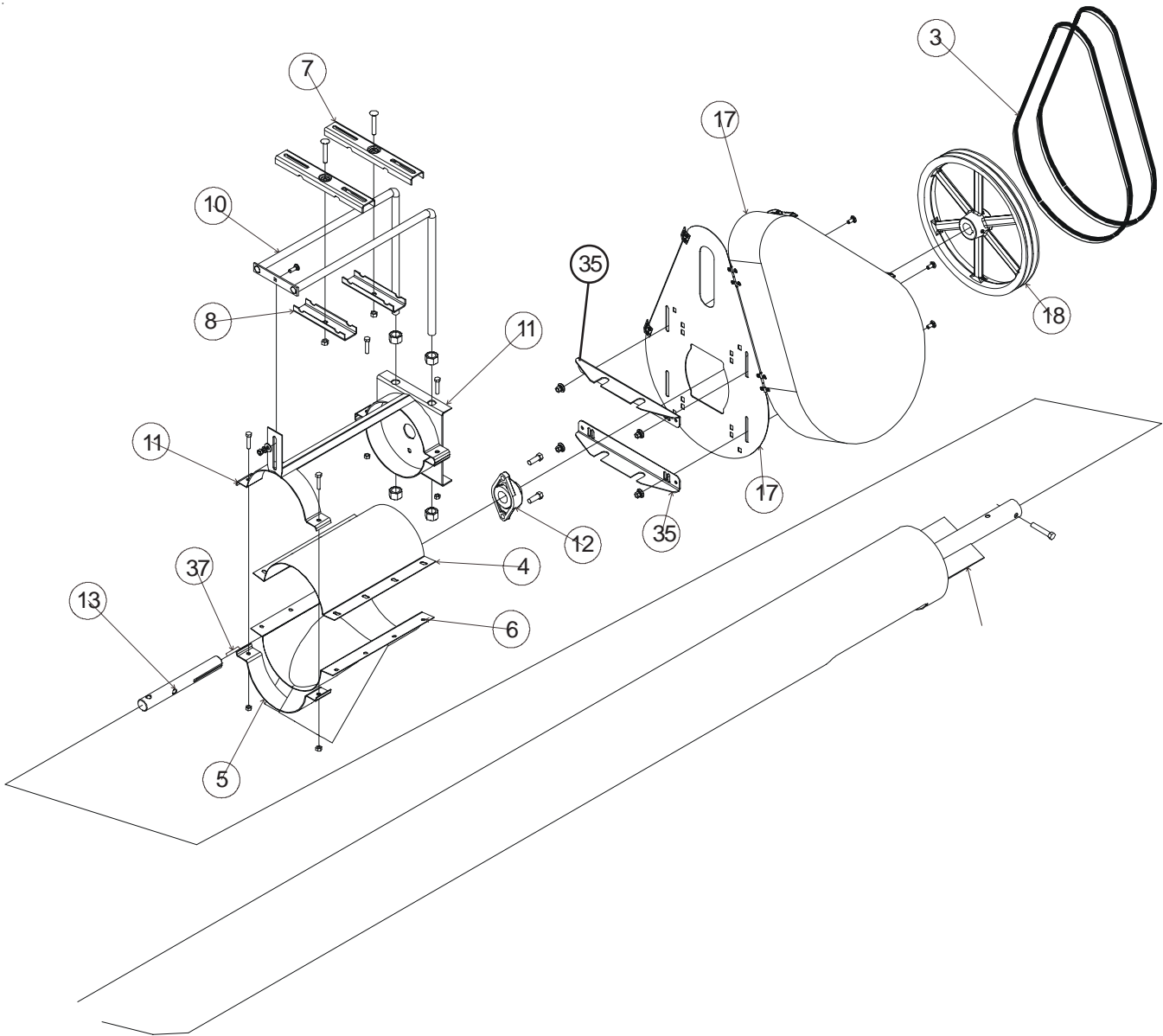

Lock out all power sources while installing or maintaining equipment.



Keep all safety devices and shields in place at all times until power source is locked out.

3. Attaching Vertical Section to Bin

- A. Slide bin unloading flight into bin well and unloading tube (which should already be installed in bin.)
The unloading flight for larger bin sizes may need to be bolted together. Use bolts provided in connecting stubs located at the end of the tail flights. See the 8" Flight Chart below to determine the flight length for your bin size.
- B. Bolt unloading flight to short horizontal flight (#3 on page 9) using four 7/16" x 2-3/4" long (grade 5) bolts and locknuts.
- C. Bolt flange on horizontal tube of vertical unloader to the flange of the bin unloader tube with vertical auger in vertical position. Use eight 5/16" x 1" long bolts, lockwashers, and nuts.

8" FLIGHT CHART			
Product No.	Bin Dia.	Part No.	Description
GFC82400	24'	GK1799	14' -6" x 7" O.D. Flight
GFC82700	27'	GK1800	16' -0" x 7" O.D. Flight
GFC83000	30'	GK1801	17' -6" x 7" O.D. Flight
GFC83300	33'-34'	GK1802	19' -6" x 7" O.D. Flight
GFC83600	36'	GK1803	20' -6" x 7" O.D. Flight
GFC83800	37'-39'	GK1804	22' -6" x 7" O.D. Flight
GFC84000	40'	GK1805	23' -0" x 7" O.D. Flight
GFC84200	42'	GK1806	24' -0" x 7" O.D. Flight
GFC84800	48'-49'	GK1808	20' -0" x 7" O.D. Flight (Head)
		GK1807	7' -0" x 7" O.D. Flight (Tail)
GFC85400	54'-55'	GK1808	20' -0" x 7" O.D. Flight (Head)
		GK1809	10' -0" x 7" O.D. Flight (Tail)
GFC86000	60'	GK1808	20' -0" x 7" O.D. Flight (Head)
		GK1810	13' -0" x 7" O.D. Flight (Tail)
GFC86300	63'	GK1808	20' -0" x 7" O.D. Flight (Head)
		GK1811	14' -6" x 7" O.D. Flight (Tail)
GFC86800	68'-69'	GK1808	20' -0" x 7" O.D. Flight (Head)
		GK1812	17' -0" x 7" O.D. Flight (Tail)
GFC87200	72'	GK1808	20' -0" x 7" O.D. Flight (Head)
		GK1813	19' -0" x 7" O.D. Flight (Tail)
GFC87500	75'	GK1808	20' -0" x 7" O.D. Flight (Head)
		GK1814	20' -6" x 7" O.D. Flight (Tail)
GFC87800	78'	GK1808	20' -0" x 7" O.D. Flight (Head)
		GK1815	22' -6" x 7" O.D. Flight (Tail)
GFC88000	80'	GK1808	20' -0" x 7" O.D. Flight (Head)
		GK1130	20' -0" x 7" O.D. Flight (Middle)
		GK1821	4' -6" x 7" O.D. Flight (Tail)
GFC88200	82'	GK1808	20' -0" x 7" O.D. Flight (Head)
		GK1130	20' -0" x 7" O.D. Flight (Middle)
		GK1823	5' -6" x 7" O.D. Flight (Tail)
GFC89000	90'	GK1808	20' -0" x 7" O.D. Flight (Head)
		GK1130	20' -0" x 7" O.D. Flight (Middle)
		GK1824	9' -6" x 7" O.D. Flight (Tail)
GFC89200	92'	GK1808	20' -0" x 7" O.D. Flight (Head)
		GK1130	20' -0" x 7" O.D. Flight (Middle)
		GK1825	10' -6" x 7" O.D. Flight (Tail)

3. Attaching Vertical Section to Bin (cont.)

- D. Adjust stand (#40 on page 9) so it holds the weight of the vertical auger.
- E. Attach the support brackets and halfbands to the top half of the vertical tube by inserting the 5/16" U-bolt (4) through the support brackets (5) and halfbands (6) and fasten together using four 5/16" nylon locknuts.
- F. Attach lower telescoping tube sections (3) to the ears on the support brackets (5) using two 3/8" x 3/4" bolts with locknuts.
- G. Slide the upper telescoping tube sections (1) into the lower tube sections (3). Attach upper tubes to the bin wall.
- H. Secure the upper telescoping tubes to the lower telescoping tubes by tightening the square head setscrew (2).

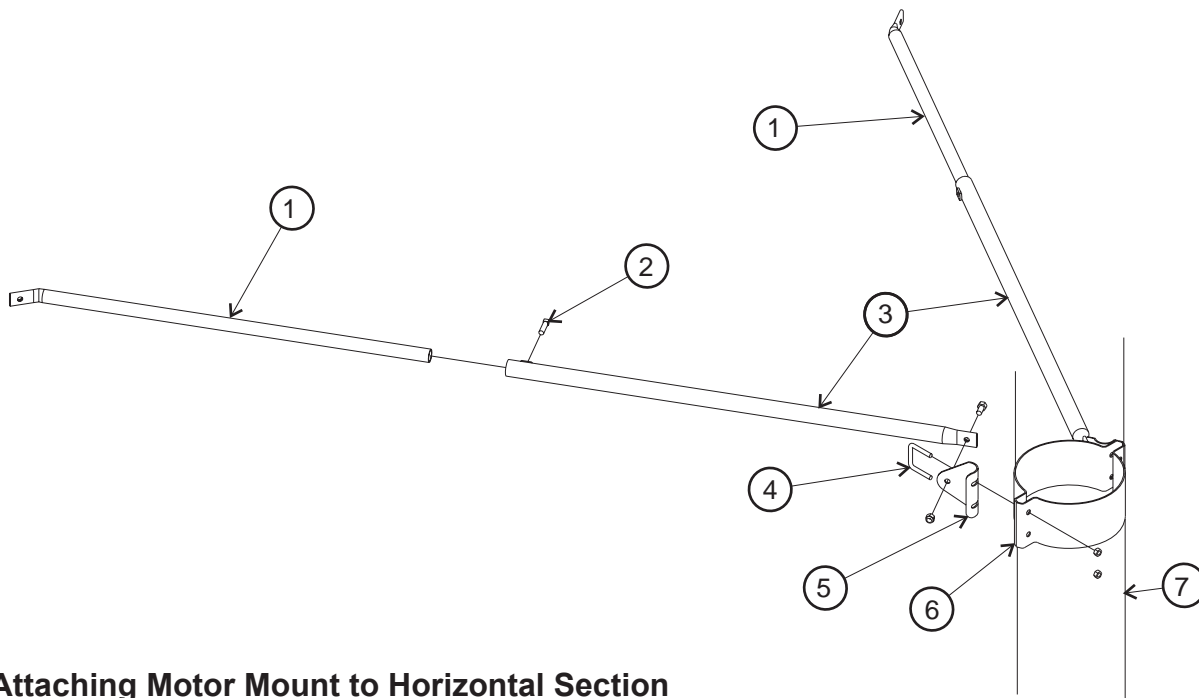

4. Attaching Motor Mount to Horizontal Section

- A. First, connect the head stub shaft (13) to the short flight (3) using two 7/16" x 2-3/4" (grade 5) bolts with locknuts.
- B. Connect the four-hole flange bearing with lock collar (4) and the head plate (28) together using four 7/16" x 1-1/4" bolts with locknuts.
- C. Attach the head plate (28) to the tube flange using eight 5/16" x 1" bolts with flat washers, lockwashers, and nuts.
- D. Connect side plates (22) and (23) to head plate (28) using four 1/2" x 1" bolts with lockwashers and nuts. Also, at the same time attach the top and bottom belt guard brackets (27) using the same bolts.
- E. Spin a 3/4" nut on the threaded rods of each strap and rod assembly (24). Insert threaded rods through holes in side plates (22) & (23) and add four more 3/4" nuts. Leave only finger tight until later.
- F. Place rods (26) in strap and rod assemblies (24) and secure with top straps (25) using 3/8" x 1-1/2" bolts with two flat washers and one nut on each bolt.

- G. Position motor mount straps (15) and clips (14) and secure to rod (26) using four 3/8" x 3" long carriage bolts with nuts. Leave only finger tight until motor is installed and adjusted.
- H. Attach belt guard (17) to belt guard mounting angles (27) using four 5/16" x 3/4" carriage bolts with flat washers and nuts.
- I. Slide bearing lock collar (4) over head stub shaft (13). Leave enough stub exposed to mount pulley (18) on stub with drive key (37). Tighten bearing lock collar next to bearing and tighten set screws in pulley.
- J. Install pulley on head stub shaft and mount motor on strap (15). (**Motor and pulley not furnished.**) Install belts (2) and align pulleys. Tighten motor to straps (15). Adjust motors along the tube and tighten with 3/8" x 3" carriage bolts.
- K. After everything has been adjusted correctly, go back and tighten all nuts and bolts.

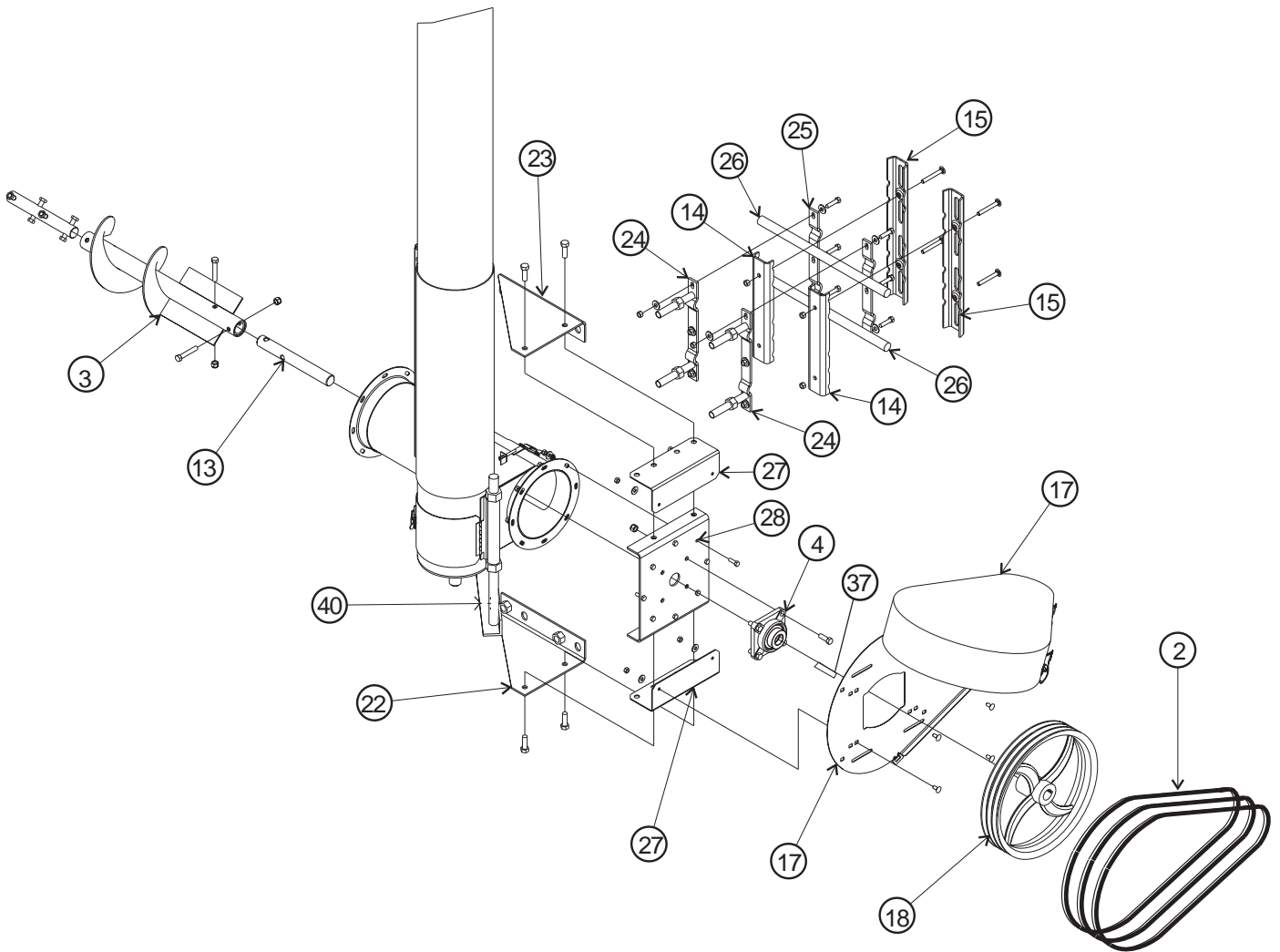

5. Motor Mount Rod to Head Plate Assembly

- A. Screw one 7/8" hex head nut to the top of each motor mount rod (13).
- B. Slide the motor mount rods through the head plate assembly.
- C. Line up slot on the plate end of the motor mount rods (13) with the slot on the head plate assembly (7). Fasten them together using 3/8" carriage bolt, a split flat washer, and a nut.
- D. Attach a 7/8" hex head nut onto the bottom of each motor mount rod. Tighten until nut rests against the head plate assembly (7).
- E. Adjust top 7/8" hex head nuts down until they rests against the top of the head plate assembly (7).

6. Tube Assembly

- A. Connect the four-hole flange bearing (16) to head plate assembly (7) using four 1/2" x 1-1/2" bolts with locknuts.
- B. Loosen the top and bottom nuts on the head plate assembly (7) to allow the belt guard mounting angles (17) to slide onto the motor mount rods (13). Once the angles are in place tighten nuts to keep rods in position.
- C. Connect head drive stub shaft (18) to flight using two 1/2" x 3.5" (grade 5) bolts with locknuts.
- D. Slide head plate assembly (7) over discharge end of tube and tighten the halfband clamps (9) using four 5/16" x 1-3/4" bolts with nuts. Slip bearing lock collar (not shown) over head drive stub.
- E. Fasten belt guard (20) to top mounting angle (17) using two 5/16" x 3/4" carriage bolts with flat washers, lockwashers, and nuts.

NOTE

Leave carriage bolts loose until later.

- F. Place head drive stub shaft (18) through head bearing with enough extended to mount pulley (19) with key (3). Tighten bearing with lock collar and tighten setscrews in pulley.
- G. Install motor and pulley onto motor mount. **(Motor and pulley are not included.)** Install belts (2) and tighten by adjusting motor height by using the four 3/4" nuts on the rods.
- H. Close door on belt guard and latch.
- I. Secure 45° discharge spout (57) Over the discharge opening using the head plate assembly and eight 5/16" x 1-1/2" long bolts with nuts.
- J. After everything has been adjusted, go back and tighten all nuts and bolts.

10" Vertical Tube Assembly

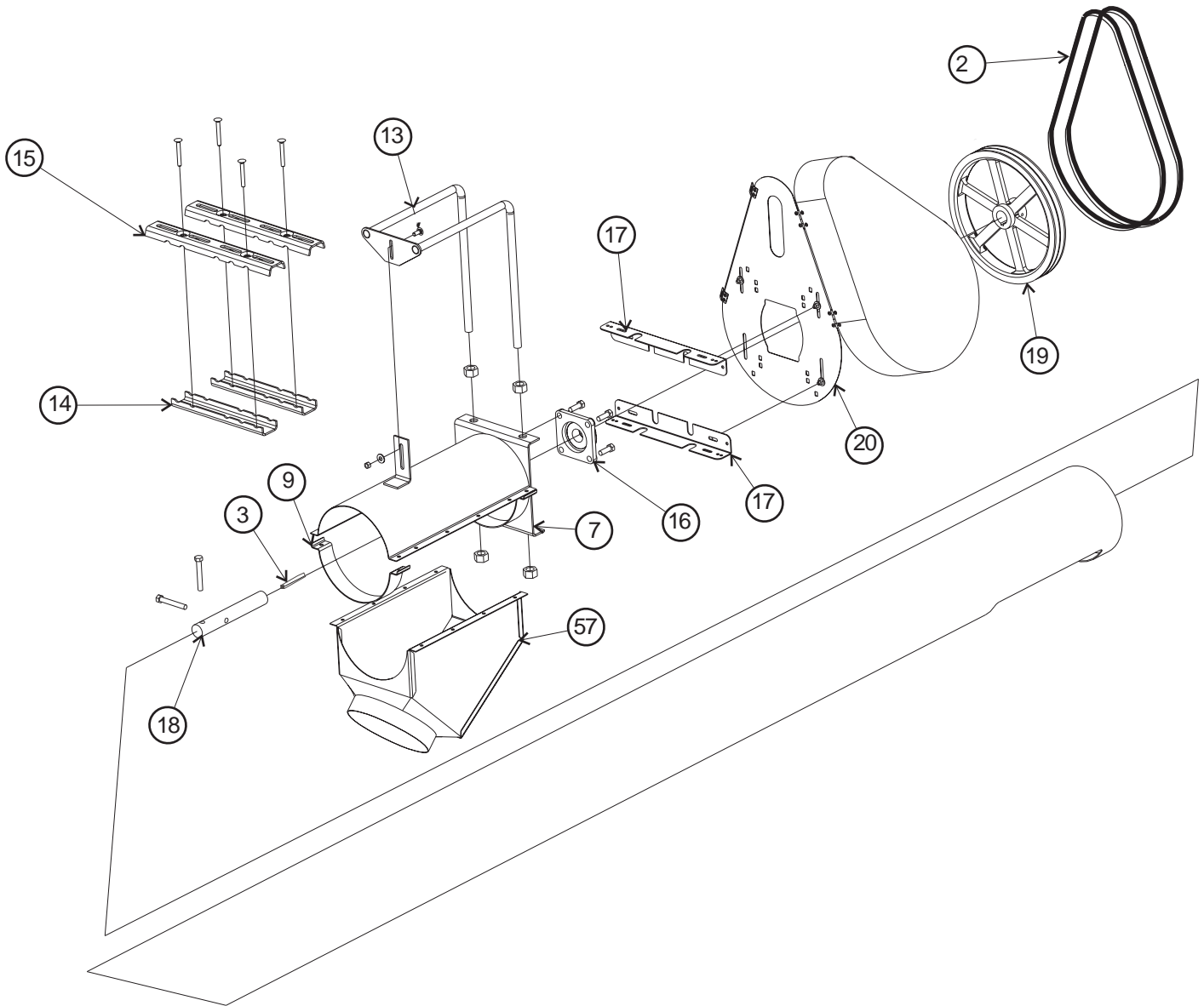

⚠ DANGER Lock out all power sources while installing or maintaining equipment.

⚠ DANGER Keep all safety devices and shields in place at all times until power source is locked out.

7. Attaching Vertical Section to Bin

- A. Slide bin unloading flight into bin well and unloading tube (which should already be installed in bin.)
The unloading flight for larger bin sizes may need to be bolted together. Use bolts provided in connecting stubs located at the end of the tail flights. See the 8" Flight Chart below to determine the flight length for your bin size.
- B. Bolt unloading flight to short horizontal flight (#6 on page 14) using four 1/2" x 3" long (grade 5) bolts and locknuts.
- C. Bolt flange on horizontal tube of vertical unloader to the flange of the bin unloader tube with vertical auger in vertical position. Use eight 5/16" x 1" long bolts, lockwashers, and nuts.

10" FLIGHT CHART			
Product No.	Bin Dia.	Part No.	Description
GFC10240	24'	GK1826	14' -6" x 7" O.D. Flight
GFC10270	27'	GK1827	16' -0" x 7" O.D. Flight
GFC10300	30'	GK1828	17' -6" x 7" O.D. Flight
GFC10330	33'-34'	GK1829	19' -6" x 7" O.D. Flight
GFC10360	36'	GK1830	20' -6" x 7" O.D. Flight
GFC10380	37'-39'	GK1831	22' -6" x 7" O.D. Flight
GFC10400	40'	GK1832	23' -0" x 7" O.D. Flight
GFC10420	42'	GK1833	24' -0" x 7" O.D. Flight
GFC10480	48'-49'	GK1835	20' -0" x 7" O.D. Flight (Head)
		GK1834	7' -0" x 7" O.D. Flight (Tail)
GFC10540	54'-55'	GK1835	20' -0" x 7" O.D. Flight (Head)
		GK1836	10' -0" x 7" O.D. Flight (Tail)
GFC10600	60'	GK1835	20' -0" x 7" O.D. Flight (Head)
		GK1837	13' -0" x 7" O.D. Flight (Tail)
GFC10630	63'	GK1835	20' -0" x 7" O.D. Flight (Head)
		GK1838	14' -6" x 7" O.D. Flight (Tail)
GFC10680	68'-69'	GK1835	20' -0" x 7" O.D. Flight (Head)
		GK1839	17' -0" x 7" O.D. Flight (Tail)
GFC10720	72'	GK1835	20' -0" x 7" O.D. Flight (Head)
		GK1840	19' -0" x 7" O.D. Flight (Tail)
GFC10750	75'	GK1835	20' -0" x 7" O.D. Flight (Head)
		GK1841	20' -6" x 7" O.D. Flight (Tail)
GFC10780	78'	GK1835	20' -0" x 7" O.D. Flight (Head)
		GK1842	22' -6" x 7" O.D. Flight (Tail)
GFC10800	80'	GK1835	20' -0" x 7" O.D. Flight (Head)
		GK1844	20' -0" x 7" O.D. Flight (Middle)
		GK1843	4' -6" x 7" O.D. Flight (Tail)
GFC10820	82'	GK1835	20' -0" x 7" O.D. Flight (Head)
		GK1844	20' -0" x 7" O.D. Flight (Middle)
		GK1845	5' -6" x 7" O.D. Flight (Tail)
GFC10900	90'	GK1835	20' -0" x 7" O.D. Flight (Head)
		GK1844	20' -0" x 7" O.D. Flight (Middle)
		GK1846	9' -6" x 7" O.D. Flight (Tail)
GFC10920	92'	GK1835	20' -0" x 7" O.D. Flight (Head)
		GK1844	20' -0" x 7" O.D. Flight (Middle)
		GK1847	10' -6" x 7" O.D. Flight (Tail)

7. Attaching Vertical Section to Bin (cont.)

- D. Adjust stand (#47 on page 14) so it holds the weight of the vertical auger.
- E. Attach the support brackets and halfbands to the top half of the vertical tube by inserting the 5/16" U-bolt (4) through the support brackets (5) and halfbands (6) and fasten together using four 5/16" nylon locknuts.
- F. Attach lower telescoping tube sections (3) to the ears on the support brackets (5) using two 3/8" x 3/4" bolts with locknuts.
- G. Slide the upper telescoping tube sections (1) into the lower tube sections (3). Attach upper tubes to the bin wall.
- H. Secure the upper telescoping tubes to the lower telescoping tubes by tightening the square head setscrew (2).

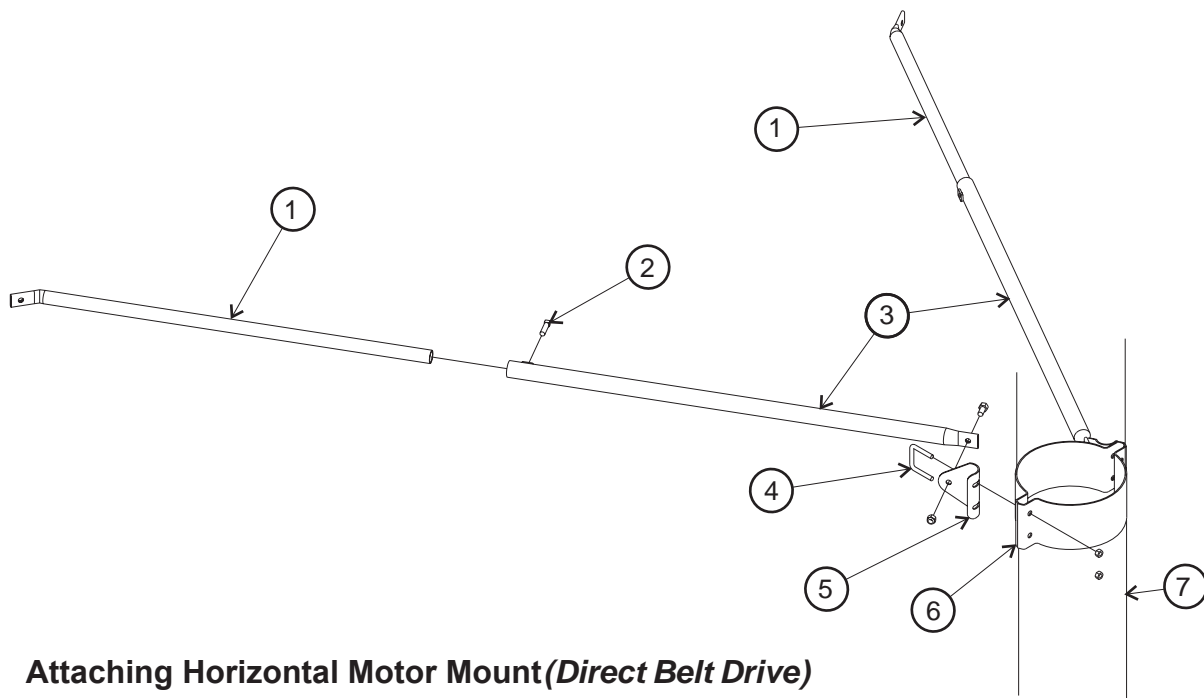

8. Attaching Horizontal Motor Mount (Direct Belt Drive)

- A. First, connect the head stub shaft (39) to the short flight (6) using two 1/2" x 3" (grade 5) bolts with locknuts.
- B. Connect the four-hole flange bearing with lock collar (16) to the head plate (8) together using four 1/2" x 1-1/2" bolts with locknuts.
- C. Attach the head plate (8) to the tube flange using eight 5/16" x 1" bolts with flat washers, lockwashers, and nuts.
- D. Connect side plates (22) and (23) to head plate (8) using four 1/2" x 1-1/4" bolts with lockwashers and nuts. **Also, at the same time, attach the belt guard brackets (21) using the same bolts.**
- E. Spin a 3/4" nut on the threaded rods of each strap and rod assembly (24). Insert threaded rods through holes in side plates (22) & (23) and add four more 3/4" nuts. Leave only finger tight until later.
- F. Place rods (25) in strap and rod assemblies (24) and secure with top straps (26) using 3/8" x 1-1/2" bolts with two flat washers and one nut on each bolt.

- G. Clamp belt guard mounting angle (30) to rod ends (25) with clamp bar (31) using four 5/16" x 1-3/4" bolts with nuts.
- H. Attach belt guard back (28) to belt guard mounting angles (21) using four 5/16" x 3/4" carriage bolts with flat washers and nuts.
- I. Slide bearing lock collar (40) over head stub shaft (39). Leave enough stub exposed to mount pulley (21) on stub with drive key (41). Tighten bearing lock collar next to bearing and tighten set screws in pulley.
- J. Position motor mount straps (15) and clips (14) and secure using four 3/8" x 3" carriage bolts and nuts. Leave finger tight until later.
- K. Install pulley on motor shaft and mount motor on strap (15). (**Motor and pulley not furnished.**) Install belts (3) and align pulleys. Tighten motor to straps (15). Adjust motors along the tube and tighten with 3/8" x 3" carriage bolts.
- L. Set belt tension by adjusting height of motor using 3/4" nuts on rods.
- L. Connect belt guard (29) by bolting belt guard clamp bar (33) to mounting angle (21) using 1/4" x 5-1/2" bolts with nuts. Attach second clamp bar (32) to belt guard mounting brackets (30) using 1/4" x 5-1/2" bolts.

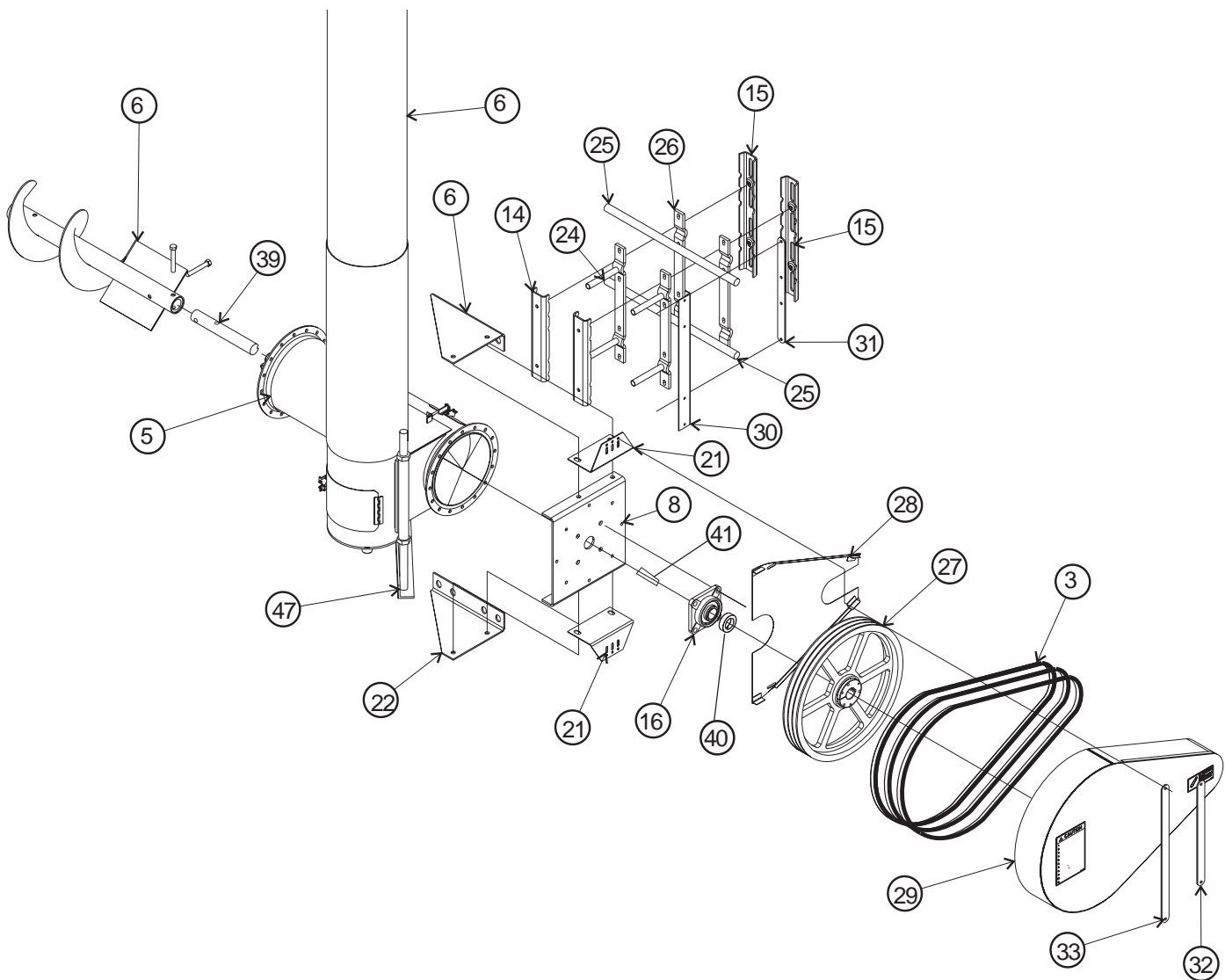

1. Start-up and Break-In

⚠ DANGER

ALWAYS keep ALL guards and shields in place, until all the power is disconnected and locked out.

- A. Make sure all belts are tensioned properly.
- B. Make sure ALL shields are in place and that the belt(s) and pulley(s) are able to move freely.
- C. Double check the assembly instructions to see that all parts have been assembled properly.
- D. During operation of equipment, one person should be in a position to monitor the entire operation.

⚠ DANGER

During the initial start-up and break-in period, the operator should note any unusual vibrations or noises and take the appropriate action.

⚠ CAUTION

Make certain everyone is clear before operating or moving the machine.

- E. The bin well inside the bin should have a control gate. The gate should be closed before start-up and closed before shutdown to allow the machine to clean out.
- F. The controls for the control gate should either pull or push open, depending on the type of well you have. Use the control gate to regulate a flow of less than full capacity until several hundred bushels of grain have been augered to polish the flighting assembly and tube.
- G. Any new screw conveyor or one that has set idle for a season should go through a "break-in" period. This "break-in" consists of running the auger at half capacity until the screw becomes polished and smooth before attempting to run at full capacity. It is recommended that several hundred bushels of grain be augered at partial capacity.

NOTE

Failure of your auger is very likely to occur if it is run at full capacity before the screw has become polished.

NOTE

NEVER operate augers empty for any length of time as excessive wear will result.

- H. Do not stop or start augers under load, especially before the flight and tube become well polished, as this may cause the auger to "lockup". Make sure to use the control gate as a flow control so the vertical auger cannot become plugged.

NOTE

Excessive wear will result if auger is run at speeds in excess of what is recommended.

1. 8" Vertical Commercial Bin Unloading Auger Operating Instructions

- A. **Parts Included:** 16'-6" vertical auger, horizontal tube 24" long with flange, horizontal drive with 2 or 3 belt drive, 2 belt vertical drive with pulleys, "B" belts, motor mount, mounting brackets, belt guard and 3' discharge spout. Your horizontal unloading flight should be ordered separately.
- B. **Capacity:** For cases with high moisture or high capacity requirements, use the next size larger motor. (See Capacity Chart Below.)

MATERIAL	CAPACITY - 8"
Dry Grain	1000-1500
High Moisture	800-1200

- C. **Vertical Drive:** Use a 4.6" motor pulley for recommended auger speed of 536 RPM.
- D. **Horizontal Drive:** Use a 3.5" motor pulley for recommended auger speed of 408 RPM.

NOTE Motor pulleys are NOT furnished with the auger.

- E. **Vertical Horsepower:** Use a 5 H.P. Motor
- F. **Horizontal Horsepower:** Use the horsepower chart below to find the flight length to fit your needs.

8" Horizontal Flights for Vertical Height Unloaders			
Product No.	Bin Dia.	H.P.	Flight Length
GFC82400	24'	3	14' -6" x 7" O.D. Flight
GFC82700	27'	3	16' -0" x 7" O.D. Flight
GFC83000	30'	5	17' -6" x 7" O.D. Flight
GFC83300	33'-34'	5	19' -6" x 7" O.D. Flight
GFC83600	36'	5	20' -6" x 7" O.D. Flight
GFC83800	37'-39'	5	22' -6" x 7" O.D. Flight
GFC84000	40'	5	23' -0" x 7" O.D. Flight
GFC84200	42'	5	24' -0" x 7" O.D. Flight
GFC84800	48'-49'	5	27' -0" x 7" O.D. Flight
GFC85400	54'-55'	5	30' -0" x 7" O.D. Flight
GFC86000	60'	5	33' -0" x 7" O.D. Flight
GFC86300	63'	5	34' -6" x 7" O.D. Flight
GFC86800	68'-69'	7 1/2	37' -6" x 7" O.D. Flight
GFC87200	72'	7 1/2	39' -0" x 7" O.D. Flight
GFC87500	75'	7 1/2	40' -6" x 7" O.D. Flight
GFC87800	78'	10	42' -6" x 7" O.D. Flight
GFC88000	80'	10	44' -6" x 7" O.D. Flight
GFC88200	82'	10	45' -6" x 7" O.D. Flight
GFC89000	90'	10	49' -6" x 7" O.D. Flight
GFC89200	92'	10	50' -6" x 7" O.D. Flight

- G. The horsepower recommendations are for augering reasonably dry grain. High moisture grain (above 15%) will require greater power if maximum capacity is to be maintained. The maximum possible capacity will be less with high moisture grain than with dry grain. Use an electric motor of the correct size that operates at 1750 R. P. M.

⚠ WARNING Electrical controls and wiring should be installed by a qualified electrician. The motor disconnect switches and conductor cables should comply with the National Electrical Code and any local codes which apply. Motor starting control stations should be so located that the operator can see that all personnel are clear of the equipment.

2. 10" Vertical Commercial Bin Unloading Auger Operating Instructions

- A. **Parts Included:** 16'-6" vertical auger, horizontal tube 30" long with flange, horizontal drive with 2 or 3 belt drive, 2 belt vertical drive with pulleys, "B" section belts, motor mount, mounting brackets, belt guard and 3' discharge spout. Your horizontal unloading flight should be ordered separately.
- B. **Capacity:** For cases with high moisture or high capacity requirements, use the next size larger motor. (See Capacity Chart Below.)

MATERIAL	CAPACITY - 10"
Dry Grain	1600-2000
High Moisture	1300-1600

- C. **Vertical Drive:** Use a 4.6" motor pulley for recommended auger speed of 408 RPM.
- D. **Horizontal Drive:** Use a 3.4" motor pulley for recommended auger speed of 323 RPM.

NOTE Motor pulleys are NOT furnished with the auger.

- E. **Vertical Horsepower:** Use a 7-1/2 H.P. Motor
- F. **Horizontal Horsepower:** Use the horsepower chart below to find the flight length to fit your needs.

10" Horizontal Flights for Vertical Height Unloaders			
Product No.	Bin Dia.	H.P.	Flight Length
GFC10240	24'	5	14' -6" x 7" O.D. Flight
GFC10270	27'	5	16' -0" x 7" O.D. Flight
GFC10300	30'	5	17' -6" x 7" O.D. Flight
GFC10330	33'-34'	5	19' -6" x 7" O.D. Flight
GFC10360	36'	7 1/2	20' -6" x 7" O.D. Flight
GFC10380	37'-39'	7 1/2	22' -6" x 7" O.D. Flight
GFC10400	40'	7 1/2	23' -0" x 7" O.D. Flight
GFC10420	42'	7 1/2	24' -0" x 7" O.D. Flight
GFC10480	48'-49'	7 1/2	27' -0" x 7" O.D. Flight
GFC10540	54'-55'	7 1/2	30' -0" x 7" O.D. Flight
GFC10600	60'	10	33' -0" x 7" O.D. Flight
GFC10630	63'	10	34' -6" x 7" O.D. Flight
GFC10680	68'-69'	10	37' -6" x 7" O.D. Flight
GFC10720	72'	10	39' -0" x 7" O.D. Flight
GFC10750	75'	10	40' -6" x 7" O.D. Flight
GFC10780	78'	10	42' -6" x 7" O.D. Flight
GFC10800	80'	15	44' -6" x 7" O.D. Flight
GFC10820	82'	15	45' -6" x 7" O.D. Flight
GFC10900	90'	15	49' -6" x 7" O.D. Flight
GFC10920	92'	15	50' -6" x 7" O.D. Flight

- G. The horsepower recommendations are for augering reasonably dry grain. High moisture grain (above 15%) will require greater power if maximum capacity is to be maintained. The maximum possible capacity will be less with high moisture grain than with dry grain. Use an electric motor of the correct size that operates at 1750 R. P. M.

⚠ WARNING Electrical controls and wiring should be installed by a qualified electrician. The motor disconnect switches and conductor cables should comply with the National Electrical Code and any local codes which apply. Motor starting control stations should be so located that the operator can see that all personnel are clear of the equipment.

3. Power Source

- A. Use electric motors that operate at 1750 R.P.M.
- B. Electric motors and controls should be installed by a qualified electrician and must meet the standards set by the National Electrical Code and all local and state codes.
- C. A magnetic starter should be used to protect your motor when starting and stopping. It should stop the motor in case of power interruption, conductor fault, low voltage, circuit interruption, or motor overload. Then the motor must be restarted manually. Some motors have built-in thermal overload protection. If this type motor is used, use only those with a manual reset.

⚠ WARNING

You should use a Main Power Disconnect Switch capable of being locked only in the OFF position. This should be locked whenever work is being done on the auger.

NOTE

Disconnect power before resetting motor overloads.

⚠ CAUTION

Make sure all electrical motors are grounded.

⚠ WARNING

Reset and motor starting and stopping controls must be located so that the operator has full view of the entire operation.

⚠ DANGER

Shut off power to adjust , service, or clean the machinery.

⚠ DANGER

Keep all safety guards and shields in place.

4. Maintenance

- A. The flange bearings on the head and tail ends of all units should be lubricated on frequent intervals.

⚠ DANGER

Never clean, adjust, or lubricate a machine that is in operation.

1. Normal Shutdown

- A. Make certain that bin well and unloading tubes are empty before stopping the unit.
- B. Disconnect and lockout the power source before leaving the work area.

2. Emergency Shutdown

- A. Know how to shut down the auger in case of an emergency.
- B. Disconnect and lockout the power source.
- C. Close bin well control gates.
- D. Clear out as much grain from the auger and hopper as you can.

NOTE

Never restart when under a full load. Starting unit under load may result in damage to the machine. Such damage is considered abuse of the equipment.

- E. Reconnect and unlock the power source.
- F. Gradually clear the auger until there is no grain or obstructions.

3. Lockout

- A. Always stop and disconnect the power source whenever the operator must leave the work area or for maintenance of the machinery.
- B. Make sure no one can operate the unload auger while the operator is not in the work area.

NOTE

Use the type of main power disconnect switch that is capable of being locked only in the off position.

3. Storage Preparation

- A. Close all wells to discharge tube.
- B. Be sure the unload tube is empty.
- C. Make sure power source is disconnected and locked out.
- D. Check to see that all fasteners are secure.

Problem	Possible Cause	Solution
1. The auger is vibrating.	A. Damage can occur to the auger flighting, causing noise. Damage usually is caused from foreign material being run through the auger.	A1. It may be necessary to remove the flighting for inspection.
	A. Drive belt may be overtightened, putting head stub and flight in a bind.	A1. Loosen the drive belts.
2. Capacity is too low.	A. There may not be enough grain reaching the auger.	A1. Make sure the intake has not bridged over, restricting flow. The flighting at the intake should be covered with grain for maximum capacity.
	B. The auger is moving too slowly.	B1. Check the auger speed. Low capacity will result from speeds slower than recommended.
3. The auger plugs.	A. The auger may be "jamming" because too much grain is reaching the auger.	A1. Use the control gates to decrease the amount of grain the auger is gathering.
	B. The grain may be wet.	B1. If wet grain or other hard-to-move material is being augered, use a larger size motor than recommended for normal use.
	C. The auger may be jammed with foreign material.	C1. Remove any foreign material in the auger.
	D. The motor may be too small or wired incorrectly.	D1. Check wiring or consider using the next larger size motor.

8" PARTS ILLUSTRATION

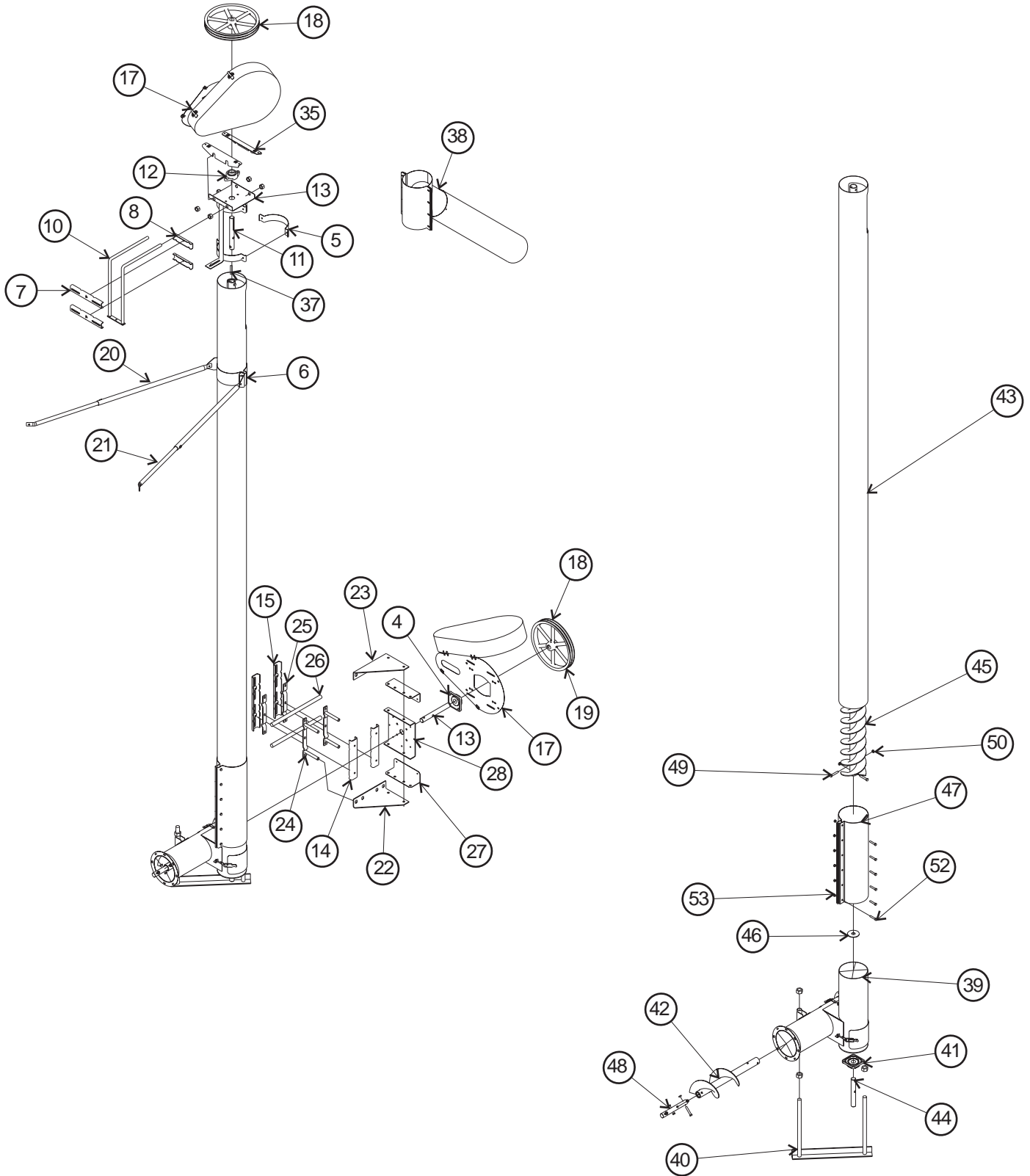

8" PARTS LIST

Ref. No.	Part No.	Description
4	GK1017	1.25" Bore Flange Bearing w/ Lock
5	GK1055	8" x 2" Wide Galvanized Halfband
6	GK1059	8" x 4" Wide Galvanized Halfband - 12 Ga.
7	GK1063	Motor Mount Top Strap
8	GK1064	Motor Mount Bottom Strap
N/S	GK1317	Decals Package
10	GK1327	8" Motor Mount Weldment
11	GK1331	Drive Shaft - 1.25" O.D. x 10.5"
12	GK1330	1.25" Two hole flange bearing
13	GK1329	8" Head Plate Assembly
14	GK1341	Motor Mount Bottom
15	GK1342	Motor Mount Top
N/S	GK1346	Belt V B-57
17	GK1454	Belt Guard Assembly
18	GK1869	Aluminum Sheave - 15" x 1.25" for 2 belts
19	GK2234	Aluminum Sheave - 15" x 1.25" for 3 belts
20	GK1891	Inner Leg Telescoping Tube 32"
21	GK1892	Outer Leg Telescoping Tube 36"
22	GK1897	Left Side Motor Mount
23	GK1898	Right Side Motor Mount
24	GK2108	8" Strap and Rod Assembly
25	GK2109	8" Top Strap
26	GK2110	Motor Mount 1" O.D. x 19" Long
27	GK3096	Belt Guard Mounting Angle Power Head Vertical
28	GK3097	8" Head Plate for Power Head Vertical
N/S	GK3098	8" Bolt Kit
N/S	GK4235	HDW: Mounting Bracket Vertical Double Drive
N/S	Pneg- 1057	Manual Instructions
N/S	Pneg-777	Shortage Claim Sheet
N/S	GK1317	Decal Package: 6-10" Horizontal Drive
35	GK1344	Belt Guard Mounting Angles
36	S-8276	3" Key - 1/4" x 1/4" x 3"
37	S-4513	2" Key - 1/4" x 1/4" x 2"
38	GK1002	Spout
39	GK3090	Verticle Cross Assembly
40	GK3088	Support Stand Assembly
41	GK1017	1-1/4" Bearing 4 Hole
42	GK3087	Head Flight 7" O.D. x 23" Long
43	GK3086	8" O.D. x 14' -5" Unloading Tube
44	GK1884	Tail Stub
45	GK1004-2	Vertical Flight Weldment
46	GK1113	Rubber Washer
47	GK1015	Connecting Band
48	GK1328	Connecting Stub
49	S-7013	7/16" x 14" x 2-1/2" Bolt
50	S-7170	7/16" Deformed Locknut
52	S-7522	3/8" x 16x 2" Zinc Coated Grade 2 HHCS Bolt
53	S-456	3/8" Nut

10" PARTS ILLUSTRATION

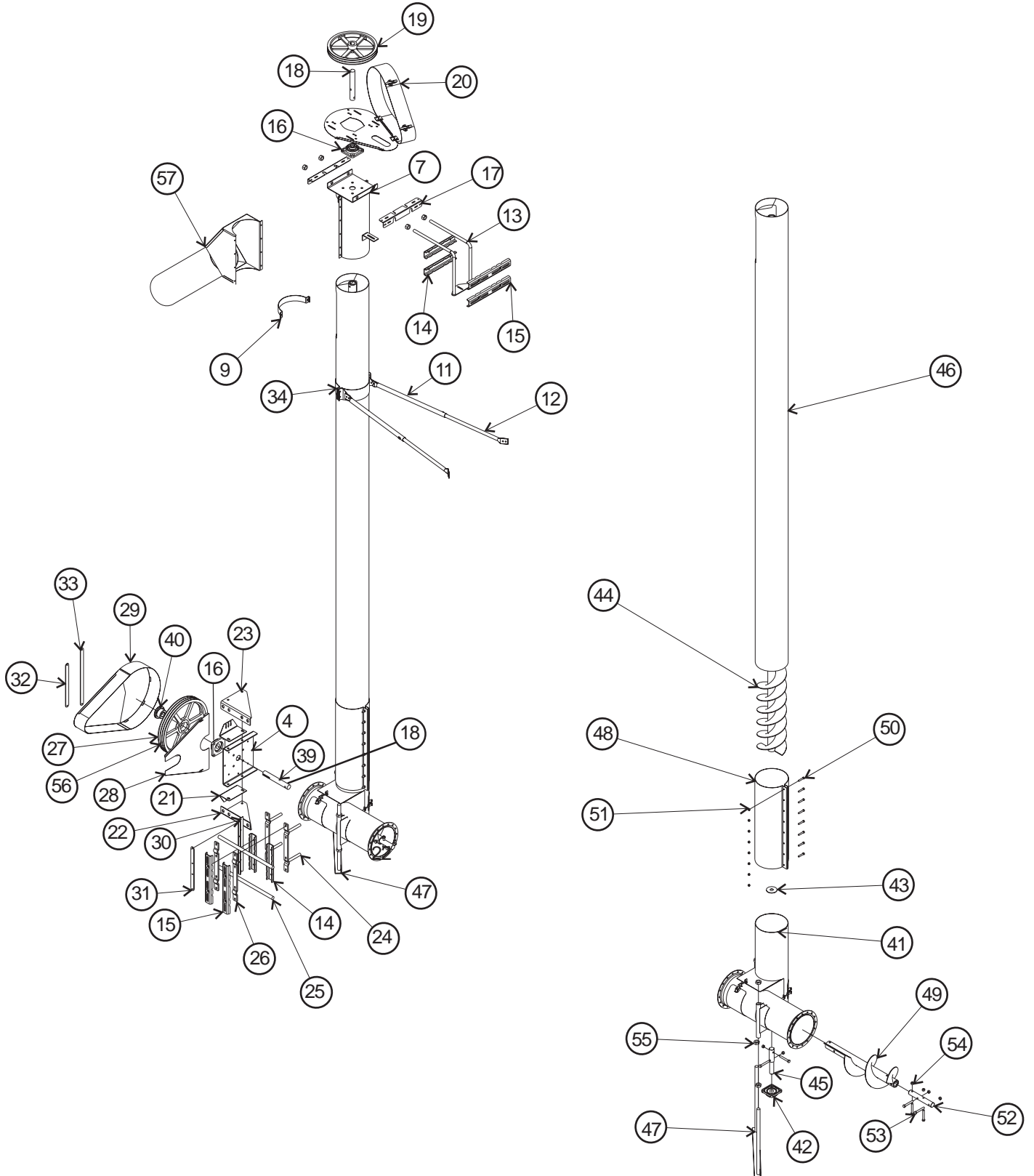

10" PARTS LIST

Ref. No.	Part No.	Description
NIS	GK4235	Bolt Kit for 10" Powerhead Vertical Double Drive Auger
NIS	GK4247	Mounting Bracket Hardware for 10"
7	GK1349	10" Head Plate Assembly
4	GK2561	Head Plate for Direct Belt Drive
9	GK1057	10" x 2" Wide Galvanized Halfband
NIS	GK1317	6" - 10" Horizontal Drive Decal Package
11	GK1028	Telescoping Tube Less Set Screw
12	GK1033	28" Telescoping Tube
13	GK1350	10" Motor Mount Weldment
14	GK1341	Motor Mount Bottom
15	GK1342	Motor Mount Top
16	GK1343	1-1/2" Bearing Flange
17	GK1344	Belt Guard Mounting Angle
18	GK1340	Stub Drive 1.5" O.D. x 10.5"
19	GK1345	Aluminum Sheave - 15" x 1.50" for 2 belts
20	GK1454	Belt Guard Assembly
21	GK2569	Belt Guard Support
22	GK1897	Left Side Motor Mount
23	GK1898	Right Side Motor Mount
24	GK1900	10" Strap and Rod Assembly
25	GK1893	Motor Mount Rod
26	GK1901	Top Strap
27	GK2567	Sheave: 18.4" O.D.w/out Bushing Z-Belt
28	GK2568	Belt Guard Back Weldment
29	GK2565	Belt Guard Front
30	GK2017	Belt Guard Mounting Angle
31	GK2018	Clamp Bar for Mounting Angle
32	GK2019	Clamp Bar for Belt Guard
33	GK2564	Clamp Bar for Belt Guard
34	GK1301	10" x 4" Wide Galvanized Halfband
NIS	PNEG-1057	8"-10" Commercial Vertical Manual Instructions
NIS	PNEG-777	Shortage Claim Sheet Form
NIS	GK1346	Belt V B -57
NIS	GK2566	Belt V B-71
39	GK2562	1.5" O.D. x 9.5" Long Drive Stub
40	GK4248	1-1/2" SK Bushing
41	GK1882	Vertical Cross Assembly
42	GK1017	1-1/4" 4 Hole Bearing (Peer)
43	GK1113	Rubber Washer
44	GK1876	9" O.D. x 16-1/2" Long Vertical Unloading Flight
45	GK4886	1-1/4" to 1-1/2" x 9" Tail Stub
46	GK1877	10" O.D. -14' Unloading Tube
47	GK1879	Support Stand Assembly
48	1883	Connecting Band
49	2563	29" Head Flight 9" O.D. (Direct Belt Drive)
50	S-7522	Bolt HHCS 3/8" x 16" x 2" Zinc Grade 2
51	S-456	3/8" - 16 Nut
52	GK1137	1.5 x 9.5 Stub Shaft
53	S-8314	Bolt, HHCS 1/2"-13 x 3-1/2" YDP Grade 8
54	S-8315	Lock Nut 1/2"-13 ZN GRC Prevailing Torque
55	S-240	Hex Nut 1 - Zinc Grade 5
NIS	S-1054	Split Lock Washer 3/8" Med. Zinc
56	GK2570	Sheave: 18.4" O.D.w/out Bushing 3-Belt
57	GK1875	Spout
NIS	S-7079	U-Bolt 5/16 - 18 x 1-3/4 IW PL
NIS	S-7116	Bolt HHCS 1/4-20 x 5-1/2"



Limited Warranty

The GSI Group, LLC. ("GSI") warrants products which it manufactures to be free of defects in materials and workmanship under normal usage and conditions for a period of 12 months after sale to the original end-user or if a foreign sale, 14 months from arrival at port of discharge, whichever is earlier. The end-user's sole remedy (and GSI's only obligation) is to repair or replace, at GSI's option and expense, products that in GSI's judgment, contain a material defect in materials or workmanship. Expenses incurred by or on behalf of the end-user without prior written authorization from the GSI Warranty Group shall be the sole responsibility of the end-user.

Warranty Extensions: The Limited Warranty period is extended for the following products:

	Product	Warranty Period
AP Fans and Flooring	Performer Series Direct Drive Fan Motor	3 Years
	All Fiberglass Housings	Lifetime
	All Fiberglass Propellers	Lifetime
Cumberland Feeding/Watering Systems	Feeder System Pan Assemblies	5 Years **
	Feed Tubes (1.75" & 2.00")	10 Years *
	Centerless Augers	10 Years *
	Watering Nipples	10 Years *
Grain Systems	Grain Bin Structural Design	5 Years
Grain Systems Farm Fans Zimmerman	Portable & Tower Dryers	2 Years
	Portable & Tower Dryer Frames and Internal Infrastructure †	5 Years

* Warranty prorated from list price:
 0 to 3 years – no cost to end-user
 3 to 5 years – end-user pays 25%
 5 to 7 years – end-user pays 50%
 7 to 10 years – end user pays 75%

** Warranty prorated from list price:
 0 to 3 years – no cost to end-user
 3 to 5 years – end-user pays 50%

† Motors, burner components and moving parts not included. Portable Dryer screens included. Tower Dryer screens not included.

GSI further warrants that the portable and tower dryer frame and basket, excluding all auger and auger drive components, shall be free from defects in materials for a period of time beginning on the twelfth (12th) month from the date of purchase and continuing until the sixtieth (60th) month from the date of purchase (extended warranty period). During the extended warranty period, GSI will replace the frame or basket components that prove to be defective under normal conditions of use without charge, excluding the labor, transportation, and/or shipping costs incurred in the performance of this extended warranty.

Conditions and Limitations:

THERE ARE NO WARRANTIES THAT EXTEND BEYOND THE LIMITED WARRANTY DESCRIPTION SET FORTH ABOVE. SPECIFICALLY, GSI MAKES NO FURTHER WARRANTY OF ANY KIND, EXPRESS OR IMPLIED, INCLUDING, WITHOUT LIMITATION, WARRANTIES OF MERCHANTABILITY OR FITNESS FOR A PARTICULAR PURPOSE OR USE IN CONNECTION WITH: (i) PRODUCT MANUFACTURED OR SOLD BY GSI OR (ii) ANY ADVICE, INSTRUCTION, RECOMMENDATION OR SUGGESTION PROVIDED BY AN AGENT, REPRESENTATIVE OR EMPLOYEE OF GSI REGARDING OR RELATED TO THE CONFIGURATION, INSTALLATION, LAYOUT, SUITABILITY FOR A PARTICULAR PURPOSE, OR DESIGN OF SUCH PRODUCTS.

GSI shall not be liable for any direct, indirect, incidental or consequential damages, including, without limitation, loss of anticipated profits or benefits. The sole and exclusive remedy is set forth in the Limited Warranty, which shall not exceed the amount paid for the product purchased. This warranty is not transferable and applies only to the original end-user. GSI shall have no obligation or responsibility for any representations or warranties made by or on behalf of any dealer, agent or distributor.

GSI assumes no responsibility for claims resulting from construction defects or unauthorized modifications to products which it manufactured. Modifications to products not specifically delineated in the manual accompanying the equipment at initial sale will void the Limited Warranty.

This Limited Warranty shall not extend to products or parts which have been damaged by negligent use, misuse, alteration, accident or which have been improperly/inadequately maintained. This Limited Warranty extends solely to products manufactured by GSI.

Prior to installation, the end-user has the responsibility to comply with federal, state and local codes which apply to the location and installation of products manufactured or sold by GSI.

This Equipment shall be installed in accordance with the current installation codes and applicable regulations which should be carefully followed in all cases. Authorities having jurisdiction should be consulted before installation occurs.

GRAINKING

**1004 East Illinois Street
Assumption, IL 62510
Ph: (217) 226-4421**
