

8" and 10" Commercial Vertical Bin Unload Auger

Assembly and Operation Manual

PNEG-1057

Version: 3.1

Date: 07-20-16



PNEG-1057

Personnel operating or working around this equipment should read this manual. This manual must be delivered with equipment to its owner. Failure to read this manual and its safety instructions is a misuse of the equipment. Any misuse of the equipment may void the warranty.

Contents

Chapter 1 Introduction	4
General Information	4
Capacity	4
Chapter 2 Safety	5
Safety Guidelines	5
Cautionary Symbols Definitions	6
Safety Cautions	7
Safety Sign-Off Sheet	10
Chapter 3 Safety Decals	11
Chapter 4 8" Vertical Assembly Instructions	14
Motor Mount Rod to Head Plate Assembly	14
Tube Assembly	14
Attaching Vertical Section to Bin	16
Attaching Motor Mount to Horizontal Section	18
Chapter 5 10" Vertical Assembly Instructions	20
Motor Mount Rod to Head Plate Assembly	20
Tube Assembly	20
Attaching Vertical Section to Bin	22
Attaching Horizontal Motor Mount (Direct Belt Drive)	24
Chapter 6 Start-Up	26
Start-Up and Break-In	26
Chapter 7 Operation and Maintenance	27
8" Vertical Commercial Bin Unloading Auger Operating Instructions	27
10" Vertical Commercial Bin Unloading Auger Operating Instructions	28
Power Source	29
Maintenance	29
Chapter 8 Shut Down	30
Normal Shut Down	30
Emergency Shut Down	30
Lock Out	30
Storage Preparation	30
Chapter 9 Troubleshooting	31
Chapter 10 Parts List	33
8" Commercial Vertical Bin Unload Auger Parts	34
10" Commercial Vertical Bin Unload Auger Parts	36
Chapter 11 Warranty	38

1. Introduction

General Information

1. We reserve the right to improve our product whenever possible and practical to do so. We reserve the right to change, improve and modify products at any time without obligation to make changes, improvements and modifications on equipment sold previously.
2. The 8" and 10" Commercial Vertical Bin Unload Augers have been designed and manufactured to give years of dependable service. The care and maintenance of this machine will affect the satisfaction and service obtained. By observing the instructions and suggestions we have recommended, the owner should receive competent service for many years. If additional information or assistance should be required, please contact the factory or the local dealer.
3. When receiving merchandise, it is important to check both the quantity of parts and their descriptions with the packing list enclosed within each package. All claims for freight damage or shortage must be made by the consignee within ten (10) days from the date of the occurrence of freight damage. The consignee should accept the shipment after noting the damage or loss.

Capacity

1. The capacities may vary greatly under varying conditions. The following factors play a role in the performance of the auger:
 - Speed
 - Angle of operation
 - Moisture content
 - Amounts of foreign matter
 - Different materials
 - Methods of feeding
2. For example, a twenty-five percent (25%) moisture could cut capacity by as much as 40% under some conditions.

Safety Guidelines

Safety guidelines are general-to-specific safety rules that must be followed at all times. This manual is written to help you understand safe operating procedures and problems that can be encountered by the operator and other personnel when using this equipment. Save these safety guidelines for future reference.

As owner or operator, you are responsible for understanding the requirements, hazards, and precautions that exist and to inform others as required. Unqualified persons must stay out of the work area at all times.

Alterations must not be made to the equipment. Alterations can produce dangerous situations resulting in **SERIOUS INJURY** or **DEATH**.

This equipment must be installed in accordance with the current installation codes and applicable regulations, which must be carefully followed in all cases. Authorities having jurisdiction must be consulted before installations are made.

When necessary, you must consider the installation location relative to electrical, fuel and water utilities.

Personnel operating or working around equipment must read this manual. This manual must be delivered with equipment to its owner. Failure to read this manual and its safety instructions is a misuse of the equipment.

ST-0001-3

Cautionary Symbols Definitions

Cautionary symbols appear in this manual and on product decals. The symbols alert the user of potential safety hazards, prohibited activities and mandatory actions. To help you recognize this information, we use the symbols that are defined below.



This symbol indicates an imminently hazardous situation which, if not avoided, **will result in serious injury or death.**



This symbol indicates a potentially hazardous situation which, if not avoided, **can result in serious injury or death.**



This symbol indicates a potentially hazardous situation which, if not avoided, **can result in minor or moderate injury.**



This symbol is used to address practices not related to personal injury.



This symbol indicates a general hazard.



This symbol indicates a prohibited activity.

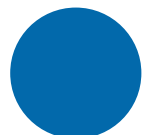

This symbol indicates a mandatory action.

ST-0005-2

Safety Cautions

Use Personal Protective Equipment

- Use appropriate personal protective equipment:

Eye Protection



Respiratory Protection



Foot Protection



Hearing Protection



Head Protection



Fall Protection



Hand Protection



- Wear clothing appropriate to the job.
- Remove all jewelry.
- Tie long hair up and back.

ST-0004-1

Follow Safety Instructions

- Carefully read all safety messages in this manual and safety signs on your machine. Keep signs in good condition. Replace missing or damaged safety signs. Be sure new equipment components and repair parts include the current safety signs. Replacement safety signs are available from the manufacturer.
- Learn how to operate the machine and how to use controls properly. Do not let anyone operate without instruction.
- If you do not understand any part of this manual or need assistance, contact your dealer.



ST-0002-1

2. Safety

Maintain Equipment and Work Area

- Understand service procedures before doing work. Keep area clean and dry.
- Never service equipment while it is operating. Keep hands, feet, and clothing away from moving parts
- Keep your equipment in proper working condition. Replace worn or broken parts immediately.



ST-0003-1

Operate Motor Properly

- All electrical connections must be made in accordance with applicable local codes (National Electrical Code for the US, Canadian Electric Code, or EN60204 along with applicable European Directives for Europe). Make sure equipment and bins are properly grounded.
- Lock-out power before resetting motor overloads.
- Do not repetitively stop and start the drive in order to free a plugged condition. Jogging the drive in this manner can damage the equipment and drive components.



ST-0009-3

Rotating Auger Hazard

- Keep clear of rotating augers and moving parts.
- Do not remove or modify guards or covers.
- Lock-out power source before making adjustments, cleaning, or maintaining equipment.
- Failure to follow these precautions will result in serious injury or death.



ST-0037-1

Stay Clear of Hoisted Equipment

- Always use proper lifting or hoisting equipment when assembling or disassembling equipment.
- Do not walk or stand under hoisted equipment.
- Always use sturdy and stable supports when needed for installation. Not following these safety precautions creates the risk of falling equipment, which can crush personnel and cause serious injury or death.



ST-0047-1

Stay Clear of Rotating Parts

- Do not enter the bin while the equipment is in operation.
- Entanglement in rotating augers will cause serious injury or death.
- Keep all guards and covers in place at all times.
- Lock-out power source before making adjustments, cleaning, or maintaining equipment.



ST-0008-2

Use Unload Equipment Properly

- Do not operate this equipment alone. Make sure someone nearby is aware of the proper shut down sequence in the event of an emergency.
- Do not allow any person intoxicated or under the influence of drugs to operate this equipment. All operators must be adequately rested and prepared to perform all functions of operating the equipment.
- Do not start equipment until all persons are clear of the work area and safety guards are in place.
- Do not allow anyone inside a bin, truck, or wagon which is being unloaded by an auger. Flowing grain can trap and suffocate in seconds.
- Use ample overhead lighting after sunset to light the work area.
- Always use caution to not hit the auger when positioning the load.
- Do not leave equipment operating while unattended.
- Be aware of pinch points, which can trap or catch objects and cause injury.
- Be sure all equipment is locked in position before operating.
- Always lock out all power sources to the equipment when unloading is finished.



ST-0051-1

The figure *below* shows the location of the decals and safety signs which should appear on the Commercial Vertical Bin Unload Auger. Samples and explanations of these decals are shown *on Pages 12 and 13*.

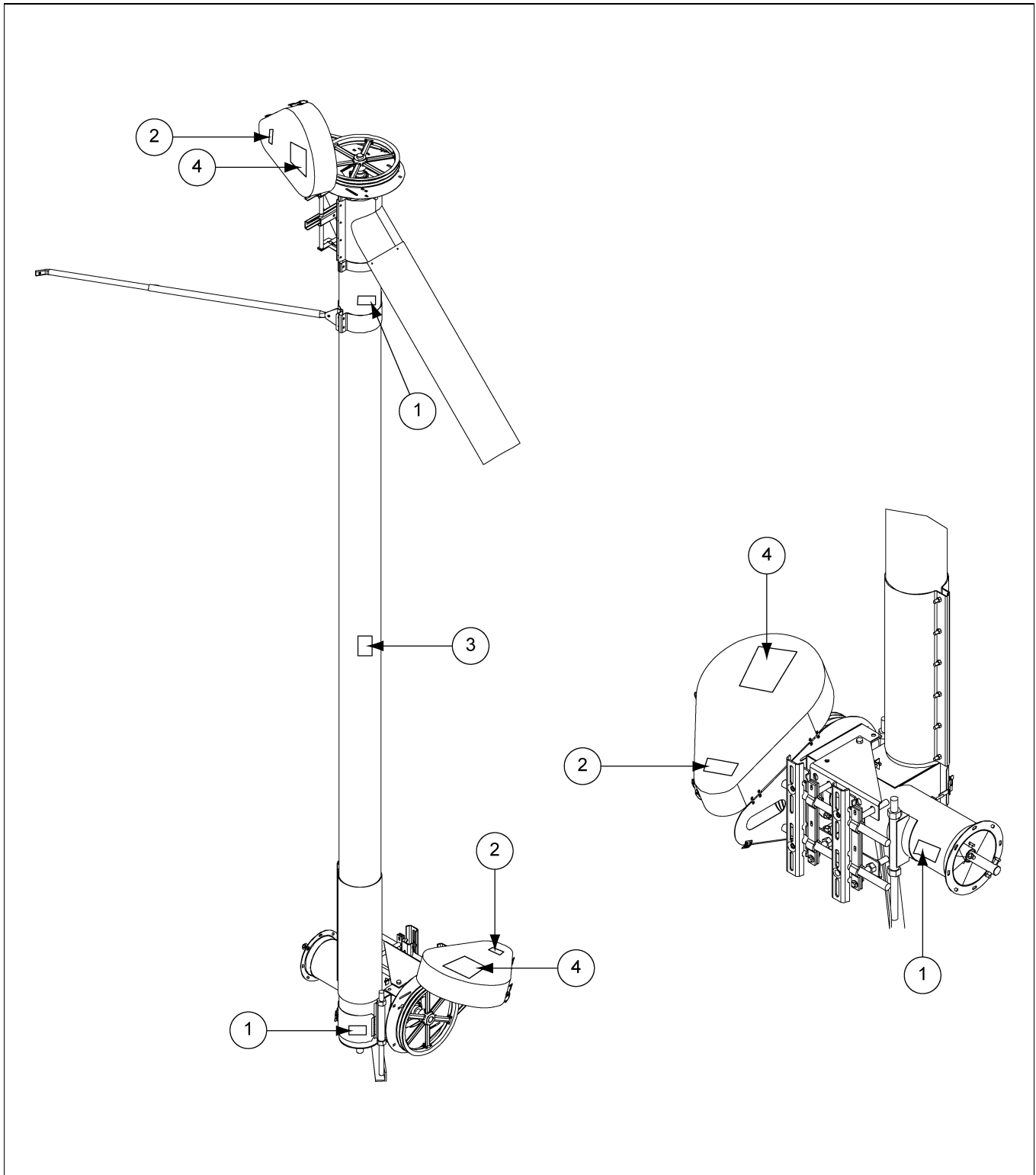

NOTE: Please remember safety signs provide important safety information for people working near bin unloading equipment that is in operation. Any safety signs that are worn, missing, illegible or painted over should be replaced immediately. Obtain FREE replacements by contacting your dealer.

3. Safety Decals

The safety decals [Chart below](#) lists all the safety decals that should be included with the auger. Inspect all decals and replace any that are illegible, worn or missing. Contact the dealer or the manufacturer to order replacement decals.

Ref #	Part #	Description	Size	Qty
1	DC-1381	Danger - Shear Point (Auger)	4-1/2" x 2"	1
2	DC-995	Warning - Shear Point (Belt)	4-1/2" x 2"	1
3	DC-1234	Caution	2-1/4" x 2-3/4"	1
4	DC-1379	Notice	5-1/8" x 7-3/8"	1



! DANGER

SHEAR POINT
Keep clear of rotating auger and moving parts.
Do not remove or modify guards. Disconnect and lock out power before servicing.
Failure to do so will result in serious **INJURY** or **DEATH**.

GSI Group 217-226-4421 DC-1381

1



! WARNING

SHEAR POINT
Keep hands clear of moving parts. Do not operate with guard removed. Disconnect and lockout power before servicing.

GSI Group Inc. 217-226-4421 DC-995

2

NOTICE

FAILURE TO PROPERLY SELECT, INSTALL OR MAINTAIN AN AUGER, ITS DRIVE OR OTHER COMPONENTS CAN RESULT IN DANGEROUS OPERATION.

THIS EQUIPMENT IF IMPROPERLY SELECTED, INSTALLED OR MAINTAINED MAY FAIL AND COULD RESULT IN SERIOUS INJURY OR PROPERTY DAMAGE.

CHECK PRODUCT LITERATURE AND EQUIPMENT MANUFACTURER'S LITERATURE OR CALL THE FACTORY FOR FURTHER INFORMATION.

GSI Group 217-226-4421 DC-1234

3

NOTICE

1. Read and understand the operator's manual and all safety instructions.
2. Do not operate while under the influence of drugs or alcohol.
3. Do not operate unless all safety equipment, switches, guards, and shields are securely in place and operational.
4. Allow only trained authorized personnel in the operating area.
5. Any electrical wiring or service work must be performed by a qualified electrician. It must meet all state and local electrical codes.
6. Do not allow children in the area of operation.
7. Keep hands, feet, & clothing away from moving parts.
8. Disconnect and lockout power before making any adjustments or performing any service work.
9. Disconnect power prior to resetting any motor overload.
10. Make certain all electric motors are grounded.
11. Replace all worn or damaged labels immediately.

GSI Group Inc. 217-226-4421 DC-1379

4

- A. DANGER Sign No. DC-1395 was supplied with the bin unloading equipment. This safety sign should be applied to the side of the bin near the bin opening, so it will be viewed by people entering into the bin storage building. Do not cover any safety signs or any other signs that are already there.
- B. If the safety sign location suggested is not in full view because of equipment modifications, other equipment in the area or any reason, then locate the safety sign in a more suitable location.
- C. Be certain the surface is clean, dry and free of dirt and oil. Peel paper backing from decals and stick into place. The adhesive backing will bond on contact.

NOTE: *Please remember, safety signs provide important safety information for people working near bin unloading equipment that is in operation.*

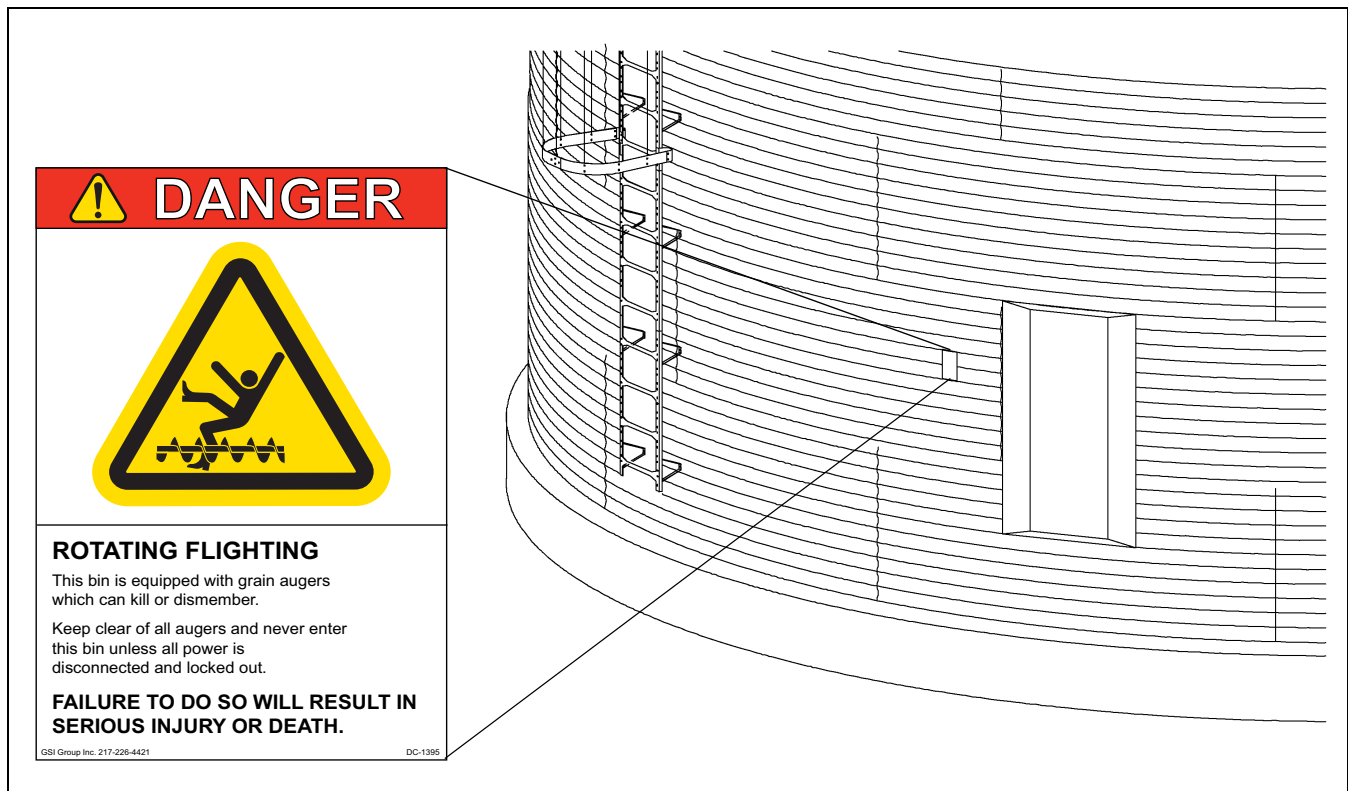

NOTE: *If the Safety Sign cannot be easily read for any reason or has been painted over, replace it immediately. Additional Safety Signs may be obtained free of charge from your dealer, distributor or ordered from the factory.*

Order SAFETY SIGN NO. DC-1395

4. 8" Vertical Assembly Instructions

Motor Mount Rod to Head Plate Assembly

1. Screw one 3/4" hex head nut to the top of each motor mount rod (G).
2. Slide the motor mount rods (G) through the head plate assembly (H).
3. Line up slot on the plate end of the motor mount rods (G) with the slot on the head plate assembly (H). Fasten them together using 5/16" carriage bolt, a flat washer and a nut.
4. Attach a 3/4" hex head nut onto the bottom of each motor mount rod. Tighten until nut rests against the head plate assembly (H).
5. Adjust top 3/4" hex head nuts down until they rests against the top of the head plate assembly (H).

Tube Assembly

1. Connect the 2 hole flange bearing (I) to head plate assembly (H) using two (2) 7/16" x 1-1/4" bolts with lock nuts.
2. Loosen the top and bottom nuts on the head plate assembly (H) to allow the belt guard mounting angles (M) to slide onto the motor mount rods (G). Once the angles are in place tighten nuts to keep rods in position.
3. Connect head drive shaft (J) to flight using two (2) 7/16" x 2-1/4" (grade 5) bolts with lock nuts.
4. Slide head plate assembly (H) over discharge end of tube and tighten the half band clamps (C) using four (4) 5/16" x 1-1/2" bolts with nuts. Slip bearing lock collar (not shown) over head drive stub.
5. Fasten belt guard (K) to top mounting angle (M) using two (2) 5/16" x 3/4" carriage bolts with flat washers, lock washers and nuts.

NOTE: *Leave carriage bolts loose until later.*

6. Place head drive shaft (J) through head bearing with enough extended to mount pulley (L) with key (N). Tighten lock collar on bearing and tighten set screws in pulley
7. Install motor and pulley onto motor mount. (**Motor and pulley are not included.**) Install belts (A) and tighten by adjusting motor height by using the four (4) 3/4" nuts on the rods.
8. Close door on belt guard and latch.
9. Secure 45° discharge spout (D) over the discharge opening using the head plate assembly and eight (8) 5/16" x 1-1/2" long bolts with nuts.

Tube Assembly (Continued)

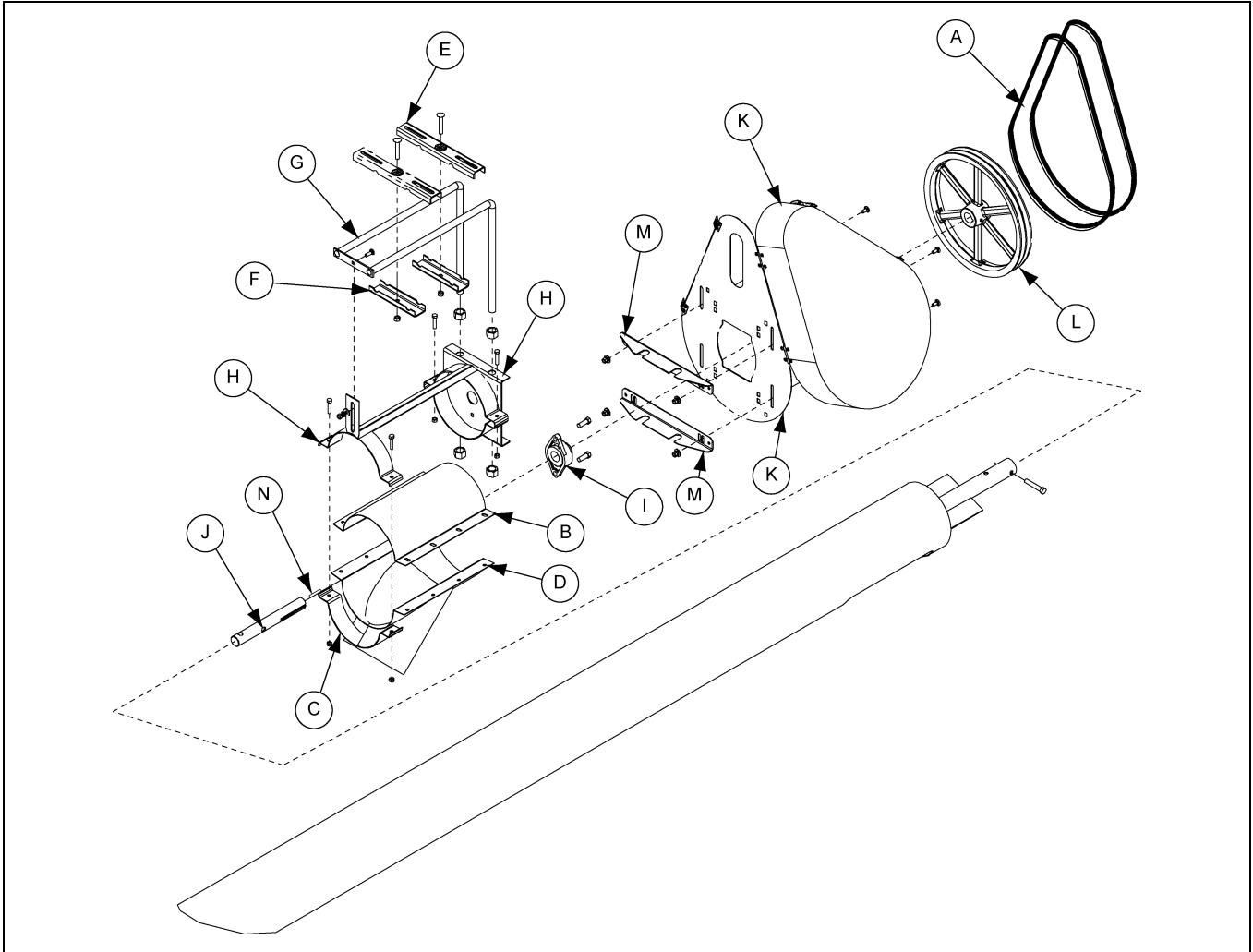

Figure 4A 8" Vertical Tube Assembly

Ref #	Description	Ref #	Description
A	Belt (57")	H	Head Plate Assembly
B	Half Band	I	Flange Bearing
C	Half Band Clamp	J	Head Drive Shaft
D	45° Discharge Spout	K	Belt Guard
E	Motor Mount Top Strap	L	Mount Pulley
F	Motor Mount Bottom Strap	M	Mounting Angle
G	Motor Mount Rod	N	Key



Lock out all power sources while installing or maintaining equipment.



Keep all safety devices and shields in place at all times until power source is locked out.

4. 8" Vertical Assembly Instructions

Attaching Vertical Section to Bin

1. Slide bin unloading flight into bin well and unloading tube (which should already be installed in bin.) The unloading flight for larger bin sizes may need to be bolted together. Use bolts provided in connecting stubs located at the end of the tail flights. *See Chart below* to determine the flight length for the bin size.
2. Bolt unloading flight to short horizontal flight (Ref #B, *on Page 19*) using four (4) 7/16" x 2-3/4" long (grade 5) bolts and lock nuts.
3. Bolt flange on horizontal tube of vertical unloader to the flange of the bin unloader tube with vertical auger in vertical position. Use eight (8) 5/16" x 1" long bolts, lock washers and nuts.

8" Flight Chart

Product #	Bin Diameter	Part #	Description
GFC82400	24'	GK1799	14'-6" x 7" O.D. Flight
GFC82700	27'	GK1800	16'-0" x 7" O.D. Flight
GFC83000	30'	GK1801	17'-6" x 7" O.D. Flight
GFC83300	33'-34'	GK1802	19'-6" x 7" O.D. Flight
GFC83600	36'	GK1803	20'-6" x 7" O.D. Flight
GFC83800	37'-39'	GK1804	22'-6" x 7" O.D. Flight
GFC84000	40'	GK1805	23'-0" x 7" O.D. Flight
GFC84200	42'	GK1806	24'-0" x 7" O.D. Flight
GFC84800	48'-49'	GK1808 GK1807	20'-0" x 7" O.D. Flight (Head) 7'-0" x 7" O.D. Flight (Tail)
GFC85400	54'-55'	GK1808 GK1809	20'-0" x 7" O.D. Flight (Head) 10'-0" x 7" O.D. Flight (Tail)
GFC86000	60'	GK1808 GK1810	20'-0" x 7" O.D. Flight (Head) 13'-0" x 7" O.D. Flight (Tail)
GFC86300	63'	GK1808 GK1811	20'-0" x 7" O.D. Flight (Head) 14'-6" x 7" O.D. Flight (Tail)
GFC86800	68'-69'	GK1808 GK1812	20'-0" x 7" O.D. Flight (Head) 17'-0" x 7" O.D. Flight (Tail)
GFC87200	72'	GK1808 GK1813	20'-0" x 7" O.D. Flight (Head) 19'-0" x 7" O.D. Flight (Tail)
GFC87500	75'	GK1808 GK1814	20'-0" x 7" O.D. Flight (Head) 20'-6" x 7" O.D. Flight (Tail)
GFC87800	78'	GK1808 GK1815	20'-0" x 7" O.D. Flight (Head) 22'-6" x 7" O.D. Flight (Tail)
GFC88000	80'	GK1808 GK1130 GK1821	20'-0" x 7" O.D. Flight (Head) 20'-0" x 7" O.D. Flight (Middle) 4'-6" x 7" O.D. Flight (Tail)
GFC88200	82'	GK1808 GK1130 GK1823	20'-0" x 7" O.D. Flight (Head) 20'-0" x 7" O.D. Flight (Middle) 5'-6" x 7" O.D. Flight (Tail)
GFC89000	90'	GK1808 GK1130 GK1824	20'-0" x 7" O.D. Flight (Head) 20'-0" x 7" O.D. Flight (Middle) 9'-6" x 7" O.D. Flight (Tail)
GFC89200	92'	GK1808 GK1130 GK1825	20'-0" x 7" O.D. Flight (Head) 20'-0" x 7" O.D. Flight (Middle) 10'-6" x 7" O.D. Flight (Tail)

Attaching Vertical Section to Bin (Continued)

4. Adjust stand (Ref #Q, [on Page 19](#)) so it holds the weight of the vertical auger.
5. Attach the support brackets and half bands to the top half of the vertical tube by inserting the 5/16" U-bolt (D) through the support brackets (E) and half bands (F) and fasten together using four (4) 5/16" nylon lock nuts.
6. Attach lower telescoping tube sections (C) to the ears on the support brackets (E) using two (2) 3/8" x 3/4" bolts with lock nuts.
7. Slide the upper telescoping tube sections (A) into the lower tube sections (C). Attach upper tubes to the bin wall.
8. Secure the upper telescoping tubes to the lower telescoping tubes by tightening the square head set screw (B).

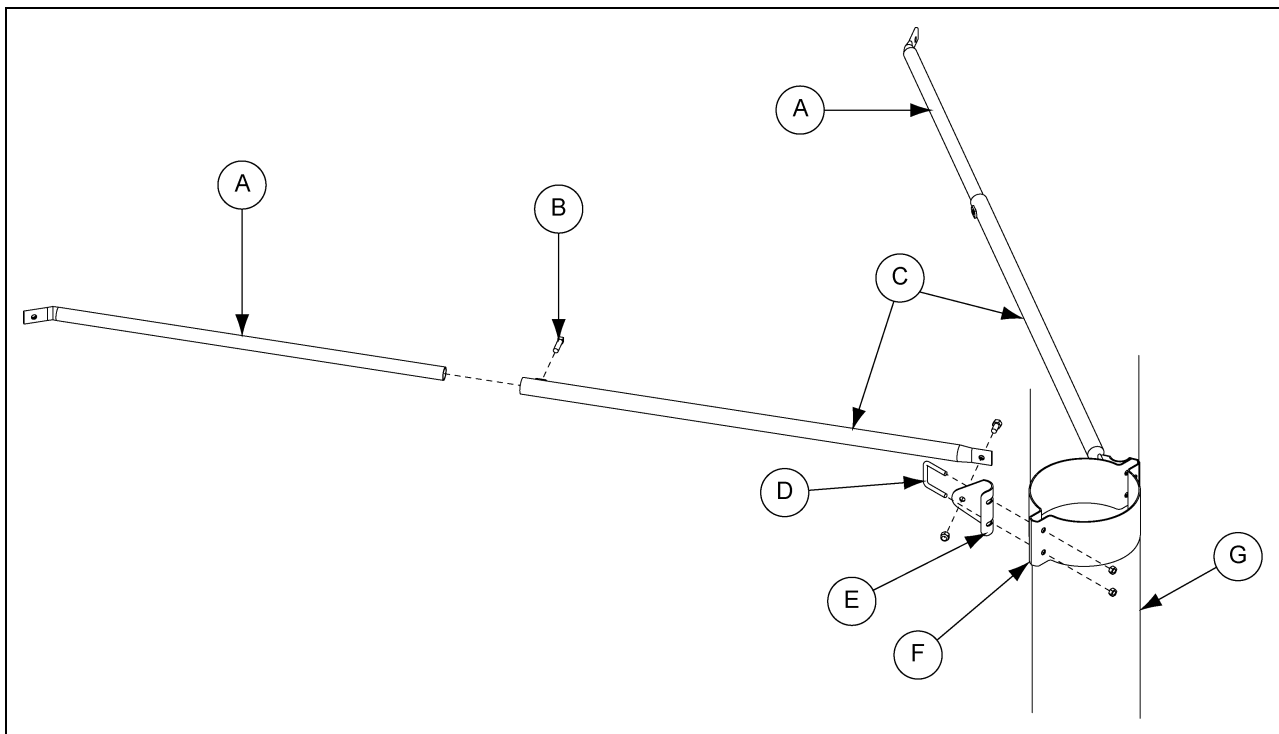

Figure 4B

Ref #	Description
A	Upper Telescoping Tube
B	Square Head Set Screw
C	Lower Tube
D	U-Bolt
E	Support Bracket
F	Half Band
G	Bin Wall

4. 8" Vertical Assembly Instructions

Attaching Motor Mount to Horizontal Section

1. First, connect the head stub shaft (D) to the short flight (B) using two (2) 7/16" x 2-3/4" (grade 5) bolts with lock nuts.
2. Connect the 4-hole flange bearing with lock collar (C) and the head plate (O) together using four (4) 7/16" x 1-1/4" bolts with lock nuts.
3. Attach the head plate (O) to the tube flange using eight (8) 5/16" x 1" bolts with flat washers, lock washers and nuts.
4. Connect side plates (I and J) to head plate (O) using four (4) 1/2" x 1" bolts with lock washers and nuts. Also, at the same time attach the top and bottom belt guard brackets (N) using the same bolts.
5. Spin a 3/4" nut on the threaded rods of each strap and rod assembly (K). Insert threaded rods through holes in side plates (I and J) and add four (4) more 3/4" nuts. Leave only finger tight until later.
6. Place rods (M) in strap and rod assemblies (K) and secure with top straps (L) using 3/8" x 1-1/2" bolts with two (2) flat washers and one nut on each bolt.
7. Position motor mount straps (F) and clips (E) and secure to rod (M) using four (4) 3/8" x 3" long carriage bolts with nuts. Leave only finger tight until motor is installed and adjusted.
8. Attach belt guard (G) to belt guard mounting angles (N) using four (4) 5/16" x 3/4" carriage bolts with flat washers and nuts.
9. Slide bearing lock collar (C) over head stub shaft (D). Leave enough stub exposed to mount pulley (H) on stub with drive key (P). Tighten bearing lock collar next to bearing and tighten set screws in pulley.
10. Install pulley on head stub shaft and mount motor on strap (F). **(Motor and pulley not furnished.)** Install belts (A) and align pulleys. Tighten motor to straps (F). Adjust motors along the tube and tighten with 3/8" x 3" carriage bolts.
11. After everything has been adjusted correctly, go back and tighten all nuts and bolts.

Attaching Motor Mount to Horizontal Section (Continued)

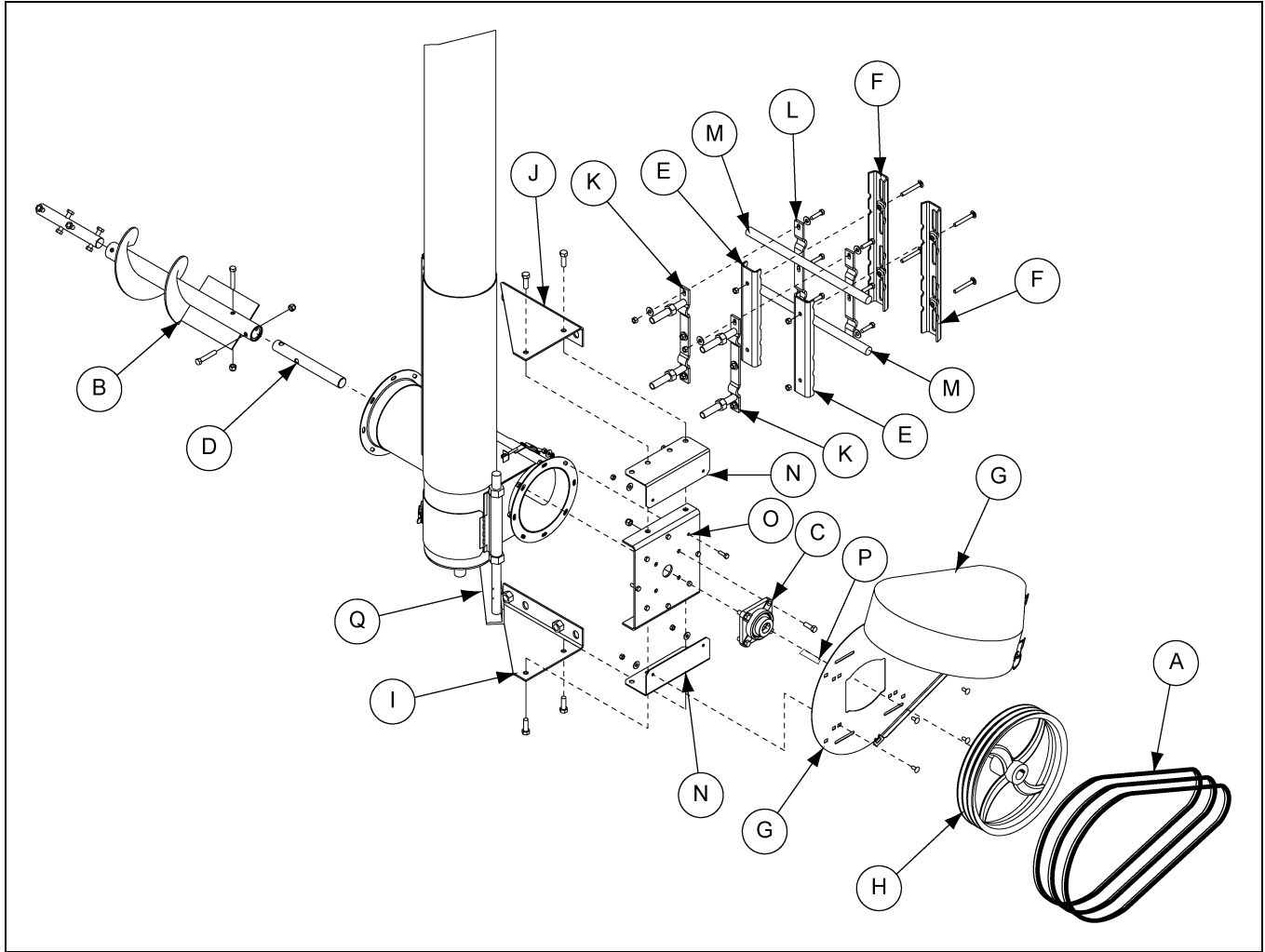

Figure 4C

Ref #	Description
A	Belt (71")
B	Short Flight
C	Lock Collar
D	Head Stub Shaft
E	Clips
F	Motor Mount Straps
G	Belt Guard
H	Mount Pulley

Ref #	Description
I and J	Side Plates
K	Rod Assembly
L	Top Straps
M	Rod
N	Belt Guard Mounting Angle
O	Head Plate
P	Drive Key
Q	Stand

5. 10" Vertical Assembly Instructions

Motor Mount Rod to Head Plate Assembly

1. Screw one 7/8" hex head nut to the top of each motor mount rod (E).
2. Slide the motor mount rods through the head plate assembly.
3. Line up slot on the plate end of the motor mount rods (E) with the slot on the head plate assembly (C). Fasten them together using 3/8" carriage bolt, a split flat washer and a nut.
4. Attach a 7/8" hex head nut onto the bottom of each motor mount rod. Tighten until nut rests against the head plate assembly (C).
5. Adjust top 7/8" hex head nuts down until they rests against the top of the head plate assembly (C).

Tube Assembly

1. Connect the 4-hole flange bearing (H) to head plate assembly (C) using four (4) 1/2" x 1-1/2" bolts with lock nuts.
2. Loosen the top and bottom nuts on the head plate assembly (C) to allow the belt guard mounting angles (I) to slide onto the motor mount rods (E). Once the angles are in place tighten nuts to keep rods in position.
3. Connect head drive stub shaft (J) to flight using two (2) 1/2" x 3-1/2" (grade 5) bolts with lock nuts.
4. Slide head plate assembly (C) over discharge end of tube and tighten the half band clamps (D) using four (4) 5/16" x 1-3/4" bolts with nuts. Slip bearing lock collar (not shown) over head drive stub.
5. Fasten belt guard (L) to top mounting angle (I) using two (2) 5/16" x 3/4" carriage bolts with flat washers, lock washers and nuts.

NOTE: *Leave carriage bolts loose until later.*

6. Place head drive stub shaft (J) through head bearing with enough extended to mount pulley (K) with key (B). Tighten bearing with lock collar and tighten set screws in pulley.
7. Install motor and pulley onto motor mount. **(Motor and pulley are not included.)** Install belts (A) and tighten by adjusting motor height by using the four (4) 3/4" nuts on the rods.
8. Close door on belt guard and latch.
9. Secure 45° discharge spout (M) Over the discharge opening using the head plate assembly and eight (8) 5/16" x 1-1/2" long bolts with nuts.
10. After everything has been adjusted, go back and tighten all nuts and bolts.

Tube Assembly (Continued)

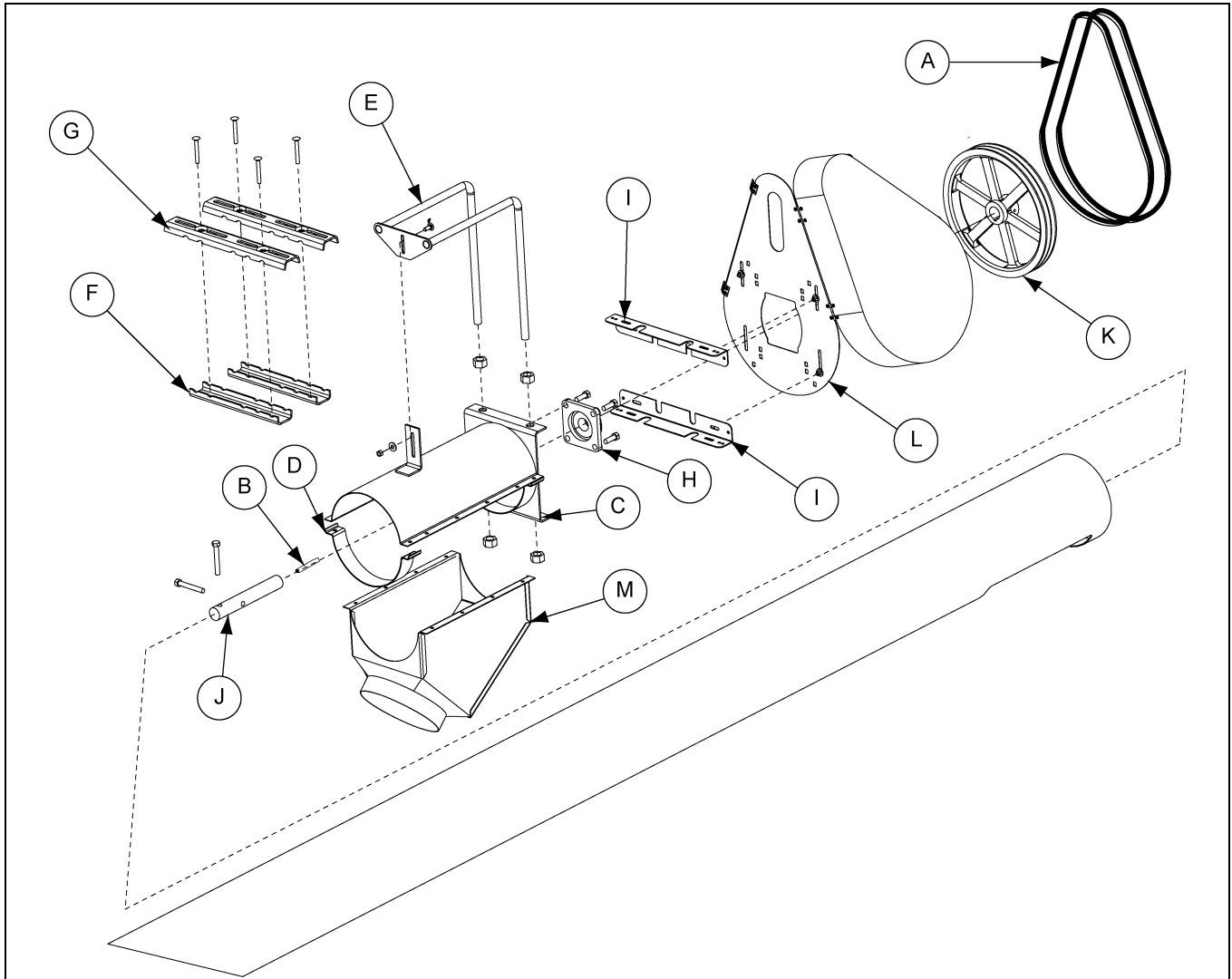

Figure 5A 10" Vertical Tube Assembly

Ref #	Description
A	Belt (57")
B	Key
C	Head Plate Assembly
D	Half Band Clamps
E	Motor Mount Rods
F	Motor Mount Top
G	Motor Mount Bottom

Ref #	Description
H	Flange Bearing
I	Top Mounting Angle
J	Head Drive Stub Shaft
K	Mount Pulley
L	Belt Guard
M	Discharge Spout



Lock out all power sources while installing or maintaining equipment.



Keep all safety devices and shields in place at all times until power source is locked out.

5. 10" Vertical Assembly Instructions

Attaching Vertical Section to Bin

1. Slide bin unloading flight into bin well and unloading tube (which should already be installed in bin). The unloading flight for larger bin sizes may need to be bolted together. Use bolts provided in connecting stubs located at the end of the tail flights. [See Chart below](#) to determine the flight length for the bin size.
2. Bolt unloading flight to short horizontal flight (Ref #C, [on Page 25](#)) using four (4) 1/2" x 3" long (grade 5) bolts and lock nuts.
3. Bolt flange on horizontal tube of vertical unloader to the flange of the bin unloader tube with vertical auger in vertical position. Use eight (8) 5/16" x 1" long bolts, lock washers and nuts.

10" Flight Chart

Product #	Bin Diameter	Part #	Description
GFC10240	24'	GK1826	14'-6" x 7" O.D. Flight
GFC10270	27'	GK1827	16'-0" x 7" O.D. Flight
GFC10300	30'	GK1828	17'-6" x 7" O.D. Flight
GFC10330	33'-34'	GK1829	19'-6" x 7" O.D. Flight
GFC10360	36'	GK1830	20'-6" x 7" O.D. Flight
GFC10380	37'-39'	GK1831	22'-6" x 7" O.D. Flight
GFC10400	40'	GK1832	23'-0" x 7" O.D. Flight
GFC10420	42'	GK1833	24'-0" x 7" O.D. Flight
GFC10480	48'-49'	GK1835 GK1834	20'-0" x 7" O.D. Flight (Head) 7'-0" x 7" O.D. Flight (Tail)
GFC10540	54'-55'	GK1835 GK1836	20'-0" x 7" O.D. Flight (Head) 10'-0" x 7" O.D. Flight (Tail)
GFC10600	60'	GK1835 GK1837	20'-0" x 7" O.D. Flight (Head) 13'-0" x 7" O.D. Flight (Tail)
GFC10630	63'	GK1835 GK1838	20'-0" x 7" O.D. Flight (Head) 14'-6" x 7" O.D. Flight (Tail)
GFC10680	68'-69'	GK1835 GK1839	20'-0" x 7" O.D. Flight (Head) 17'-0" x 7" O.D. Flight (Tail)
GFC10720	72'	GK1835 GK1840	20'-0" x 7" O.D. Flight (Head) 19'-0" x 7" O.D. Flight (Tail)
GFC10750	75'	GK1835 GK1841	20'-0" x 7" O.D. Flight (Head) 20'-6" x 7" O.D. Flight (Tail)
GFC10780	78'	GK1835 GK1842	20'-0" x 7" O.D. Flight (Head) 22'-6" x 7" O.D. Flight (Tail)
GFC10800	80'	GK1835 GK1844 GK1843	20'-0" x 7" O.D. Flight (Head) 20'-0" x 7" O.D. Flight (Middle) 4'-6" x 7" O.D. Flight (Tail)
GFC10820	82'	GK1835 GK1844 GK1845	20'-0" x 7" O.D. Flight (Head) 20'-0" x 7" O.D. Flight (Middle) 5'-6" x 7" O.D. Flight (Tail)
GFC10900	90'	GK1835 GK1844 GK1846	20'-0" x 7" O.D. Flight (Head) 20'-0" x 7" O.D. Flight (Middle) 9'-6" x 7" O.D. Flight (Tail)
GFC10920	92'	GK1835 GK1844 GK1847	20'-0" x 7" O.D. Flight (Head) 20'-0" x 7" O.D. Flight (Middle) 10'-6" x 7" O.D. Flight (Tail)

Attaching Vertical Section to Bin (Continued)

4. Adjust stand (Ref #X, [on Page 25](#)) so it holds the weight of the vertical auger.
5. Attach the support brackets and half bands to the top half of the vertical tube by inserting the 5/16" U-bolt (D) through the support brackets (E) and half bands (F) and fasten together using four (4) 5/16" nylon lock nuts.
6. Attach lower telescoping tube sections (C) to the ears on the support brackets (E) using two (2) 3/8" x 3/4" bolts with lock nuts.
7. Slide the upper telescoping tube sections (A) into the lower tube sections (C). Attach upper tubes to the bin wall.
8. Secure the upper telescoping tubes to the lower telescoping tubes by tightening the square head set screw (B).

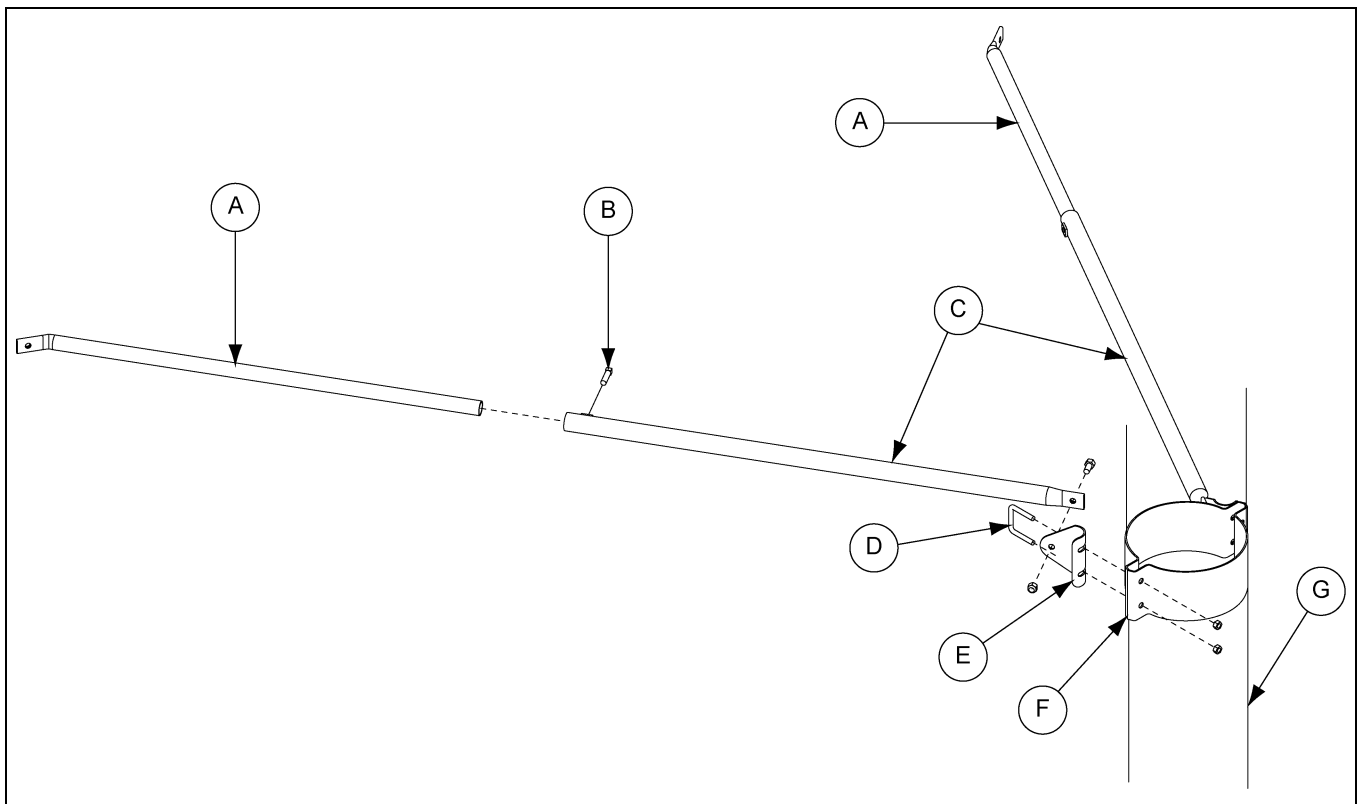

Figure 5B

Ref #	Description
A	Upper Telescoping Tube
B	Square Head Set Screw
C	Lower Tube
D	U-Bolt
E	Support Bracket
F	Half Band
G	Bin Wall

5. 10" Vertical Assembly Instructions

Attaching Horizontal Motor Mount (Direct Belt Drive)

1. First, connect the head stub shaft (U) to the short flight (C) using two (2) 1/2" x 3" (grade 5) bolts with lock nuts.
2. Connect the 4-hole flange bearing with lock collar (G) to the head plate (D) together using four (4) 1/2" x 1-1/2" bolts with lock nuts.
3. Attach the head plate (D) to the tube flange using eight (8) 5/16" x 1" bolts with flat washers, lock washers and nuts.
4. Connect side plates (I and J) to head plate (D) using four (4) 1/2" x 1-1/4" bolts with lock washers and nuts. **Also, at the same time, attach the belt guard brackets (Q) using the same bolts.**
5. Spin a 3/4" nut on the threaded rods of each strap and rod assembly (K). Insert threaded rods through holes in side plates (I and J) and add four (4) more 3/4" nuts. Leave only finger tight until later.
6. Place rods (L) in strap and rod assemblies (K) and secure with top straps (M) using 3/8" x 1-1/2" bolts with two (2) flat washers and one nut on each bolt.
7. Clamp belt guard mounting angle (Q) to rod ends (L) with clamp bar (R) using four (4) 5/16" x 1-3/4" bolts with nuts.
8. Attach belt guard back (O) to belt guard mounting angles (H) using four (4) 5/16" x 3/4" carriage bolts with flat washers and nuts.
9. Slide bearing lock collar (V) over head stub shaft (U). Leave enough stub exposed to mount pulley (N) on stub with drive key (W). Tighten bearing lock collar next to bearing and tighten set screws in pulley.
10. Position motor mount straps (F) and clips (E) and secure using four (4) 3/8" x 3" carriage bolts and nuts. Leave finger tight until later.
11. Install pulley on motor shaft and mount motor on strap (F). **(Motor and pulley not furnished.)** Install belts (A) and align pulleys. Tighten motor to straps (F). Adjust motors along the tube and tighten with 3/8" x 3" carriage bolts.
12. Set belt tension by adjusting height of motor using 3/4" nuts on rods.
13. Connect belt guard (P) by bolting belt guard clamp bar (T) to mounting angle (H) using 1/4" x 5-1/2" bolts with nuts. Attach second clamp bar (S) to belt guard mounting brackets (Q) using 1/4" x 5-1/2" bolts.

Attaching Horizontal Motor Mount (Direct Belt Drive) (Continued)

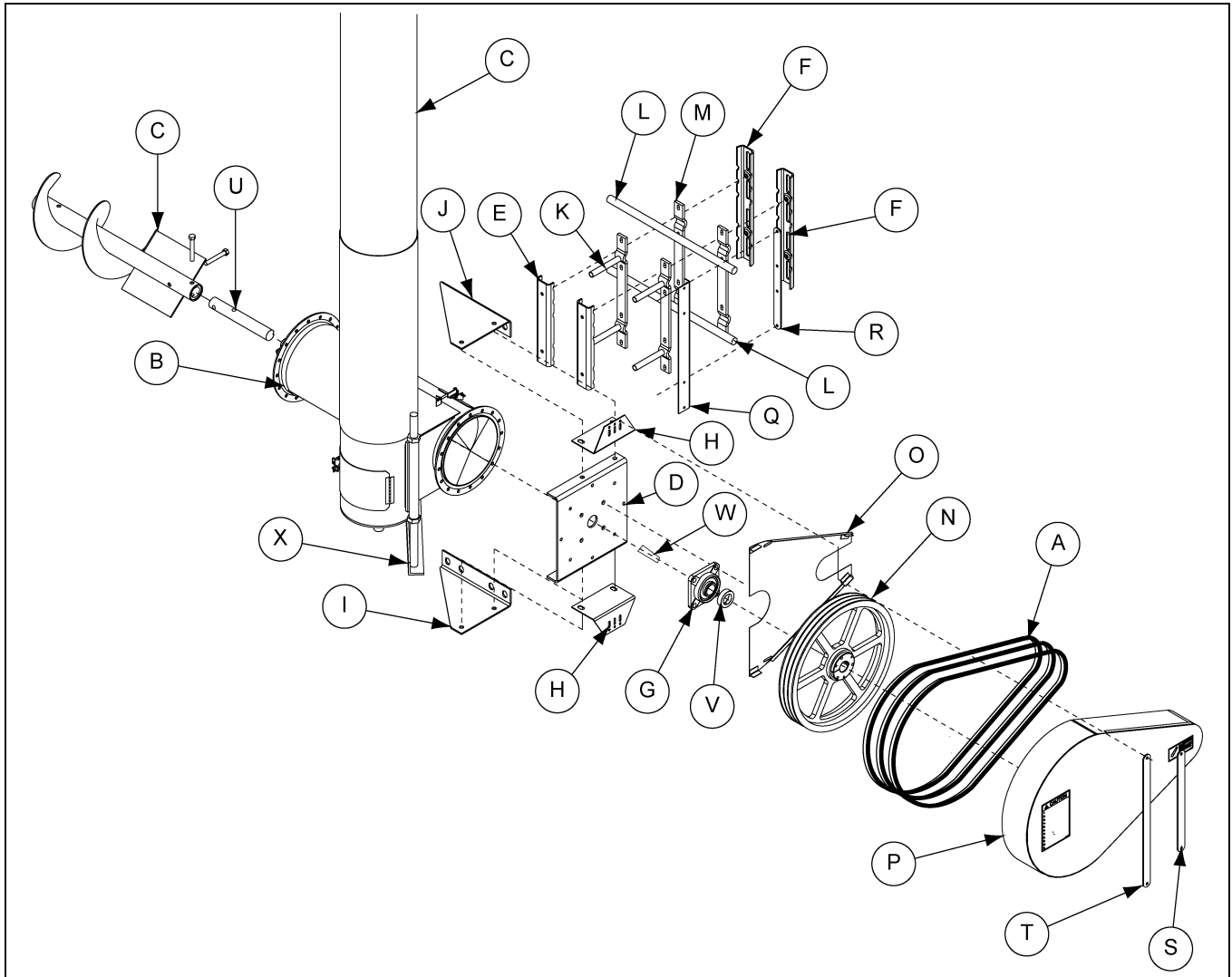

Figure 5C

Ref #	Description
A	Belt (71")
B	Vertical Cross Assembly
C	Short Flight
D	Head Plate
E	Clips
F	Motor Mount Straps
G	Lock Collar
H	Mounting Angle
I and J	Side Plates
K	Rod Assembly
L	Rod
M	Top Straps

Ref #	Description
N	Mount Pulley
O	Belt Guard Back
P	Belt Guard
Q	Belt Guard Mounting Angles
R	Clamp Bar
S	Second Clamp Bar
T	Belt Guard Clamp Bar
U	Head Stub Shaft
V	Bearing Lock Collar
W	Drive Key
X	Stand

6. Start-Up

Start-Up and Break-In



ALWAYS keep ALL guards and shields in place, until all the power is disconnected and locked out.

1. Make sure all belts are tensioned properly.
2. Make sure ALL shields are in place and that the belt(s) and pulley(s) are able to move freely.
3. Double check the assembly instructions to see that all parts have been assembled properly.
4. During operation of equipment, one person should be in a position to monitor the entire operation.



During the initial start-up and break-in period, the operator should note any unusual vibrations or noises and take the appropriate action.



Make certain everyone is clear before operating or moving the machine.

5. The bin well inside the bin should have a control gate. The gate should be closed before start-up and closed before shut down to allow the machine to clean out.
6. The controls for the control gate should either pull or push open, depending on the type of well you have. Use the control gate to regulate a flow of less than full capacity until several hundred bushels of grain have been augered to polish the flighting assembly and tube.
7. Any new screw conveyor or one that has set idle for a season should go through a “break-in” period. This “break-in” consists of running the auger at half capacity until the screw becomes polished and smooth before attempting to run at full capacity. It is recommended that several hundred bushels of grain be augered at partial capacity.

NOTE: *Failure of the auger is very likely to occur if it is run at full capacity before the screw has become polished.*

NOTE: *NEVER operate augers empty for any length of time as excessive wear will result.*

8. Do not stop or start augers under load, especially before the flight and tube become well polished, as this may cause the auger to “lockup”. Make sure to use the control gate as a flow control so the vertical auger cannot become plugged.

NOTE: *Excessive wear will result if auger is run at speeds in excess of what is recommended.*

8" Vertical Commercial Bin Unloading Auger Operating Instructions

- Parts Included:** 16'-6" vertical auger, horizontal tube 24" long with flange, horizontal drive with 2 or 3 belt drive, 2 belt vertical drive with pulleys, "B" belts, motor mount, mounting brackets, belt guard and 3' discharge spout. The horizontal unloading flight should be ordered separately.
- Capacity:** For cases with high moisture or high capacity requirements, use the next size larger motor. *(See Capacity Chart below.)*

Material	Capacity - 8"
Dry Grain	1000-1500
High Moisture	800-1200

- Vertical Drive:** Use a 4.6" motor pulley for recommended auger speed of 536 RPM.
- Horizontal Drive:** Use a 3-1/2" motor pulley for recommended auger speed of 408 RPM.
NOTE: Motor pulleys are NOT furnished with the auger.
- Vertical Horsepower:** Use a 5 HP Motor
- Horizontal Horsepower:** Use the horsepower [Chart below](#) to find the flight length to fit the needs.

8" Horizontal Flights for Vertical Height Unloaders

Product #	Bin Diameter	HP	Flight Length
GFC82400	24'	3	14'-6" x 7" O.D. Flight
GFC82700	27'	3	16'-0" x 7" O.D. Flight
GFC83000	30'	5	17'-6" x 7" O.D. Flight
GFC83300	33'-34'	5	19'-6" x 7" O.D. Flight
GFC83600	36'	5	20'-6" x 7" O.D. Flight
GFC83800	37'-39'	5	22'-6" x 7" O.D. Flight
GFC84000	40'	5	23'-0" x 7" O.D. Flight
GFC84200	42'	5	24'-0" x 7" O.D. Flight
GFC84800	48'-49'	5	27'-0" x 7" O.D. Flight
GFC85400	54'-55'	5	30'-0" x 7" O.D. Flight

Product #	Bin Diameter	HP	Flight Length
GFC86000	60'	5	33'-0" x 7" O.D. Flight
GFC86300	63'	5	34'-6" x 7" O.D. Flight
GFC86800	68'-69'	7-1/2"	37'-6" x 7" O.D. Flight
GFC87200	72'	7-1/2"	39'-0" x 7" O.D. Flight
GFC87500	75'	7-1/2"	40'-6" x 7" O.D. Flight
GFC87800	78'	10	42'-6" x 7" O.D. Flight
GFC88000	80'	10	44'-6" x 7" O.D. Flight
GFC88200	82'	10	45'-6" x 7" O.D. Flight
GFC89000	90'	10	49'-6" x 7" O.D. Flight
GFC89200	92'	10	50'-6" x 7" O.D. Flight

- The horsepower recommendations are for augering reasonably dry grain. High moisture grain (above 15%) will require greater power if maximum capacity is to be maintained. The maximum possible capacity will be less with high moisture grain than with dry grain. Use an electric motor of the correct size that operates at 1750 RPM.



Electrical controls and wiring should be installed by a qualified electrician. The motor disconnect switches and conductor cables should comply with the National Electrical Code and any local codes which apply. Motor starting control stations should be so located that the operator can see that all personnel are clear of the equipment.

10" Vertical Commercial Bin Unloading Auger Operating Instructions

- Parts Included:** 16'-6" vertical auger, horizontal tube 30" long with flange, horizontal drive with 2 or 3 belt drive, 2 belt vertical drive with pulleys, "B" belts, motor mount, mounting brackets, belt guard and 3' discharge spout. The horizontal unloading flight should be ordered separately.
- Capacity:** For cases with high moisture or high capacity requirements, use the next size larger motor. *(See Capacity Chart below.)*

Material	Capacity - 10"
Dry Grain	1600-2000
High Moisture	1300-1600

- Vertical Drive:** Use a 4.6" motor pulley for recommended auger speed of 408 RPM.
- Horizontal Drive:** Use a 3.4" motor pulley for recommended auger speed of 323 RPM.

NOTE: Motor pulleys are NOT furnished with the auger.

- Vertical Horsepower:** Use a 7-1/2 HP Motor
- Horizontal Horsepower:** Use the horsepower *Chart below* to find the flight length to fit the needs.

10" Horizontal Flights for Vertical Height Unloaders

Product #	Bin Diameter	HP	Flight Length
GFC10240	24'	5	14'-6" x 7" O.D. Flight
GFC10270	27'	5	16'-0" x 7" O.D. Flight
GFC10300	30'	5	17'-6" x 7" O.D. Flight
GFC10330	33'-34'	5	19'-6" x 7" O.D. Flight
GFC10360	36'	7-1/2"	20'-6" x 7" O.D. Flight
GFC10380	37'-39'	7-1/2"	22'-6" x 7" O.D. Flight
GFC10400	40'	7-1/2"	23'-0" x 7" O.D. Flight
GFC10420	42'	7-1/2"	24'-0" x 7" O.D. Flight
GFC10480	48'-49'	7-1/2"	27'-0" x 7" O.D. Flight
GFC10540	54'-55'	7-1/2"	30'-0" x 7" O.D. Flight

Product #	Bin Diameter	HP	Flight Length
GFC10600	60'	10	33'-0" x 7" O.D. Flight
GFC10630	63'	10	34'-6" x 7" O.D. Flight
GFC10680	68'-69'	10	37'-6" x 7" O.D. Flight
GFC10720	72'	10	39'-0" x 7" O.D. Flight
GFC10750	75'	10	40'-6" x 7" O.D. Flight
GFC10780	78'	10	42'-6" x 7" O.D. Flight
GFC10800	80'	15	44'-6" x 7" O.D. Flight
GFC10820	82'	15	45'-6" x 7" O.D. Flight
GFC10900	90'	15	49'-6" x 7" O.D. Flight
GFC10920	92'	15	50'-6" x 7" O.D. Flight

- The horsepower recommendations are for augering reasonably dry grain. High moisture grain (above 15%) will require greater power if maximum capacity is to be maintained. The maximum possible capacity will be less with high moisture grain than with dry grain. Use an electric motor of the correct size that operates at 1750 RPM.



Electrical controls and wiring should be installed by a qualified electrician. The motor disconnect switches and conductor cables should comply with the National Electrical Code and any local codes which apply. Motor starting control stations should be so located that the operator can see that all personnel are clear of the equipment.

Power Source

1. Use electric motors that operate at 1750 RPM.
2. Electric motors and controls should be installed by a qualified electrician and must meet the standards set by the National Electrical Code and all local and state codes.
3. A magnetic starter should be used to protect the motor when starting and stopping. It should stop the motor in case of power interruption, conductor fault, low voltage, circuit interruption or motor overload. Then the motor must be restarted manually. Some motors have built-in thermal overload protection. If this type motor is used, use only those with a manual reset.



You should use a Main Power Disconnect switch capable of being locked only in the OFF position. This should be locked whenever work is being done on the auger.

NOTE: *Disconnect power before resetting motor overloads.*



Make sure all electrical motors are grounded.



Reset and motor starting and stopping controls must be located so that the operator has full view of the entire operation.



Shut off power to adjust, service or clean the machinery.



Keep all safety guards and shields in place.

Maintenance

1. The flange bearings on the head and tail ends of all units should be lubricated on frequent intervals.



Never clean, adjust or lubricate a machine that is in operation.

8. Shut Down

Normal Shut Down

1. Make certain that bin well and unloading tubes are empty before stopping the unit.
2. Disconnect and lock out the power source before leaving the work area.

Emergency Shut Down

1. Know how to shut down the auger in case of an emergency.
2. Disconnect and lock out the power source.
3. Close bin well control gates.
4. Clear out as much grain from the auger and hopper as you can.

NOTE: *Never restart when under a full load. Starting unit under load may result in damage to the machine. Such damage is considered abuse of the equipment.*

5. Reconnect and unlock the power source.
6. Gradually clear the auger until there is no grain or obstructions.

Lock Out

1. Always stop and disconnect the power source whenever the operator must leave the work area or for maintenance of the machinery.
2. Make sure no one can operate the unload auger while the operator is not in the work area.

NOTE: *Use the type of main power disconnect switch that is capable of being locked only in the off position.*

Storage Preparation

1. Close all wells to discharge tube.
2. Be sure the unload tube is empty.
3. Make sure power source is disconnected and locked out.
4. Check to see that all fasteners are secure.

Troubleshooting Guide

Problem	Possible Cause	Solution
The auger is vibrating.	1. Damage can occur to the auger flighting, causing noise. Damage usually is caused from foreign material being run through the auger.	1. It may be necessary to remove the flighting for inspection.
	2. Drive belt may be overtightened, putting head stub and flight in a bind.	2. Loosen the drive belts.
Capacity is too low.	1. There may not be enough grain reaching the auger.	1. Make sure the intake has not bridged over, restricting flow. The flighting at the intake should be covered with grain for maximum capacity.
	2. The auger is moving too slowly.	2. Check the auger speed. Low capacity will result from speeds slower than recommended.
The auger plugs.	1. The auger may be “jamming” because too much grain is reaching the auger.	1. Use the control gates to decrease the amount of grain the auger is gathering.
	2. The grain may be wet.	2. If wet grain or other hard-to-move material is being augered, use a larger size motor than recommended for normal use.
	3. The auger may be jammed with foreign material.	3. Remove any foreign material in the auger.
	4. The motor may be too small or wired incorrectly.	4. Check wiring or consider using the next larger size motor.

NOTES

1. 8" Commercial Vertical Bin Unload Auger Parts *(See Pages 34 and 35.)*
2. 10" Commercial Vertical Bin Unload Auger Parts *(See Pages 36 and 37.)*

8" Commercial Vertical Bin Unload Auger Parts

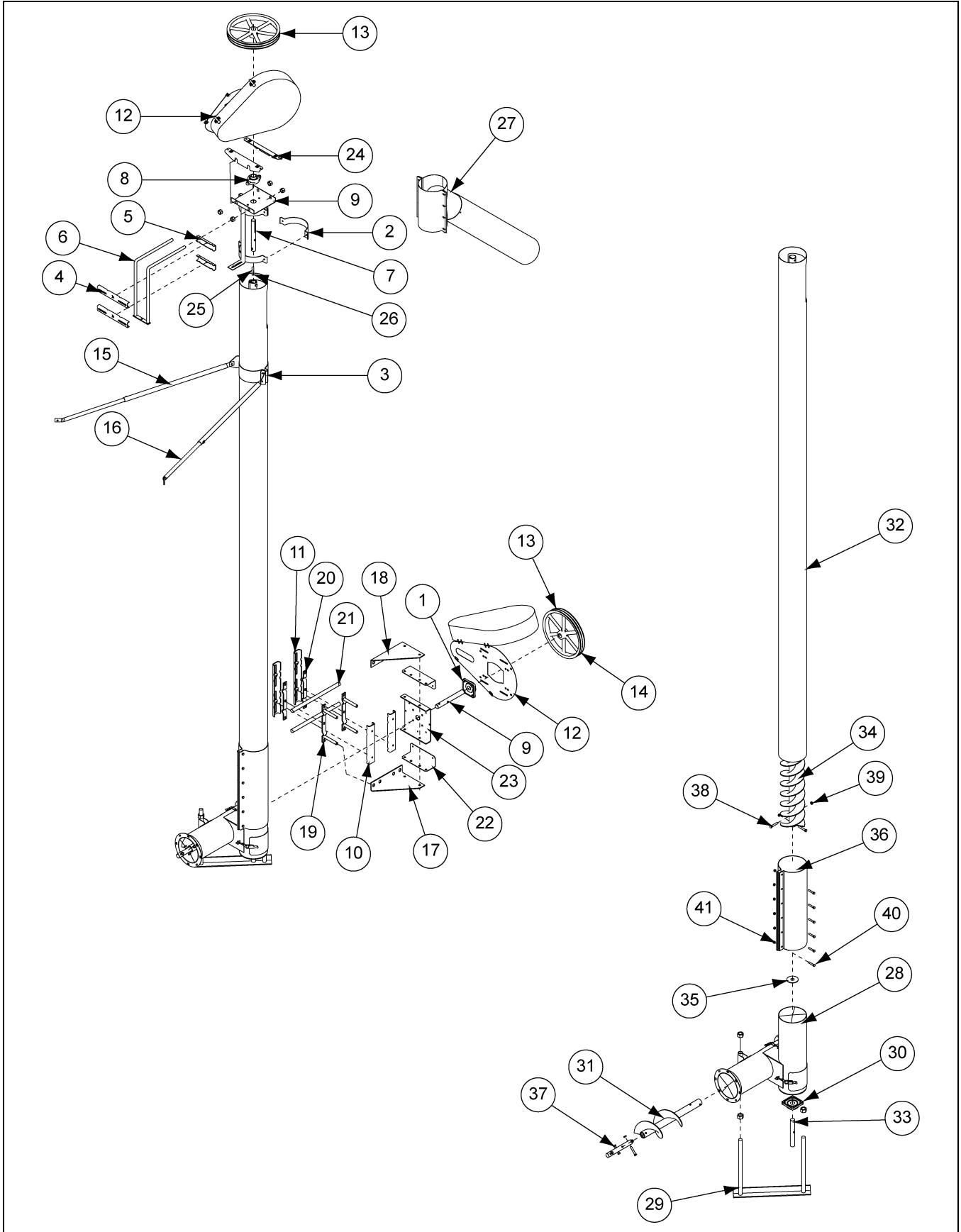

8" Commercial Vertical Bin Unload Auger Parts List

Ref #	Part #	Description
1	GK1017	1-1/4" Bore Flange Bearing with Lock
2	GK1055	8" x 2" Wide Galvanized Half Band
3	GK1059	8" x 4" Wide Galvanized Half Band - 12 Gauge
4	GK1063	Motor Mount Top Strap
5	GK1064	Motor Mount Bottom Strap
6	GK1327	8" Motor Mount Weldment
7	GK1331	Drive Shaft - 1-1/4" O.D. x 10-1/2"
8	GK1330	1-1/4" 2 Hole Flange Bearing
9	GK1329	8" Head Plate Assembly
10	GK1341	Motor Mount Bottom
11	GK1342	Motor Mount Top
12	GK1454	Belt Guard Assembly
13	GK1869	Aluminum Sheave - 15" x 1-1/4" for two (2) Belts
14	GK2234	Aluminum Sheave - 15" x 1-1/4" for three (3) Belts
15	GK1891	Inner Leg Telescoping Tube 32"
16	GK1892	Outer Leg Telescoping Tube 36"
17	GK1897	Left Side Motor Mount
18	GK1898	Right Side Motor Mount
19	GK2108	8" Strap and Rod Assembly
20	GK2109	8" Top Strap
21	GK2110	Motor Mount 1" O.D. x 19" Long
22	GK3096	Belt Guard Mounting Angle Power Head Vertical
23	GK3097	8" Head Plate for Power Head Vertical
24	GK1344	Belt Guard Mounting Angle
25	S-8276	3" Key - 1/4" x 1/4" x 3"
26	S-4513	2" Key - 1/4" x 1/4" x 2"
27	GK1002	Spout 45° 8" x 3' 8" Tube
28	GK3090	Vertical Cross Assembly
29	GK3088	Support Stand Assembly
31	GK3087	Head Flight 7" O.D. x 23" Long
32	GK3086	8" O.D. x 14'-5" Unloading Tube
33	GK1884	Shaft, Intake 1-1/4" Diameter x 9"
34	GK1004-2	Vertical Flight Weldment
35	GK1113	Rubber Washer
36	GK1015	Connecting Band
37	GK1328	Connecting Shaft
38	S-7013	Bolt, HHCS 7/16"-14 x 2-1/2" ZN Grade 5
39	S-7170	Lock Nut 7/16"-14 ZN Grade 2
40	S-7522	Bolt, HHCS 3/8"-16 x 2" ZN Grade 2
41	S-456	Hex Nut 3/8"-16 YDP Grade 5
N/S	GK1317	Decals Package Bin Safety
N/S	GK1346	V-Belt B-57
N/S	GK3098	8" Bolt Kit
N/S	GK4235	Hardware Mounting Bracket Vertical Double Drive
N/S	MHC-00487	V-Belt B-71
N/S	PNEG-1057	8" and 10" Commercial Vertical Bin Unload Auger
N/S	PNEG-777	Shortage Claim Sheet

10" Commercial Vertical Bin Unload Auger Parts

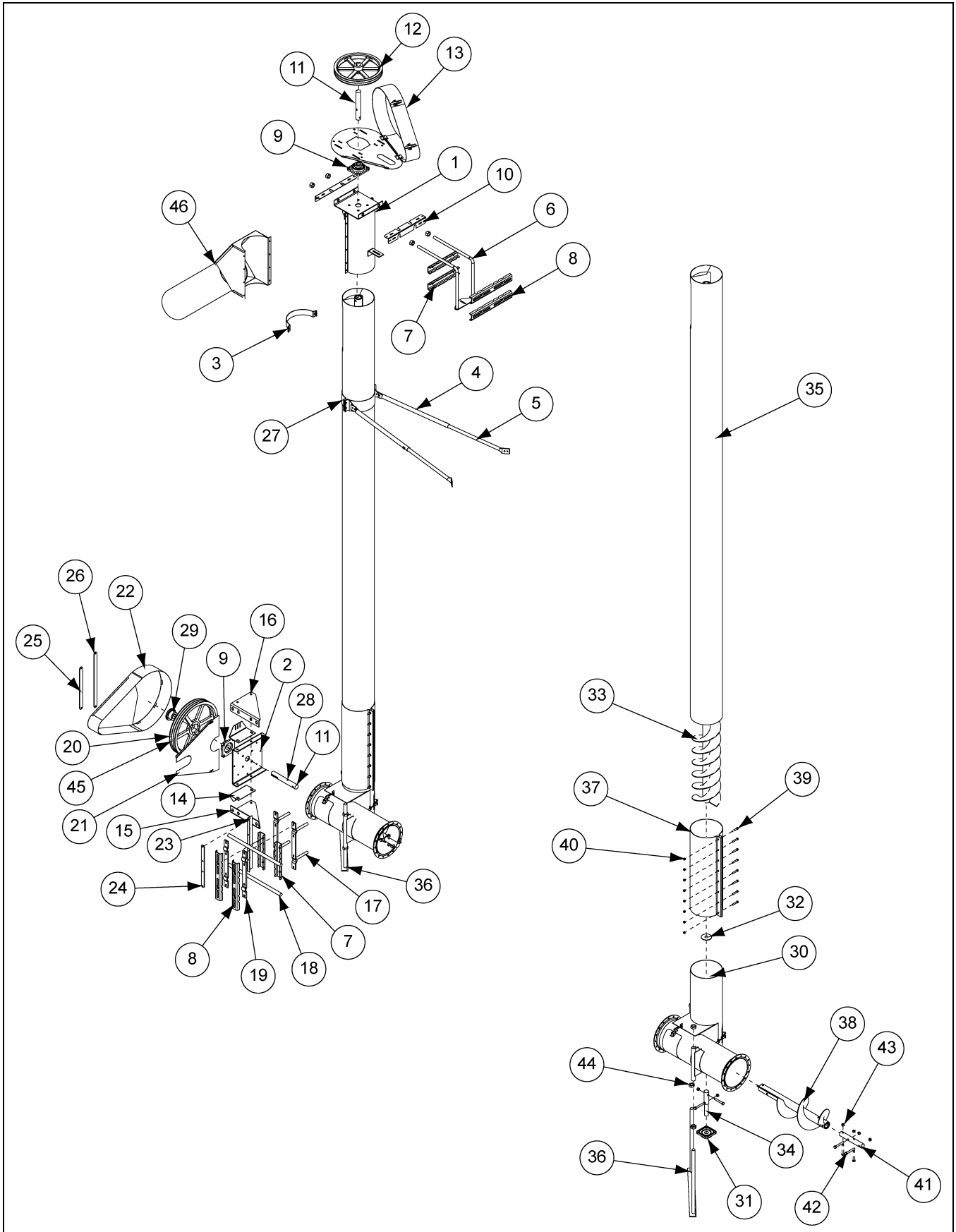

10" Commercial Vertical Bin Unload Auger Parts List

Ref #	Part #	Description
1	GK1349	10" Head Plate Assembly
2	GK2561	Head Plate for Direct Belt Drive
3	GK1057	10" x 2" Wide Galvanized Half Band
4	GK1028	Telescoping Tube Less Set Screw
5	GK1033	28" Telescoping Tube
6	GK1350	10" Motor Mount Weldment
7	GK1341	Motor Mount Bottom
8	GK1342	Motor Mount Top
9	GK1343	1-1/2" Bearing Flange
10	GK1344	Belt Guard Mounting Angle
11	GK1340	Stub Drive 1-1/2" O.D. x 10-1/2"
12	GK1345	Aluminum Sheave - 15" x 1-1/2" for two (2) Belts
13	GK1454	Belt Guard Assembly
14	GK2569	Belt Guard Support
15	GK1897	Left Side Motor Mount
16	GK1898	Right Side Motor Mount
17	GK1900	10" Strap and Rod Assembly
18	GK1893	Motor Mount Rod
19	GK1901	Top Strap
20	GK2567	Sheave: 18.4" O.D. without Bushing Z-Belt
21	GK2568	Belt Guard Back Weldment
22	GK2565	Belt Guard Front Weldment
23	GK2017	Belt Guard Mounting Angle
24	GK2018	Clamp Bar for Mounting Angle
25	GK2019	Clamp Bar for Belt Guard (16")
26	GK2564	Clamp Bar for Belt Guard
27	GK1301	10" x 4" Wide Galvanized Half Band
28	GK2562	1-1/2" O.D. x 9-1/2" Long Drive Stub
29	GK4248	1-1/2" SK Bushing
30	GK1882	Vertical Cross Assembly
31	GK1017	1-1/4" Bore Flange Bearing with Lock
32	GK1113	Rubber Washer
33	GK1876	9" O.D. x 16-1/2" Long Vertical Unloading Flight
34	GK4886	1-1/4" to 1-1/2" x 9" Tail Stub
35	GK1877	10" x 14' Unloading Tube
36	GK1879	Support Stand Assembly
37	1883	Connecting Band
38	2563	29" Head Flight 9" O.D. (Direct Belt Drive)
39	S-7522	Bolt, HHCS 3/8"-16 x 2" ZN Grade 2
40	S-456	Hex Nut 3/8"-16 YDP Grade 5
41	GK1137	1-1/2" x 9-1/2" Stub Shaft
42	S-8314	Bolt, HHCS 1/2"-13 x 3-1/2" YDP Grade 8
43	S-8315	Lock Nut 1/2"-13 ZN GRC Prevailing Torque
44	S-240	Hex Nut 1-8 - Zinc Grade 5
45	GK2570	Sheave: 18.4" O.D. w/out Bushing 3-Belt
46	GK1875	Spout
N/S	S-7079	U-Bolt, 5/16"-18 x 1-3/4" IW x 1-3/4" IL
N/S	S-7116	Bolt, HHCS 1/4"-20 x 5-1/2" ZN Grade 2
N/S	GK4235	Hardware, Mounting Bracket Vertical Double Drive
N/S	GK4247	Mounting Bracket Hardware for 10"
N/S	GK1317	Decals Package Bin Safety
N/S	PNEG-1057	8" and 10" Commercial Vertical Bin Unload Auger
N/S	PNEG-777	Shortage Claim Sheet
N/S	GK1346	V-Belt B-57
N/S	MHC-00487	V-Belt B-71
N/S	S-1054	Split Lock Washer 3/8" ZN

NOTES

GSI Group, LLC Limited Warranty

The GSI Group, LLC ("GSI") warrants products which it manufactures to be free of defects in materials and workmanship under normal usage and conditions for a period of 12 months after sale to the original end-user or if a foreign sale, 14 months from arrival at port of discharge, whichever is earlier. The end-user's sole remedy (and GSI's only obligation) is to repair or replace, at GSI's option and expense, products that in GSI's judgment, contain a material defect in materials or workmanship. Expenses incurred by or on behalf of the end-user without prior written authorization from the GSI Warranty Group shall be the sole responsibility of the end-user.

Warranty Extensions:

The Limited Warranty period is extended for the following products:

	Product	Warranty Period	
AP Fans and Flooring	Performer Series Direct Drive Fan Motor	3 Years	* Warranty prorated from list price: 0 to 3 years - no cost to end-user 3 to 5 years - end-user pays 25% 5 to 7 years - end-user pays 50% 7 to 10 years - end-user pays 75%
	All Fiberglass Housings	Lifetime	
	All Fiberglass Propellers	Lifetime	
AP and Cumberland	Flex-Flo/Pan Feeding System Motors	2 Years	
Cumberland Feeding/Watering Systems	Feeder System Pan Assemblies	5 Years **	** Warranty prorated from list price: 0 to 3 years - no cost to end-user 3 to 5 years - end-user pays 50%
	Feed Tubes (1-3/4" and 2.00")	10 Years *	
	Centerless Augers	10 Years *	
	Watering Nipples	10 Years *	
Grain Systems	Grain Bin Structural Design	5 Years	
Grain Systems Farm Fans Zimmerman	Portable and Tower Dryers	2 Years	† Motors, burner components and moving parts not included. Portable dryer screens included. Tower dryer screens not included.
	Portable and Tower Dryer Frames and Internal Infrastructure †	5 Years	

GSI further warrants that the portable and tower dryer frame and basket, excluding all auger and auger drive components, shall be free from defects in materials for a period of time beginning on the twelfth (12th) month from the date of purchase and continuing until the sixtieth (60th) month from the date of purchase (extended warranty period). During the extended warranty period, GSI will replace the frame or basket components that prove to be defective under normal conditions of use without charge, excluding the labor, transportation, and/or shipping costs incurred in the performance of this extended warranty.

Conditions and Limitations:

THERE ARE NO WARRANTIES THAT EXTEND BEYOND THE LIMITED WARRANTY DESCRIPTION SET FORTH ABOVE. SPECIFICALLY, GSI MAKES NO FURTHER WARRANTY OF ANY KIND, EXPRESS OR IMPLIED, INCLUDING, WITHOUT LIMITATION, WARRANTIES OF MERCHANTABILITY OR FITNESS FOR A PARTICULAR PURPOSE OR USE IN CONNECTION WITH: (I) PRODUCT MANUFACTURED OR SOLD BY GSI OR (II) ANY ADVICE, INSTRUCTION, RECOMMENDATION OR SUGGESTION PROVIDED BY AN AGENT, REPRESENTATIVE OR EMPLOYEE OF GSI REGARDING OR RELATED TO THE CONFIGURATION, INSTALLATION, LAYOUT, SUITABILITY FOR A PARTICULAR PURPOSE, OR DESIGN OF SUCH PRODUCTS.

GSI shall not be liable for any direct, indirect, incidental or consequential damages, including, without limitation, loss of anticipated profits or benefits. The sole and exclusive remedy is set forth in the Limited Warranty, which shall not exceed the amount paid for the product purchased. This warranty is not transferable and applies only to the original end-user. GSI shall have no obligation or responsibility for any representations or warranties made by or on behalf of any dealer, agent or distributor.

GSI assumes no responsibility for claims resulting from construction defects or unauthorized modifications to products which it manufactured. Modifications to products not specifically delineated in the manual accompanying the equipment at initial sale will void the Limited Warranty.

This Limited Warranty shall not extend to products or parts which have been damaged by negligent use, misuse, alteration, accident or which have been improperly/inadequately maintained. This Limited Warranty extends solely to products manufactured by GSI.

Prior to installation, the end-user has the responsibility to comply with federal, state and local codes which apply to the location and installation of products manufactured or sold by GSI.

This equipment shall be installed in accordance with the current installation codes and applicable regulations, which should be carefully followed in all cases. Authorities having jurisdiction should be consulted before installations are made.



**1004 E. Illinois St.
Assumption, IL 62510-0020
Phone: 1-217-226-4421
Fax: 1-217-226-4420
www.gsiag.com**



GSI is a worldwide brand of AGCO Corporation.