

PNEG-1071
05-21-02
Revision No. 1

6", 8", 10", & 12" Custom Augers

6", 8", 10", & 12" Custom Augers

Assembly & Operation Manual

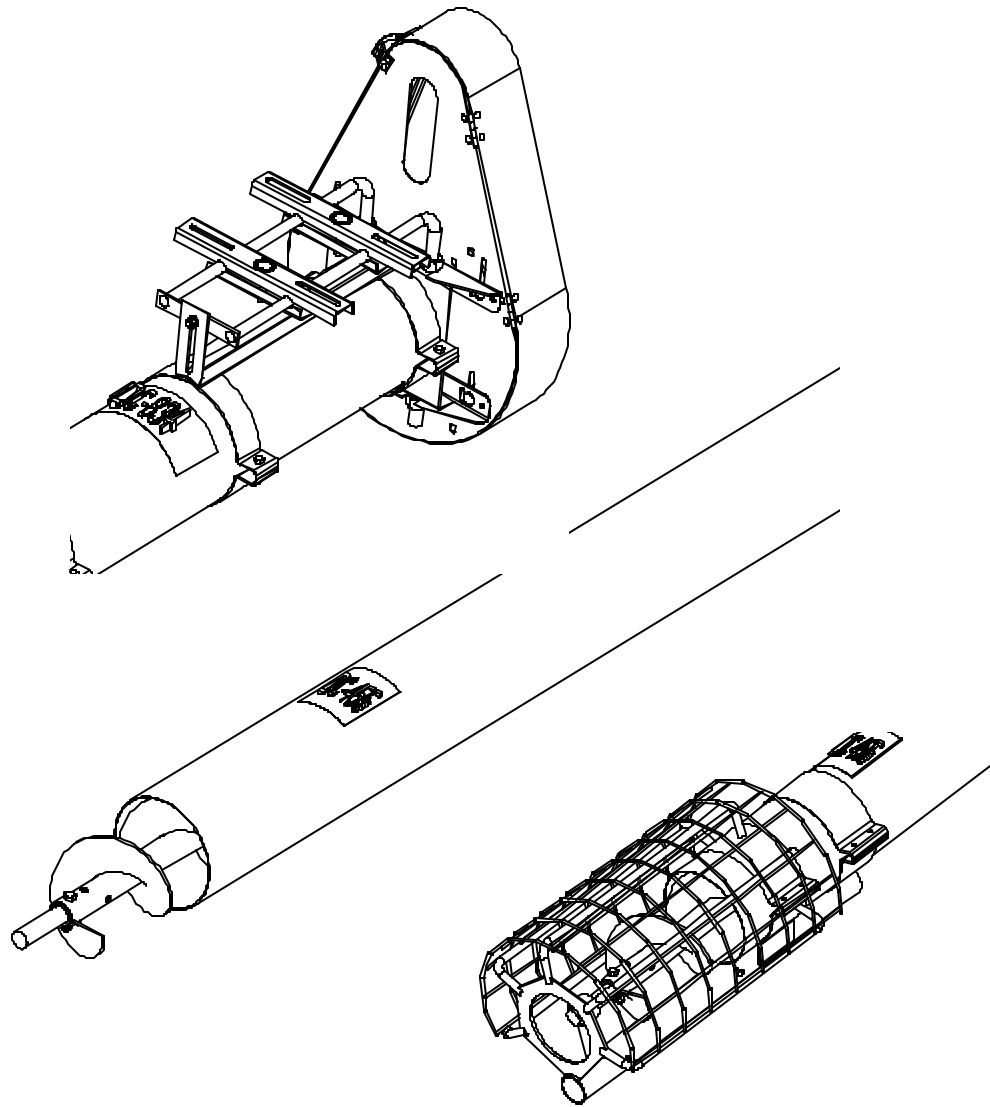

PNEG-1071
05-21-02
Revision No. 1

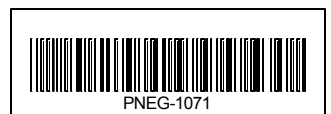

SAFETY GUIDELINES

This manual contains information that is important for you, the owner/operator, to know and understand. This information relates to protecting **personal safety** and **preventing equipment problems**. It is the responsibility of the owner/operator to inform anyone operating or working in the area of this equipment of these safety guidelines. To help you recognize this information, we use the symbols that are defined below.

Please read the manual and pay attention to these sections. Failure to read this manual and its safety instructions is a misuse of the equipment and may lead to serious injury or death.



This is the safety alert symbol. It is used to alert you to potential personal injury hazards. Obey all safety messages that follow this symbol to avoid possible injury or death.



DANGER indicates an imminently hazardous situation which, if not avoided, will result in death or serious injury.



WARNING indicates a potentially hazardous situation which, if not avoided, could result in death or serious injury.



CAUTION indicates a potentially hazardous situation which, if not avoided, may result in minor or moderate injury.



CAUTION used without the safety alert symbol indicates a potentially hazardous situation which, if not avoided, may result in property damage.



NOTE indicates information about the equipment that you should pay special attention to.

SAFETY GUIDELINES

1. General Safety Guidelines

- A. **DO NOT** make any alterations to the equipment. Such alterations may produce a very dangerous situation, where **SERIOUS INJURY** or **DEATH** may occur.
- B. This equipment shall be installed in accordance with any regulations or installation codes that are required by law. Authorities having jurisdiction should be consulted before installations are made.
- C. Untrained operators subject themselves and others to **SERIOUS INJURY** or **DEATH**. **NEVER** allow untrained personnel to operate this equipment.
- D. Keep children and other unqualified personnel out of the working area at **ALL** times.
- E. **NEVER** start equipment until **ALL** persons are clear of the work area.
- F. Be sure **ALL** operators are adequately rested and prepared to perform **ALL** functions of operating this equipment.
- G. Keep hair, loose clothing, and shoestrings away from rotating and moving parts. **NEVER** wear loose fitting clothing when working around augers.
- H. **NEVER** allow any person intoxicated or under the influence of alcohol or drugs to operate the equipment.
- I. **NEVER** allow anyone inside a bin, truck, or wagon which is being unloaded by an auger or conveyor. Flowing grain can trap and suffocate in seconds.
- J. Make sure someone is nearby who is aware of the proper shutdown sequence in the event of an accident or emergency.
- K. **NEVER** work alone.
- L. **ALWAYS** think before acting. **NEVER** act impulsively around the equipment.
- M. Make sure **ALL** equipment is locked in position before operating.
- N. Keep hands and feet away from the auger intake and other moving parts.
- O. **NEVER** attempt to assist machinery operation or to remove trash from equipment while in operation.
- P. **NEVER** drive, stand, or walk under the equipment.
- Q. Use caution not to hit the auger when positioning the load.
- R. Use ample overhead lighting after sunset to light the work area.
- S. **ALWAYS** lockout **ALL** power to the equipment when finished unloading.
- T. Keep area around intake free of obstacles such as electrical cords, blocks, etc. that might trip workers.

SAFETY GUIDELINES

2. Personal Protective Equipment

A. The proper personal protective equipment should be worn at **ALL** times by anyone in the work area.

**2-B**

B. **ALWAYS** wear safety glasses when in the work area.

**2-C**

C. The operator should **NEVER** wear jewelry.

**2-D, E**

D. Loose clothing should not be worn. Any clothing that becomes loosened should be tucked in tightly.

E. Loose or dangling shoe strings should be tucked in.

**2-F**

F. Long hair should be tied up and/or back.

SAFETY GUIDELINES

3. Emergency Shutdown Sequence

- A. In an emergency, shutdown the power source.

4. Pinch Points



NOTE: A *Pinch Point* is any place on the equipment which can injure the operator.

- A. Components of this equipment have sharp edges which can scrape and/or cut an operator.
- B. A moving auger can sever an operator's limbs or even kill him/her.

5. Shields and Guards

- A. **ALWAYS** keep **ALL** shields and guards in place during operation.

We will replace any missing shields or guards free of charge!

See (page VI) for more information on our Safety First program.

Safety **1st**

6. Operator Qualifications

- A. The User/Operator must be competent and experienced to operate auger equipment. Anyone who works with or around augers must have good common sense in order to be qualified. These persons must also know and meet all other qualifications, such as:
 - 1. Any person who has not read and/or does not understand all operation and safety procedures is not qualified to operate any auger systems.
 - 2. Certain regulations apply to personnel operating power machinery. Personnel under the age of 18 years may not operate power machinery, including augers. It is your responsibility, as owner and/or supervisor, to know what these regulations are in your area or situation.
 - 3. Unqualified or incompetent persons are to remain out of the work area.
 - 4. O.S.H.A. (Occupational Safety & Health Administration) regulations state:
"At the time of initial assignment and at least annually thereafter, the employer shall instruct every employee in the safe operation and servicing of all equipment with which the employee is, or will be involved." (Federal Occupational Safety & Health Standards for Agriculture. Subpart D, Section 19287.57 (a) (6).

SAFETY GUIDELINES

6. Operator Qualifications *(cont.)*

B. As a requirement of OSHA, it is necessary for the employer to train the employee in the safe operating and safety procedures for this auger. We included this sign-off sheet for your convenience and personal record keeping. All unqualified persons are to stay out of the work area at all times. It is strongly recommended that another qualified person who knows the shutdown procedure is in the area in the event of an emergency. A person who has not read this manual and understands all operating and safety instructions is not qualified to operate the machine.

Date	Employer's Signature	Employee Signature
1		
2		
3		
4		
5		
6		
7		
8		
9		
10		
11		
12		
13		
14		
15		
16		
17		
18		
19		
20		
21		
22		

SAFETY GUIDELINES



Our equipment is built to provide many years of dependable service to our customers through durable craftsmanship.

One of the most important aspects of our engineering is **SAFETY 1st** design throughout all product lines. At our company - safety is NO ACCIDENT!

That is why we have implemented a **SAFETY 1st** program. Should you ever need guards, shields, safety decals or owner/operator manuals, simply contact us or your local dealer, and we will supply you with them **FREE OF CHARGE!**

While it is our main goal for our company to be the world leader in auger manufacturing, it is always our first priority to keep our customers safe.

If you need any of the above listed safety items or have any safety questions, please contact the manufacturer or your local dealer.

*We replace missing guards and shields
FREE OF CHARGE!*

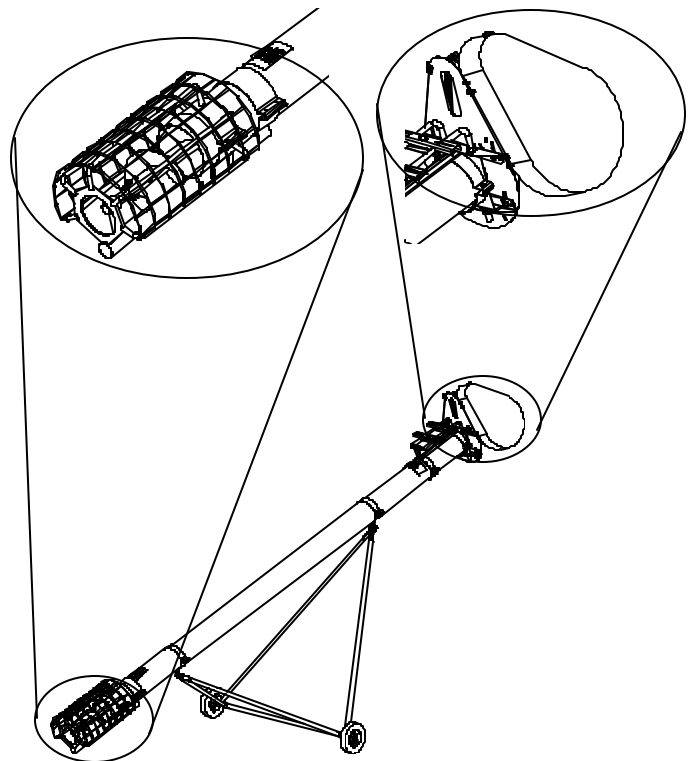

DISCLAIMER

OUR COMPANY ASSUMES NO LIABILITY AND MAKES NO REPRESENTATIONS OR WARRANTIES, EXPRESS OR IMPLIED, FOR ANY OF ITS COMPONENT PARTS USED IN ANY APPLICATION OTHER THAN AS EXACT REPLACEMENT FOR OUR PARTS IN ONE OF OUR SYSTEMS APPLICATION APPROVED IN WRITING BY US. IN THE EVENT OF ANY OTHER USE OR APPLICATION, THE PURCHASER AND/OR END USER IS WHOLLY RESPONSIBLE FOR THE FITNESS, COMPATIBILITY, STRUCTURAL ADEQUACY, AND FUNCTIONALITY OF THE COMPONENT PART AND ANY ADJOINING AND ADJACENT EQUIPMENT OR STRUCTURES.

PERSONNEL OPERATING OR WORKING AROUND THIS EQUIPMENT SHOULD READ THIS MANUAL. THIS MANUAL MUST BE DELIVERED WITH EQUIPMENT TO ITS OWNER. FAILURE TO READ THIS MANUAL AND ITS SAFETY INSTRUCTIONS IS A MISUSE OF THE EQUIPMENT. ANY MISUSE OF THE EQUIPMENT MAY VOID THE WARRANTY.

Safety Guidelines i

SAFETY 1st vi

Table of Contents vii

Decals 1

Introduction 5

Assembly

 6" Standard Duty Drive Mount 6

 8" Standard Duty Drive Mount 8

 8" Standard Heavy Drive Mount 10

 10" Standard Duty Drive Mount 12

 10" Standard Heavy Drive Mount 14

 12" Standard Heavy Drive Mount 16

Outlet Cutting Guidelines 18

Slide Gate with Rack and Pinion 19

Hoppers 20

Intake Guard and Control Gate 21

Flighting and Tubing 22

Spouting & Truss Kits 23

Operation & Maintenance 24

Startup 25

Shutdown 26

Troubleshooting 27

Parts List 28

Warranty

NOTES

SAFETY DECALS

The Decal List below has all the safety decals that should be included with your equipment. The following pages show what the decals look like and where they should be located on the equipment. Inspect all decals and replace any that are illegible, worn, or missing. Contact your local dealer or the manufacturer to order replacement decals free of charge.

Decal List			
Ref. #	Part #	Description	Size
1	DC-995	Warning - Shear Point	4-1/2" x 2"
2	DC-994	Danger - Shear Point	4-1/2" x 2"
3	DC-834	Danger - Unloading	9" x 3-3/4"
4	DC-1379	Notice - 1 -11	5-1/8" x 7-3/8"
5	DC-1395	Danger - Rotating Flight	4-1/4" x 6-1/4"
6	DC-455	Danger - Rotating Flight	4" x 5-3/4"

①
DC-995



②
DC-994



③
DC-834



SAFETY DECALS

④

DC-1379

NOTICE

1. READ AND UNDERSTAND THE OPERATOR'S MANUAL AND ALL SAFETY INSTRUCTIONS.
2. DO NOT OPERATE WHILE UNDER THE INFLUENCE OF DRUGS OR ALCOHOL.
3. DO NOT OPERATE UNLESS ALL SAFETY EQUIPMENT, SWITCHES, GUARDS AND SHIELDS ARE SECURELY IN PLACE AND OPERATIONAL.
4. ALLOW ONLY TRAINED AUTHORIZED PERSONNEL IN THE OPERATING AREA.
5. ANY ELECTRICAL WIRING OR SERVICE WORK MUST BE PERFORMED BY A QUALIFIED ELECTRICIAN. IT MUST MEET ALL STATE AND LOCAL ELECTRICAL CODES.
6. DO NOT ALLOW CHILDREN IN THE AREA OF OPERATION.
7. KEEP HANDS, FEET AND CLOTHING AWAY FROM MOVING PARTS.
8. DISCONNECT AND LOCKOUT POWER BEFORE MAKING ANY ADJUSTMENTS OR PERFORMING ANY SERVICE WORK.
9. DISCONNECT POWER PRIOR TO RESETTING ANY MOTOR OVERLOAD.
10. MAKE CERTAIN ALL ELECTRIC MOTORS ARE GROUNDED.
11. REPLACE ALL WORN OR DAMAGED LABELS IMMEDIATELY.

DC-1379

⑤

DC-1395

⚠ DANGER



ROTATING FLIGHTING!

THIS BIN IS EQUIPPED WITH GRAIN AUGERS WHICH CAN KILL OR DISMEMBER.

KEEP CLEAR OF ALL AUGERS AND NEVER ENTER THIS BIN UNLESS ALL POWER IS DISCONNECTED AND LOCKED OUT.

FAILURE TO DO SO WILL RESULT IN SERIOUS INJURY OR DEATH!

DC-1395

⑥

DC-455

⚠ DANGER

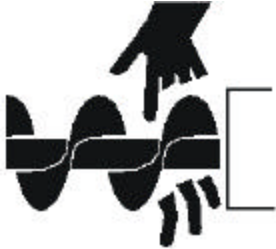

Keep clear of rotating auger and moving parts.

Do not remove or modify guards.

Disconnect and lockout power before servicing.

Failure to do so will result in serious injury or death.

DC-455

SAFETY DECALS

- A. The images below show the location of the decals and safety signs which should appear on the Utility and Bulk Tank Augers.

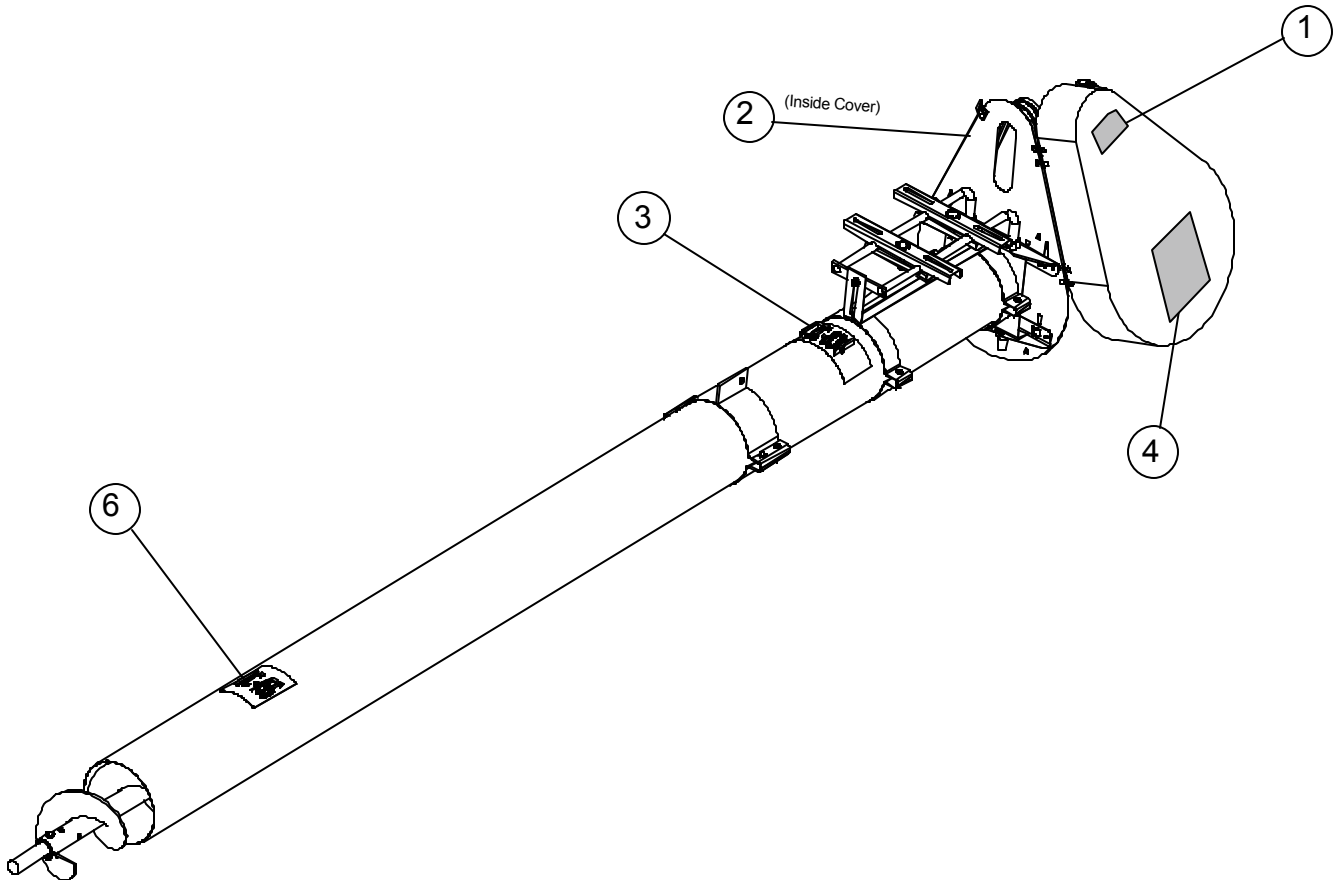
**NOTE**

Please remember safety signs provide important safety information for people working near bin unloading equipment that is in operation. Any safety signs that are worn, missing, illegible or painted over should be replaced immediately. Obtain *FREE* replacements by contacting your dealer.

SAFETY DECALS

- DANGER Sign No. DC-1395 was supplied with your bin unloading equipment. This safety sign should be applied to the side of the bin near the bin opening, so it will be viewed by people entering into the bin storage building. Do not cover any safety signs or any other signs that are already there.
- If the safety sign location suggested is not in full view because of equipment modifications, other equipment in the area, or any reason, then locate the safety sign in a more suitable location.
- Be certain the surface is clean, dry and free of dirt and oil. Peel paper backing from decals and stick into place. The adhesive backing will bond on contact.

NOTE

Please remember, safety signs provide important safety information for people working near bin unloading equipment that is in operation.

DC-1395

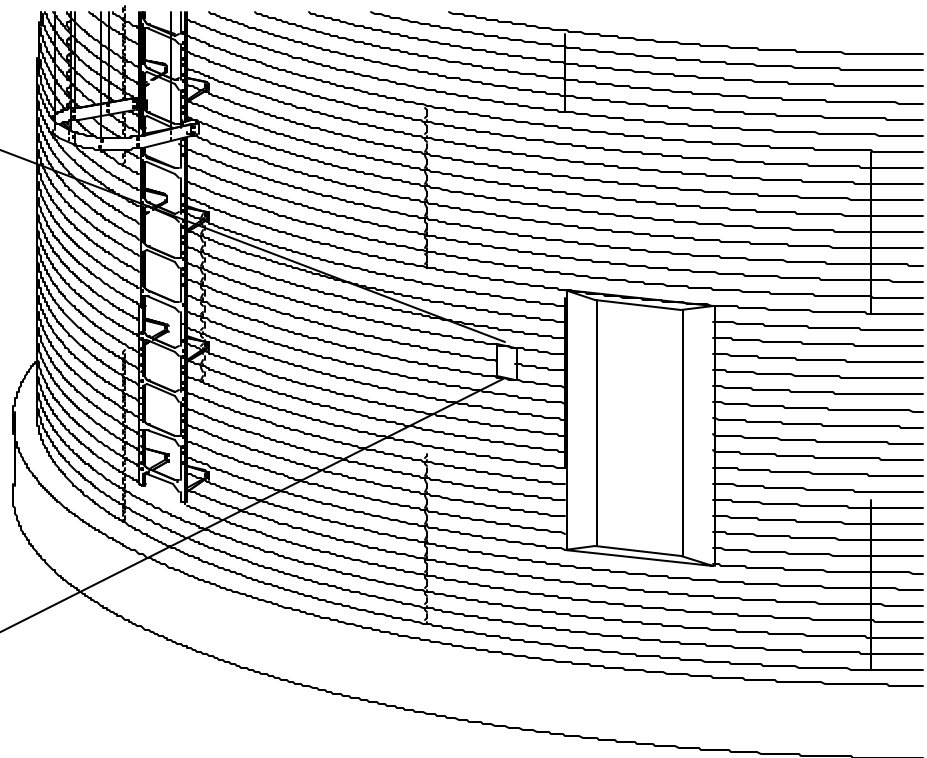

⚠ WARNING

If the Safety Sign cannot be easily read for any reason or has been painted over, replace it immediately. Additional Safety Signs may be obtained *free* of charge from your dealer, distributor, or ordered from the factory.

Order SAFETY SIGN NO. DC-1395

1. General Information

- A. We reserve the right to improve our product whenever possible and practical to do so. We reserve the right to change, improve, and modify products at any time without obligation to make changes, improvements, and modifications on equipment sold previously.
- B. Our products have been designed and manufactured give years of dependable service. The care and maintenance of this machine will affect the satisfaction and service obtained. By observing the instructions and suggestions we have recommended, the owner should receive competent service for many years. If additional information or assistance should be required, please contact the factory or your local dealer.
- C. **Receiving Merchandise and Filing Claims**
 - 1. When receiving merchandise, it is important to check both the quantity of parts and their descriptions with the packing list enclosed within each package. All claims for freight damage or shortage must be made by the consignee within ten (10) days from the date of the occurrence of freight damage. The consignee should accept the shipment after noting the damage or loss.

2. Capacity

- A. The capacities may vary greatly under varying conditions. The following factors play a role in the performance of the auger:
 - Speed
 - Angle of operation
 - Moisture content
 - Amounts of foreign matter
 - Different materials
 - Methods of feeding
- B. For example, a twenty-five percent (25%) moisture could cut capacity by as much as 40% under some conditions.

6" STANDARD DUTY MOTOR MOUNT INSTALLATION

- A. Screw one 3/4" hex nut (18) to the top of each motor mount rod (4).
- B. Slide the motor mount rods (4) through the head plate assembly (6).
- C. Line up slot on the plate of the motor mount rods (4) with the slot on the head plate assembly (6). Fasten them together using 5/16" x 3/4" carriage bolt (13), a flat washer (14), and a nylock nut (15).
- D. Attach a 3/4" hex nut (18) onto the bottom of each motor mount rod (4). Tighten until nut rests against the head plate assembly (6). Adjust top 3/4" hex nuts (18) down until they rests against the top of the head plate assembly (6).
- E. Connect the two-hole flange bearing (8) to head plate assembly (6) using two 7/16" x 1-1/4" bolts (16) with stover nuts (17).
- F. Loosen the top and bottom 3/4" nuts (18) on the motor mount rods (4) to allow the belt guard mounting angles (9) to slide onto the motor mount rods (4). Once the angles are in place tighten nuts to keep mounting angles (9) in position.
- H. Connect the drive stub shaft (3) to flight using two 3/8" x 1-3/4" bolts (19) and stover nuts (22).
- I. Slide head plate assembly (6) over discharge end of tube and tighten the clamps using two 5/16" x 1-1/2" (12) bolts and nylock nuts (15).
- J. Fasten belt guard (5) to mounting angles (9) using four 5/16" x 3/4" carriage bolts (13) with flat washers (14), and nylock nuts (15). **Do Not Fully Tighten.**
- K. Slide discharge end of flighting into the intake end of the tube.
- L. Place head drive stub shaft (3) through head bearing with enough extended to mount pulley (7) with key (23). Tighten lock collar on bearing and tighten setscrews in pulley.
- H. Place the top motor mount clips (1) on top of the motor mount rods (3). Place the bottom motor mount clips (2) directly underneath the motor mount clips (2) and attach each pair together using two 3/8" x 2-1/2" carriage bolts (20) and 3/8" hex nuts (21). **Do not fully tighten so you can adjust them to the motor.**
- I. Attach the motor to the drive unit making sure that the motor is parallel with the auger housing. Use carriage bolts, flatwashers, lock washers, and nuts. Install the motor pulley to the motor. Align the motor pulley and driven pulley by sliding the motor mount clips along the motor mount rods. Tighten the motor mount clips.

NOTE**The motor, motor pulley, and motor hardware are not supplied.**

- J. Install the belt(s) over the pulleys. Belt tension can be fixed by adjusting the height of the motor by turning the 3/4" nuts (27) on the threaded rods.
- O. Once motor height is adjusted correctly, go back and tighten all nuts and bolts.
- P. Close door on belt guard and latch.

6" STANDARD DUTY MOTOR MOUNT INSTALLATION

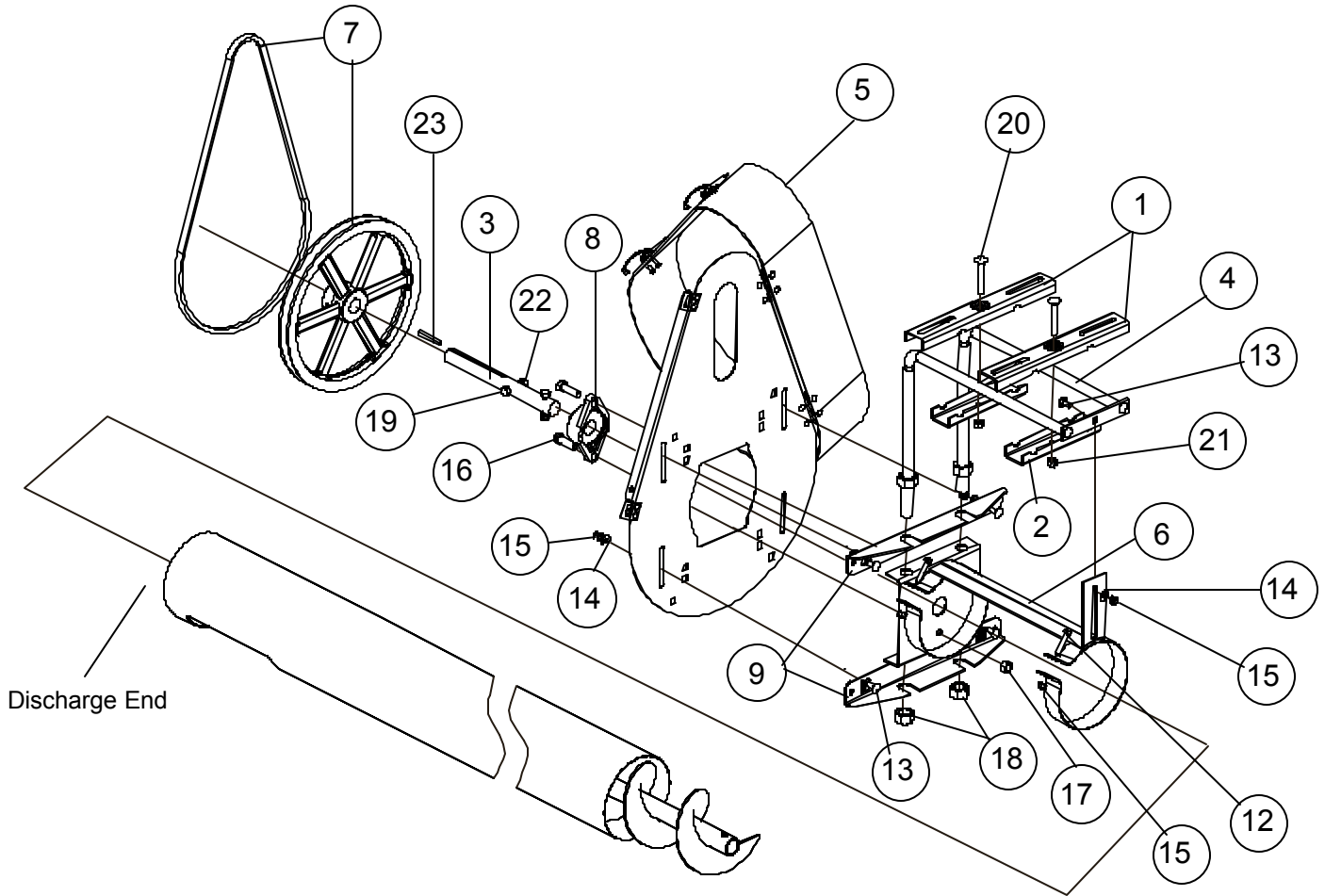

▲ DANGER Lock out all power sources while installing or maintaining equipment.

▲ WARNING Keep all safety devices and shields in place at all times.

8" STANDARD DUTY MOTOR MOUNT INSTALLATION

- A. Screw one 3/4" hex nut (21) to the top of each motor mount rod (6).
- B. Slide the motor mount rods (6) through the head plate assembly (7).
- C. Line up slot on the plate of the motor mount rods (6) with the slot on the head plate assembly (7). Fasten them together using a 5/16" x 3/4" carriage bolt (17), flat washer (20), and a nylock nut (19).
- D. Attach a 3/4" hex nut (21) onto the bottom of each motor mount rod (6). Tighten until nut rests against the head plate assembly (7). Adjust top 3/4" hex nuts (21) down until they rests against the top of the head plate assembly (7).
- E. Connect the two-hole flange bearing (8) to head plate assembly (7) using two 7/16" x 1-1/4" bolts (13) and stover nuts (16).
- F. Loosen the top and bottom nuts on the motor mount rods (6) to allow the belt guard mounting angles (5) to slide onto the motor mount rods (6). Once the angles are in place tighten nuts to keep mounting angles (5) in position.
- G. Connect head drive stub shaft (3) to flight using two 7/16" x 2-1/2" bolts (14) with stover nuts (16).
- H. Slide head plate assembly (7) over discharge end of tube and tighten each clamp using two 5/16" x 1-1/2" (18) bolts with nylock nuts (19).
- I. Fasten belt guard (9) to mounting angles (5) using four 5/16" x 3/4" carriage bolts (17) with flat washers (20), and nylock nuts (19). **Do Not Fully Tighten.**
- J. Slide discharge end of flighting into the intake end of the tube.
- K. Place head drive stub shaft (3) through head bearing with enough extended to mount pulley (10) with key (24). Tighten lock collar on bearing and tighten setscrews in pulley.
- L. Place the top motor mount clips (1) on top of the motor mount rods (6). Place the bottom motor mount clips (2) directly underneath the motor mount clips (1) and attach each pair together using two 3/8" x 2-1/2" carriage bolts (22) and 3/8" hex nuts (23). **Do not fully tighten so you can adjust them to the motor.**
- M. Attach the motor to the drive unit making sure that the motor is parallel with the auger housing. Use carriage bolts, flatwashers, lock washers, and nuts. Install the motor pulley to the motor. Align the motor pulley and driven pulley by sliding the motor mount clips along the motor mount rods. Tighten the motor mount clips.

NOTE**The motor, motor pulley, and motor hardware are not supplied.**

- N. Install the belt(s) over the pulleys. Belt tension can be fixed by adjusting the height of the motor by turning the 3/4" nuts (21) on the threaded rods.
- O. After motor height is properly adjusted go back and tighten all bolts and nuts.
- P. Close door on belt guard and latch.

8" STANDARD DUTY MOTOR MOUNT INSTALLATION

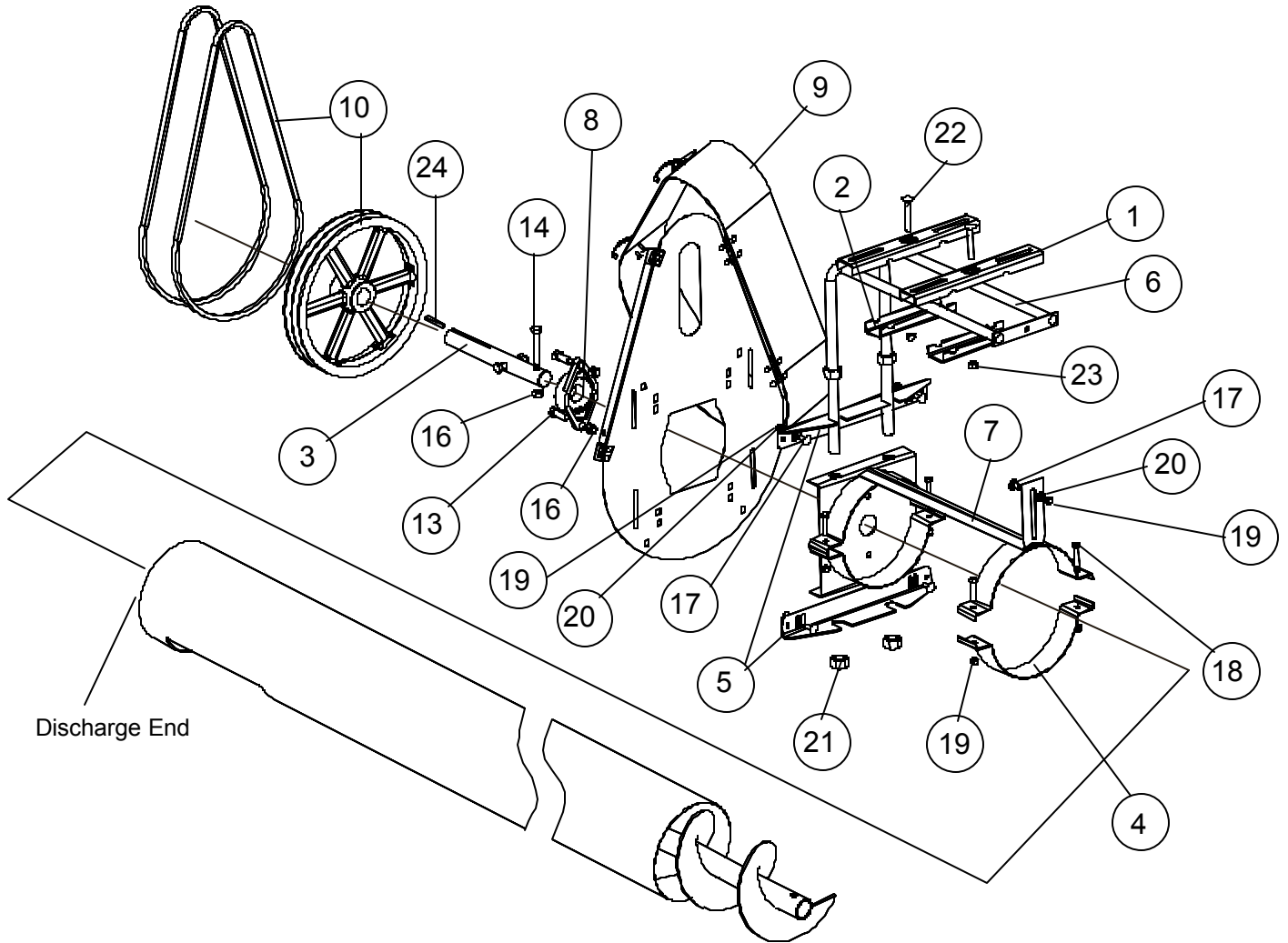

▲ DANGER Lock out all power sources while installing or maintaining equipment.

▲ WARNING Keep all safety devices and shields in place at all times.

8" HEAVY DUTY MOTOR MOUNT INSTALLATION

- A. First, connect the head stub shaft (12) to the short flight using two 7/16" x 2-1/2" bolts with nylock nuts.
- B. Connect the four-hole flange bearing with lock collar (1) and the head plate (10) together using four 7/16" x 1-1/4" bolts (13) with stover nuts (15).
- C. Attach the head plate (10) to the tube flange using eight 5/16" x 1" bolts (16), split lock washers (19), and hex nuts (18).
- D. Connect side plates (4) and (5) to head plate (10) using four 1/2" x 1" bolts (21), split lock washers (23), and nuts (22). Also, at the same time attach the left and right belt guard brackets (9) using the same bolts.
- E. Spin a 3/4" nut (28) on the threaded rods of each strap and rod assembly (6). Insert threaded rods through holes in side plates (4) & (5) and add four more 3/4" nuts (28). **Do Not Fully Tighten.**
- F. Place rods (8) on straps & rod assembly (6) then place top straps (7) over rods (8). Secure rods and straps in place using six 3/8" x 1-1/2" bolts (25), twelve 3/8" flat washers (27) and six hex nuts (26).
- G. Place the top motor mount clips (3) on top of the motor mount rods (8). Place the bottom motor mount clips (2) directly underneath the top motor mount clips (3) and attach each pair together using two 3/8" x 3" carriage bolts (24) and 3/8" hex nuts (26). **Do not fully tighten so you can adjust them to the motor.**
- H. Attach belt guard (33) to belt guard mounting angles (9) using four 5/16" x 3/4" carriage bolts (17) with flat washers (20) and hex nuts (18).
- I. Slide bearing lock collar (1) over head stub shaft. Leave enough stub exposed to mount pulley (11) on stub with drive key (29). Tighten bearing lock collar next to bearing and tighten set screws in pulley. Install pulley (11) on head stub shaft.
- J. Attach the motor to the drive unit making sure that the motor is parallel with the auger housing. Use carriage bolts, flatwashers, lock washers, and nuts. Install the motor pulley to the motor. Align the motor pulley and driven pulley by sliding the motor mount clips along the motor mount rods. Tighten the motor mount clips.

NOTE**The motor, motor pulley, and motor hardware are not supplied.**

- K. Install the belt(s) over the pulleys. Belt tension can be fixed by adjusting the height of the motor by turning the 3/4" nuts (28) on the threaded rods.
- L. After everything has been adjusted correctly, go back and tighten all nuts and bolts.
- M. Close door on belt guard and latch.

8" HEAVY DUTY MOTOR MOUNT INSTALLATION

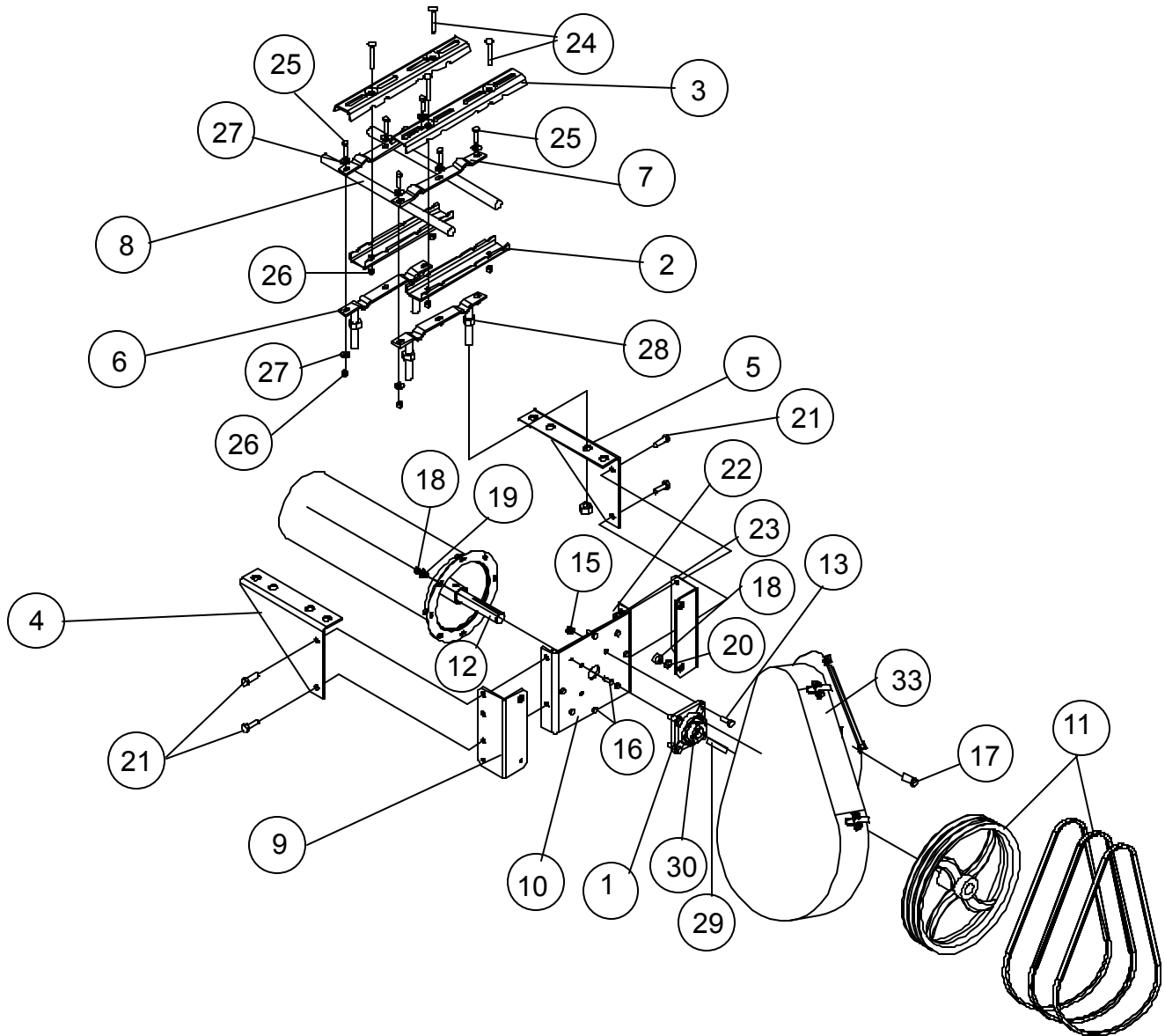

▲ DANGER Lock out all power sources while installing or maintaining equipment.

▲ WARNING Keep all safety devices and shields in place at all times.

10" STANDARD DUTY MOTOR MOUNT INSTALLATION

- A. Screw one 7/8" hex nut (27) to the top of each motor mount rod (7).
- B. Slide the motor mount rods through the head plate assembly (6).
- C. Line up slot on the plate end of the motor mount rods (7) with the slot on the head plate assembly (6). Fasten them together using 3/8" x 1" carriage bolt (19), a flat washer (22), and a nylock nut (21).
- D. Attach a 7/8" hex nut (27) onto the bottom of each motor mount rod (7). Tighten until nut rests against the bottom of the head plate assembly (6). Adjust top 7/8" hex nuts (27) down until they rests against the top of the head plate assembly (6).
- E. Connect the four-hole flange bearing (4) to head plate assembly (6) using four 1/2" x 1-1/2" bolts (17) with split lock washers (25) and hex nuts (26).
- F. Loosen the top and bottom 7/8" nuts (27) on the rods (7) to allow the belt guard mounting angles (5) to slide onto the motor mount rods (7). Once the angles are in place tighten nuts to keep rods in position.
- G. Connect head drive stub shaft (9) to flight using two 1/2" x 3" bolts (18) with stover nuts (24).
- H. Slide head plate assembly (6) over discharge end of tube and tighten the halfband clamps (1) using four 5/16" x 1-1/2" bolts (13) with nylock nuts (15). Slip bearing lock collar (not shown) over head drive stub.
- I. Fasten belt guard (8) to mounting angle (5) using four 5/16" x 3/4" carriage bolts (14), flat washers (16), and nylock nuts (15). **Do not fully tighten so you can adjust it later.**
- J. Place the top motor mount clips (3) on top of the motor mount rods (7). Place the motor mount clips (2) directly underneath the rods and top clips and fasten using four 3/8" x 3" carriage bolts (23) and hex nuts (20). **Do not fully tighten so you can adjust them to the motor.**
- K. Place head drive stub shaft (9) through head bearing with enough extended to mount pulley (10) with key. Place pulley o head stub shaft with setscrew facing away from the head plate. Tighten bearing with lock collar and tighten setscrews with a hex head wrench to secure it to the drive shaft. Tighten bearing with lock collar and tighten setscrews in pulley.
- L. Attach the motor to the drive unit making sure that the motor is parallel with the auger housing. Use carriage bolts, flatwashers, lock washers, and nuts. Install the motor pulley to the motor. Align the motor pulley and driven pulley by sliding the motor mount clips along the motor mount rods. Tighten the motor mount clips.
- M. Install the belt(s) over the pulleys. Belt tension can be fixed by adjusting the height of the motor by turning the 7/8" hex nuts (27) on the threaded rods.
- N. Close door on belt guard and latch.
- O. After everything has been adjusted, go back and tighten all nuts and bolts.

10" STANDARD DUTY MOTOR MOUNT INSTALLATION

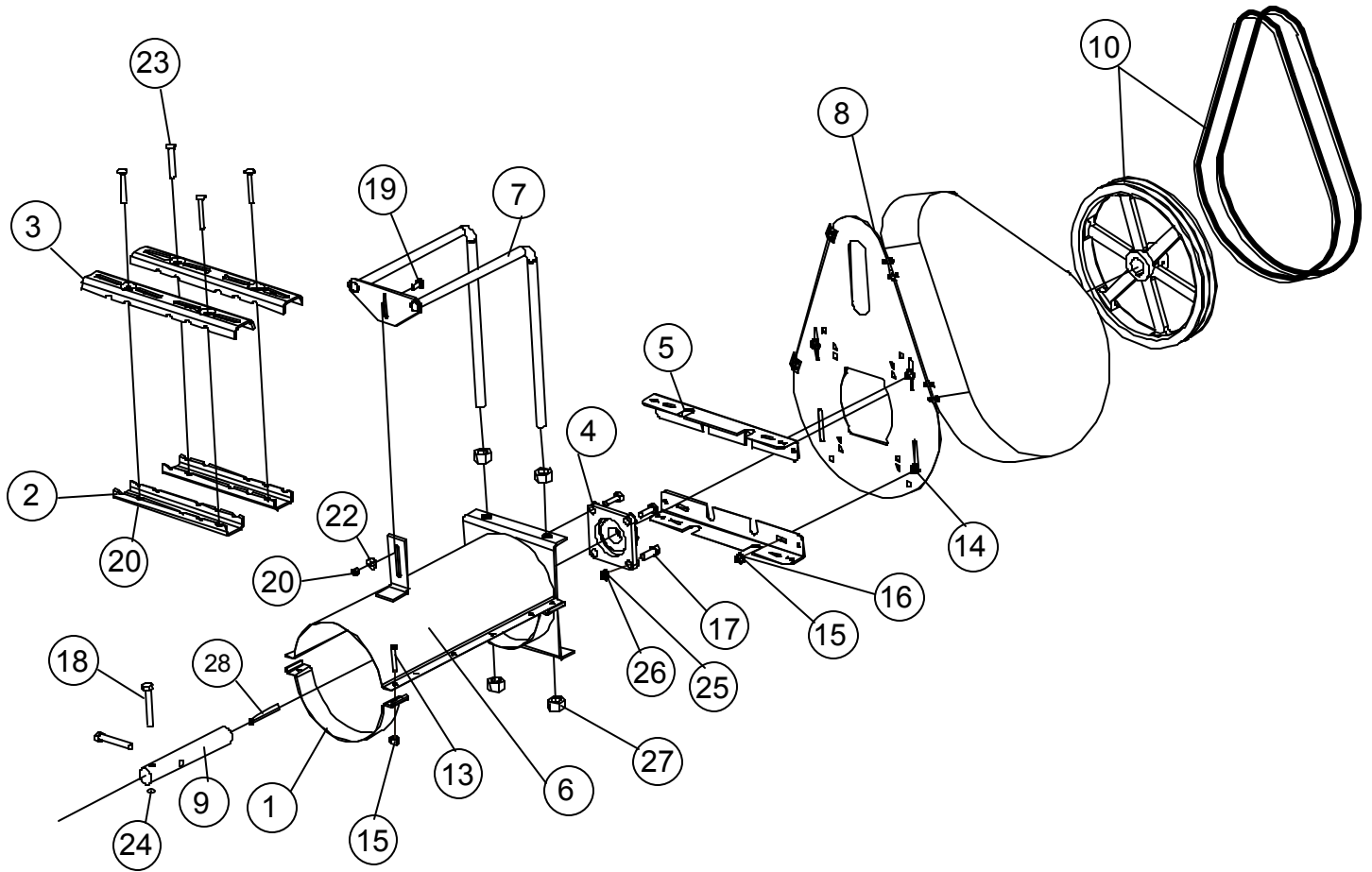

▲ DANGER Lock out all power sources while installing or maintaining equipment.

▲ WARNING Keep all safety devices and shields in place at all times.

10" HEAVY DUTY MOTOR MOUNT INSTALLATION

- A. First, connect the head stub shaft (42) to the flight using two 1/2" x 3-1/2" bolts (41) with nylock nuts (40).
- B. Connect the four-hole flange bearing with lock collar (3) to the head plate (12) together using four 1/2" x 1-1/2" bolts (28) with stover nuts (40).
- C. Attach the head plate (12) to the tube flange using eight 3/8" x 1" bolts (23) with split lock washers (27), and hex nuts (25).
- D. Connect side plates (5) and (6) to head plate (12) using four 1/2" x 1-1/4" bolts (29), lock washers (39), and hex nuts (30). **Also, at the same time, attach the belt guard brackets (16) using the same bolts.**
- E. Spin a 3/4" nut (38) on the threaded rods of each strap and rod assembly (7). Insert threaded rods through holes in side plates (5) & (6) and add four more 3/4" nuts (38). **Do not fully tighten so you can adjust them later.**
- F. Place rods (4) in strap and rod assemblies (7) and secure with top straps (8) using eight 3/8" x 1-1/2" bolts (24) with two flat washers (26) and one hex nut (25) on each bolt.
- G. Clamp belt guard mounting angle (9) to rod ends (4) with clamp bar (10) using four 5/16" x 1-3/4" bolts (34) with hex nuts (36).
- H. Attach belt guard back (15) to belt guard mounting angles (16) using four 5/16" x 3/4" carriage bolts (33) with flat washers (37) and nylock nuts (35).
- I. Slide bearing lock collar over head stub shaft. Leave enough stub exposed to mount pulley (18) on stub with drive key. Tighten bearing lock collar next to bearing and tighten set screws in pulley.
- J. Place 3/8" square key (21) into the keyway located on the head stub shaft. Place pulley (18) onto head stub with setscrew facing away from the head plate. Once the pulley (18) is positioned correctly, tighten the setscrews with a hex head wrench to secure it to the drive shaft.
- K. Place the top motor mount clips (2) on top of the motor mount rods (4). Place the bottom motor mount clips (1) directly underneath the top motor mount clips (2) and attach each pair together using two 3/8" x 3" carriage bolts (22) and 3/8" hex nuts (25). **Do not fully tighten so you can adjust them to the motor.**
- L. Attach the motor to the drive unit making sure that the motor is parallel with the auger housing. Use carriage bolts, flatwashers, lock washers, and nuts. Install the motor pulley to the motor. Align the motor pulley and driven pulley by sliding the motor mount clips along the motor mount rods. Tighten the motor mount clips.

NOTE**The motor, motor pulley, and motor hardware are not supplied.**

- M. Install the belt(s) over the pulleys. Belt tension can be fixed by adjusting the height of the motor by turning the 3/4" nuts (38) on the threaded rods.
- N. Connect belt guard (14) by bolting belt guard clamp bar (13) to mounting angle (9) using 1/4" x 5-1/2" bolts (31) with hex nuts (32). Attach second clamp bar (11) to belt guard mounting brackets (16) using 1/4" x 5-1/2" bolts.
- O. Go back and tighten all bolts and nuts.

10" HEAVY DUTY MOTOR MOUNT INSTALLATION

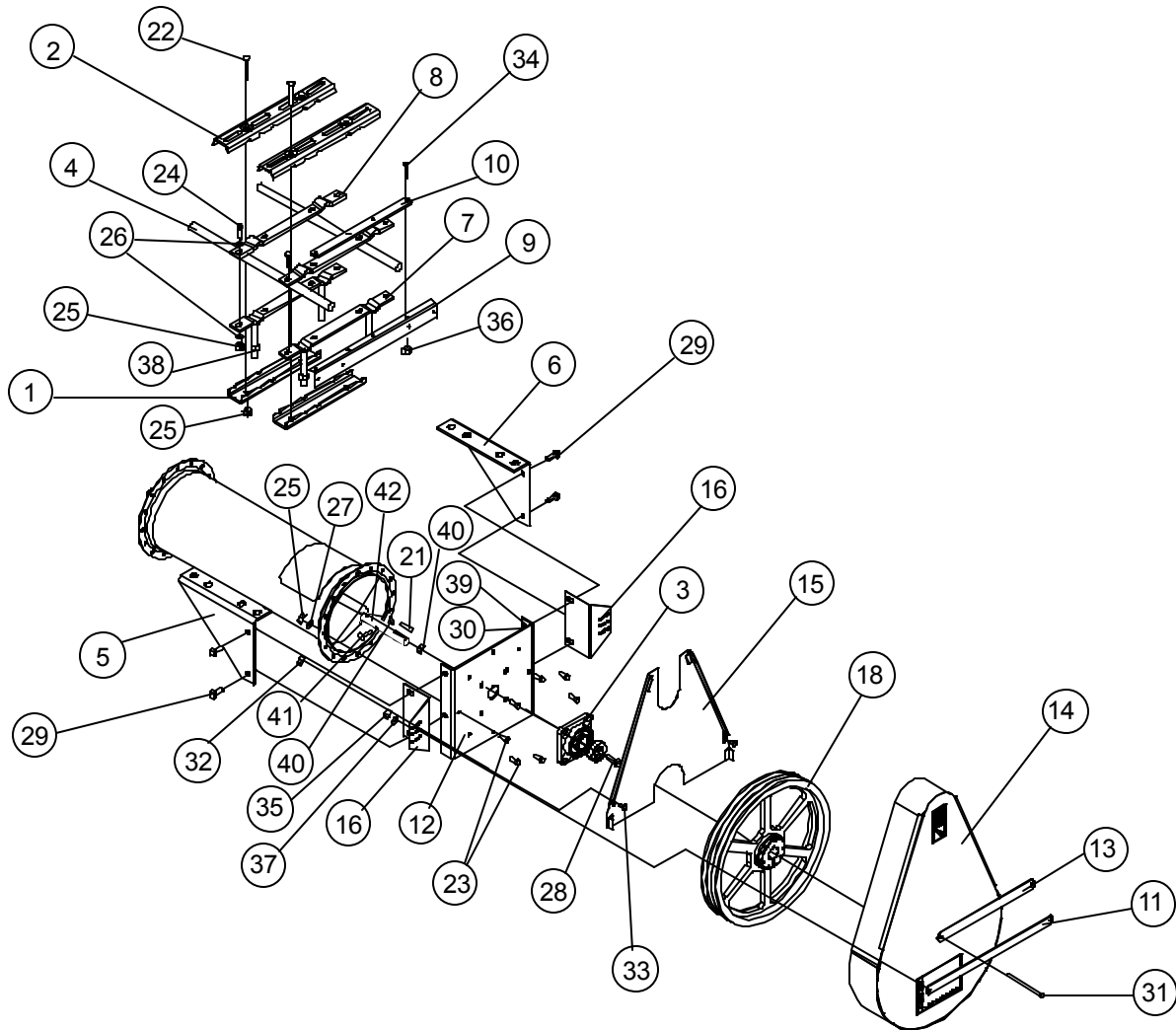

▲ DANGER Lock out all power sources while installing or maintaining equipment.

▲ WARNING Keep all safety devices and shields in place at all times.

12" HEAVY DUTY MOTOR MOUNT INSTALLATION

- A. First, connect the head stub shaft (31) to the flight using two 5/8" x 4" bolts (29) with nylock nuts (30).
- B. Connect the four-hole flange bearing with lock collar (6) to the head plate (7) using four 5/8"-11 x 2" bolts (32) lock washers (33), and hex nuts (34).
- C. Attach the head plate (7) to the tube flange using twelve 3/8"-16 x 1" bolts (35), flat washers (20), lock washers (36), and hex nuts (19).
- D. Connect the left and right side plates (12) & (13) to the head plate (7) using four 1/2" x 1" bolts (21) with nuts (22).
- E. Thread a 3/4" nut (27) onto each threaded section of the strap and rod assemblies (8). Insert the threaded rods through the holes in the top of the side plates (12) & (13). Thread a 3/4" nut (27) onto the end of each rod to fasten rod assemblies in place. Do not tighten.
- F. Place rods (3) on straps & rod assembly (8) then place top straps (4) over rods (3). Secure rods and straps in place using eight 3/8" x 1-1/2" bolts (17), sixteen 3/8" flat washers (20) and eight hex nuts (19).
- G. Clamp belt guard mounting angle (9) to the rods (3) using the clamp bar (10) and four 5/16" x 1-3/4" bolts (25) and four 5/16" hex nuts (26).
- H. Place 3/8" square key (?) into the keyway located on the head stub shaft. Place pulley (14) onto head stub with setscrew facing away from the head plate.
- I. Once the pulley (15) is positioned correctly, tighten the setscrews with a hex head wrench to secure it to the drive shaft.
- J. Place the top motor mount clips (2) on top of the motor mount rods (3). Place the bottom motor mount clips (1) directly underneath the motor mount clips (2) and attach each pair together using two 3/8" x 3" carriage bolts (18) and 3/8" hex nuts (19). **Do not fully tighten so you can adjust them to the motor.**
- K. Attach the motor to the drive unit making sure that the motor is parallel with the auger housing. Use carriage bolts, flatwashers, lock washers, and nuts. Install the motor pulley to the motor. Align the motor pulley and driven pulley by sliding the motor mount clips along the motor mount rods. Tighten the motor mount clips.

NOTE**The motor, motor pulley, and motor hardware are not supplied.**

- L. Install the belt(s) over the pulleys. Belt tension can be fixed by adjusting the height of the motor by turning the 3/4" nuts (27) on the threaded rods.
- M. Attach the belt guard to the belt guard angle. Using the 16" clamp bar (11) and two 1/4" x 5" bolts (23) with hex nuts (24).
- N. Go back and tighten all nuts and bolts.

12" HEAVY DUTY MOTOR MOUNT INSTALLATION

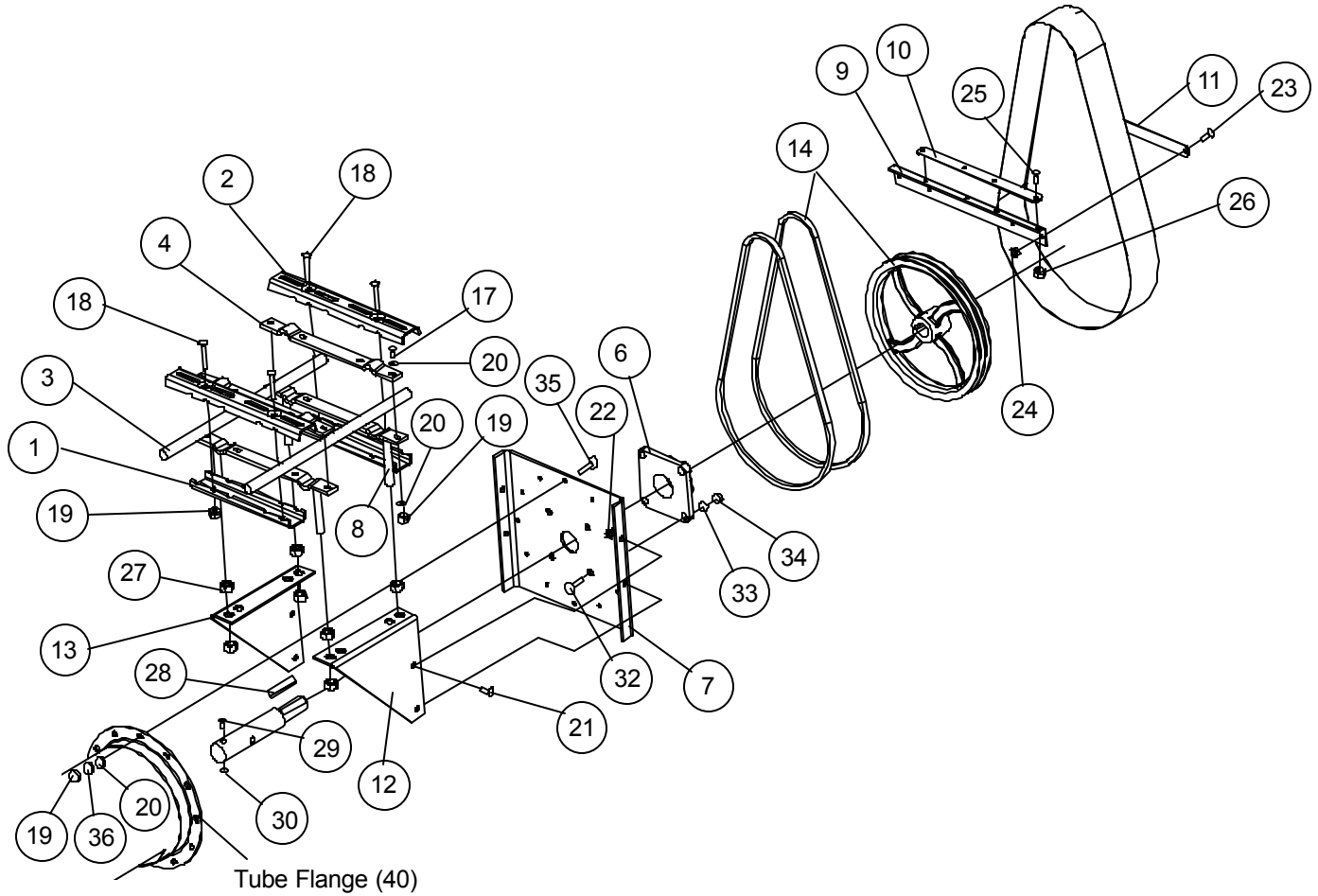

▲ DANGER Lock out all power sources while installing or maintaining equipment.

▲ WARNING Keep all safety devices and shields in place at all times.

OUTLET CUTTING GUIDELINES

1. Before ordering, predetermine the location of the outlet drops. Make sure the outlet drops do not interfere with the connecting band locations.
2. When an outlet opening is cut, that section of tube loses much of it's strength therefore additional support may be necessary. (See page 22 for more information.)
3. If you have internal bearing flighting, outlets may be cut below internal bearings but a hole must cut in the spout halfband allow access to internal hanger bearing.
4. We recommend removing flight before cutting the tube otherwise flight will be notched and/or rough edges will occur. This may not significantly impact the performance of the auger, but burrs and metal chips should be removed or abnormal wear will result. Also, grind down any rough edges on tubing for a better fit and smoother operation.
5. Carefully measure your outlet before cutting. Follow the recommended guidelines as shown below. It is very important that the opening be large enough not to reduce capacity, but small enough so the outlet can be covered securely by the spout.

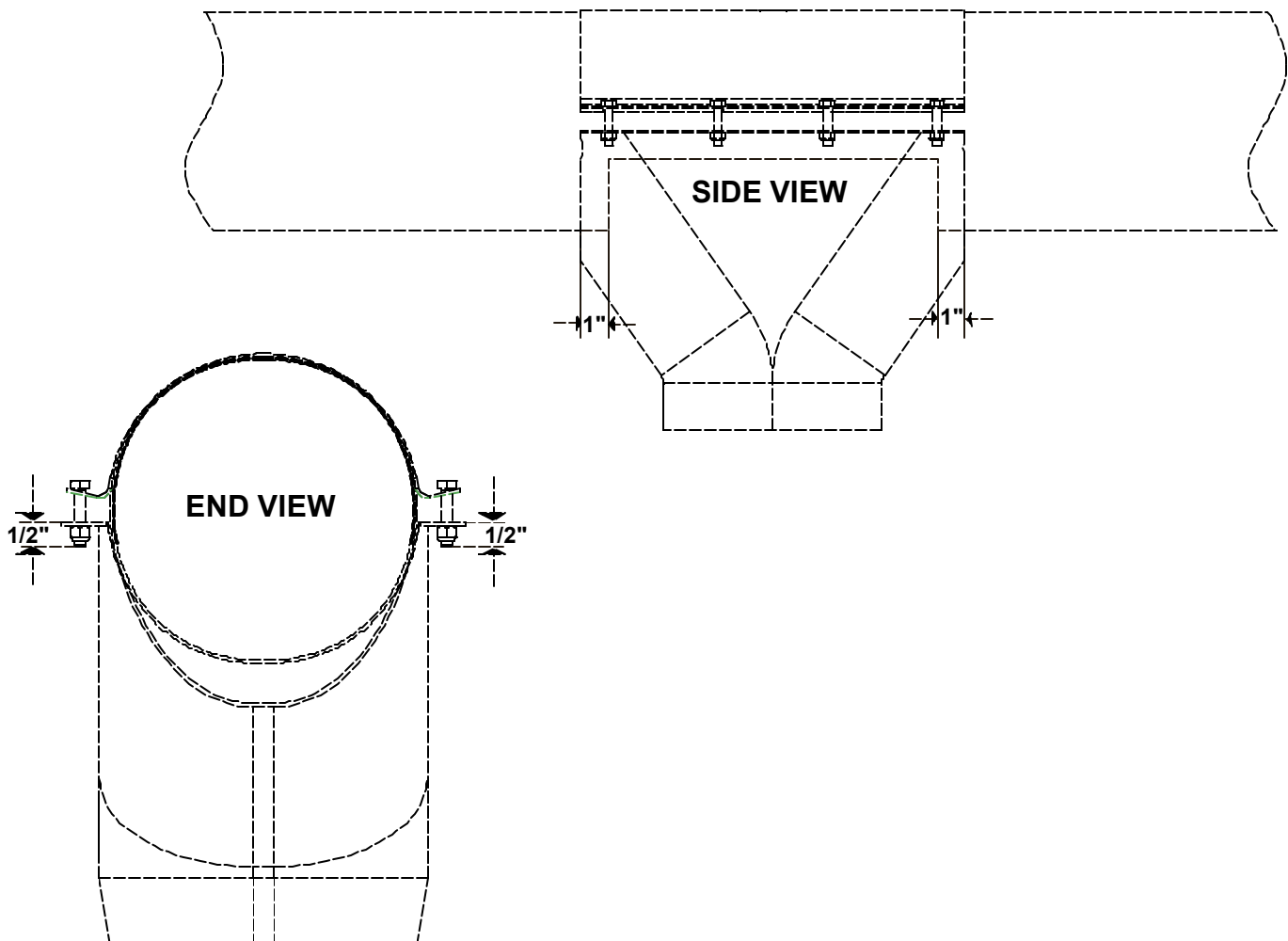

ENCLOSED SLIDE GATES WITH RACK AND PINION CONTROL

1. Follow cutting guidelines on page 18.
2. Attach spout to tube with backband.
3. Remove smaller outside nut from the rack and pinion connecting rod and insert rod through the hole in the angle on the slide gate and secure with the smaller outside nut.
4. Fully close slide gate. Using the pulley, adjust the halfbands so they are located at the end of the control rod farthest from the spout. Then tighten the halfbands to the tube.
5. Wrap rope or cable around the pulley, doubling it to prevent slippage.

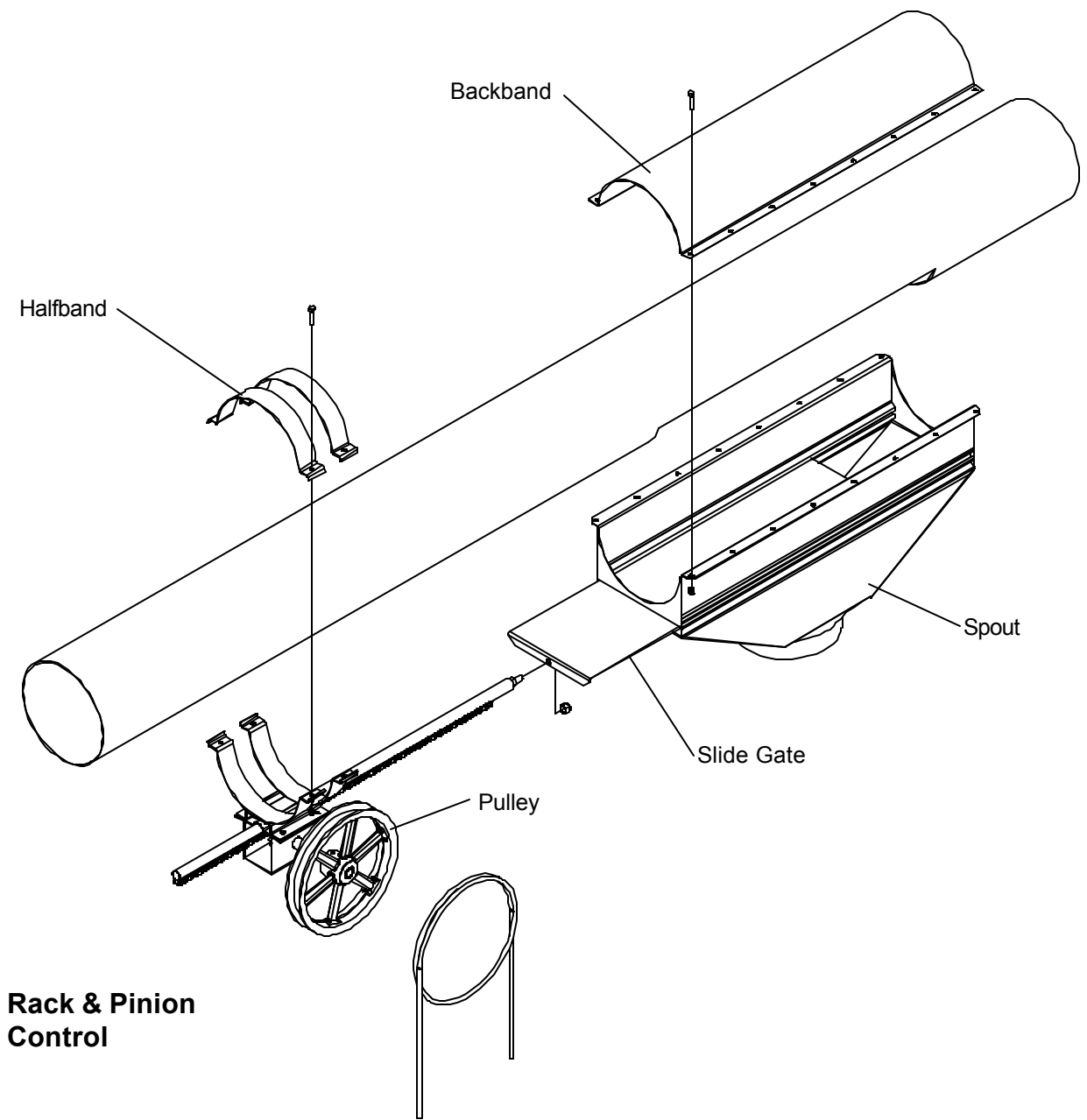

Rack & Pinion Control

ENCLOSED SLIDE GATES WITH RACK AND PINION CONTROL

1. Follow cutting guidelines on page 18.
2. Attach spout to tube with backband.
3. Remove smaller outside nut from the rack and pinion connecting rod and insert rod through the hole in the angle on the slide gate and secure with the smaller outside nut.
4. Fully close slide gate. Using the pulley, adjust the halfbands so they are located at the end of the control rod farthest from the spout. Then tighten the halfbands to the tube.
5. Wrap rope or cable around the pulley, doubling it to prevent slippage.

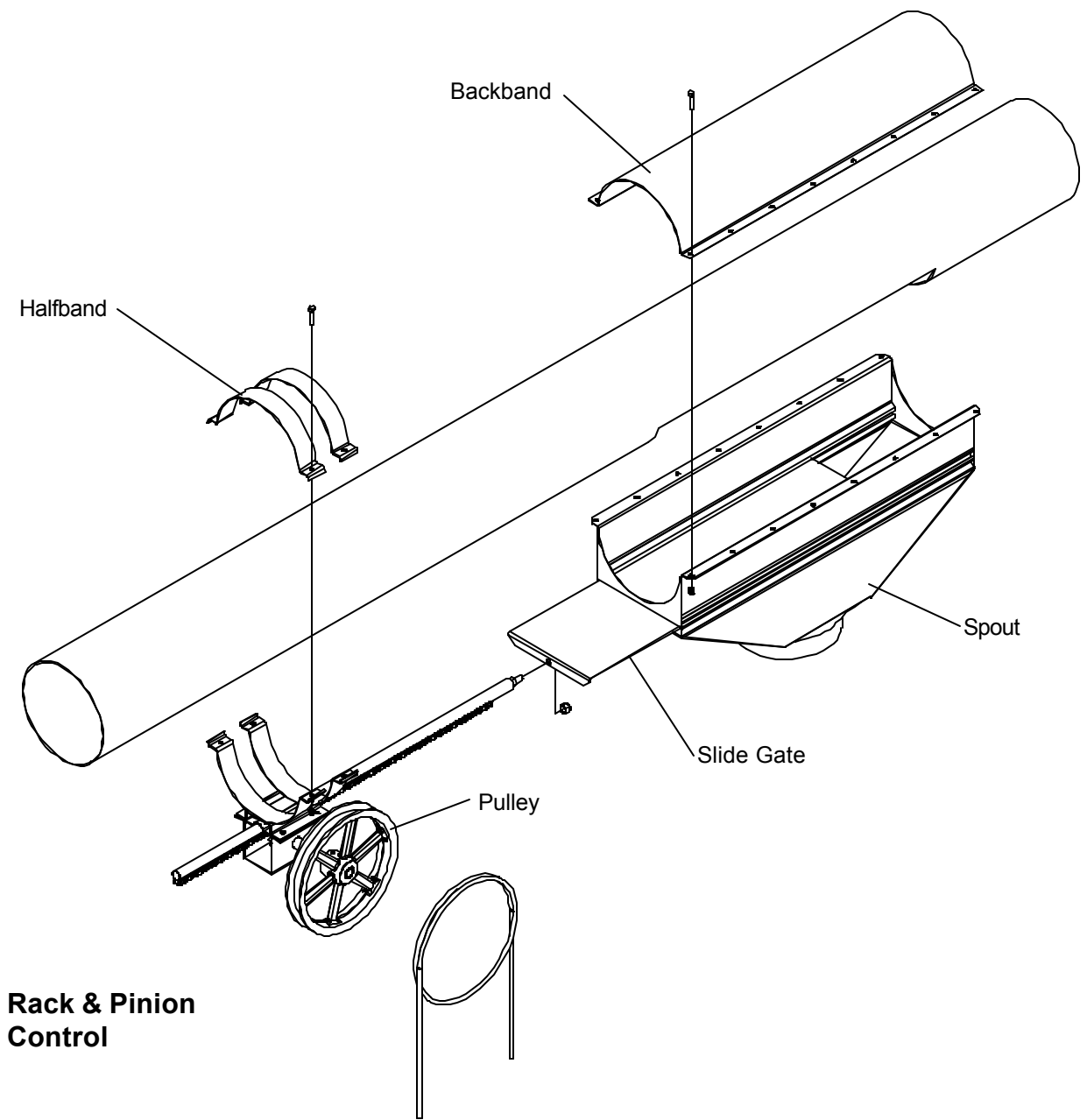

INLET HOPPERS WITH BEARINGS

1. Fasten bearing to the outside of the hopper.
2. Slide tube and fighting assembly through the band and into the hopper, inserting intake stub through the hole in the hopper and bearing.
3. Tighten bearing lock collar on intake stub outside of hopper.
4. Tighten band onto end of tube.
5. Install cover where applicable.

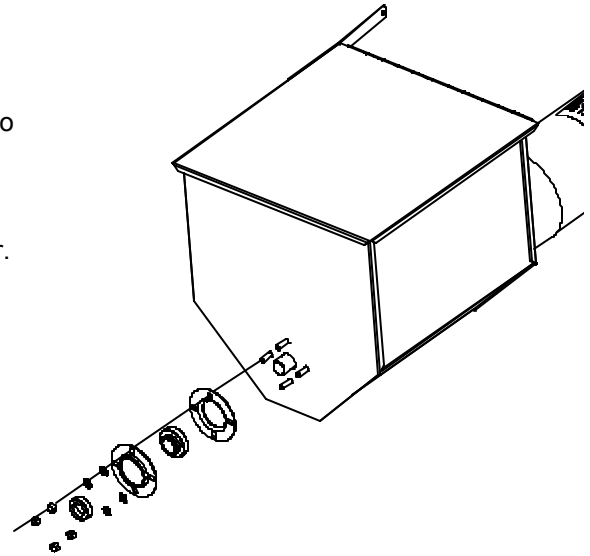

INTAKE GUARD & CONTROL GATE

1. If an optional control gate is being used, slide control gate sleeve over flight and inside of auger tube.
2. Slide the intake guard over the auger tube. Insert stub through the bearing leaving **at least a 1/2" space between the flight and bearing**. Bolt the guard halfband to the tube.
3. For units with control gates, loosely attach halfband with loop onto the tube. Insert small handle through the small loop on halfband.
4. Insert 5/16" x 1" capscrew through the hole in the handle and into the square nut on control gate sleeve. Capscrew should be tightened until it is in firm contact with control gate sleeve, then tighten an additional half turn more to lock handle in place. **Do not over-tighten.**
5. Adjust handle to desired position. Fully tighten the halfbands to fasten handle to tube.

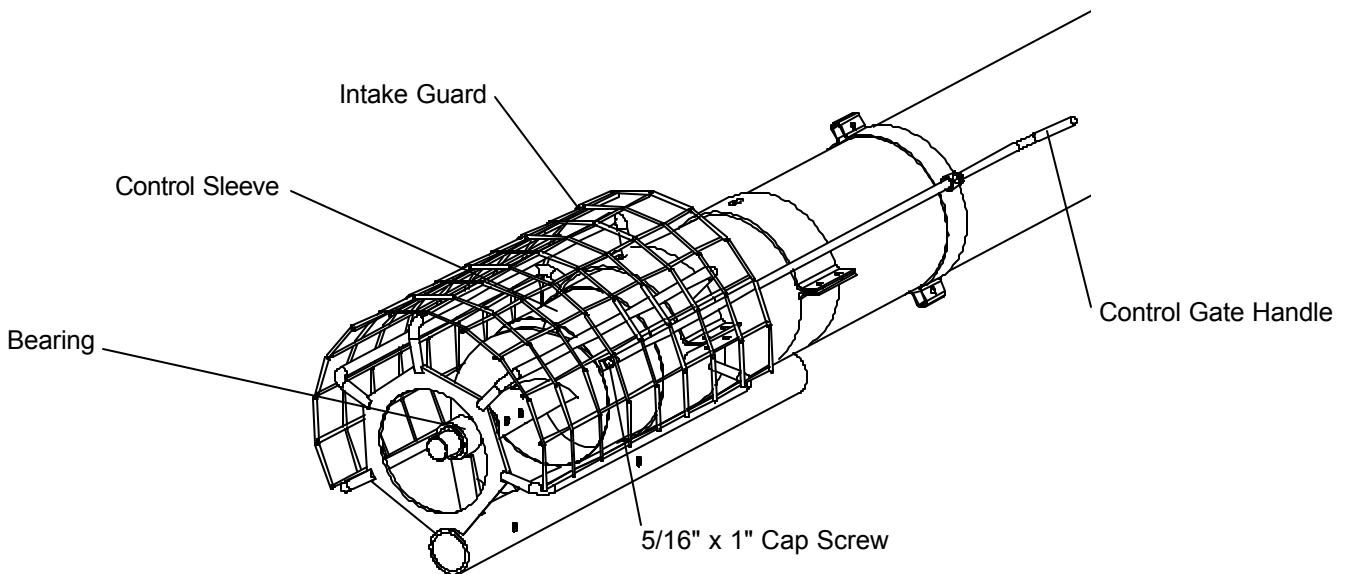

CONNECTING FLIGHT AND TUBING

Systems that require the joining of two or more sections of tube and flight assemblies should be laid out and sorted to determine what sections can be assembled prior to installation in the system.

Standard Assemblies without Bearings

1. Slide connecting band onto one of the tubes to be connected.
2. Slide flighting out of tubes enough to connect together using four bolts and one connecting stub. (See bolt chart below for bolt sizes.)
3. Slide tubes together until they rest firmly against each other.
4. Slide connecting band over tubes so that it is resting equally on both tubes and tighten bolts.

BOLT CHART	UNIT SIZE	BOLT SIZE
	6.0"	3/8" x 1-3/4"
	8.0"	7/16" x 2-1/2"
	10.0"	1/2" x 3"
	12.0"	5/8" x 4"

NOTE: All bolts are Grade 5 with locknuts.

Assemblies with Internal Bearings

1. Slide connecting band onto one of the tubes. Slide flighting out of tubes enough to attach them together.
2. Attach flight connecting stub to lower flight. Place internal bearing hanger onto flight connecting stub.
3. Connect the flighting together. Slide tube housings together so they are butted together.
4. Slide connecting band so it is positioned equally on both tube housings.
5. Detach the bands that are over the bearing access area. Grab the internal bearing hanger stem and rotate the bearing until it lines up with the 3/4" hole on the top of the auger housing.
6. Make sure the bearing is centered between the ends of the auger flighting by looking through the bearing hanger access area and fasten bearing hanger to housing.

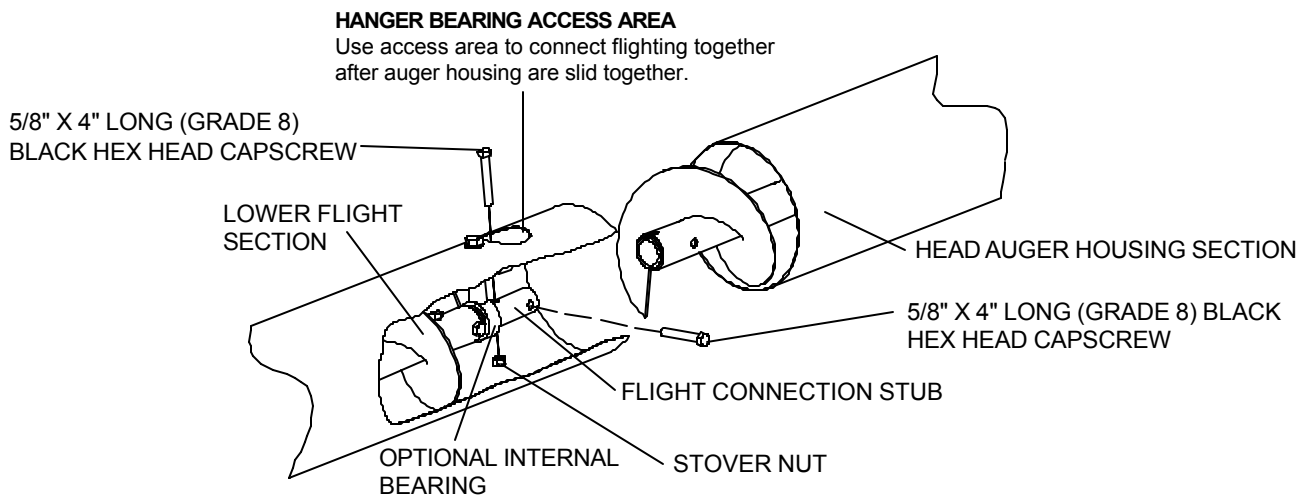

SPOUTING, FITTINGS, AND TRUSS KITS

Spouting and Fittings

To connect sections of spouting or to connect fittings to spouting, use one or all of the following procedures:

1. Spouting to Spouting - Slide flange rings over ends of spouting to be joined and weld in place. Make sure flanges are mounted squarely. Join flanges and bolt together.
2. Spouting to Fitting - Install ring flange on spouting as in Step 1. Join to flange on fitting (valve, dead head, slip joints, etc.)
3. Flange Clamps - Fit each half over flanges and tighten with bolts provided.
4. Quick-Connect Flange Clamps - Fit each half over flange and tighten bolt. Do not use in location where permanent unions are required.

Truss Kits

Truss rod kits are designed to provide support for support for spouting and certain auger sections. There are two different kits available for trussing. 20' to 30' Span Kits and 30' to 40' Span kits for spouting only. See the instructions that are included with your kit for proper installation.

SAMPLE CUSTOM AUGER CONFIGURATIONS

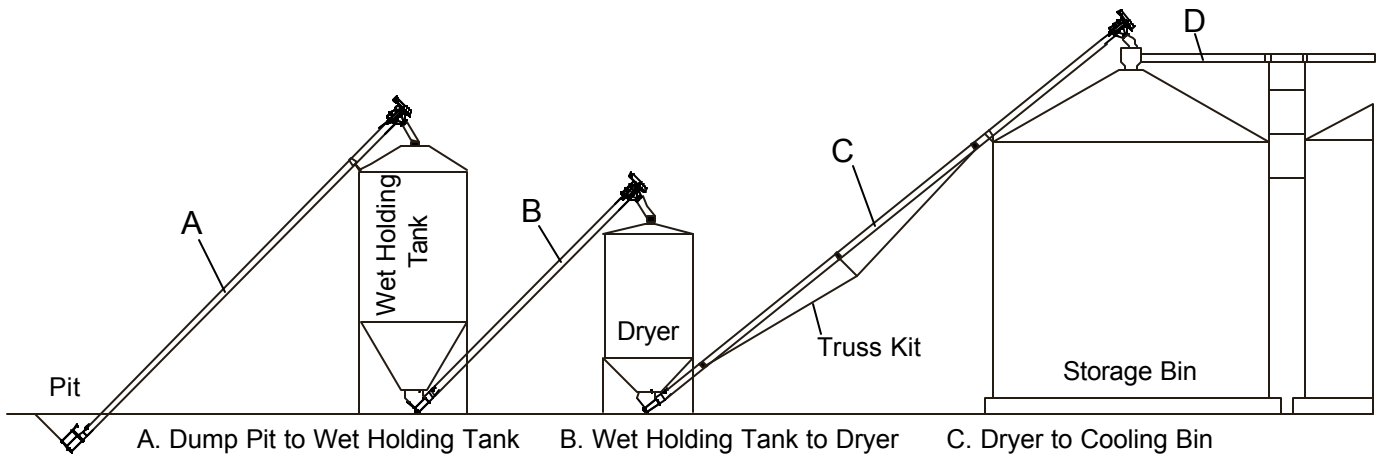

Note: This example uses bucket elevators.

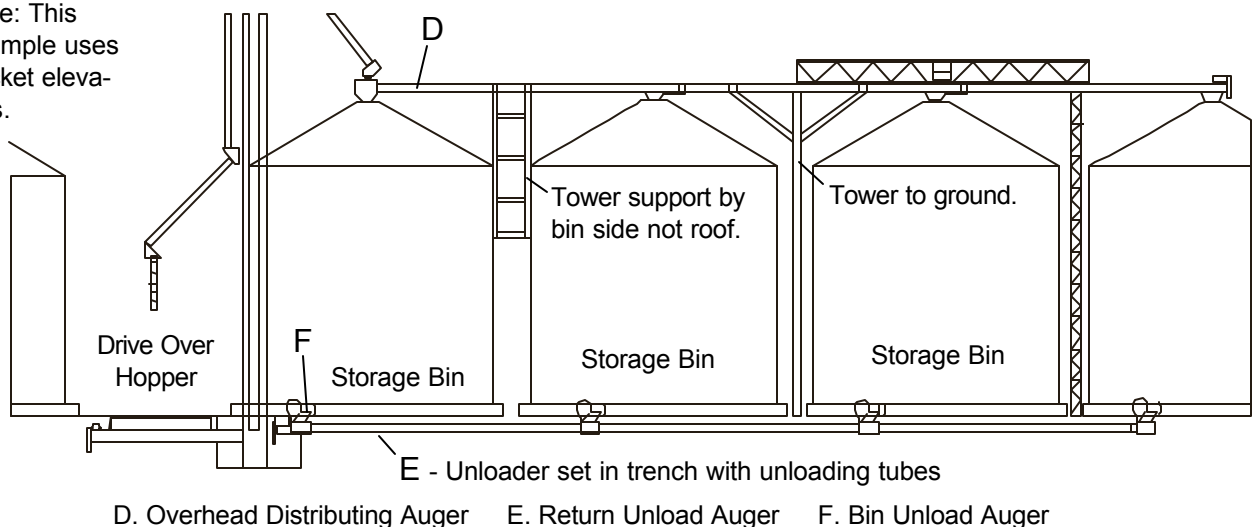

1. Power Source

- A. Use electric motors that operate at 1750 R.P.M.
- B. Electric motors and controls should be installed by a qualified electrician and must meet the standards set by the National Electrical Code and all local and state codes.

▲ WARNING

Electrical controls and wiring should be installed by a qualified electrician. The motor disconnect switches and conductor cables should comply with the National Electrical Code and any local codes which apply. Motor starting control stations should be so located that the operator can see that all personnel are clear of the equipment.

- C. A magnetic starter should be used to protect your motor when starting and stopping. It should stop the motor in case of power interruption, conductor fault, low voltage, circuit interruption, or motor overload. Then the motor must be restarted manually. Some motors have built-in thermal overload protection. If this type motor is used, use only those with a manual reset.

▲ WARNING

A Main Power Disconnect Switch capable of being locked only in the OFF position shall be provided. This shall be locked whenever work is being done on the auger.

CAUTION

Disconnect power before resetting motor overloads.

▲ WARNING

Make sure all electrical motors are grounded.

▲ WARNING

Reset and motor starting and stopping controls must be located so that the operator has full view of the entire operation.

▲ DANGER

Lock out power source before adjusting , servicing, or cleaning the machinery.

▲ DANGER

Keep all safety guards and shields in place.

2. Maintenance

- A. The flange bearings on the head and tail ends of all units should be lubricated on frequent intervals.

▲ DANGER

Never clean, adjust, or lubricate a machine that is in operation.

1. Start-up and Break-In



ALWAYS keep ALL guards and shields in place, until all the power is disconnected and locked out.

- A. Make sure all belts are tensioned properly.
- B. Make sure ALL shields are in place and that the belt(s) and pulley(s) are able to move freely.
- C. Double check the assembly instructions to see that all parts have been assembled properly.
- D. During operation of equipment, one person should be in a position to monitor the entire operation.

NOTE

During the initial start-up and break-in period, the operator should note any unusual vibrations or noises and take the appropriate action.



Make certain everyone is clear before operating or moving the machine.

- E. The bin well inside the bin should have a control gate. The gate should be closed before start-up and closed before shutdown to allow the machine to clean out.
- F. The controls for the control gate should either pull or push open, depending on the type of well you have. Use the control gate to regulate a flow of less than full capacity until several hundred bushels of grain have been augured to polish the flighting assembly and tube.
- G. Any new screw conveyor or one that has set idle for a season should go through a “break-in” period. This “break-in” consists of running the auger at half capacity until the screw becomes polished and smooth before attempting to run at full capacity. It is recommended that several hundred bushels of grain be augured at partial capacity.

CAUTION

Failure of your auger is very likely to occur if it is run at full capacity before the screw has become polished.

CAUTION

NEVER operate augers empty for any length of time as excessive wear will result.

- H. Do not stop or start augers under load, especially before the flight and tube become well polished, as this may cause the auger to “lockup”.

CAUTION

Excessive wear will result if auger is run at speeds in excess of what is recommended.

- I. Do not run auger at too slow speed, this will cause the motor to over load and a higher torque will be required to turn the auger, which in turn may cause damage to the auger.

1. Normal Shutdown

- A. Make certain unloading tubes are empty before stopping the unit.
- B. Disconnect and lockout the power source before leaving the work area.

2. Emergency Shutdown

- A. Know how to shut down the auger in case of an emergency.

CAUTION

Never restart when under a full load. Starting unit under load may result in damage to the machine. Such damage is considered abuse of the equipment.

- B. Should an emergency shut down occur:
 - 1. Disconnect and lockout the power source.
 - 2. Close bin well control gates.
 - 3. Clear out as much grain from the intake areas as you can.
 - 4. Reconnect and unlock the power source.
 - 5. Gradually clear the auger until there is no grain or obstructions.

3. Lockout

- A. Always stop and disconnect the power source whenever the operator must leave the work area or for maintenance of the machinery.
- B. Make sure equipment is locked out and that the machinery cannot be started while the operator is not in the work area.

▲WARNING

Use the type of main power disconnect switch that is capable of being locked only in the off position.

3. Storage Preparation

- A. Close all wells to discharge tube.
- B. Be sure the unload tube is empty.
- C. Make sure power source is disconnected and locked out.
- D. Check to see that all fasteners are secure.

<i>Problem</i>	<i>Possible Cause</i>	<i>Solution</i>
1. The auger is vibrating.	A. Damage can occur to the auger flighting, causing noise. Damage usually is caused from foreign material being run through the auger.	A1. It may be necessary to remove the flighting for inspection.
	A. Drive belt may be overtightened, putting head stub and flight in a bind.	A1. Loosen the drive belts.
2. Capacity is too low.	A. There may not be enough grain reaching the auger.	A1. Make sure the intake has not bridged over, restricting flow. The flighting at the intake should be covered with grain for maximum capacity.
	B. The auger is moving too slowly.	B1. Check the auger speed. Low capacity will result from speeds slower than recommended.
3. The auger plugs.	A. The auger may be "jamming" because too much grain is reaching the auger.	A1. Use the control gates to decrease the amount of grain the auger is gathering.
	B. The grain may be wet.	B1. If wet grain or other hard-to-move material is being augered, use a larger size motor than recommended for normal use.
	C. The auger may be jammed with foreign material.	C1. Remove any foreign material in the auger.
	D. The motor may be too small or wired incorrectly.	D1. Check wiring or consider using the next larger size motor.

6" STANDARD DUTY PARTLIST

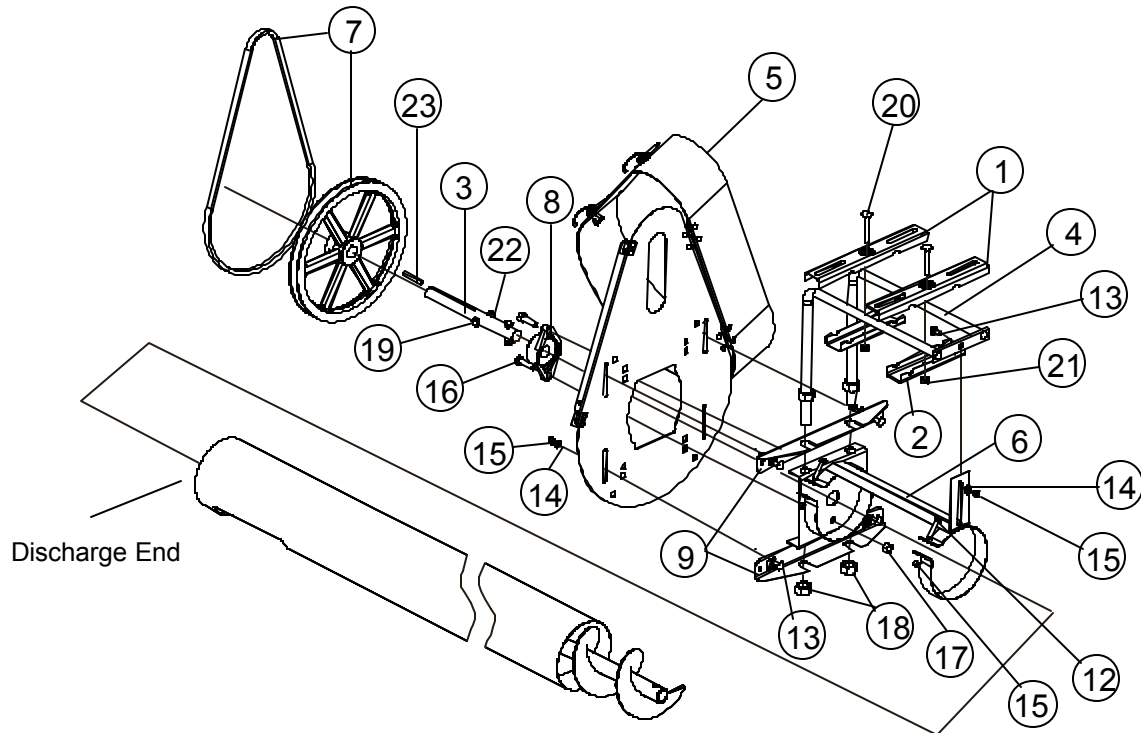

6" PARTSLIST

Ref. No.	Part No.	Description	Qty.
1	GK1063	Motor Mount Top Strap	2
2	GK1064	Motor Mount Bottom Strap	2
3	GK1117	Intake Shaft 1" O.D. x 7" Long	1
4	GK1312	Motor Mount Rod Assembly	1
5	GK1454	Belt Guard Assembly	1
6	GK1866	Head Plate Assembly	1
7	GK4594	Belt & Pulley Kit: 12" 1 Belt Pulley w/ 1" Bore (V B-46)	1
7	GK4595	Belt & Pulley Kit: 12" 2 Belt Pulley w/ 1" Bore (V B-46)	1
7	GK4596	Belt & Pulley Kit: 15" 2 Belt Pulley w/ 1" Bore (V B-62)	1
7	GK4597	Belt & Pulley Kit: 12" 3 Belt Pulley w/ 1" Bore (V B-46)	1
9	GK1311	Belt Guard Mounting Angle	2
7	GK4598	Belt & Pulley Kit: 15" 3 Belt Pulley w/ 1" Bore (V B-62)	1
12	S-2741	5/16" - 18 X 1-1/2" Zinc Grade 5 HHCS Bolt	2
13	S-6076	5/16" - 18 x 3/4" Zinc Grade 2 Carriage Bolt	5
14	S-1937	5/16" SAE Zinc Grade 2 Flat Washer	5
15	S-7382	5/16" - 18 Zinc Grade 5 Nylock Nut	7
16	S-3886	7/16" - 14 x 1 1/4" Zinc Grade 5 HHCS Bolt	2
17	S-8317	7/16" - 14 Zinc Grade C Stover Nut	2
18	S-234	3/4" - 10 Zinc Grade 5 Hex Nut	4
19	S-3727	3/8" - 16 x 1-3/4" Zinc Grade 8 HHCS Bolt	2
20	S-6995	3/8" - 16 x 2-1/2" Zinc Grade 5 Carriage Bolt	2
21	S-456	3/8" Zinc YDP Grade 5 Hex Nut	2
22	S-8251	3/8" - 16 Zinc Grade C Stover Nut	2
23	S-4513	1/4" x 1/4" x 2" Long Square Key	1

8" STANDARD DUTY PARTLIST

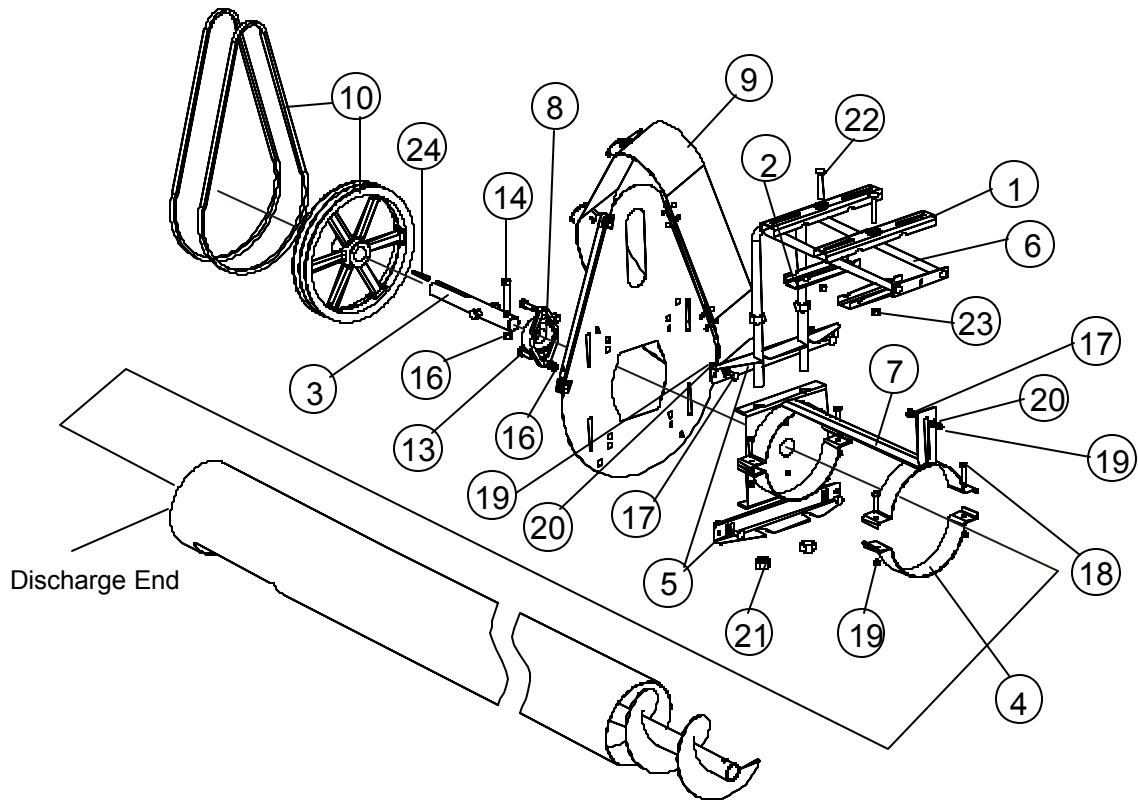

8" STANDARD DUTY PARTLIST

Ref. No.	Part No.	Description	Qty.
1	GK1063	Motor Mount Top Strap	2
2	GK1064	Motor Mount Bottom Strap	2
3	GK1884	Intake Shaft 1-1/4" O.D. x 9" Long	1
4	GK1055	8" x 2" 12 Gauge Galvanized Halfband	1
5	GK1311	Belt Guard Mounting Angle	2
6	GK1327	8" Motor Mount Weldment	1
7	GK1329	8" Head Plate Assembly	1
8	GK1330	2 Hole Flange Bearing 1-1/4" Bore w/ Lock Collar	1
9	GK1454	Belt Guard Assembly	1
10	GK4891	Belt & Pulley Kit: 12" 2 Belt Pulley w/ 1-1/4" Bore (V B-48)	1
10	GK4789	Belt & Pulley Kit: 15" 2 Belt Pulley w/ 1-1/4" Bore (V B-57)	1
10	GK4670	Belt & Pulley Kit: 15" 3 Belt Pulley w/ 1-1/4" Bore (V B-57)	2
13	S-3886	7/16" - 14 x 1-1/4" Zinc Grade 5 HHCS Bolt	2
14	S-7372	7/16" - 14 x 2-1/2" Zinc Grade 8 HHCS Bolt	2
16	S-8317	7/16" - 14 Zinc Grade C Stover Nut	4
17	S-6076	5/16" - 18 x 3/4" Zinc Grade 2 Carriage Bolt	5
18	S-2741	5/16" - 18 x 1-1/2" Zinc Grade 5 HHCS Bolt	4
19	S-7382	5/16" - 18 Zinc Grade 5 Nylock Nut	5
20	S-1937	5/16" SAE Zinc Grade 2 Flat Washer	5
21	S-234	3/4" - 10 Zinc Grade 5 Hex Nut	4
22	S-6995	3/8" - 16 x 2-1/2" Zinc Grade 5 Carriage Bolt	2
23	S-456	3/8" Zinc YDP Grade 5 Hex Nut	2
24	S-4513	1/4" x 1/4" x 2" Long Square Key	1

8" HEAVY DUTY PARTLIST

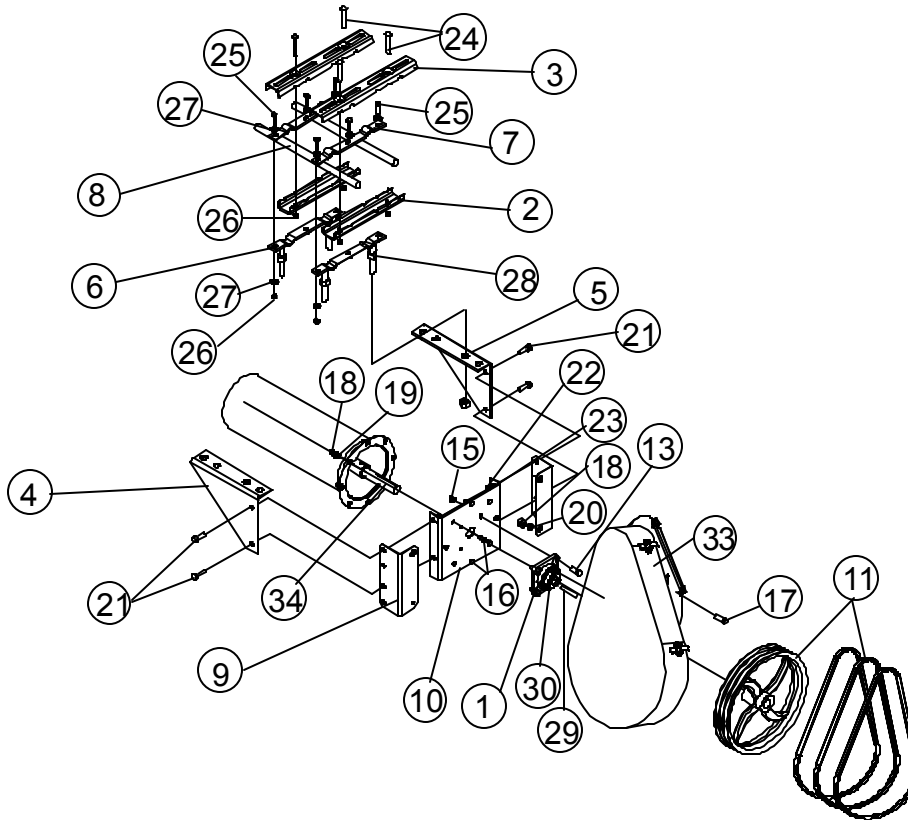

8" HEAVY DUTY PARTLIST

Ref. No.	Part No.	Description	Qty.
1	GK1017	4 Hole Flange Bearing with 1-1/4" Bore and Lock Collar	1
2	GK1341	Motor Mount Bottom Clip	2
3	GK1342	Motor Mount Top Clip	2
4	GK1897	Left Side Motor Mount	1
5	GK1898	Right Side Motor Mount	1
6	GK2108	8" Strap & Rod Assembly	2
7	GK2109	8" Top Strap	2
8	GK2110	Motor Mount Rods 1"O.D. x 19" Long	2
9	GK3096	Belt Guard Mounting Angle	2
10	GK3097	8" Head Plate	1
11	GK4790	Belt & Pulley Kit: 18.4" 2 Belt Pulley w/ 1-1/4" Bore (V B-57)	1
11	GK4791	Belt & Pulley Kit: 18.4" 3 Belt Pulley w/ 1-1/4" Bore (V B-57)	1
13	S-3886	7/16" - 14 x 1-1/4" Zinc Grade 5 HHCS Bolt	4
14	S-7013	7/16" - 14 x 2-1/2" Zinc Grade 5 HHCS Bolt	2
15	S-8317	7/16" - 14 Zinc Grade C Stover Nut	4
16	S-1196	5/16" - 18 x 1" Zinc Grade 5 HHCS Bolt	8
17	S-6076	5/16" - 18 x 3/4" Zinc Grade 2 Carriage Bolt	4
18	S-396	5/16" - 18 Zinc YDP Grade 2 Hex Nut	12
19	S-1147	5/16" Medium Zinc Split Lock Washer	8
20	S-845	5/16" USS Zinc Flat Washer	4
21	S-7935	1/2" - 13 x 1" Zinc Grade 5 HHCS Bolt	4
22	S-3729	1/2" - 13 Zinc YDP Grade 5 Hex Nut	4
23	S-236	1/2" Medium Zinc Split Lock Washer	4
24	S-8055	3/8" - 16 X 3" Zinc Carriage Bolt	4
25	S-2086	3/8" - 16 X 1-1/2" Zinc Grade 8 HHCS Bolt	6
26	S-456	3/8" Zinc YDP Grade 5 Hex Nut	10
27	S-248	3/8" USS Zinc Grade 2 Flat Washer	12
28	S-234	3/4" - 10 Zinc Grade 5 Hex Nut	8
29	S-4513	1/4" x 1/4" x 2" Long Square Key	2
30	S-7153	Lock Collar with 1" I.D.	2
31	S-8276	1/4" x 1/4" x 3" Long Square Key	2
32	GK4235	Hardware Package for Mounting Bracket	1
33	GK1454	Belt Guard Assembly	1
34	GK1331	Head Drive Shaft	1

10" STANDARD DUTY PARTLIST

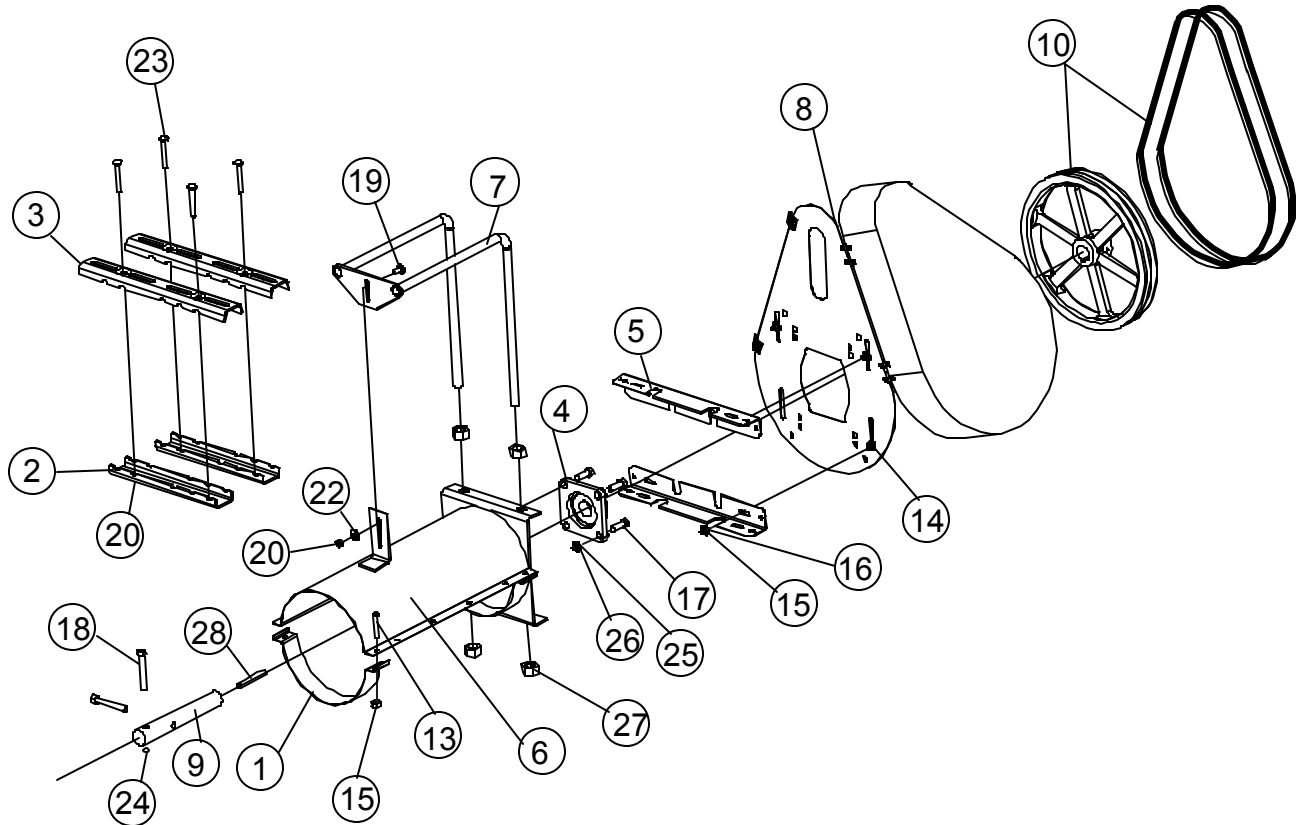

10" STANDARD DUTY PARTLIST			
Ref. No.	Part No.	Description	Qty.
1	GK1057	10" x 2" 12 Gauge Galvanized Halfband	1
2	GK1341	Motor Mount Bottom Clip	2
3	GK1342	Motor Mount Top Clip	2
4	GK1343	Flange Bearing with 1-1/2" Bore and Lock Collar	1
5	GK1344	Belt Guard Mounting Angle	2
6	GK1349	10" Head Plate Assembly	1
7	GK1350	10 " Motor Mount Weldment	1
8	GK1454	Belt Guard Assembly	1
9	GK2907	Intake Shaft 1-1/2" x 9-1/2"	1
10	GK4800	Belt & Pulley Kit: 15" 2 Belt Pulley w/ 1-1/2" Bore (V B-57)	1
10	GK4802	Belt & Pulley Kit: 15" 3 Belt Pulley w/ 1-1/2" Bore (V B-57)	1
10	GK4804	Belt & Pulley Kit: 15" 4 Belt Pulley w/ 1-1/2" Bore (V B-57)	1
13	S-2741	5/16" - 18 x 1-1/2" Zinc Grade 5 HHCS Bolt	4
14	S-6076	5/16" - 18 x 3/4" Zinc Grade 2 Carriage Bolt	4
15	S-7382	5/16" - 18 Zinc Grade 5 Nylock Nut	8
16	S-1937	5/16" SAE Zinc Grade 2 Flat Washer	4
17	S-7528	1/2" - 13 x 1-1/2" Zinc Grade 2 HHCS Bolt	4
18	S-8252	1/2" - 13 x 3" Zinc Grade 8 HHCS Bolt	2
19	S-3585	3/8" - 16 x 1" Zinc Grade 5 Carriage Bolt	1
20	S-456	3/8" Zinc YDP Grade 5 Hex Nut	4
21	S-7383	3/8" - 16 Zinc Nylock Nut	1
22	S-7523	3/8" USS Zinc Grade 2 Flat Washer	1
23	S-8055	3/8" - 16 x 3" Zinc Carriage Bolt	4
24	S-8315	1/2" - 13 Zinc Grade C Stover Nut	4
25	S-236	1/2" Medium Zinc Split Lock Washer	4
26	S-7510	1/2" - 13 Zinc Grade 2 Hex Nut	4
27	S-3214	7/8" - 9 Zinc Grade 2 Hex Nut	4
28	GC04494	3/8" x 3" Square Key	1

10" HEAVY DUTY PARTLIST

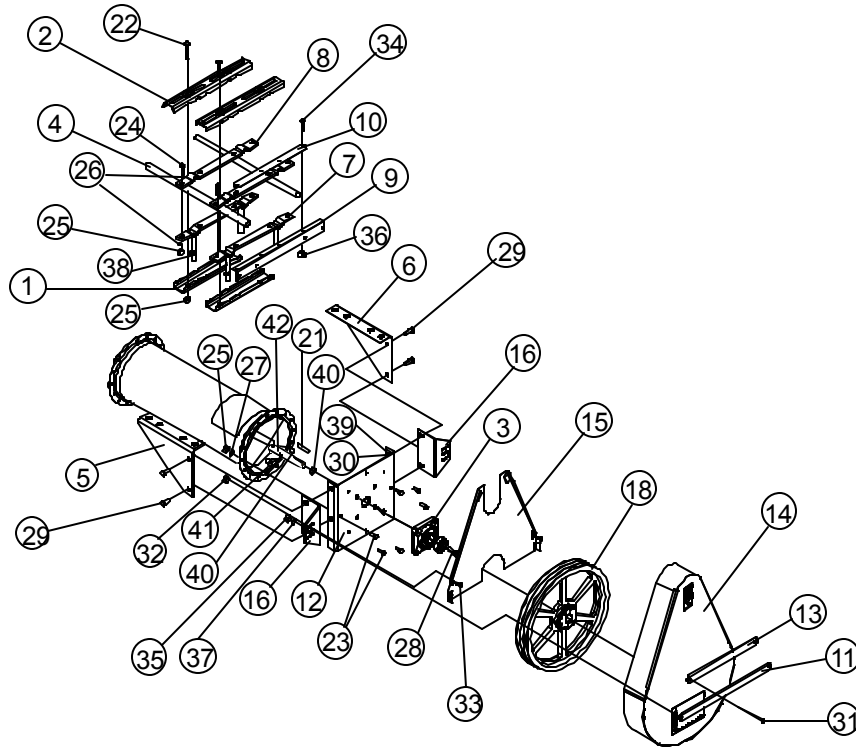

10" HEAVY DUTY PARTLIST			
Ref. No.	Part No.	Description	Qty.
1	GK1341	Motor Mount Bottom Clip	2
2	GK1342	Motor MountTop Clip	2
3	GK1343	Flange Bearing with 1-1/2" Bore and Lock Collar	1
4	GK1893	1" O.D. x 23" Long Motor Mount Rod	2
5	GK1897	Left Side Motor Mount	1
6	GK1898	Right Side Motor Mount	1
7	GK1900	Strap and Rod Assembly	2
8	GK1901	Top Strap	2
9	GK2017	Belt Guard Mounting Angle - 16"	1
10	GK2018	Clamp Bar for Belt Guard Mounting Angle	1
11	GK2019	Clamp Bar for Belt Guard - 16"	1
12	GK2561	Head Plate	1
13	GK2564	Clamp Bar for Belt Guard	1
14	GK2565	Front Belt Guard Weldment	1
15	GK2568	Back Belt Guard Weldment	1
16	GK2569	Belt Guard Support	2
17	GK4235	Hardware for Mounting Bracket	1
18	GK4801	Belt & Pulley Kit: 18.4" 2 Belt Pulley with 1-1/2" Bore (V B-71)	1
18	GK4803	Belt & Pulley Kit: 18.4" 3 Belt Pulley with 1-1/2" Bore (V B-71)	1
21	GC04494	3/8" x 3" Square Key	1
22	S-8055	3/8" - 16 x 3" Zinc Carriage Bolt	4
23	S-7469	3/8" -16 x 1" Zinc Grade 5 HHCS Bolt	8
24	S-2086	3/8" - 16 x 1-1/2" Zinc Grade 8 HHCS Bolt	8
25	S-456	3/8" Zinc YDP Grade 5 Hex Nut	20
26	S-248	3/8" USS Zinc Grade 2 Flat Washer	16
27	S-1054	3/8" Medium Zinc Split Lock Washer	8
28	S-3728	1/2" - 13 x 1-1/2" Zinc Grade 8 HHCS Bolt	4
29	S-7534	1/2" - 13 x 1-1/4" Zinc HHCS Bolt	4
30	S-7510	1/2" - 13 Zinc Grade2 Hex Nut	4
31	S-7116	1/4" - 20 x 5-1/2" Zinc Grade 2 HHCS Bolt	2
32	S-1102	1/4" - 20 Zinc Grade 2 Hex Nut	4
33	S-6076	5/16" - 18 x 3/4" Zinc Grade 2 Carriage Bolt	2
34	S-7149	5/16" - 18 x 1-3/4" Zinc Grade 5 HHCS Bolt	4
35	S-7382	5/16" - 18 x Zinc Grade 5 Nylock Nut	2
36	S-396	5/16" - 18 Zinc YDP Grade 2 Hex Nut	4
37	S-1937	5/16" SAE Zinc Grade 2 Flat Washer	4
38	S-234	3/4" - 10 Zinc Grade 5 Hex Nut	8
39	S-236	1/2" Medium Zinc Split Lock Washer	4
40	S-8260	1/2" -13 Zinc Grade 5 Nylock Nut	6
41	S-3231	1/2" - 13 x 3-1/2" Zinc Grade 5 HHCS Bolt	2
42	GK1289	1-1/2" O.D. x 11-1/2" Drive Shaft	1

12" HEAVY DUTY PARTLIST

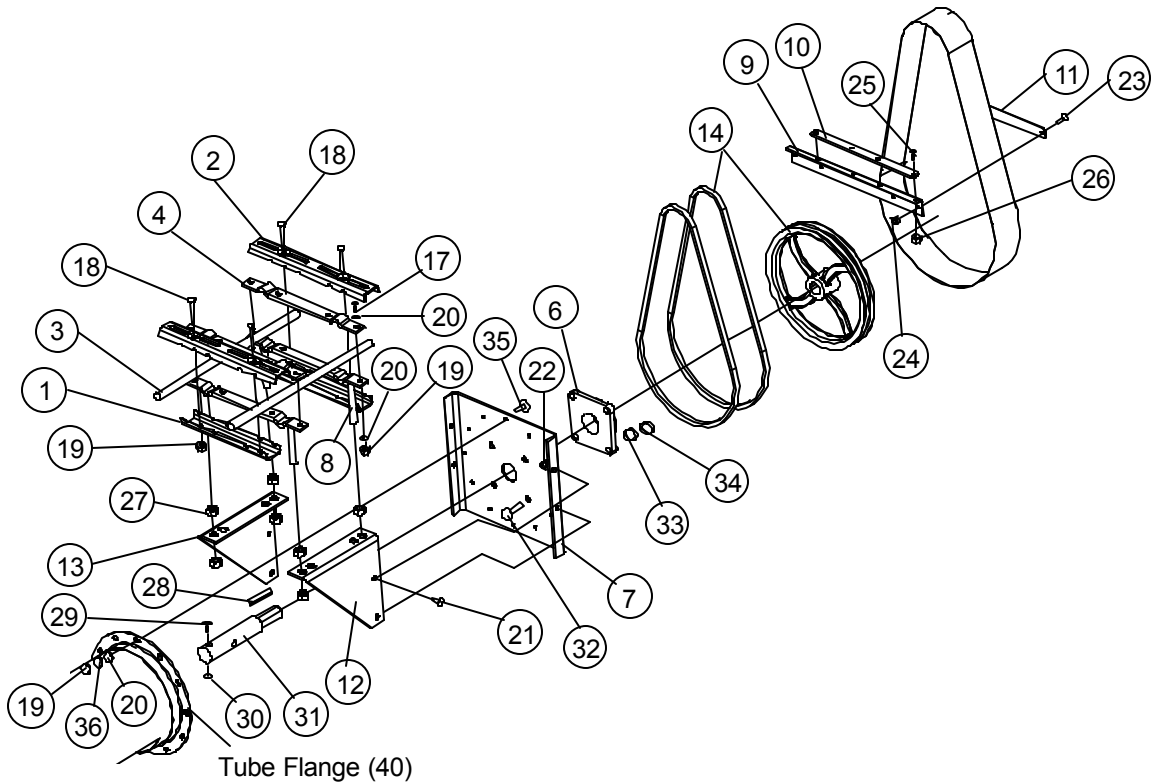

12" HEAVY DUTY PARTLIST

Ref. No.	Part No.	Description	Qty.
1	GK1341	Motor Mount Bottom Clip	2
2	GK1342	Motor Mount Top Clip	2
3	GK1893	1" O.D. x 23" Long Motor Mount Rod	2
4	GK1901	Top Strap	2
5	GK1998	Belt Guard Weldment	1
6	GK2004	Bearing with Housing and Lock Collar 2" Bore	1
7	GK2005	12" Head Plate Assembly	1
8	GK2015	Strap and Rod Assembly	2
9	GK2017	20" Mounting Angel for Belt Guard	1
10	GK2018	Clamp Bar for Mounting Angle	1
11	GK2019	Clamp Bar for Belt Guard - 16"	1
12	GK2173	12" Commercial Left Side Plate	1
13	GK2174	12" Commercial Right Side Plate	1
14	GK5060	Belt & Pulley Kit: 18.4" 2 Belt Pulley with 1-1/2" Bore (V B-71)	1
14	GK5061	Belt & Pulley Kit: 18.4" 3 Belt Pulley with 1-1/2" Bore (V B-71)	1
14	GK5062	Belt & Pulley Kit: 15" 4 Belt Pulley with 1-1/2" Bore (V B-57)	1
17	S-7515	3/8" - 16 x 1-1/2" Zinc Grade 5 HHCS Bolt	8
18	S-8055	3/8" - 16 x 3" Zinc Carriage Bolt	4
19	S-456	3/8" Zinc YDP Grade 5 Hex Nut	12
20	S-248	3/8" USS Zinc Grade 2 Flat Washer	16
21	S-7935	1/2" - 13 x 1" Zinc Grade 5 HHCS Bolt	4
22	S-7510	1/2" - 13 Zinc Grade 2 Hex Nut	4
23	S-7111	1/4" - 20 x 5" Zinc Grade 5 HHCS Bolt	2
24	S-1102	1/4" - 20 Zinc Grade 2 Hex Nut	2
25	S-7149	5/16" - 18 x 1-3/4" Zinc Grade 5 HHCS Bolt	4
26	S-396	5/16" - 18 Zinc YDP Grade 2 Hex Nut	4
27	S-234	3/4" - 10 Zinc Grade 5 Hex Nut	8
28	GK3865	3/8" x 2" Long Square Key	1
29	S-8345	5/8" - 11 x 4" HHCS Grade 5	2
30	S-6494	5/8" - 11 Zinc Grade 5 Deformed Locknut	2
31	GK2006	2" to 1-1/2" x 12" Drive Shaft Stub	1
32	S-8399	5/8"-11 X 2" Aluminum Grade 5 HHCS Bolt	4
33	S-3208	5/8" Lock Washer	4
34	S-4110	5/8"-11 Zinc Grade 5 Hex Nut	4
35	S-7469	3/8" - 16 x 1" Zinc Grade 5 HHCS Bolt	12
36	S-7524	3/8" Lock Washer	12

THE COMPANY WARRANTS ALL PRODUCTS MANUFACTURED TO BE FREE OF DEFECTS IN MATERIAL AND WORKMANSHIP UNDER NORMAL USAGE AND CONDITIONS FOR A PERIOD OF TWELVE (12) MONTHS AFTER RETAIL SALE TO THE ORIGINAL END USER OF SUCH PRODUCTS. OUR ONLY OBLIGATION IS, AND PURCHASER'S SOLE REMEDY SHALL BE TO REPAIR OR REPLACE, AT THE COMPANY'S OPTION AND EXPENSE, PRODUCTS THAT, IN THE MANUFACTURERS SOLE JUDGEMENT, CONTAIN A MATERIAL DEFECT DUE TO MATERIALS OR WORKMANSHIP. ALL DELIVERY AND SHIPMENT CHARGES TO AND FROM THE FACTORY WILL BE PURCHASER'S RESPONSIBILITY. EXPENSES INCURRED BY OR ON BEHALF OF THE PURCHASER WITHOUT PRIOR WRITTEN AUTHORIZATION FROM AN AUTHORIZED EMPLOYEE OF THE COMPANY SHALL BE THE SOLE RESPONSIBILITY OF THE PURCHASER.

EXCEPT FOR THE ABOVE EXPRESS LIMITED WARRANTIES, THE COMPANY MAKES NO WARRANTY OF ANY KIND, EXPRESSED OR IMPLIED, INCLUDING, WITHOUT LIMITATION, WARRANTIES OF MERCHANTABILITY OR FITNESS FOR A PARTICULAR PURPOSE OR USE IN CONNECTION WITH (i) PRODUCT MANUFACTURED OR SOLD BY THE COMPANY OR (ii) ANY ADVICE, INSTRUCTION, RECOMMENDATION OR SUGGESTION PROVIDED BY AN AGENT, REPRESENTATIVE OR EMPLOYEE OF THE COMPANY REGARDING OR RELATED TO THE CONFIGURATION, INSTALLATION, LAYOUT, SUITABILITY FOR A PARTICULAR PURPOSE, OR DESIGN OF SUCH PRODUCT OR PRODUCTS.

IN NO EVENT SHALL THE COMPANY BE LIABLE FOR ANY DIRECT, INDIRECT, INCIDENTAL, OR CONSEQUENTIAL DAMAGES, INCLUDING, WITHOUT LIMITATION, LOSS OF ANTICIPATED PROFITS OR BENEFITS. PURCHASER'S SOLE AND EXCLUSIVE REMEDY SHALL BE LIMITED TO THAT STATED ABOVE, WHICH SHALL NOT EXCEED THE AMOUNT PAID FOR THE PRODUCT PURCHASED. THIS WARRANTY IS NOT TRANSFERABLE AND APPLIES ONLY TO THE ORIGINAL PURCHASER. WE SHALL HAVE NO OBLIGATION OR RESPONSIBILITY FOR ANY REPRESENTATIVE OR WARRANTIES MADE BY OR ON BEHALF OF ANY DEALER, AGENT OR DISTRIBUTOR OF THE COMPANY.

THE COMPANY ASSUMES NO RESPONSIBILITY FOR FIELD MODIFICATIONS. MODIFICATIONS TO THE PRODUCT NOT SPECIFICALLY COVERED BY THE CONTENTS OF THIS MANUAL WILL NULLIFY ANY PRODUCT WARRANTY THAT MIGHT HAVE BEEN OTHERWISE AVAILABLE. THE USE OF OUR EQUIPMENT TO HANDLE MATERIALS OTHER THAN FREE FLOWING, NONABRASIVE AND DRY MATERIALS, AS INTENDED, WILL RESULT IN THE VOIDING OF THIS LIMITED WARRANTY.

THE FOREGOING WARRANTY SHALL NOT COVER PRODUCTS OR PARTS WHICH HAVE BEEN DAMAGED BY NEGLIGENT USE, MISUSE, ALTERATION, OR ACCIDENT. ANY NEGLIGENT USE, MISUSE, ALTERATION, OR DAMAGE DUE TO ACCIDENT, AS DETERMINED BY A COMPANY REPRESENTATIVE, MAY VOID THE WARRANTY. THIS WARRANTY COVERS ONLY PRODUCTS MANUFACTURED BY THE COMPANY. THIS WARRANTY IS EXCLUSIVE AND IN LIEU OF ALL OTHER WARRANTIES EXPRESS OR IMPLIED. WE RESERVES THE RIGHT TO MAKE DESIGN OR SPECIFICATION CHANGES AT ANY TIME, BEARING NO RESPONSIBILITY TO MAKE SIMILAR DESIGN OR SPECIFICATION CHANGES ON PREVIOUSLY SOLD MERCHANDISE.

PRIOR TO INSTALLATION, PURCHASER HAS THE RESPONSIBILITY TO RESEARCH AND COMPLY WITH ALL FEDERAL, STATE, AND LOCAL CODES WHICH MAY APPLY TO THE LOCATION AND INSTALLATION.

This Equipment shall be installed in accordance with the current installation codes and applicable regulations which should be carefully followed in all cases. Authorities having jurisdiction should be consulted before installation occurs.

== GRAIN KING ==

**1004 East Illinois Street
Assumption, IL 62510
217-226-4421 Phone**
