

12" and 16" Series II Sweep Quick Disconnect Control Box Kit

Owner's Manual

PNEG-1366

Date: 10-11-10

GSI GROUP



PNEG-1366

Model Number :

Date Delivered:

Date Installed:

Notes:

Personnel operating or working around this equipment should read this manual. This manual must be delivered with equipment to its owner. Failure to read this manual and its safety instructions is a misuse of the equipment. Any misuse of the equipment may void the warranty.

Contents

Chapter 1 Product Overview	5
Chapter 2 Safety	6
Safety Guidelines	6
Safety Instructions	7
Operator Qualifications	11
Chapter 3 Decals	12
Chapter 4 Introduction	15
General Information	15
Capacities and Specifications	16
Chapter 5 Assembly	18
Docking Station Mount	18
Control Panel Conduit Hole (Pre-June 2010)	19
Control Panel Installation	20
Control Panel Receptacle Mounting (Current Style Panel)	20
Control Panel and Receptacle Installation	20
Guidance Handle Installation	22
Place Control Panel Into Docking Station	24
Control Panel Setup	25
Calibration	30
Operation	31
Chapter 6 Start-Up	32
Perform Pre-Start Checks	32
Start the Auger	33
Chapter 7 Operation	34
Operating the Sweep Auger	34
Operating the Sweep Auger Control Panel	35
Chapter 8 Shut Down	36
Normal Shut Down	36
Emergency Shut Down	36
Storage Preparation	36
Chapter 9 Maintenance	37
Maintain the Auger	37
Chapter 10 Control Panel Diagrams	38
Series II Sweep Control Package - 08-32A:3-12A, Non-575V (S2PFA)	38
Series II Sweep Control Package - 30-40A:3-12A, Non-575V (S2PFB)	39
Series II Sweep Control Package - 08-32A:3-12A, 575V Only (S2PFC)	40
Control Panel Schematic (460/3/60) Pre-June 2010	41
Control Panel Schematic (230/3/60) Pre-June 2010	42
Control Panel Schematic (380/3/50) Pre-June 2010	43
Chapter 11 Troubleshooting	44

Table of Contents

Chapter 12 Parts List	45
Control Panel Components Pre-June 2010 Style Panel	46
Quick Detach Control Panel Assembly (GC10115) Pre-June 2010	48
Control Box Base Assembly (GC10109) (for Quick Detach Control Panel) Pre-June 2010	49
Dock Station Assembly (GC10116) (for Quick Detach Control Panel) Pre-June 2010	50
Conduit Assembly (GC10113) (for Quick Detach Control Panel)	51
Drop Cord Assembly (GC10079) (for Quick Detach Control Panel) Pre-June 2010	52
Quick Detach Control Panel Receptacles Parts	53
Quick Detach Control Panel Package (GK80112)	54
Lift Base Panel Assembly (GK80108)	55
Lift Base Dock Assembly (GK80110)	56
Drop Cord Assembly (GK80111)	57
Chapter 13 Warranty	59

1. Product Overview

The Quick Disconnect Control Box was designed to work 12" and 16" GSI Series II Sweeps. This Quick Disconnect Control Box modular design will allow you to move the control box to each sweep location, therefore only one control box is needed to control all of the same size sweeps. Each sweep location will require a docking station for the control box base to slide into. The control box base is supplied with four (4) handles for manual lifting. These handles can be installed in any of the holes located on the outside edges of the base back plate. The base back plate also has two (2) chain lift holes for mechanical hoisting.



Never attempt to lift the control box by yourself. Always use two (2) or more persons with proper lifting equipment.

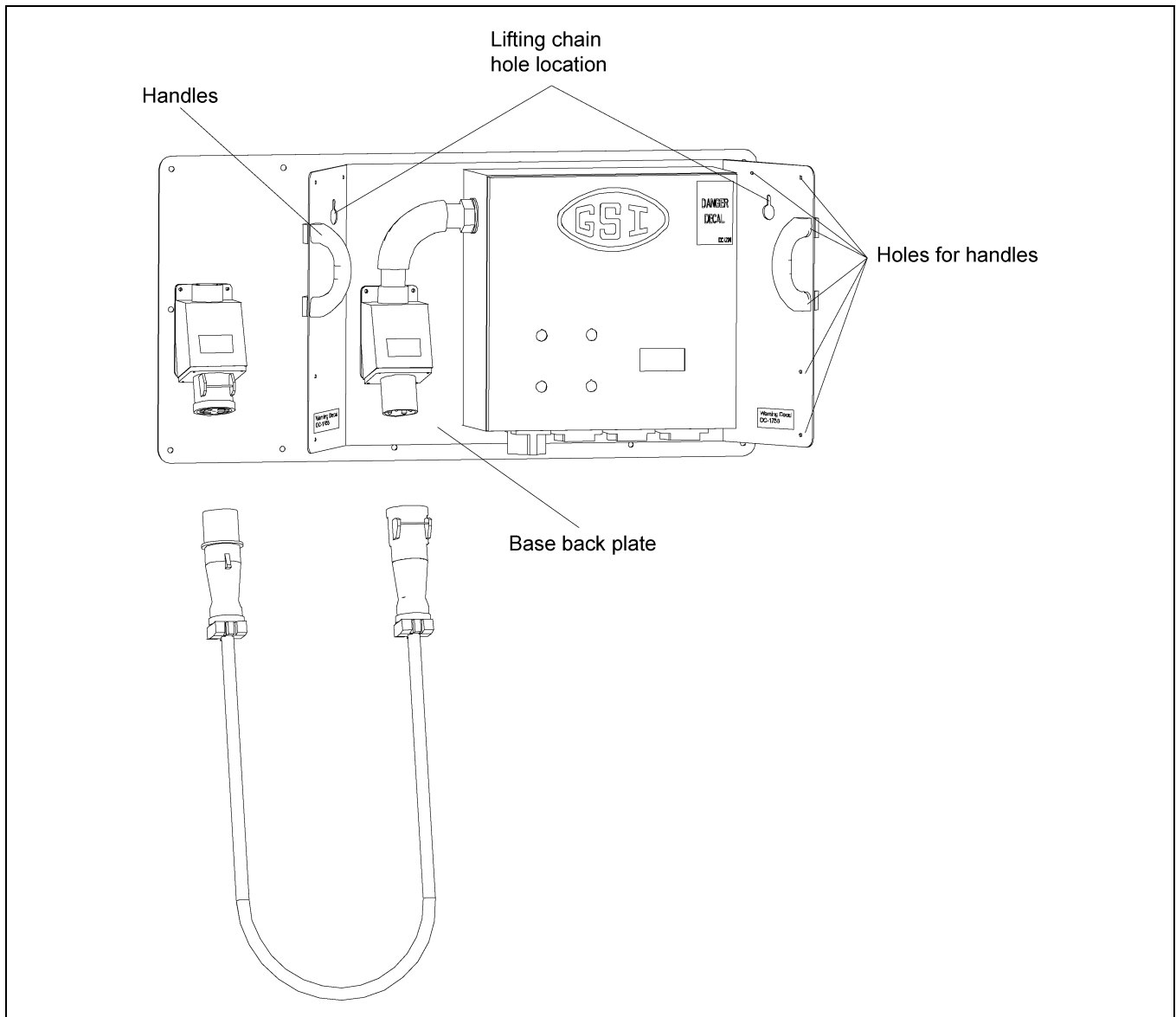

Figure 1A

Safety Guidelines

This manual contains information that is important for you, the owner/operator, to know and understand. This information relates to protecting **personal safety** and **preventing equipment problems**. It is the responsibility of the owner/operator to inform anyone operating or working in the area of this equipment of these safety guidelines. To help you recognize this information, we use the symbols that are defined below. Please read the manual and pay attention to these sections. Failure to read this manual and its safety instructions is a misuse of the equipment and may lead to serious injury or death.



This is the safety alert symbol. It is used to alert you to potential personal injury hazards. Obey all safety messages that follow this symbol to avoid possible injury or death.



DANGER indicates an imminently hazardous situation which, if not avoided, will result in death or serious injury.



WARNING indicates a potentially hazardous situation which, if not avoided, could result in death or serious injury.



CAUTION indicates a potentially hazardous situation which, if not avoided, may result in minor or moderate injury.



CAUTION used without the safety alert symbol indicates a potentially hazardous situation which, if not avoided, may result in property damage.



NOTE indicates information about the equipment that you should pay special attention.

Safety Instructions

Our foremost concern is your safety and the safety of others associated with this equipment. We want to keep you as a customer. This manual is to help you understand safe operating procedures and some problems which may be encountered by the operator and other personnel.

As owner and/or operator, it is your responsibility to know what requirements, hazards and precautions exist, and to inform all personnel associated with the equipment or in the area. Safety precautions may be required from the personnel. Avoid any alterations to the equipment. Such alterations may produce a very dangerous situation where **SERIOUS INJURY** or **DEATH** may occur.

This equipment shall be installed in accordance with the current installation codes and applicable regulations which should be carefully followed in all cases. Authorities having jurisdiction should be consulted before installations are made.

Follow Safety Instructions

Carefully read all safety messages in this manual and safety signs on your equipment. Keep signs in good condition. Replace missing or damaged safety signs. Be sure new equipment components and repair parts include the current safety signs. Replacement safety signs are available from the manufacturer.

Learn how to operate the machine and how to use controls properly. Do not let anyone operate without instruction. Keep unqualified personnel out of the work area at ALL times.

Keep your machinery in proper working condition. Unauthorized modifications to the machine may impair the function and/or safety and affect machine life.

Never work alone.

Never start equipment until all personnel are clear of the work area.

Never attempt to assist machinery or try to remove trash from equipment while in operation.

Keep all guards in place during operation.

Always lock out power to equipment when work is finished.

If you do not understand any part of this manual and need assistance, contact your dealer.



Read ALL Safety Information and Instructions before Operating Machinery.

2. Safety

Lifting Hazard

Do not lift equipment without personal or mechanical assistance. Single person lift could cause injury.

To avoid muscle strain or back injury, use lifting aids and proper lifting techniques when removing or replacing the control box.

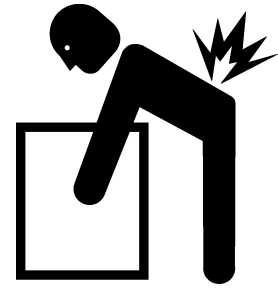

Use Proper Lifting Equipment

Install and Operate Equipment Properly

This equipment shall be installed in accordance with the current installation codes and applicable regulations which should be carefully followed in all cases. Authorities having jurisdiction should be consulted before installations are made.

Electrical controls should be installed by a qualified electrician and must meet standards set by the national electrical code and all local and state codes.

A main power disconnect switch capable of being locked only in the OFF position should be used. The Disconnect must be LOCKED in the OFF position before unplugging either end of the power cord.



Electric Shock Hazard

Practice Safe Maintenance

ALWAYS turn off and lock out all power sources before performing any maintenance.

Lock Out Power



Understand service procedures before doing work. Keep area clean and dry.

Keep Work Area Clean



Never lubricate, service, or adjust machine while it is in operation. Keep hands, feet, and clothing from rotating parts. Replace all guards.

Replace Guards



Keep all parts in good condition and properly installed. Fix damage immediately. Replace worn or broken parts. Remove any build up grease, oil, or debris.

Prepare for Emergencies

Be prepared if fire starts.

Keep a first aid kit and fire extinguisher handy.

Keep emergency numbers for doctors, ambulance service, hospital and fire department near your telephone.

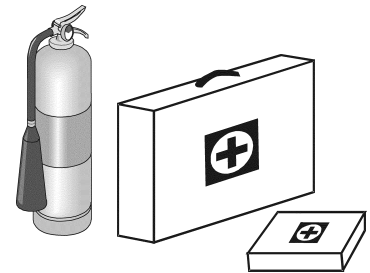

Keep Emergency Equipment Quickly Accessible

2. Safety

Wear Protective Clothing

Wear close fitting clothing and safety equipment appropriate to the job.

Remove all jewelry.

Long hair should be tied up and back.

Safety glasses should be worn at all times to protect eyes from debris.

Wear gloves to protect your hands from sharp edges on plastic or steel parts.

Wear steel toe boots to help protect your feet from falling debris. Tuck in any loose or dangling shoe strings.

A respirator may be needed to prevent breathing potentially toxic fumes and dust.

Wear hard hat to help protect your head.

Wear appropriate fall protection equipment when working at elevations greater than six feet (6').

Eye Protection

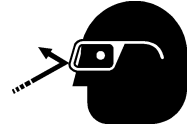

Gloves



Steel Toe Boots



Respirator



Hard Hat



Fall Protection



3. Decals

Figure 3A shows the location of the decals and safety signs which should appear on the Control Panel and Quick Disconnect Control Kit.

NOTE: Please remember safety signs provide important safety information for people working near bin unloading equipment that is in operation. Any safety signs that are worn, missing, illegible or painted over should be replaced immediately. Obtain FREE replacements by contacting GSI.

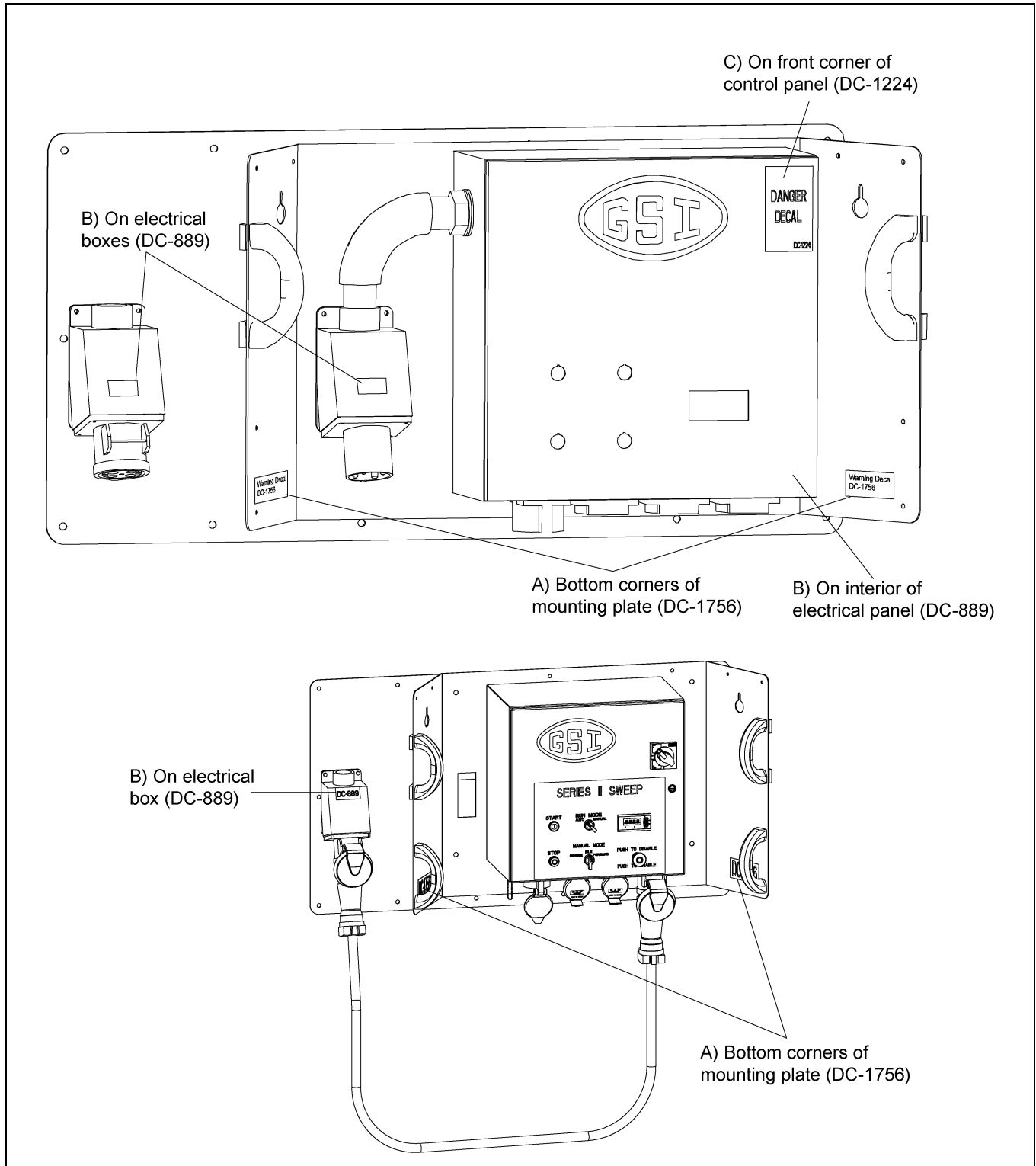

Figure 3A Control Panel Located Outside of Bin



DC-1756

DC-1756

A) DC-1756

Location: Corners of mounting plate.
 Size: 4-3/4" x 2-1/4"



DC-1224

DC-1224

C) DC-1224

Location: Corner of control panel.
 Size: 2-7/8" x 5"



DC-889

DC-889

B) DC-889

Location: Interior of control panel. On electrical boxes.
 Size: 2-13/16" x 1-7/16"

3. Decals

- A. DANGER Sign No. DC-1395 was supplied with your bin unloading equipment. This safety sign should be applied to the side of the bin near the bin opening, so it will be viewed by people entering into the bin storage building. Do not cover any safety signs or any other signs that are already there.
- B. If the safety sign location suggested is not in full view because of equipment modifications, other equipment in the area or any reason, then locate the safety sign in a more suitable location.
- C. Be certain the surface is clean, dry and free of dirt and oil. Peel paper backing from decals and stick into place. The adhesive backing will bond on contact.

NOTE: *Please remember, safety signs provide important safety information for people working near bin unloading equipment that is in operation.*

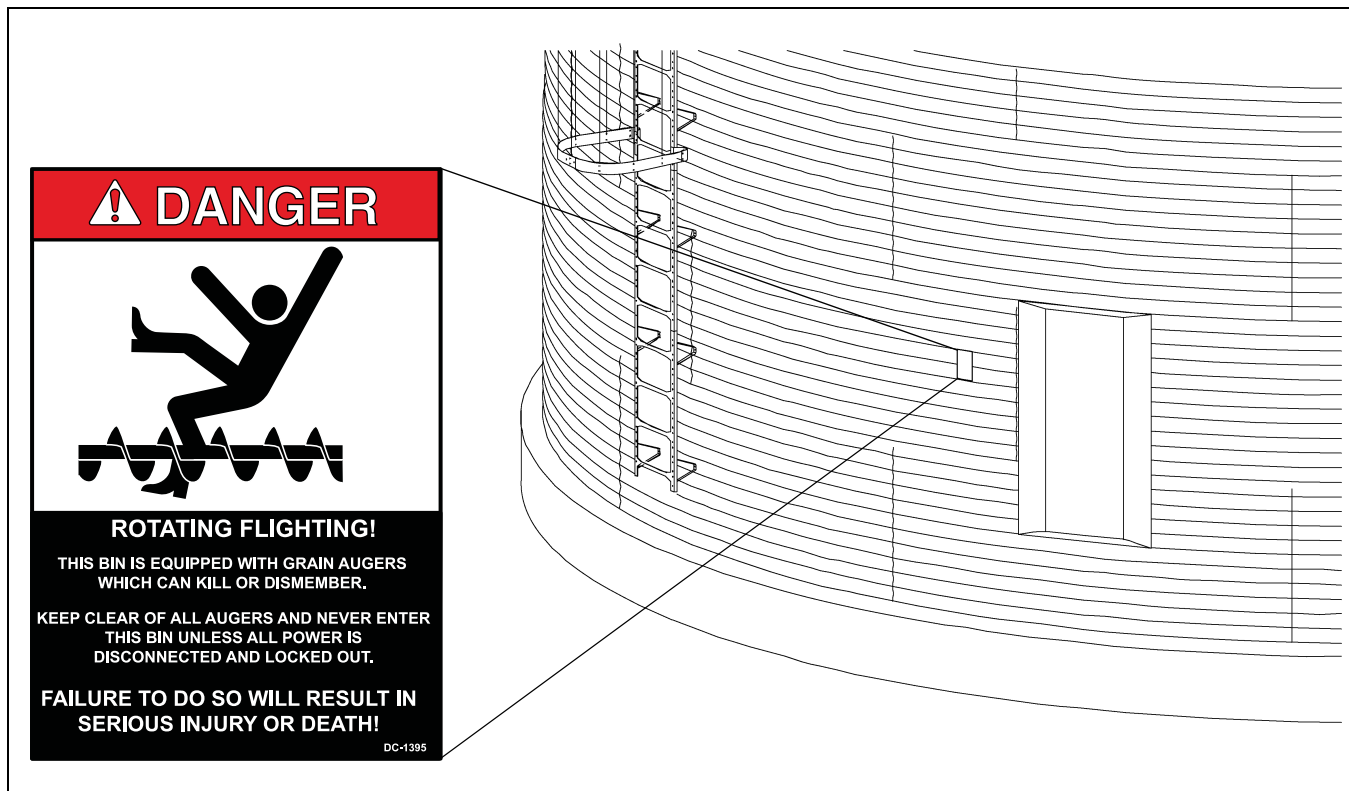

NOTE: *If the Safety Sign cannot be easily read for any reason or has been painted over, replace it immediately. Additional Safety Signs may be obtained free of charge from your dealer, distributor or ordered from the factory.*

Order SAFETY SIGN NO. DC-1395



NEVER enter a grain bin unless ALL power driven equipment has been shut down. Disconnect and lock out power before entering the bin or servicing the equipment.

General Information

1. GSI reserves the right to improve its product whenever possible and practical to do so. We reserve the right to change, improve and modify products at any time without obligation to make changes, improvements and modifications on equipment sold previously.
2. This bin sweep auger has been engineered and manufactured to give years of dependable service. The care and maintenance of this equipment will affect the satisfaction and service obtained. By following the instructions and suggestions recommended, the owner should receive quality service for many years. If additional information or assistance should be required, please contact GSI.
3. It is important to check both the quantity of parts and their descriptions with the packing list enclosed within each package. All claims for freight damage or shortage must be made by the consignee within ten (10) days from the date of the occurrence of freight damage. The consignee should accept the shipment after noting the damage or loss.

4. Introduction

Capacities and Specifications



Electrical controls and wiring should be installed by a qualified electrician. The motor disconnect switches and conductor cables should comply with the National Electrical code and any local codes which apply. Reset and motor starting stations should be located so the operator can see that all personnel are clear of the equipment.

1. Use the [Chart below](#) to determine the horsepower required.

Bin Diameter	12" Series II Sweep					16" Series II Sweep				
	Drive HP	Bushel/MT per Hour Horsepower			Length Pivot to End	Drive HP	Bushel/MT per Hour Horsepower			Length Pivot to End
		5000/125	6000/155	7000/180			8000/205	9000/230	10000/255	
36'	2	7.5	7.5	7.5	16.79' (5.12 m)	2	7.5	7.5	7.5	16.85' (5.14 m)
37'	2	7.5	7.5	7.5	17.79' (5.43 m)	2	7.5	7.5	7.5	16.85' (5.14 m)
39'	2	7.5	7.5	7.5	18.79' (5.73 m)	2	7.5	7.5	7.5	17.85' (5.44 m)
40'	2	7.5	7.5	7.5	18.79' (5.73 m)	2	7.5	7.5	7.5	18.75' (5.72 m)
42'	2	7.5	7.5	7.5	19.79' (6.04 m)	2	7.5	7.5	10	19.85' (6.05 m)
43'	2	7.5	7.5	7.5	20.79' (6.34 m)	2	7.5	7.5	10	19.85' (6.05 m)
45'	2	7.5	7.5	7.5	20.79' (6.34 m)	2	7.5	7.5	10	20.85' (6.36 m)
48'	2	7.5	7.5	7.5	22.79' (6.95 m)	2	7.5	10	10	22.85' (6.96 m)
49'	2	7.5	7.5	7.5	22.79' (6.95 m)	2	7.5	10	10	22.85' (6.96 m)
51'	2	7.5	7.5	10	23.79' (7.26 m)	2	7.5	10	10	23.85' (7.27 m)
54'	2	7.5	7.5	10	25.79' (7.86 m)	2	10	10	10	25.85' (7.88 m)
55'	2	7.5	7.5	10	25.79' (7.86 m)	2	10	10	10	25.85' (7.88 m)
57'	2	7.5	7.5	10	26.79' (8.17 m)	2	10	10	10	26.85' (8.18 m)
59'	2	7.5	7.5	10	27.79' (8.47 m)	2	10	10	15	27.85' (8.49 m)
60'	2	7.5	7.5	10	28.79' (8.78 m)	2	10	10	15	28.85' (8.79 m)
62'	2	7.5	7.5	10	29.79' (9.08 m)	2	10	10	15	29.85' (9.10 m)
63'	2	7.5	7.5	10	29.79' (9.08 m)	2	10	10	15	29.85' (9.10 m)
66'	2	7.5	7.5	10	31.79' (9.69 m)	2	10	15	15	31.85' (9.71 m)
68'	2	7.5	7.5	10	32.79' (10.00 m)	2	10	15	15	32.85' (10.01 m)
69'	2	7.5	7.5	10	32.79' (10.00 m)	2	10	15	15	32.85' (10.01 m)
72'	2	7.5	7.5	10	34.79' (10.61 m)	2	15	15	15	34.85' (10.62 m)
75'	2	10	10	10	35.79' (10.91 m)	2	15	15	15	35.85' (10.93 m)
78'	2	10	10	10	37.79' (11.52 m)	2	15	15	15	37.85' (11.54 m)
80'	2	10	10	10	38.79' (11.83 m)	2	15	15	15	38.85' (11.84 m)
81'	2	10	10	10	38.79' (11.83 m)	2	15	15	15	38.85' (11.84 m)
84'	2	10	10	15	40.79' (12.44 m)	2	15	15	15	40.85' (12.45 m)
87'	2	10	10	15	41.79' (12.74 m)	2	15	15	20	41.85' (12.76 m)
88'	2	10	10	15	42.79' (13.05 m)	2	15	15	20	42.85' (13.06 m)
90'	2	10	10	15	43.79' (13.35 m)	2	15	15	20	43.85' (13.37 m)
91'	2	10	10	15	43.79' (13.35 m)	2	15	15	20	43.85' (13.37 m)
92'	2	10	10	15	44.79' (13.66 m)	2	15	20	20	44.85' (13.67 m)
95'	2	10	15	15	45.79' (13.97 m)	2	15	20	20	45.85' (13.98 m)
98'	2	10	15	15	47.79' (14.57 m)	2	15	20	20	47.85' (14.58 m)
105'	3	15	15	20	50.79' (15.48 m)	3	20	20	20	50.85' (15.50 m)
113'	3	15	15	20	54.79' (16.70 m)	3	20	20	20	54.85' (16.72 m)
120'	3	15	15	20	58.79' (17.92 m)	3	20	20	20	58.85' (17.94 m)

Due to continual improvements, GSI designs and specifications are subject to change without notice.

NOTE: *The horsepower recommendations are for augering reasonably dry grain. High moisture grain (greater than 15%) will require greater power for maximum capacity. The maximum capacity will be less with high moisture grain than with dry grain.*

Sweep drive and carrier wheels require plates or track over aeration flooring for travel and supports not supplied with the sweep unit. Contact your installer or flooring provider for possible source and details.

2. A magnetic starter should be used to protect the motor when starting and stopping. It should stop the motor in case of power interruption, conductor fault, low voltage, circuit interruption or motor overload. The motor must be restarted manually. Some motors have built-in thermal overload protection. If this is the type of motor being used, use only those with a manual reset.
3. The motor starting controls must be located outside the bin. They must NEVER be installed on the Series II auger inside the bin.
4. Disconnect and lock out the power before resetting motor overloads.
5. Disconnect and lock out the power before entering the bin.
6. Disconnect and lock out the power before servicing the equipment.
7. Position the reset and motor starting controls so that the operators have full view of the equipment.



There should ALWAYS be two (2) people in the work area.

8. Make sure electric motors are grounded.



A main power disconnect switch capable of being locked only in the OFF position should be used. The disconnect must be locked in the off position before unplugging either end of the cord. It should also be locked whenever work is being done on the Series II Sweep. This has been integrated into the control panel after June of 2010.

5. Assembly

Docking Station Mount

Securely mount the docking station outside of the bin near the bin door. *Figure 5A* shows the hole pattern and diameter. The docking station must be close enough to the bin door to plug in the 10' long foot switch cord. The operator must be outside of the bin and be able to depress the foot switch while visually monitoring the sweep through the bin door.

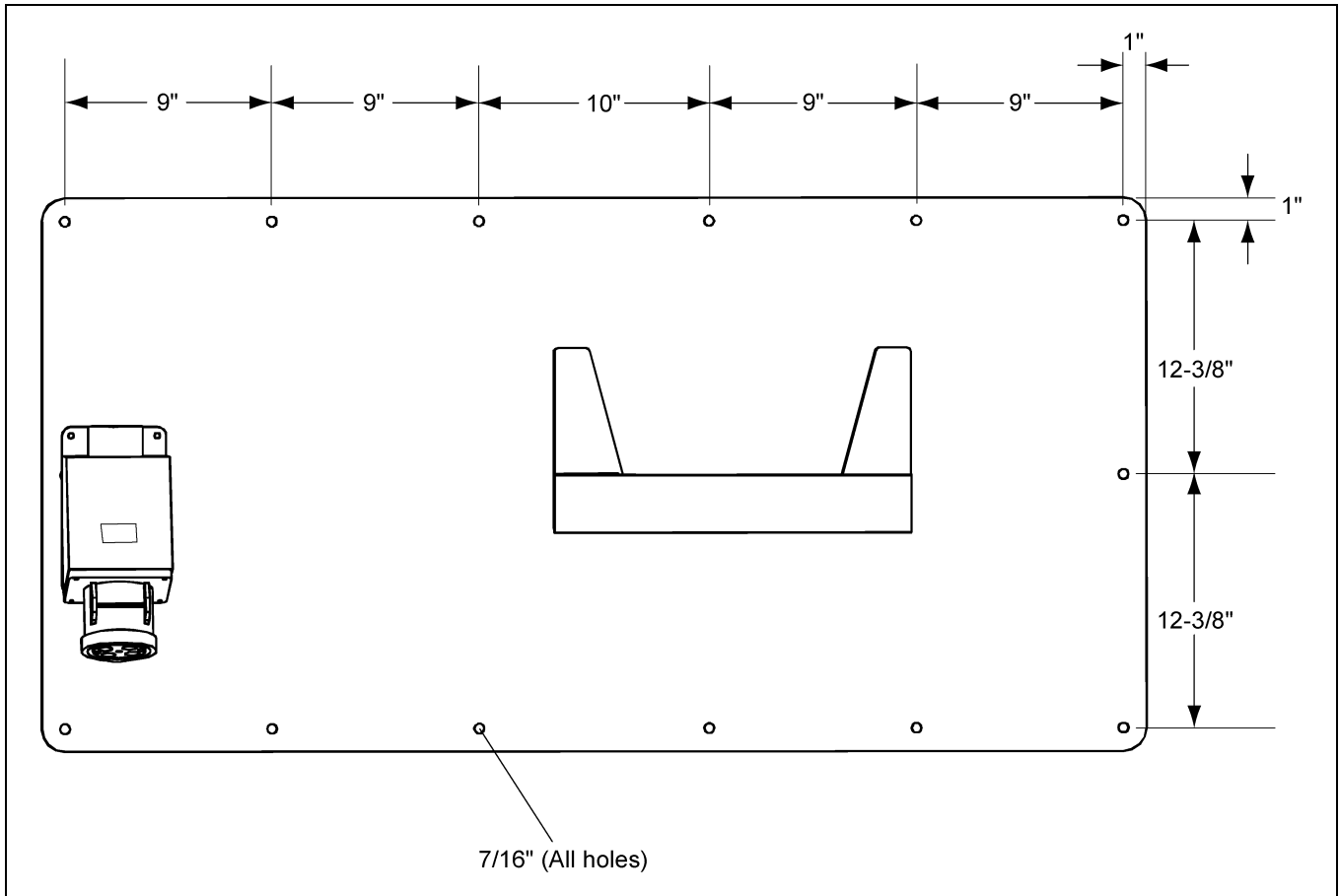

Figure 5A Docking Station



The control panel must be mounted outside the bin near the door. The foot switch has to be plugged into the control panel and depressed before the sweep is operational. It has a 10' cord so the sweep can only be monitored from outside the bin.

Control Panel Conduit Hole (Pre-June 2010)

NOTE: The Series II Sweep has used different control boxes. The quick disconnect kit will fit either style box. Hardware is provided to mount an older style box (with ears) to the mounting plate. The new style box already has hardware installed in the rear of the box.

1. Cut a hole into the side panel of the control box in the location shown in [Figure 5B](#). Hole to be sized for 1-1/2" rigid conduit (approximately 1.900"). Make sure all metal chips/shavings are removed from the inside of the box.

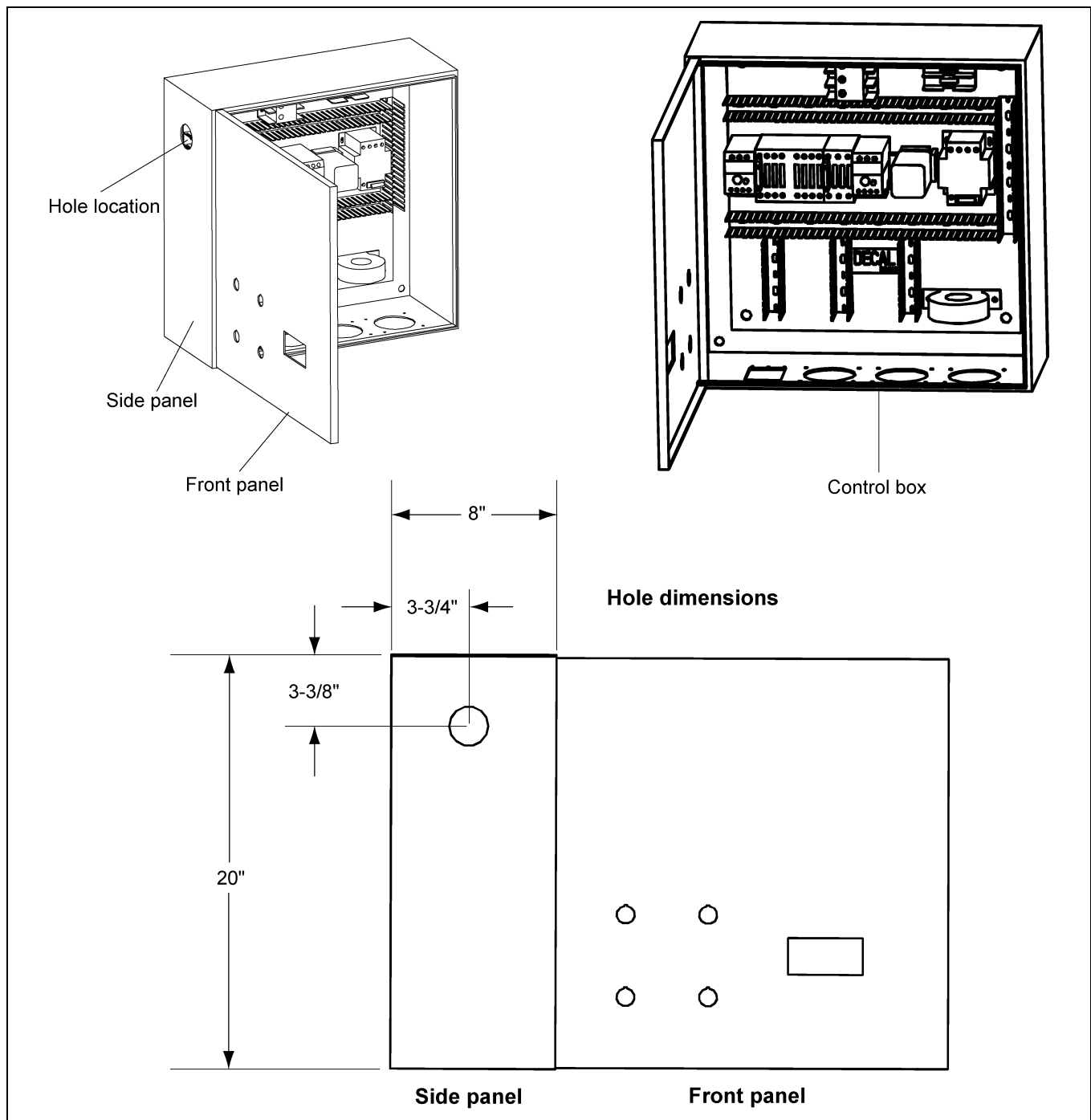

Figure 5B

Control Panel Installation



Electrical controls should be installed by a qualified electrician and must meet standards set by the National Electrical Code and all local and state codes.

A main power disconnect switch capable of being locked only in the OFF position should be used. The disconnect must be LOCKED in the OFF position before unplugging either end of the power cord. This has been integrated into the control panel after June 2010.

1. Remove the lock nut from the conduit hub. The conduit hub is factory installed on the conduit assembly attached to the back base assembly.
2. Carefully inset the conduit hub, with wires, into the hole drilled during [Step 1 on Page 19](#).
3. Install the lock nut on the hub and tighten.
4. Mount the control box to the back plate with the supplied hardware.
5. Use the supplied grounding lug (E160-1137) to properly ground the control box assembly to the outlet.

Control Panel Receptacle Mounting (Current Style Panel)



Electrical controls should be installed by a qualified electrician and must meet standards set by the National Electrical Code and all local and state codes.

A main power disconnect switch capable of being locked only in the OFF position should be used. The disconnect must be LOCKED in the OFF position before unplugging either end of the power cord. This has been integrated into the control panel after June 2010.

Control Panel and Receptacle Installation

Open the control panel and mount it to the lift base panel assembly with the supplied hardware. There are three (3) mounting positions on the lift base panel assembly in which to mount the control panel. (See [Figure 5C](#).)

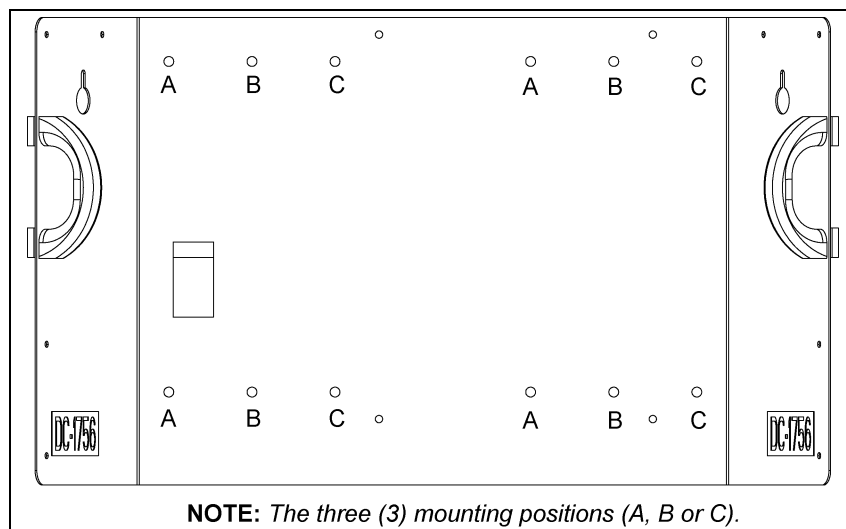

Figure 5C

Based on where the outlet for the drop cord is installed on the panel, all three (3) mounting positions may not be possible. (See Figure 5D.)

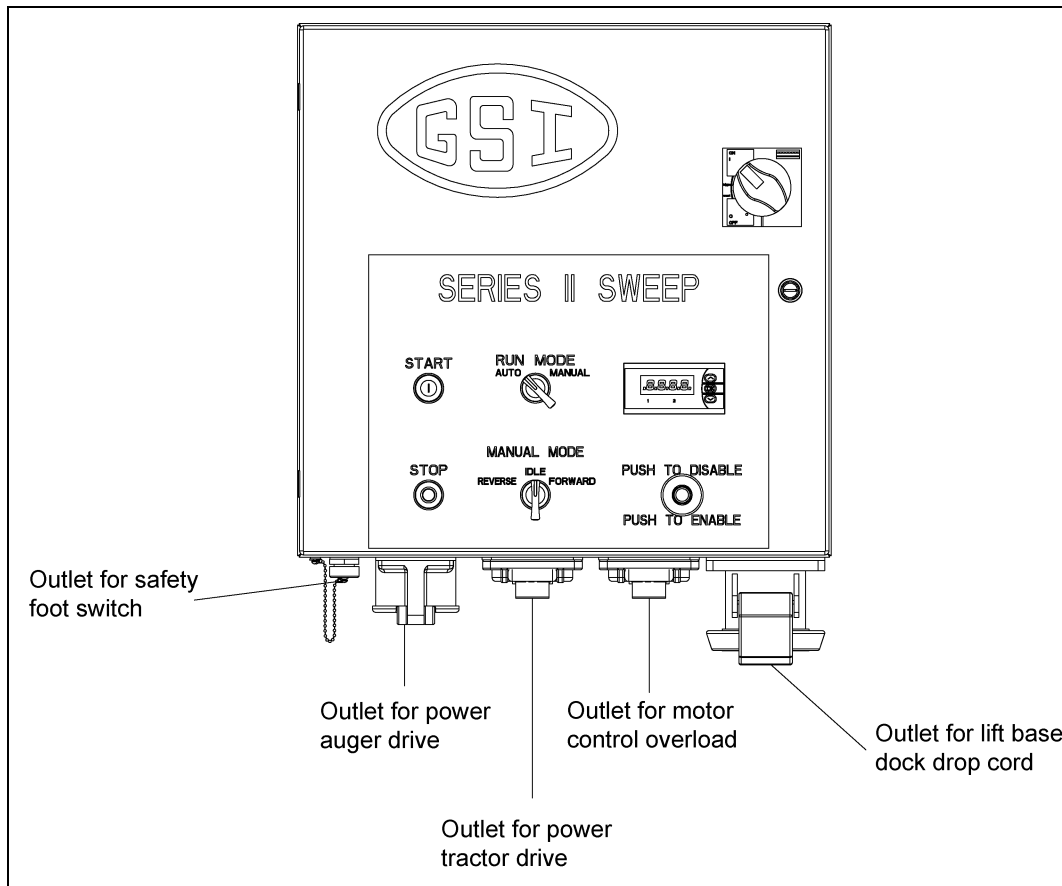

Figure 5D

A sample installation configuration is shown in Figure 5E for the auger drive power outlet, tractor drive power outlet, overload for motor control outlet and the drop cord outlet. Figure 5E shows preliminary dimensions for all the necessary holes that need to be cut into the panel. Actual sizes may vary.

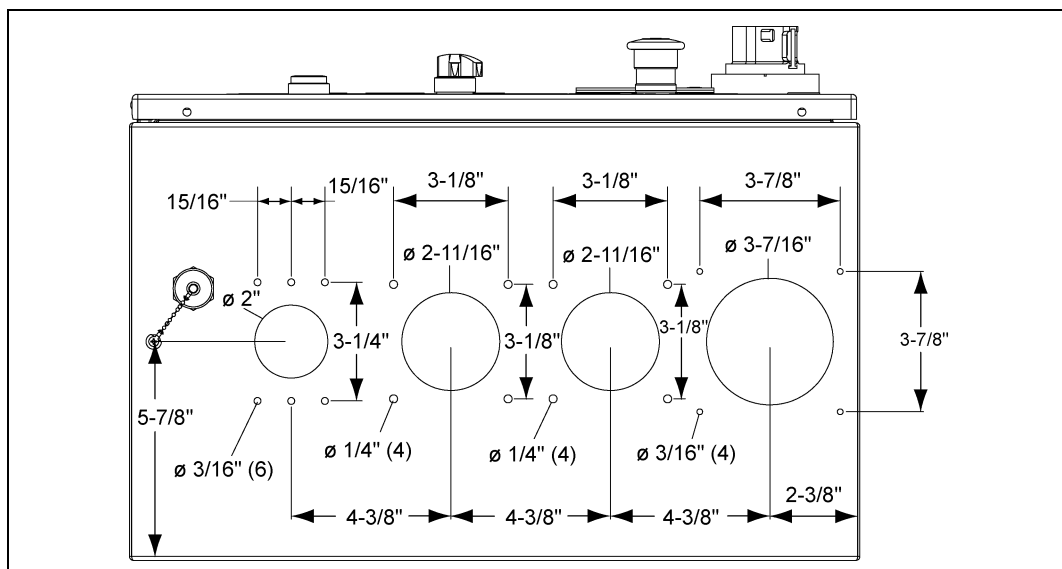

Figure 5E

5. Assembly

Install each receptacle to the panel with the supplied hardware. Consult the wiring schematic in the panel enclosure for proper electrical connection locations.

Once the receptacles have been properly installed, the auxiliary guidance handles can be attached to the panel assembly.

Guidance Handle Installation



Use 1/4"-14 x 1-1/4" screws for handles that attach to the base back plate at the stiffener bar locations. Use 1/4"-14 x 1" screws for handles that attach at all other locations. These handles are for guidance only. See Figure 1A on Page 5 for lifting instructions.

Using the wrong size screws can cause the threads to strip or not give enough support and serious injury or death can occur.

Attach handles. Four (4) handles are supplied and can be located in any of the holes on the outside edges of the back base plate. USE THE CORRECT SIZE SCREWS. (Only two (2) handles shown.) (See Figure 5F below and Figure 5G on Page 23.)

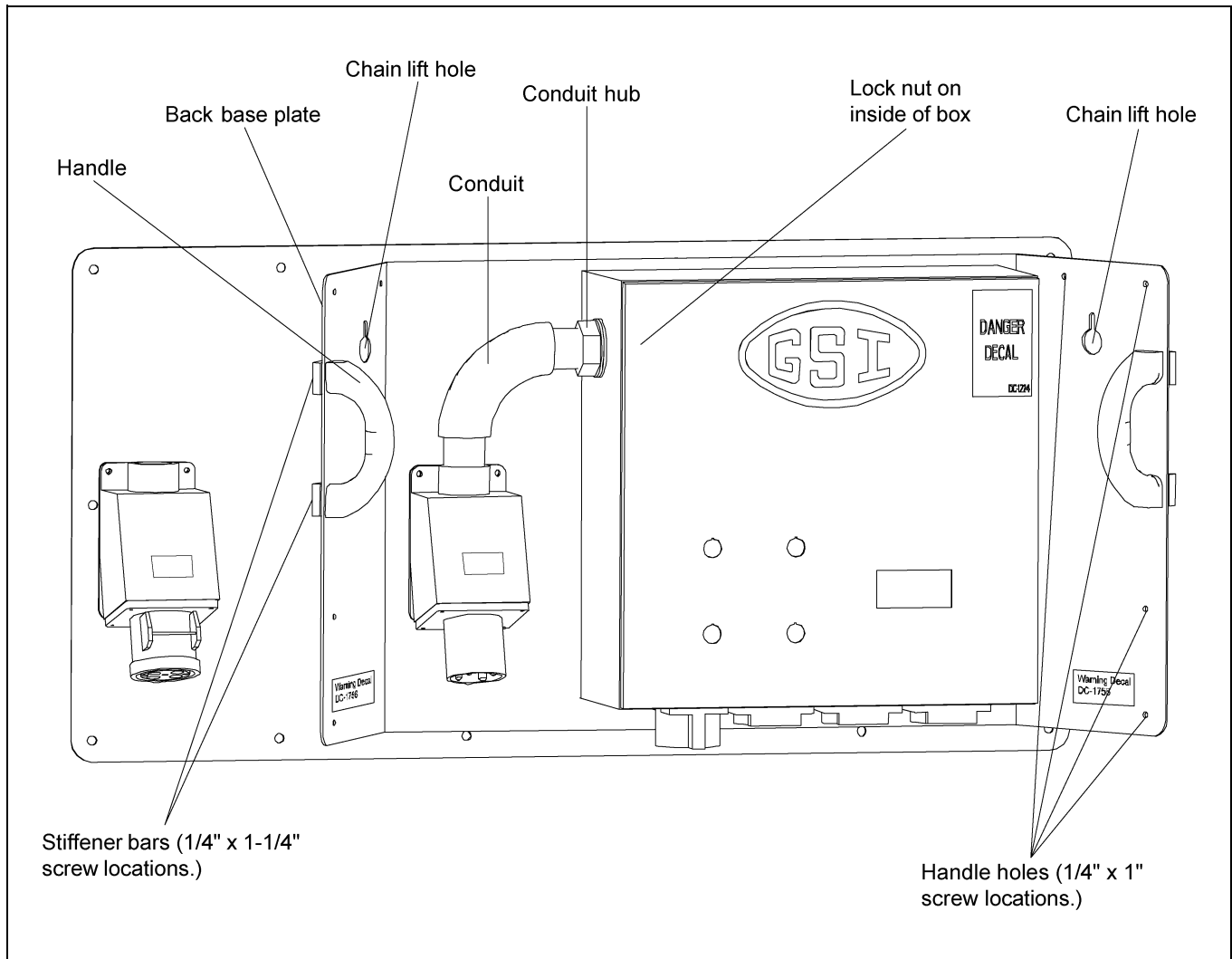

Figure 5F

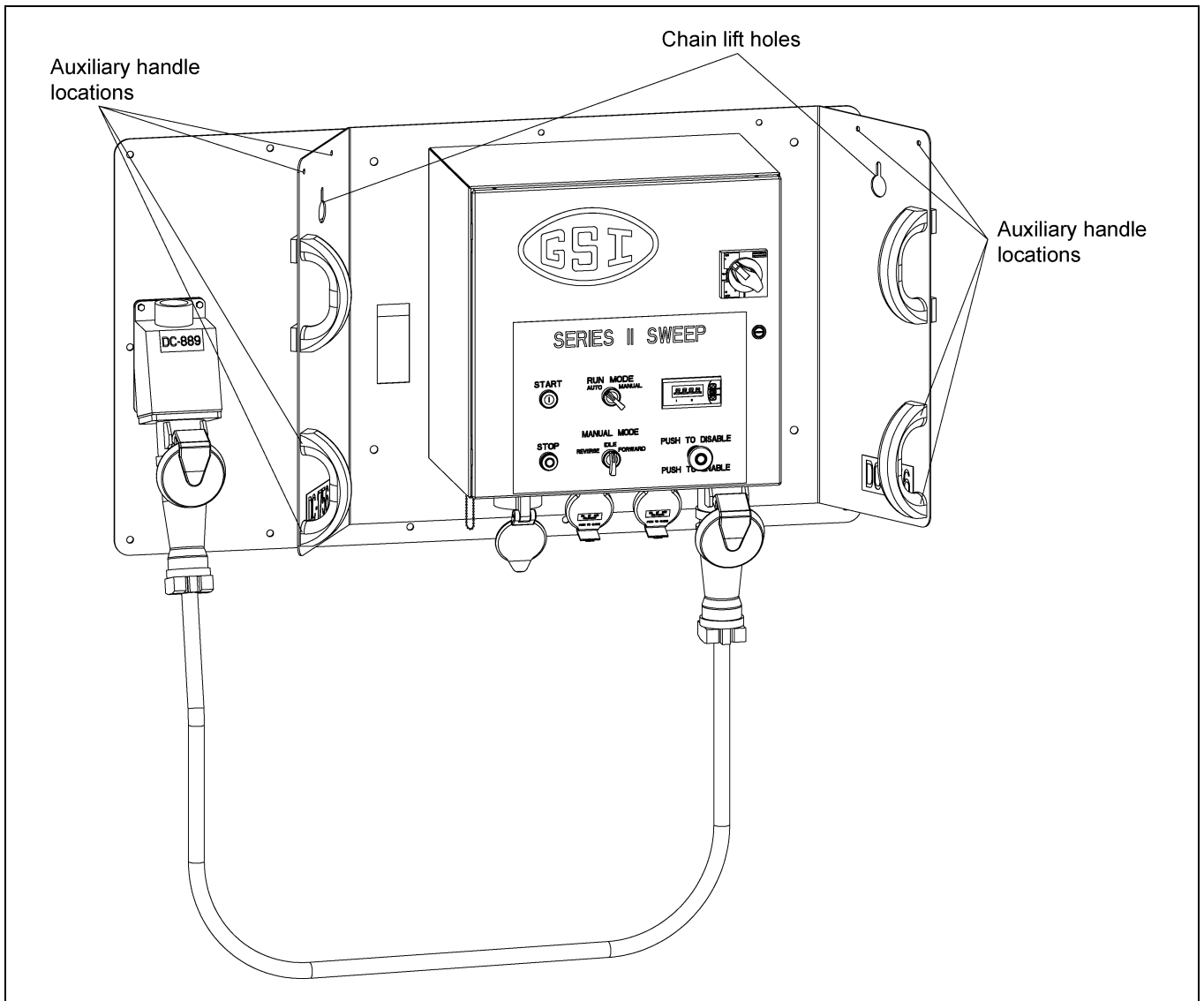

Figure 5G

5. Assembly

Place Control Panel Into Docking Station

Attach the control box to the docking station by sliding the tongue into the pocket on the docking station. (See Figure 5H.)



Do not lift equipment without personal or mechanical assistance. Single person lift could cause injury.

To avoid muscle strain or back injury, use lifting aids and proper lifting techniques when removing or replacing the control box.

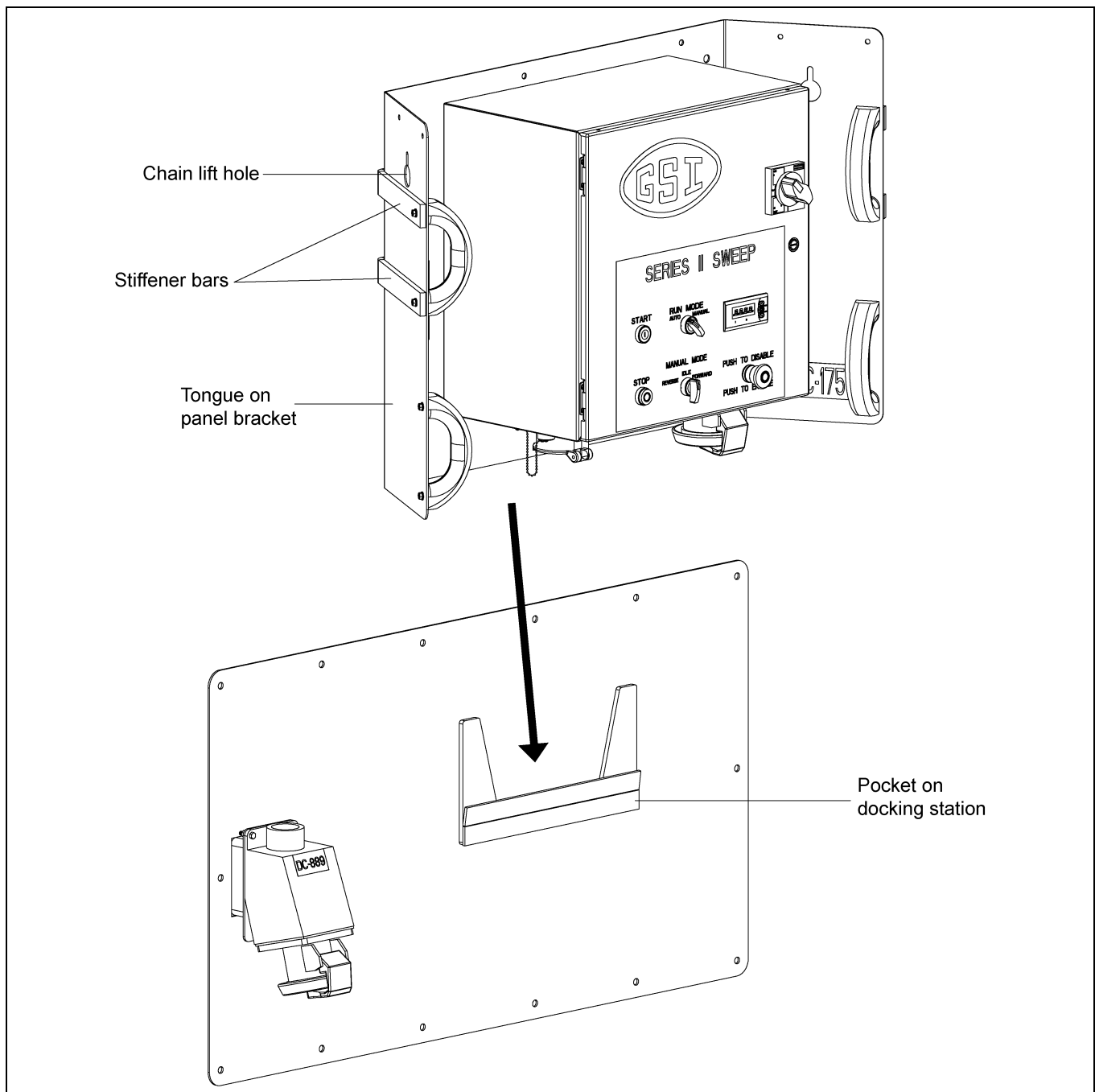

Figure 5H

Control Panel Setup

NOTE: *The control panel may have to be reprogrammed for peak performance after being moved to a different bin.*

The bin must have grain in it to be able to properly fine tune the control panel.

If the meter looks like this:

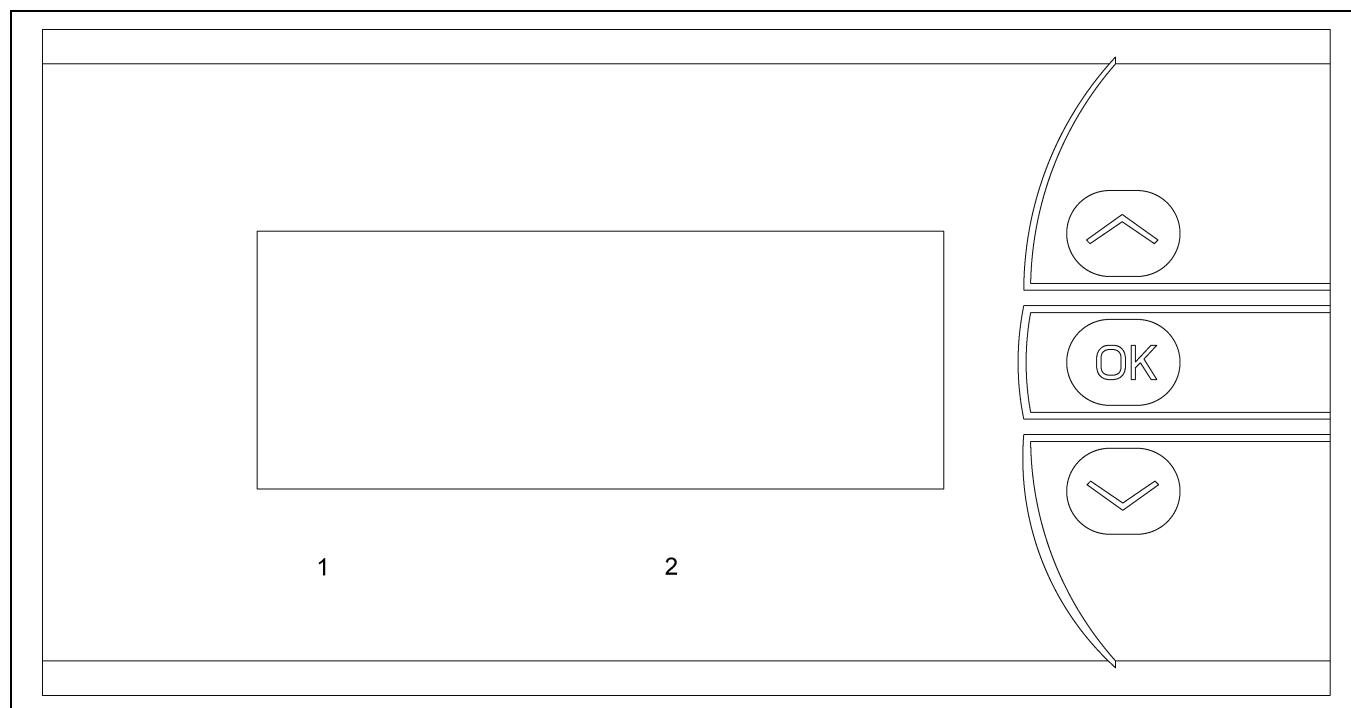

Figure 5I

Control Panel Calibration

Observe the tractor drive motor nameplate and the auger drive motor nameplate.

Record the full load amp (FLA) value for the specific voltage on each motor.

Auger drive motor full load amps: ____

Tractor drive motor full load amps: ____

Switch the disconnect switch on the panel to OFF (not ON).

Unlock and open the control panel.

Adjust the FLA dial screw on the tractor drive motor contactor (M1) and the auger drive motor contactor (M2) so that the indicator arrowhead is set slightly higher than the full load amp value listed on the nameplates.

Tractor drive motor contactor (M1) FLA adjustment dial: ____

Auger drive motor (M2) FLA adjustment dial value: ____

Close and lock the control panel.

Switch the disconnect switch on the panel to ON (not OFF).

5. Assembly

Initial Display Setup

NOTE: *If no keys are activated for 2 minutes, the display returns to the default state without saving any configuration changes. At each value, after 5 seconds of inactivity, a description of the current state will scroll across the display.*

NOTE: *Pressing and hold OK will return to the previous menu or return to the default state without saving the changed values or parameters.*

Press OK on the display unit.

(IN) should be displayed on the unit.

Press \uparrow or \downarrow on the display unit until (CURR) is shown (not VOLT, POTM, or TEMP).

Press OK.

(RANG) should be displayed on the unit.

Press \uparrow or \downarrow on the display unit until 4-20 is shown (not 0-20).

Press OK.

(DEC.P) should be displayed on the unit.

Press \uparrow or \downarrow on the display unit until 11.11 is shown (not 1111, 111.1, 1.111 or .1111).

Press OK.

(DI.LO) should be displayed on the unit.

Press \uparrow or \downarrow on the display unit until 0 is shown.

Press OK.

(DI.HI) should be displayed on the unit.

The DI.HI value is 2x the value that the FLA dial on the auger drive motor (M2) that was set earlier.

2x FLA Dial: _____

Press \uparrow or \downarrow on the display unit until the correct value is shown.

Press OK repeatedly until "-----" is displayed. This indicates the programming described above has been saved.

Make sure no individual is inside the bin.

Make sure the sweep will not contact any obstruction and cause damage.

Have an employee observe the sweep from outside the bin, through the open door.

The person observing the sweep is meant to have control over the safety foot switch.

Have another employee operate the control panel.

Switch the Run Mode switch so that Manual is selected (not Auto).

Switch the Manual Mode switch to idle (not reverse or forward).

Depress the pedal in the safety foot switch.

Press the Start button on the control panel.

NOTE: *If any damage is observed or there is abnormal operation of the sweep, shut it down immediately. There are three (3) ways to accomplish this. 1) Remove the pressure on the safety foot switch. 2) Press the Stop button on the control panel. 3) Press in on the Enable/Disable button so that it collapses appropriately. Switch the disconnect switch on the panel to OFF (not ON). Lock out the panel before entering the bin to service the sweep.*

Observe the no load amps (NLA) displayed on the meter on the front of the panel.

Auger drive motor no load amps: _____

The tractor motor operation (forward and stop) in automatic is dictated by the amp reading on the auger drive motor.

The tractor drive motor is meant to shut off (idle) when the Auger Drive Motor reaches 90% of the nameplate FLA.

90% of full load amps: _____

The tractor motor is meant to reactivate (forward) when the auger drive motor reaches 110% of the no load amps (amperage observed when the auger flight turns freely in absence of grain).

110% of no load amps: _____

Final Display Setup

NOTE: *If no keys are activated for 2 minutes, the display returns to the default state without saving any configuration changes. At each value, after 5 seconds of inactivity, a description of the current state will scroll across the display.*

Press OK repeatedly until RELU is displayed on the unit.

Press ↑ or ↓ on the display unit until DISP is shown (not PERC).

Press OK.

REL1 should be displayed on the unit.

Press ↑ or ↓ on the display unit until SET is shown (not SKIP, or OFF).

Press OK.

SETP should be displayed on the unit.

Press ↑ or ↓ on the display unit the 90% of FLA value is shown.

Press OK.

ACT1 should be displayed on the unit.

Press ↑ or ↓ on the display unit until INCR is shown (not DECR).

Press OK.

5. Assembly

HYS1 should be displayed on the unit.

For this control panel hysteresis (HYS1) is measured as the different between 90% of full load amps and 110% of no load amps.

90% of full load amps: _____ minus 110% of no load amps: _____

Press \uparrow or \downarrow on the display unit until the correct value is shown.

Press OK.

ERR1 should be displayed on the unit.

Press \uparrow or \downarrow on the display unit until DEAC is shown (not HOLD, ACTI, or NONE).

Press OK.

ON.DE should be displayed on the unit.

Press \uparrow or \downarrow on the display unit until 0 is shown.

Press OK.

OF.DE should be displayed on the unit.

Press \uparrow or \downarrow on the display unit until 20 is shown.

Press OK.

REL2 should be displayed on the unit.

Press \uparrow or \downarrow on the display unit until OFF is shown (not SET or SKIP).

Press OK.

E.PAS should be displayed on the unit.

Press \uparrow or \downarrow on the display unit until NO is shown.

Press OK.

This function will allow the values that were entered to be locked.

NOTE: *Using a password will stop access to the menu and parameters. There are two (2) levels of password protection. Passwords between 0000 and 4999 allow access to the fast set point adjustment and relay test. (Using this password stops access to all other parts of the menu.) Passwords between 5000 and 9999 stop access to all parts of the menu, fast set point adjustment and relay test. (Current set point is still shown.) By using the master password 2008, all configuration menus are available.*

If you select NO, press OK.

If you select YES, N.PAS will be displayed. Press ↑ or ↓ on the display unit until your password is shown. Press OK. Document this password.

The password will be necessary if there needs to be changes to many of the configuration values.

If the meter looks like this:

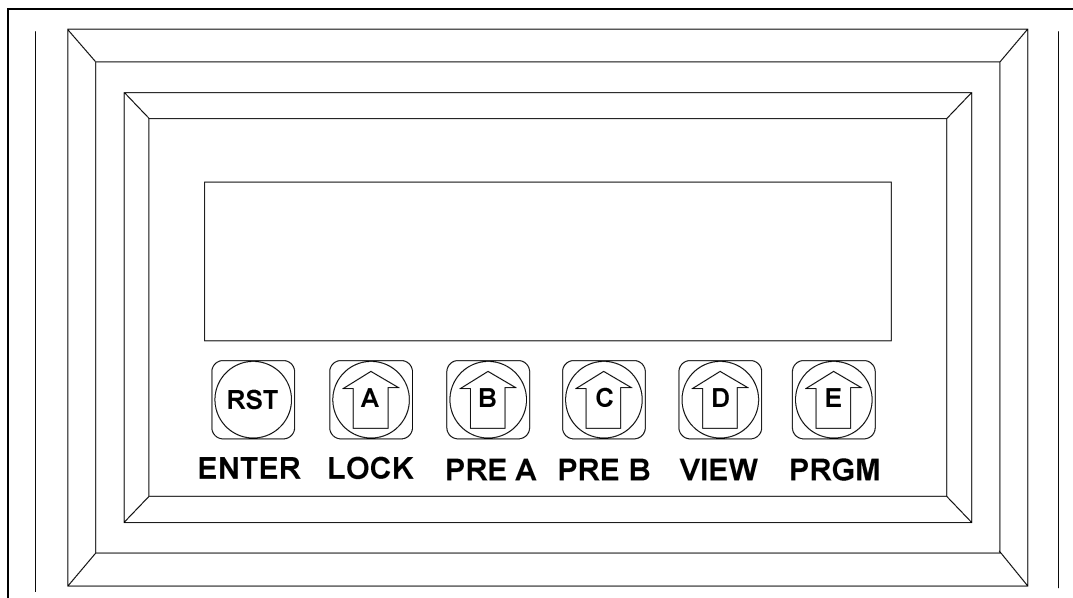

Figure 5J

Follow these instructions:

NOTE: In order to fine tune the control panel, the bin must have grain in it.

The Series II Sweep is supplied with adjustable overloads that are not set at the factory. These should be set slightly higher than the Full Load Amp (FLA) value listed on the motor nameplates.

A. Find the desired “High” Amp and “Low” Amp set points.

1. **High Amp Set Point:** The Amp load the auger draws when the auger flighting is 90% loaded. This will turn OFF the tractor drive motor. Initially, set the value to 90% of the Full Load Amps (FLA) listed on the motor nameplate.
2. **Low Amp Set Point:** The Amp load the auger motor draws when the auger flighting is 10% loaded. This will turn ON the drive motor. Initially, set this value to 10% over the Amp draw of the sweep running empty.



NEVER program the “High Amp Set Point” greater than the full load running Amps of the auger motor.

B. Programming the Amp Meter.

Calibration

1. Setting Input

- a. Press "PRGM" to "inPut".



- b. Press "ENTER".

- c. Press "PRGM" to "i4-20".



- d. Press "ENTER" to RUN MODE.



2. Setting Setup

- a. Press "PRGM" to "SEtUP".



- b. Press "ENTER" to "rdEC".

Use arrow buttons to change the decimal placement. Show .0 Amps.



- c. Press "ENTER" to "SETLO".

- d. Press "ENTER"

Value = 0.0



- e. Press "ENTER" to "SEtHi".

- f. Press "Enter"

Value = 50.0



Use arrow buttons to change value.

- g. Press "ENTER" to "LoCut".

Press "ENTER"

This value = 0



- h. Press "ENTER" to RUN MODE.



Operation

1. Setting Presets

a. Press “Pre A”.

b. Press “PRGM”

This value = “High Amp Set Point”.

Use arrow buttons to change value.

c. Press “ENTER”.

2. Setting Relays

a. Press “PRGM” to “rELAYS”.

b. Press “ENTER” to “HYS A”.

c. Press “PRGM”

This value = “High Amp Set Point”-“Low Amp Set Point”

Use arrow buttons to change value.

d. Press “ENTER” to RUN MODE.



EXAMPLE: Full Load Running Amps = 21 Amps

High Amp Set Point = 20 Amps

Low Amp Set Point = 12 Amps

Then “HYS A” = 8 Amps

And “Pre A” = 20 Amps

NOTE: *This is the difference between the High Amp Set Point and the Low Amp Set Point. [20 Amps-12 Amps = 8 Amps]. Low amp set point is only used to calculate this value.*

3. Locking the Amp Meter

1. Locking the Amp meter is not required but prevents the meter from being tampered with once it is programmed.

2. In RUN MODE, press “LOCK” three (3) times within five (5) seconds.

This value = A number that is easily remembered.

Use arrow buttons to change value.

a. Press “ENTER”.

4. Unlocking the Amp Meter

1. In RUN MODE, press “LOCK” three (3) times within five (5) seconds.

a. Enter the “LoC” value.

Use arrow buttons to change value.

b. Press “ENTER”.

NOTE: *It is recommended to write down the “LoC” value and keep it in a safe place in case it is forgotten.*

6. Start-Up

Perform Pre-Start Checks



To ensure that the drive is not unexpectedly started, turn OFF and lock out the power source before proceeding. Failure to observe these precautions could result in bodily injury.



*Failure to perform any or all of these pre-start checks may cause damage to the equipment and/or cause **SERIOUS INJURY** or **DEATH** to those in the work area.*

Failure to perform any or all of these pre-start checks may also be a misuse of the equipment. Any misuse of the equipment may void the warranty.



***ALWAYS** keep **ALL** guards and shields in place, until all the power is disconnected and locked out.*

1. Make sure ALL shields are in place.
2. Inspect the drive unit for any problems or potential problems.
3. Be aware of any emergency shut down procedures. Two (2) people must always be in position to monitor the operation of the equipment from outside the bin.
4. Before starting the auger for the first time, make sure that all parts are assembled correctly according to the instructions in this manual.



Be sure to remove the grain from the drive chain and sprockets. If this is not done, damage can occur to the drive system.



*Make certain **ONLY** trained operators are in the work area before operating or moving the machine. Two (2) people must always be in position to monitor the operation of the equipment from outside the bin.*

Start the Auger



DO NOT start or stop the auger while it is under load.

1. Plug the two (2) motors, foot switch and thermal protection cords into the bottom of the control panel while making sure they are locked into the receptacles. Each plug is different and can only be plugged into one receptacle to prevent accidental electric shock and/or overloads.
2. Step on the foot switch and press the “Start” button.
3. Run the auger through a “break-in” period if it is being used for the first time or for the first time of the season.
4. “Polish” the flighting by running the auger at partial capacity until it is smooth, before attempting full capacity.



Failures may occur if the auger is run full before it has been “polished” during the “break-in” period.



NEVER operate the auger empty. Operating augers empty for any length of time will cause excessive wear. NEVER operate the auger at speeds higher than recommended.



Be aware of any unusual vibration or noises during the initial start-up and “break-in” period. If anything unusual is detected, immediately shut down the auger and disconnect and lock out the power supply before servicing.

Operating the Sweep Auger

CAUTION

Gear reducer is shipped without oil. Add the proper amount of the recommended lubricant before operating. Failure to observe these precautions could result in damage to, or destruction of, the equipment.



Keep out of the bin while the bin sweep auger is in operation. The rapidly moving sweep auger can cause **SERIOUS INJURY** or **DEATH**.

NOTE: *The auger capacity can fluctuate greatly under varying conditions. Moisture content, different commodities, amount of foreign matter and speeds all play a part in the performance of the auger. Twenty five percent (25%) moisture may cut capacity by as much as 40% under some conditions.*

1. Make certain there are at least two (2) people in the work area to monitor operations at all times.
2. Start the bin unloading equipment before starting the bin sweep auger.



Be alert for any unusual vibrations, noises and the loosening of any fasteners. If anything unusual is detected, immediately shut down the auger, disconnect and lock out the power source before servicing.

3. Shut down the auger as soon as the bin is empty.
4. Consideration should be given to the proper size auger for any intermittent type operations. When augers are stopped and restarted under full load, it may result in damage to the auger. Using a larger diameter auger and reducing its load level will be far better than subjecting a smaller diameter auger to big loads. If an auger is kept from absolute filling, it will make start-up easier and will convey more efficiently.



NEVER enter the bin while the bin sweep is in operation.

NEVER attempt to control the operation of the bin sweep by depressing the operating controls with shovels, brooms or any other objects.

DO NOT attempt to restrain movement of the bin sweep with ropes, bars or other devices.

NEVER allow an operator to attempt to manually restrain the bin sweep.

Operating the Sweep Auger Control Panel

A. The sweep operates in two (2) different “modes”.

1. Automatic (The auger motor runs and the drive motor runs using the Amp Meter in the control panel.)

Step on the foot switch and press the “Start” button. The auger motor will turn ON and the drive motor will turn ON only if the Amp Meter reaches the “Low” set point.

2. Manual (Overrides the Amp Meter and allows the operator to manually move the sweep.)

- a. Idle (Allows the auger motor to run, but does not move the sweep forward or reverse.)

- b. Forward (Auger motor will run and moves the sweep towards the grain.)

- c. Reverse (Stops the auger motor and moves the sweep away from the grain.)

Step on the foot switch and press the “Start” button. The auger motor will turn, but the sweep will not move. Turn the “Manual” switch to “Forward” and the sweep will move forward towards the grain. Turn the “Manual” switch to “Reverse” and the auger motor will shut off and move the sweep backwards away from the grain.

The “Start” button **MUST** be pressed to start the auger motor again.

NOTE: *The foot switch MUST be depressed and the thermal protection must be connected before the sweep will operate.*

8. Shut Down

Normal Shut Down

1. Before shutting down the unit, be sure the sumps and unload conveyor are empty.
2. Press the “Stop” button on the control panel.

Emergency Shut Down

1. Know how to shut down the auger in case of an emergency.
2. Step off the foot switch and press the “Stop” button.
3. Disconnect and lock out the power source.

CAUTION	<i>NEVER start the equipment under load. Doing so may cause damage. This type of damage is considered a misuse of the equipment. Any misuse of the equipment may void the warranty.</i>
----------------	--

Storage Preparation

1. Be sure the sumps and unload conveyor are empty.
2. Close the sump control gates.
3. Park the sweep behind the intermediate sumps, so that the sumps are on the auger side of the sweep.
4. Shut down the auger.
5. Make sure all fasteners are tight.
6. After allowing the motors to cool down, cover the motors with the tarps supplied with the sweep.
7. Place blocks under the frame of the sweep to help support the sweep during storage.

Maintain the Auger



ALWAYS shut down and disconnect the power supply before adjusting, servicing or cleaning the equipment.

- A. Use caution when repairing or replacing equipment parts.
- B. Make sure ALL decals are legible and securely attached to the auger. If necessary, replace them **FREE OF CHARGE** by contacting GSI at:

GSI
P.O. Box 20
1004 E. Illinois St.
Assumption, IL 62510
Phone: 1-217-226-4421

- C. Ensure that ALL electric motors, etc. are operating at the proper speed.
- D. Make sure ALL electrical wiring is not damaged and that it meets proper wiring codes.
- E. Make sure ALL components are in good working condition before use.

CAUTION

ALL SPEED REDUCERS ARE SHIPPED DRY. OIL MUST BE ADDED PRIOR TO OPERATION. Do not operate the unit without making sure it contains the correct amount of oil. Do not overfill or underfill with oil or injury to personnel, unit or other equipment may result.

CAUTION

Do not mix non-synthetic and synthetic oil in the unit.

10. Control Panel Diagrams

Series II Sweep Control Package - 08-32A:3-12A, Non-575V (S2PFA)

Series II Sweep Control Package - 08-32A:3-12A, Non-575V (S2PFA)				
Auger Drive Motor Amps	Tractor Drive Motor Amps	Voltage	Auger Drive HP	Tractor Drive HP
8-32	3-12	208	2 - 7-1/2	3/4-3
		230	3-10	2-3
		380	5-15	2-5
		415	5-20	3 - 7-1/2
		460	7-1/2 - 20	1-1/2 - 7-1/2

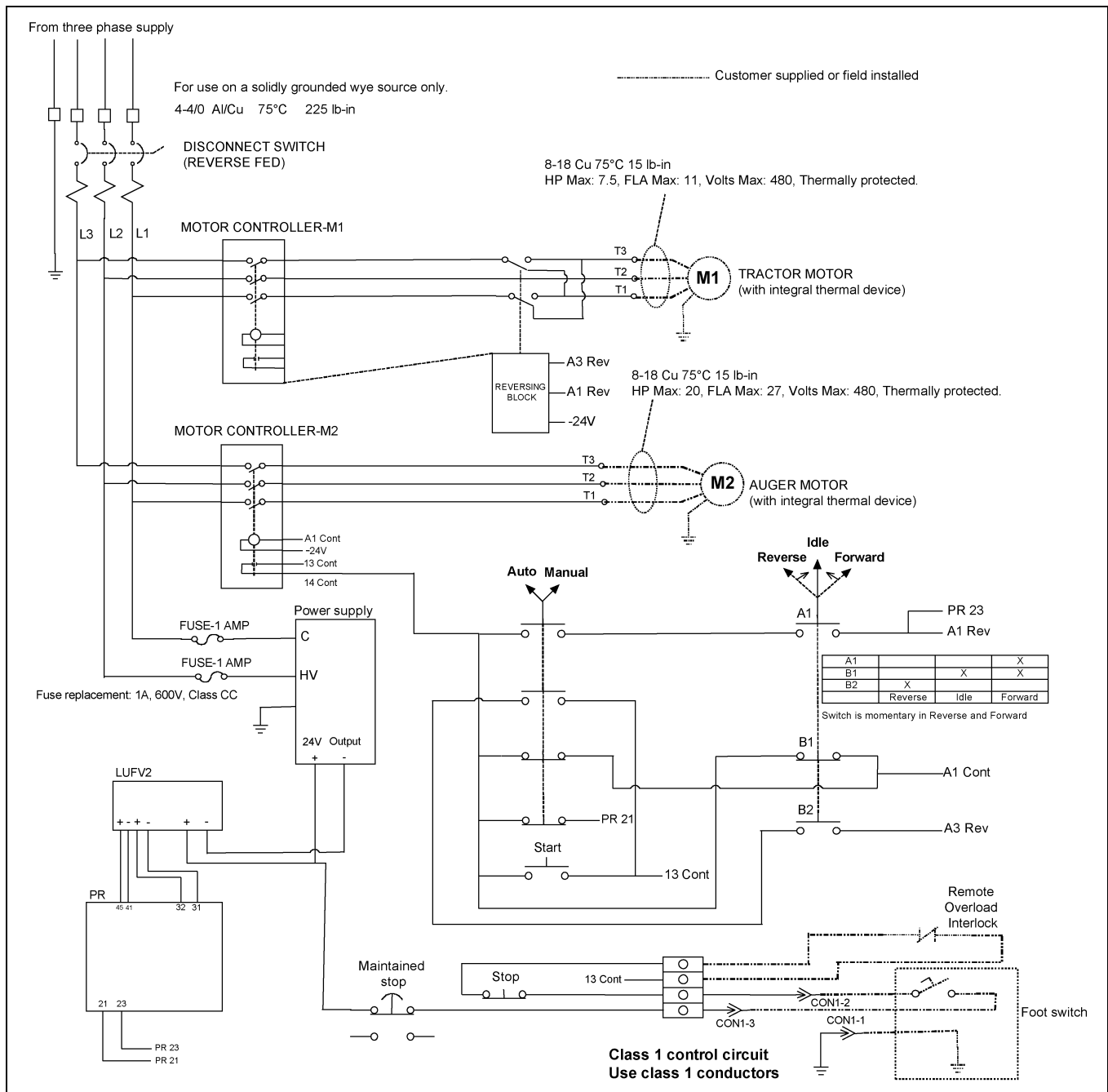

Series II Sweep Control Package - 30-40A:3-12A, Non-575V (S2PFB)

Series II Sweep Control Package - 30-40A:3-12A, Non-575V (S2PFB)				
Auger Drive Motor Amps	Tractor Drive Motor Amps	Voltage	Auger Drive HP	Tractor Drive HP
30-40	3-12	208	10	3/4-3
		230	15	2-3
		380	20	2-5
		415	20-25	3 - 7-1/2
		460	25-30	1-1/2 - 7-1/2

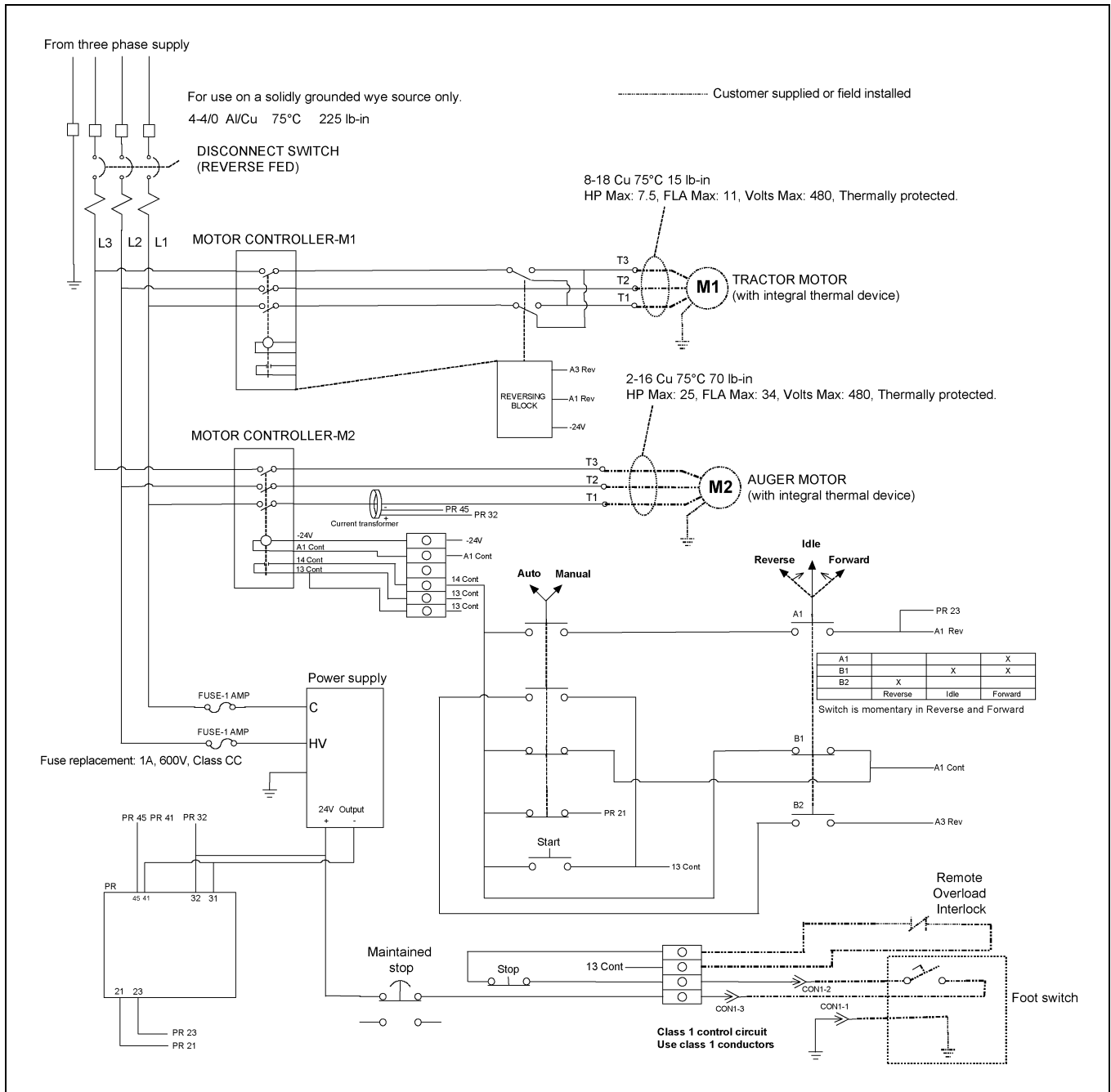

10. Control Panel Diagrams

Series II Sweep Control Package - 08-32A:3-12A, 575V Only (S2PFC)

Series II Sweep Control Package - 08-32A:3-12A, 575V Only (S2PFC)				
Auger Drive Motor Amps	Tractor Drive Motor Amps	Voltage	Auger Drive HP	Tractor Drive HP
8-32	3-12	575	7-1/2 - 30	2-10

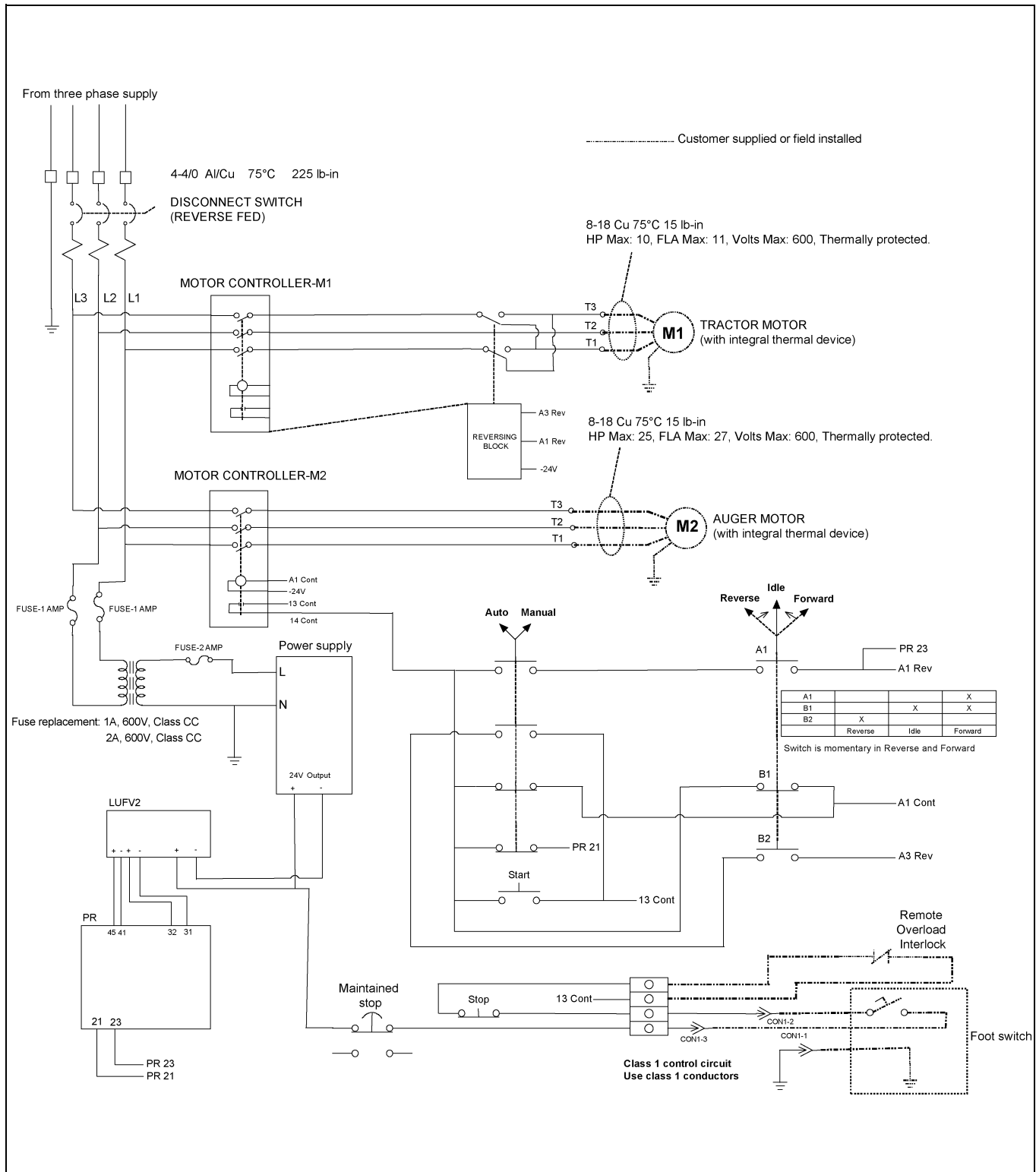

Control Panel Schematic (460/3/60) Pre-June 2010

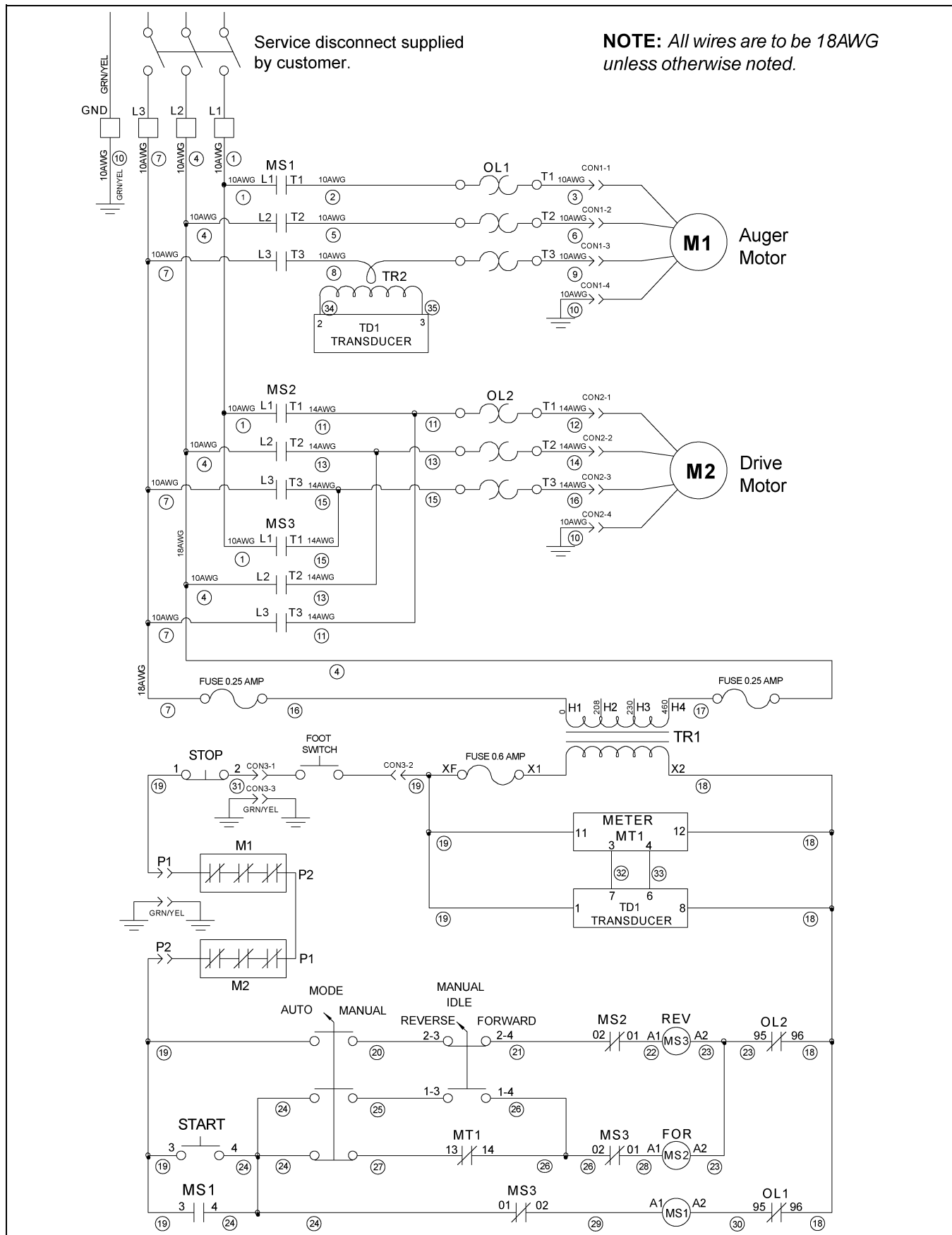

10. Control Panel Diagrams

Control Panel Schematic (230/3/60) Pre-June 2010

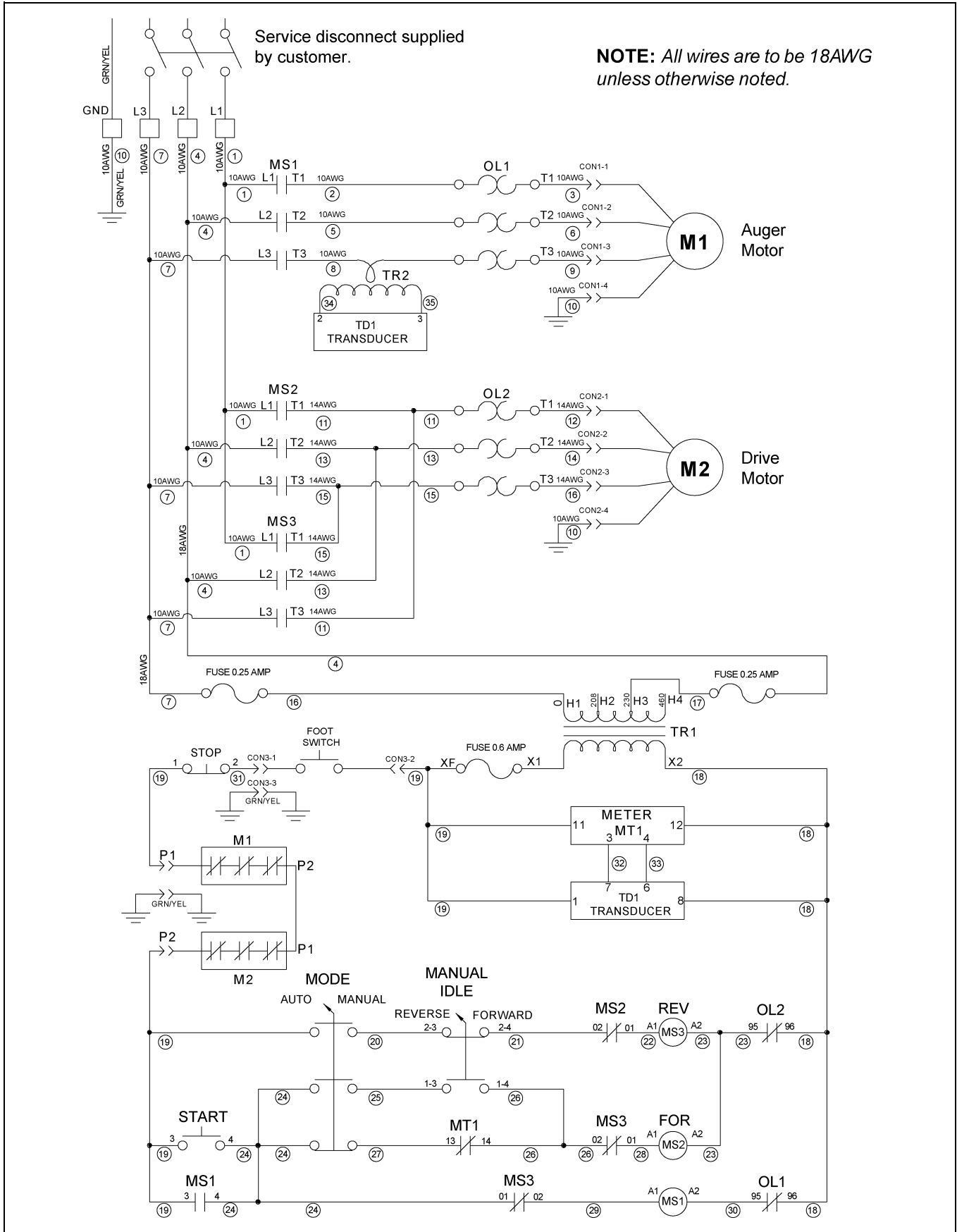

Control Panel Schematic (380/3/50) Pre-June 2010

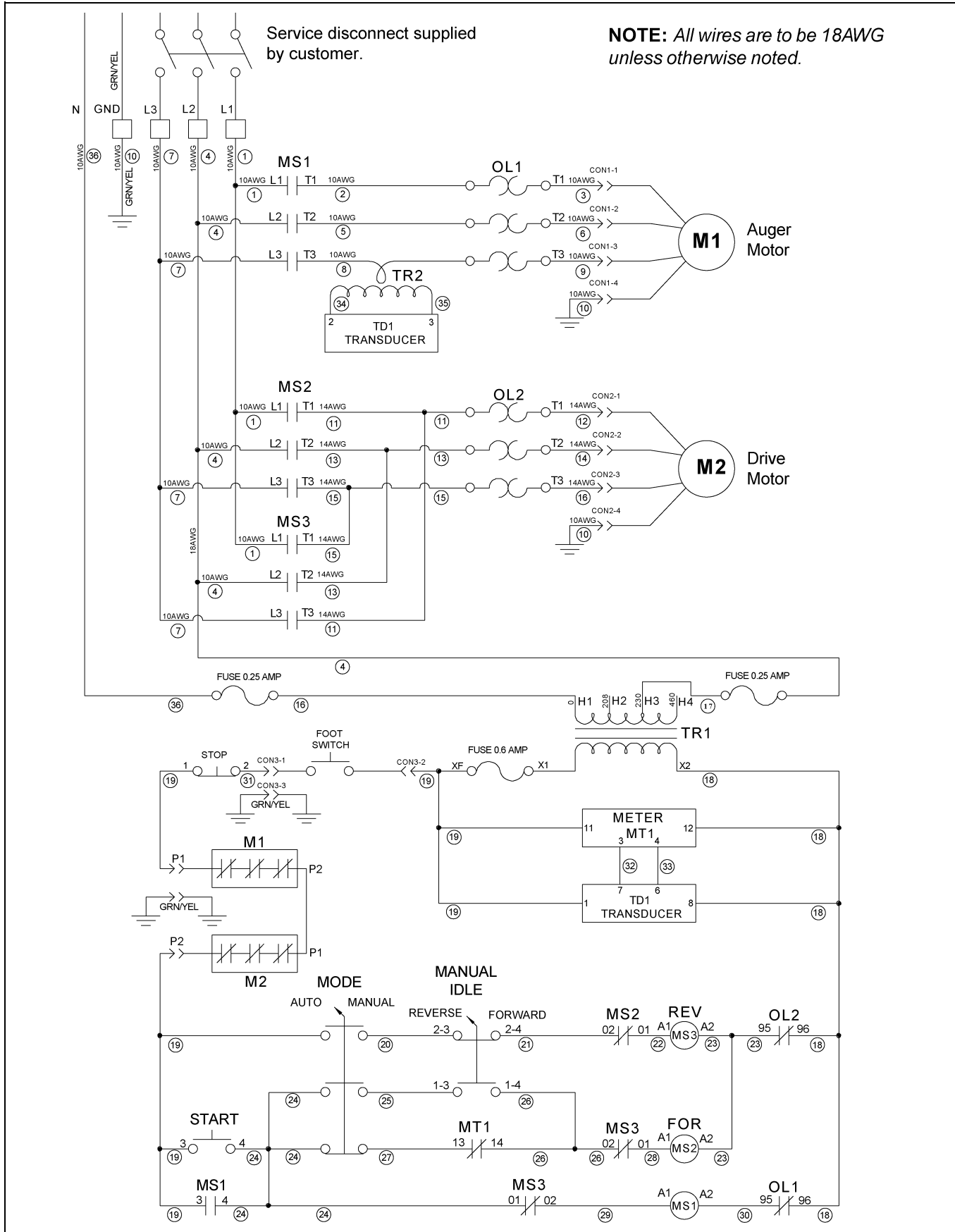

11. Troubleshooting

Problem	Possible Cause	Solution
1. Sweep does not run.	1. Power cords may be unplugged.	1. Plug in the power cords.
	2. Foot switch may not be actuated.	2. Make sure the foot switch is depressed and the switch is operating properly.
	3. Overloads may be tripped.	3. Reset the overloads.
	4. Adjustable overloads not set correctly.	4. Set overload to value listed on motor nameplate for full load amps.
2. Low capacity.	1. The auger may not be fully loaded.	1. Make sure the grain is flowing into the auger, making it fully loaded.
	2. The auger is moving too slowly.	2. Check the auger speed. Low capacity will result from speeds slower than recommended.
3. Sweep does not move around the bin.	1. The control panel may not be in "Automatic Mode".	1. Turn the switch to "Automatic Mode".
	2. The amp meter is not properly adjusted.	2. Set the amp meter so the running amps of the auger motor will turn ON the drive motor.
	3. The drive chain may be broken.	3. Repair the drive chain.
4. The sweep is vibrating.	1. The auger may have foreign materials in it.	1. Remove the foreign material.
	2. The hanger bearings may be worn.	2. Replace the hanger bearings.
	3. The flight connections may be loose.	3. Tighten all of the flight connecting bolts.
	4. The flighting may be worn.	4. Replace all the flighting sections that are worn.

1. Control Panel Components Pre-June 2010 Style Panel
2. Quick Detach Control Panel Assembly (GC10115) Pre-June 2010
3. Control Box Base Assembly (GC10109) (for Quick Detach Control Panel) Pre-June 2010
4. Dock Station Assembly (GC10116) (for Quick Detach Control Panel) Pre-June 2010
5. Conduit Assembly (GC10113) (for Quick Detach Control Panel)
6. Drop Cord Assembly (GC10079) (for Quick Detach Control Panel) Pre-June 2010
7. Quick Detach Control Panel Receptacles Parts
8. Quick Detach Control Panel Package (GK80112)
9. Lift Base Panel Assembly (GK80108)
10. Lift Base Dock Assembly (GK80110)
11. Drop Cord Assembly (GK80111)

Control Panel Components Pre-June 2010 Style Panel

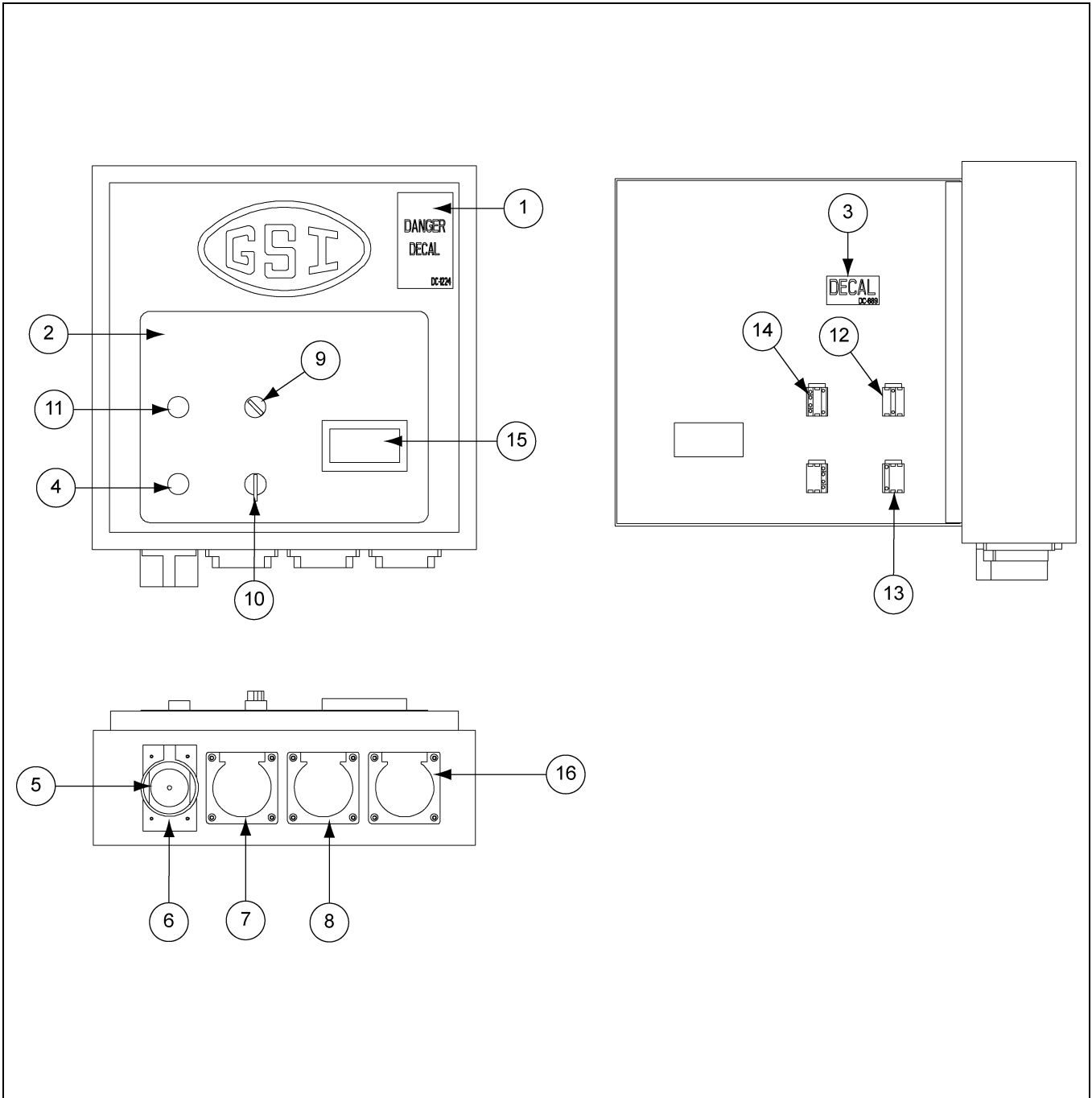

Control Panel Components Pre-June 2010 Style Panel Parts List

Ref #	Part #	Description
1	DC-1224	Decal, Danger, High Voltage
2	DC-1536	Decal, Series II Sweep Panel Overlay
3	DC-889	Decal, Danger, High Voltage
4	GC03659	Switch, Standard - Round - Push Button - Plastic - Flush - Red GE (#P9XPNRG)
5	GC03666	Receptacle, 3P4W, 50A, 3 PH, 480V - CS8169
6	GC03667	Cover, 50A Receptacles, FS/FD Mount, 1 Gang - HBL7774WO
N/S	GC03668	Plug, 3P4W, 50A, 3 PH, 480V - CS8165C
7	GC03669	Receptacle, 3P4W, 20A, 3 PH, 480V, L16-20R - HBL2430SW
N/S	GC03670	Plug, 3P4W, 20A, 3 PH, 480V, L16-20P - HBL2431SW
8	GC06954	Receptacle, 2P3W, 20A, 277V, L7-20R - HBL2330SW
9	GC06956	Blank, 2 Position - Maint - Plastic GE (#P9XSMD0N)
10	GC06957	Switch, 3 Position Lever SL Momentary GE (#P9XSVU3N)
11	GC06958	Switch, Standard - Round - Push Button - Plastic - Flush - Green GE (#P9XPNVG)
12	GC06959	Contact, Block/1 N.O./SCR
13	GC06960	Contact, Block/1 N.C./SCR
14	GC06961	Contact, Block/SCR
15	GC07585	Panel, Series II Sweep Amp Meter Device
16	GC03671	Receptacle, 2P3W, 20A, 125V, L5-20R - HBL2310SW
N/S	GC03672	Plug, 2P3W, 20A, 125V, L5-20P - HBL2311SW
N/S	GC06857	Series II Sweep Safety Foot Switch Assembly

Quick Detach Control Panel Assembly (GC10115) Pre-June 2010

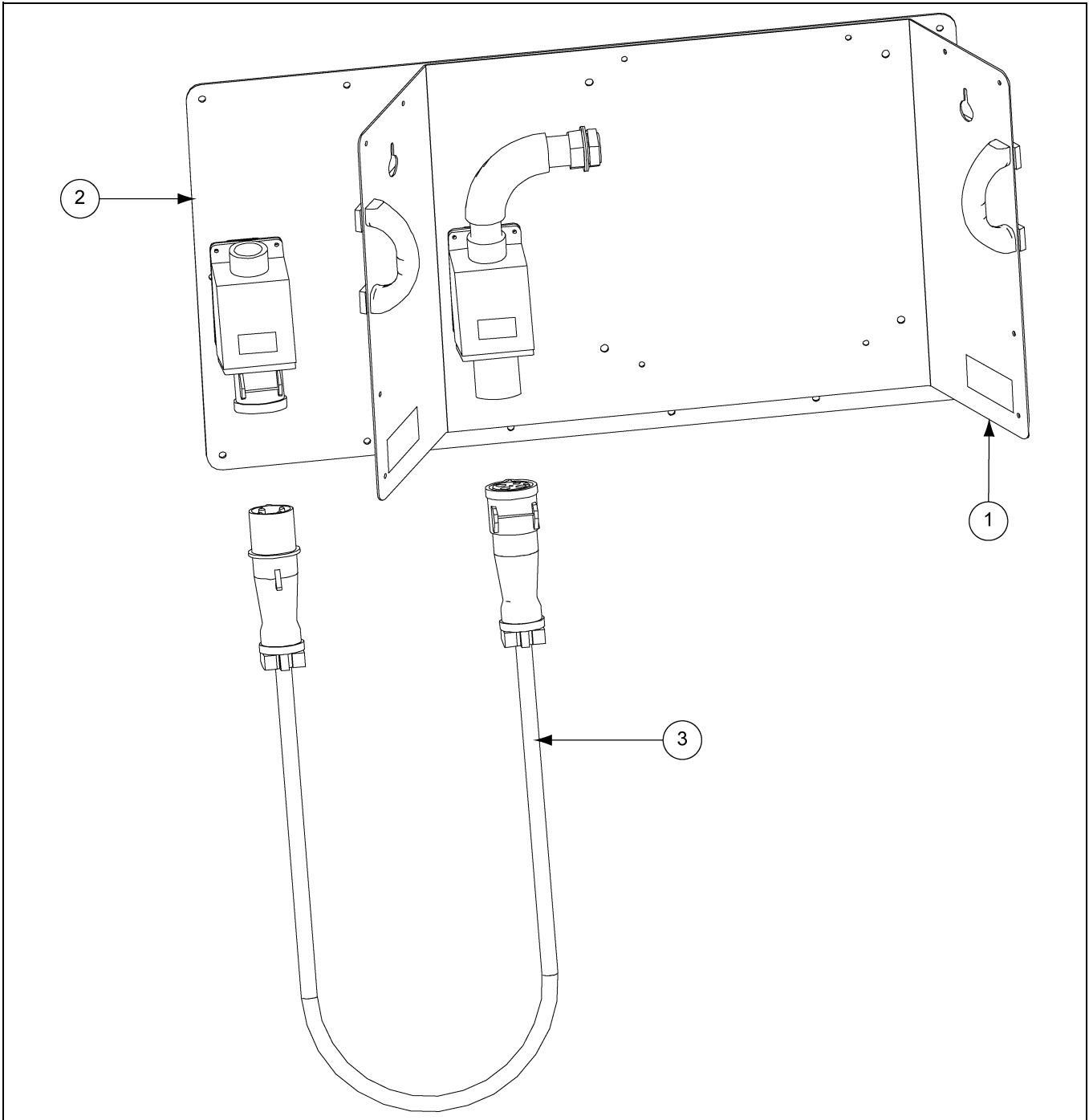

Quick Detach Control Panel Assembly (GC10115) Pre-June 2010 Parts List

Ref #	Part #	Description	Qty
1	GC10109	Control Box Base	1
2	GC10116	Dock Station Assembly	1
3	GC10079	Drop Cord	1

Control Box Base Assembly (GC10109) (for Quick Detach Control Panel) Pre-June 2010

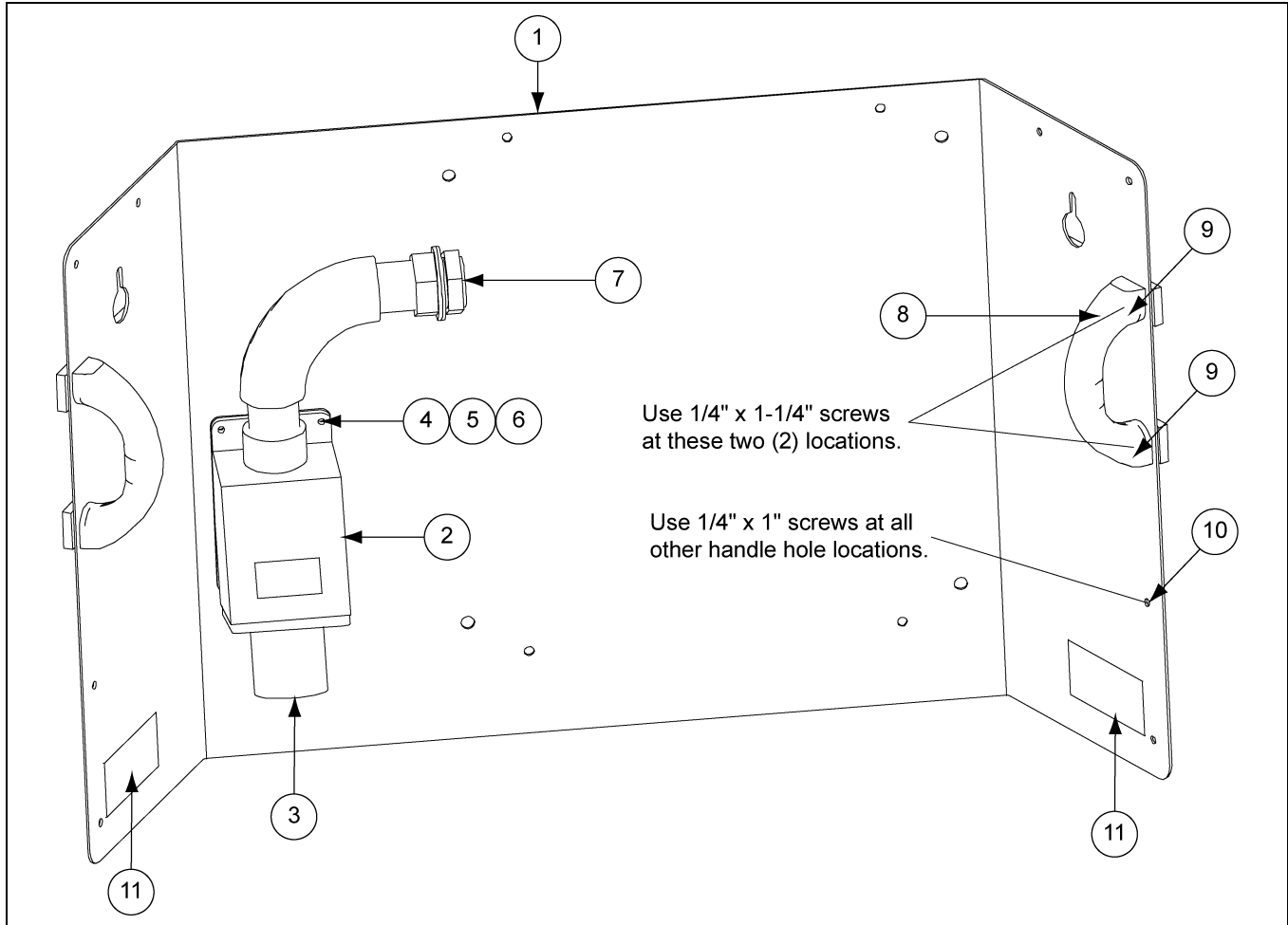

Control Box Base Assembly (GC10109) Parts List

Ref #	Part #	Description	Qty
1	GC10107	Base Back Plate Weldment	1
2	GC10071	Box, S2S2 Electrical Back BB602W 60A with 1-1/2" Hub Hubell	1
3	GC10073	Inlet	1
4	S-6998	Bolt, HHCS 1/4"-20 x 1" ZN Grade 5	3
5	S-2041	Split Lock Washer 1/4" ZN	3
6	S-1120	Hex Nut 1/4"-20 ZN Grade 5	3
7	GC10113	Conduit Assembly	1
8	F-7050	Plastic Handle	2
9	S-9315	Screw, SMSAB 1/4" x 1-1/4" HWHS ZN	4
10	S-8166	Screw, SMSAB 1/4" x 1" HWH ZN	4
11	DC-1756	Decal, Warning, Lifting Hazard	2
N/S	GC10224	Wire, 6 Gauge x 3' Stranded - Black	3
N/S	GC10225	Wire, 6 Gauge x 3' Stranded THHN - Green	1
N/S	E160-1137	Electrical Grounding Lug #TA-2 (CSA)	1

Dock Station Assembly (GC10116) (for Quick Detach Control Panel) Pre-June 2010

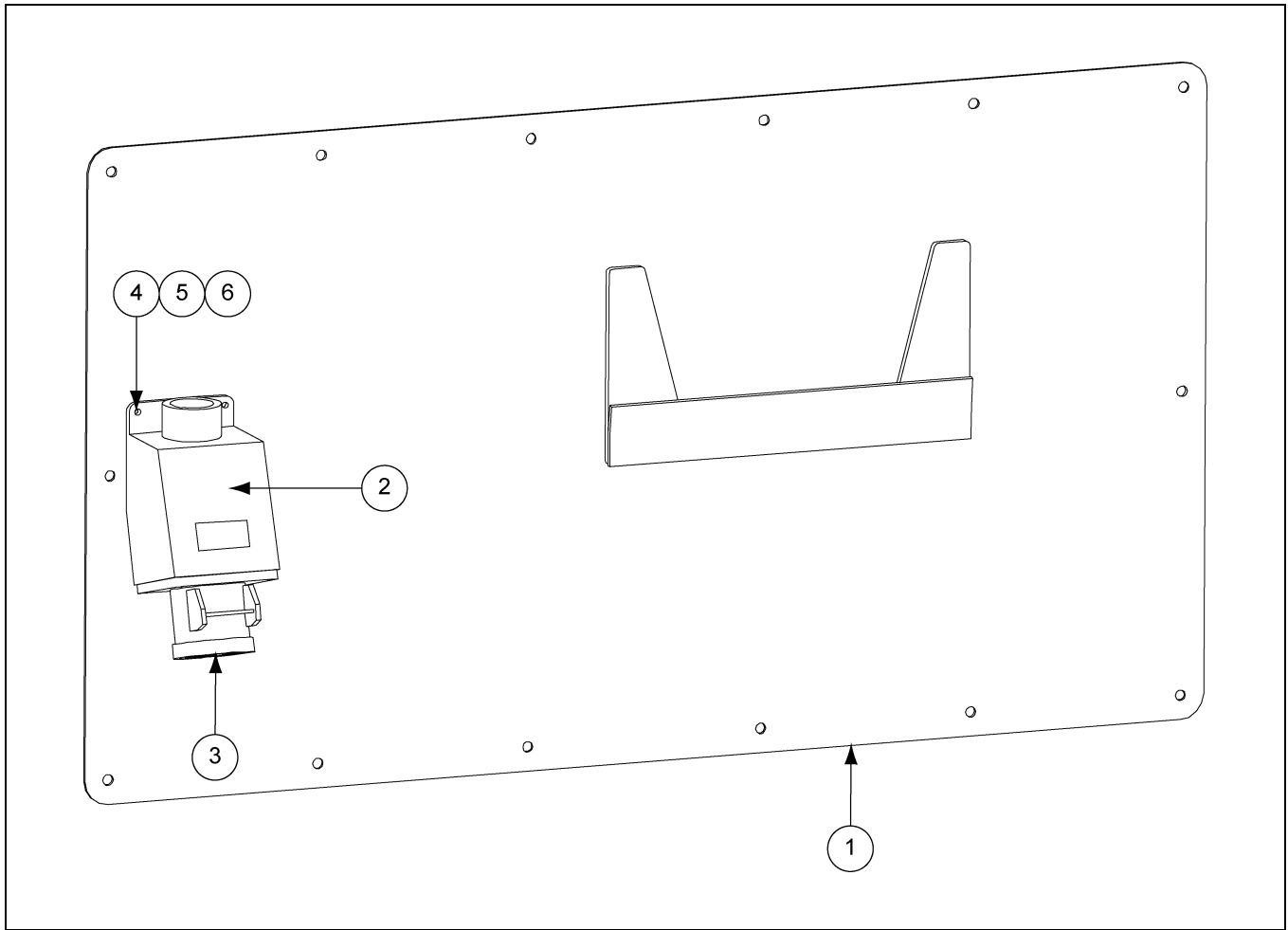

Dock Station Assembly (GC10116) Parts List

Ref #	Part #	Description	Qty
1	GC10103	S2S2 Fixed Base Weldment - Kid Control Box	1
2	GC10071	Box, S2S2 Electrical Back BB602W 60A with 1-1/2" Hub Hubell	1
3	GC10072	Receptacle	1
4	S-6998	Bolt, HHCS 1/4"-20 x 1" ZN Grade 5	3
5	S-2041	Split Lock Washer 1/4" ZN	3
6	S-1120	Hex Nut 1/4"-20 ZN Grade 5	3

Conduit Assembly (GC10113) (for Quick Detach Control Panel)

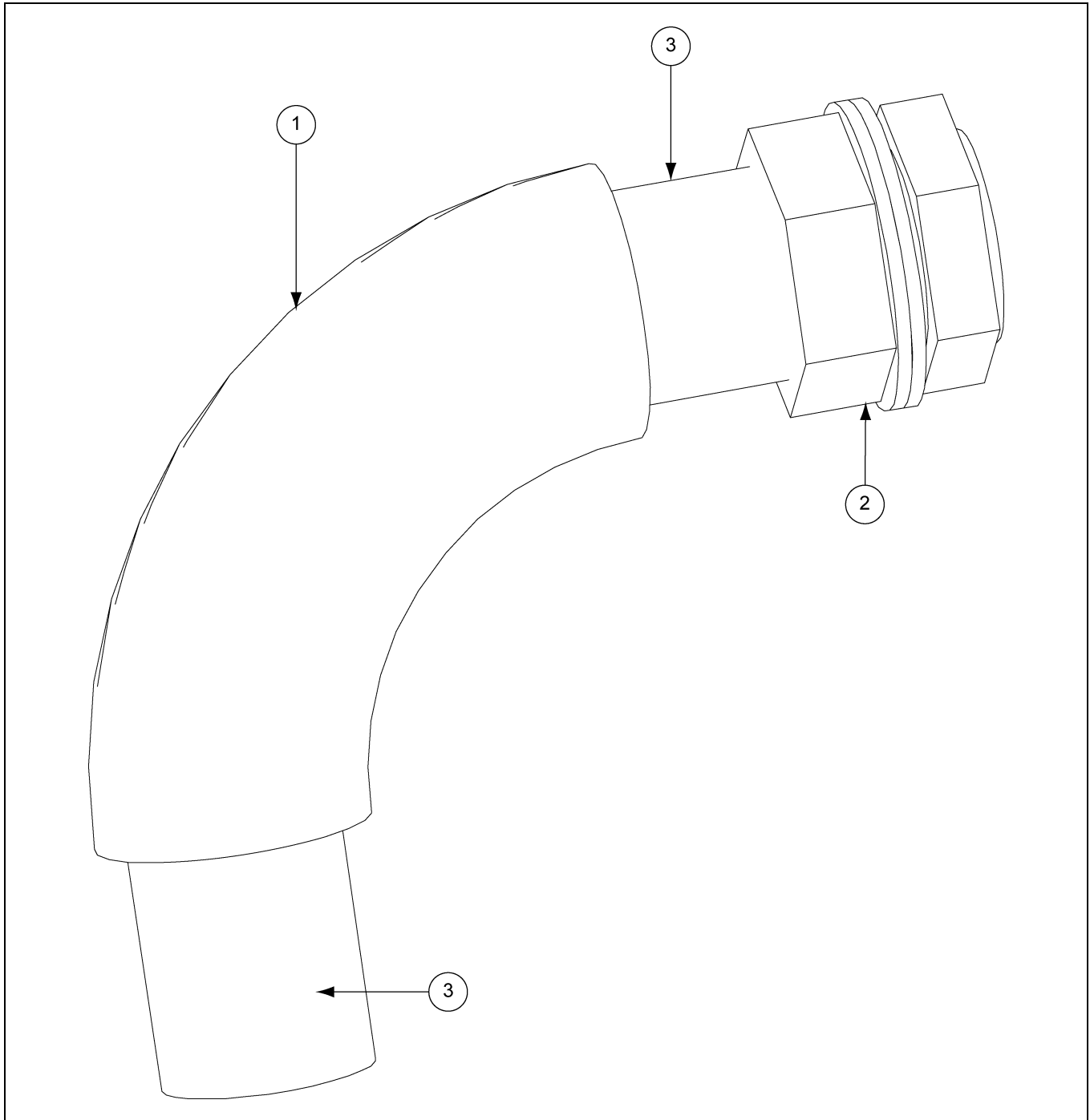

Conduit Assembly (GC10113) Parts List

Ref #	Part #	Description	Qty
1	GC10111	Elbow, 1-1/2" Conduit	1
2	GC10110	Hub, 1-1/2" Conduit	1
3	GC10112	Nipple, 1-1/2" Conduit	2

**Drop Cord Assembly (GC10079) (for Quick Detach Control Panel)
Pre-June 2010**

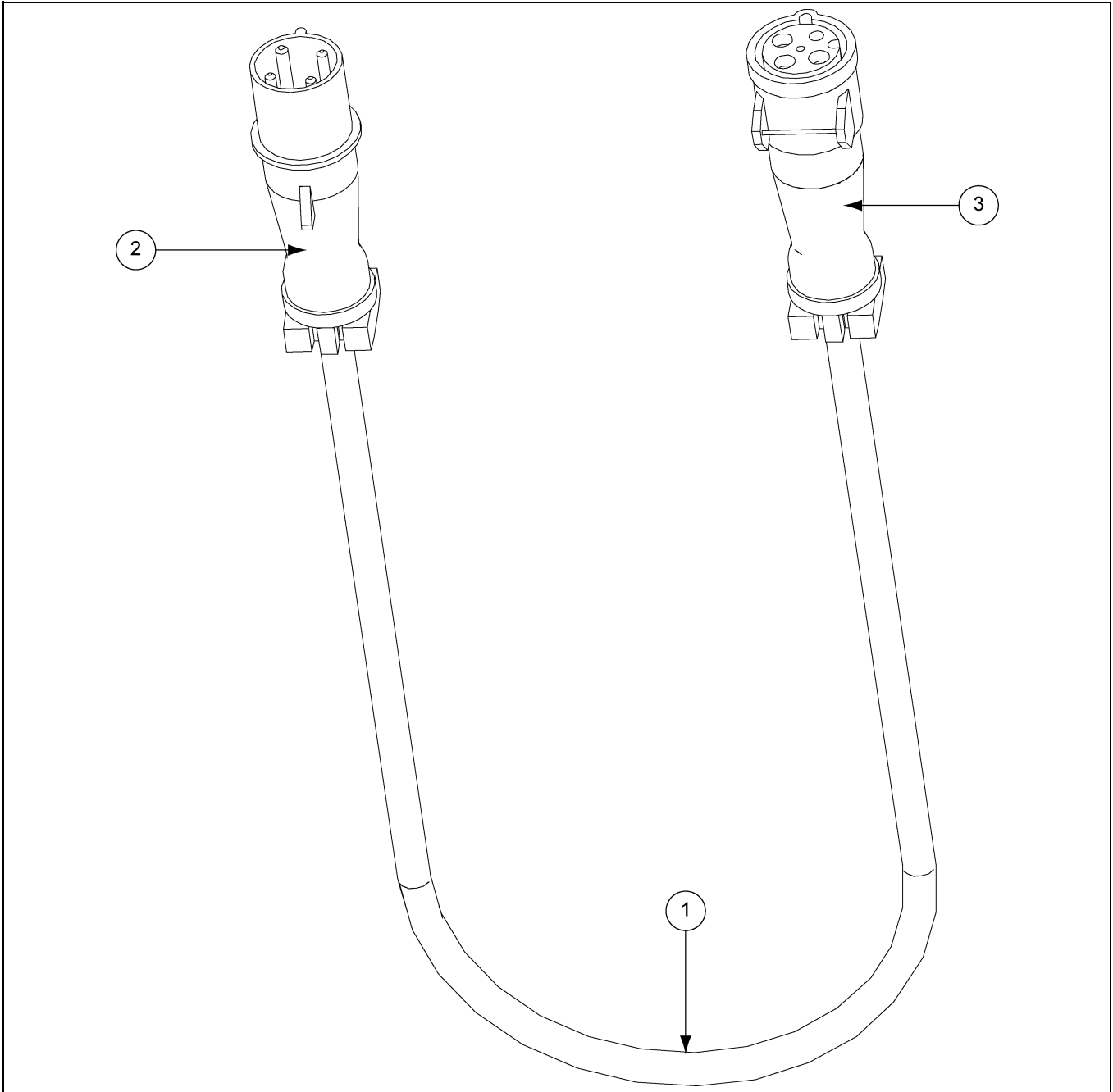

Drop Cord Assembly (GC10079) Parts List

Ref #	Part #	Description	Qty
1	GC10078	S2S2 Electrical Cable for Drop Cord	1
2	GC10074	Plug, Male	1
3	GC10075	Plug, Female	1

Quick Detach Control Panel Receptacles Parts

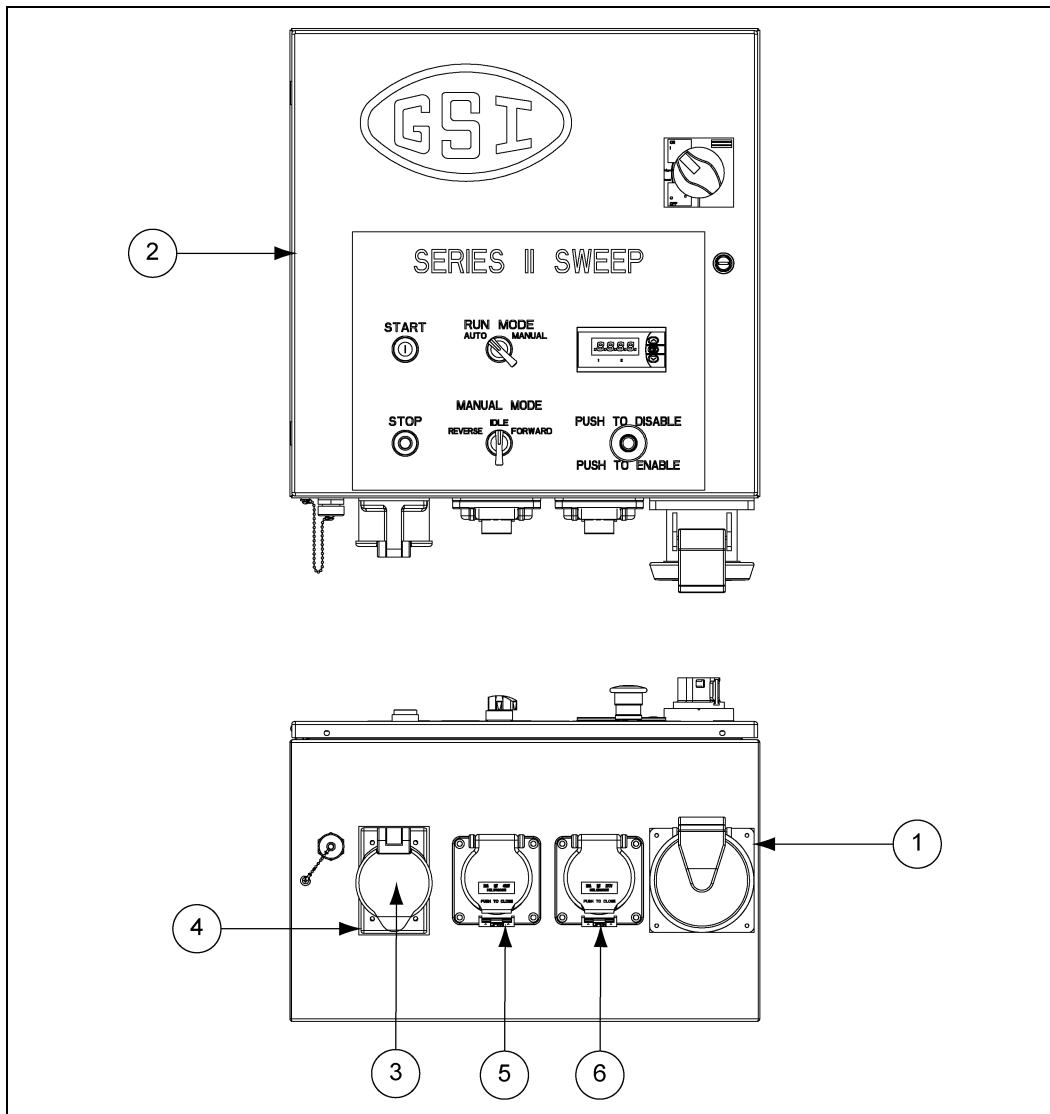

Quick Detach Control Panel Receptacles Parts List

Ref #	Part #	Description
1	GC11769	Receptacle, Female, 3P4W, 60A, 3 PH, 600V - HBL460R5W
2	S2PFA	Series II Sweep Control Package - 08-32A:3-12A, Non-575V
2	S2PFB	Series II Sweep Control Package - 30-40A:3-12A, Non-575V
2	S2PFC	Series II Sweep Control Package - 08-32A:3-12A, 575V Only
3	GC03666	Receptacle, 3P4W, 50A, 3 PH, 480V - CS8169
4	GC03667	Cover, 50A Receptacles, FS/FD Mount, 1 Gang - HBL7774WO
5	GC03669	Receptacle, 3P4W, 20A, 3 PH, 480V, L16-20R - HBL2430SW
6	GC06954	Receptacle, 2P3W, 20A, 277V, L7-20R - HBL2330SW

Quick Detach Control Panel Package (GK80112)

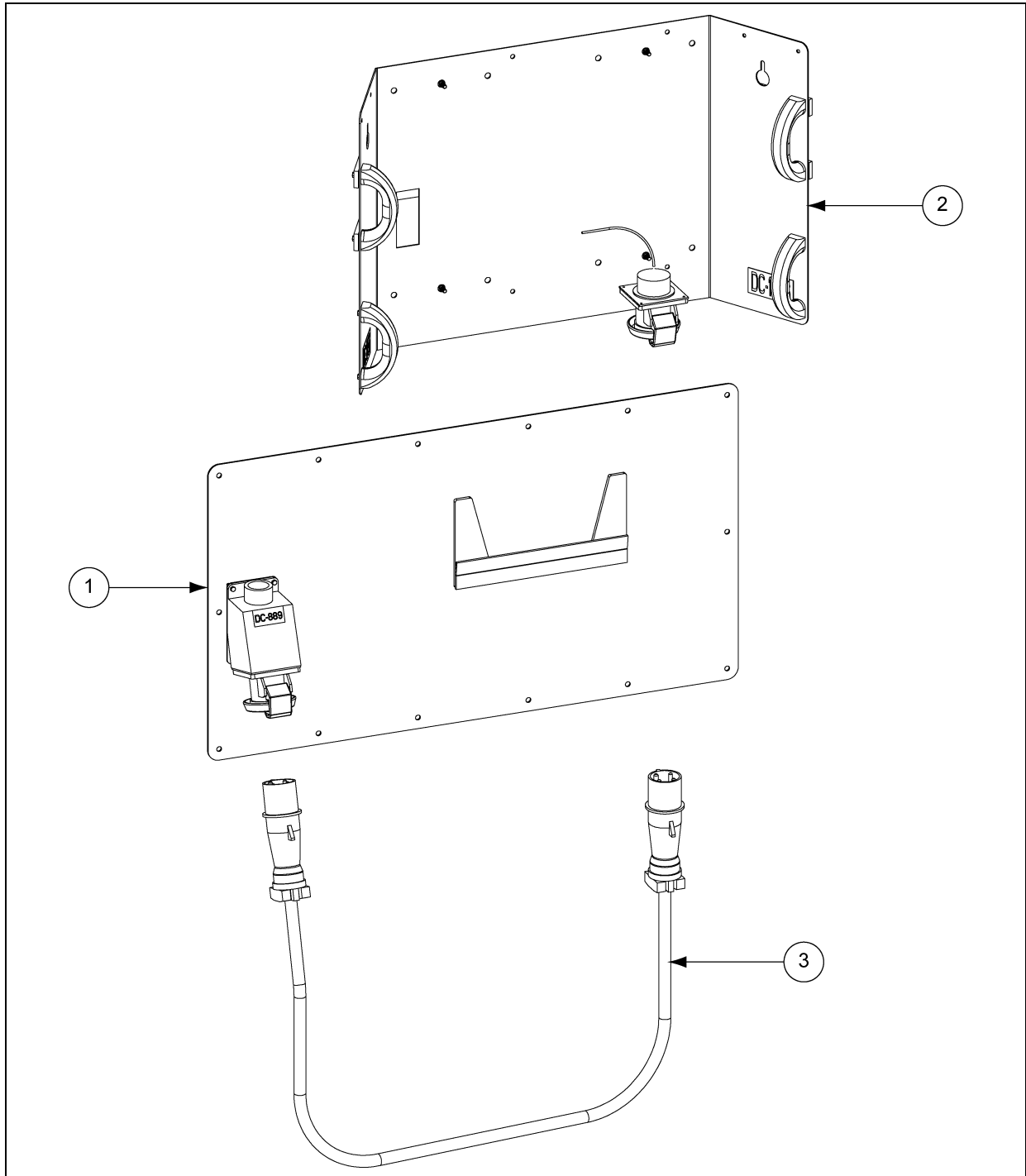

Quick Detach Control Panel Package (GK80112) Parts List

Ref #	Part #	Description
1	GK80110	Lift Base Dock Assembly
2	GK80108	Lift Base Panel Assembly
3	GK80111	Drop Cord Assembly

Lift Base Panel Assembly (GK80108)

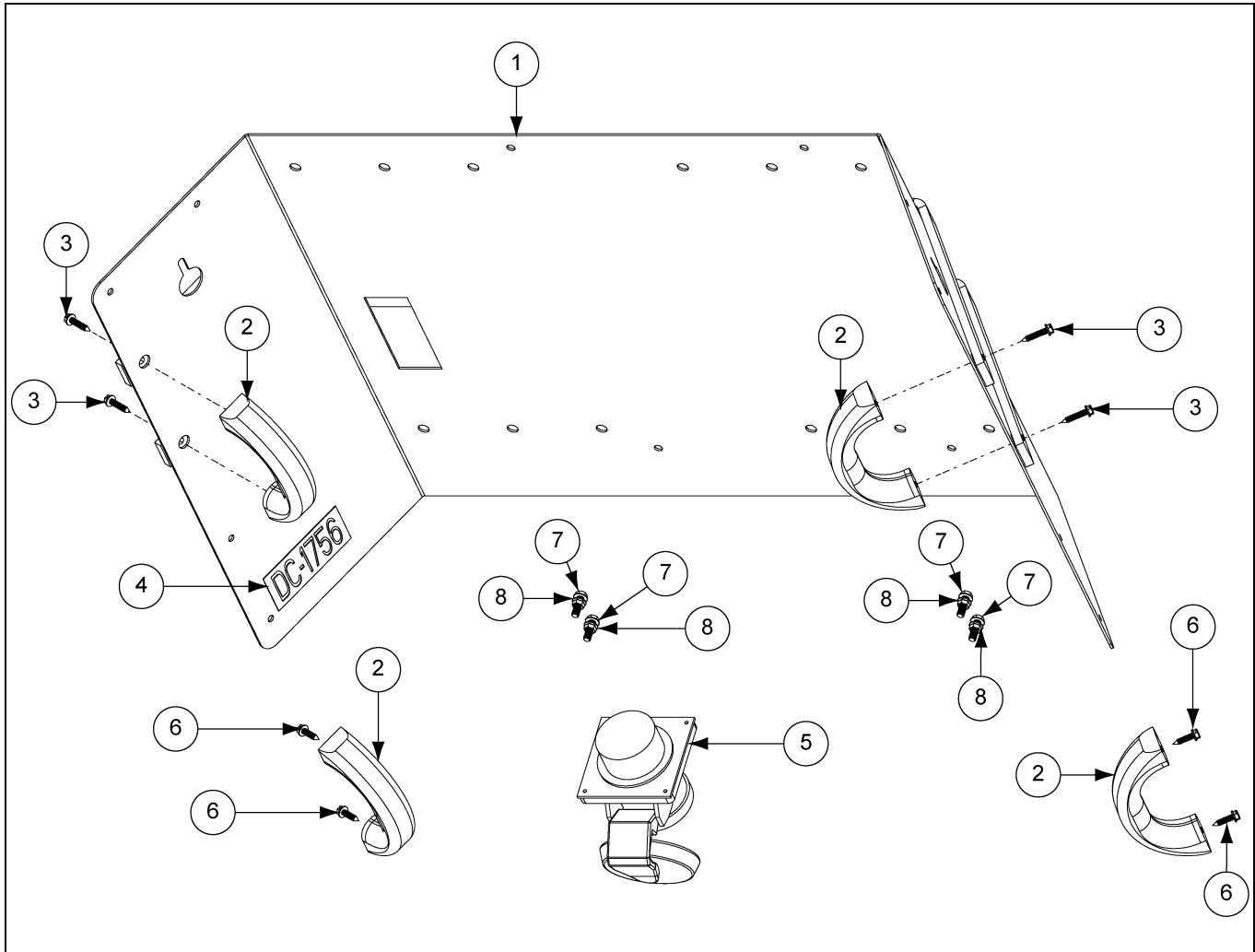

Lift Base Panel Assembly (GK80108) Parts List

Ref #	Part #	Description
1	GK80106	Lift Base Panel Welded Assembly
2	F-7050	Plastic Handle
3	S-9315	Screw, SMSAB 1/4" x 1-1/4" HWHS ZN
4	DC-1756	Decal, Warning, Lifting Hazard
5	GC11769	Receptacle, Female, 3P4W, 60A, 3 PH, 600V - HBL460R5W
6	S-8166	Screw, SMSAB 1/4" x 1" HWH ZN
7	S-7447	5/16"-18 x 1" Serrated Flange Bolt Stainless Steel
8	S-8452	5/16"-18 Serrated Flange Nut Waxed Stainless Steel
N/S	GC10224	Wire, 6 Gauge x 3' Stranded - Black
N/S	GC10225	Wire, 6 Gauge x 3' Stranded THHN - Green

Lift Base Dock Assembly (GK80110)

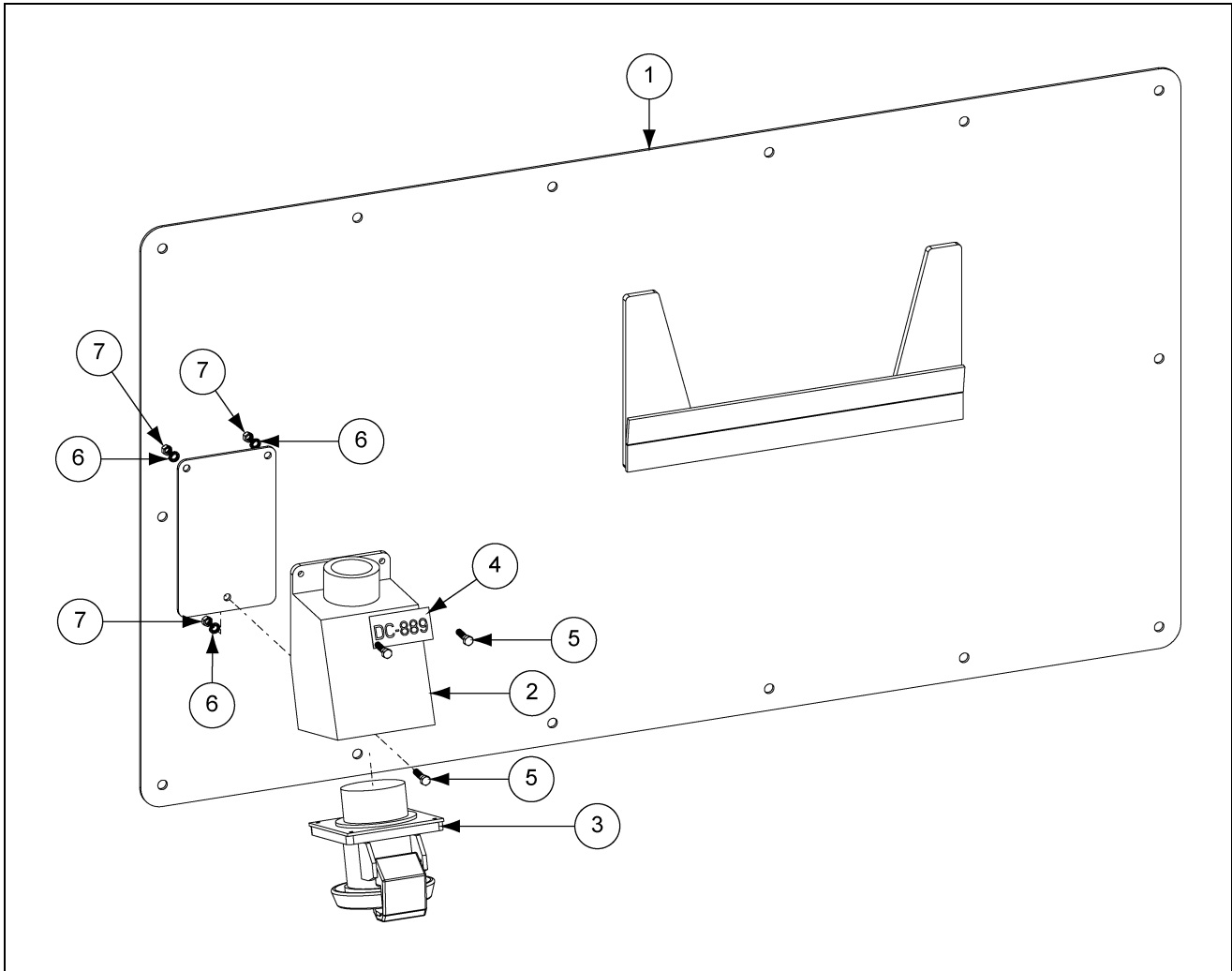

Lift Base Dock Assembly (GK80110) Parts List

Ref #	Part #	Description
1	GC10103	S2S2 Fixed Base Weldment - Kid Control Box
2	GC10071	Box, S2S2 Electrical Back BB602W 60A with 1-1/2" Hub Hubell
3	GC11769	Receptacle, Female, 3P4W, 60A, 3 PH, 600V - HBL460R5W
4	DC-889	Decal, Danger, High Voltage
5	S-6998	Bolt, HHCS 1/4"-20 x 1" ZN Grade 5
6	S-2041	Split Lock Washer 1/4" ZN
7	S-1120	Hex Nut 1/4"-20 ZN Grade 5

Drop Cord Assembly (GK80111)

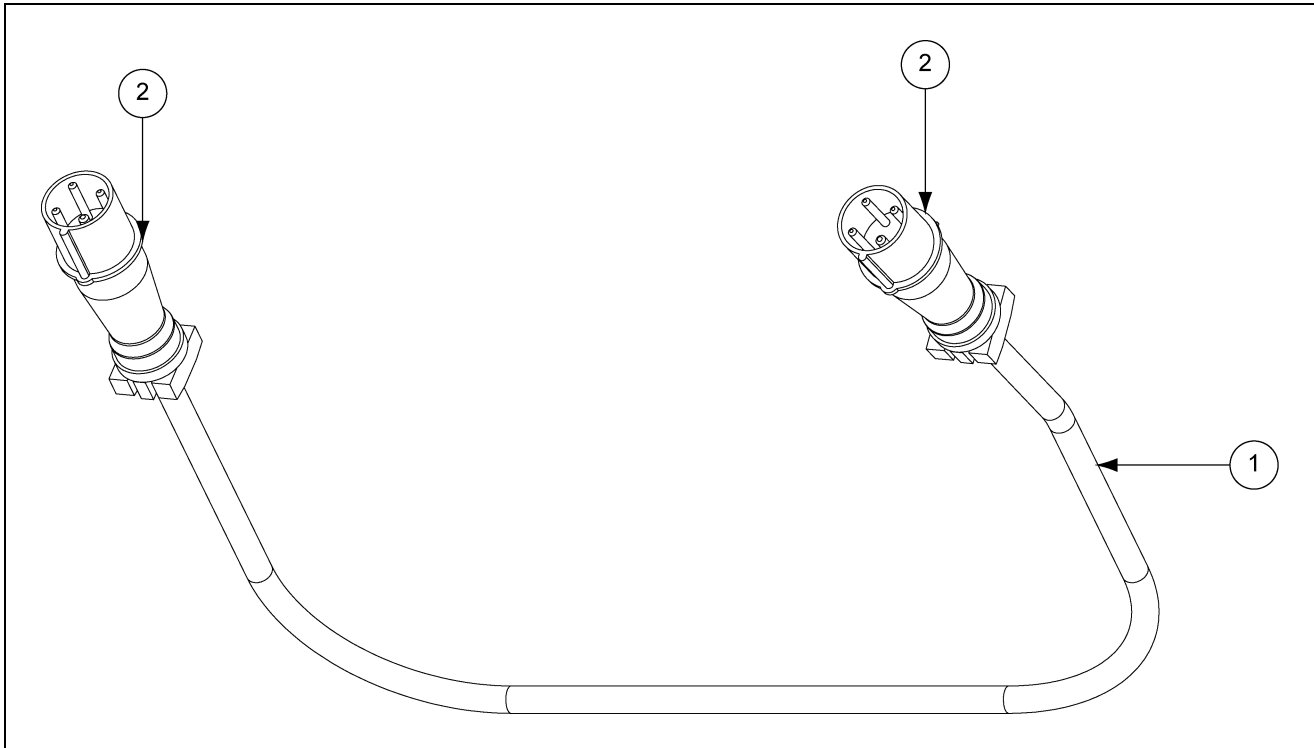

Drop Cord Assembly (GK80111) Parts List

Ref #	Part #	Description
1	GC10078	S2S2 Electrical Cable for Drop Cord
2	GC11770	Plug, Male, 3PW4, 60A, 3 PH, 600V - HBL460P5W

NOTES

GSI Group, LLC Limited Warranty

The GSI Group, LLC ("GSI") warrants products which it manufactures to be free of defects in materials and workmanship under normal usage and conditions for a period of 12 months after sale to the original end-user or if a foreign sale, 14 months from arrival at port of discharge, whichever is earlier. The end-user's sole remedy (and GSI's only obligation) is to repair or replace, at GSI's option and expense, products that in GSI's judgment, contain a material defect in materials or workmanship. Expenses incurred by or on behalf of the end-user without prior written authorization from the GSI Warranty Group shall be the sole responsibility of the end-user.

Warranty Extensions:

The Limited Warranty period is extended for the following products:

	Product	Warranty Period	
AP Fans and Flooring	Performer Series Direct Drive Fan Motor	3 Years	* Warranty prorated from list price: 0 to 3 years - no cost to end-user 3 to 5 years - end-user pays 25% 5 to 7 years - end-user pays 50% 7 to 10 years - end-user pays 75%
	All Fiberglass Housings	Lifetime	
	All Fiberglass Propellers	Lifetime	
Cumberland Feeding/Watering Systems	Feeder System Pan Assemblies	5 Years **	** Warranty prorated from list price: 0 to 3 years - no cost to end-user 3 to 5 years - end-user pays 50%
	Feed Tubes (1-3/4" and 2.00")	10 Years *	
	Centerless Augers	10 Years *	
	Watering Nipples	10 Years *	
Grain Systems	Grain Bin Structural Design	5 Years	† Motors, burner components and moving parts not included. Portable dryer screens included. Tower dryer screens not included.
Grain Systems Farm Fans Zimmerman	Portable and Tower Dryers	2 Years	
	Portable and Tower Dryer Frames and Internal Infrastructure †	5 Years	

GSI further warrants that the portable and tower dryer frame and basket, excluding all auger and auger drive components, shall be free from defects in materials for a period of time beginning on the twelfth (12th) month from the date of purchase and continuing until the sixtieth (60th) month from the date of purchase (extended warranty period). During the extended warranty period, GSI will replace the frame or basket components that prove to be defective under normal conditions of use without charge, excluding the labor, transportation, and/or shipping costs incurred in the performance of this extended warranty.

Conditions and Limitations:

THERE ARE NO WARRANTIES THAT EXTEND BEYOND THE LIMITED WARRANTY DESCRIPTION SET FORTH ABOVE. SPECIFICALLY, GSI MAKES NO FURTHER WARRANTY OF ANY KIND, EXPRESS OR IMPLIED, INCLUDING, WITHOUT LIMITATION, WARRANTIES OF MERCHANTABILITY OR FITNESS FOR A PARTICULAR PURPOSE OR USE IN CONNECTION WITH: (I) PRODUCT MANUFACTURED OR SOLD BY GSI OR (II) ANY ADVICE, INSTRUCTION, RECOMMENDATION OR SUGGESTION PROVIDED BY AN AGENT, REPRESENTATIVE OR EMPLOYEE OF GSI REGARDING OR RELATED TO THE CONFIGURATION, INSTALLATION, LAYOUT, SUITABILITY FOR A PARTICULAR PURPOSE, OR DESIGN OF SUCH PRODUCTS.

GSI shall not be liable for any direct, indirect, incidental or consequential damages, including, without limitation, loss of anticipated profits or benefits. The sole and exclusive remedy is set forth in the Limited Warranty, which shall not exceed the amount paid for the product purchased. This warranty is not transferable and applies only to the original end-user. GSI shall have no obligation or responsibility for any representations or warranties made by or on behalf of any dealer, agent or distributor.

GSI assumes no responsibility for claims resulting from construction defects or unauthorized modifications to products which it manufactured. Modifications to products not specifically delineated in the manual accompanying the equipment at initial sale will void the Limited Warranty.

This Limited Warranty shall not extend to products or parts which have been damaged by negligent use, misuse, alteration, accident or which have been improperly/inadequately maintained. This Limited Warranty extends solely to products manufactured by GSI.

Prior to installation, the end-user has the responsibility to comply with federal, state and local codes which apply to the location and installation of products manufactured or sold by GSI.

This equipment shall be installed in accordance with the current installation codes and applicable regulations which should be carefully followed in all cases. Authorities having jurisdiction should be consulted before installations are made.

G S I G R O U P



GSI Group
1004 E. Illinois St.
Assumption, IL 62510-0020
Phone: 1-217-226-4421
Fax: 1-217-226-4420
www.gsiag.com