

Direct Gear Drive Bin Sweep Auger (with Roller Wells)

Assembly and Operation Manual

PNEG-1421

Date: 10-22-07

GSI GROUP



PNEG-1421

This manual is valid for the sweep catalog numbers in the table below:

Bin Diameter	6" DGD Sweep	8" DGD Sweep	10" DGD Sweep
15'	GPS61503	GPS81503	-
18'	GPS61803	GPS81803	-
21'	GPS62103	GPS82103	-
24'	GPS62403	GPS82403	GPS10242
27'	GPS62703	GPS82703	GPS10272
30'	GPS63003	GPS83003	GPS10302
33'	GPS63303	GPS83303	GPS10332
36'	GPS63603	GPS83603	GPS10362
39'	-	GPS83903	GPS10392
42'	-	GPS84203	GPS10422
48'	-	GPS84803	GPS10482

Contents

Chapter 1 Introduction	5
Chapter 2 Safety	6
Safety Guidelines	6
Safety Instructions	7
Operator Qualifications	10
Chapter 3 Safety Decals	11
Chapter 4 Installation	13
Power Sweep in Bins with Concrete Floors	13
Power Sweeps in Bins with Raised Metal Floors	14
Intermediate Well Installation	15
Unload Tube Installation	16
Install Bin Flange	20
Center Well Slide Gate Assembly	22
Control Lever Installation (6" Systems)	23
Rack and Pinion Installation (8" and 10" Systems)	24
Clutch Control Installation	26
Installing the Unload Tube Flight	28
Install the Sweep Flighting	29
Sweep Wheel Installation	34
Chapter 5 Operation	35
Power Recommendations	35
Before Filling the Bin	36
Perform Pre-Start Checks	37
Operation	38
Engaging the Clutch for Bin Sweep	41
Final Clean-Out	42
Chapter 6 Shut Down	43
Normal Shut Down	43
Emergency Shut Down	43
Storage Preparation	43
Chapter 7 Maintenance	44
Maintaining the Auger	44
Chapter 8 Troubleshooting	45
Chapter 9 Parts List	46
6" Well Gate Control Parts	47
8" and 10" Rack and Pinion	48
6" Intermediate Well Parts	50
8" Intermediate Well Parts	52
10" Intermediate Well Parts	54
Center Well Parts	56
6" Flight and Shield Parts	58
8" and 10" Flight and Shield Parts	60
Reduction Wheel Parts	62
6" Bin Flange Parts	64
8" Bin Flange Parts	65
10" Bin Flange Parts	66
Chapter 10 Warranty	69



Replace missing guards and shields
FREE OF CHARGE!

GSI equipment is built to provide many years of dependable service to our customers through durable craftsmanship.

One of the most important aspects of GSI engineering is **SAFETY 1st** design throughout all product lines. At GSI - Safety is NO ACCIDENT!

That is why GSI is implementing its **SAFETY 1st** program. Should you ever need guards, shields, safety decals, or owner/operator manuals, simply contact GSI, and we will supply you with them **FREE OF CHARGE!**

While it is our main goal for GSI to be the world leader in auger manufacturing, it is always our first priority to keep our customers safe.

If you need any of the above listed safety items or have safety questions, please contact GSI:

GSI Group
PO Box 20
1004 E. Illinois St.
Assumption, IL 62510
Ph: 217-226-4421

READ THIS MANUAL carefully to learn how to properly use and install equipment. Failure to do so could result in personal injury or equipment damage.

INSPECT the shipment immediately upon arrival. The customer is responsible for ensuring that all quantities are correct. The customer should report and note any damage or shortage on the bill of lading to justify their claim to the transport company.

THIS MANUAL SHOULD BE CONSIDERED a permanent part of your equipment and should be easily accessible when needed.

This warranty provides you the assurance that the company will back its products when defects appear within the warranty period. In some circumstances, the company also provides field improvements, often without charge to the customer, even if the product is out of warranty. Should the equipment be abused, or modified to change its performance beyond the factory specifications, the warranty will become void and field improvements may be denied.

Safety Guidelines

This manual contains information that is important for you, the owner/operator, to know and understand. This information relates to protecting **personal safety** and **preventing equipment problems**. It is the responsibility of the owner/operator to inform anyone operating or working in the area of this equipment of these safety guidelines. To help you recognize this information, we use the symbols that are defined below. Please read the manual and pay attention to these sections. Failure to read this manual and its safety instructions is a misuse of the equipment and may lead to serious injury or death.



This is the safety alert symbol. It is used to alert you to potential personal injury hazards. Obey all safety messages that follow this symbol to avoid possible injury or death.



DANGER indicates an imminently hazardous situation which, if not avoided, will result in death or serious injury.



WARNING indicates a potentially hazardous situation which, if not avoided, could result in death or serious injury.



CAUTION indicates a potentially hazardous situation which, if not avoided, may result in minor or moderate injury.



CAUTION used without the safety alert symbol indicates a potentially hazardous situation which, if not avoided, may result in property damage.



NOTE indicates information about the equipment that you should pay special attention.

Safety Instructions

Our foremost concern is your safety and the safety of others associated with this equipment. We want to keep you as a customer. This manual is to help you understand safe operating procedures and some problems which may be encountered by the operator and other personnel.

As owner and/or operator, it is your responsibility to know what requirements, hazards and precautions exist, and to inform all personnel associated with the equipment or in the area. Safety precautions may be required from the personnel. Avoid any alterations to the equipment. Such alterations may produce a very dangerous situation where SERIOUS INJURY or DEATH may occur.

This equipment shall be installed in accordance with the current installation codes and applicable regulations which should be carefully followed in all cases. Authorities having jurisdiction should be consulted before installations are made.

Follow Safety Instructions

Carefully read all safety messages in this manual and safety signs on your machine. Keep signs in good condition. Replace missing or damaged safety signs. Be sure new equipment components and repair parts include the current safety signs. Replacement safety signs are available from the manufacturer.

Learn how to operate the machine and how to use controls properly. Do not let anyone operate without instruction.

Keep your machinery in proper working condition. Unauthorized modifications to the machine may impair the function and/or safety and affect machine life.

If you do not understand any part of this manual or need assistance, contact your dealer.

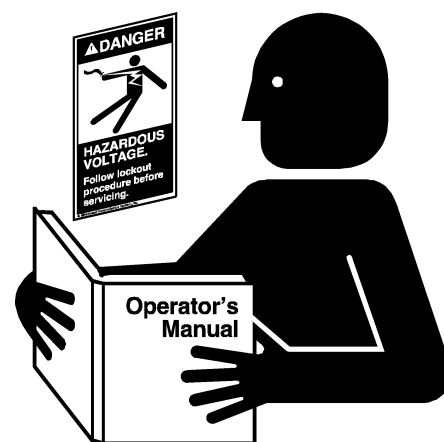

Read and Understand Manual

Install and Operate Electrical Equipment Properly

Electrical controls should be installed by a qualified electrician and must meet the standards set by the National Electrical Code and all local and state codes.

Disconnect and lock out all power sources before installing wires/cables or servicing equipment.



Electric Shock Hazard

Operate Unload Equipment Properly

- Untrained operators subject themselves and others to **SERIOUS INJURY** or **DEATH**. **NEVER** allow untrained personnel to operate this equipment.
- **NEVER** work alone.
- Keep children and other unqualified personnel out of the working area at **ALL** times. Refer to the **Start-Up** section of this manual for diagrams of the work area.
- Make sure **ALL** equipment is locked in position before operating.
- **NEVER** start equipment until **ALL** persons are clear of the work area.
- Keep hands and feet away from the auger intake and other moving parts.
- **NEVER** attempt to assist machinery operation or to remove trash from equipment while in operation
- Be sure all operators are adequately rested and prepared to perform all functions of operating this equipment.
- **NEVER** allow any person intoxicated or under the influence of alcohol or drugs to operate the equipment.
- Make sure someone is nearby who is aware of the proper shut down sequence in the event of an accident or emergency.
- **ALWAYS** think before acting. **NEVER** act impulsively around the equipment.
- **NEVER** allow anyone inside a bin, truck or wagon which is being unloaded by an auger or conveyor. Flowing grain can trap and suffocate in seconds.
- Use ample overhead lighting after sunset to light the work area.
- Keep area around intake free of obstacles such as electrical cords, blocks, etc. that might trip workers.
- **NEVER** drive, stand or walk under the equipment.
- Use caution not to hit the auger when positioning the load.
- **ALWAYS** lock out **ALL** power to the equipment when finished unloading a bin.
- Be aware of pinch points. A pinch point is a narrow area between two surfaces that is likely to trap or catch objects and so is a potential safety hazard.



**Operate Unload
Equipment Safely**

Rotating Flight

Grain augers can kill or dismember.

Keep clear of all augers and never enter the bin unless all power is disconnected and locked out. Failure to do so will result in serious injury or death.



Rotating Flight

Prepare for Emergencies

Be prepared if fire starts.

Keep a first aid kit and fire extinguisher handy.

Keep emergency numbers for doctors, ambulance service, hospital and fire department near your telephone.

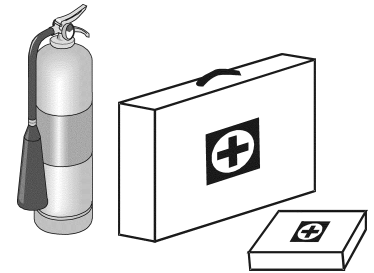

Keep Emergency Equipment Quickly Accessible

Wear Protective Clothing

Wear close fitting clothing and safety equipment appropriate to the job.

Remove all jewelry.

Long hair should be tied up and back.

Safety glasses should be worn at all times to protect eyes from debris.

Wear gloves to protect your hands from sharp edges on plastic or steel parts.

Wear steel toe boots to help protect your feet from falling debris. Tuck in any loose or dangling shoe strings.

A respirator may be needed to prevent breathing potentially toxic fumes and dust.

Wear hard hat to help protect your head.

Eye Protection

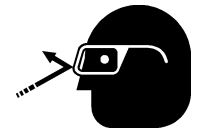

Gloves



Steel Toe Boots



Respirator



Hard Hat



Check components shown below to ensure that the safety decals are in place and in good condition. If a decal cannot be easily read for any reason or has been painted over, replace it immediately. Contact your dealer or the manufacturer to order a replacement decal free of charge.

Decal Part List

Part #	Description	Size
DC-1834	Important - Power Sweep Position	7-3/8" x 2-3/4"
DC-1266	Danger - Bin Well	7-1/2" x 2-1/2"
DC-1384	Danger - Keep Out of Bin	6-1/4" x 1-1/4"
DC-1395	Danger - Rotating Flight	4-1/4" x 6-1/4"

IMPORTANT: BEFORE FILLING BIN CLOSE CENTER WELL AND INTERMEDIATE WELL GATES. POSITION SWEEP AUGER OVER INTERMEDIATE WELLS.

INSTRUCTIONS:

1. BE SURE POWER SWEEP CLUTCH CONTROL IS DISENGAGED AND TIGHTEN SET SCREW.
2. START UNLOADING AUGER. OPEN CENTER WELL GATE.
3. WHEN GRAIN STOPS FLOWING FROM CENTER WELL GATE, OPEN INTERMEDIATE WELLS.
4. WHEN GRAIN STOPS FLOWING FROM INTERMEDIATE WELLS, STOP AUGER. TO ENGAGE POWER SWEEP, ROTATE UNLOADING AUGER SLOWLY UNTIL CLUTCH ENGAGES AND TIGHTEN SET SCREW. START AUGER.

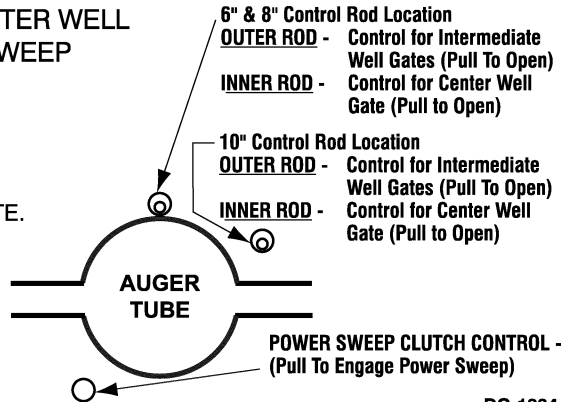

DC-1834

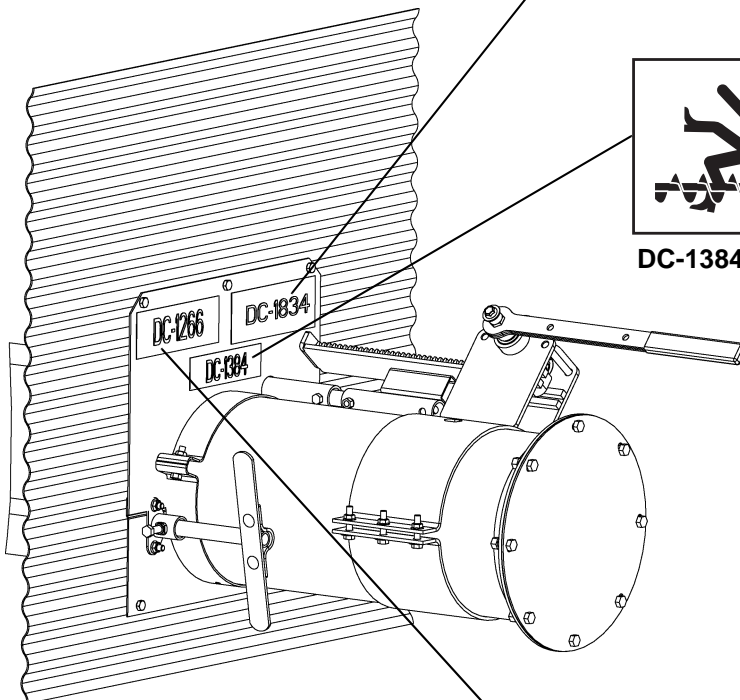

DC-1384



DC-1266

3. Safety Decals

Check components shown below to ensure that the safety decals are in place and in good condition. If a decal cannot be easily read for any reason or has been painted over, replace it immediately. Contact your dealer or the manufacturer to order a replacement decal free of charge.

DANGER: Sign No. DC-1395 was supplied with your bin unloading equipment. This safety sign should be applied to the side of the bin near the bin opening, so it will be viewed by people entering into the bin storage building. Do not cover any safety signs or any other signs that are already there.

NOTE: Please remember, safety signs provide important safety information for people working near bin unloading equipment that is in operation.

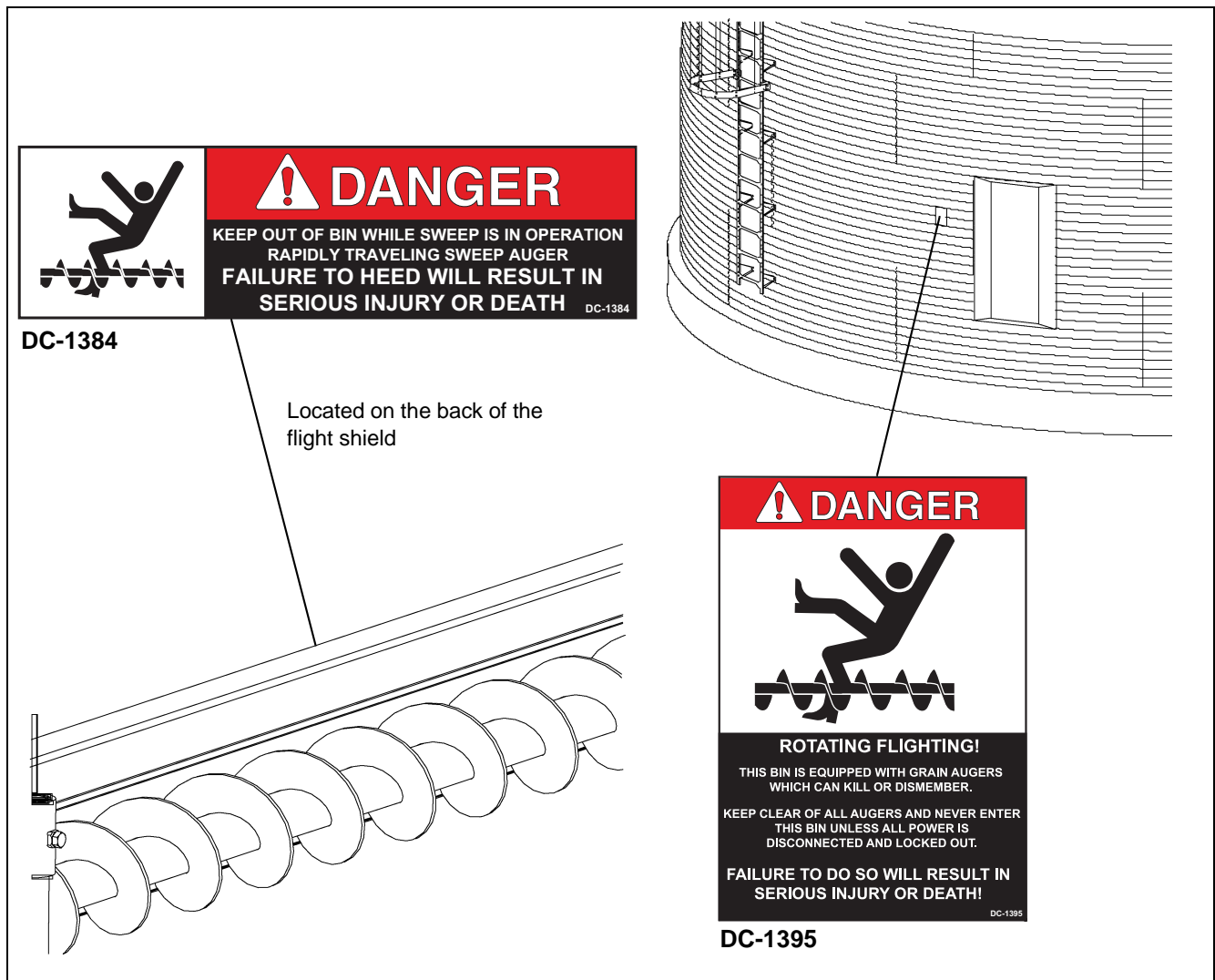

Power Sweep in Bins with Concrete Floors

NOTE: The company does not recommend setting the direct gear drive bin sweep auger unit in concrete. If installing a unit flush with a concrete floor, we recommend that the unit be installed in a preformed trench. Use [Figure 4A](#) below.

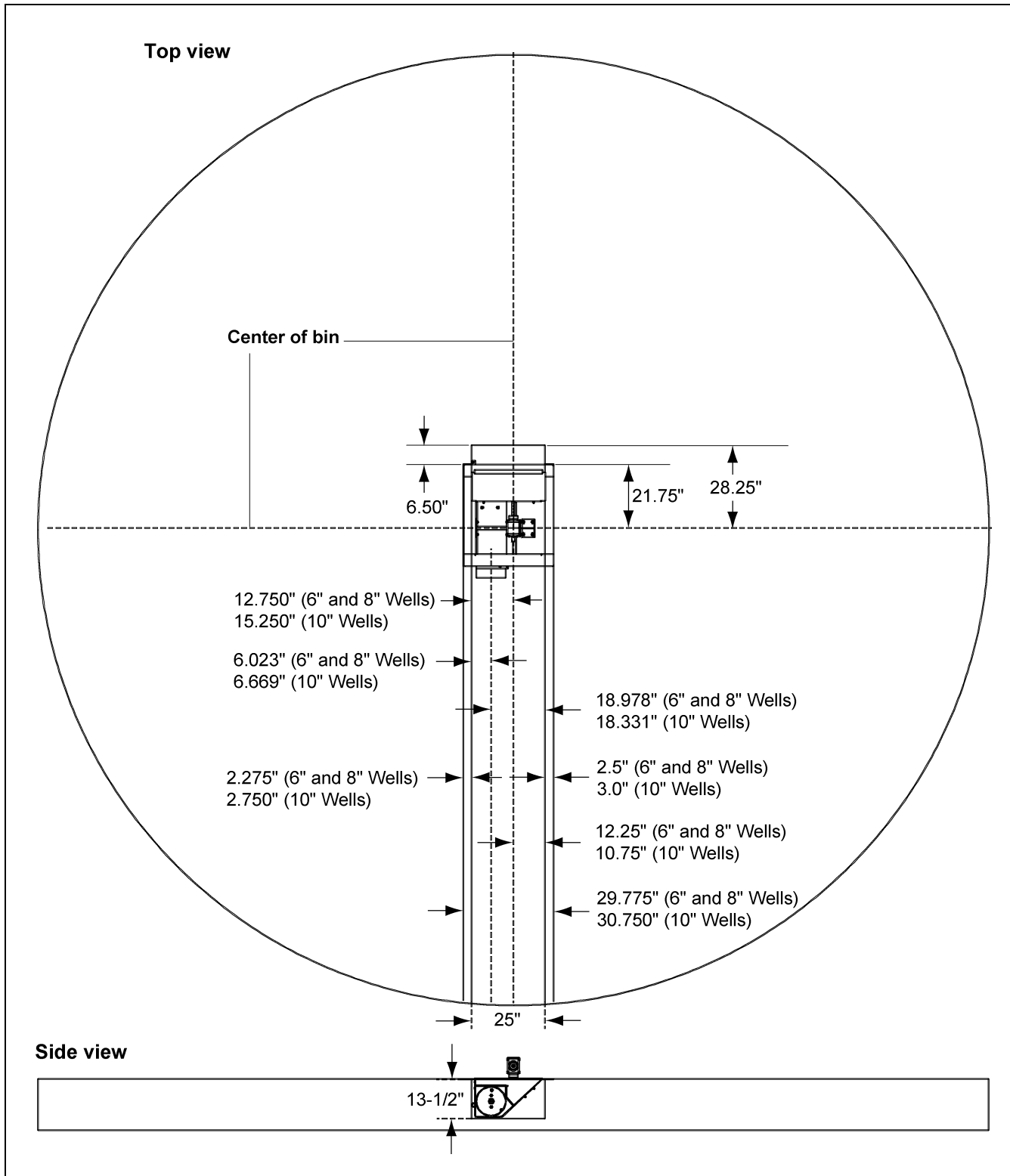

Figure 4A Concrete Trench Layout for 6", 8" and 10" Power Sweeps

4. Installation

Power Sweeps in Bins with Raised Metal Floors

For bins with raised metal floors, it is necessary to cut openings in the floor for the center well and intermediate wells. Make sure the metal floor is high enough above the concrete base so there is space for the wells. It would be convenient to complete assembly of the bin floor as the power sweep is being installed for better access to components under the floor.

1. Locate the center of the bin and make a cut-out in the bin floor for the center well.
See Figure 4B for cut-out size and location of 6" and 8" wells. *See Figure 4C* for 10" wells. Locate the vertical shaft between the gear boxes in the center of the bin. Place suitable supports under the center well to hold it in position.

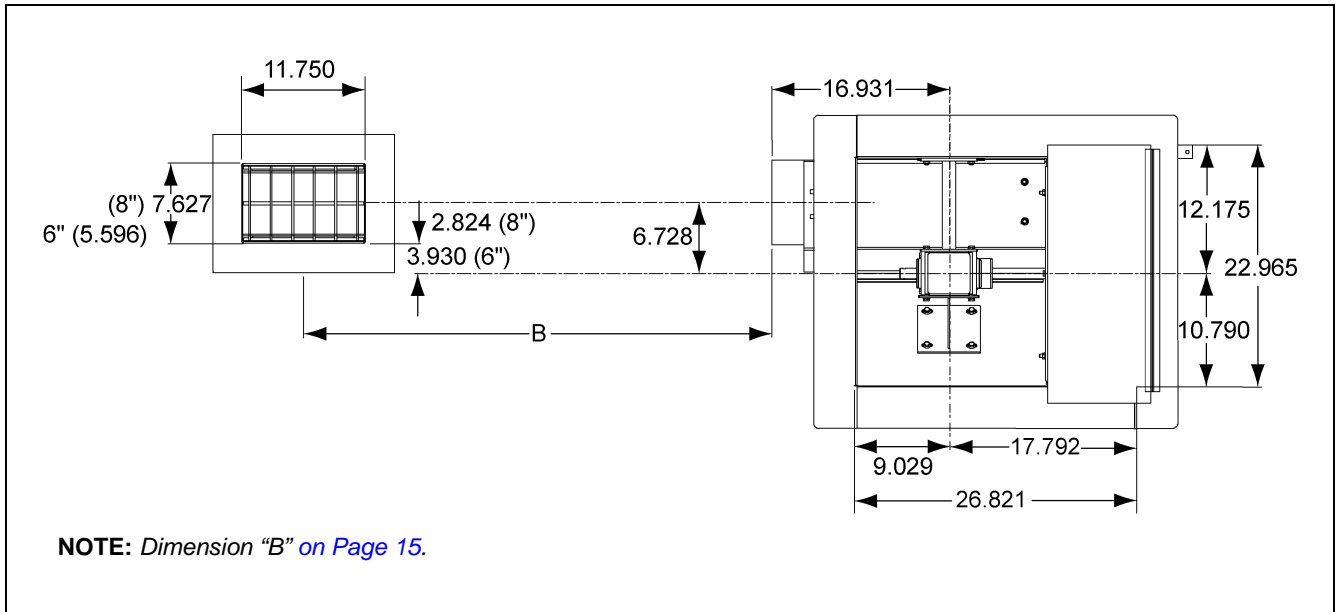

Figure 4B 6" and 8" (15.24 cm 20.32 cm) Center and Intermediate Well(s) Bin Floor Cut-Outs

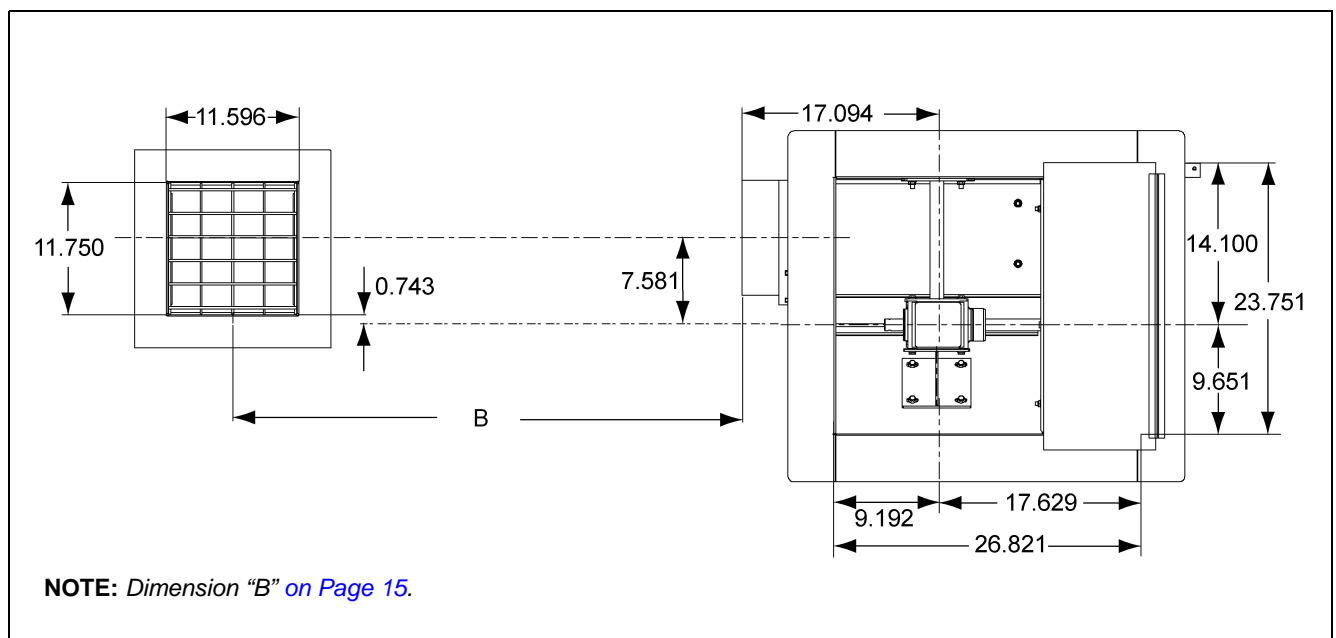

Figure 4C 10" (25.40 cm) Center and Intermediate Well(s) Bin Floor Cut-Outs

Intermediate Well Installation

1. Cut openings in the bin floor for the intermediate wells. *See Figure 4B* and *Figure 4C*. The number of wells depends on bin size. The distances between intermediate wells and the center well should be equal. *See Figure 4D* and *Chart below*.

Bin Size	Number of Intermediate Wells	Distance from Center of Bin to Wall (A)	Distance Between Center Well and First Intermediate Well (B)	Distance Between Wells (C)	Distance from Center of Bin to Angle Ring (D)
15'	1	7' 5-1/2"	39.375"	*	9' 5"
18'	1	8' 11-7/16"	36.75"	*	11' 5"
21'	2	10' 5-5/16"	32.5"	49.75"	12' 5"
24'	2	11' 11-1/4"	38.5"	55.75"	13' 11"
27'	2	13' 5-3/16"	44.5"	61.75"	15' 5"
30'	2	14' 11"	50.5"	67.75"	16' 11"
33'	3	16' 4-15/16"	39.563"	56.813"	18' 11"
36'	3	17' 10-7/8"	42.563"	59.813"	19' 11"
39'	3	19' 4-3/4"	47.063"	64.313"	21' 5"
42'	4	20' 10-11/16"	39"	56.25"	23' 5"
48'	4	23' 10-1/2"	46.2"	63.45"	26' 5"

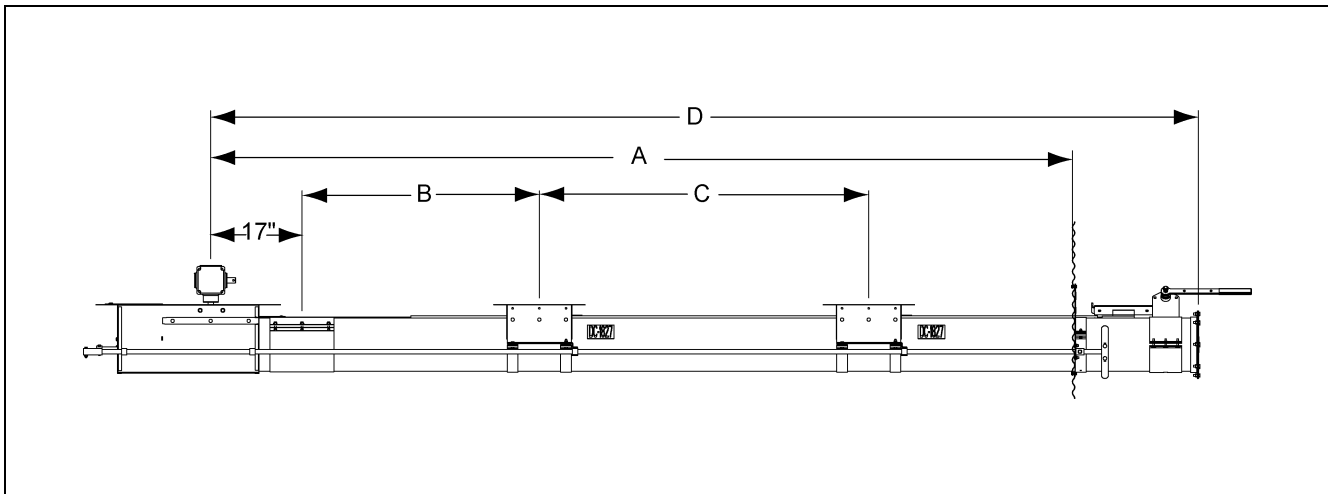

Figure 4D

Unload Tube Installation

1. Cut an opening in the bin wall for the unloading tube to pass through. *See Chart below for hole information. Additional views of the holes can be found in [Figure 4E](#), [Figure 4F](#) and [Figure 4G](#).*

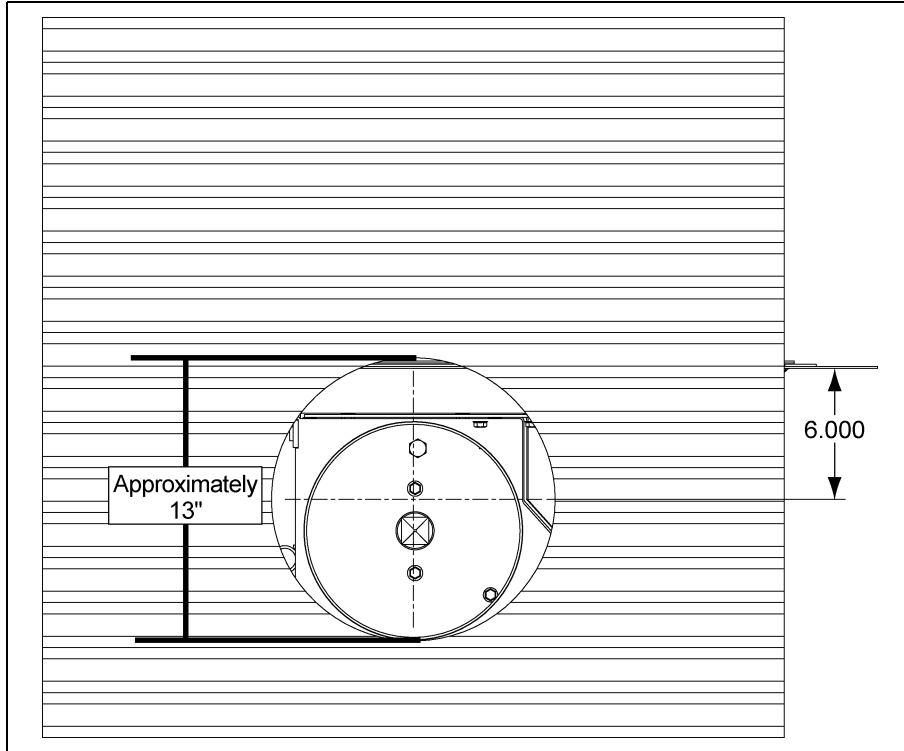

Figure 4E

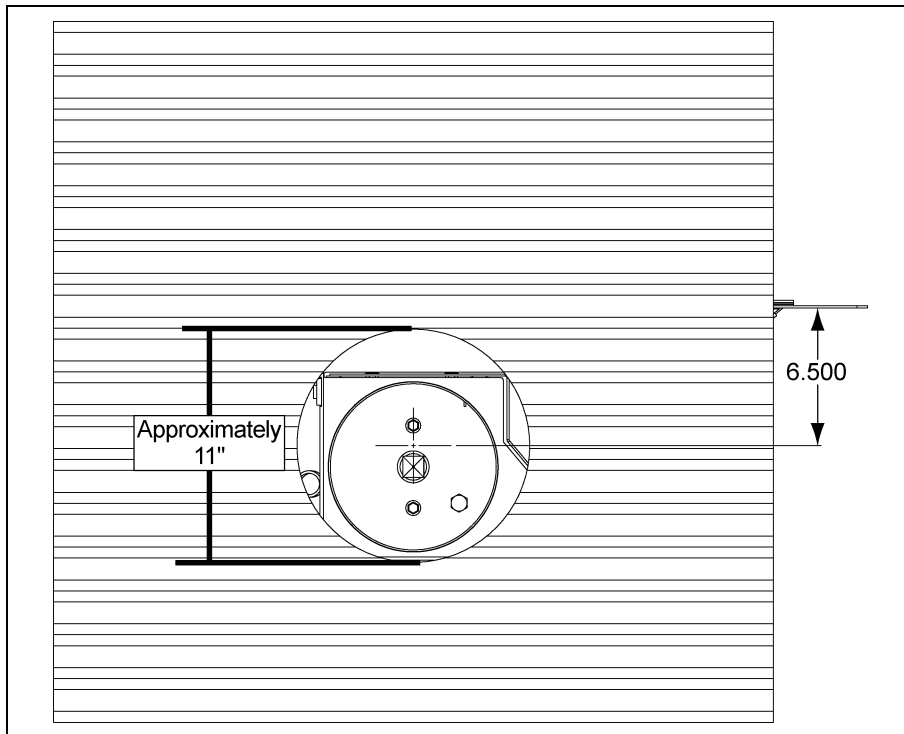

Figure 4F 8" Tube

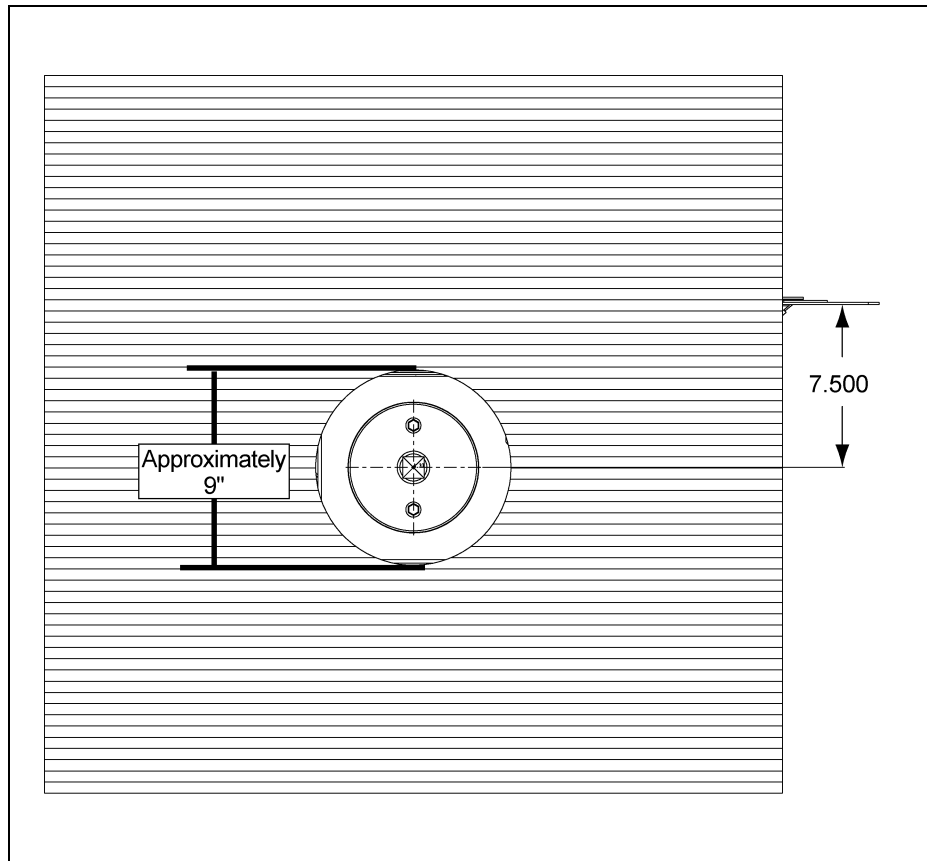

Figure 4G 6" Tube

Tube Size	Hole Size and Location
10"	13" Hole, approximately 6" below the bin floor, inline with the center well tube.
8"	11" Hole, approximately 6-1/5" below the bin floor, inline with the center well tube.
6"	9" Hole, approximately 7-1/2" below the floor, directly inline with the center well tube.

- From inside the bin, insert the angle ring end of the unload tube through the hole in the bin sidewall.

NOTE: Before installing tube, remove flight from inside of tube.

4. Installation

3. Place the connecting band onto the end of the unload tube closest to the center well. *(See Figure 4H.)*

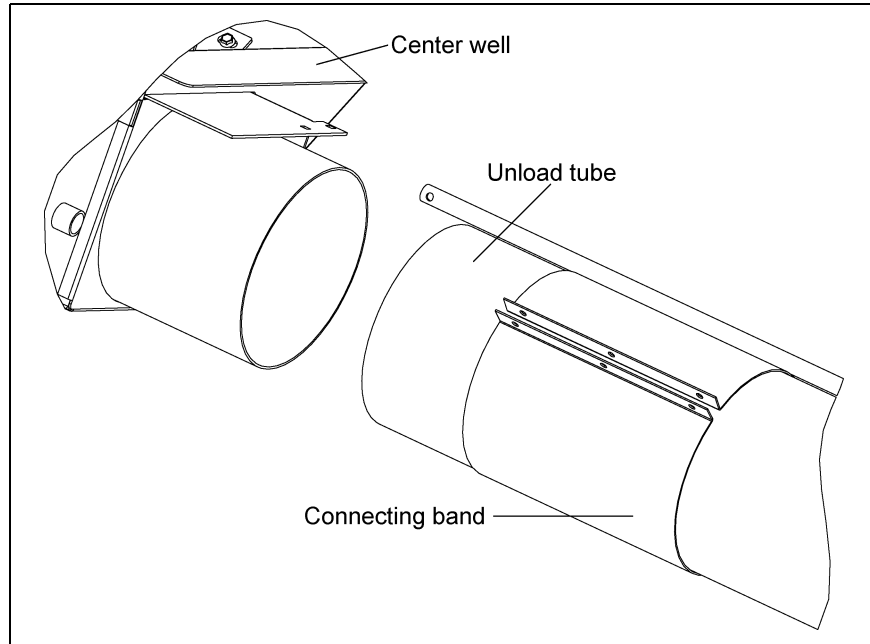

Figure 4H

4. Position the unload tube flush against the center well tube. *(See Figure 4I.)*

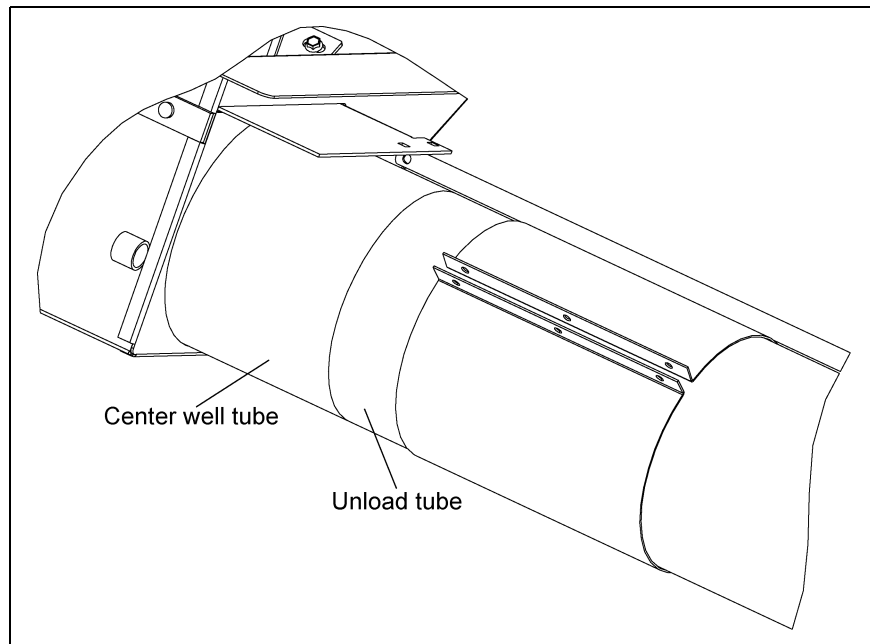

Figure 4I

- Slide the connecting band until it is equally positioned over both the unload tube and the center well tube. Position the connecting band so that it will not interfere with the control rods. (See Figure 4J.)

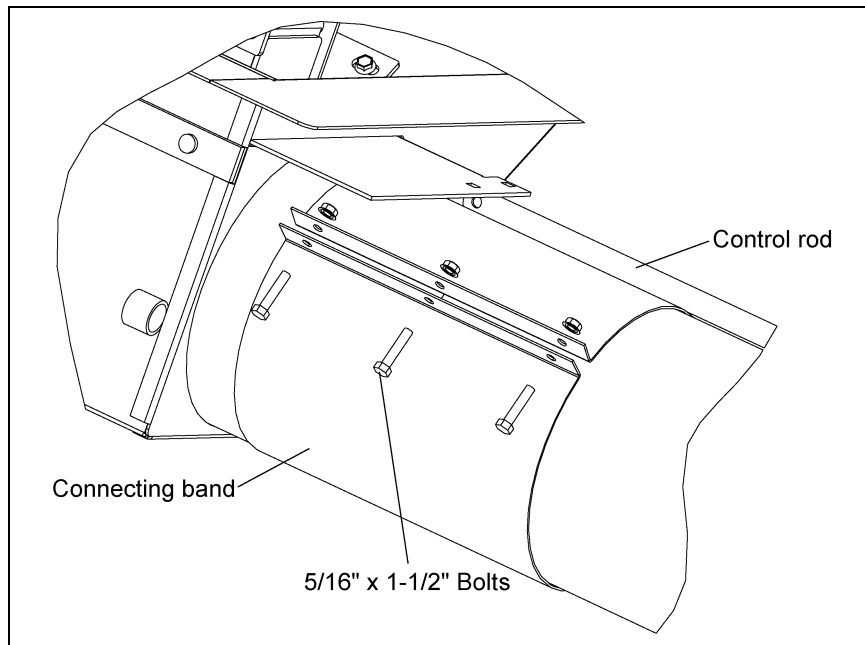

Figure 4J

- Secure the connecting band with three (3) 5/16" x 1-1/2" bolts and serrated flange nuts, making sure the intermediate wells are aligned to the center wells.

Install Bin Flange

1. Attach the upper and lower bin flanges loosely to the auger tube using two (2) 5/16" x 1-1/2" bolts and serrated flange nuts. (See Figure 4K.)

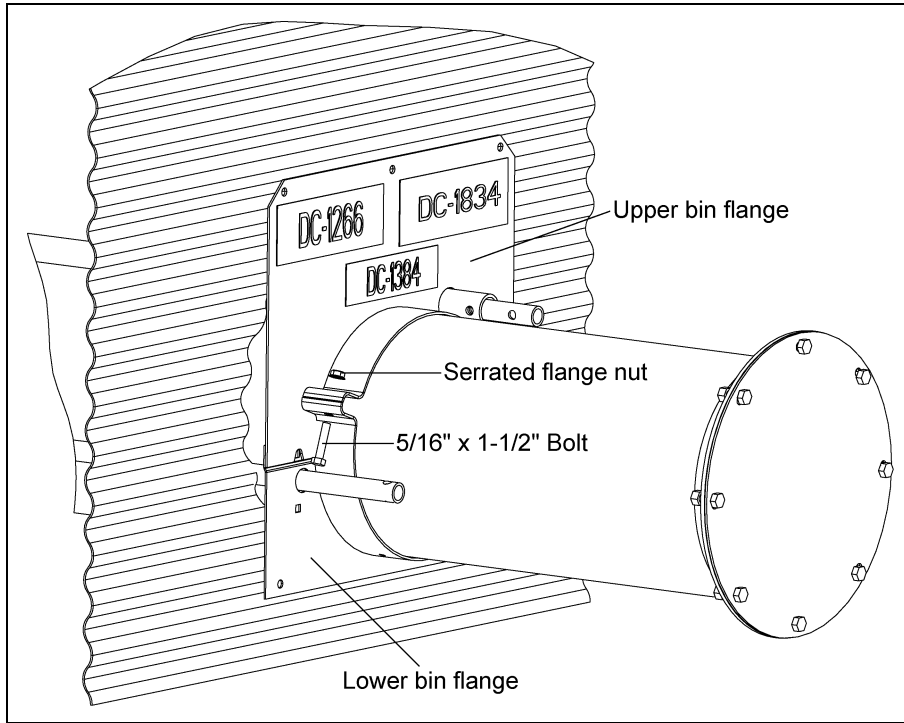

Figure 4K

2. Next, install the clutch lock collar to the lower bin flange using two (2) 5/16" x 3/4" carriage bolts and serrated flange nuts. Install the bolt heads on the backside of the lower bin flange so they will be next to the bin wall when the flanges are attached to the bin. (See Figure 4L.)

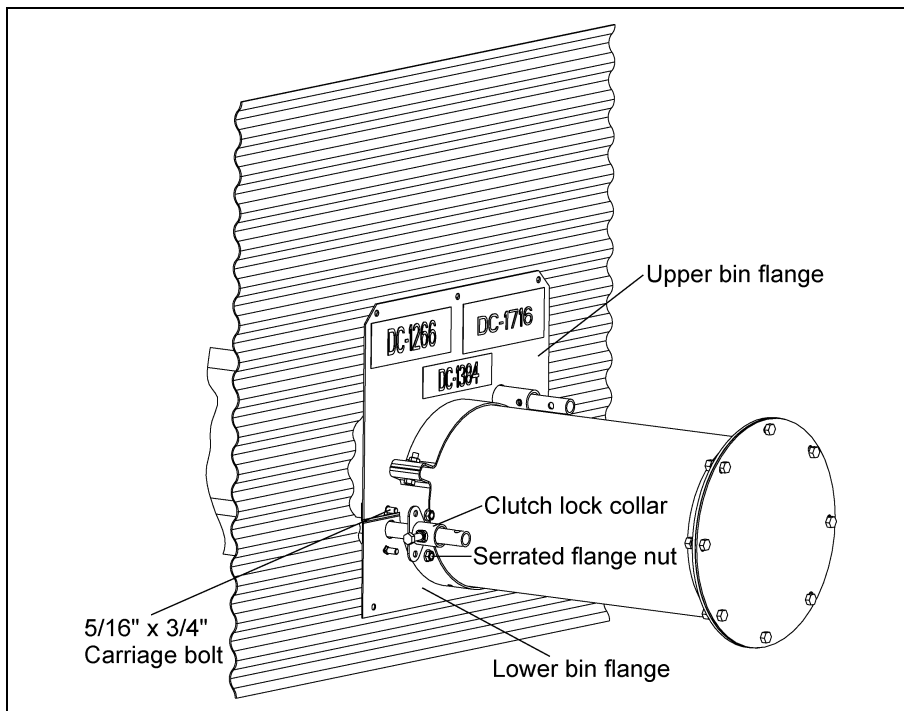

Figure 4L

3. With the flange not yet attached to the bin wall, make sure that the bin wall opening is large enough for the clutch and well control rods to pass through the bin wall.
4. Slide the bin flanges flush up to the bin wall and tighten the bolts connecting the two (2) flanges.
5. Drill into the bin wall through the holes located on the four (4) corners of bin flanges. Fasten the bin flanges to the bin wall using four (4) 5/16" x 3/4" bin wall bolts and serrated flange nuts.
(See Figure 4M.)

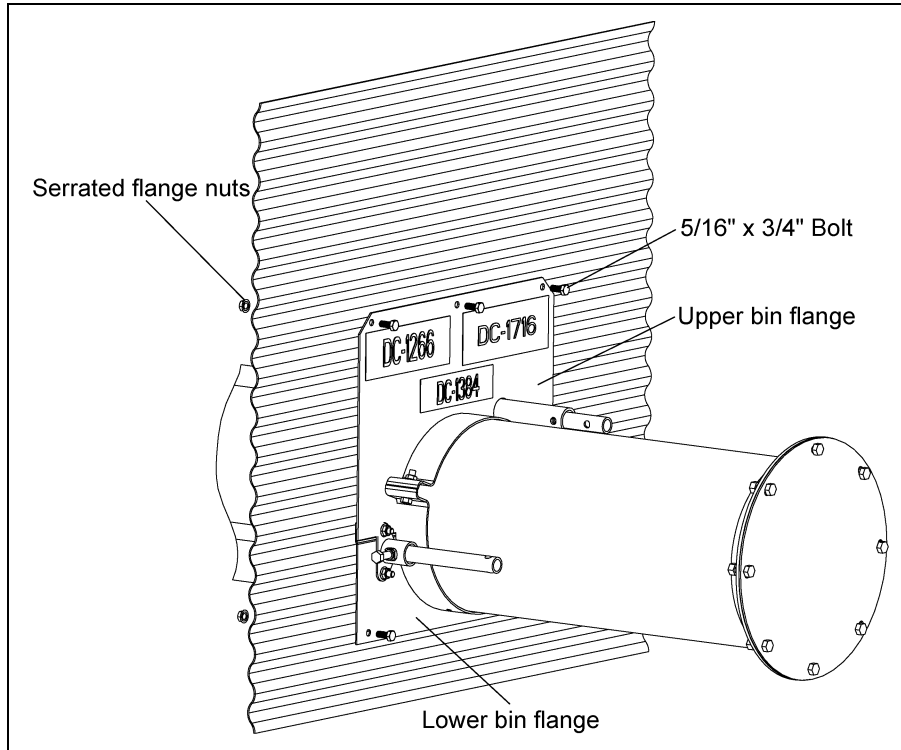

Figure 4M

6. Drill the remaining holes into the bin wall and attach the remaining 5/16" x 3/4" bin wall bolts and serrated flange nuts.

4. Installation

Center Well Slide Gate Assembly

1. Close the center slide gate completely.
2. Align control rod between holes in gate.
3. Attach control gate clamp to control rod by sliding 5/16" x 1-3/4" long roll pin through clamp and control pipe.
4. Fasten clamp to bottom side of control gate by using two (2) 5/16" x 3/4" long carriage bolts and serrated flange nuts. (See Figure 4N.)

NOTE: 6" and 8" rods attach on the TOP side of the center well gate.

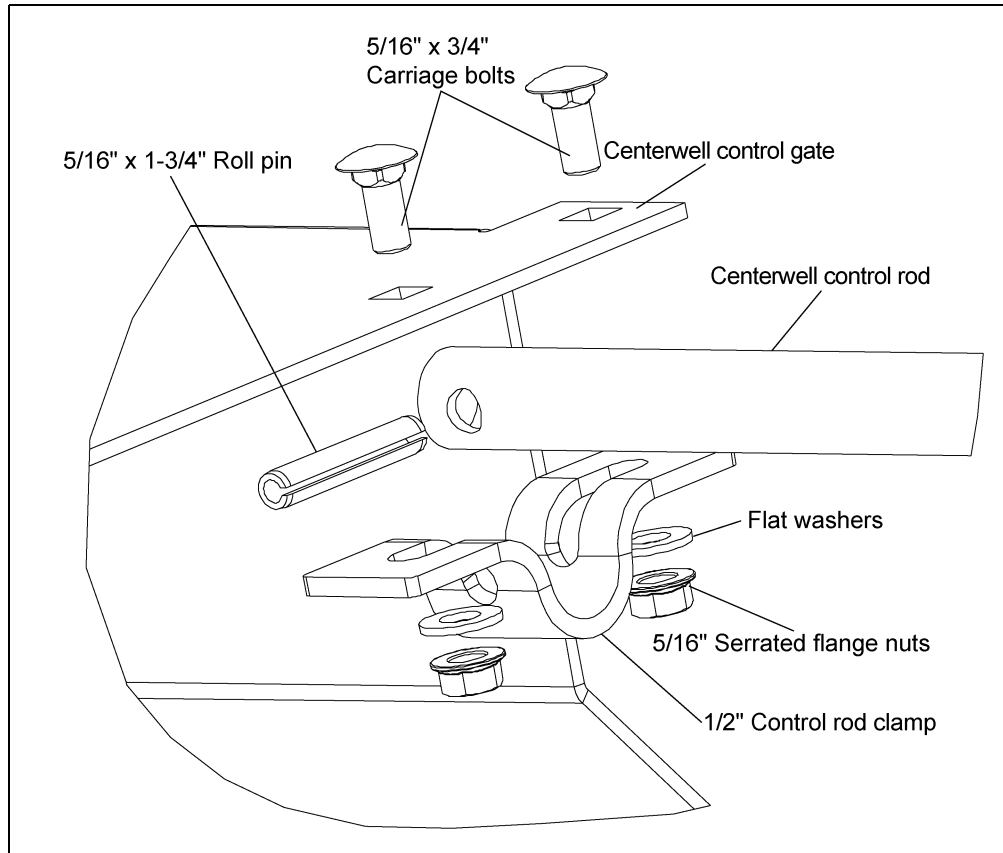

Figure 4N

Control Lever Installation (6" Systems)

1. Close all slide control gates and keep them closed.
2. Attach the control lever by sliding the safety snap-on pin through the lever and both control rods as [Figure 40](#).

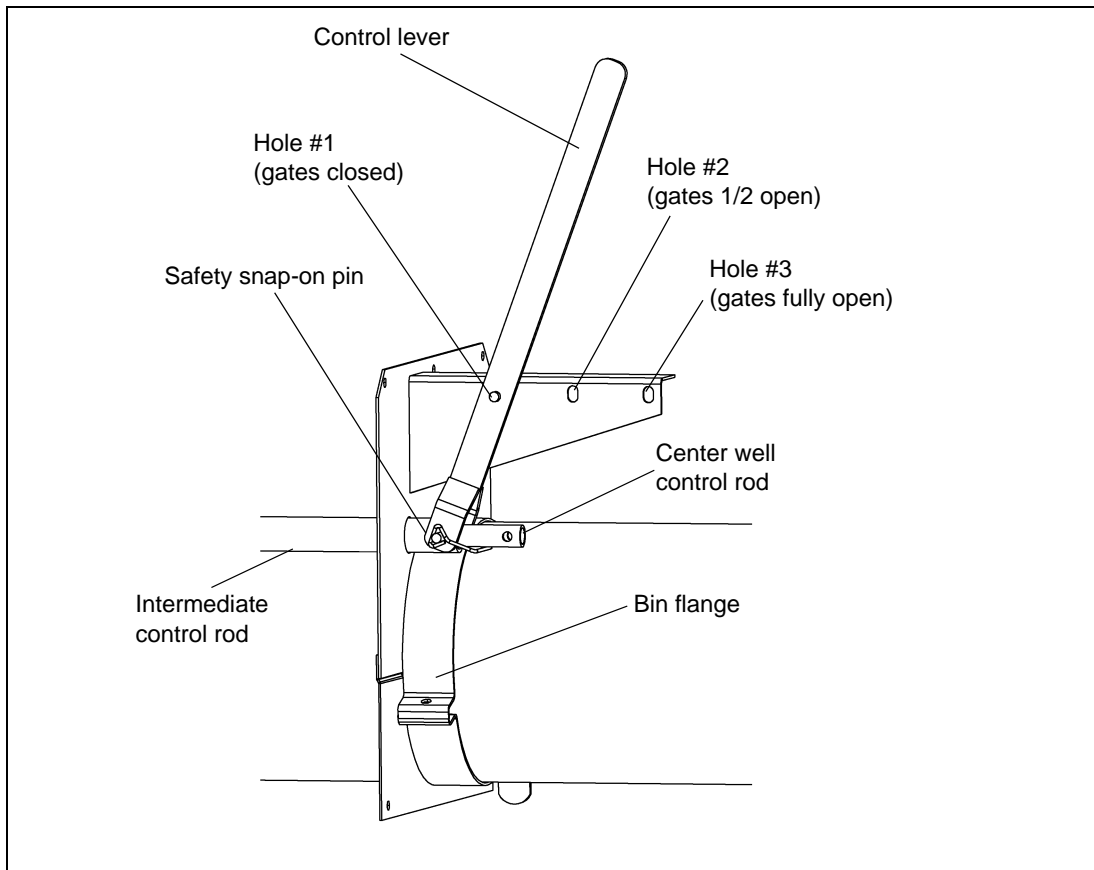

Figure 40 6" Systems

3. Put the control lever in the 1st slot closest to the bin flange. This slot should be used to close the gates.

4. Installation

Rack and Pinion Installation (8" and 10" Systems)

1. Make sure all gates are fully closed.
2. Slip rack and pinion tube over center gate control rod and align holes, making sure rack and pinion is fully extended toward bin wall. (See Figure 4P.)
3. With rack and pinion resting on unload tube, and tube holes aligned, insert one (1) 5/16" x 1-3/4" bolt through the rack and pinion tube and center gate control rod. Fasten together with a nut. (See Figure 4P.)

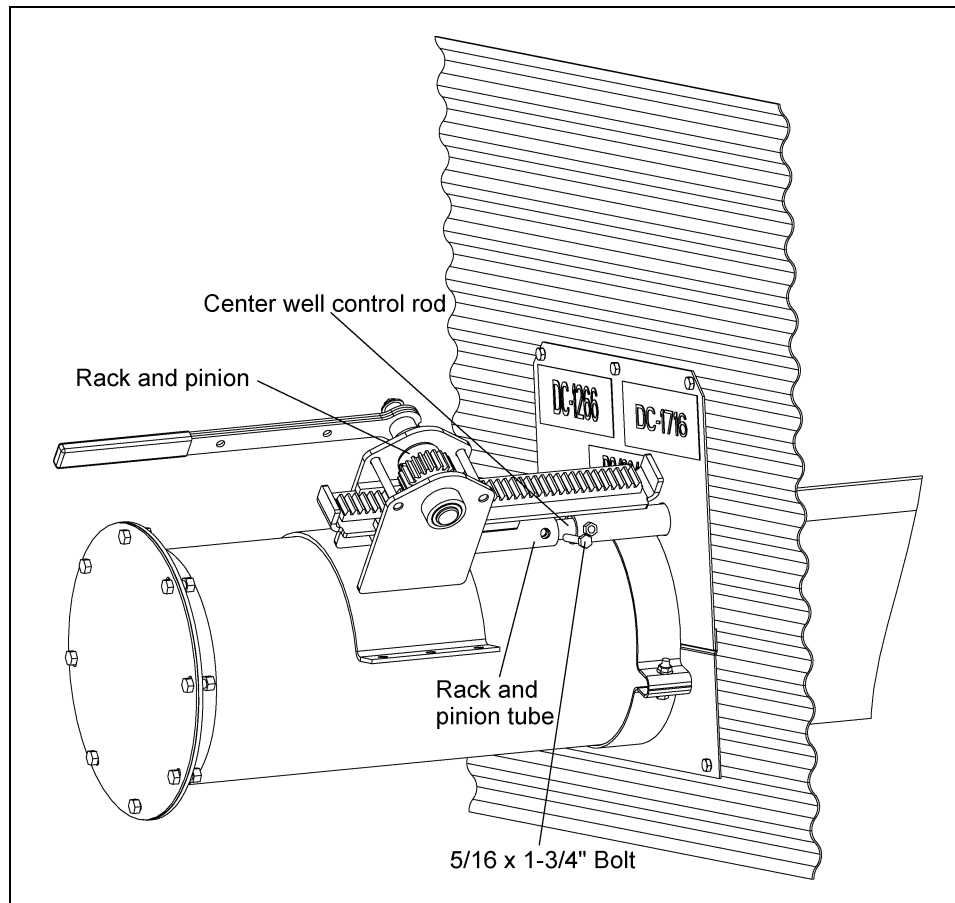

Figure 4P 8" and 10" Systems

- Slide wrench over shaft on rack and pinion, making sure the collar faces the gears. Fasten down with 3/8" flat washer and 3/8" x 3/4" hex bolt. (See Figure 4Q.)

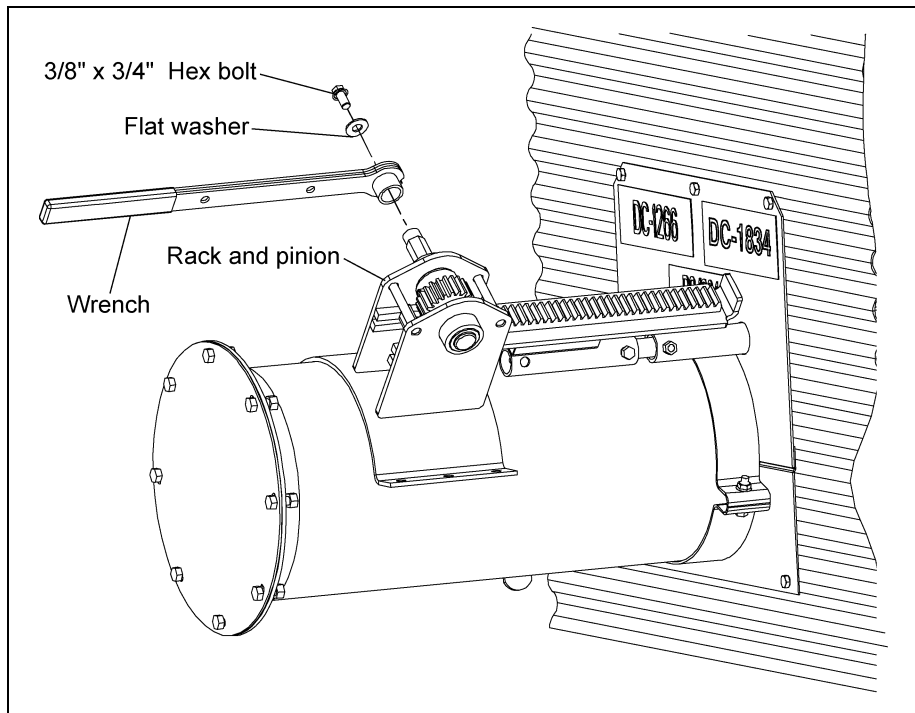

Figure 4Q 8" and 10" Systems

- With rack and pinion fully extended, attach lower half band and secure to unload tube with six (6) 5/16" x 1-1/2" bolts, washers, and serrated flange nuts. (See Figure 4R.)
- To open all gates, with center gate closed, place second 5/16" x 1-3/4" bolt through center gate control rod and intermediate gate control rod, and secure with nut. (See Figure 4R.)

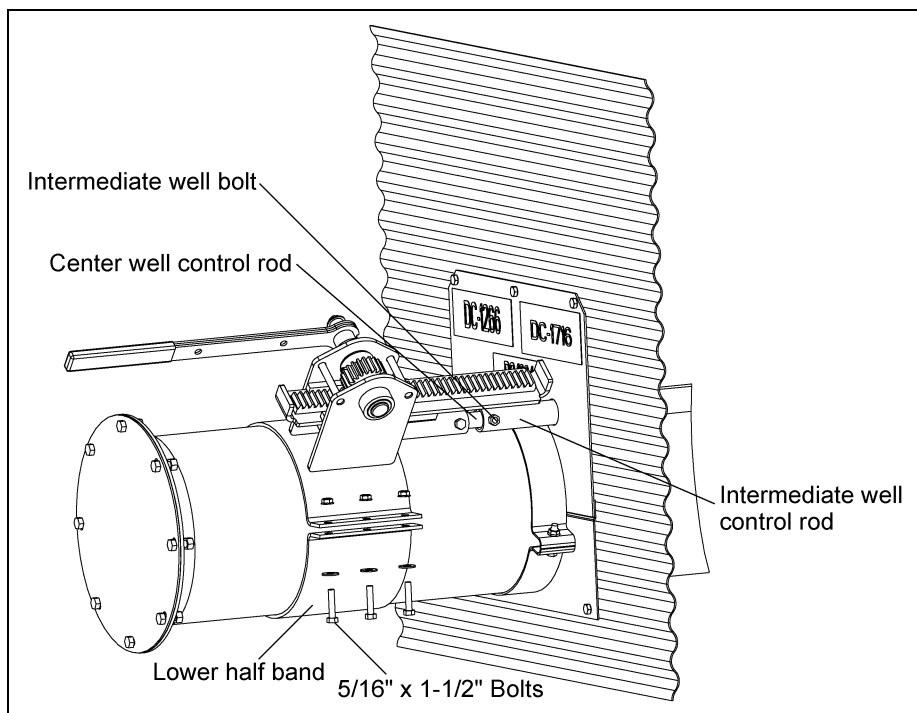

Figure 4R 8" and 10" Systems

Clutch Control Installation

1. Slide the clutch control pipe through the bin flange and the support brackets on the intermediate and center wells. Slide the clutch control pipe into clutch collar on the center well. See [Figure 4S](#) and [Figure 4T](#).

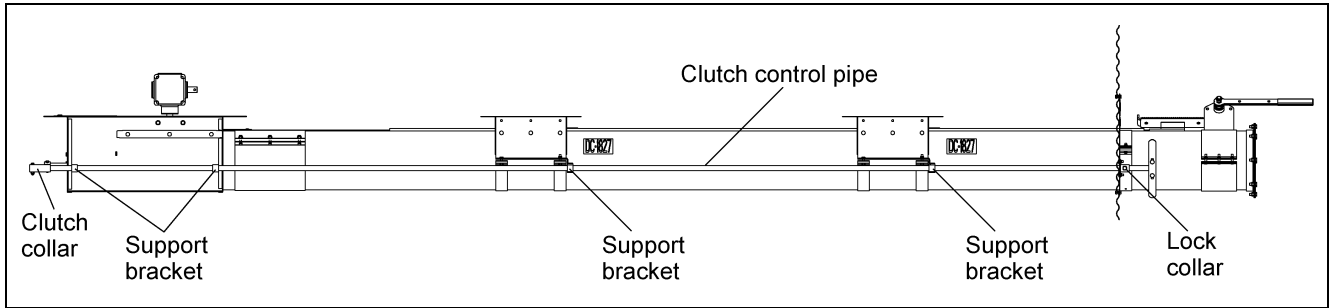

Figure 4S

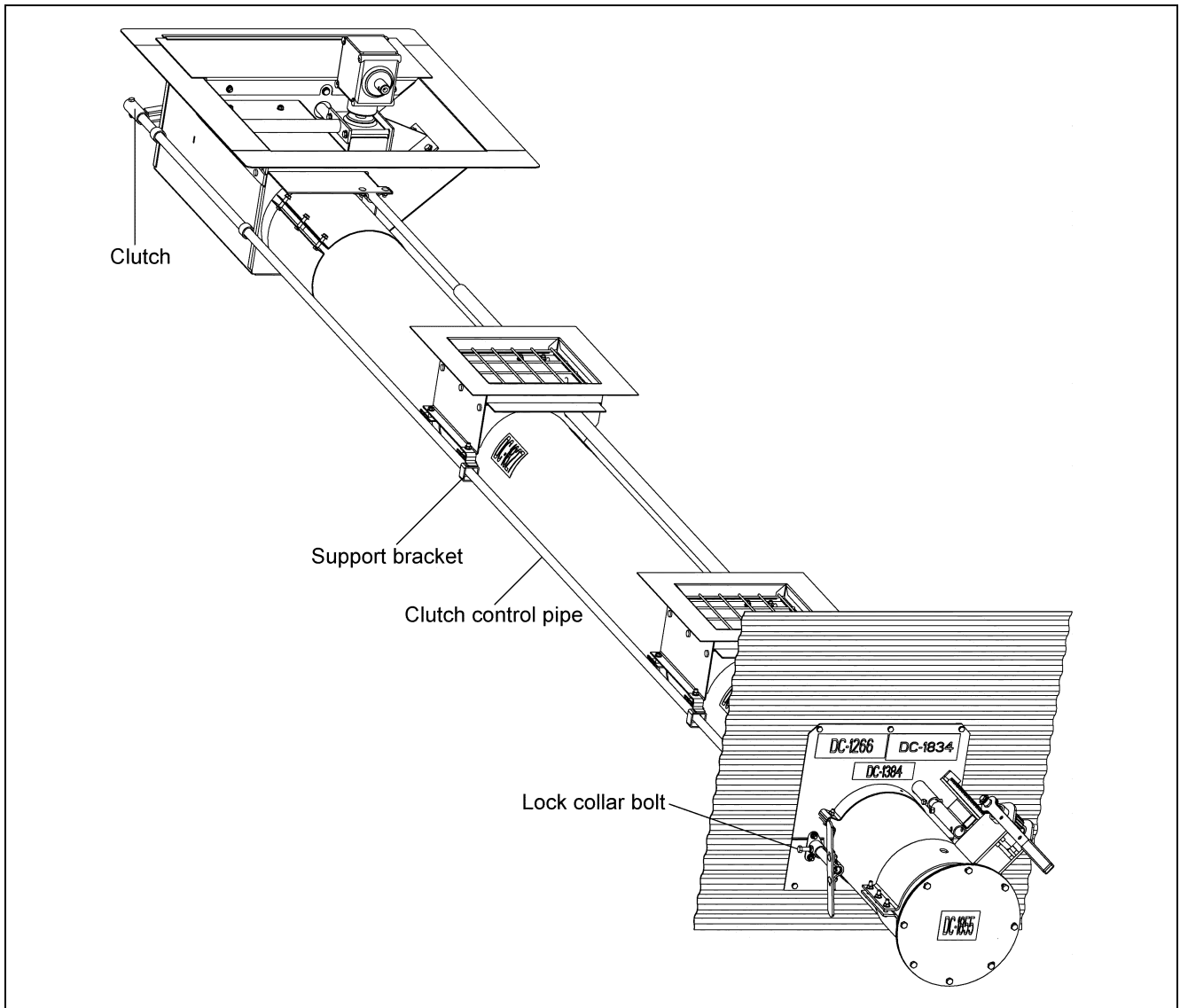

Figure 4T

2. Bolt the clutch control pipe to the collar on the center well using a 5/16" x 1-3/4" long bolt and lock nut. (See Figure 4U.)

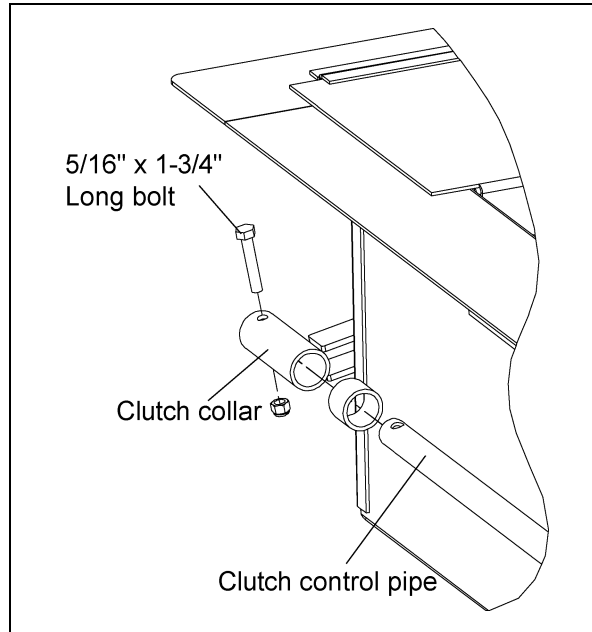

Figure 4U

3. Attach clamp to the control pipe by sliding 5/16" x 1-3/4" long roll pin through the clamp and control pipe. Fasten the clamp handle by using two (2) 5/16" x 3/4" carriage bolts, and serrated flange nuts. Install nuts so they secure the 5/16" x 1-3/4" long roll pin in place. (See Figure 4V.)

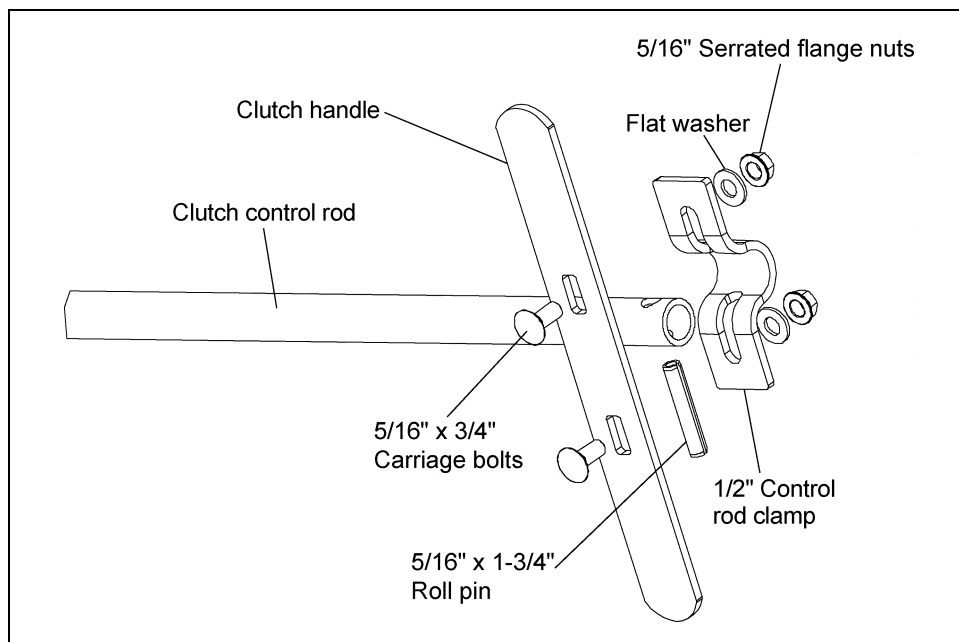

Figure 4V

NOTE: Clutch control pipe is shipped *INSIDE* unload flight.

4. Check operation of clutch by pulling the handle to engage the clutch and then pushing the handle to disengage it. The control pipe should slide freely. Lock the control pipe into the disengaged position by tightening the bolt on the lock collar that is attached to the bin flange. (See Figure 4T on Page 26.)

Installing the Unload Tube Flight

1. Begin by removing the tube end cap if you have not already done so.
2. Insert the flight into the tube with the square bushing end facing the center well and the round bushing end facing the discharge end of the tube. (See Figure 4W.)

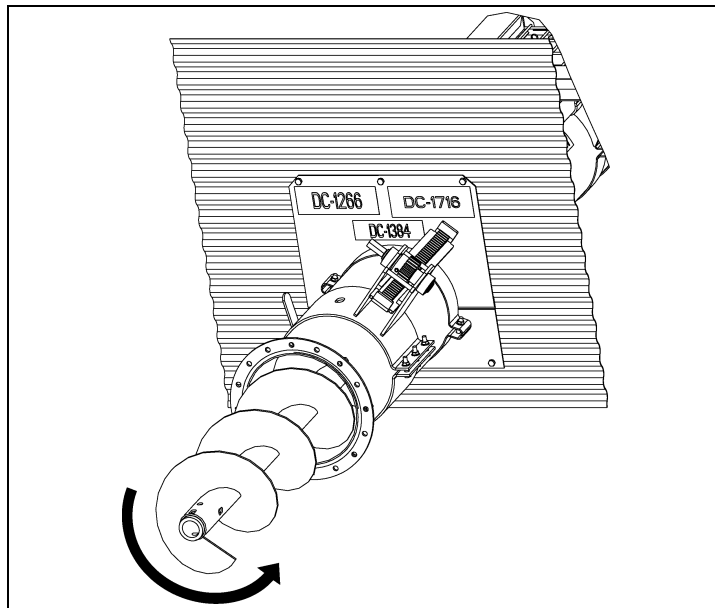

Figure 4W

3. When the flight is approaching the clutch shaft, it will be necessary to rotate the flighting counterclockwise in order to get it to seat properly on the squared clutch shaft. When the flight is properly seated, the flight should be entirely inside the unload tube. It may be necessary to pull the flight out, a small amount and attempt this step multiple times in order to seat the flight properly. (See Figure 4X.)

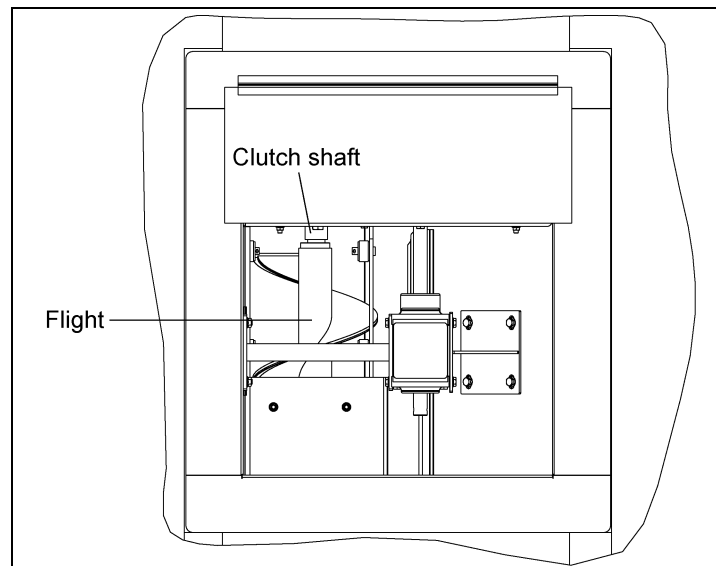

Figure 4X

4. On the initial stage, install with an empty bin, the installer might want to open the center well and enter the bin to check and see that the flight is seated. Once they have seen that it has seated, they will know the proper position of the flight on the discharge end when it has seated properly. (See Figure 4W.)

Install the Sweep Flighting

1. Assemble the U-joint.
 - a. Insert the stub into the U-joint.
 - b. Secure the U-joint using a 5/16" x 2" roll pin. (See [Figure 4Y.](#))

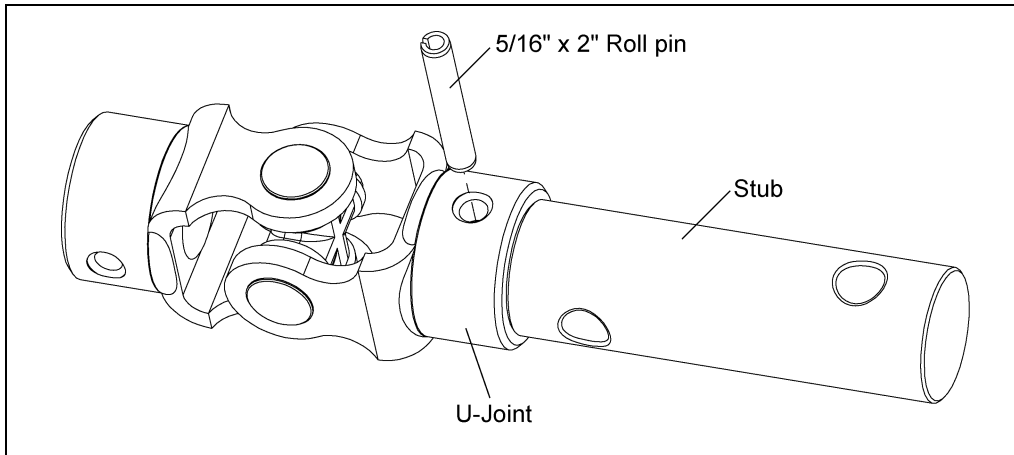

Figure 4Y

2. Attach the U-joint.
 - a. Slide the U-joint onto the top gear box output shaft.
 - b. Secure the U-joint using a 5/16" x 2" roll pin. (See [Figure 4Z.](#))

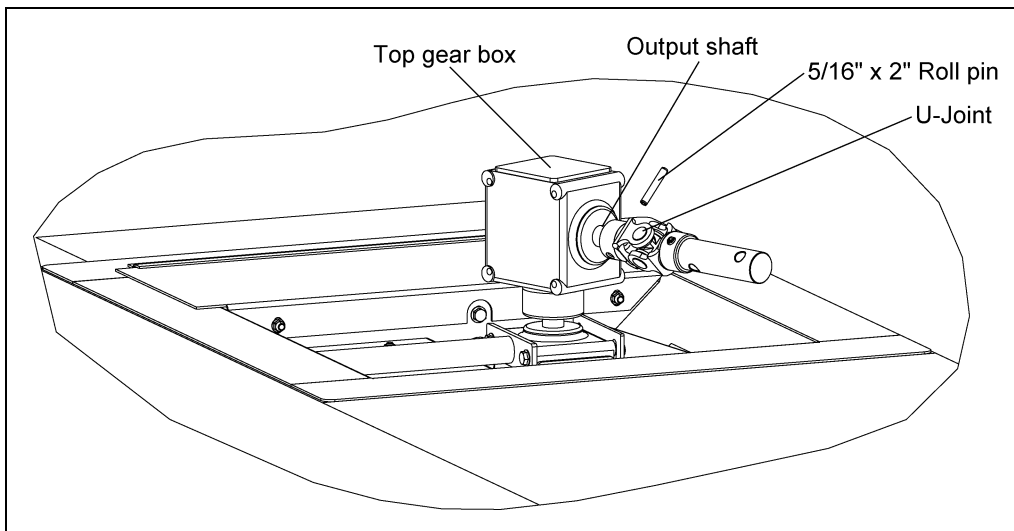

Figure 4Z

4. Installation

3. Install the pivot bracket.

- a. Attach the pivot bracket to the left side of the gear box using four (4) 3/8" x 3/4" flange bolts. (See Figure 4AA.)

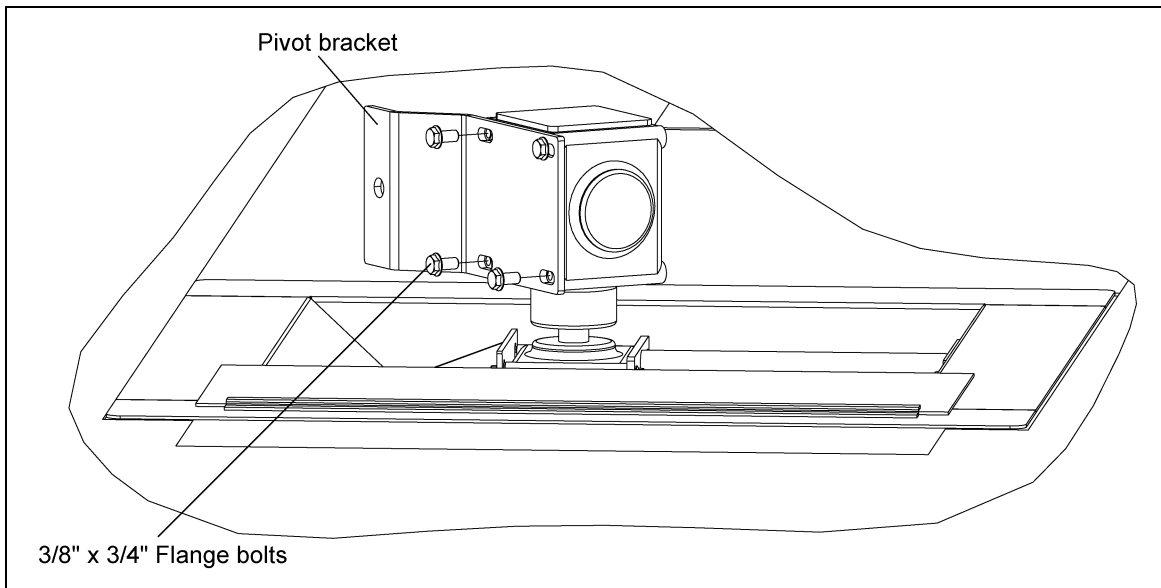

Figure 4AA

4. Install the flighting.

- a. Attach a flighting section to the U-joint stub located on the gear box. Making sure that the dura edge side of the flight faces the center of the bin. Secure it with bolts (see note for bolt size), and stover nuts. (See Figure 4AB.)

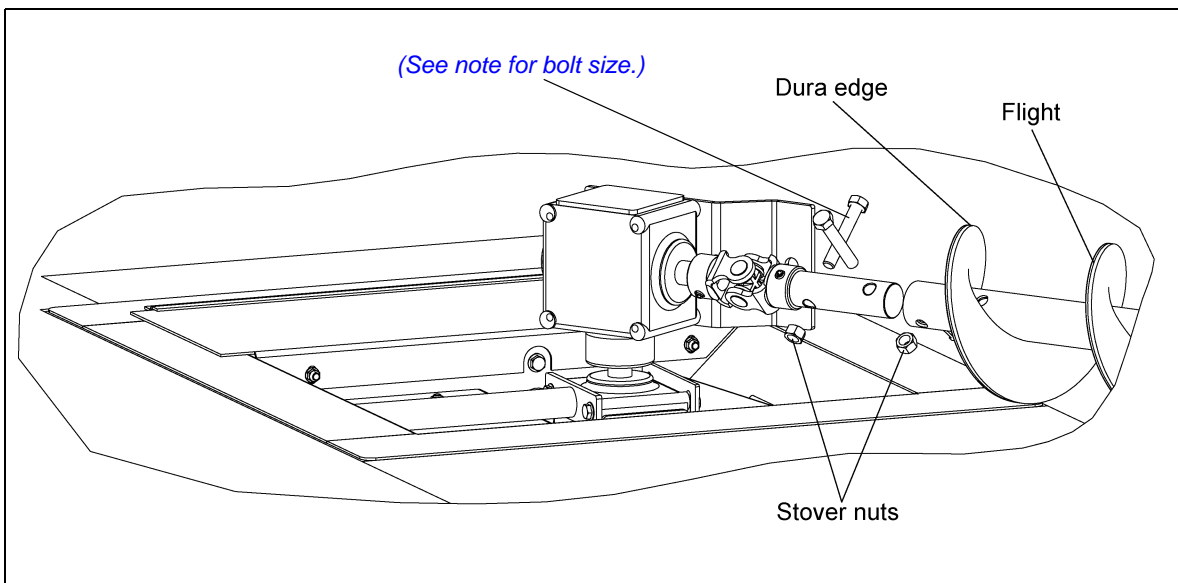

Figure 4AB

NOTE: 6" Two (2) 7/16" x 2-1/2" bolts
8" Two (2) 1/2" x 3" bolts
10" Two (2) 1/2" x 3" bolts

Use the *Chart below* to determine the number of flighting and shield sections needed for the length of sweep to be used.

Bin Size	Number of Flighting and Shields Required	Lengths
15'	1	5' 6"
18'	1	7' 0"
21'	1	8' 6"
24'	1	4' 4"
	1	5' 6"
27'	1	5' 6"
	1	5' 10"
30'	1	5' 6"
	1	7' 4"
33'	1	5' 10"
	1	8' 6"
36'	1	7' 4"
	1	8' 6"
39'	1	8' 6"
	1	8' 10"
42'	1	4' 4"
	1	7' 0"
	1	7' 4"
48'	1	7' 0"
	2	7' 4"

5. Install the connecting stub to sweep flight.

- a. Insert the connecting stub into the flighting. Secure it with bolts (*see note for bolt size on Page 30*), and stover nuts. (*See Figure 4AC.*)

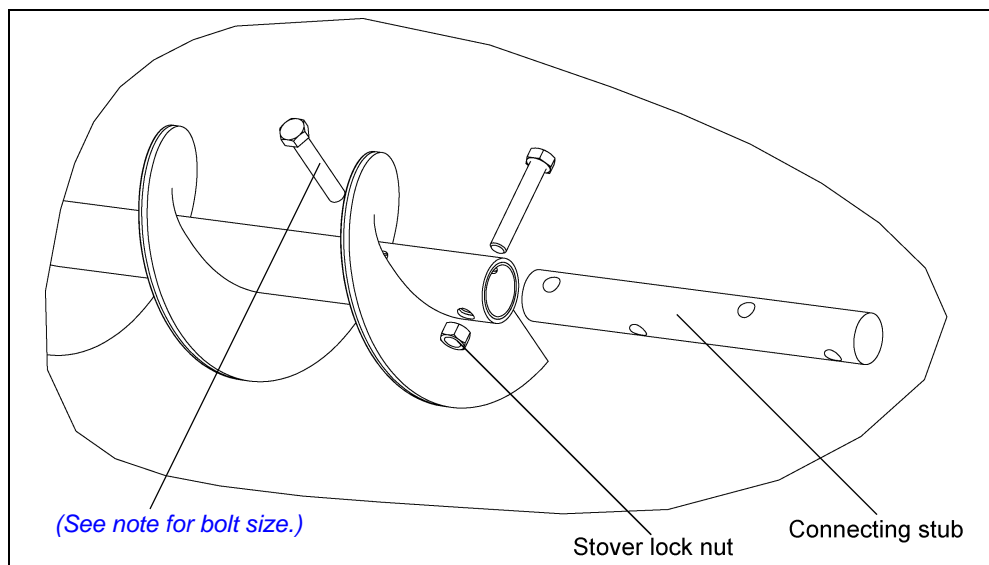

Figure 4AC

4. Installation

6. Install the bearing bracket.

a. Place the hanger bearing bracket onto the connecting stub. (See Figure 4AD.)

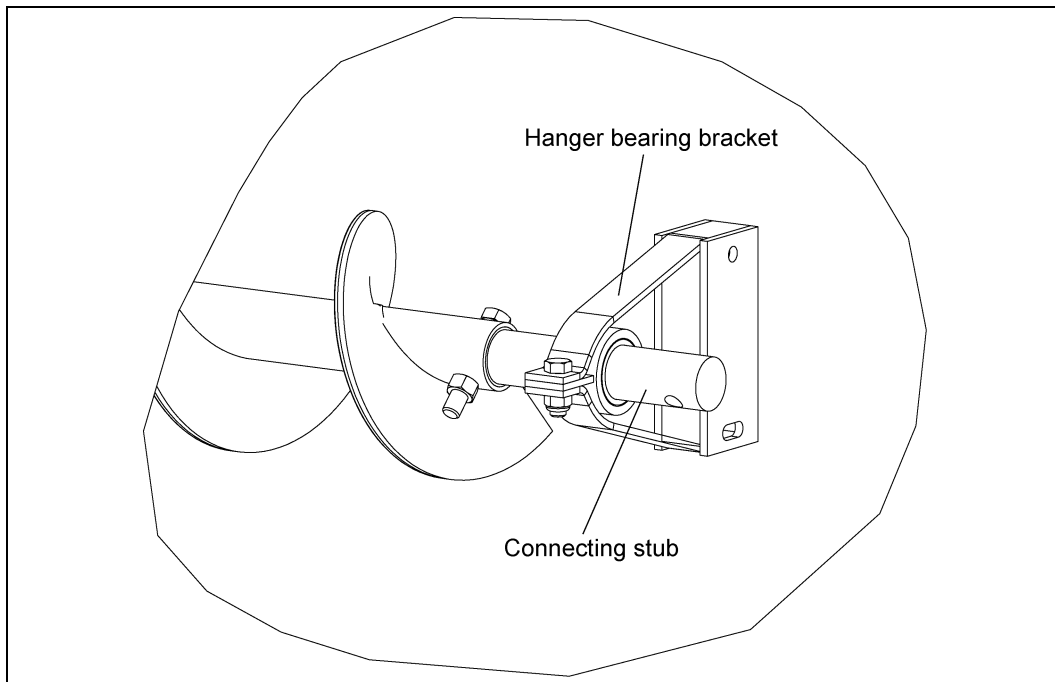

Figure 4AD

7. Install the sweep fighting.

a. Install the next section of fighting onto the connecting stub. Secure the fighting with bolts (see note for bolt size on Page 30) and stover nuts. (See Figure 4AE.)

b. Keep repeating Steps 5-7 for additional sections of fighting.

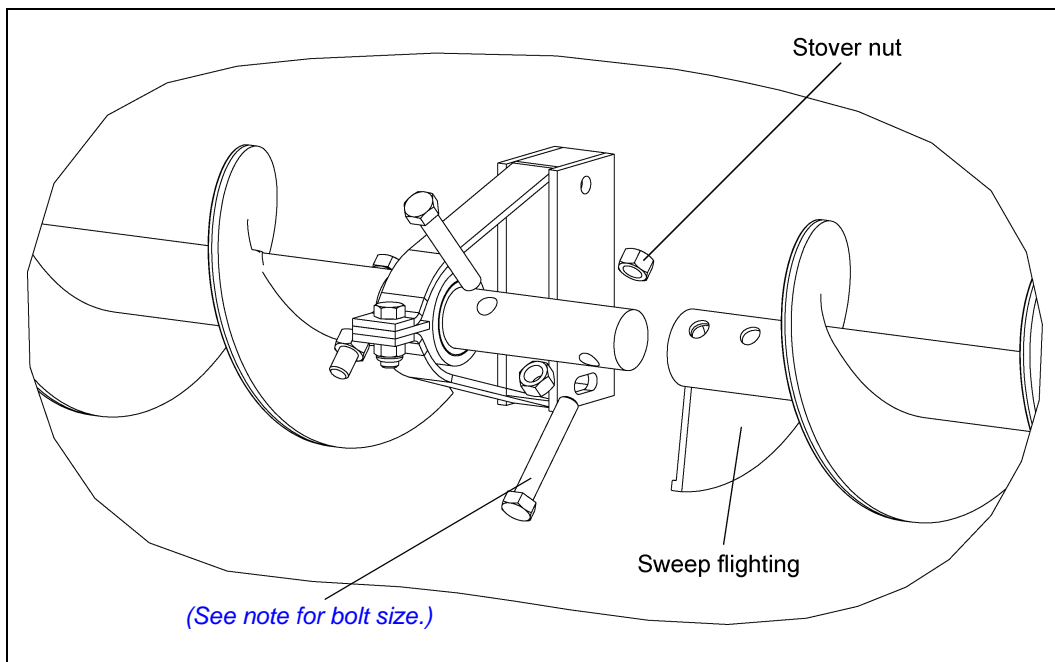

Figure 4AE

8. Install the lighting shield.

- a. Install the first shield to the shield mounting bracket. Secure using two (2) 3/8" x 1-1/4" bolts, flat washers, and lock nuts. Make sure the nut is on the side of the slotted hole for adjustment. (See Figure 4AF.)
- b. Fasten the shield bracket to the pivot bracket on the gear box using one (1) 5/8" x 1-1/2" bolt and lock nut. (See Figure 4AF.)

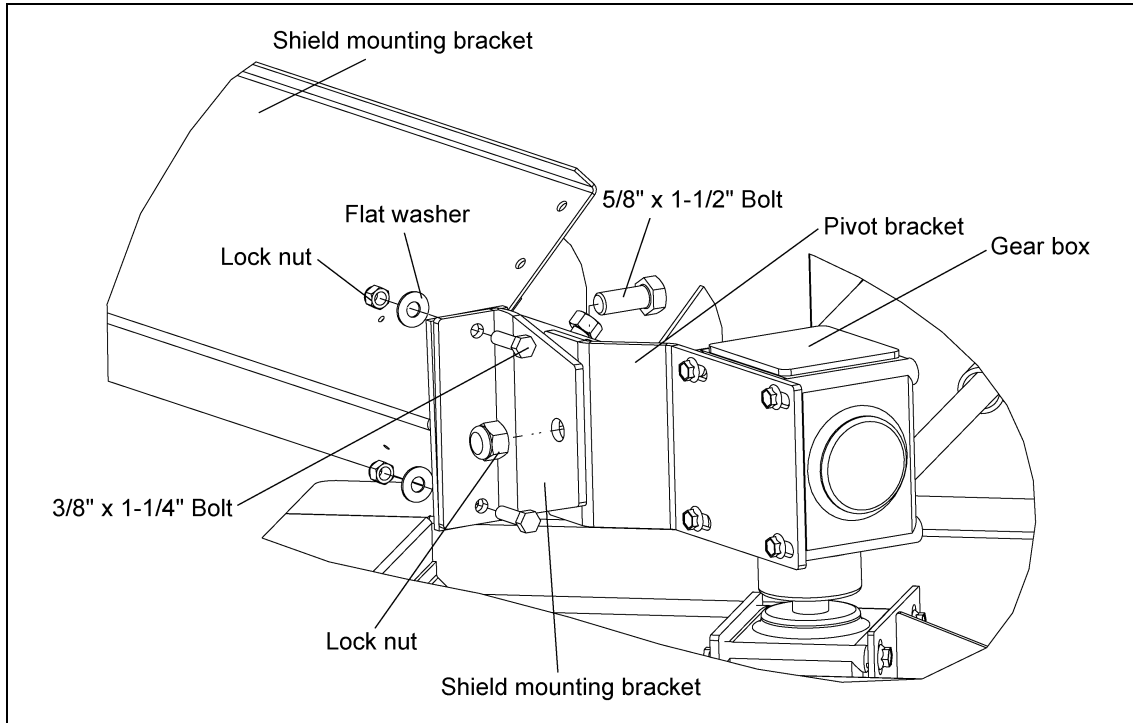

Figure 4AF

- c. Install the first and second lighting shield to the hanger bracket (when applicable) using two (2) 3/8" x 3" carriage bolts, flat washers, and lock nuts. (See Figure 4AG.)

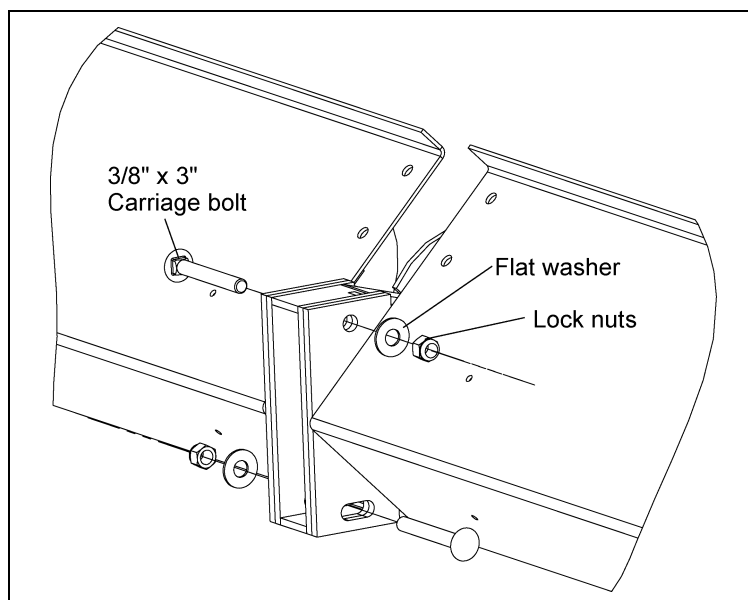

Figure 4AG

4. Installation

- d. Install shield splice brackets to back side of flighting shields using four (4) 5/16" x 3/4" bolts, flat washers, and serrated flange nuts. (See Figure 4AH.)

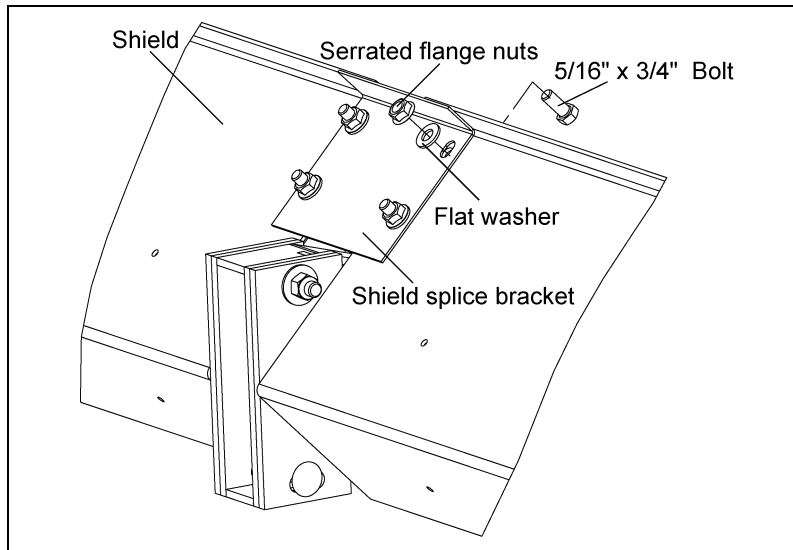

Figure 4AH

Sweep Wheel Installation

1. Insert the 4-3/8" long bushing into the flight making sure to align the outer most hole in the flight with the hole in the bushing. Align the slot in the wheel shaft with the hole in the bushing and insert the shaft into the bushing. Connect them all together using a 3/8" x 2-1/2" grade 8 HHCS bolt for 6" and a 3/8" x 3" grade 8 HHCS bolt for 8" and 10" along with the appropriate sized lock nut. Mount the sweep wheel to the back shield using 3/8" x 1-3/4" HHCS bolts, flat washers, and lock nuts. Use spacers as necessary to connect the wheel angle bracket to the back shield. (See Figure 4AI.)

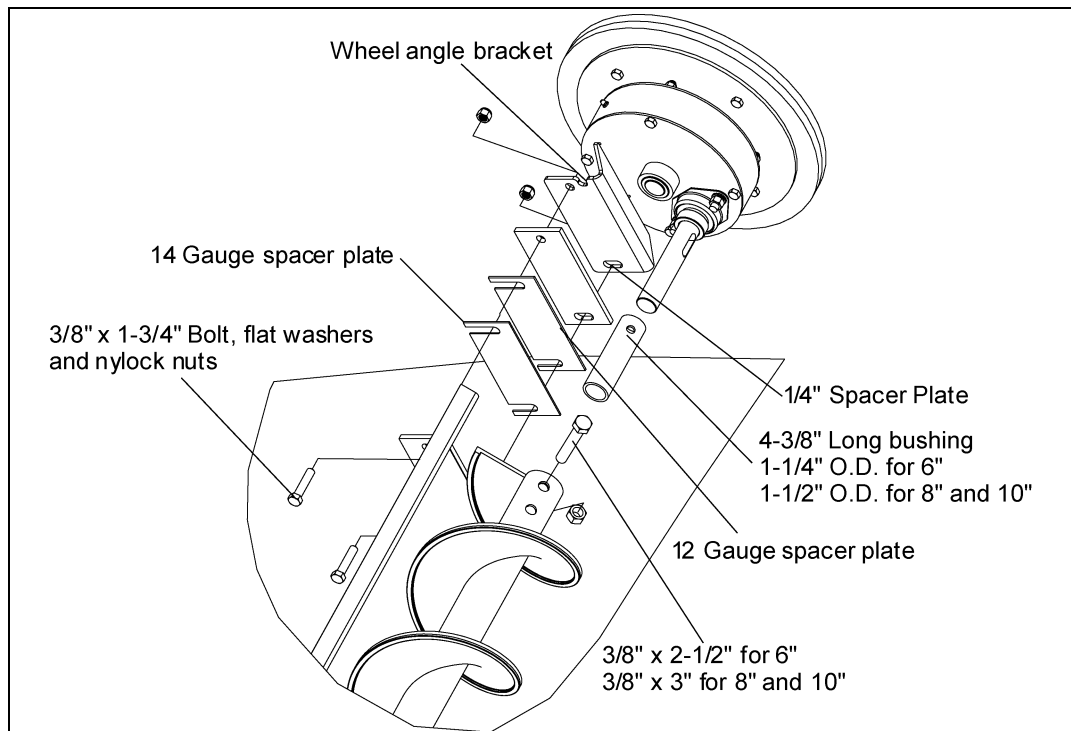

Figure 4AI

Power Recommendations

1. The horsepower recommendations are for augering reasonably dry grain. High moisture grain above (15%) will require greater power if maximum capacity is to be maintained. The maximum possible capacity will be less with high moisture grain than with dry grain. Use an electric motor of the correct size that operates at 1750 RPM. DO NOT use a motor size that is greater than what is shown for the largest bin size in your column.
2. Consideration should be given to the proper size auger for a batch drying or any intermittent type operations. When augers are stopped and restarted under full load, it may result in damage to the auger. Using a larger diameter auger and reducing its load level will be far better than subjecting a smaller diameter auger to big loads. If an auger is kept from absolute filling, it will make start-up easier and will convey more efficiently.

NOTE: *The auger capacity can fluctuate greatly under varying conditions. Moisture content, different commodities, amount of foreign matter and speeds all play a part in the performance of the auger. Twenty-five percent (25%) moisture may cut capacity by as much as forty percent (40%) under some conditions.*

Horsepower Chart

Bin Diameter	Horizontal Head			25 Degree Head			Vertical Head		
	6"	8"	10"	6"	8"	10"	6"	8"	10"
15'	3	3	-	3	5	-	5	5	-
18'	3	3	-	3	5	-	5	5	-
21'	3	5	-	5	5	-	5	7-1/2	-
24'	3	5	7-1/2	5	5	10	5	7-1/2	10
27'	5	5	7-1/2	5	5	10	5	7-1/2	10
30'	5	5	7-1/2	5	7-1/2	10	7-1/2	7-1/2	15
33'	5	5	7-1/2	5	7-1/2	10	7-1/2	7-1/2	15
36'	5	7-1/2	10	5	7-1/2	10	7-1/2	7-1/2	15
39'	-	7-1/2	10	-	10	15	-	-	-
42'	-	7-1/2	10	-	10	15	-	-	-
48'	-	7-1/2	10	-	10	15	-	-	-



1. *Electric motors and controls must be installed by a qualified electrician and must meet the standards set by the National Electrical Code and all local and state codes.*
2. *A main power disconnect switch capable of being locked only in the OFF position shall be provided. This shall be locked whenever work is being done on the auger.*
3. *A magnetic starter should be used to protect your motor when starting and stopping. It should stop the motor in case of power interruption, conductor fault, low voltage, circuit interruption or motor overload. Then the motor must be restarted manually. Some motors have built-in thermal overload protection. If this type motor is used, use only those with a manual reset.*
4. *The motor starting controls must be located outside the bin. Locate the motor starting controls outside the bin but near the bin door so the operator has full view of the operation inside the bin.*
5. *Disconnect power before resetting motor overloads.*
6. *Reset and motor starting controls must be located so that the operator has full view of the entire operation.*
7. *Make certain electric motors are grounded.*
8. *Shut OFF power to adjust, service or clean.*

Before Filling the Bin

1. Close the center well and the intermediate well gates. Push the control pipes to close.
2. Disengage the power sweep clutch control. Push to disengage.
3. Position the sweep auger alongside the intermediate wells.



DO NOT enter the grain bin unless all power driven equipment has been shut down and locked out. Never enter the grain bin unless monitored by another person.

DO NOT enter the bin if the grain has bridged or has flowed abnormally out of the bin as [Figure 5A](#) and [Figure 5B on Page 37](#). Suffocation can occur if grain suddenly breaks loose, burying persons who are inside the bin.

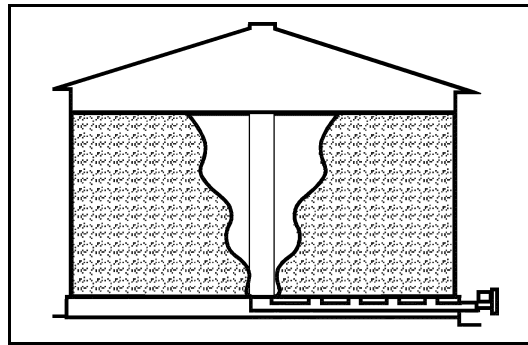

Figure 5A

Abnormal grain flow can easily fall and bury a person, suffocating them. DO NOT enter a bin with abnormal grain flow.

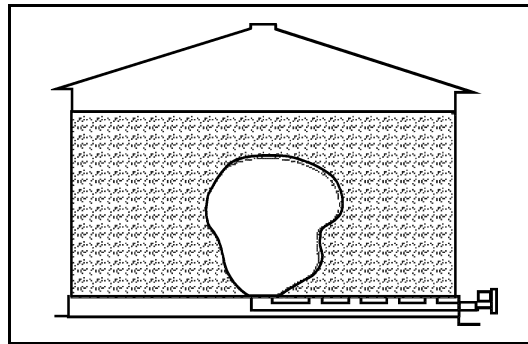

Figure 5B

Bridged grain can easily break loose and bury a person, suffocating them. DO NOT enter a bin with bridged grain.

Perform Pre-Start Checks



Failure to perform any or all of these pre-start checks may cause damage to the equipment and/or cause *SERIOUS INJURY* or *DEATH* to those in the work area. Failure to perform any or all of these pre-start checks may also be a misuse of the equipment. Any misuse of the equipment may void the warranty.

1. Make sure ALL belts are tensioned properly.
2. Make sure ALL shields are in place and that the belt(s) and pulley(s) are able to move freely.



ALWAYS keep ALL guards and shields in place, until all the power is disconnected and locked out.

3. Inspect the drive unit for any problems or potential problems.
4. Be aware of any emergency shut down procedures. Two people must always be in a position where the operation of the equipment can be monitored.
5. Before starting the auger for the first time, make sure that all parts are assembled correctly according to the instructions in this manual.



Make certain *ONLY* trained operators are in the work area before operating or moving the machine. Two people must always be in a position where the operation of the equipment can be monitored.

Operation



DO NOT start/stop the auger while it is under load, this may cause the auger to “jam”.



Failures may occur if the auger is run full before it has been “polished” during the “break-in” period.



Be aware of any unusual vibration or noises during the initial start-up and “break-in” period. If anything unusual is detected, immediately shut down the auger, and disconnect and lock out the power supply before servicing. Visually inspect the auger periodically during operation.

A. Operation for 6" systems

1. Start the unloading auger. The motor is located on the power head outside the bin on the unload tube. To figure out the horsepower needed for your equipment, use the [Horsepower Chart on Page 35](#).
2. The safety snap pin should be inserted through the center well control rod and the control lever. Make sure it has NOT been inserted through the intermediate control rod. [See Figure 5C](#).
3. Place control lever in the second slot and pull lever to open gradually until the desired flow is established. [See Figure 5C](#). It should not be necessary to open the gate more than 3" to 6".
4. Always close center well gate and allow the unloader to clean out before stopping the unloader.

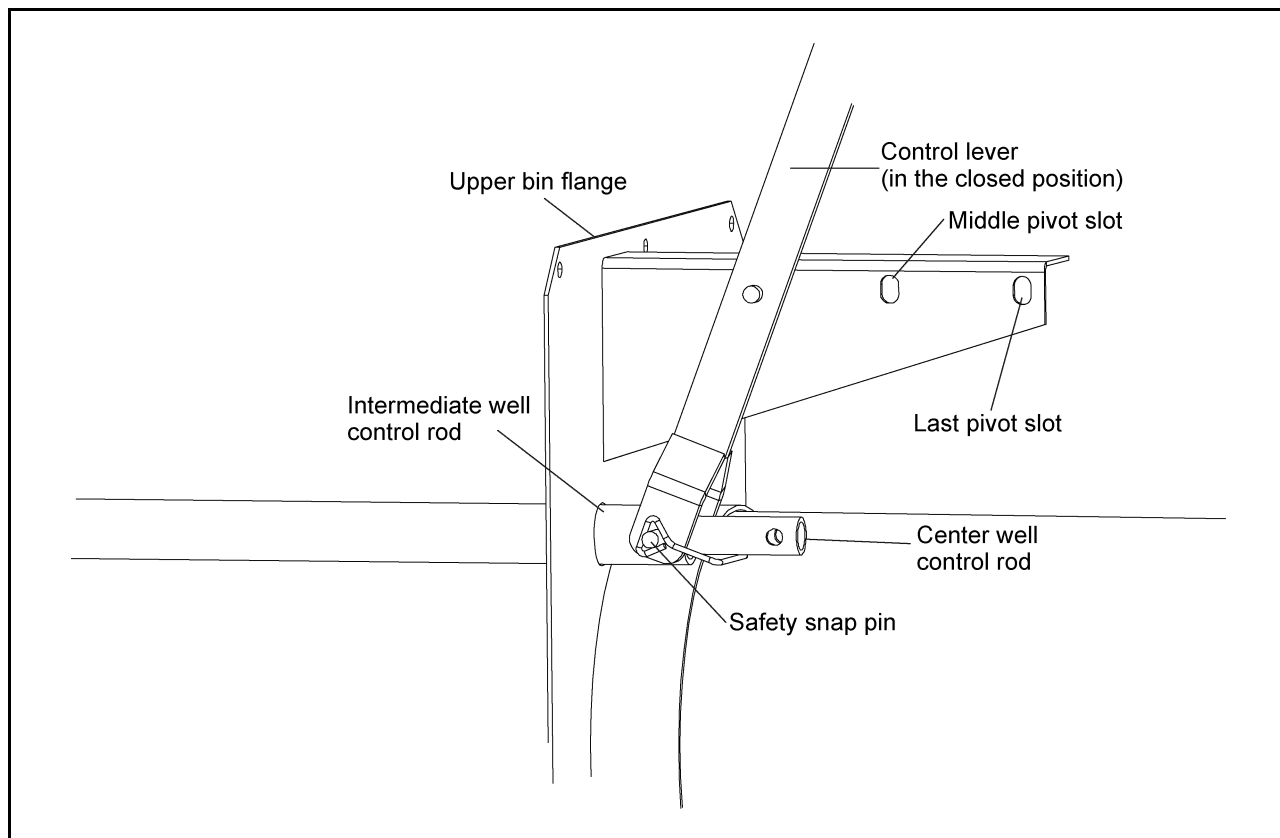

Figure 5C

5. When grain flow stops from the center well, close the center well gate. Insert the safety snap pin through the control lever and both the intermediate and center well control rods as [Figure 5E](#). The remaining grain should look similar to [Figure 5D](#).

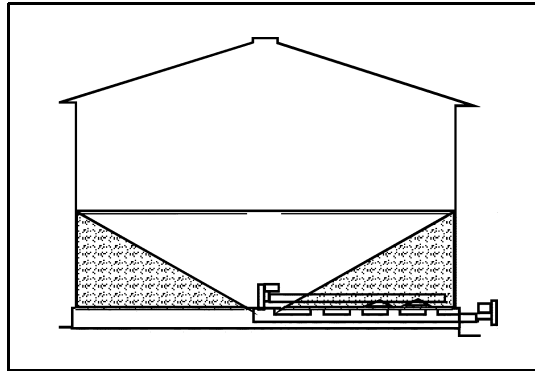

Figure 5D

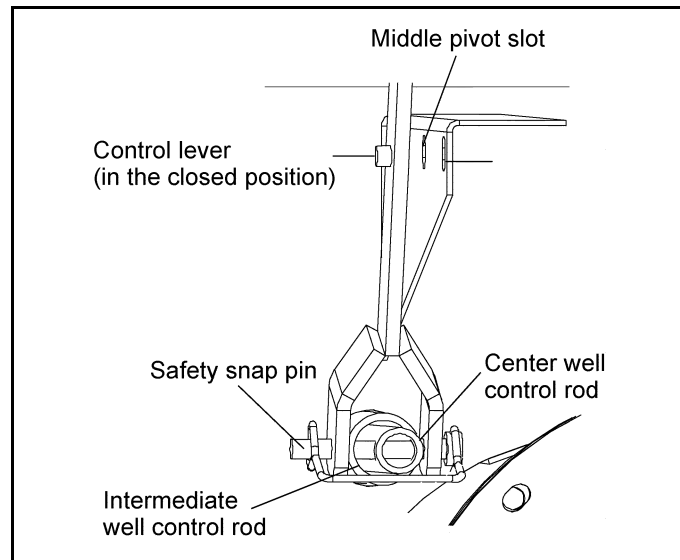

Figure 5E

6. Gradually open gates using the middle pivot slot until the desired flow of grain is reached. You should not open the gates more than 2 to 4 inches. If gates need to be opened further, use the last slot for more leverage. [See Figure 5C on Page 38](#). The remaining grain should look similar to [Figure 5F](#).

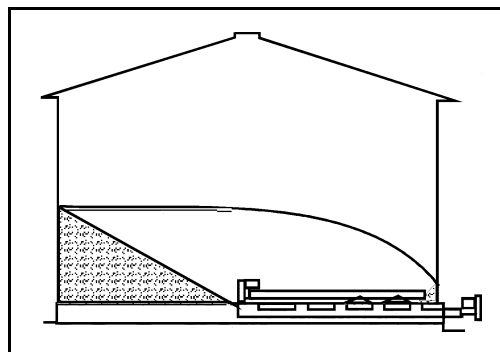

Figure 5F

5. Operation

B. For 8" and 10" systems

1. Start the unloading auger. The motor is located on the power head outside the bin on the unload tube. To find the horsepower needed for your equipment, use the [Horsepower Chart on Page 35](#).
2. Make sure the center well bolt is inserted through the rack and pinion tube and center.

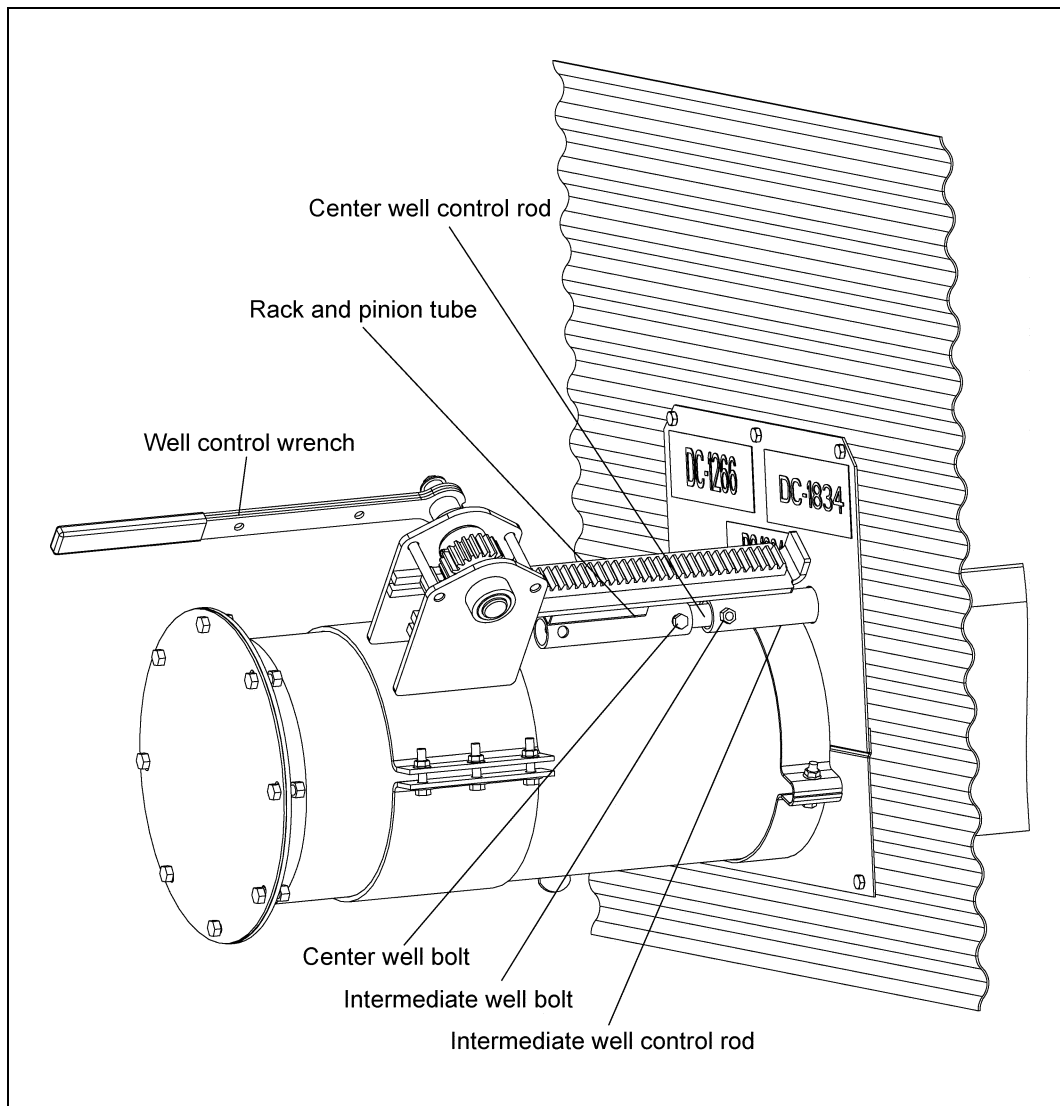

Figure 5G

3. Place wrench on rack and pinion and open center gate until desired flow is established. It should not be necessary to open gate more than 3" to 6".
4. Always close the center well gate and allow the unloader to clean out before stopping the unloader.
5. When grain flow stops from the center well, close the center well gate. Insert the intermediate well bolt through the intermediate well control rod and the center well control rod. (See [Figure 5G.](#)) Remaining grain should look like [Figure 5D on Page 39](#).
6. Gradually open the gates until the desired flow of grain is reached. You should not open the gate more than 2" to 4". The remaining grain should look like [Figure 5F on Page 39](#).

Engaging the Clutch for Bin Sweep

1. All power should be OFF and locked out before starting.
2. Loosen the lock collar set screw and pull on clutch control handle to engage clutch. (See Figure 5H.)
3. Once engagement is felt, tighten the lock collar set screw to hold the clutch engaged.
4. Fully open the center well ONLY.



Center well slide gate must be fully open during sweep operation.

5. Restore power and start the power sweep motor. The sweep auger will start along with the unload auger. The sweep auger will remain on the floor and clear most of the grain in one pass. A second pass will clean out additional grain, before final clean out.

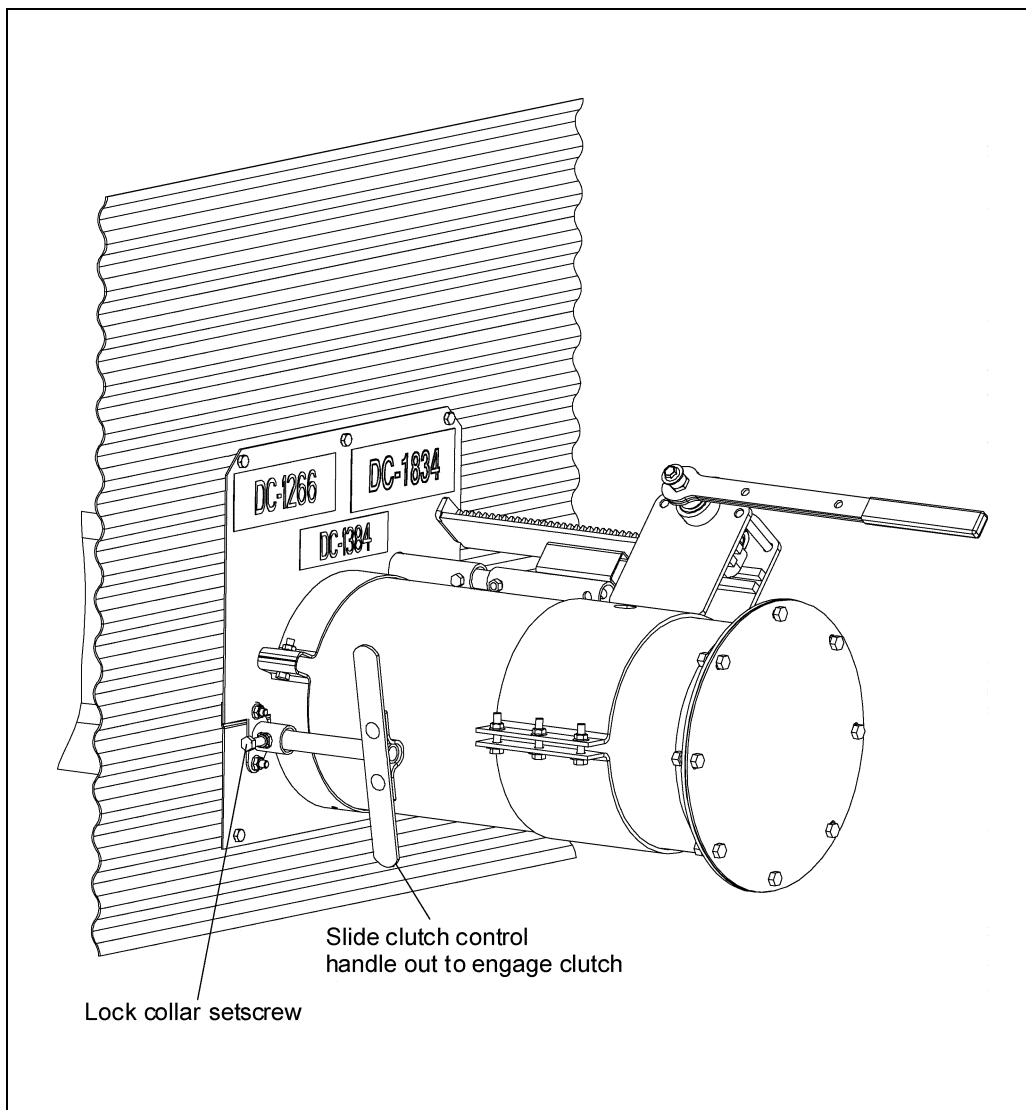

Figure 5H

5. Operation

Final Clean-Out

The following procedure is recommended for cleaning the floor of the bin after the sweep auger has removed as much grain as possible.



DO NOT enter a grain bin unless all power driven equipment has been shut down and locked out.

1. Clean (scoop and sweep by hand) the outer area of the floor into a circular pile towards the center of the bin. (See Figure 5I.)
2. Get out of the bin.
3. After making sure everyone is outside the bin and clear of the equipment, start the under floor unloader and the sweep auger. In a short time, the circular pile towards the center of the bin will have been removed.
4. Stop the equipment and lock out.
5. Scoop and sweep by hand the remaining floor area to the center of the bin.
6. Get out of the bin.
7. Repeat [Steps 3-6](#) until all grain has been removed from the bin.

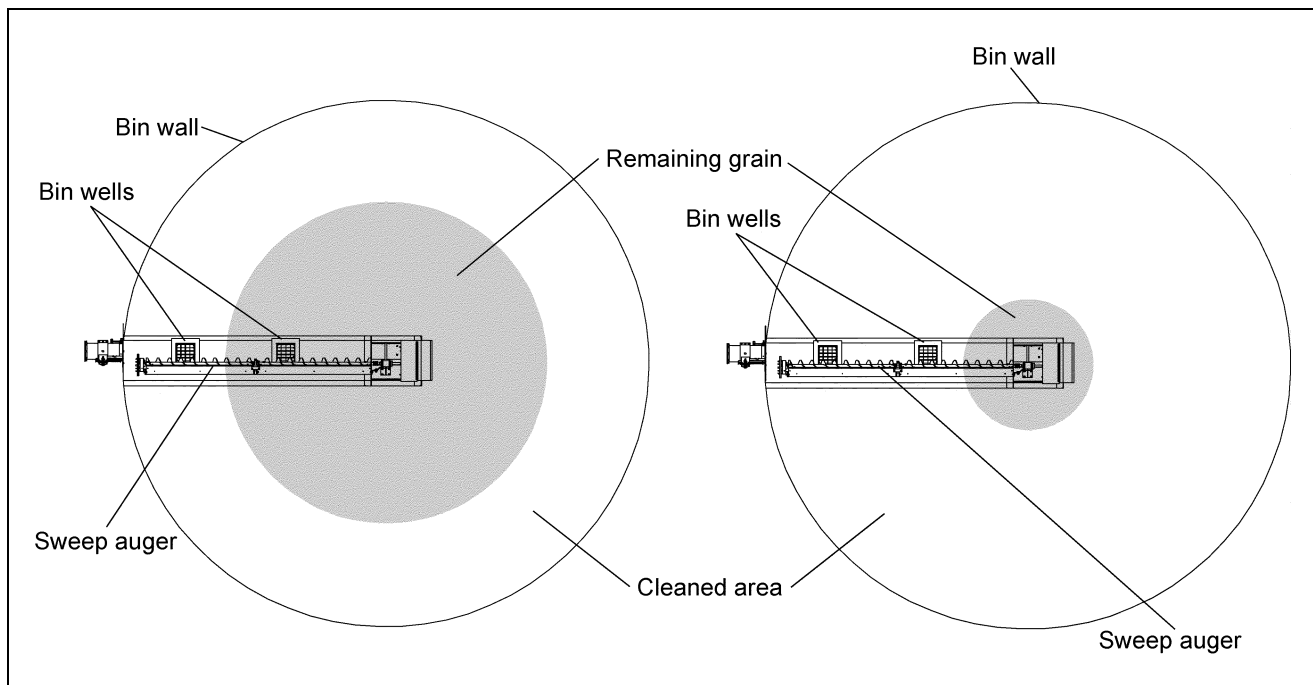

Figure 5I Top View of Bin



Keep out of bin while sweep is in operation. Rapidly traveling sweep auger. The sweep auger will move rapidly around the bin when the bin is nearly empty.



Stay clear of the under floor unloader at the bin wells. The under floor unloader is exposed at these locations in the bin floor.

Normal Shut Down

1. Before shutting down the unit, be sure the hoppers and augers are empty.
2. Disconnect and lock out the power source before leaving the work area.

Emergency Shut Down

1. Know how to shut down the auger in case of an emergency.
2. Do not restart the auger while it is under load.



NEVER start the equipment under load. Doing so may cause damage. This type of damage is considered a misuse of the equipment. Any misuse of the equipment may void the warranty.

3. Close the bin well control gates.
4. Reconnect and unlock the power source.
5. Clear the auger gradually, until there is no grain and there are no obstructions.

Storage Preparation

1. Close all wells to the discharge auger.
2. Position the direct gear drive sweep directly over the intermediate wells.

NOTE: *Make sure that the clutch control rods are disengaged.*

3. Be sure the unload tube is empty.
4. Shut down the auger.
5. Make sure all fasteners are tight.



DO NOT enter the grain bin unless all power driven equipment has been shut down.

Maintaining the Auger



*Properly maintaining this equipment will help to ensure it continues to work properly. Failure to properly maintain this equipment may result in damage to the equipment or may cause **SERIOUS INJURY** or **DEATH** to the operator.*

Failure to properly maintain this equipment may also be a misuse of the equipment. Any misuse of the equipment may void the warranty.

1. The U-joint must be lubricated with SAE multipurpose grease every 10 operational hours, or after each use.
2. The upper and lower gear boxes in the center well should be half-full with oil. They must be checked and possibly filled with SAE 80W90 gear oil every 10 operational hours. Each gear box should be filled up to the fill plug, approximately making them half-full overall. It is recommended to replace the oil in the gear boxes every season.
3. Use caution when repairing or replacing equipment parts.
4. Make sure ALL decals are legible and tightly attached to the auger. If necessary, replace them **FREE OF CHARGE** by contacting the dealer, warehouse or the manufacturer.
5. Mount controls for any electric motors at a safe distance from the machine and in a location accessible in case of an emergency.
6. Make sure ALL electrical wiring is not damaged, and that it meets proper wiring codes.
7. Make sure ALL components are in good working condition before use.

Problem	Possible Cause	Solution
The auger is vibrating.	The drive belt may be too tight, binding the head stub and flight. Damage can occur to the auger flighting, causing noise. Damage usually is caused from foreign material being run through the auger.	Adjust the drive belt to the proper tightness.
		It may be necessary to remove the flighting for inspection.
Capacity is too low.	There may not be enough grain reaching the auger.	Make sure the intake has not bridged over, restricting flow. The flighting at the intake should be covered with grain for maximum capacity.
	The auger is moving too slowly.	Check the auger speed. Low capacity will result from speeds slower than recommended.
The auger plugs.	The auger may be “jamming” because too much grain is reaching the auger.	Decrease the amount of grain the auger is gathering.
	The motor may be too small or wired improperly.	If the motor is a newer light weight aluminum type, the next larger size may be desirable.
	The grain may be wet.	If wet grain or other hard-to-move material is being augered, use a larger size motor than recommended for normal use.
	The auger may be jammed with foreign material.	Remove any foreign material in the auger.
	The discharge end may be plugged.	Unplug any plugs at the discharge end of the auger.
The sweep flight and shield are no longer moving.	Too much drag.	Check the clearance between the shield and the bin floor. Make sure there is room for the auger to move. Adjusting the shield may be necessary.
	Worn sweep wheel.	The sweep wheel wears down over time. Replace the wheel.
	Unconditioned grain.	Moisture and/or insects can cause the grain to harden or “Cake-up”. Disconnect and lock out the power to the auger before going into the bin to correct this problem or to address any other problem.

9. Parts List

1. 6" Well Gate Control Parts
2. 8" and 10" Rack and Pinion
3. 6" Intermediate Well Parts
4. 8" Intermediate Well Parts
5. 10" Intermediate Well Parts
6. Center Well Parts
7. 6" Flight and Shield Parts
8. 8" and 10" Flight and Shield Parts
9. Reduction Wheel Parts
10. 6" Bin Flange Parts
11. 8" Bin Flange Parts
12. 10" Bin Flange Parts

6" Well Gate Control Parts

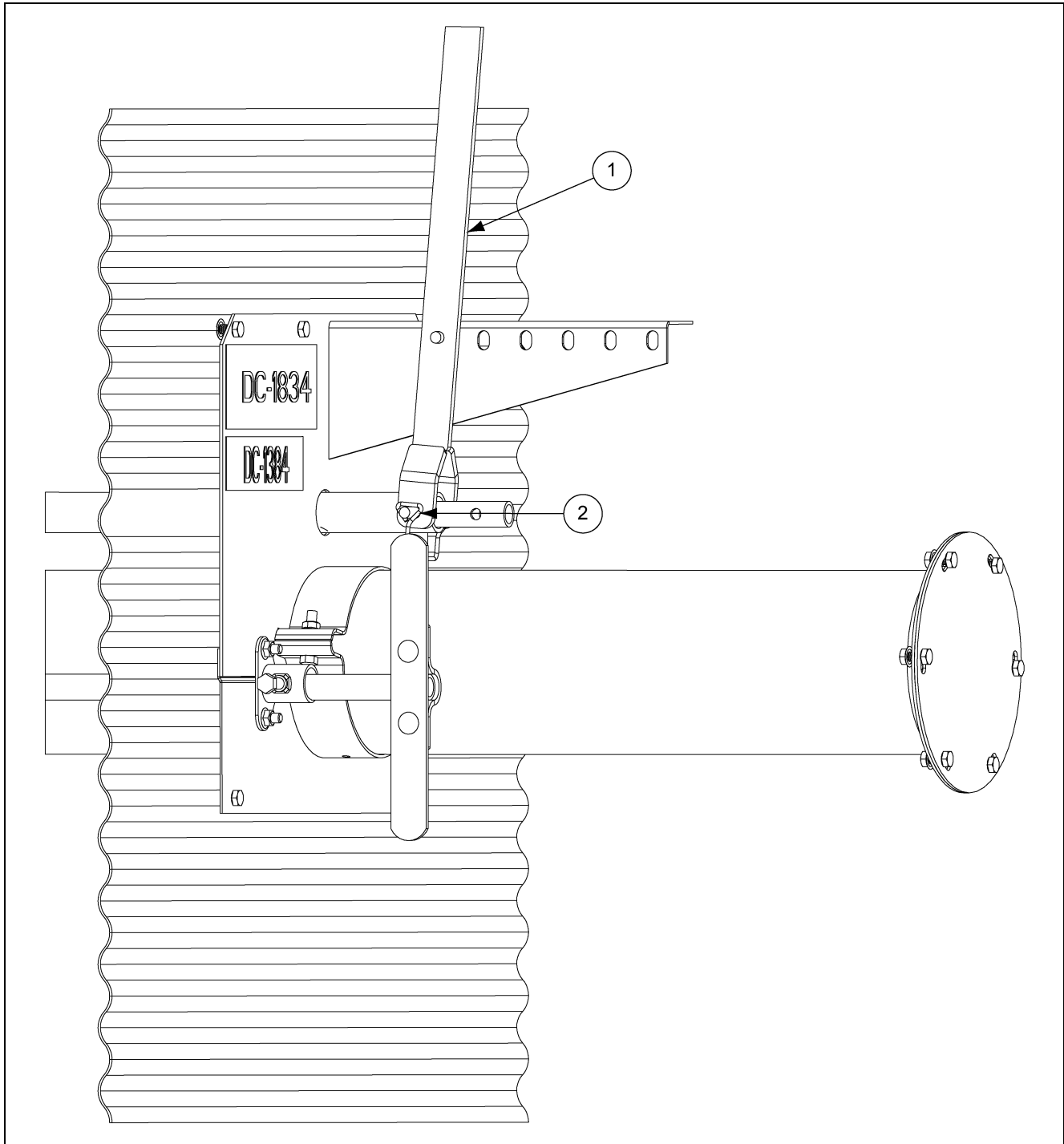

6" Well Gate Control Parts

Ref #	Part #	Description
1	GK5063	6" Control Lever Handle Weldment
2	S-8480	3/8" x 2-3/4" Safety Snap Pin

8" and 10" Rack and Pinion

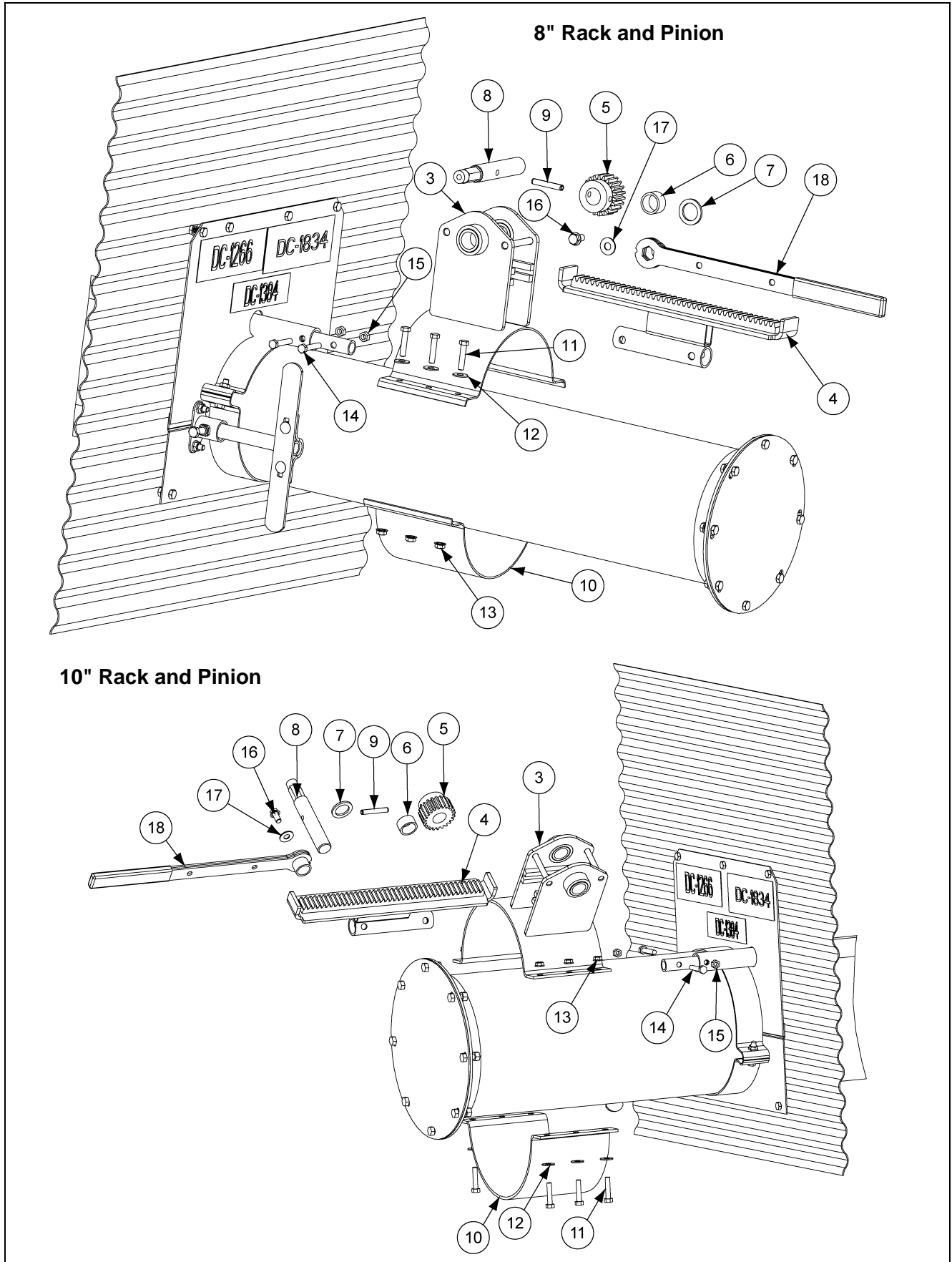

8" and 10" Rack and Pinion

Ref #	Part #	Description
3	GK6838	8" Rack and Pinion Housing Assembly
	GK6966	10" Rack and Pinion Housing Assembly
4	GK6831	8" Rack and Pinion Bar Assembly
	GK7011	10" Rack and Pinion Bar Assembly
5	GC09859	Spur Gear 10DP 1" Face 22 Teeth
6	GK6841	Rack and Pinion Spacer Tube
7	GK4211	1" Flat Washer
8	GK6845	Rack and Pinion Crank Shaft
9	S-4377	2" x 5/16" Pin Spring
10	GK1603	8" Half Band
	GK5116	10" Half Band
11	S-2741	5/16"-18 x 1-1/2" HHCS Bolt Grade 5
12	S-845	5/16" Flat Washer Grade 2 Zinc
13	S-3611	5/16"-18 Serrated Flange Nut Zinc
14	S-7149	5/16"-18 x 1-3/4" HHCS Bolt Zinc Grade 5
15	S-396	5/16"-18 Hex Nut Grade 2 Zinc
16	S-9067	3/8"-16 x 3/4" Hex Bolt
17	S-248	3/8" Flat Washer
18	GK7260	3/4" Wrench Assembly

6" Intermediate Well Parts

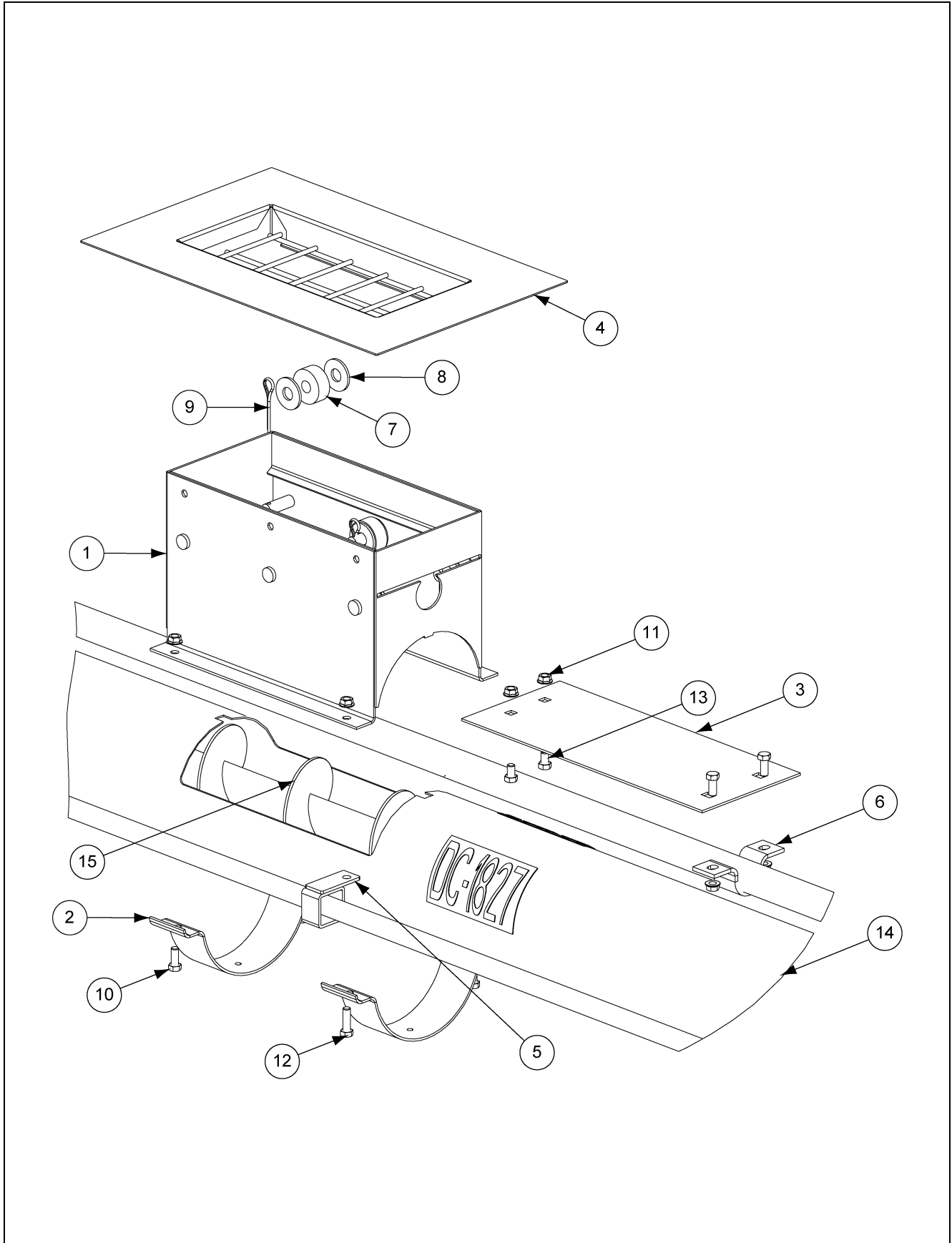

6" Intermediate Well Parts

Ref #	Part #	Description
1	GC10126	6" Intermediate Well Weldment
2	GK1053	6" Half Band
3	GK6756	6" Intermediate Well Gate
4	GK6757	6" Intermediate Well Top Flange
5	GK6713	6" Control Rod Guide
6	GC00174	Control Gate Clamp with Dimple for 6" and 8"
7	GC03064	Polyurethane Roller
8	S-2121	1/2" Flat Washer Zinc
9	S-7241	1/8" x 1-1/4" Cotter Pin Zinc Grade 2
10	S-4275	5/16"-18 x 3/4" HHTB Bolt Zinc Grade 5
11	S-3611	5/16"-18 Serrated Flange Nut Zinc
12	S-1196	5/16"-18 x 1" HHCS Bolt Grade 5
13	S-8999	5/16"-18 x 1/2" HHCS Bolt Grade 5

Tube (14)	
Part #	Description
GK6890	6" x 15' Bin 12" Well
GK6891	6" x 18' Bin 12" Well
GK6892	6" x 21' Bin 12" Well
GK6893	6" x 24' Bin 12" Well
GK6894	6" x 27' Bin 12" Well
GK6895	6" x 30' Bin 12" Well
GK6896	6" x 33' Bin 12" Well
GK6897	6" x 36' Bin 12" Well

Flight (15)	
Part #	Description
GK7020	6" x 121.25" 15' Bin
GK7021	6" x 145.25" 18' Bin
GK7022	6" x 157.25" 21' Bin
GK7023	6" x 175.25" 24' Bin
GK7024	6" x 193.25" 27' Bin
GK7025	6" x 211.25" 30' Bin
GK7026	6" x 235.25" 33' Bin
GK7027	6" x 247.25" 36' Bin

8" Intermediate Well Parts

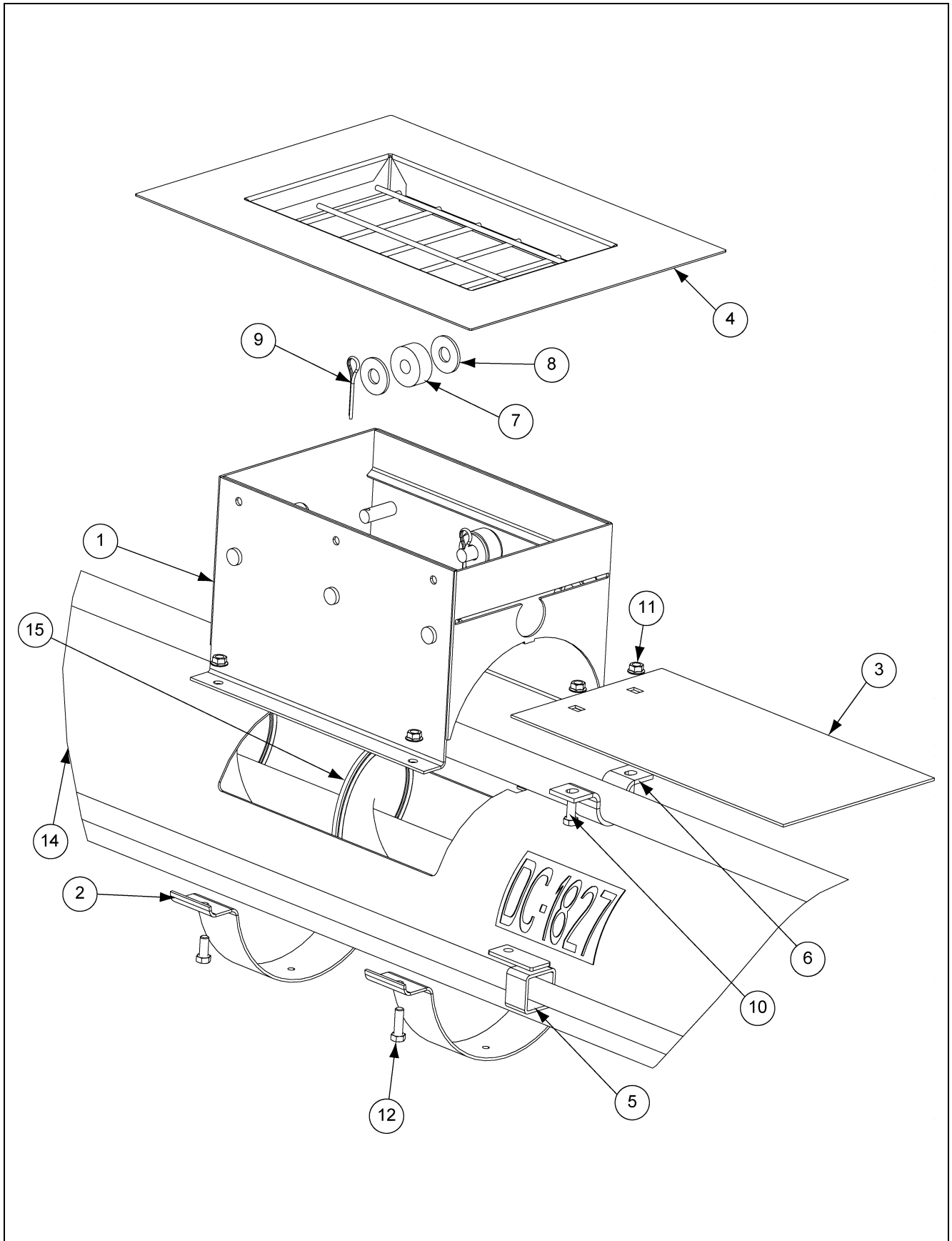

8" Intermediate Well Parts

Ref #	Part #	Description
1	GC10129	8" Intermediate Well Weldment
2	GK1055	8" Half Band
3	GK6759	8" Intermediate Well Gate
4	GK6760	8" Intermediate Well Top Flange
5	GK6711	8" Control Rod Guide
6	GC00174	Control Gate Clamp with Dimple for 6" and 8"
7	GC03064	Polyurethane Roller
8	S-2121	1/2" Flat Washer Zinc
9	S-7241	1/8" x 1-1/4" Cotter Pin Zinc Grade 2
10	S-4275	5/16"-18 x 3/4" HHTB Bolt Zinc Grade 5
11	S-3611	5/16"-18 Serrated Flange Nut Zinc
12	S-1196	5/16"-18 x 1" HHCS Bolt Grade 5

Tube (14)	
Part #	Description
GK6899	8" x 15' Bin 12" Well
GK6900	8" x 18' Bin 12" Well
GK6901	8" x 21' Bin 12" Well
GK6902	8" x 24' Bin 12" Well
GK6903	8" x 27' Bin 12" Well
GK6904	8" x 30' Bin 12" Well
GK6905	8" x 33' Bin 12" Well
GK6906	8" x 36' Bin 12" Well
GK6907	8" x 39' Bin 12" Well
GK6908	8" x 42' Bin 12" Well
GK6909	8" x 48' Bin 12" Well

Flight (15)	
Part #	Description
GK7028	8" x 121.25" 15' Bin
GK7029	8" x 145.25" 18' Bin
GK7030	8" x 157.25" 21' Bin
GK7031	8" x 175.25" 24' Bin
GK7032	8" x 193.25" 27' Bin
GK7033	8" x 211.25" 30' Bin
GK7034	8" x 235.25" 33' Bin
GK7035	8" x 247.25" 36' Bin
GK7036	8" x 265.25" 39' Bin
GK7037	8" x 289.25" 42' Bin
GK7038	8" x 325.50" 48' Bin

10" Intermediate Well Parts

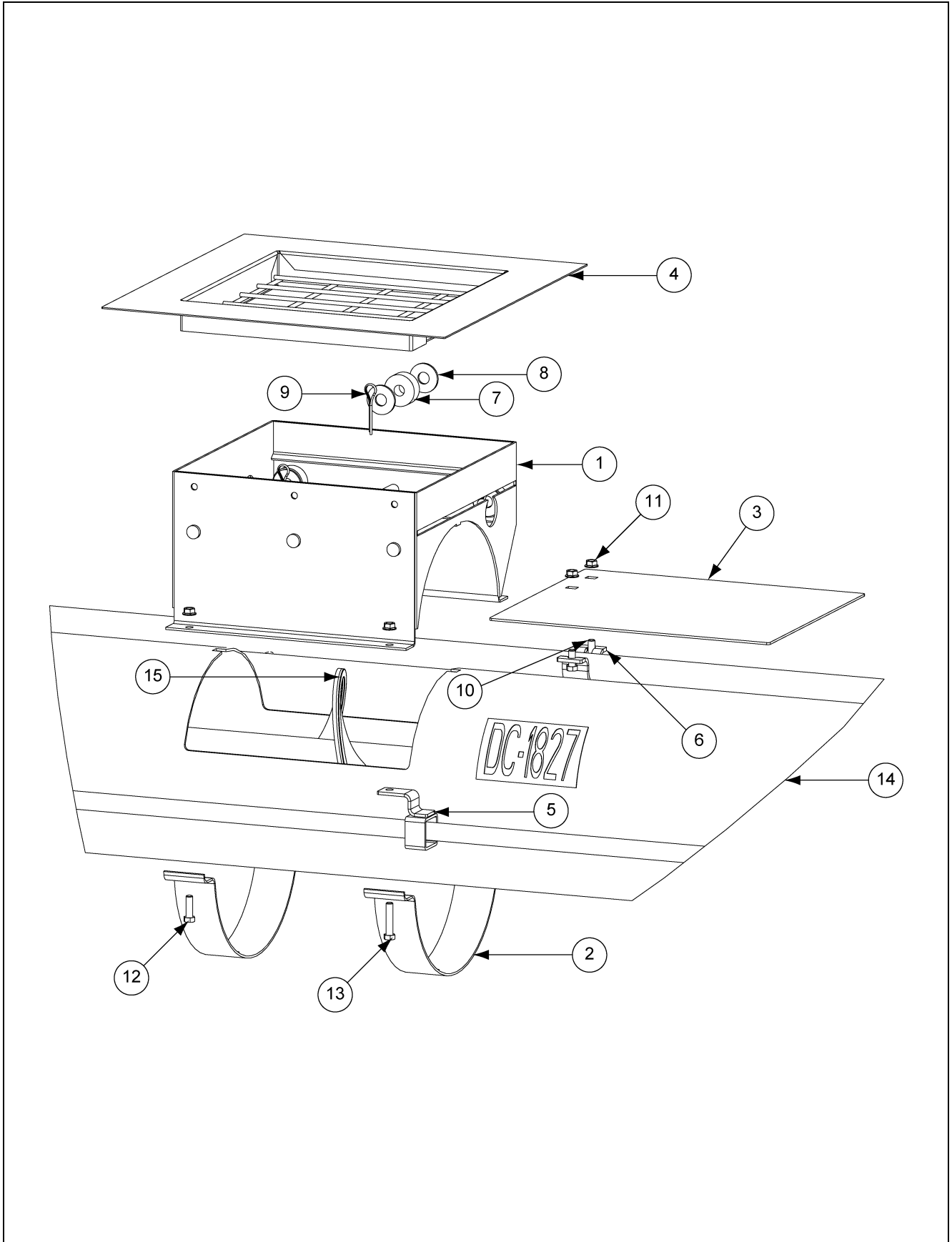

10" Intermediate Well Parts

Ref #	Part #	Description
1	GC10131	Intermediate Well Weldment
2	GK1057	10" Half Band
3	GK6762	10" Intermediate Well Gate
4	GK6763	10" Intermediate Well Top Flange
5	GK6714	10" Control Rod Guide
6	GC09006	Control Pipe Clamp with Dimple
7	GC03064	Polyurethane Roller
8	S-2121	1/2" Flat Washer Zinc
9	S-7241	1/8" x 1-1/4" Cotter Pin Zinc Grade 2
10	S-4275	5/16"-18 x 3/4" HHTB Bolt Zinc Grade 5
11	S-3611	5/16"-18 Serrated Flange Nut Zinc
12	S-1196	5/16"-18 x 1" HHCS Bolt Grade 5
13	S-2741	5/16"-18 x 1-1/2" HHCS Bolt Grade 5

Tube (14)	
Part #	Description
GK6921	10" x 24' Bin 12" Well
GK6922	10" x 27' Bin 12" Well
GK6923	10" x 30' Bin 12" Well
GK6924	10" x 33' Bin 12" Well
GK6925	10" x 36' Bin 12" Well
GK6926	10" x 39' Bin 12" Well
GK6927	10" x 42' Bin 12" Well
GK6928	10" x 48' Bin 12" Well

Flight (15)	
Part #	Description
GK7039	10" x 175.25" 24' Bin
GK7040	10" x 193.25" 27' Bin
GK7041	10" x 211.25" 30' Bin
GK7042	10" x 235.25" 33' Bin
GK7043	10" x 247.25" 36' Bin
GK7044	10" x 265.25" 39' Bin
GK7045	10" x 289.25" 42' Bin
GK7046	10" x 325.25" 48' Bin

Center Well Parts

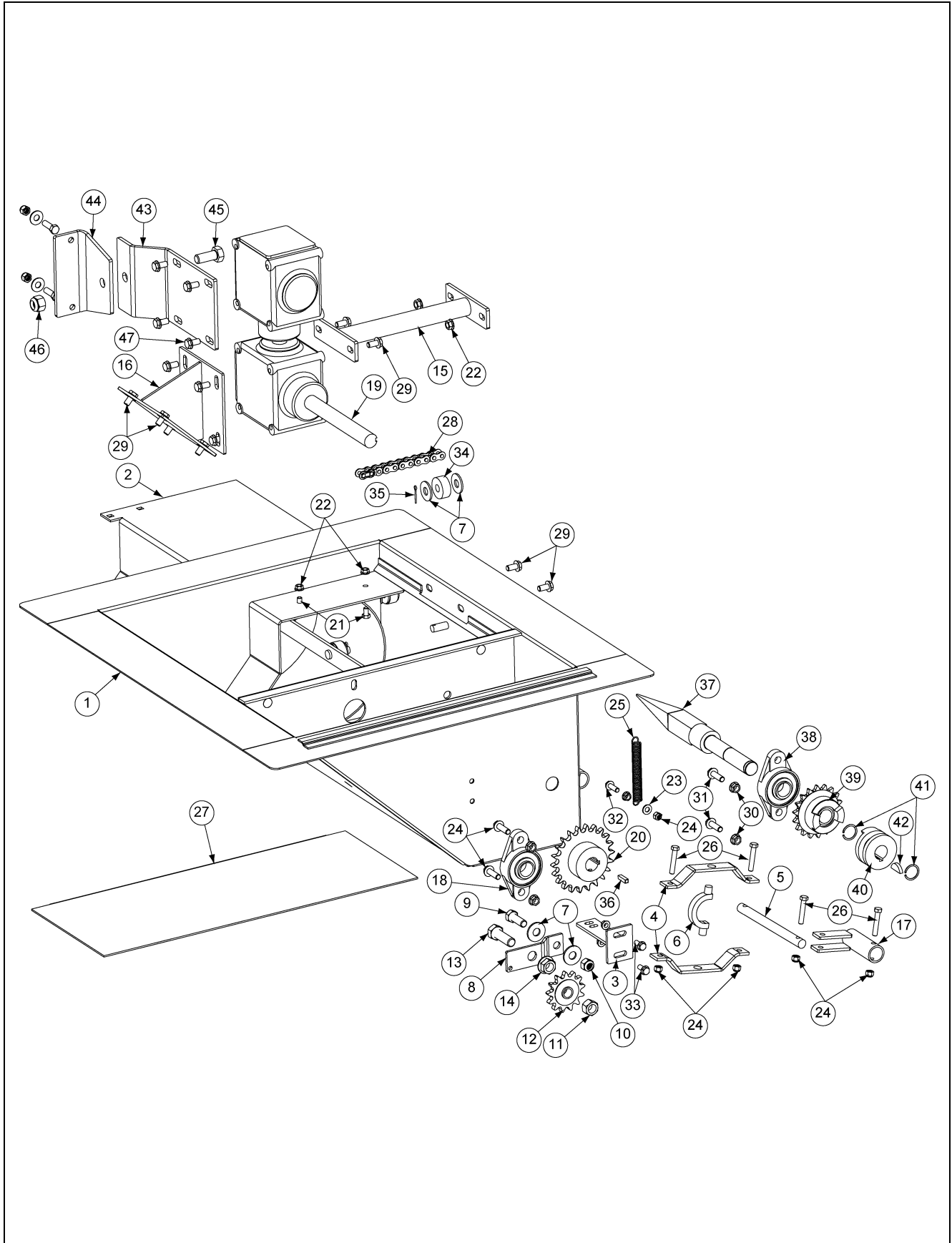

Center Well Parts

Ref #	Part #	Description	Ref #	Part #	Description
1	GK7231	6" Weldment	24	S-7382	5/16"-18 Nylock Lock Nut Zinc Grade 5
	GK7230	8" Weldment	25	GK1704	5" Return Spring
	GK7227	10" Weldment	26	S-7149	5/16"-18 x 1-3/4" HHCS Bolt Zinc Grade 5
2	GK7224	6" and 8" Slide Gate	27	GK7229	6" and 8" Cover Plate
	GK7224	10" Slide Gate		GK7228	10" Cover Plate
3	GK1693	Clutch Pivot Bracket	28	GK1705	#50 x 43P, 6" and 8" Roller Chain
4	GK1697	Clutch Yoke Bracket		GK4944	#60 x 70P, 10" Roller Chain
5	GK1695	Clutch Control Rod	29	S-9067	3/8"-16 x 3/4" Flange Bolt Zinc Grade 5
6	GK1698	Clutch Yoke	30	S 968	3/8"-16 Serrated Flange Nut Zinc
7	S-2121	1/2" Flat Washer Zinc	31	S-9066	3/8"-16 x 1-1/4" Flange Bolt Zinc Grade 5
8	GK1702	Center Well Pivot Bracket	32	S-7470	5/16"-18 x 1" Flange Bolt Zinc Grade 5
9	S-8760	1/2"-13 x 1-1/2" HHCS Bolt Zinc Grade 5	33	S-6606	5/16"-18 x 3/4" Flange Bolt Zinc Grade 5
10	S-8260	1/2"-13 Nylock Lock Nut Zinc Grade 5	34	GC03064	Polyurethane Roller
11	S-6494	5/8"-11 Deformed Lock Nut Zinc Grade 5	35	S-4322	3/32" x 1" Cotter Pin Zinc Grade 2
12	GK1701	Sprocket #50 13T 5/8" Bore	36	S-9168	1/4" x 1" Square Keyway
13	S-8399	5/8"-11 x 2" HHCS Bolt Plated Grade 5	37	GK6698	6" and 8" Clutch Stub
14	S-9259	5/8"-11 Serrated Flange Nut Zinc		GK6699	10" Clutch Stub
15	GK1688	6" and 8" Gear Box Mounting Bracket	38	GK4410	Bearing 2 hole Flange
	GK4430	10" Gear Box Mounting Bracket	39	GK1699	6" and 8" Clutch Yoke Drive Jaw
16	GK1689	6" and 8" Offset Mounting Bracket		GK6809	10" Clutch Yoke Drive Jaw
	GK4429	10" Offset Mounting Bracket	40	GK1696	Clutch Sliding Jaw
17	GK1694	6" and 8" Clutch Control Arm	41	S-8902	1" O.D. Snap Ring
	GK1923	10" Clutch Control Arm	42	S-8901	1/4" x 1" Woodruff Key
18	GK4410	Bearing 2 Hole Flange	43	GK4460	6", 8", and 10" Pivot Bracket
19	GK52081	Gear Box with Clockwise Rotation	44	GK6175	6" Shield Mounting Bracket
20	GK1110	Sprocket #50 22T 1" Bore		GK4461	8" and 10" Shield Mounting Bracket
21	S-8999	5/16"-18 x 1/2" HHCS Bolt Zinc Grade 5	45	S-9009	5/8"-11 x 1-1/2" HHCS Bolt Zinc Grade 5
22	S-3611	5/16"-18 Serrated Flange Nut Zinc	46	S-8806	5/8"-11 Nylock Lock Nut Zinc Grade 5
23	S-1937	5/16" Flat Washer Zinc	47	S-9067	3/8"-16 x 3/4" Flange Bolt Zinc Grade 5

6" Flight and Shield Parts

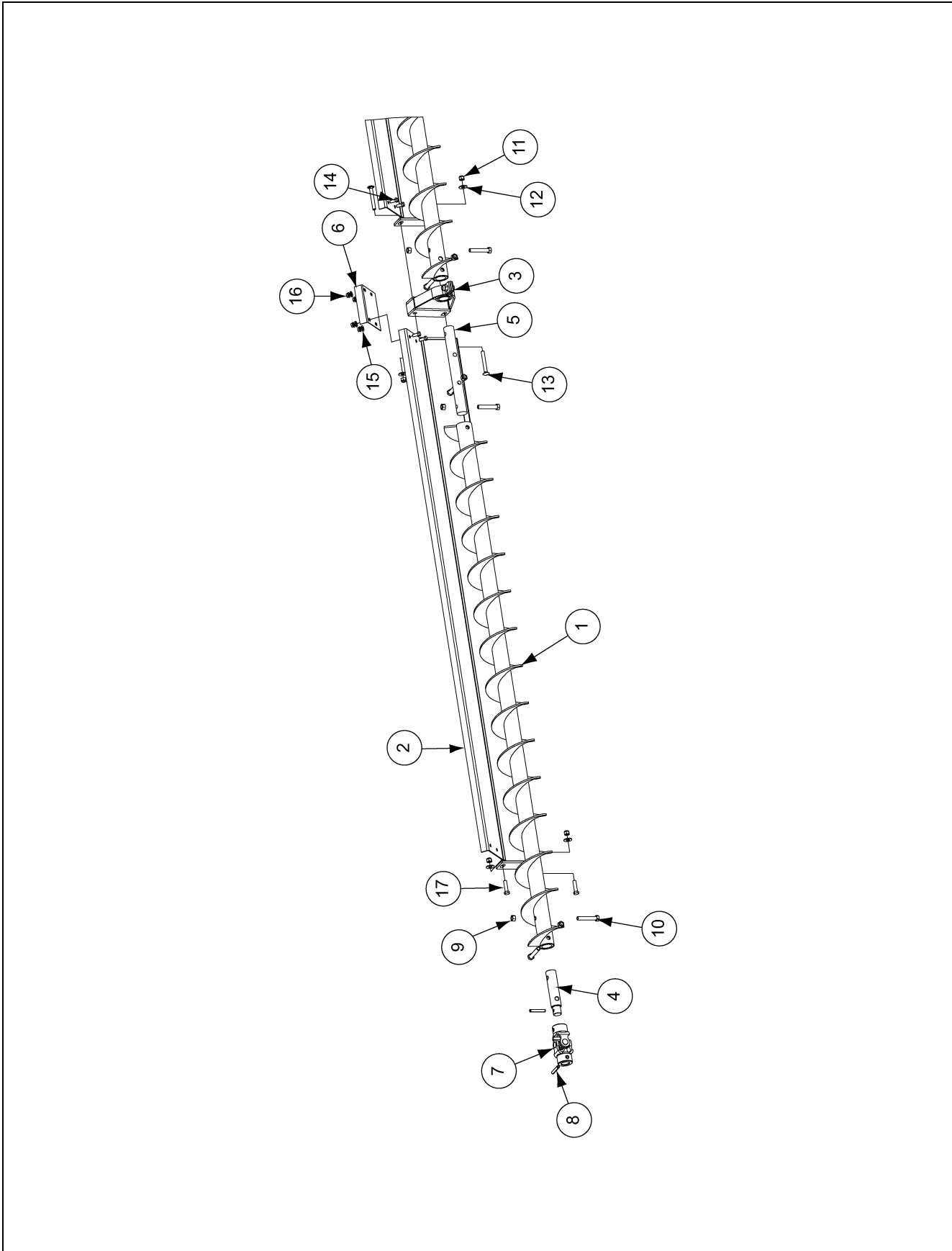

6" Flight and Shield Parts

Bundle #	Ref #	Part #	Description
GK6180	1	GK6178	6" x 4'-4" Flight Weldment
	2	GK5605	6" x 4'-4" Shield Assembly
GK6181	1	GK5932	6" x 5'-6" Flight Weldment
	2	GK5687	6" x 5'-6" Shield Assembly
GK5017	1	GK2134	6" x 5'-10" Flight Weldment
	2	GK4537	6" x 5'-10" Shield Assembly
GK6182	1	GK5933	6" x 7'-0" Flight Weldment
	2	GK5688	6" x 7'-0" Shield Assembly
GK6183	1	GK6179	6" x 7'-4" Flight Weldment
	2	GK5606	6" x 7'-4" Shield Assembly
GK6184	1	GK5934	6" x 8'-6" Flight Weldment
	2	GK5689	6" x 8'-6" Shield Assembly
GK5018	1	GK2129	6" x 8'-10" Flight Weldment
	2	GK4538	6" x 8'-10" Shield Assembly
	3	GK2107	Hanger Bearing Bracket
	4	GK1678	6" U-Joint Stub Shaft
	5	GK1736	6" Connecting Shaft
	6	GK5615	Shield Splice Plate
	7	GK1266	U-Joint 1" Bore
	8	S-4377	5/16" x 2" Grooved Roll Pin
	9	S-8317	7/16"-14 Stover Nut Zinc Grade C
	10	S-7372	7/16"-14 x 2-1/2" HHCS Bolt Zinc Grade 8
	11	S-7383	3/8" Nylock Lock Nut Zinc Grade 5
	12	S-248	3/8" Flat Washer Zinc
	13	S-8055	3/8"-16 x 3" Carriage Bolt Zinc Grade 5
	14	S-4275	5/16"-18 x 3/4" HHTB Bolt Zinc Grade 5
	15	S-1937	5/16" Flat Washer Zinc
	16	S-3611	5/16"-18 Serrated Flange Nut Zinc
	17	S-2086	3/8"-16 X 1-1/2" HHCS Bolt Zinc Grade 8

8" and 10" Flight and Shield Parts

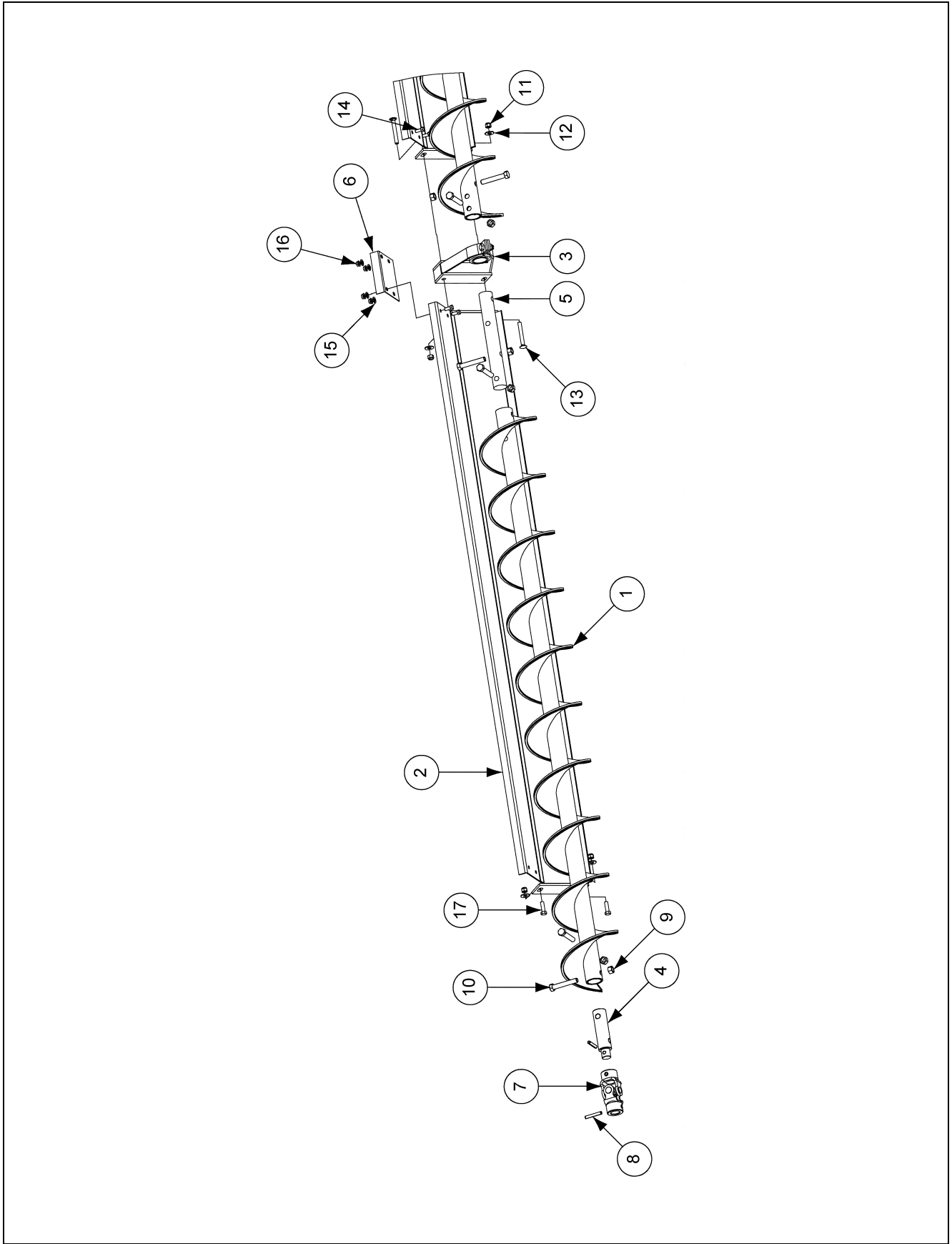

8" and 10" Flight and Shield Parts

Bundle #	Ref #	Part #	Description
GK6180	1	GK5911	8"/10" x 4'-4" Flight Weldment
	2	GK5757	8"/10" x 4'-4" Shield Assembly
GK6181	1	GK5912	8"/10" x 5'-6" Flight Weldment
	2	GK5690	8"/10" x 5'-6" Shield Assembly
GK5017	1	GK2080	8"/10" x 5'-10" Flight Weldment
	2	GK4740	8"/10" x 5'-10" Shield Assembly
GK6182	1	GK5913	8"/10" x 7'-0" Flight Weldment
	2	GK5691	8"/10" x 7'-0" Shield Assembly
GK6183	1	GK5914	8"/10" x 7'-4" Flight Weldment
	2	GK5756	8"/10" x 7'-4" Shield Assembly
GK6184	1	GK5915	8"/10" x 8'-6" Flight Weldment
	2	GK5692	8"/10" x 8'-6" Shield Assembly
GK5018	1	GK2074	8"/10" x 8'-10" Flight Weldment
	2	GK4745	8"/10" x 8'-10" Shield Assembly
	3	GK1954	Hanger Bearing Bracket
	4	GK5929	8"/10" U-Joint Stub Shaft
	5	GK1951	8"/10" Connecting Shaft
	6	GK5615	Shield Splice Plate
	7	GK1266	U-Joint 1" Bore
	8	S-4377	5/16" x 2" Grooved Roll Pin
	9	S-8315	1/2"-13 Stover Nut Zinc Grade C
	10	S-8252	1/2"-13 x 3" HHCS Bolt Zinc Grade 8
	11	S-7383	3/8" Nylock Lock Nut Zinc Grade 5
	12	S-248	3/8" Flat Washer Zinc
	13	S-8055	3/8"-16 x 3" Carriage Bolt Zinc Grade 5
	14	S-4275	5/16"-18 x 3/4" HHTB Bolt Zinc Grade 5
	15	S-1937	5/16" Flat Washer Zinc
	16	S-3611	5/16"-18 Serrated Flange Nut Zinc
	17	S-2086	3/8"-16 X 1-1/2" HHCS Bolt Zinc Grade 8

Reduction Wheel Parts

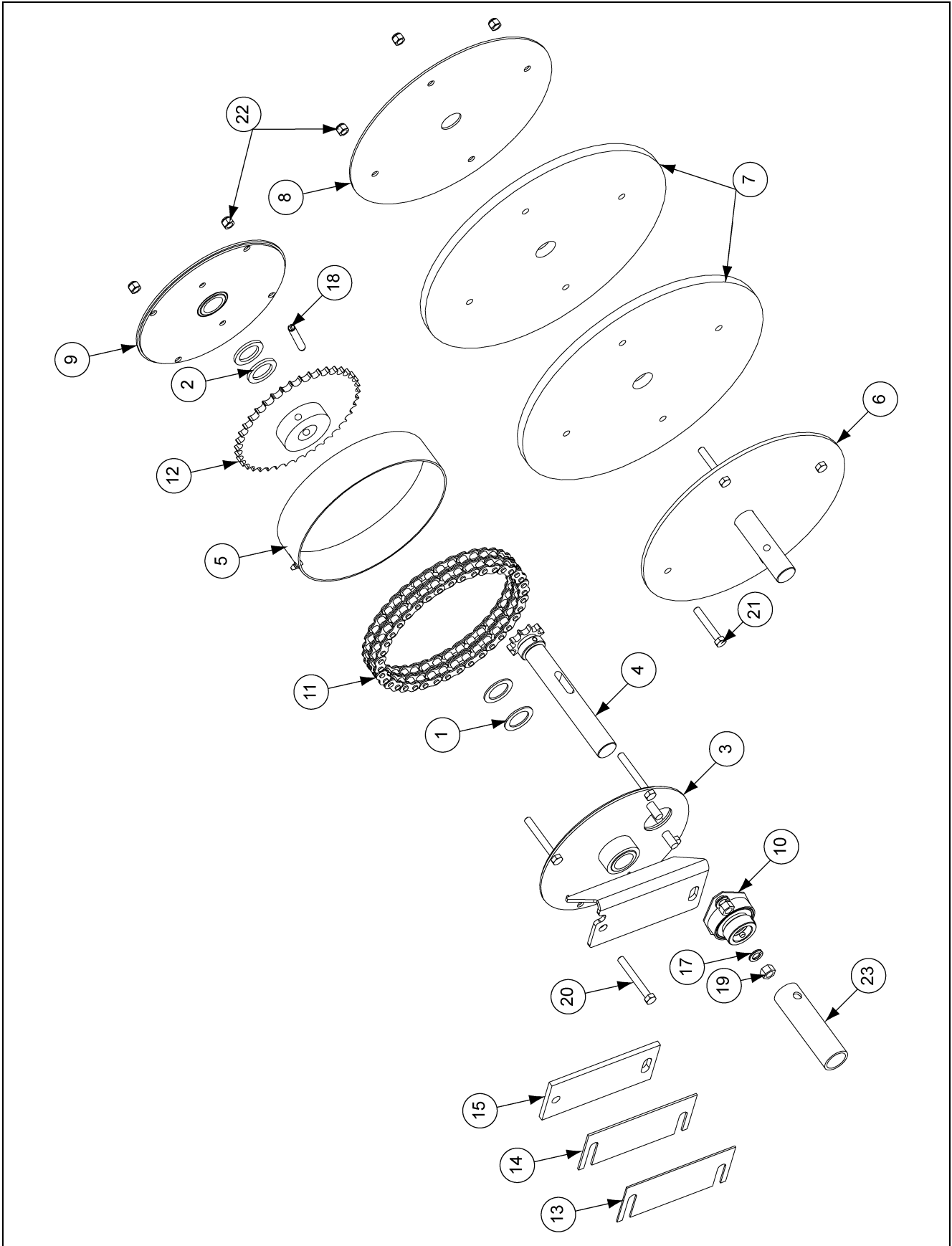

Reduction Wheel Parts

Ref #	Part #	Description
1	GK4210	1" x 1-1/2" 14 Gauge Galvanized Flat Washer
2	GK4211	1" x 1-1/2" 10 Gauge Galvanized Flat Washer
3	GK4213	Inner Drive Housing with Bushing; 6"
	GK4228	Inner Drive Housing with Bushing; 8"/10"
4	GK6526	Drive Shaft with Sprocket and Roll Pin
5	GK4215	Housing Ring with Zerk
6	GK4217	Inner Wheel Weldment; 6"
	GK4242	Inner Wheel Weldment; 8"/10"
7	GK4218	Rubber Wheel Disk 11" O.D.; 6"
	GK4241	Rubber Wheel Disk 11" O.D.; 8"/10"
8	GK4219	Outer Wheel Disk; 6"
	GK4240	Outer Wheel Disk; 8"/10"
9	GK4223	Outer Drive Housing with Bushing
10	GK4232	1" Bearing with 2 Hole Flange
11	GK4233	Chain Roller #40 Double with Link
12	GK4234	40 Tooth Sprocket with Hub
13	GK4209	14 Gauge Spacer Plate; 6"
	GK4226	14 Gauge Spacer Plate; 8"/10"
14	GK4208	12 Gauge Spacer Plate; 6"
	GK4225	12 Gauge Spacer Plate; 8"/10"
15	GK4207	1/4" Spacer Plate; 6"
	GK4224	1/4" Spacer Plate; 8"/10"
16	GK4205	1" I.D. x 1-1/4" O.D. x 4-3/8" Long Bushing; 6"
	GK4206	1" I.D. x 1-1/2" O.D. x 4-3/8" Long Bushing; 8"/10"
17	S-1054	3/8" Zinc Split Washer
18	S-4383	5/16" x 2-1/4" Rolled Pin Spring
19	S-456	3/8" Zinc YDP Grade 5 Hex Nut
20	S-7075	5/16"-18 x 2-1/2" HHCS Bolt Grade 5 Zinc
21	S-7329	5/16"-18 x 2" HHCS Bolt Grade 2 Zinc
22	S-7382	5/16"-18 Nylock Nut Grade 5 Zinc

6" Bin Flange Parts

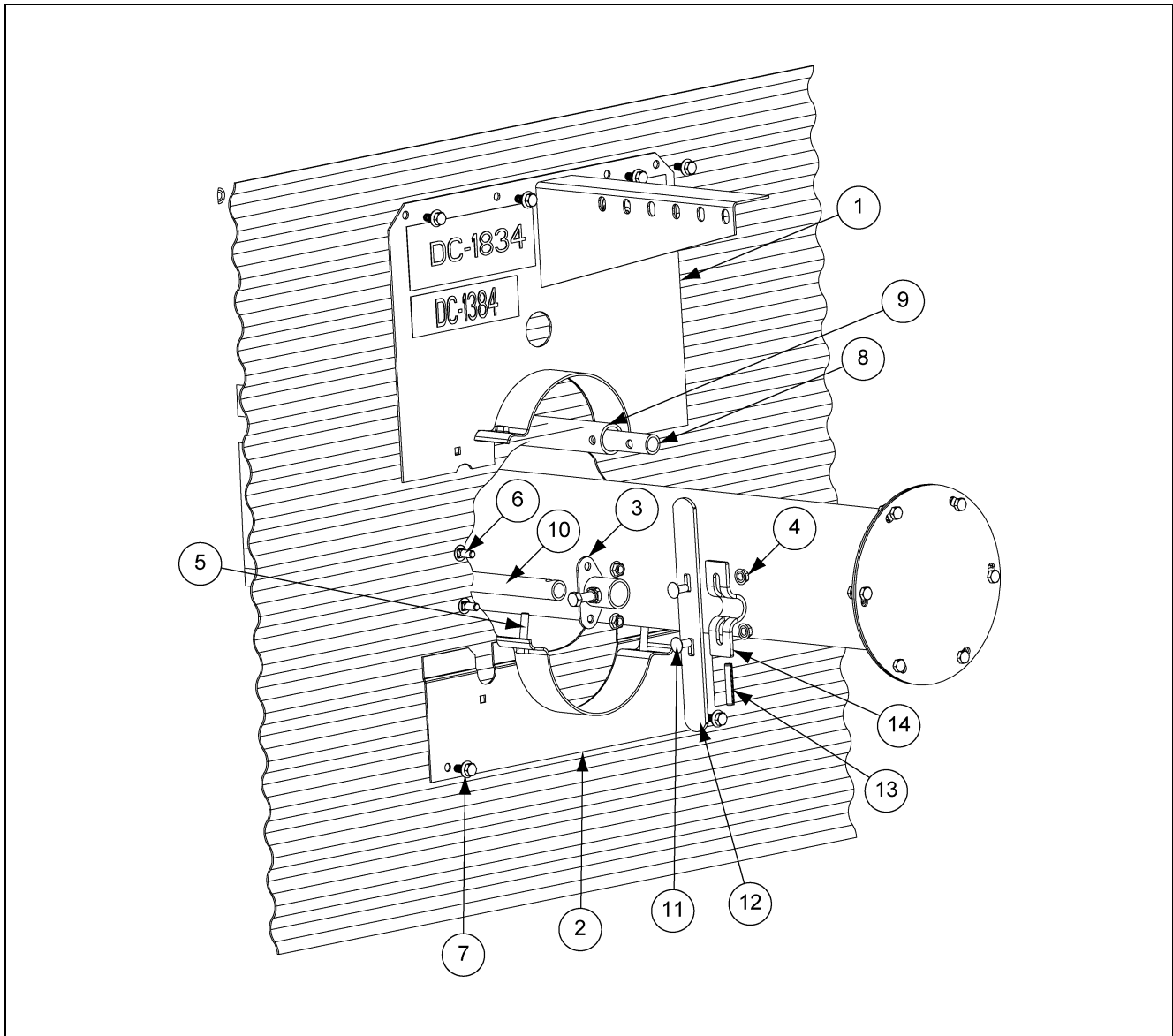

6" Bin Flange Parts

Ref #	Part #	Description
1	GC10546	6" Top Bin Flange
2	GC10547	6" Bottom Bin Flange
3	GK1619	Clutch Flange
4	S-3611	5/16"-18 Serrated Flange Nut Zinc
5	S-2741	5/16"-18 x 1-1/2" HHCS Bolt Zinc Grade 8
6	S-6076	5/16"-18 x 3/4" Carriage Bolt Zinc Grade 2
7	S-275	5/16"-18 x 3/4" HHBIN Bolt Grade 5

Ref #	Part #	Description
8		<i>See Page 67</i>
9		
10		
11	S-6076	5/16"-18 x 3/4" Carriage Bolt Zinc Grade 2
12	GC01192	Control Pipe Handle
13	S-8397	5/16" x 1-3/4" Spring Pin
14	GK1726	Control Pipe Clamp

8" Bin Flange Parts

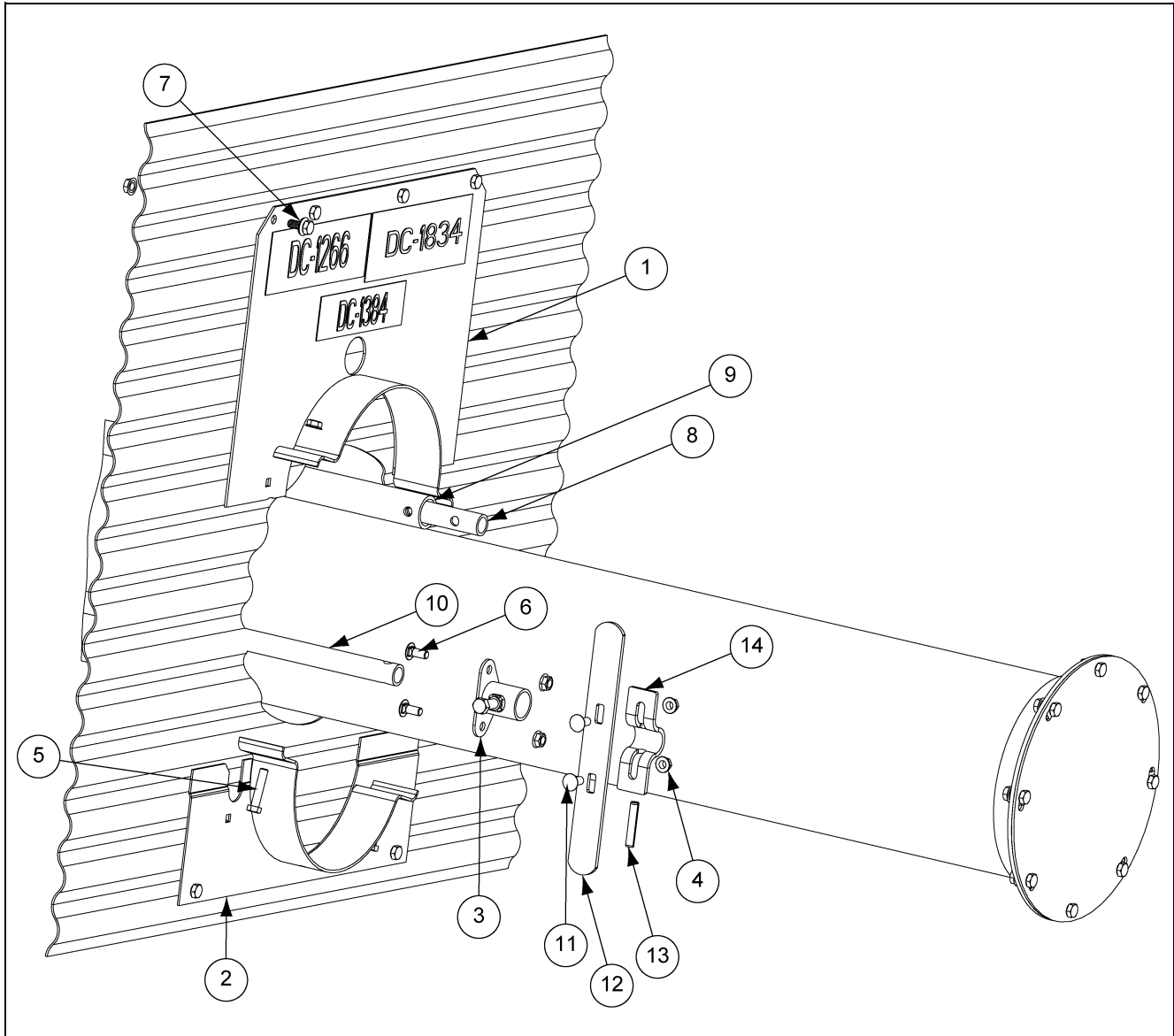

8" Bin Flange Parts

Ref #	Part #	Description
1	GC10534	8" Top Bin Flange
2	GC10536	8" Bottom Bin Flange
3	GK1619	Clutch Flange
4	S-3611	5/16"-18 Serrated Flange Nut Zinc
5	S-2741	5/16"-18 x 1-1/2" HHCS Bolt Zinc Grade 8
6	S-6076	5/16"-18 x 3/4" Carriage Bolt Zinc Grade 2
7	S-275	5/16"-18 x 3/4" HHBIN Bolt Grade 5

Ref #	Part #	Description
8	<i>See Page 67</i>	
9		
10		
11	S-6076	5/16"-18 x 3/4" Carriage Bolt Zinc Grade 2
12	GC01192	Control Pipe Handle
13	S-8397	5/16" x 1-3/4" Spring Pin
14	GK1726	Control Pipe Clamp

10" Bin Flange Parts

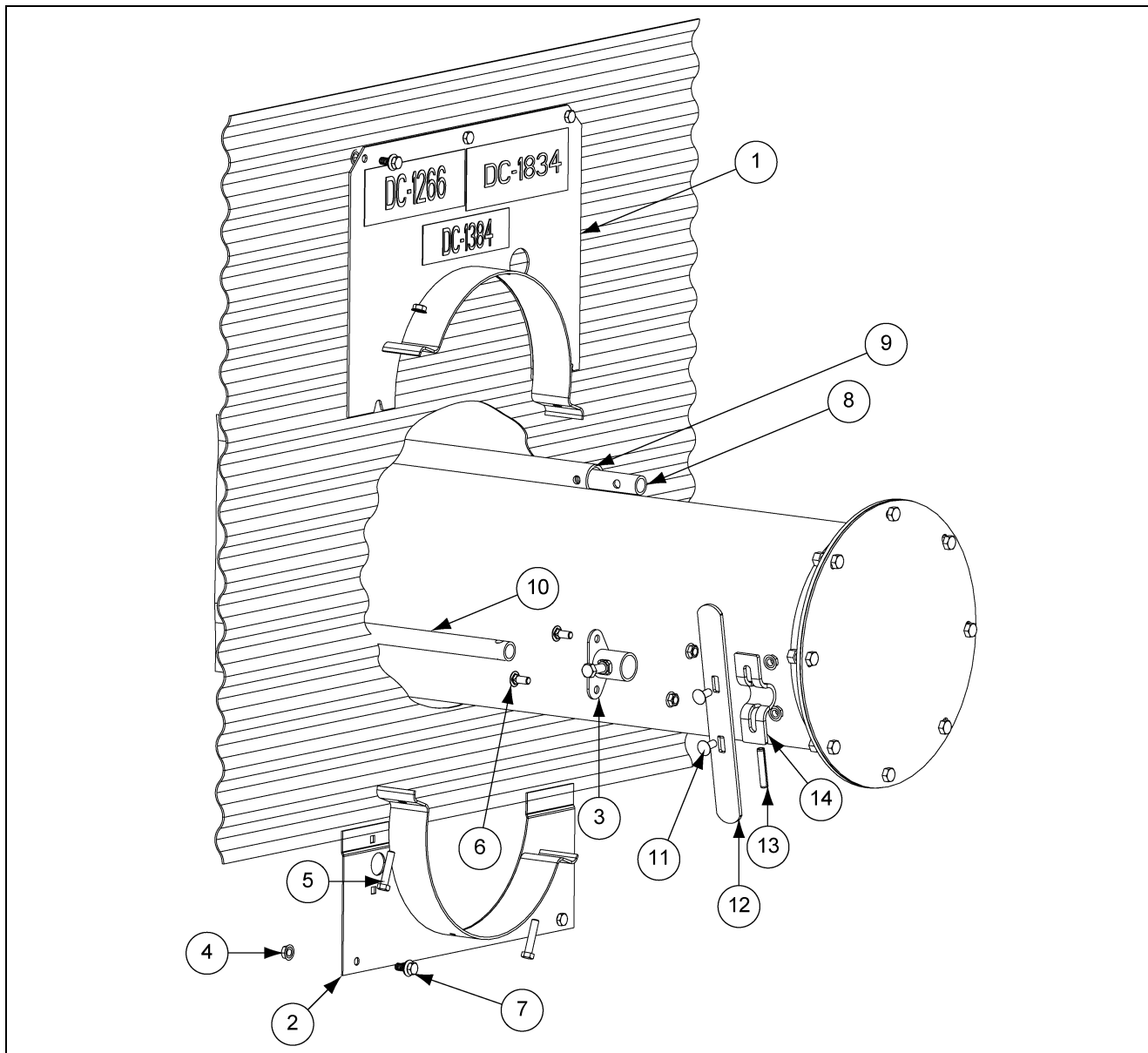

10" Bin Flange Parts

Ref #	Part #	Description
1	GC10560	10" Top Bin Flange
2	GC10558	10" Bottom Bin Flange
3	GK1619	Clutch Flange
4	S-3611	5/16"-18 Serrated Flange Nut Zinc
5	S-2741	5/16"-18 x 1-1/2" HHCS Bolt Zinc Grade 8
6	S-6076	5/16"-18 x 3/4" Carriage Bolt Zinc Grade 2
7	S-275	5/16"-18 x 3/4" HHBIN Bolt Grade 5

Ref #	Part #	Description
8		<i>See Page 67</i>
9		
10		
11	S-6076	5/16"-18 x 3/4" Carriage Bolt Zinc Grade 2
12	GC01192	Control Pipe Handle
13	S-8397	5/16" x 1-3/4" Spring Pin
14	GK1726	Control Pipe Clamp

6", 8" and 10" Bin Flange Parts

Control Pipe

NOTE: All two piece pipes assemble with GC05323; 3/8" NPT x 1.0" pipe connector

Bin Size	Center Well Control Pipe (8)		Intermediate Well Control Pipe (9)			Clutch Control Pipe (10)	
	Part #	Description	6" Part #	8" or 10" Part #	Description	Part #	Description
15'	GC09110	.840" O.D. x 7'	GC10360	GC11114	1" O.D. x 5' 1.851"	GK1709	.840" O.D. x 10'
18'	GC09111	.840" O.D. x 8' 6"	GC10359	GC11115	1" O.D. x 6' 10.475"	GK1720	.840" O.D. x 11' 6"
21'	GC09112	.840" O.D. x 10'	GC10358	GC11117	1" O.D. x 8' 6.824"	GK1730	.840" O.D. x 13'
24'	GC09113	.840" O.D. x 11' 6"	GC10357	GC11118	1" O.D. x 9' 8.726"	GK1744	.840" O.D. x 14' 6"
27'	GC09114	.840" O.D. x 13'	GC10356	GC11119	1" O.D. x 10' 8.726"	GK1749	.840" O.D. x 16'
30'	GC09115	.840" O.D. x 14' 6"	GC10355	GC11120	1" O.D. x 11' 8.726"	GK1754	.840" O.D. x 17' 6"
33'	GC09116	.840" O.D. x 16'	G10354	GC11121	1" O.D. x 14' 1.664"	GK1761	.840" O.D. x 19' 6"
36'	GC09117	.840" O.D. x 17' 6"	GC10353	GC11122	1" O.D. x 515' 4.664"	GK1769	.840" O.D. x 20' 6"
39'	GC09118	.840" O.D. x 19'	-	GC11123	1" O.D. x 16' 6.164"	GK1766	.840" O.D. x 1'
						GK1776	.840" O.D. x 21'
42'	GC09119	.840" O.D. x 20' 6"	-	GC11124	1" O.D. x 18' 8.226"	GK1784	.840" O.D. x 2' 6"
						GK1776	.840" O.D. x 21'
48'	GK1776	.840" O.D. x 21'	-	GC11125	1" O.D. x 21'	GK1719	.840" O.D. x 8' 6"
	GC09075	.840" O.D. x 2' 6"				GK1776	.840" O.D. x 21'

NOTES

The GSI Group Warranty

THE GSI GROUP (GSI) WARRANTS ALL PRODUCTS WHICH IT MANUFACTURES TO BE FREE OF DEFECTS IN MATERIAL AND WORKMANSHIP UNDER NORMAL USAGE AND CONDITIONS FOR A PERIOD OF 12 MONTHS AFTER RETAIL SALE TO THE ORIGINAL END USER. THE PURCHASER'S SOLE REMEDY AND GSI'S ONLY OBLIGATION SHALL BE TO REPAIR OR REPLACE, AT GSI'S OPTION AND EXPENSE, PRODUCTS THAT, IN GSI'S SOLE JUDGMENT, CONTAIN A MATERIAL DEFECT DUE TO MATERIALS OR WORKMANSHIP. ALL DELIVERY AND SHIPMENT CHARGES TO AND FROM GSI'S FACTORY WILL BE PURCHASER'S RESPONSIBILITY. EXPENSES INCURRED BY OR ON BEHALF OF THE PURCHASER WITHOUT PRIOR WRITTEN AUTHORIZATION FROM AN AUTHORIZED EMPLOYEE OF GSI SHALL BE THE SOLE RESPONSIBILITY OF THE PURCHASER.

EXCEPT FOR THE LIMITED WARRANTY EXPRESSED ABOVE, GSI MAKES NO FURTHER WARRANTY OF ANY KIND, EXPRESS OR IMPLIED, INCLUDING, WITHOUT LIMITATION, WARRANTIES OF MERCHANTABILITY OR FITNESS FOR A PARTICULAR PURPOSE OR USE IN CONNECTION WITH (I) PRODUCT MANUFACTURED OR SOLD BY GSI OR (II) ANY ADVICE, INSTRUCTION, RECOMMENDATION OR SUGGESTION PROVIDED BY AN AGENT, REPRESENTATIVE OR EMPLOYEE OF GSI REGARDING OR RELATED TO THE CONFIGURATION, INSTALLATION, LAYOUT, SUITABILITY FOR A PARTICULAR PURPOSE, OR DESIGN OF SUCH PRODUCTS.

GSI SHALL NOT BE LIABLE FOR ANY DIRECT, INDIRECT, INCIDENTAL OR CONSEQUENTIAL DAMAGES, INCLUDING, WITHOUT LIMITATION, LOSS OF ANTICIPATED PROFITS OR BENEFITS. PURCHASER'S SOLE AND EXCLUSIVE REMEDY IS AS SET FORTH IN THE LIMITED WARRANTY EXPRESSED ABOVE, WHICH SHALL NOT EXCEED THE AMOUNT PAID FOR THE PRODUCT PURCHASED. THIS WARRANTY IS NOT TRANSFERABLE AND APPLIES ONLY TO THE ORIGINAL PURCHASER. GSI SHALL HAVE NO OBLIGATION OR RESPONSIBILITY FOR ANY REPRESENTATIONS OR WARRANTIES MADE BY OR ON BEHALF OF ANY DEALER, AGENT OR DISTRIBUTOR OF GSI.

GSI ASSUMES NO RESPONSIBILITY FOR CLAIMS RESULTING FROM ERECTION DEFECTS OR UNAUTHORIZED MODIFICATIONS TO PRODUCTS WHICH IT MANUFACTURED. MODIFICATIONS TO PRODUCTS NOT SPECIFICALLY DELINEATED IN THE MANUAL ACCOMPANYING THE EQUIPMENT AT INITIAL SALE WILL NULLIFY THE PRODUCT WARRANTY THAT MIGHT HAVE BEEN OTHERWISE AVAILABLE.

THE FOREGOING WARRANTY SHALL NOT EXTEND TO PRODUCTS OR PARTS WHICH HAVE BEEN DAMAGED BY NEGLIGENT USE, MISUSE, ALTERATION OR ACCIDENT. THIS WARRANTY EXTENDS SOLELY TO ONLY PRODUCTS MANUFACTURED BY GSI. THIS WARRANTY IS EXCLUSIVE AND IN LIEU OF ALL OTHER WARRANTIES EXPRESS OR IMPLIED. GSI RESERVES THE RIGHT TO MAKE DESIGN OR SPECIFICATION CHANGES AT ANY TIME.

PRIOR TO INSTALLATION, PURCHASER HAS THE RESPONSIBILITY TO COMPLY WITH ALL FEDERAL, STATE AND LOCAL CODES WHICH MAY APPLY TO THE LOCATION AND INSTALLATION OF PRODUCTS MANUFACTURED OR SOLD BY GSI.

This equipment shall be installed in accordance with the current installation codes and applicable regulations which should be carefully followed in all cases. Authorities having jurisdiction should be consulted before installations are made.

G S I G R O U P



GSI Group
1004 E. Illinois St.
Assumption, IL 62510-0020
Phone: 1-217-226-4421
Fax: 1-217-226-4420
www.gsiag.com