

CE Compliant Direct Gear Drive Bin Sweep Auger (with Roller Wells)

Assembly and Operation Manual -
Original Instructions

PNEG-1421CE

Date: 09-10-13

GSI GROUP



PNEG-1421CE



**CE Declaration of Incorporation
MACHINERY DIRECTIVE
2006/42/EC**

1004 East Illinois Street, Assumption, IL, 62510, USA

+1 217 226 4429

The GSI Group declares that the machine, parts or equipment.

Bin Power Sweep Augers

Models

Bin Diameter	6" DGD Sweep	8" DGD Sweep	10" DGD Sweep
15'	GPS61503	GPS81503	-
18'	GPS61803	GPS81803	-
21'	GPS62103	GPS82103	-
24'	GPS62403	GPS82403	GPS10242
27'	GPS62703	GPS82703	GPS10272
30'	GPS63003	GPS83003	GPS10302
33'	GPS63303	GPS83303	GPS10332
36'	GPS63603	GPS83603	GPS10362
39'	-	GPS83903	GPS10392
42'	-	GPS84203	GPS10422
48'	-	GPS84803	GPS10482

EXCLUDING

- **Low profile centre and intermediate floor wells.**

Meet the following clauses of the Essential Requirements of the Machinery Directive 2006/42/EC.

- 1.1.2 and sub-clauses principles of safety integration
- 1.3.1 Risk of loss of stability
- 1.3.2 Risk of break-up during operation
- 1.3.7 Risk related to moving parts
- 1.3.8 Choice of protection against risks arising from moving parts
 - 1.3.8.1 Moving transmission parts
- 1.3.9 Risks of uncontrolled movements
- 1.4 Required characteristics of guards and protective devices
 - 1.4.1 General requirements
 - 1.4.2 Special requirements for guards
 - 1.4.2.1 Fixed guards
- 1.5.4 Errors of fitting
- 1.5.5 Extreme temperatures



1004 East Illinois Street, Assumption, IL, 62510, USA

+1 217 226 4429

- 1.5.6 Fire
- 1.5.7 Explosion
- 1.5.8 Noise
- 1.5.9 Vibrations
- 1.5.13 Emissions of hazardous materials and substances
- 1.6 Maintenance
 - 1.6.1 Machinery maintenance
 - 1.6.4 Operator intervention
- 1.7 Information
 - 1.7.1 Information and warnings on the machinery
 - 1.7.1.1 Information and information devices
 - 1.7.2 Warning of residual risks
 - 1.7.4. Instructions
 - 1.7.4.1 General principles for the drafting of instructions
 - 1.7.4.2 Contents of the instructions but not inclusive of sub-clause (u)
 - 1.7.4.3 Sales literature

This declaration applies only to the mechanical elements of the above machines and does not imply conformity by any other items of equipment fitted to or connected with the above machines. The equipment above must not be put into service until the machinery into which it is to be incorporated has been declared in conformity with the provisions of all relevant Directives, nor until these components have been assembled in the manner recommended in the attached manufacturers instructions.

Signed :

Name:

Position: Frank Ward Director Hennock International Limited On behalf The GSI Group

Date:

NOTES

Contents

Chapter 1 Introduction	7
Chapter 2 Safety	8
Safety Guidelines	8
Safety Instructions	9
Possible Hazards Inside Grain Bins	11
Minimum Auger Safety Requirements	12
Chapter 3 Safety Decals	14
International Decals	14
Chapter 4 Installation	16
Power Sweep in Bins with Concrete Floors	16
Power Sweeps in Bins with Raised Metal Floors	17
Intermediate Well Installation	18
Unload Tube Installation	19
Install Bin Flange	21
Center Well Slide Gate Assembly	23
Control Lever Installation (6" Systems)	24
Rack and Pinion Installation (8" and 10" Systems)	25
Clutch Control Installation	27
Installing the Unload Tube Flight	29
Install the Sweep Flighting	30
Install the Flighting Shield	34
Sweep Wheel Installation	36
Chapter 5 Electrical Installation	37
Motor Requirements	37
Electrical Control System	37
Setting Clutch Control	40
Chapter 6 Operation	41
Power Recommendations	41
Perform Pre-Start Checks	42
Operation	42
Engaging the Clutch for Bin Sweep	46
Final Clean Out	47
Chapter 7 Shut Down	48
Normal Shut Down	48
Emergency Shut Down	48
Storage Preparation	48
Chapter 8 Maintenance	49
Maintaining the Auger	49

Table of Contents

Chapter 9 Parts List	51
Center Well Parts	52
Shaft Assembly	54
Center Connection Parts	55
6" Intermediate Well Parts	56
8" Intermediate Well Parts	58
10" Intermediate Well Parts	60
6" Bin Flange Parts	62
8" Bin Flange Parts	63
10" Bin Flange Parts	64
6" Well Gate Control Parts	66
8" and 10" Rack and Pinion	68
Assembled Sweep Arm Components	70
6", 8" and 10" Flight and Shield Bundle	72
Spacer Plates for Reduction Drive Wheel	73
Reduction Wheel Drive Components	74
Chapter 10 Troubleshooting	76
Chapter 11 Warranty	77

READ THIS MANUAL carefully to learn how to properly use and install equipment. Failure to do so could result in personal injury or equipment damage.

INSPECT the shipment immediately upon arrival. The customer is responsible for ensuring that all quantities are correct. The customer should report and note any damage or shortage on the bill of lading to justify their claim to the transport company.

THIS MANUAL SHOULD BE CONSIDERED a permanent part of your equipment and should be easily accessible when needed.

This warranty provides you the assurance that the company will back its products when defects appear within the warranty period. In some circumstances, the company also provides field improvements, often without charge to the customer, even if the product is out of warranty. Should the equipment be abused, or modified to change its performance beyond the factory specifications, the warranty will become void and field improvements may be denied.

Safety Guidelines

This manual contains information that is important for you, the owner/operator, to know and understand. This information relates to protecting **personal safety** and **preventing equipment problems**. It is the responsibility of the owner/operator to inform anyone operating or working in the area of this equipment of these safety guidelines. To help you recognize this information, we use the symbols that are defined below. Please read the manual and pay attention to these sections. Failure to read this manual and its safety instructions is a misuse of the equipment and may lead to serious injury or death.



This is the safety alert symbol. It is used to alert you to potential personal injury hazards. Obey all safety messages that follow this symbol to avoid possible injury or death.



DANGER indicates a hazardous situation which, if not avoided, will result in death or serious injury.



WARNING indicates a hazardous situation which, if not avoided, could result in death or serious injury.



CAUTION, used with the safety alert symbol, indicates a hazardous situation which, if not avoided, could result in minor or moderate injury.



NOTICE is used to address practices not related to personal injury.

Safety Instructions

Our foremost concern is your safety and the safety of others associated with this equipment. We want to keep you as a customer. This manual is to help you understand safe operating procedures and some problems that may be encountered by the operator and other personnel.

As owner and/or operator, it is your responsibility to know what requirements, hazards, and precautions exist, and to inform all personnel associated with the equipment or in the area. Safety precautions may be required from the personnel. Avoid any alterations to the equipment. Such alterations may produce a very dangerous situation where **SERIOUS INJURY** or **DEATH** may occur.

This equipment shall be installed in accordance with the current installation codes and applicable regulations, which should be carefully followed in all cases. Authorities having jurisdiction should be consulted before installations are made.

Follow Safety Instructions

Carefully read all safety messages in this manual and safety signs on your machine. Keep signs in good condition. Replace missing or damaged safety signs. Be sure new equipment components and repair parts include the current safety signs. Replacement safety signs are available from the manufacturer.

Learn how to operate the machine and how to use controls properly. Do not let anyone operate without instruction.

Keep your machinery in proper working condition. Unauthorized modifications to the machine may impair the function and/or safety and affect machine life.

If you do not understand any part of this manual or need assistance, contact your dealer.

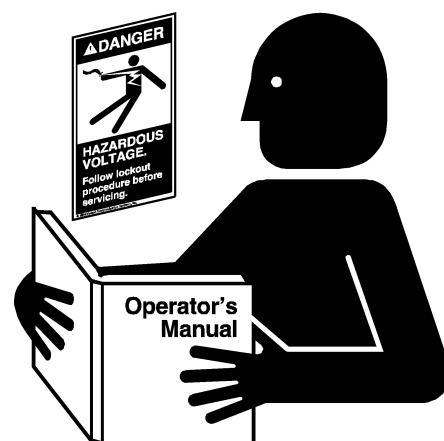

Read and Understand Manual

Prepare for Emergencies

Be prepared if fire starts.

Keep a first aid kit and fire extinguisher handy.

Keep emergency numbers for doctors, ambulance service, hospital, and fire department near your telephone.

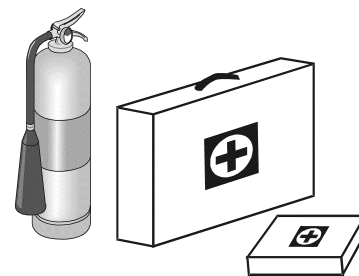

Keep Emergency Equipment Quickly Accessible

2. Safety

Wear Protective Clothing

Wear close-fitting clothing and safety equipment appropriate to the job.

Remove all jewelry.

Tie long hair up and back.

Wear safety glasses at all times to protect eyes from debris.

Wear gloves to protect your hands from sharp edges on plastic or steel parts.

Wear steel-toed boots to help protect your feet from falling debris. Tuck in any loose or dangling shoestrings.

A respirator may be needed to prevent breathing potentially toxic fumes and dust.

Wear a hard hat to help protect your head.

Wear appropriate fall protection equipment when working at elevations greater than six feet (6').

Eye Protection

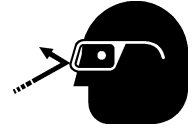

Gloves



Steel-Toed Boots



Respirator



Hard Hat



Fall Protection



Possible Hazards Inside Grain Bins

The inside of a grain bin, no matter what size, is a dangerous location. Grain bins should be kept **locked shut** at all times.



NEVER allow a child or untrained, inexperienced person to enter a grain bin.

Hazards present at any time may include:



Mass flow of grain when filling or emptying which could draw you in and cause suffocation/burial.



Bridged, crusted or capped grain which could collapse if you stand on it. It is recommended **NEVER** to walk on the surface of the stored material.

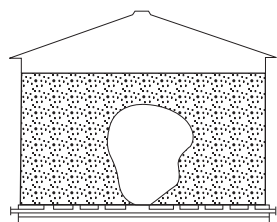
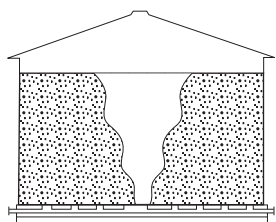

If grain has stopped flowing, become bridged, capped or crusted, the **only safe way** to remedy this is from the outside of the bin.



Exposed machinery such as fans, augers and conveyors with which you could become entangled.



Hazardous substances such as dust, mould spores, vapors and gases or low oxygen levels which could cause respiratory problems.



High temperature combustible material.



2. Safety

Minimum Auger Safety Requirements



Incorrect use of augers can be extremely dangerous. Rotating flights and shafts can cause serious injury and kill.

Correct Use

1. The auger is for the final process of emptying whole agricultural seeds and grains from inside a circular grain bin. Any other use is prohibited and may result in injury or equipment damage.
2. These sweep augers are to be permanently installed inside the grain bin and in are not designed to be portable.
3. The sweep auger can only be safely used inside a grain bin with no person inside the bin.
4. The installer and operator have responsibility to ensure the final installation is in accordance with all the safety requirements outlined in this manual and fulfils the Essential Requirements of the Machinery Directive 2006/42/EC.
5. Never use the auger with any guards removed.
6. Never enter the grain bin unless the power supply to the auger and all other equipment in the bin is OFF, TAGGED and LOCKED. (See Figure 2A.)

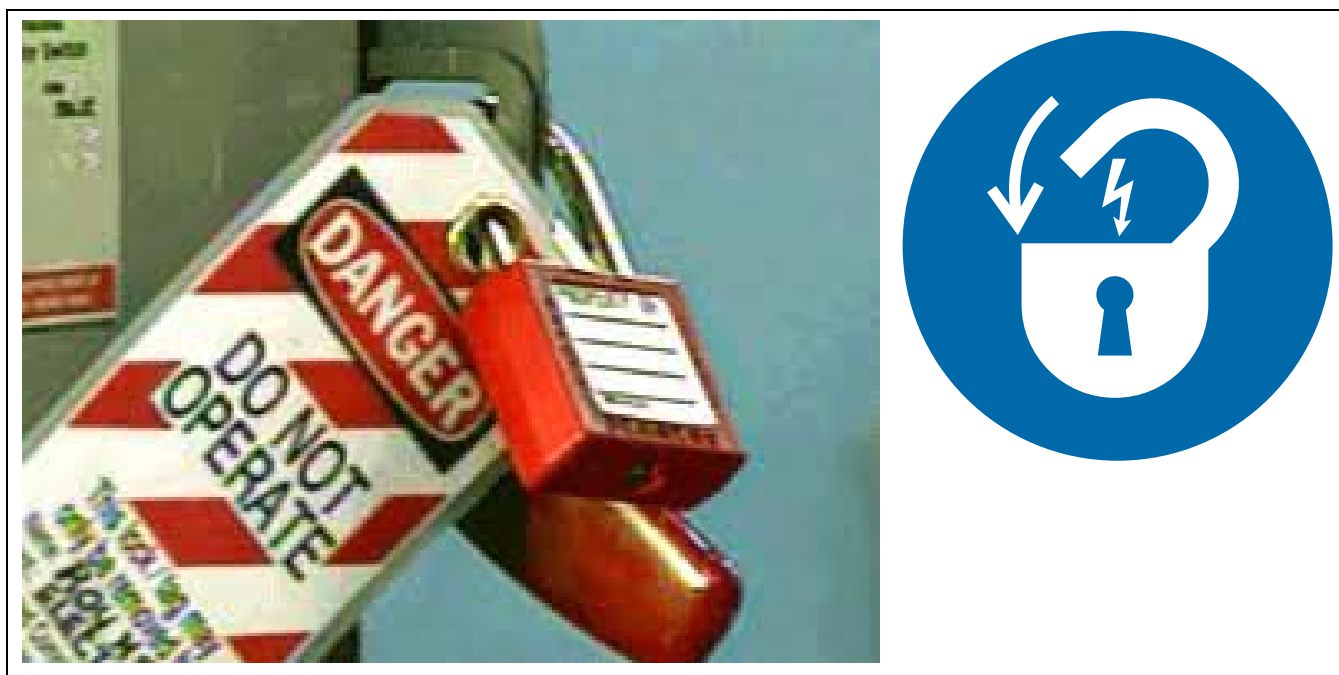

Figure 2A

7. Never leave the auger running unattended.
8. Always TURN OFF and LOCK the power supply to the auger before leaving it unattended.
9. Never allow an untrained person less or one less than 18 years old to operate the auger.
10. Never allow someone under the influence of alcohol or drugs to operate the equipment.

11. Never modify the auger from it's original specification.
12. Never work alone.
13. Never start equipment until all persons are clear of the grain bin.
14. Keep hands and feet away from the auger outlet and other moving parts.
15. Always think before acting. Never act impulsively around the equipment.
16. Never allow anyone inside a bin, truck or wagon which is being loaded or unloaded. Flowing grain can trap and suffocate in seconds.

Electrical Safety Equipment

Please refer to [Chapter 5 on Page 37](#) for electrical control requirements.

1. All electrical installation and design must be carried out by a qualified electrical engineer and in accordance with EU Directives and standards and in accordance with local laws and codes.
2. The electrical supply must include a properly designed protective earth system (PE).
3. The motor must be connected to protective earth at the terminal provided.
4. The control system must include short circuit protection.
5. It is recommended to provide earth leakage protection, such as Residual Current Device (RCD) or Residual Current Circuit Breaker (RCCB) to provide automatic disconnection from the power in the event of a fault.

3. Safety Decals

Below are the safety warning decals that should be fitted to the auger. These warn of residual risks and required safety measures and must remain intact, legible and undamaged for the life of the machine. If any decals have become damaged or unreadable, please contact GSI or your dealer for free replacements.

International Decals

International, translated versions of the decals fitted to the equipment are available as part of the language pack that was supplied with the product. If you need further copies or a different language, please contact GSI or you dealer.

The international decals have been designed to be placed directly over the USA standard versions. Normally these will be factory fitted, but if you need to change them, please refer to decal cross reference sheet, provided with the language pack and the decal locations given in the user's manual.

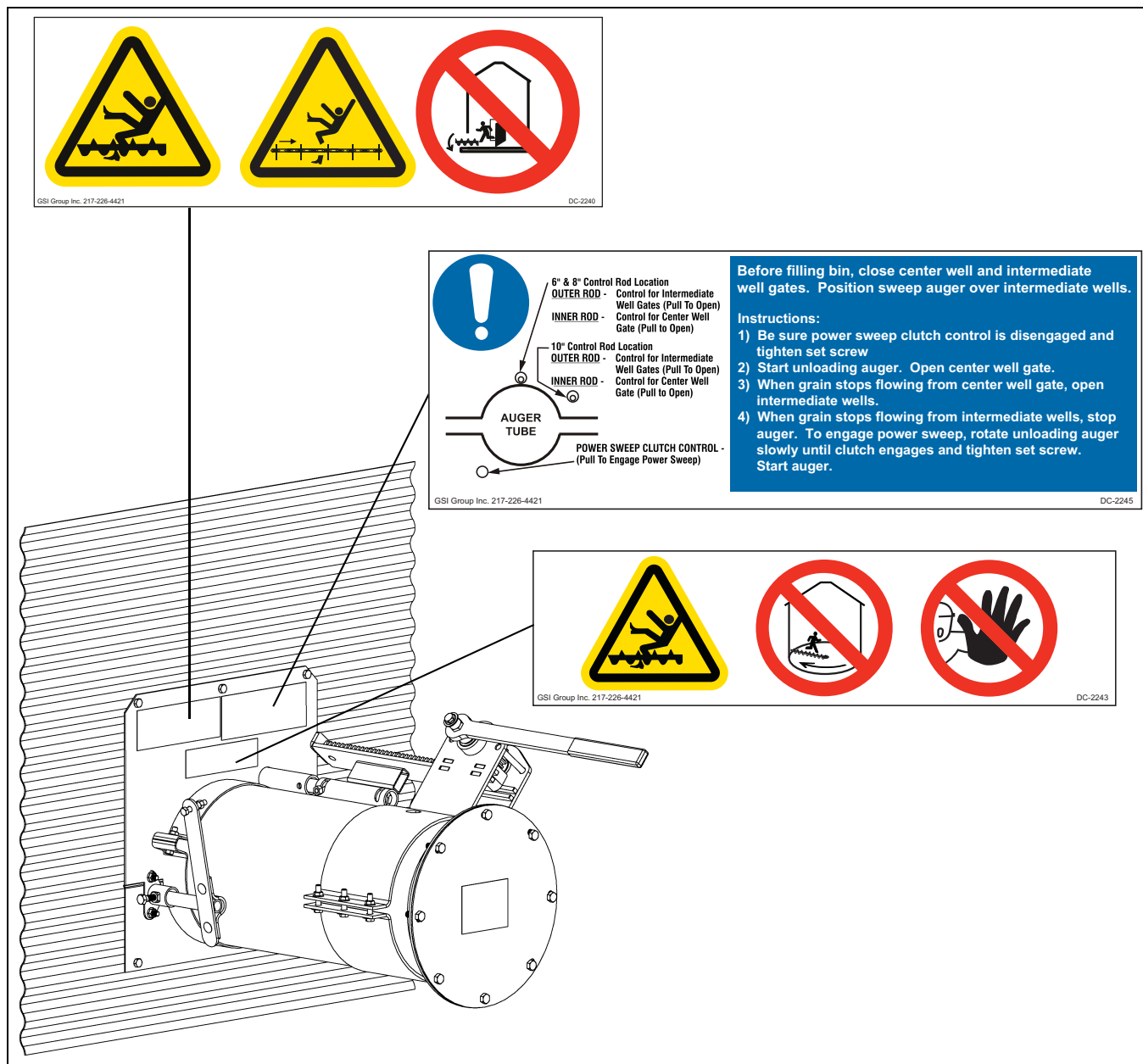

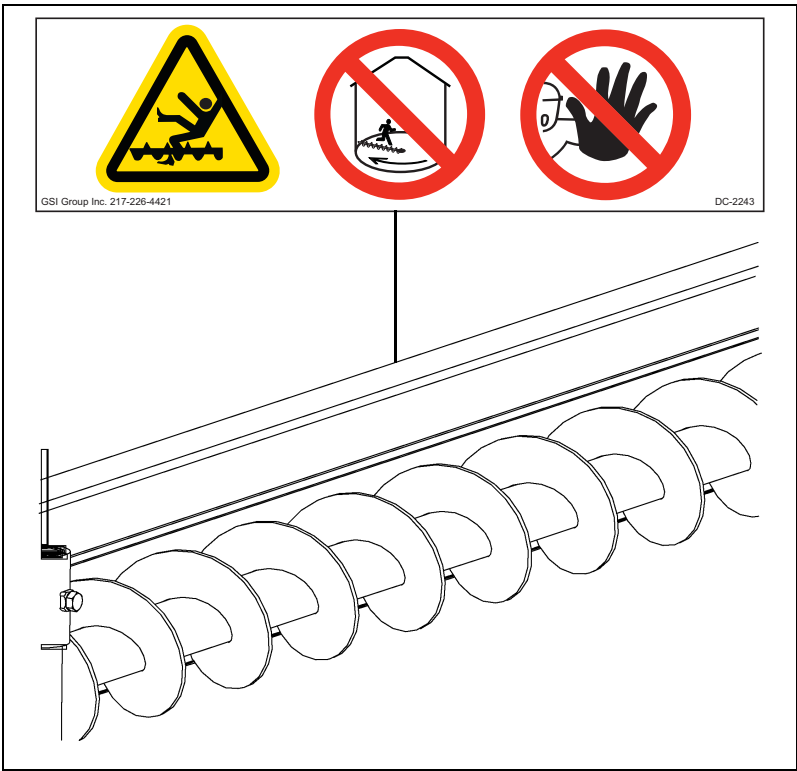

Figure 3B

DC-2244 Should be fitted to all bins where augers are installed. This should be located in clear view adjacent to all personnel entry points on the bin. (See Figure 3C.)

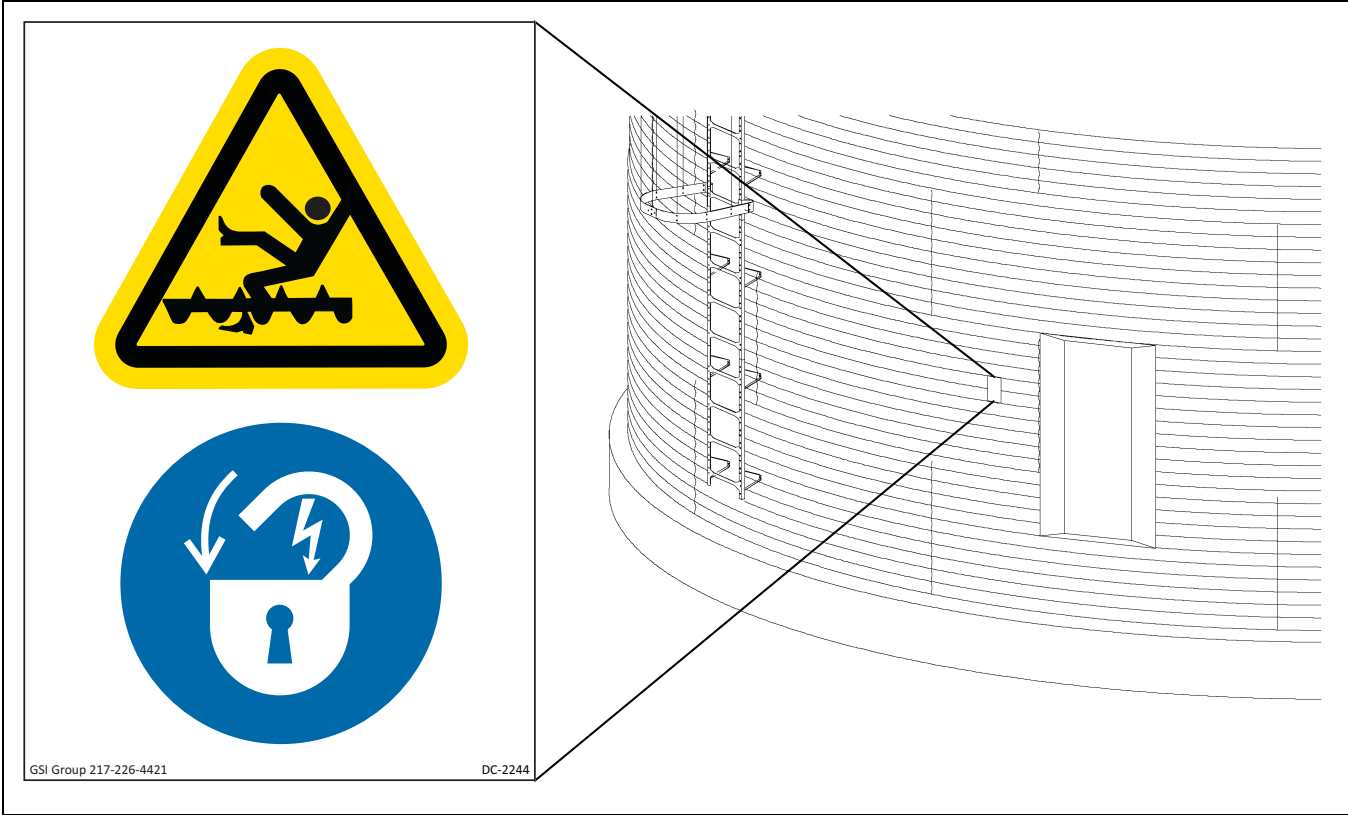

Figure 3C

4. Installation

Power Sweep in Bins with Concrete Floors

NOTE: We not recommend setting the direct gear drive bin sweep auger unit in concrete. If installing a unit flush with a concrete floor, we recommend that the unit be installed in a preformed trench. Use [Figure 4A](#) below.

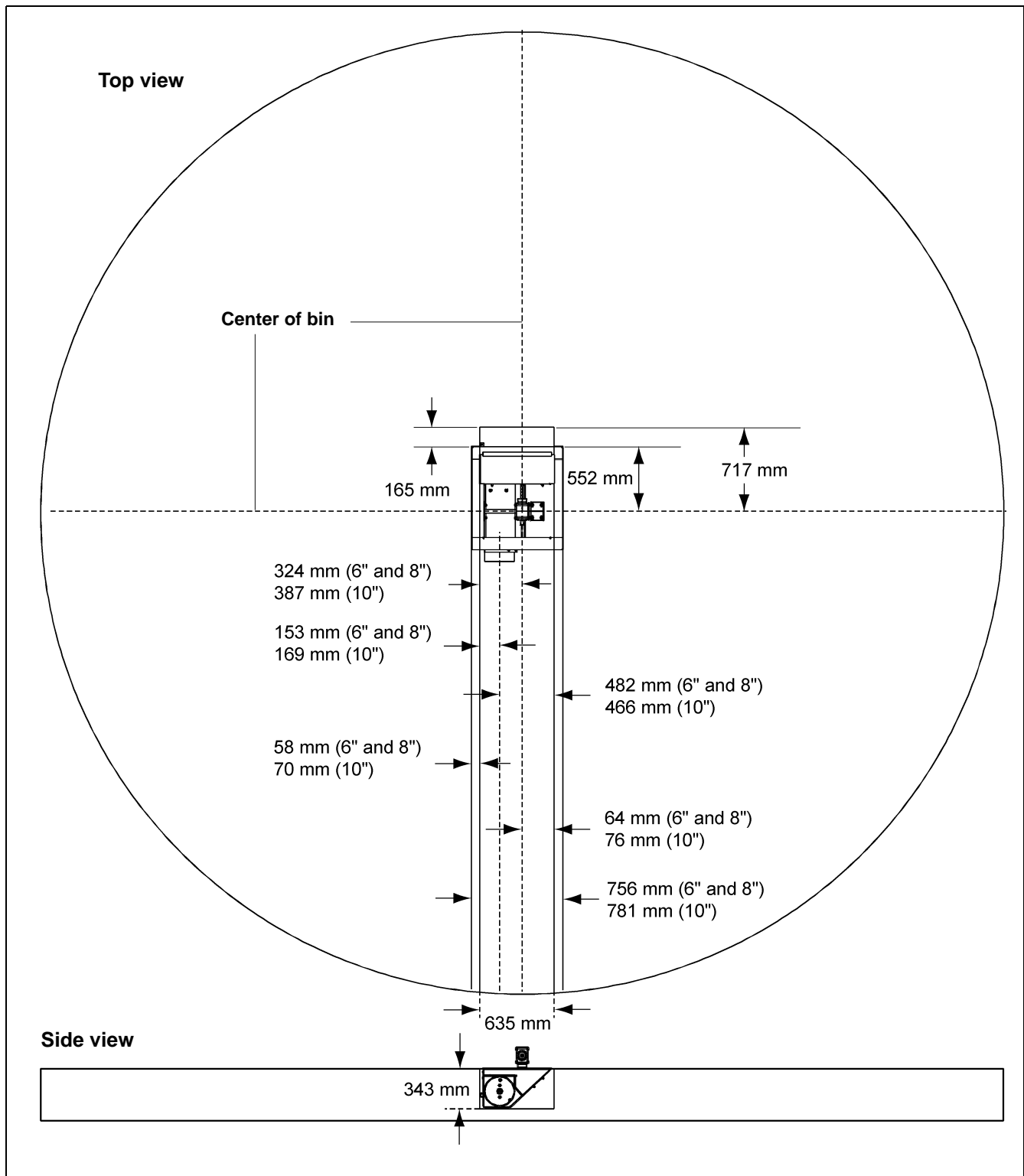

Figure 4A Concrete Trench Layout for 6", 8" and 10" Power Sweeps

Power Sweeps in Bins with Raised Metal Floors

For bins with raised metal floors, cut openings for the center well and intermediate wells. Floor must be high enough to provide space for the wells. Ideally, complete bin floor assembly whilst installing the power sweep.

1. Locate the center of the bin and make a cut-out for the center well. (See [Figure 4B](#) or [Figure 4C](#).)
2. Locate the vertical shaft between the gearboxes in the center of the bin and place suitable supports under the center well to hold it in position.

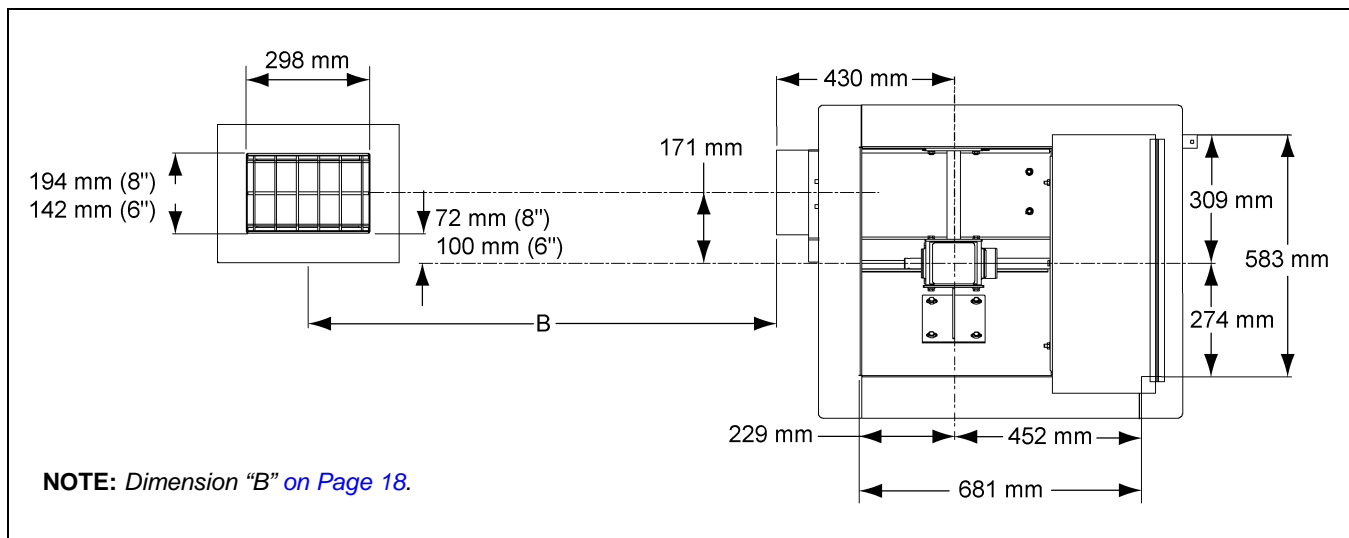

Figure 4B 6" and 8" Floor Well Cut-Outs

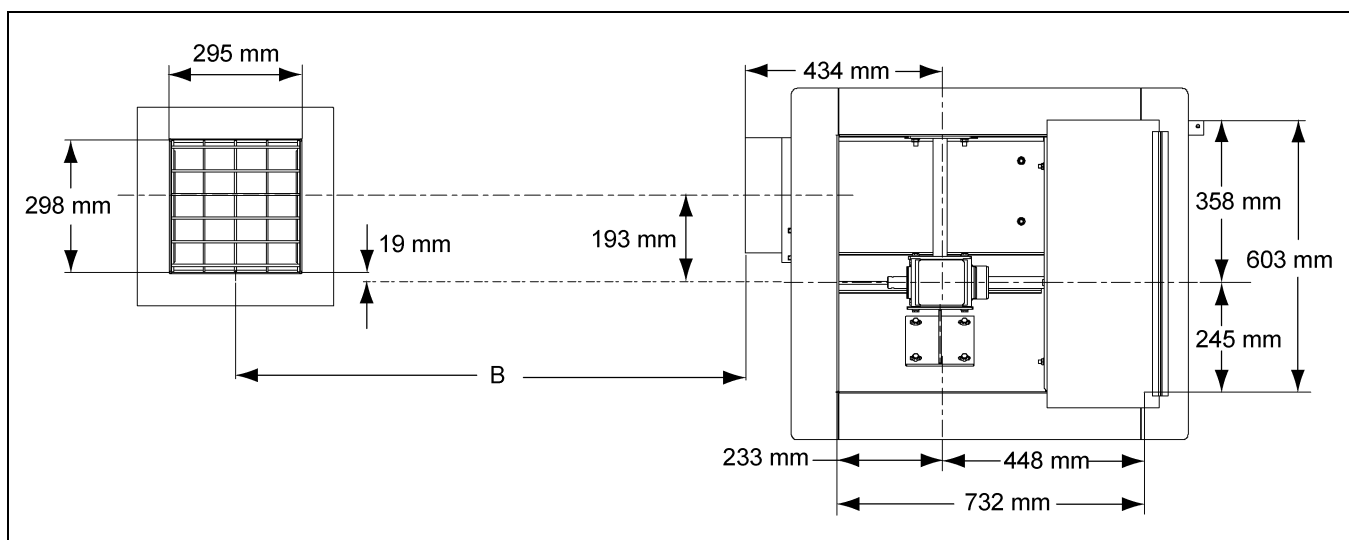

Figure 4C 10" Floor Well Cut-Outs

4. Installation

Intermediate Well Installation

1. Cut openings in the bin floor for the intermediate wells. *(See Figure 4B and Figure 4C on Page 17.)*
2. The number of wells depends on bin size.
3. The distances between intermediate wells and the center well should be equal. *See Figure 4D and Chart below.*

Bin Size	# of Intermediate Wells	A	B	C	D
15'	1	2273	1000	-	2870
18'	1	2729	933	-	3480
21'	2	3183	826	1264	3785
24'	2	3639	978	1416	4242
27'	2	4094	1130	1568	4699
30'	2	4547	1283	1721	5156
33'	3	5002	1005	1443	5766
36'	3	5458	1081	1519	5817
39'	3	5912	1195	1634	6528
42'	4	6367	991	1429	7137
48'	4	7277	1173	1612	8052

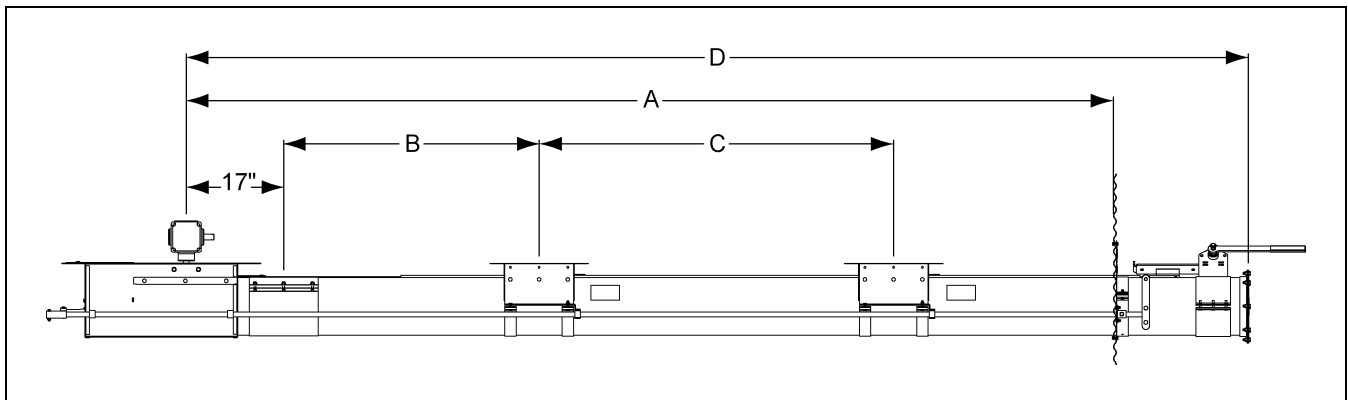

Figure 4D Wells Spacing

Unload Tube Installation

1. Cut an opening in the bin wall for the unloading tube to pass through. See chart [on Page 18](#) for hole information. (See [Figure 4E.](#))

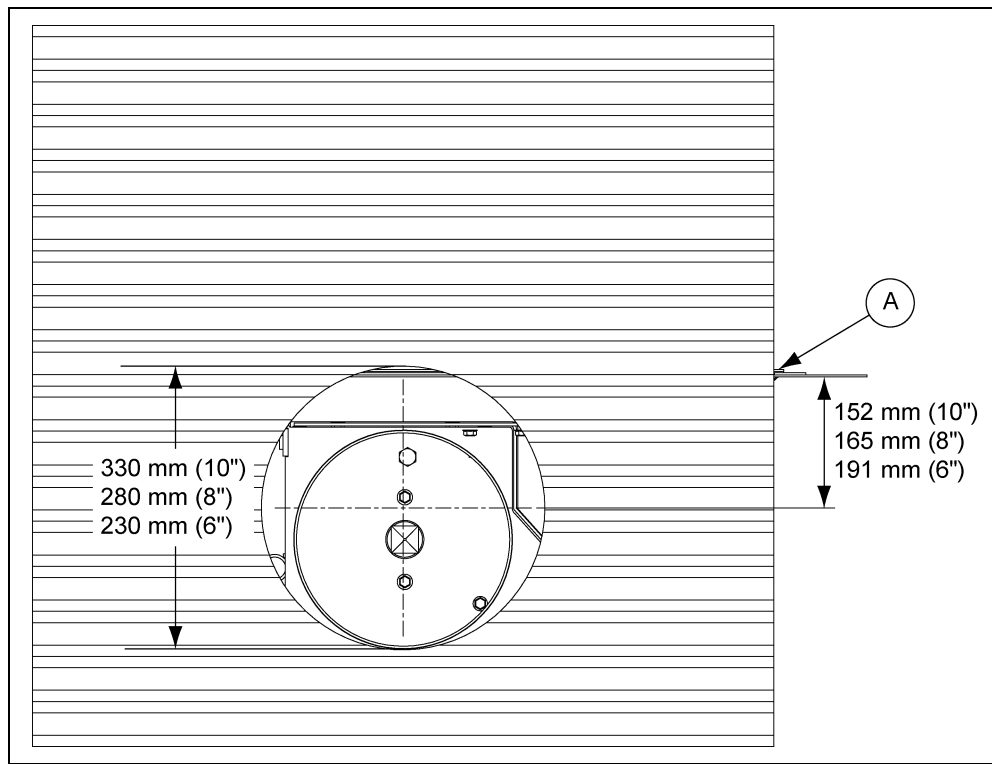

Figure 4E Wall Cut-Out

Ref #	Description
A	Bin Floor Level

2. From inside the bin, insert the angle ring end of the unload tube through the hole in the bin sidewall.

NOTE: Before installing tube, remove flight from inside of tube.

3. Place the connecting band onto the end of the unload tube closest to the center well. (See [Figure 4F.](#))

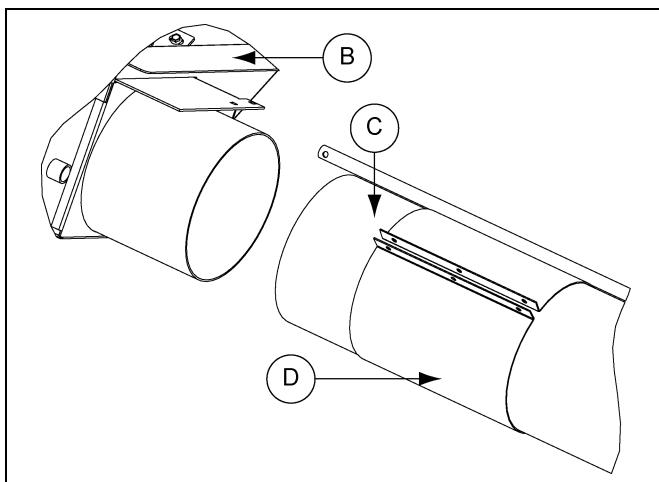

Figure 4F

Ref #	Description
B	Center Well
C	Unload Tube
D	Connecting Band

4. Installation

Unload Tube Installation (Continued)

4. Position the unload tube flush against the center well tube. (See Figure 4G.)

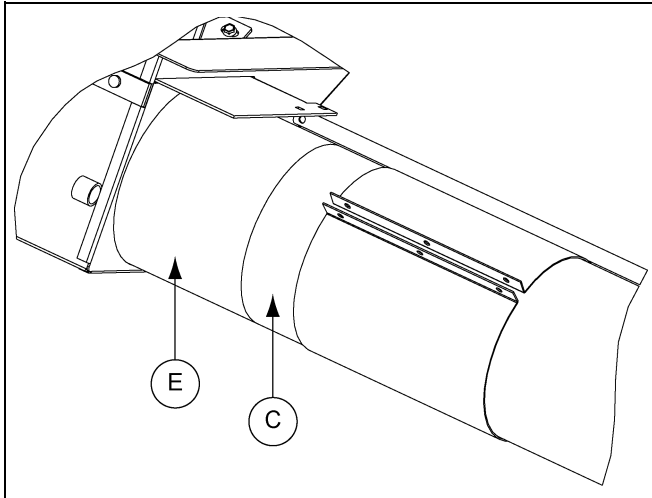

Figure 4G

Ref #	Description
C	Unload Tube
E	Center Well Tube

5. Slide the connecting band until it is equally positioned over both the unload tube and the center well tube. Position the connecting band so that it will not interfere with the control rods. (See Figure 4H.)

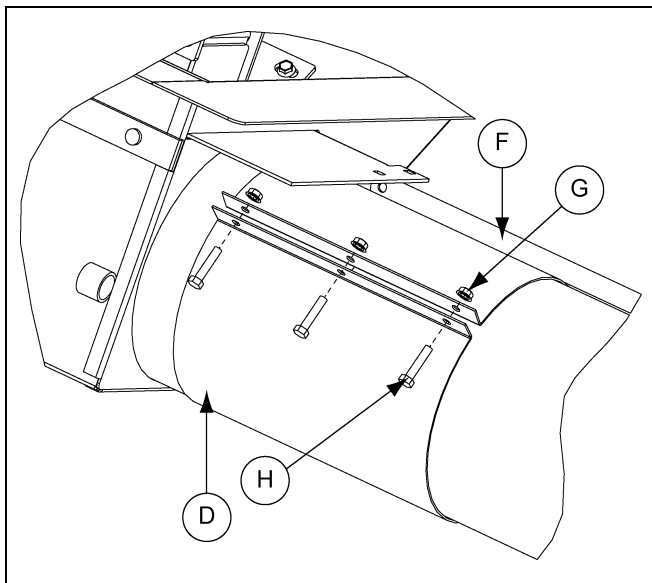

Figure 4H

Ref #	Description
D	Connecting Band
F	Control Rod
G	Serrated Flange Nut
H	5/16" x 1-1/2" Bolt

6. Secure the connecting band with three (3) 5/16" x 1-1/2" bolts and serrated flange nuts, making sure the intermediate wells are aligned to the center wells.

Install Bin Flange

1. Attach the upper and lower bin flanges loosely to the auger tube using two (2) 5/16" x 1-1/2" bolts and serrated flange nuts. (See Figure 4I.)

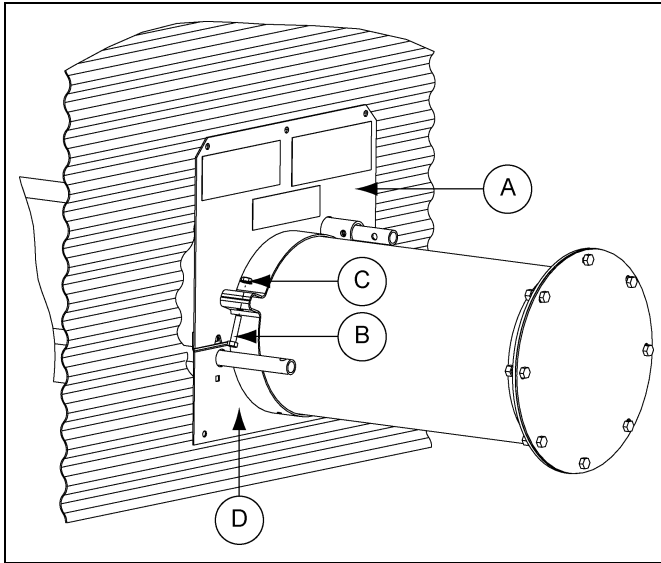

Ref #	Description
A	Upper Bin Flange
B	5/16" x 1-1/2" Bolt
C	Serrated Flange Nut
D	Lower Bin Flange

Figure 4I

2. Next, install the clutch lock collar to the lower bin flange using two (2) 5/16" x 3/4" carriage bolts and serrated flange nuts. Install the bolt heads on the backside of the lower bin flange so they will be next to the bin wall when the flanges are attached to the bin. (See Figure 4J.)

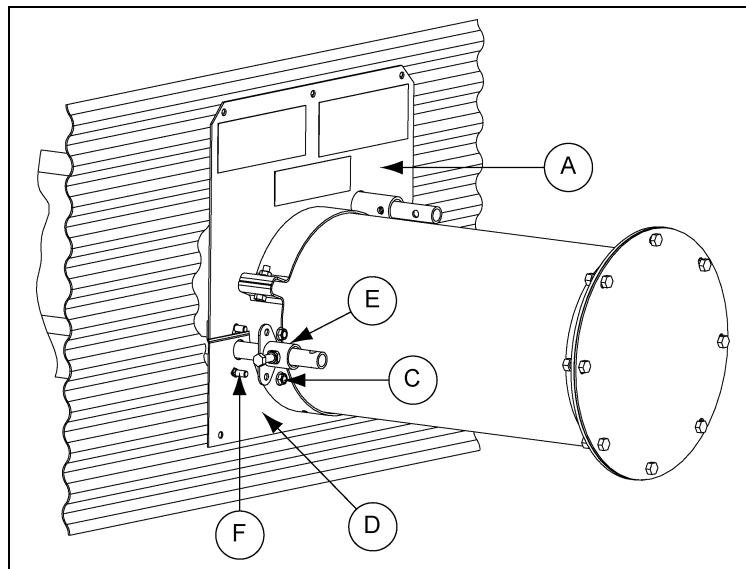

Figure 4J

Ref #	Description
A	Upper Bin Flange
C	Serrated Flange Nut
D	Lower Bin Flange

Ref #	Description
E	Clutch Lock Collar
F	5/16" x 3/4" Carriage Bolt

4. Installation

Install Bin Flange (Continued)

3. With the flange not yet attached to the bin wall, make sure that the bin wall opening is large enough for the clutch and well control rods to pass through the bin wall.
4. Slide the bin flanges flush up to the bin wall and tighten the bolts connecting the two (2) flanges.
5. Drill into the bin wall through the holes located on the four (4) corners of bin flanges. Fasten the bin flanges to the bin wall using four (4) 5/16" x 3/4" bin wall bolts and serrated flange nuts.
(See Figure 4K.)

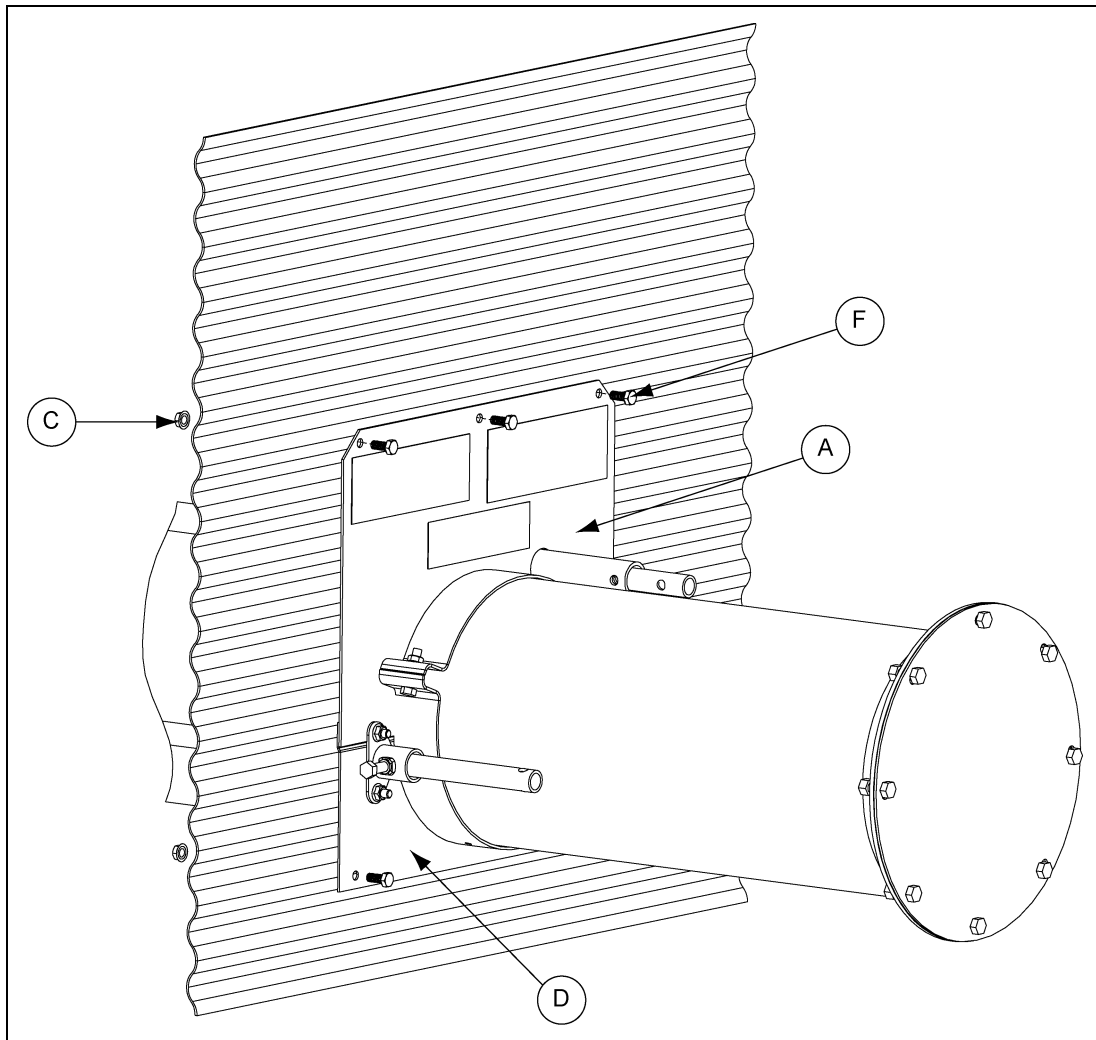

Figure 4K

Ref #	Description
A	Upper Bin Flange
C	Serrated Flange Nut

Ref #	Description
D	Lower Bin Flange
F	5/16" x 3/4" Carriage Bolt

6. Drill the remaining holes into the bin wall and attach the remaining 5/16" x 3/4" bin wall bolts and serrated flange nuts.

Center Well Slide Gate Assembly

1. Close the center slide gate completely.
2. Align control rod between holes in gate.
3. Attach control gate clamp to control rod by sliding 5/16" x 1-3/4" long roll pin through clamp and control pipe.
4. Fasten clamp to bottom side of control gate by using two (2) 5/16" x 3/4" long carriage bolts, flat washers and serrated flange nuts. (See Figure 4L.)

NOTE: 6" and 8" rods attach on the TOP side of the center well gate.

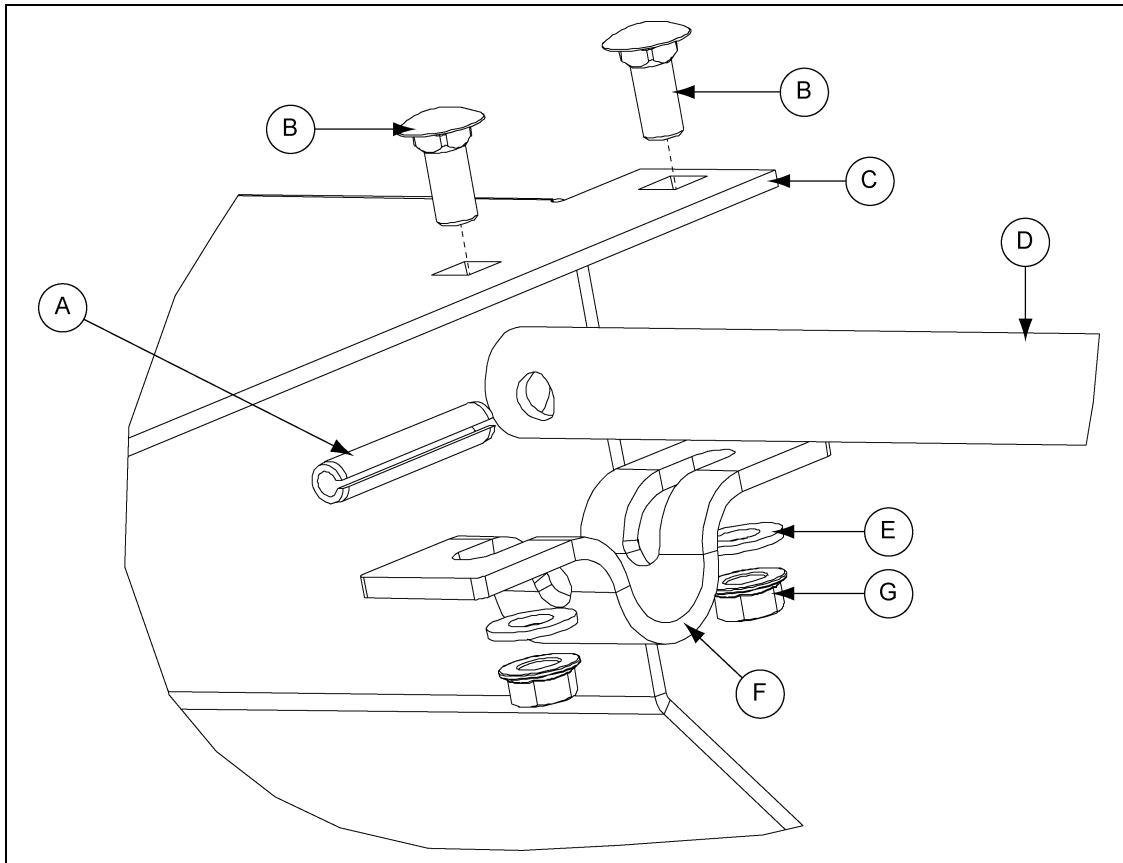

Figure 4L

Ref #	Description
A	5/16" x 1-3/4" Roll Pin
B	5/16" x 3/4" Carriage Bolts
C	Center Well Control Gate
D	Center Well Control Rod
E	Flat Washer
F	1/2" Control Gate Clamp
G	5/16" Serrated Flange Nut

4. Installation

Control Lever Installation (6" Systems)

1. Close all slide control gates and keep them closed.
2. Attach the control lever by sliding the safety snap-on pin through the lever and both control rods. Close the center well and intermediate well gates using the control lever and the various slots.
3. Place the safety snap-on pin through the center well control rod and the control lever as shown in [Figure 4M](#).

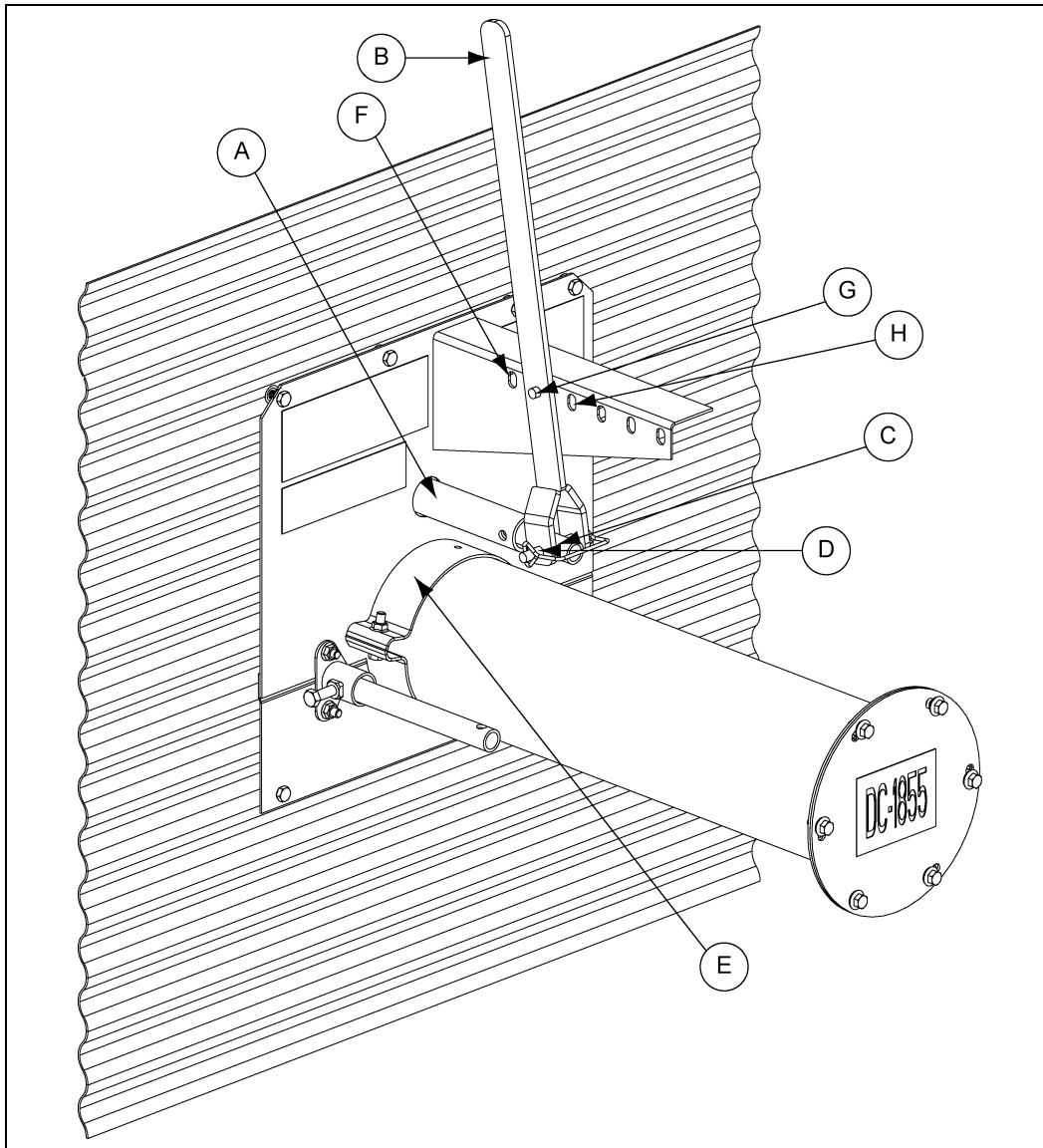

Figure 4M 6" Systems

Ref #	Description
A	Intermediate Well Control Rod
B	Control Lever
C	Center Well Control Rod
D	Safety Snap-On Pin

Ref #	Description
E	Bin Flange
F	Hole #1 (Gates Closed)
G	Hole #2 (Gates 1/2 Open)
H	Hole #3 (Gates Fully Open)

Rack and Pinion Installation (8" and 10" Systems)

1. Make sure all gates are fully closed.
2. Slip rack and pinion tube over center gate control rod and align holes, making sure rack and pinion is fully extended toward bin wall. (See Figure 4N.)
3. With rack and pinion resting on unload tube and tube holes aligned, insert one 5/16" x 1-3/4" bolt through the rack and pinion tube and center gate control rod. Fasten together with a nut. (See Figure 4N.)

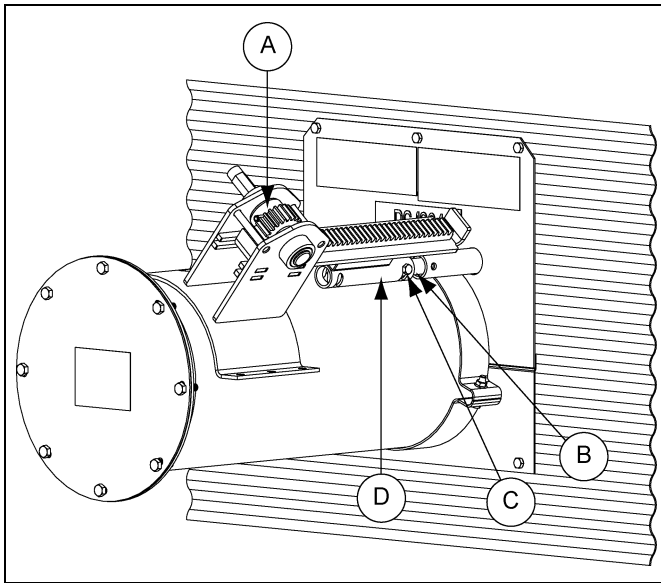

Figure 4N 8" and 10" Systems

Ref #	Description
A	Rack and Pinion
B	Center Well Control Rod
C	5/16" x 1-3/4" Bolt
D	Rack and Pinion Tube

4. Slide wrench over shaft on rack and pinion, making sure the collar faces the gears. Fasten down with 3/8" flat washer and 3/8" x 3/4" hex bolt. (See Figure 4O.)

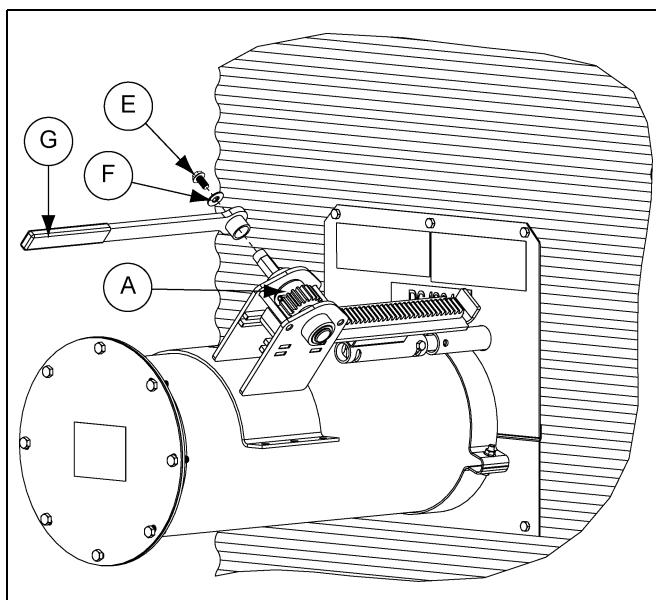

Figure 4O 8" and 10" Systems

Ref #	Description
A	Rack and Pinion
E	3/8" x 3/4" Hex Bolt
F	Flat Washer
G	Wrench

4. Installation

Rack and Pinion Installation (8" and 10" Systems) (Continued)

5. With rack and pinion fully extended, attach lower half band and secure to unload tube with six (6) 5/16" x 1-1/2" bolts, washers and serrated flange nuts. (See Figure 4P.)
6. To open all gates, with center gate closed, place second 5/16" x 1-3/4" bolt through center gate control rod and intermediate gate control rod and secure with nut.

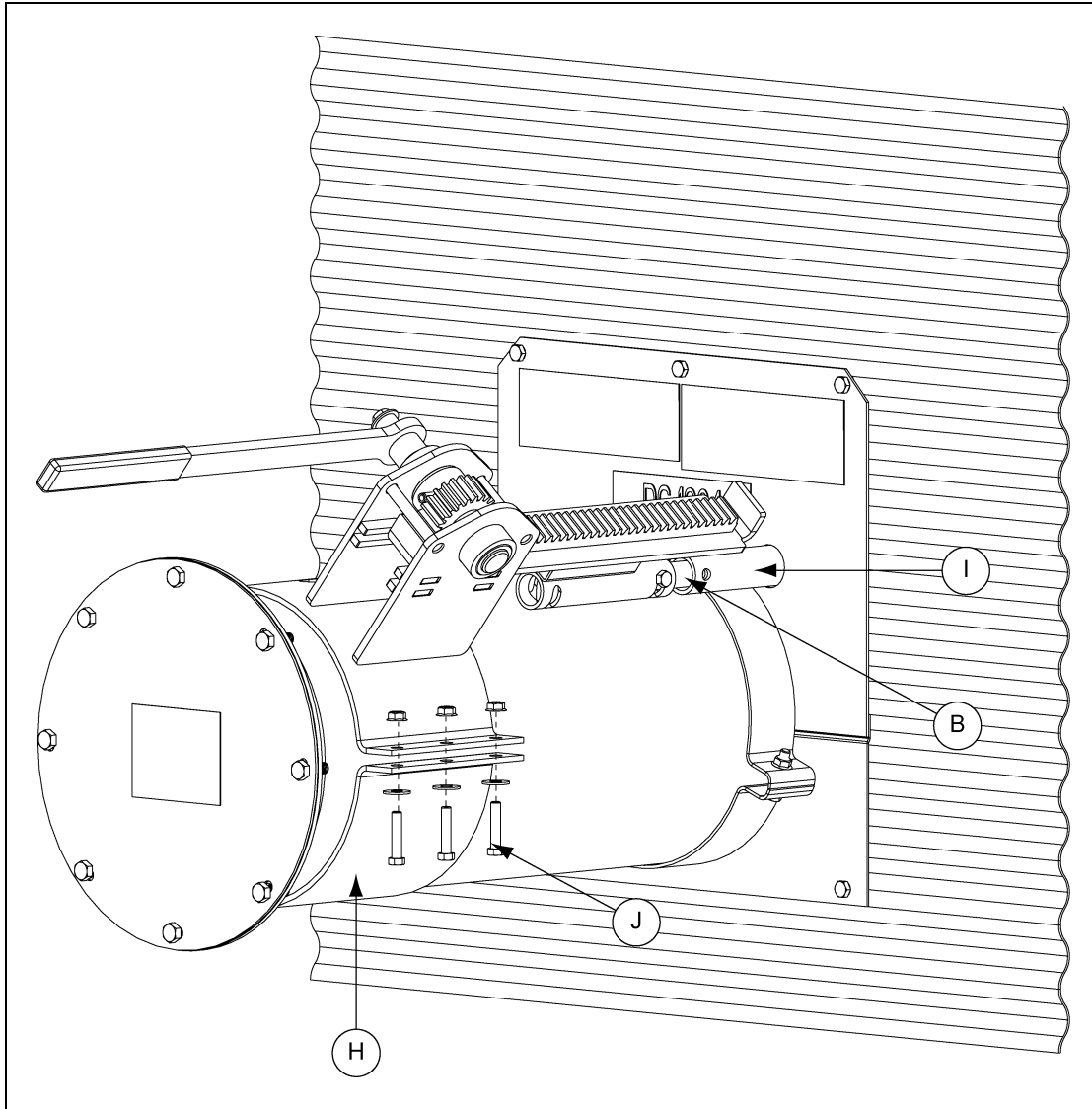

Figure 4P 8" and 10" Systems

Ref #	Description
B	Center Well Control Rod
H	Lower Half Band
I	Intermediate Well Control Rod
J	5/16" x 1-1/2" Bolt

Clutch Control Installation

- Slide the clutch control pipe through the bin flange and the support brackets on the intermediate and center wells. Slide the clutch control pipe into clutch collar on the center well. (See [Figure 4Q](#) and [Figure 4R](#).)

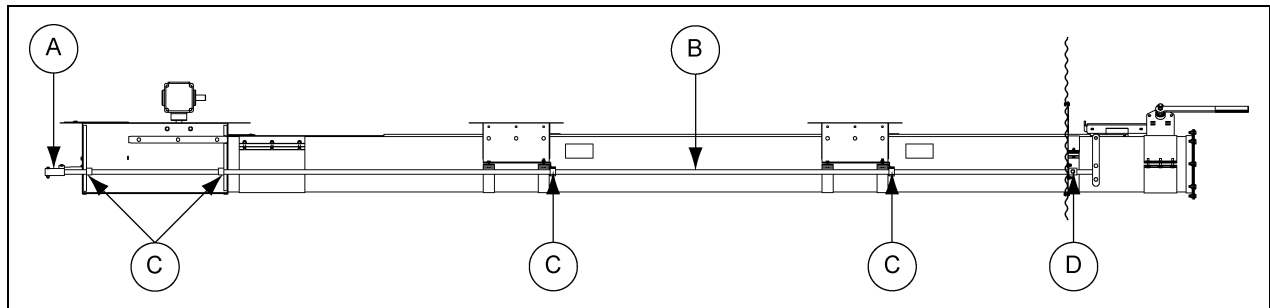

Figure 4Q

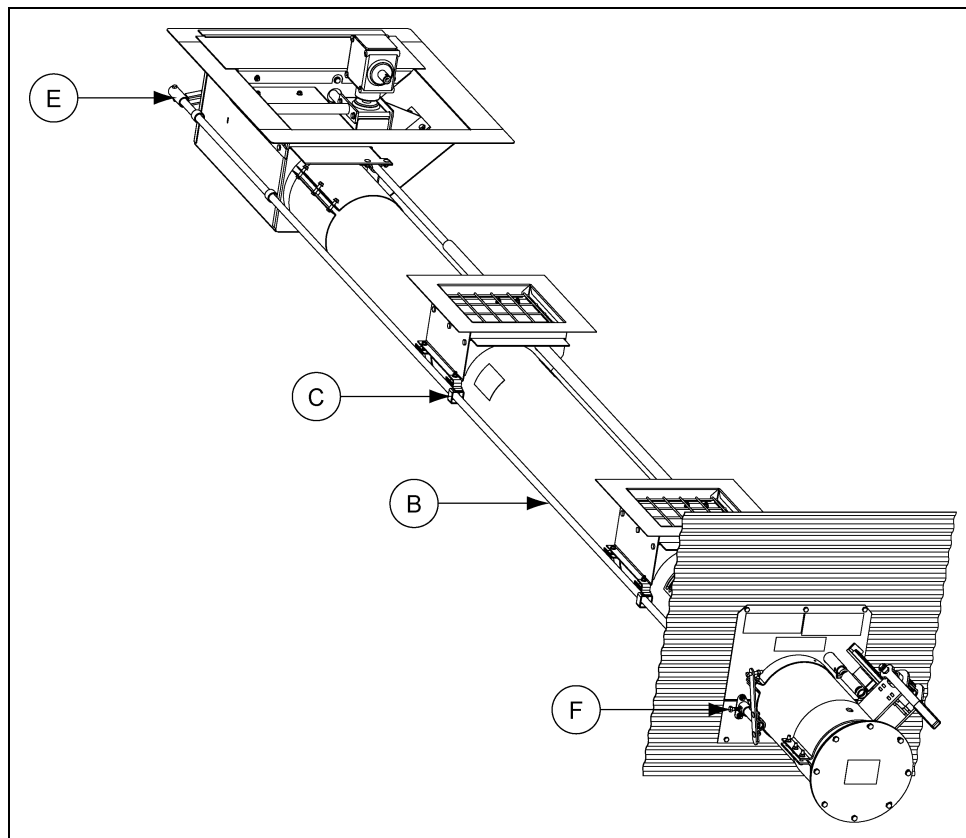

Figure 4R

Ref #	Description
A	Clutch Collar
B	Clutch Control Pipe
C	Support Brackets

Ref #	Description
D	Lock Collar
E	Clutch
F	Lock Collar Bolt

4. Installation

Clutch Control Installation (Continued)

2. Bolt the clutch control pipe to the collar on the center well using a 5/16" x 1-3/4" long bolt and lock nut. (See Figure 4S.)

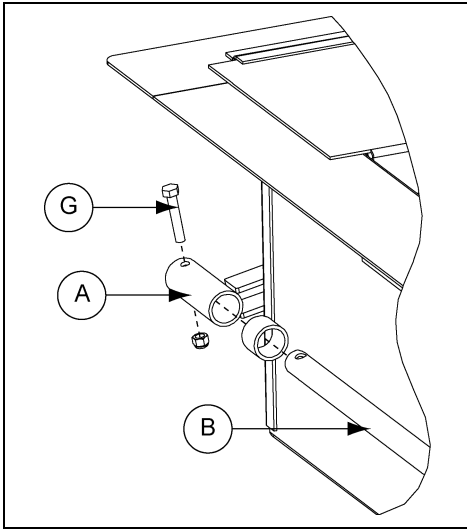

Figure 4S

Ref #	Description
A	Clutch Collar
B	Clutch Control Pipe
G	5/16" x 1-3/4" Long Bolt

3. Attach the control rod clamp to the clutch rod by sliding 5/16" x 1-3/4" long roll pin through the clamp and control rod.
4. Fasten the clutch handle to the clamp using two (2) 5/16" x 3/4" carriage bolts, flat washers and serrated flange nuts. The short end of the clutch handle should be closest to the bin pad, so as not to interfere with it. Install the nuts so that they secure the roll pin in place. (See Figure 4T.)

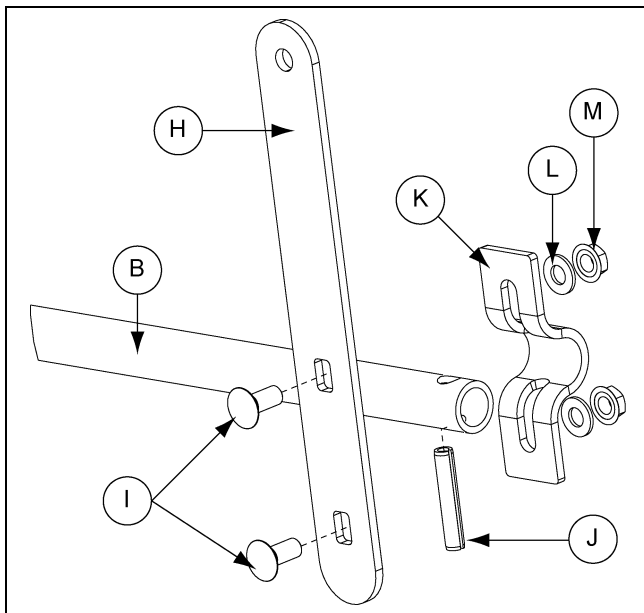

Figure 4T

Ref #	Description
B	Clutch Control Pipe
H	Clutch Handle
I	5/16" x 3/4" Carriage Bolts
J	5/16" x 1-3/4" Roll Pin
K	1/2" Control Rod Clamp
L	Flat Washer
M	5/16" Serrated Flange Nut

NOTE: *Clutch control pipe is shipped INSIDE unload flight.*

5. Check operation of clutch by pulling the handle to engage the clutch and then pushing the handle to disengage it. The control pipe should slide freely. Lock the control pipe into the disengaged position by tightening the bolt on the lock collar that is attached to the bin flange. (See Page 27.)

Installing the Unload Tube Flight

1. Begin by removing the tube end cap if you have not already done so.
2. Insert the flight into the tube with the square bushing end facing the center well and the round bushing end facing the discharge end of the tube. (See Figure 4U.)

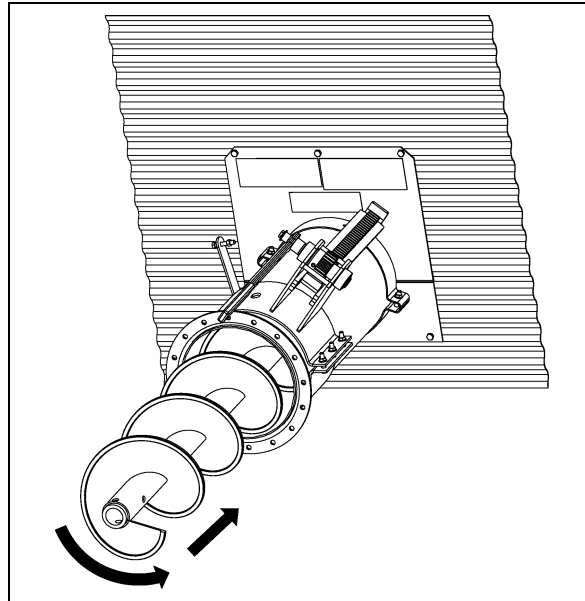

Figure 4U

3. When the flight is approaching the center well shaft, it will be necessary to rotate the flight counterclockwise in order to get it to seat properly on the squared clutch shaft. When the flight is properly seated, the flight should be entirely inside the unload tube. It may be necessary to pull the flight out, a small amount and attempt this step multiple times in order to seat the flight properly. (See Figure 4V.)

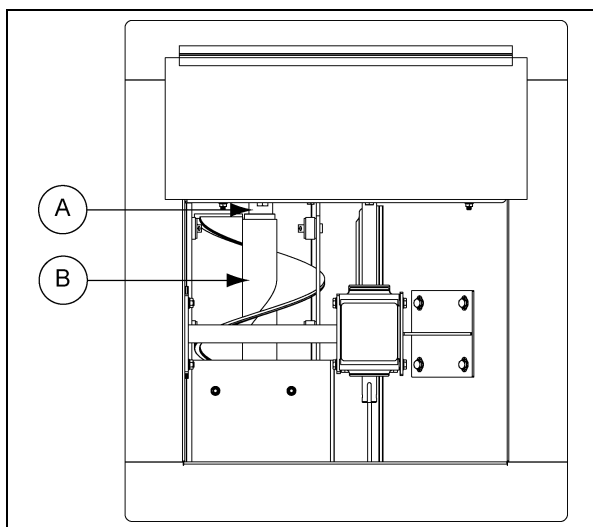

Figure 4V

Ref #	Description
A	Clutch Shaft
B	Flight

4. On the initial stage, install with an empty bin, the installer might want to open the center well and enter the bin to check and see that the flight is seated. Once they have seen that it has seated, they will know the proper position of the flight on the discharge end when it has seated properly. (See Figure 4V.)

4. Installation

Install the Sweep Flighting

1. Assemble the U-joint.
 - a. Insert the stub into the U-joint.
 - b. Secure the U-joint using a 5/16" x 2" roll pin. Drive the pin in with a hammer. *(See Figure 4W.)*

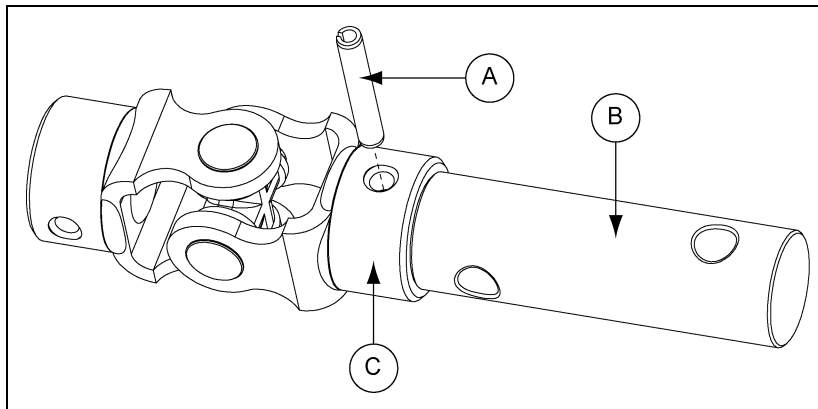

Figure 4W

Ref #	Description
A	5/16" x 2" Roll Pin
B	Stub
C	U-Joint

2. Attach the U-joint.
 - a. Slide the U-joint onto the top gearbox output shaft.
 - b. Secure the U-joint using a 5/16" x 2" roll pin. *(See Figure 4X.)*

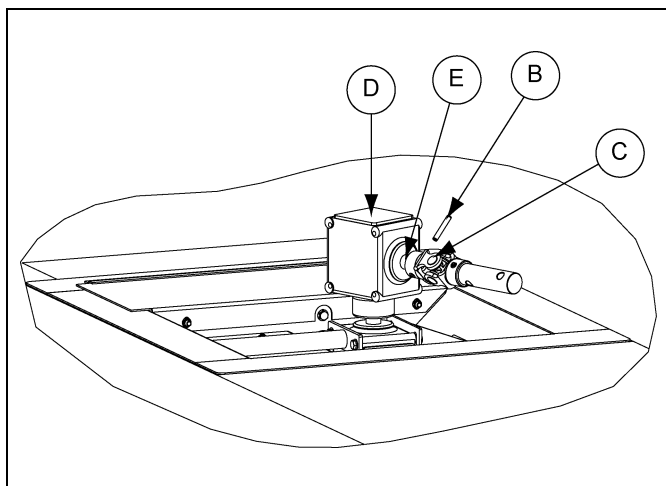

Figure 4X

Ref #	Description
B	5/16" x 2" Roll Pin
C	U-Joint
D	Top Gearbox
E	Output Shaft

Install the Sweep Flighting (Continued)

3. Attach the pivot bracket to the left side of the gearbox using four (4) 3/8" x 3/4" flange bolts. (See Figure 4Y.)

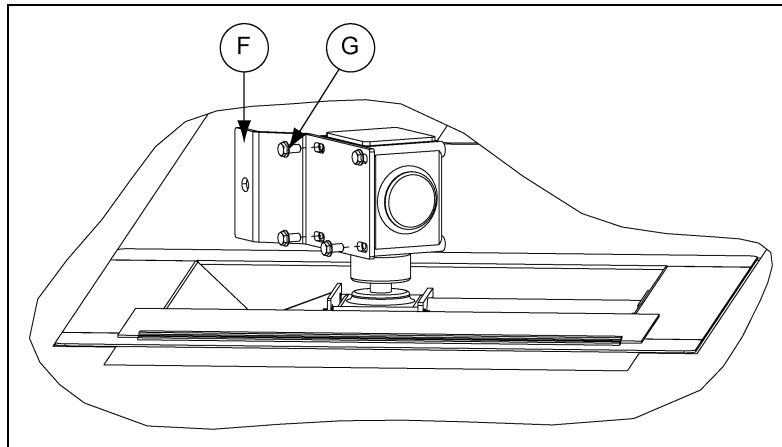

Figure 4Y

Ref #	Description
F	Pivot Bracket
G	3/8" x 3/4" Flange Bolt

4. Attach a flighting section to the U-joint stub located on the gearbox. Making sure that the Dura-Edge[®] side of the flight faces the center of the bin. Secure it with bolts and stover nuts. (See Note for Bolt Size and Figure 4Z.)

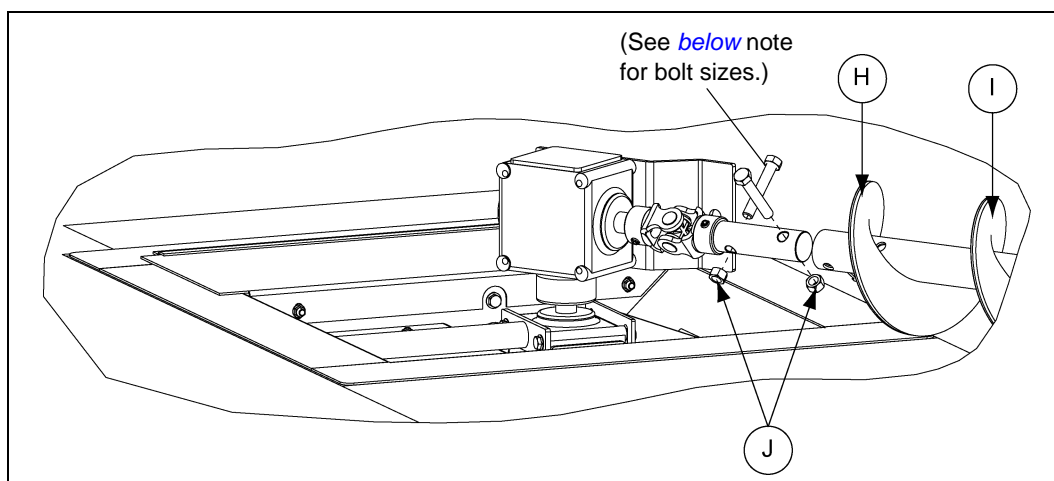

Figure 4Z

NOTE: 6" Two (2) 7/16" x 3" bolts.
 8" Two (2) 1/2" x 3" bolts.
 10" Two (2) 1/2" x 3" bolts.

Ref #	Description
H	Dura-edge [®]
I	Flight
J	Stover Nuts

4. Installation

Install the Sweep Flighting (Continued)

Use the [Chart below](#) to determine the number of flighting and shield sections needed for the length of sweep to be used.

Bin Size	Number of Flighting and Shields Required	Lengths
15'	1	5' 6"
18'	1	7' 0"
21'	1	8' 6"
24'	1	4' 4"
24'	1	5' 6"
27'	1	5' 6"
27'	1	5' 10"
30'	1	5' 6"
30'	1	7' 4"
33'	1	5' 10"
33'	1	8' 6"
36'	1	7' 4"
36'	1	8' 6"
39'	1	8' 6"
39'	1	8' 10"
42'	1	4' 4"
42'	1	7' 0"
42'	1	7' 4"
48'	1	7' 0"
48'	2	7' 4"

5. Insert the connecting stub into the flighting. Secure it with bolts and stover nuts. ([See Note for Bolt Size on Page 31 and Figure 4AA below.](#))

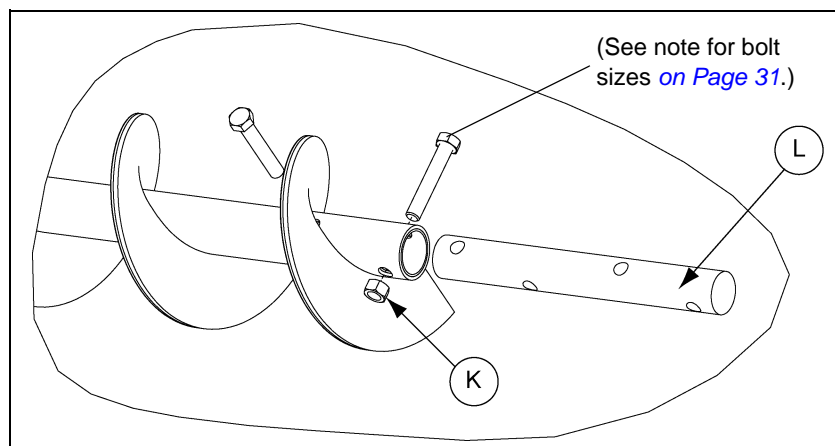

Figure 4AA

Ref #	Description
K	Stover Nut
L	Connecting Stub

Install the Sweep Flighting (Continued)

6. Place the hanger bearing bracket onto the connecting stub. *(See Figure 4AB.)*

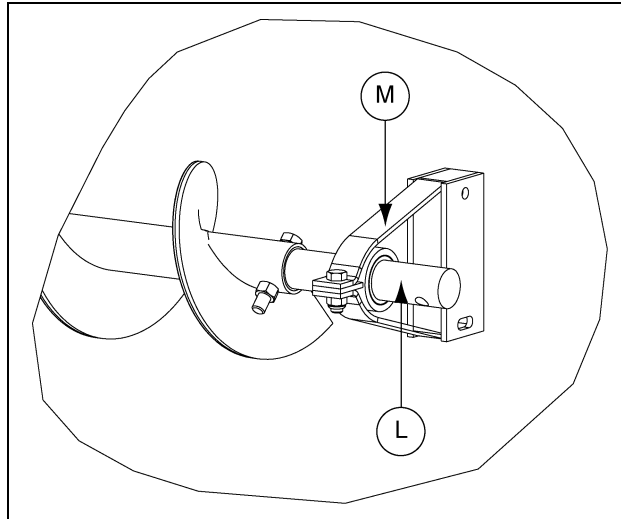

Figure 4AB

Ref #	Description
L	Connecting Stub
M	Hanger Bearing Bracket

7. Install the next section of flighting onto the connecting stub. Secure the flighting with bolts and stover nuts. *(See Note for Bolt Size on Page 31 and Figure 4AC below.)*
8. Keep repeating *Step 5 on Page 32-Step 7 above* for additional sections of flighting.

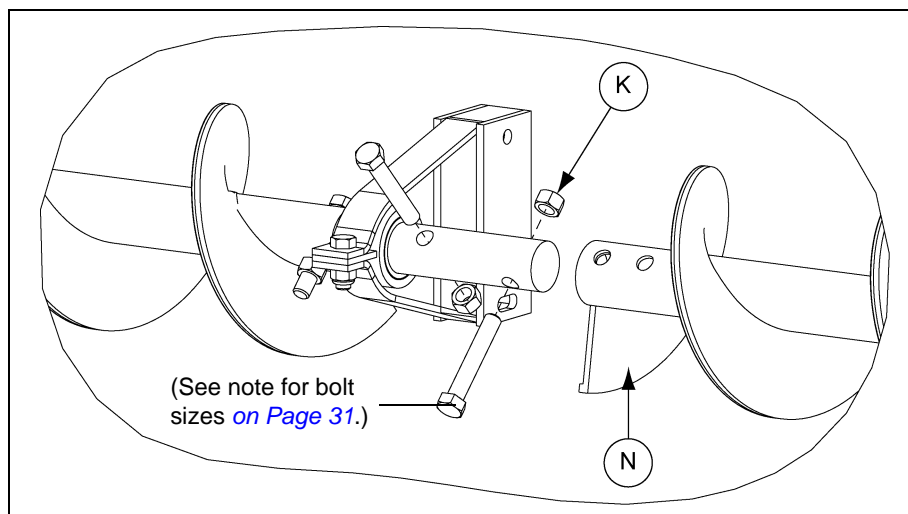

Figure 4AC

Ref #	Description
K	Stover Nut
N	Sweep Flighting

4. Installation

Install the Flighting Shield

1. Install the first shield to the shield mounting bracket. Secure using two (2) 3/8" x 1-1/4" bolts, flat washers and lock nuts. (See Figure 4AD.)
2. Fasten the shield bracket to the pivot bracket on the gearbox using one 1/2" x 1/2" shoulder bolt and lock nut. (See Figure 4AD.)

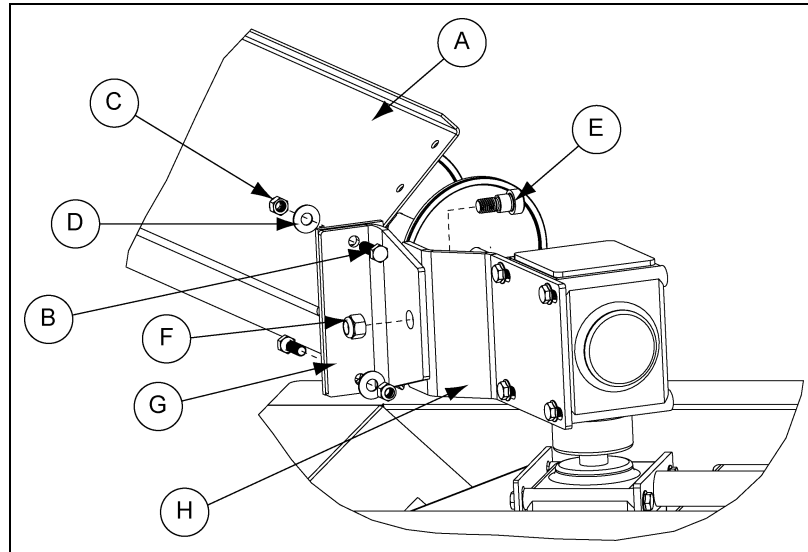

Figure 4AD

Ref #	Description
A	First Back Shield
B	3/8" x 1-1/4" Bolt
C	3/8" Nylon Lock Nut
D	3/8" Flat Washer

Ref #	Description
E	1/2" x 1/2" Shoulder Bolt
F	1/2" Nylon Lock Nut
G	Shield Mounting Bracket
H	Pivot Bracket

3. Install the first and second flighting shield (when applicable) to the hanger bracket using two (2) 3/8" x 3" carriage bolts, flat washers and lock nuts. (See Figure 4AE.)

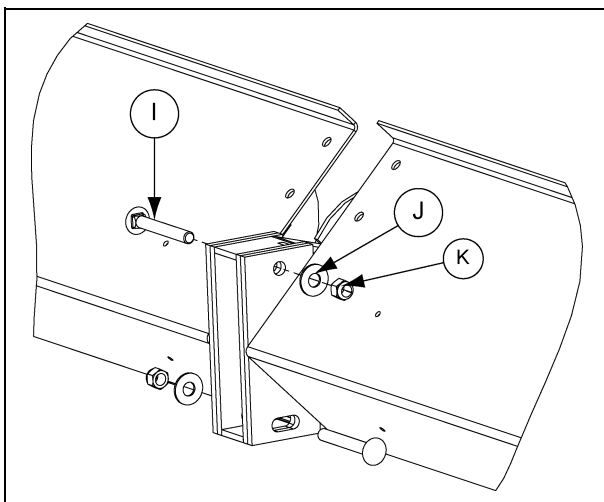

Figure 4AE

Ref #	Description
I	3/8" x 3" Carriage Bolt
J	3/8" Flat Washer
K	3/8" Lock Nut

Install the Flighting Shield (Continued)

4. Install shield splice brackets to back side of flighting shields using four (4) 5/16" x 3/4" bolts, flat washers and serrated flange nuts. (See Figure 4AF.)

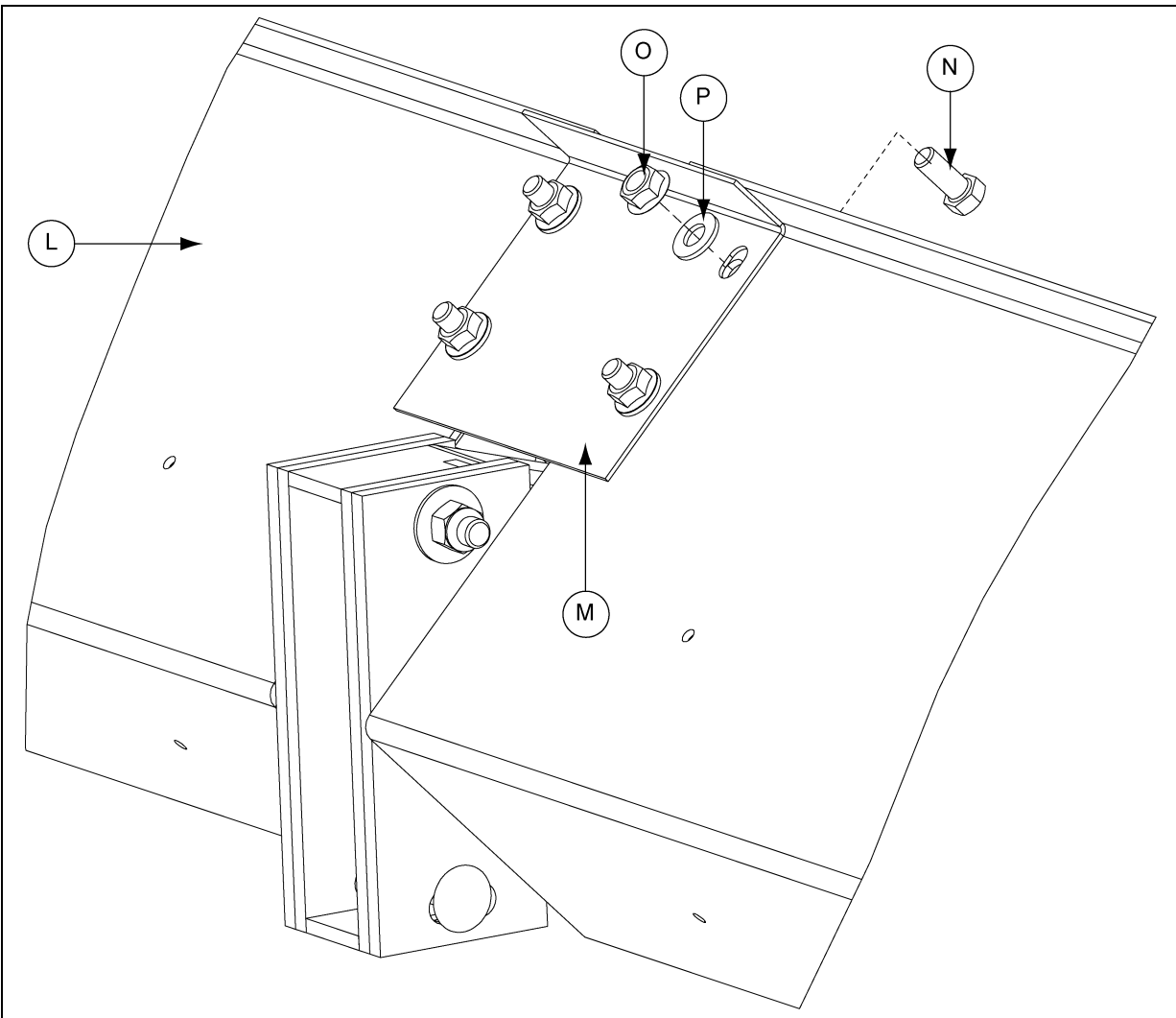

Figure 4AF

Ref #	Description
L	Shield
M	Shield Splice Bracket
N	5/16" x 3/4" Bolt
O	5/16" Serrated Flange Nut
P	5/16" Flat Washer

5. Keep repeating [Step 3 on Page 34](#) and [Step 4 above](#) for additional sections of flighting shields.

4. Installation

Sweep Wheel Installation

1. Insert the input shaft of the reduction drive into the open end of the flight. Attach the drive to the flight with one 7/16" x 3" grade 8 bolt and stover nut for 6" or one 1/2" x 3" grade 8 bolt and stover nut for 8" and 10". (See Figure 4AG.)
2. Mount the reducer to the back shield with two (2) 3/8" x 1-1/4" serrated flange bolts, one flat washer and nylock nut.
3. Attach the wheel hub welded assembly to the reduction drive with one 3/8" x 2-1/2" grade 8 bolt and stover nut.
4. Attach the rubber discs and outer wheel disc to the wheel hub welded assembly with four (4) 5/16" x 2" grade 2 bolts and nylock nuts. (See Figure 4AG.)

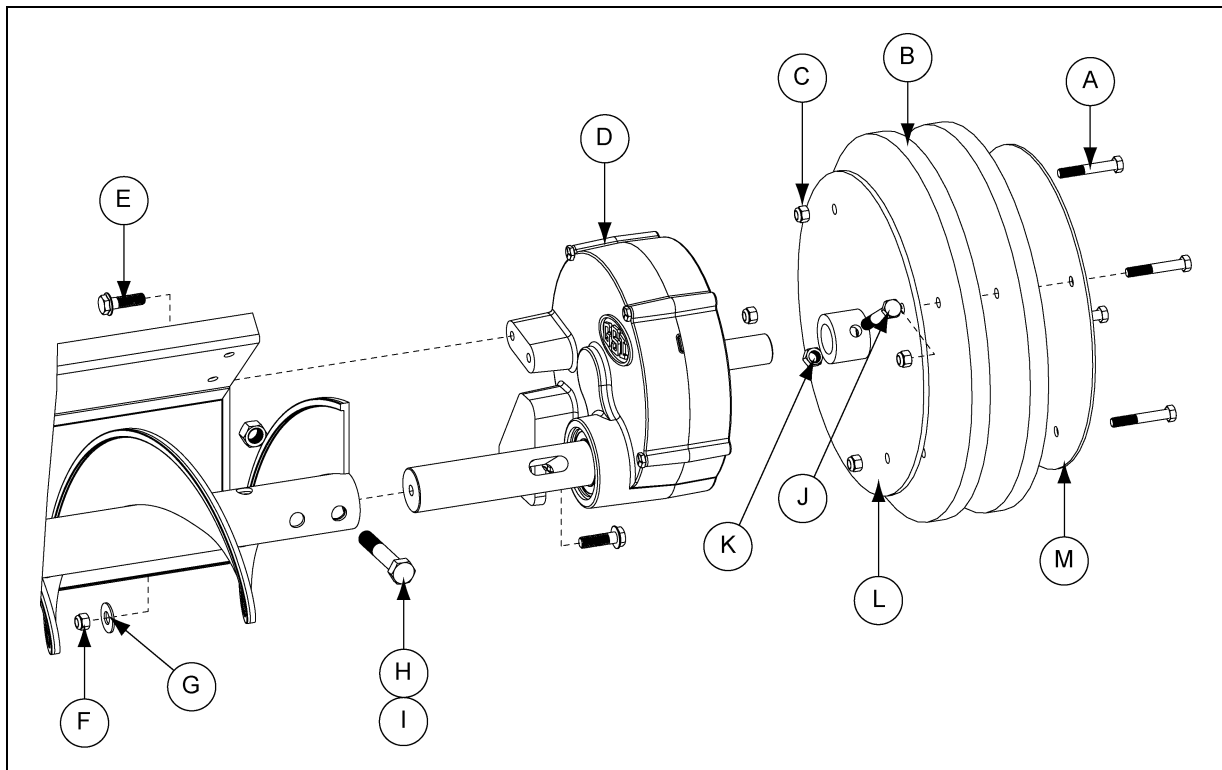

Figure 4AG

Ref #	Description
A	5/16" x 2" Bolt
B	Rubber Disc
C	5/16" Nylock Nut
D	Wheel Reducer Drive
E	3/8" x 1-1/4" Flange Bolt
F	3/8" Nylock Nut
G	3/8" Flat Washer

Ref #	Description
H	7/16" x 3" Grade 8 Bolt and Stover Nut for 6"
I	1/2" x 3" Grade 8 Bolt and Stover Nut for 8" and 10"
J	3/8" x 2-1/2" Grade 8 Bolt
K	3/8" Stover Nut
L	Hub Welded Assembly
M	Outer Wheel Disc

Motor Requirements

Motor size depends on the style of bin unload head selected and on the grain type being conveyed. Minimum motor sizes are given below. Please also refer to the unload head manual for further details.

Bin Diameter	Horizontal Head			25° Head			Vertical Head		
	6"	8"	10"	6"	8"	10"	6"	8"	10"
15'	2.3	2.3	-	2.3	3.8	-	3.8	3.8	-
18'	2.3	2.3	-	2.3	3.8	-	3.8	3.8	-
21'	2.3	3.8	-	3.8	3.8	-	3.8	5.6	-
24'	2.3	3.8	5.6	3.8	3.8	7.5	3.8	5.6	7.5
27'	3.8	3.8	5.6	3.8	3.8	7.5	3.8	5.6	7.5
30'	3.8	3.8	5.6	3.8	5.6	7.5	5.6	5.6	11.3
33'	3.8	3.8	5.6	3.8	5.6	7.5	5.6	5.6	11.3
36'	3.8	5.6	7.5	3.8	5.6	7.5	5.6	5.6	11.3
39'	-	5.6	7.5	-	7.5	11.3	-	-	-
42'	-	5.6	7.5	-	7.5	11.3	-	-	-
48'	-	5.6	7.5	-	7.5	11.3	-	-	-

Minimum motor power requirements (kW).

Electrical Control System

Correct design of the control system is vitally important to ensure safe use of the power sweep and unloading auger. In particular:

1. No-one can enter the bin when the system is running.
2. The system is not started when some-one is in the bin.
3. For service and maintenance purposes, the equipment can be locked out with no risk if inadvertent re-start.

The following items are the minimum required when making electrical connections to the auger:

1. Main power supply with protective earth, over-current and short circuit protection.
2. Main electrical disconnect.



- a. Wired to disconnect all electrical power to the auger and other associated equipment.
- b. Lockable.

5. Electrical Installation

3. Service disconnect.



- a. Wired to break all electrical power to the auger motor.
- b. Lockable.

4. Emergency stop.



- a. Wired to stop the auger motor (and any other associated equipment) immediately when pressed.
- b. Must remain engaged until manually disengaged.

5. Start/Stop controls.



- a. Recessed start push button labelled 1.
- b. Non recessed stop push button labelled 0.
- c. Motor starter, short circuit protection and motor overload.
- d. Control must be designed to default to OFF after a power interruption. (Eg. Self maintained relay.)
- e. The auger **MUST NOT** be able to immediately re-start following re-establishment of power.

6. Door interlocks.



- a. Fitted on all bin access doors (including roof hatches).
- b. Door interlock to be wired to stop the auger (and any other equipment) immediately the door is opened.
- c. Auger **MUST NOT** be able to re-start immediately the door is re-closed.
- d. This does not override the need to LOCK OUT electrical power before entering the bin.



Figure 5A *Door Interlock Switch Locations*

Setting Clutch Control

1. Read the instructional decal located on the upper bin flange to learn how to control the direct gear drive power sweep well gates.
2. Push the center well and the intermediate well control rods towards the bin to close well gates.
3. With the power shut OFF and locked out enter the bin and position the sweep auger along side of the intermediate wells.
4. Open the center well cover plate and set it aside.
5. While observing the clutch components in the center well, pull the clutch control pipe from the outside of the bin, until the two (2) clutch jaws are fully engaged.
6. Make a distinguishing mark on the clutch control rod, outside the bin, to designate the fully engaged position.
7. Next, push the clutch control pipe toward the bin to disengage the two (2) clutch jaws.
8. Verify that the clutch is fully disengaged in the center well.
9. Make a distinguishing mark on the clutch control rod, outside the bin, to designate the fully disengaged position.
10. Tighten the clutch control pipe position lock out bolt.
11. Re-install the center well cover plate.

Power Recommendations

1. The horsepower recommendations are for augering reasonably dry grain. High moisture grain above (15%) will require greater power if maximum capacity is to be maintained. The maximum possible capacity will be less with high moisture grain than with dry grain. Use an electric motor of the correct size that operates at 1750 RPM. DO NOT use a motor size that is greater than what is shown for the largest bin size in the column.
2. Consideration should be given to the proper size auger for a batch drying or any intermittent type operations. When augers are stopped and restarted under full load, it may result in damage to the auger. Using a larger diameter auger and reducing its load level will be far better than subjecting a smaller diameter auger to big loads. If an auger is kept from absolute filling, it will make start-up easier and will convey more efficiently.

NOTE: *The auger capacity can fluctuate greatly under varying conditions. Moisture content, different commodities, amount of foreign matter and speeds all play a part in the performance of the auger. Twenty-five percent (25%) moisture may cut capacity by as much as forty percent (40%) under some conditions.*

Horsepower Chart

Bin Diameter	Horizontal Head			25° Head			Vertical Head		
	6"	8"	10"	6"	8"	10"	6"	8"	10"
15'	3	3	-	3	5	-	5	5	-
18'	3	3	-	3	5	-	5	5	-
21'	3	5	-	5	5	-	5	7-1/2	-
24'	3	5	7-1/2	5	5	10	5	7-1/2	10
27'	5	5	7-1/2	5	5	10	5	7-1/2	10
30'	5	5	7-1/2	5	7-1/2	10	7-1/2	7-1/2	15
33'	5	5	7-1/2	5	7-1/2	10	7-1/2	7-1/2	15
36'	5	7-1/2	10	5	7-1/2	10	7-1/2	7-1/2	15
39'	-	7-1/2	10	-	10	15	-	-	-
42'	-	7-1/2	10	-	10	15	-	-	-
48'	-	7-1/2	10	-	10	15	-	-	-

6. Operation

Perform Pre-Start Checks



Failure to perform any or all of these pre-start checks may cause damage to the equipment and/or cause *SERIOUS INJURY* or *DEATH* to those in the work area. Failure to perform any or all of these pre-start checks may also be a misuse of the equipment. Any misuse of the equipment may void the warranty.

1. Make sure ALL belts are tensioned properly.
2. Make sure ALL shields are in place and that the belt(s) and pulley(s) are able to move freely.



***ALWAYS* keep ALL guards and shields in place, until all the power is disconnected and locked out.**

3. Inspect the drive unit for any problems or potential problems.
4. Be aware of any emergency shut down procedures. Two (2) people must always be in a position where the operation of the equipment can be monitored.
5. Before starting the auger for the first time, make sure that all parts are assembled correctly according to the instructions in this manual.



Make certain *ONLY* trained operators are in the work area before operating or moving the machine. Two (2) people must always be in a position where the operation of the equipment can be monitored.

Operation



***DO NOT* start/stop the auger while it is under load, this may cause the auger to “jam”.**



Failures may occur if the auger is run full before it has been “polished” during the “break-in” period.



Be aware of any unusual vibration or noises during the initial start-up and “break-in” period. If anything unusual is detected, immediately shut down the auger and disconnect and lock out the power supply before servicing. Visually inspect the auger periodically during operation.

A. Operation for 6" systems

1. Start the unloading auger.
2. The safety snap pin should be inserted through the center well control rod and the control lever. Make sure it has NOT been inserted through the intermediate well control rod. (See Figure 6A.)
3. Place control lever in the second slot and pull lever to open gradually until the desired flow is established. (See Figure 6A.) It should not be necessary to open the gate more than 3" to 6".
4. Always close well gates and allow the unloader to clean out before stopping the unloader. Do not open the gate more than 3"-6" as the flow of grain into the center well will be at a higher rate than what the unload system can remove. This will cause the auger to plug or jam.

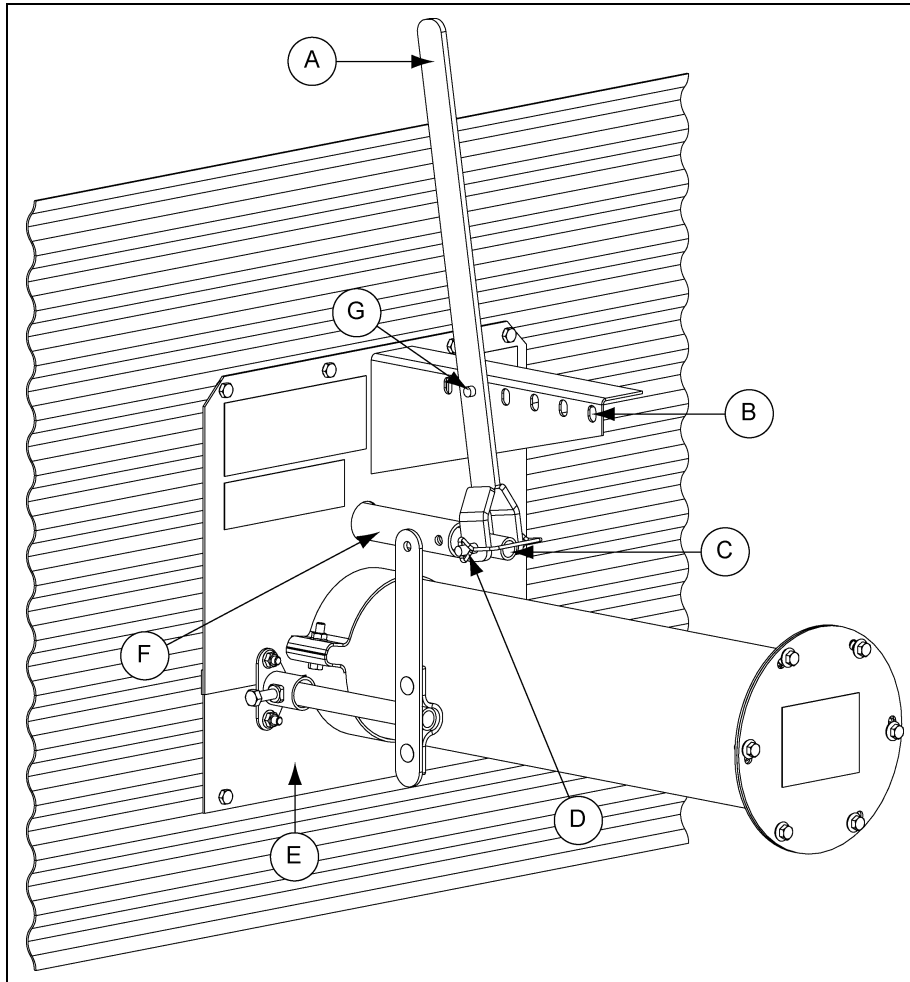

Figure 6A

Ref #	Description
A	Control Lever
B	Last Pivot Slot
C	Center Well Control Rod
D	Safety Snap Pin

Ref #	Description
E	Upper Bin Flange
F	Intermediate Well Control Rod
G	Second (2 nd) Slot

6. Operation

5. When grain flow stops from the center well, close the center well gate. Insert the safety snap pin through the control lever and both the intermediate and center well control rods as [Figure 6C](#). The remaining grain should look similar to [Figure 6B](#).

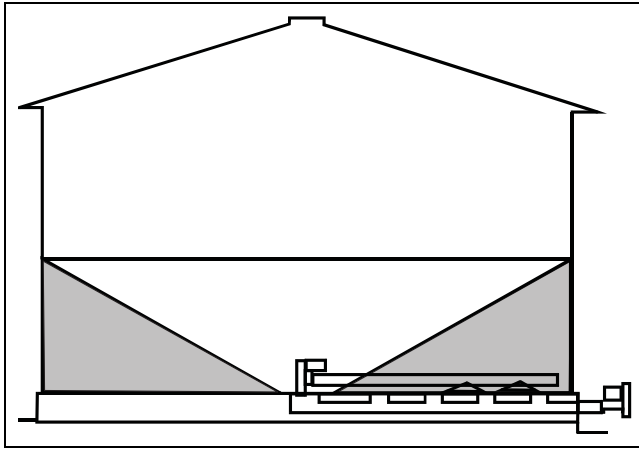

Figure 6B

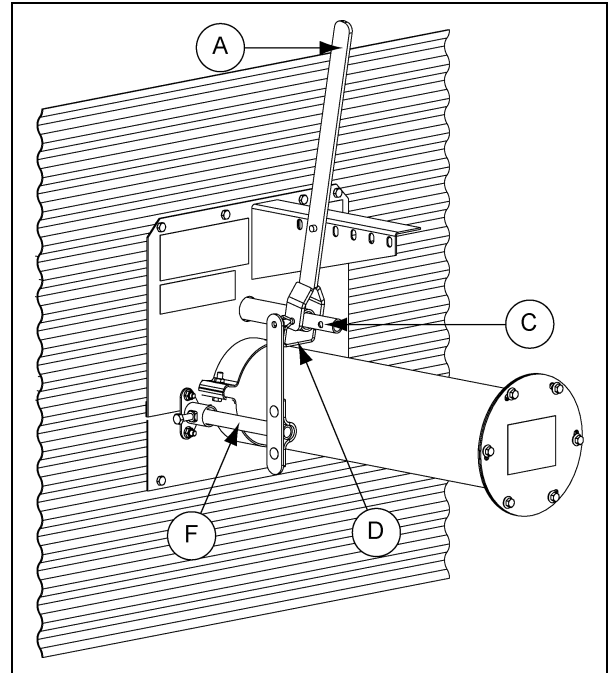

Figure 6C

Ref #	Description
A	Control Lever
C	Center Well Control Rod

Ref #	Description
D	Safety Snap Pin
F	Intermediate Well Control Rod

6. Gradually open gates using the middle pivot slot until the desired flow of grain is reached. You should not open the gates more than 2" to 4". If gates need to be opened further, use the last slot for more leverage. (See [Figure 6A on Page 43](#).) The remaining grain should look similar to [Figure 6D](#).

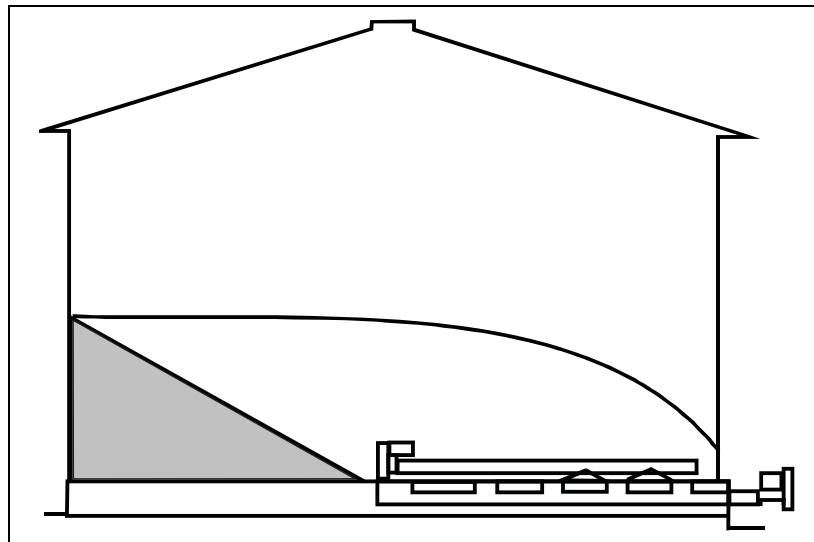

Figure 6D

B. For 8" and 10" systems

1. Start the unloading auger. The motor is located on the power head outside the bin on the unload tube. To find the horsepower needed for the equipment, use the horsepower chart on [Page 41](#).
2. Make sure the center well bolt is inserted through the rack and pinion tube and center well control rod. Make sure the intermediate well control rod is not attached to the center well control rod. (See [Figure 6E](#).)

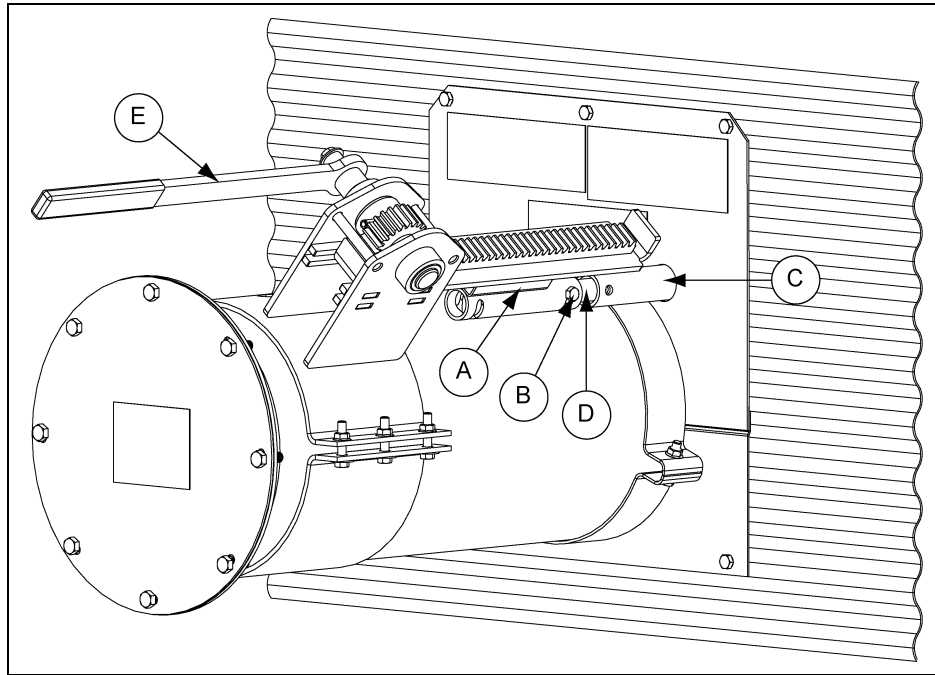

Figure 6E

Ref #	Description
A	Rack and Pinion Tube
B	Center Well Bolt
C	Intermediate Well Control Rod
D	Center Well Control Rod
E	Well Control Wrench

3. Using the wrench on rack and pinion, open center gate until desired flow is established. It should not be necessary to open gate more than 3" to 6". Do not open the gate more than 3" to 6" as the flow of grain into the center well will be at a higher rate than what the unload system can remove. This will cause auger to plug or jam.
4. Always close the well gates and allow the unloader to clean out before stopping the unloader.
5. When grain flow stops from the center well, close the center well gate. Insert the intermediate well bolt through the intermediate well control rod and the center well control rod. Remaining grain should look like [Figure 6B on Page 44](#).
6. Gradually open the gates until the desired flow of grain is reached. You should not open the gate more than 2" to 4". The remaining grain should look like [Figure 6D on Page 44](#).

6. Operation

Engaging the Clutch for Bin Sweep

1. All power should be OFF and locked out before starting.
2. Loosen the clutch control pipe position lock bolt. Pull on the clutch handle away from the bin to engage the clutch. Verify that the clutch is fully engaged, observing the distinguishing mark on the control rod, as done in before filling the bin.
3. Once the clutch has been engaged, tighten the clutch control pipe position lock bolt to hold the clutch control rod in the engaged position. (See Figure 6F.)



The center well gate must be FULLY open during the bin sweep operation.

4. Restore power and start the power sweep motor. The sweep auger will start along with the unload auger. The sweep auger will remain on the floor and clear most of the grain in one pass. A second pass will clean out additional grain, before final clean out.

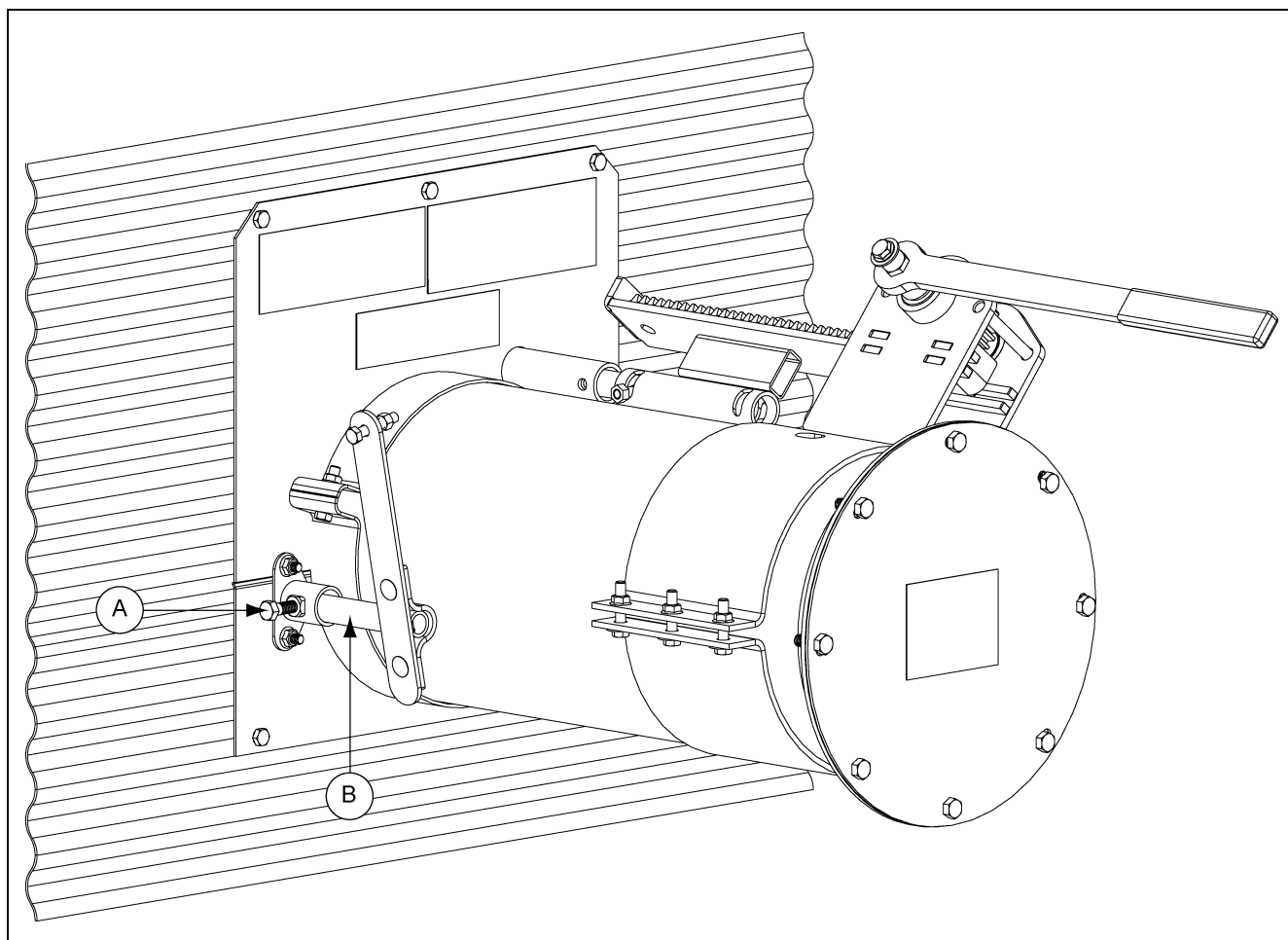

Figure 6F

Ref #	Description
A	Lock Collar Set Screw
B	Slide clutch control handle out to engage clutch.

Final Clean Out

The following procedure is recommended for cleaning the floor of the bin after the sweep auger has removed as much grain as possible.



DO NOT enter a grain bin unless all power driven equipment has been shut down and locked out.

1. Clean (scoop and sweep by hand) the outer area of the floor into a circular pile towards the center of the bin. (See Figure 6G.)
2. Get out of the bin.
3. After making sure everyone is outside the bin and clear of the equipment, start the under floor unloader and the sweep auger. In a short time, the circular pile towards the center of the bin will have been removed.
4. Stop the equipment and lock out.
5. Scoop and sweep by hand the remaining floor area to the center of the bin.
6. Get out of the bin.
7. Repeat [Steps 3-6](#) until all grain has been removed from the bin.

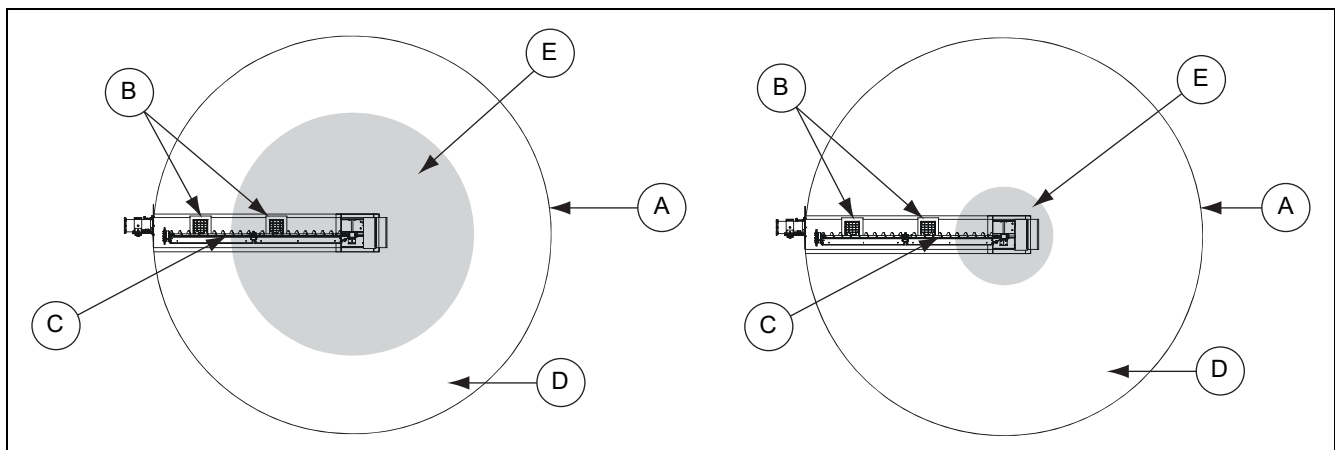

Figure 6G Top View of Bin

Ref #	Description
A	Bin Wall
B	Bin Wells
C	Sweep Auger

Ref #	Description
D	Cleaned Area
E	Remaining Grains



Keep out of bin while sweep is in operation. Rapidly traveling sweep auger. The sweep auger will move rapidly around the bin when the bin is nearly empty.



Stay clear of the under floor unloader at the bin wells. The under floor unloader is exposed at these locations in the bin floor.

7. Shut Down

Normal Shut Down

1. Before shutting down the unit, be sure the hoppers and augers are empty.
2. Disconnect and lock out the power source before leaving the work area.

Emergency Shut Down

1. Know how to shut down the auger in case of an emergency.
2. Do not restart the auger while it is under load.



NEVER start the equipment under load. Doing so may cause damage. This type of damage is considered a misuse of the equipment. Any misuse of the equipment may void the warranty.

3. Close the bin well control gates.
4. Re-connect and unlock the power source.
5. Clear the auger gradually, until there is no grain and there are no obstructions.

Storage Preparation

1. Close all wells to the discharge auger.
2. Position the direct gear drive sweep directly over the intermediate wells.

NOTE: *Make sure that the clutch control rods are disengaged.*

3. Be sure the unload tube is empty.
4. Shut down the auger.
5. Make sure all fasteners are tight.



DO NOT enter the grain bin unless all power driven equipment has been shut down.

Maintaining the Auger



*Properly maintaining this equipment will help to ensure it continues to work properly. Failure to properly maintain this equipment may result in damage to the equipment or may cause **SERIOUS INJURY** or **DEATH** to the operator.*

Failure to properly maintain this equipment may also be a misuse of the equipment. Any misuse of the equipment may void the warranty.

1. The U-joint must be lubricated with SAE multipurpose grease every 10 operational hours or after each use.
2. The upper and lower gearboxes in the center well should be half-full with oil. They must be checked and possibly filled with SAE 80W90 gear oil every 10 operational hours. Each gearbox should be filled up to the fill plug, approximately making them half-full overall. It is recommended to replace the oil in the gearboxes every season.
3. Use caution when repairing or replacing equipment parts.
4. Make sure ALL decals are legible and tightly attached to the auger. If necessary, replace them **FREE OF CHARGE** by contacting the dealer, warehouse or the manufacturer.
5. Mount controls for any electric motors at a safe distance from the machine and in a location accessible in case of an emergency.
6. Make sure ALL electrical wiring is not damaged and that it meets proper wiring codes.
7. Make sure ALL components are in good working condition before use.

NOTES

1. **Center Well Parts** - *(See Pages 52 and 53.)*
2. **Shaft Assembly** - *(See Page 54.)*
3. **Center Connection Parts** - *(See Page 55.)*
4. **6" Intermediate Well Parts** - *(See Pages 56 and 57.)*
5. **8" Intermediate Well Parts** - *(See Pages 58 and 59.)*
6. **10" Intermediate Well Parts** - *(See Pages 60 and 61.)*
7. **6" Bin Flange Parts** - *(See Page 62.)*
8. **8" Bin Flange Parts** - *(See Page 63.)*
9. **10" Bin Flange Parts** - *(See Page 64.)*
10. **6" Well Gate Control Parts** - *(See Page 66.)*
11. **8" and 10" Rack and Pinion** - *(See Pages 68 and 69.)*
12. **Assembled Sweep Arm Components** - *(See Pages 70 and 71.)*
13. **6", 8" and 10" Flight and Shield Bundle** - *(See Page 72.)*
14. **Spacer Plates for Reduction Drive Wheel** - *(See Page 73.)*
15. **Reduction Wheel Drive Components** - *(See Pages 74 and 75.)*

Center Well Parts

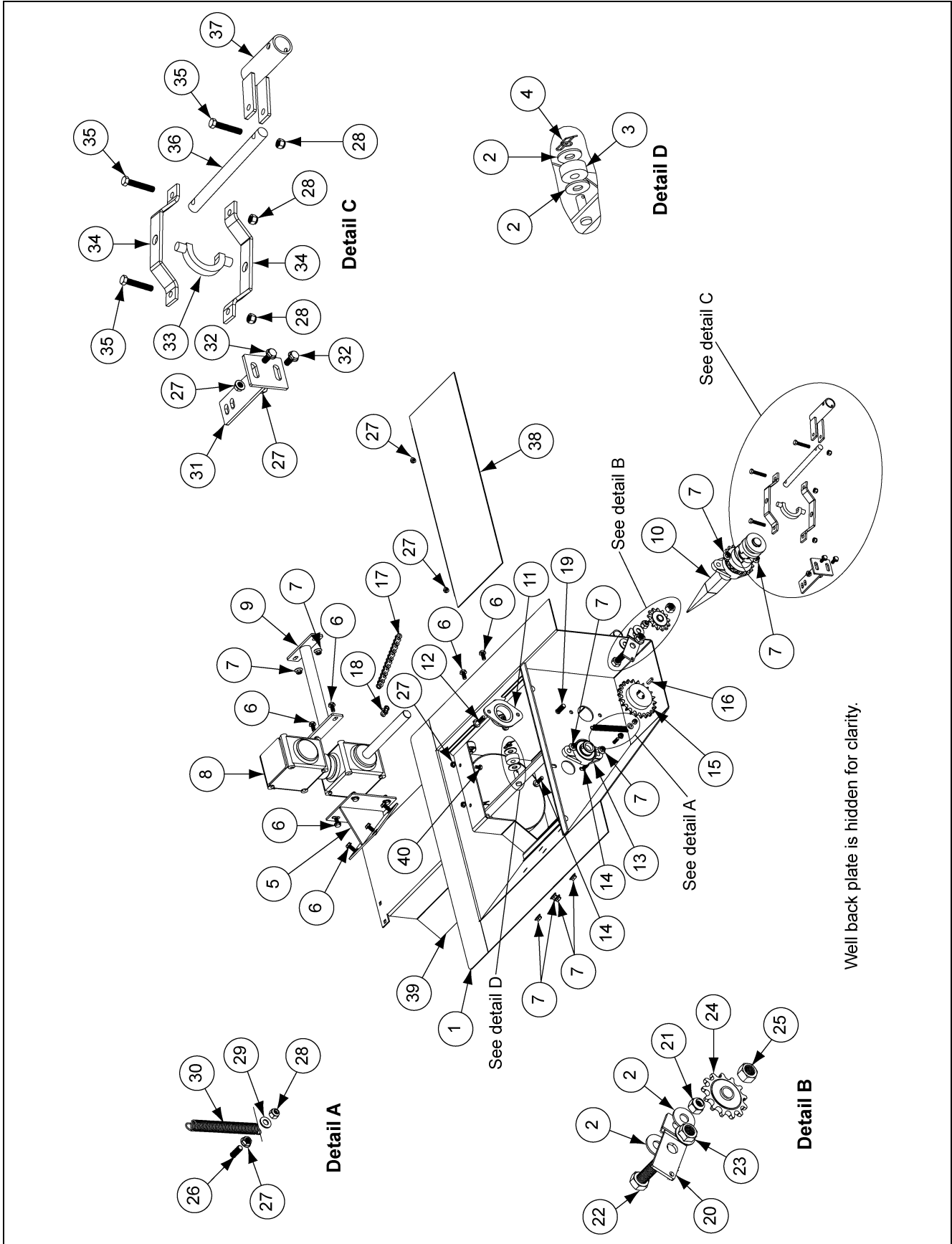

Well back plate is hidden for clarity.

Center Well Parts List

Ref #	Part #	Description	Ref #	Part #	Description
1	GK7231	Center Well - 6"	19	S-8760	1/2"-13 x 1-1/2" HHCS Bolt Zinc Grade 5
	GK7230	Center Well - 8"	20	GK1702	Idler Sprocket Pivot Bracket
	GK7227	Center Well - 10"	21	S-8260	1/2"-13 Nylock Nut Zinc Grade 5
2	S-2121	1/2" Flat Washer Plated, 9/16" I.D. x 1/10" x 1-3/8" O.D.	22	S-8399	5/8"-11 x 2" HHTB Bolt Zinc Grade 5
3	GC03064	1-1/2" O.D. x 5/8" Polyurethane Roller	23	S-9529	5/8"-11 Serrated Flange Nut Zinc
4	S-9422	1/2" Cotter Pin	24	GK1701	13 Tooth Idler Sprocket, 5/8" Bore, #50 with Bearing
5	GK1689	Offset Mounting Bracket - 6" and 8"	25	S-6494	5/8"-11 Deformed Lock Nut Zinc Grade 5
	GK4429	Offset Mounting Bracket - 10"	26	S-7470	5/16"-18 x 1" Flange Bolt Zinc Grade 5
6	S-9067	3/8"-16 x 3/4" Serrated Flange Bolt Zinc Grade 5	27	S-3611	5/16"-18 Serrated Flange Nut YDP Grade 2
7	S-968	3/8"-16 Serrated Flange Nut Zinc Grade 5	28	S-7382	5/16"-18 Nylock Nut Zinc Grade 5
8	GK80187	Gearbox with Clockwise Rotation	29	S-1937	5/16" Flat Washer Zinc Grade 2
9	GK1688	Gearbox Mounting Bracket - 6" and 8"	30	GK1704	Spring, Idler Bracket 5" Zinc 1/16" Pitch
	GK4430	Gearbox Mounting Bracket - 10"	31	GK1693	Clutch Pivot Bracket
10	GK7089	Center Well Shaft Assembly - 6" and 8"	32	S-6606	5/16"-18 x 3/4" Serrated Flange Bolt Zinc Grade 5
	GK7090	Center Well Shaft Assembly - 10"	33	GK1698	Clutch Yoke
11	GK7886	Clutch Shaft Support Collar - 6" and 8"	34	GK1697	Clutch Yoke Bracket
	GK7885	Clutch Shaft Support Collar - 10"	35	S-7149	5/16"-18 x 1-3/4" HHTB Bolt Zinc Grade 5
12	S-9064	3/8"-16 x 1-1/2" Serrated Flange Bolt Zinc Grade 5	36	GK1695	Clutch Connection Rod
13	GK4410	Flange Bearing, 1" Bore, 2 Hole with Lock Collar	37	GK1694	Clutch Control Arm - 6" and 8"
14	S-9066	3/8"-16 x 1-1/4" Serrated Flange Bolt Zinc Grade 5		GK1923	Clutch Control Arm - 10"
15	GK1110	22 Tooth, Sprocket, 1" Bore, #50 with Keyway	38	GK7229	Center Well Drive Cover Plate - 6" and 8"
16	S-9168	1/4" Square x 1" Key		GK7228	Center Well Drive Cover Plate - 10"
17	GK1705	43P #50 Roller Chain - 6" and 8"	39	GK7226	Slide Gate - 6" and 8"
	GK6830	47P #50 Roller Chain - 10"		GK7224	Slide Gate - 10"
18	D32-0015	Connecting Link #50 Roller Chain	40	S-8999	5/16"-18 x 1/2" HHCS Bolt Zinc Grade 5

Shaft Assembly

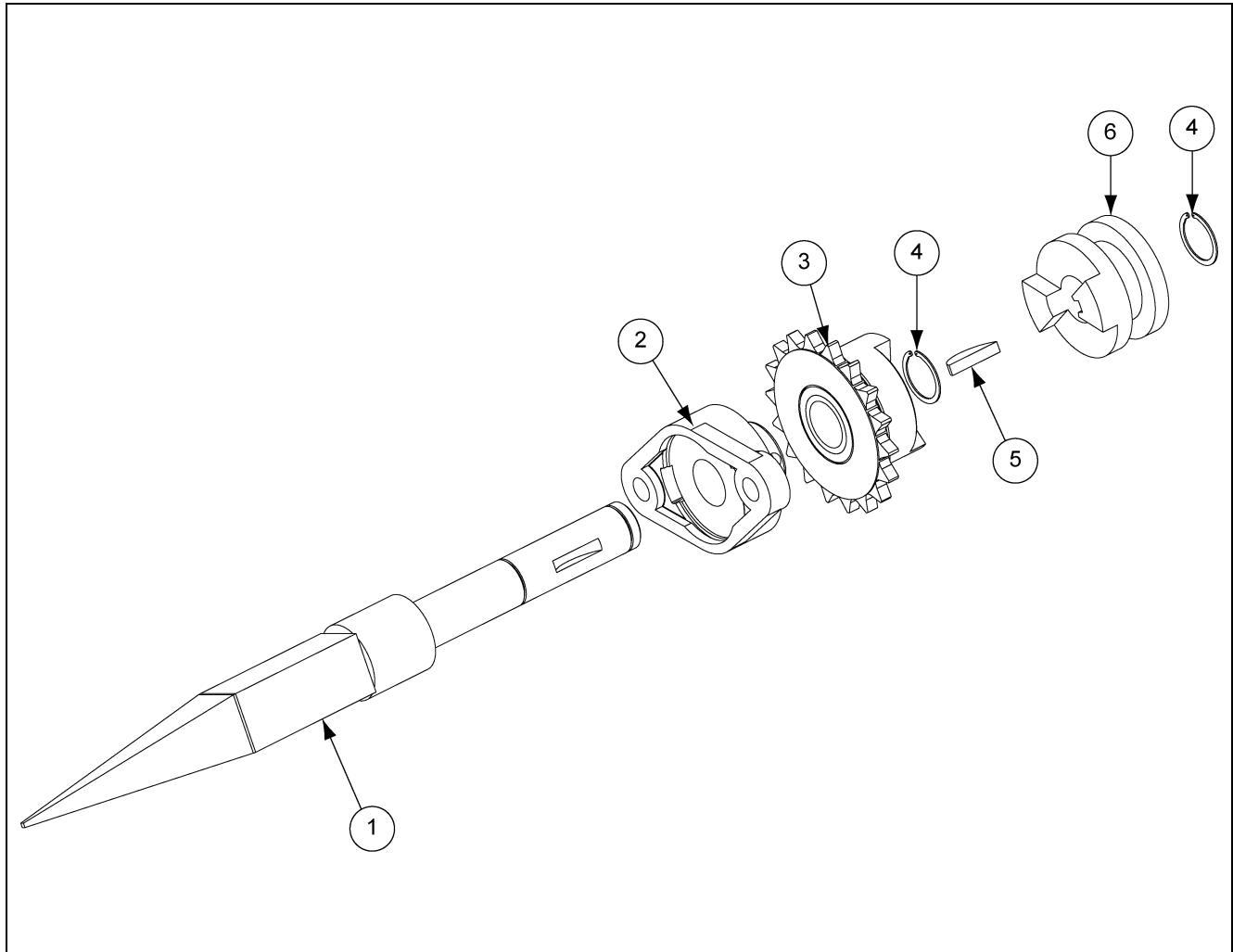

Shaft Assembly Parts List

Ref #	Part #	Description
1	GK6698	Center Well Square Shaft - 6" and 8"
	GK6699	Center Well Square Shaft - 10"
2	GK4410	Flange Bearing, 1" Bore, 2 Hole with Lock Collar
3	GK1699	13 Tooth Clutch Yoke Driver Jaw - 6" and 8"
	GK6809	18 Tooth Clutch Yoke Driver Jaw - 10"
4	S-8902	1" O.D. x 15/16" I.D. Groove Snap Ring
5	S-8901	1/4" x 1/4" #21 Woodruff Key
6	GK1696	Clutch Yoke Driven Sliding Jaw

Center Connection Parts

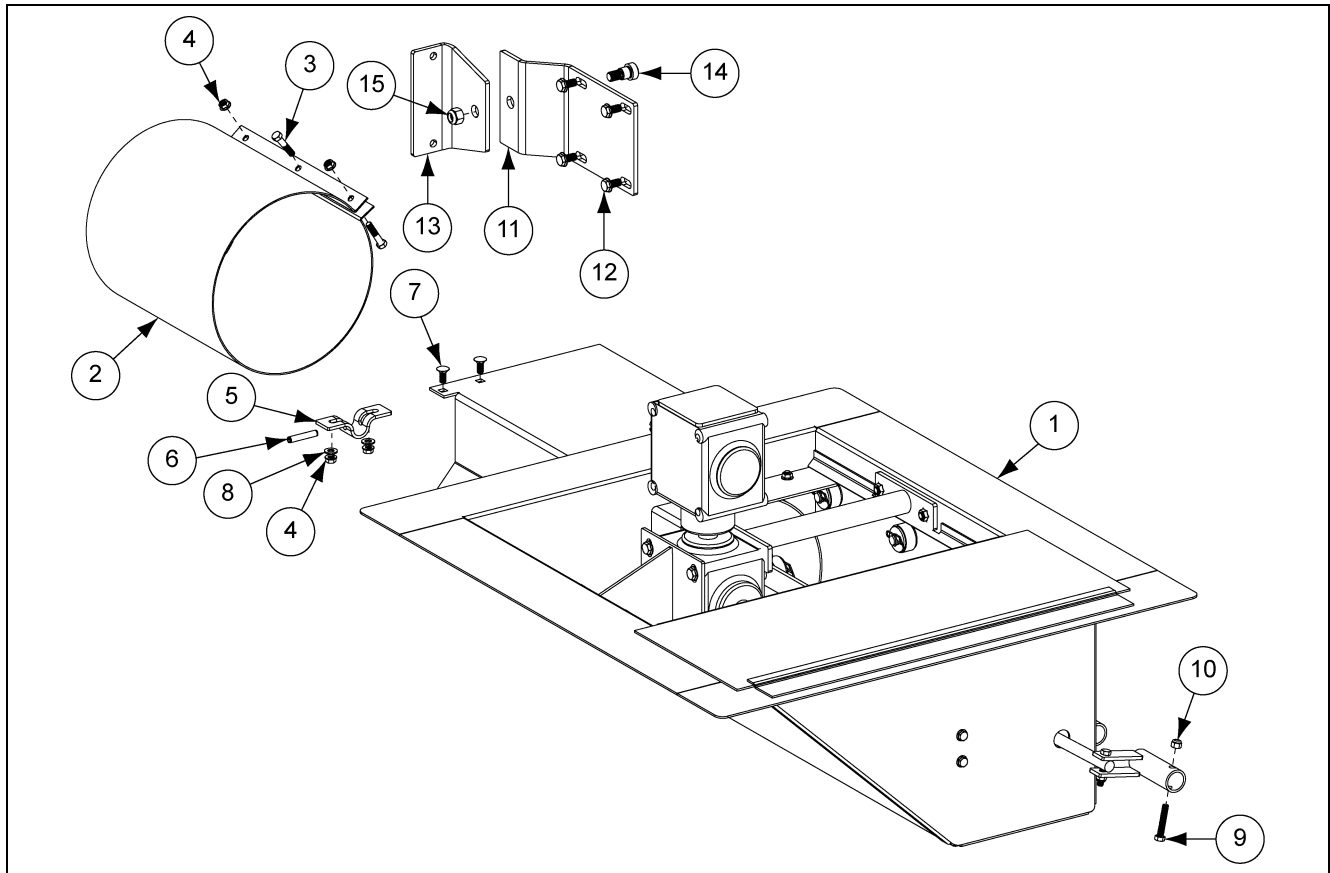

Center Connection Parts List

Ref #	Part #	Description
1	GK7129	Center Well Assembly - 6"
	GK7130	Center Well Assembly - 8"
	GK7131	Center Well Assembly - 10"
2	GK1624	Connecting Band - 6"
	GK1677	Connecting Band - 8"
	GK1796	Connecting Band - 10"
3	S-2741	5/16"-18 x 1-1/2" HHCS Bolt Zinc Grade 5
4	S-3611	5/16"-18 Serrated Flange Nut YDP Grade 2
5	GK1726	1/2" Control Rod Clamp
6	S-8397	5/16" x 1-3/4" Spring Pin
7	S-6076	5/16"-18 x 3/4" Carriage Bolt Zinc Grade 2
8	S-1937	5/16" Flat Washer Zinc Grade 2
9	S-7149	5/16"-18 x 1-3/4" HHTB Bolt Zinc Grade 5
10	S-7382	5/16"-18 Nylock Nut Zinc Grade 5
11	GK4460	Gearbox Pivot Bracket
12	S-9067	3/8"-16 x 3/4" Serrated Flange Bolt Zinc Grade 5
	GK6175	Shield Mounting Bracket - 6" and 8"
13	GK4461	Shield Mounting Bracket - 10"
	S-10110	1/2"-13 x 1/2" Shoulder Bolt
14	S-10110	1/2"-13 x 1/2" Shoulder Bolt
15	S-8260	1/2"-13 Nylock Nut Zinc Grade 5

6" Intermediate Well Parts

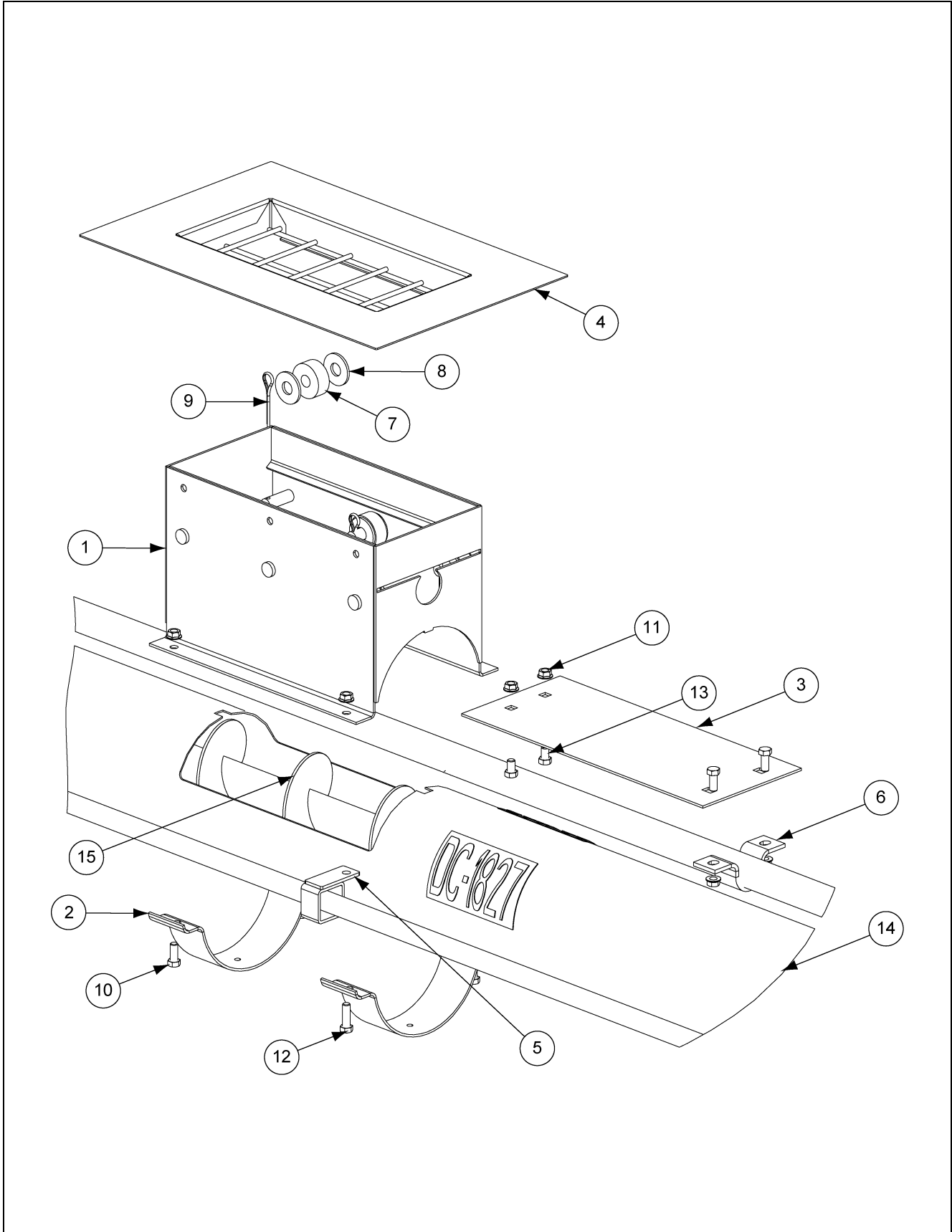

6" Intermediate Well Parts List

Ref #	Part #	Description
1	GC10126	6" Intermediate Well Weldment
2	GK1053	6" Half Band
3	GK6756	6" Intermediate Well Gate
4	GK6757	6" Intermediate Well Top Flange
5	GK6713	6" Control Rod Guide
6	GC00174	Control Gate Clamp with Dimple for 6" and 8"
7	GC03064	1-1/2" O.D. x 5/8" Polyurethane Roller
8	S-2121	1/2" Flat Washer Plated, 9/16" I.D. x 1/10" x 1-3/8" O.D.
9	S-7241	1/8" x 1-1/4" Cotter Pin Zinc Grade 2
10	S-4275	5/16"-18 x 3/4" HHTB Bolt Zinc Grade 5
11	S-3611	5/16"-18 Serrated Flange Nut YDP Grade 2
12	S-1196	5/16"-18 x 1" HHCS Bolt Grade 5
13	S-8999	5/16"-18 x 1/2" HHCS Bolt Zinc Grade 5

Tube (14)

Part #	Description
GK6890	6" x 15' Bin 12" Well
GK6891	6" x 18' Bin 12" Well
GK6892	6" x 21' Bin 12" Well
GK6893	6" x 24' Bin 12" Well
GK6894	6" x 27' Bin 12" Well
GK6895	6" x 30' Bin 12" Well
GK6896	6" x 33' Bin 12" Well
GK6897	6" x 36' Bin 12" Well

Flight (15)

Part #	Description
GK7020	6" x 121-1/4" 15' Bin
GK7021	6" x 145-1/4" 18' Bin
GK7022	6" x 157-1/4" 21' Bin
GK7023	6" x 175-1/4" 24' Bin
GK7024	6" x 193-1/4" 27' Bin
GK7025	6" x 211-1/4" 30' Bin
GK7026	6" x 235-1/4" 33' Bin
GK7027	6" x 247-1/4" 36' Bin

8" Intermediate Well Parts

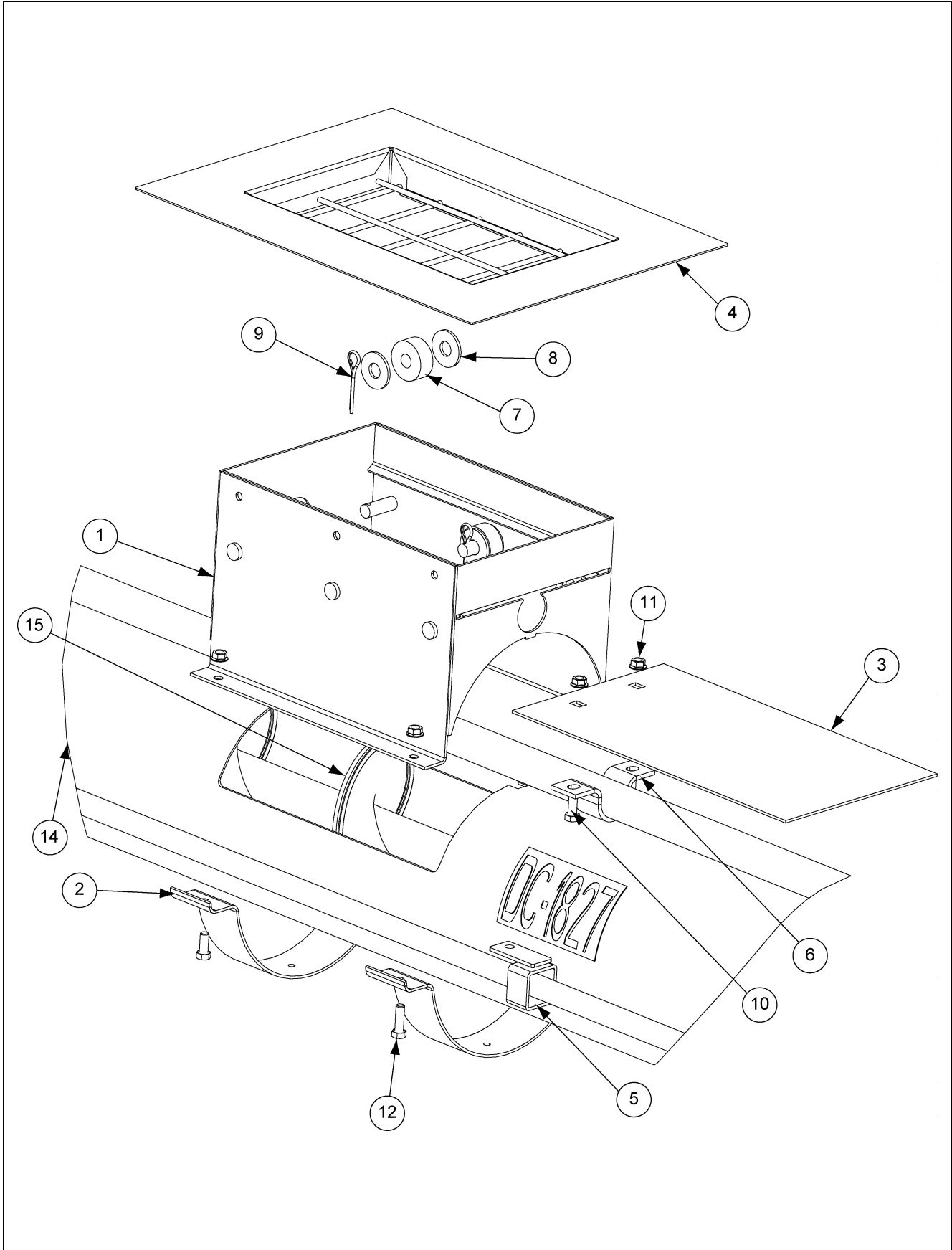

8" Intermediate Well Parts List

Ref #	Part #	Description
1	GC10129	8" Intermediate Well Weldment
2	GK1055	8" Half Band
3	GK6759	8" Intermediate Well Gate
4	GK6760	8" Intermediate Well Top Flange
5	GK6711	8" Control Rod Guide
6	GC00174	Control Gate Clamp with Dimple for 6" and 8"
7	GC03064	1-1/2" O.D. x 5/8" Polyurethane Roller
8	S-2121	1/2" Flat Washer Plated, 9/16" I.D. x 1/10" x 1-3/8" O.D.
9	S-7241	1/8" x 1-1/4" Cotter Pin Zinc Grade 2
10	S-4275	5/16"-18 x 3/4" HHTB Bolt Zinc Grade 5
11	S-3611	5/16"-18 Serrated Flange Nut YDP Grade 2
12	S-1196	5/16"-18 x 1" HHCS Bolt Grade 5

Tube (14)

Part #	Description
GK6899	8" x 15' Bin 12" Well
GK6900	8" x 18' Bin 12" Well
GK6901	8" x 21' Bin 12" Well
GK6902	8" x 24' Bin 12" Well
GK6903	8" x 27' Bin 12" Well
GK6904	8" x 30' Bin 12" Well
GK6905	8" x 33' Bin 12" Well
GK6906	8" x 36' Bin 12" Well
GK6907	8" x 39' Bin 12" Well
GK6908	8" x 42' Bin 12" Well
GK6909	8" x 48' Bin 12" Well

Flight (15)

Part #	Description
GK7028	8" x 121-1/4" 15' Bin
GK7029	8" x 145-1/4" 18' Bin
GK7030	8" x 157-1/4" 21' Bin
GK7031	8" x 175-1/4" 24' Bin
GK7032	8" x 193-1/4" 27' Bin
GK7033	8" x 211-1/4" 30' Bin
GK7034	8" x 235-1/4" 33' Bin
GK7035	8" x 247-1/4" 36' Bin
GK7036	8" x 265-1/4" 39' Bin
GK7037	8" x 289-1/4" 42' Bin
GK7038	8" x 325-1/2" 48' Bin

10" Intermediate Well Parts

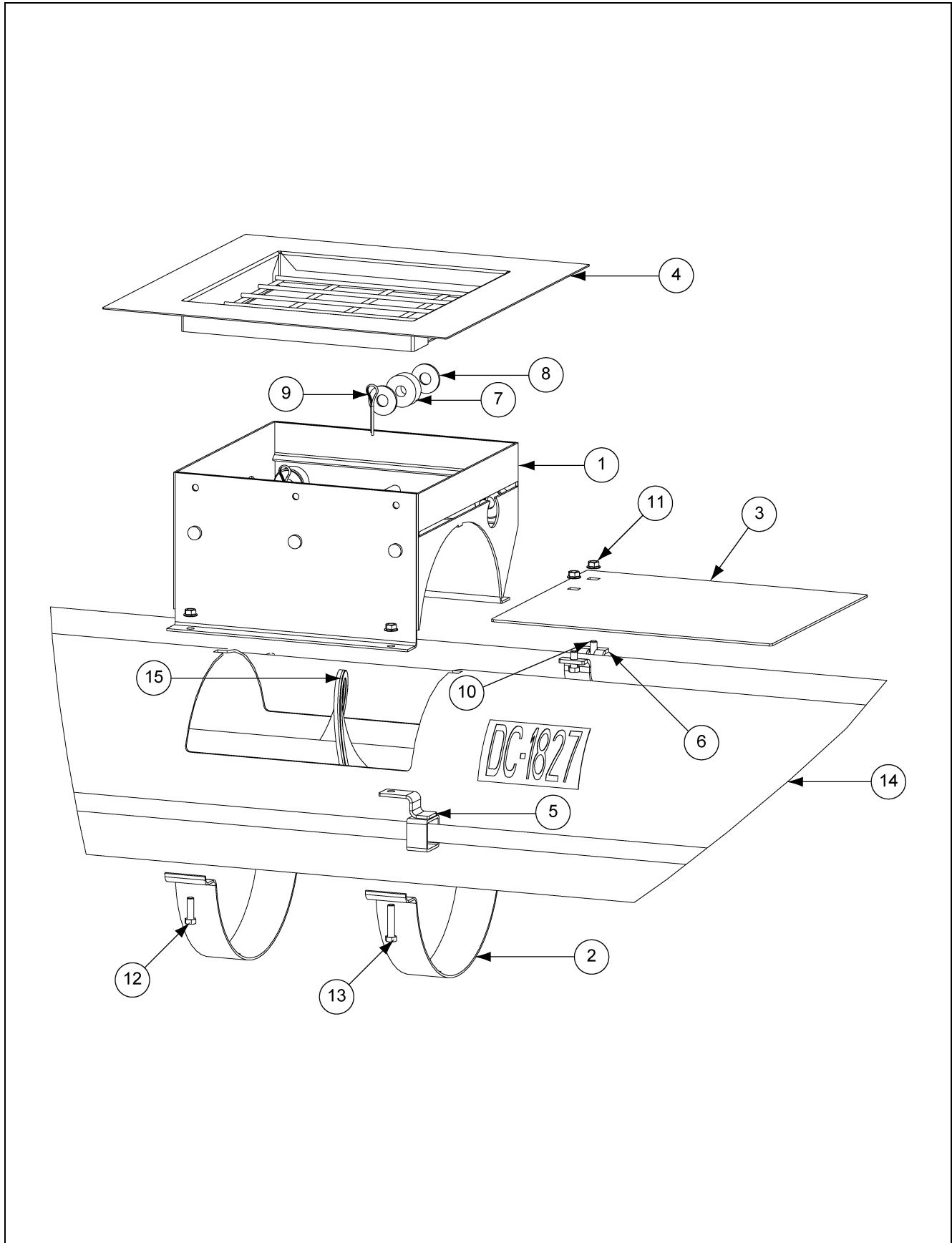

10" Intermediate Well Parts List

Ref #	Part #	Description
1	GC10131	Intermediate Well Weldment
2	GK1057	10" Half Band
3	GK6762	10" Intermediate Well Gate
4	GK6763	10" Intermediate Well Top Flange
5	GK6714	10" Control Rod Guide
6	GC09006	Control Pipe Clamp with Dimple
7	GC03064	1-1/2" O.D. x 5/8" Polyurethane Roller
8	S-2121	1/2" Flat Washer Plated, 9/16" I.D. x 1/10" x 1-3/8" O.D.
9	S-7241	1/8" x 1-1/4" Cotter Pin Zinc Grade 2
10	S-4275	5/16"-18 x 3/4" HHTB Bolt Zinc Grade 5
11	S-3611	5/16"-18 Serrated Flange Nut YDP Grade 2
12	S-1196	5/16"-18 x 1" HHCS Bolt Grade 5
13	S-2741	5/16"-18 x 1-1/2" HHCS Bolt Zinc Grade 5

Tube (14)

Part #	Description
GK6921	10" x 24' Bin 12" Well
GK6922	10" x 27' Bin 12" Well
GK6923	10" x 30' Bin 12" Well
GK6924	10" x 33' Bin 12" Well
GK6925	10" x 36' Bin 12" Well
GK6926	10" x 39' Bin 12" Well
GK6927	10" x 42' Bin 12" Well
GK6928	10" x 48' Bin 12" Well

Flight (15)

Part #	Description
GK7039	10" x 175-1/4" 24' Bin
GK7040	10" x 193-1/4" 27' Bin
GK7041	10" x 211-1/4" 30' Bin
GK7042	10" x 235-1/4" 33' Bin
GK7043	10" x 247-1/4" 36' Bin
GK7044	10" x 265-1/4" 39' Bin
GK7045	10" x 289-1/4" 42' Bin
GK7046	10" x 325-1/4" 48' Bin

6" Bin Flange Parts

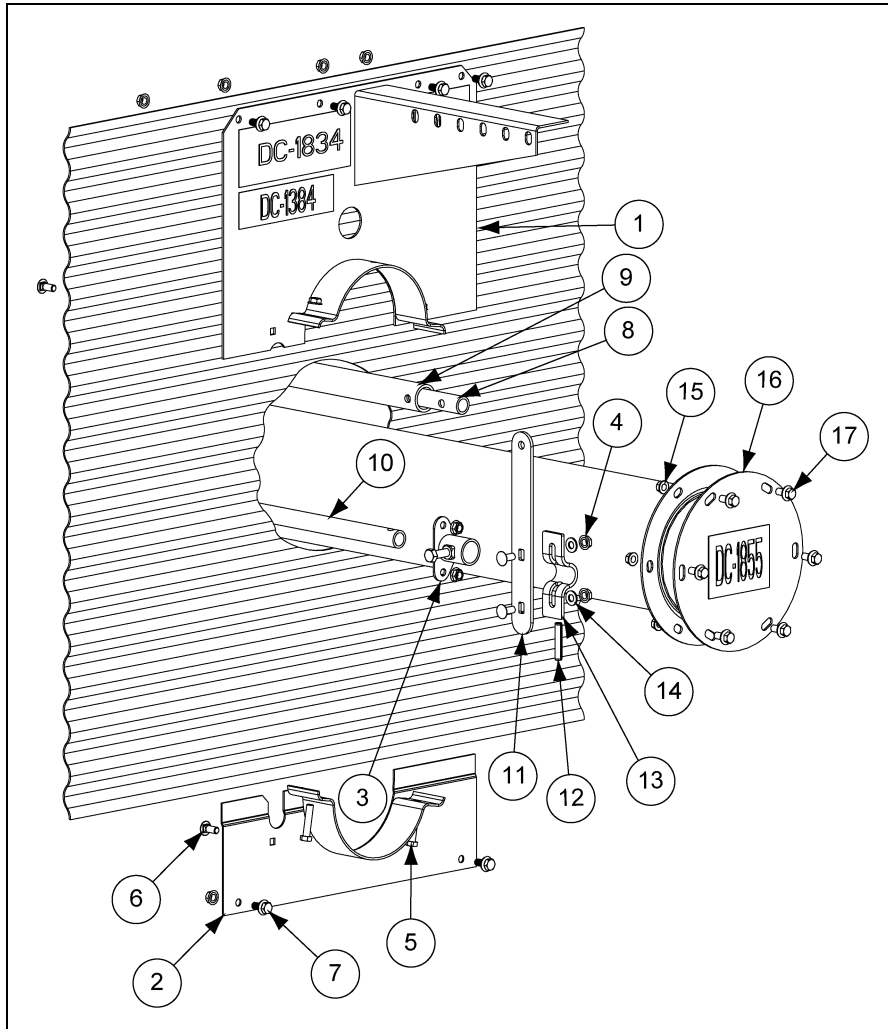

6" Bin Flange Parts List

Ref #	Part #	Description
1	GC10546	6" Top Bin Flange
2	GC10547	6" Bottom Bin Flange
3	GK1619	Clutch Control Rod Position Lock Flange
4	S-3611	5/16"-18 Serrated Flange Nut YDP Grade 2
5	S-2741	5/16"-18 x 1-1/2" HHCS Bolt Zinc Grade 5
6	S-6076	5/16"-18 x 3/4" Carriage Bolt Zinc Grade 2
7	S-275	5/16"-18 x 3/4" HH Bin Bolt YDP Grade 5
8		See Page 65
9		See Page 65
10		See Page 65
11	GC12074	Clutch Control Rod Handle
12	S-8397	5/16" x 1-3/4" Spring Pin
13	GK1726	1/2" Control Rod Clamp
14	S-1937	5/16" Flat Washer Zinc Grade 2
15	S-3611	5/16"-18 Serrated Flange Nut YDP Grade 2
16	GK1206	6" End Cap
17	S-275	5/16"-18 x 3/4" HH Bin Bolt YDP Grade 5

8" Bin Flange Parts

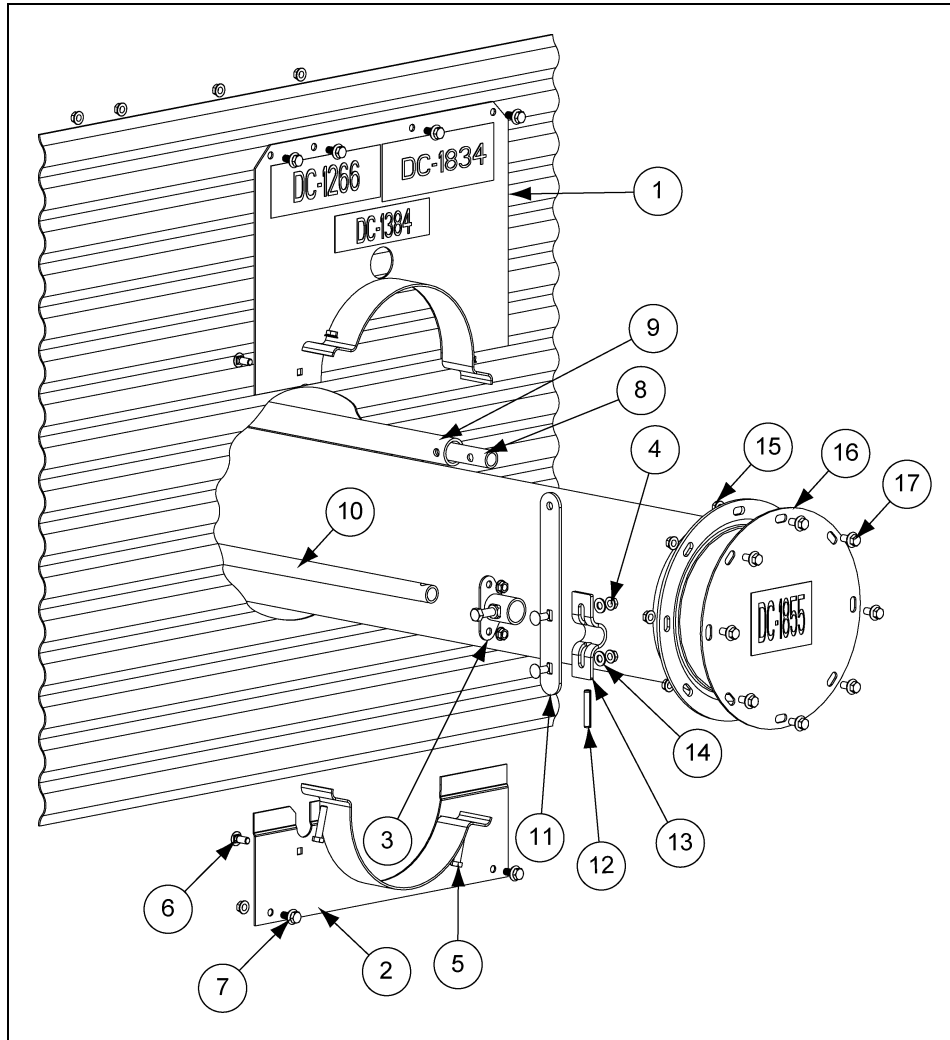

8" Bin Flange Parts List

Ref #	Part #	Description
1	GC10534	8" Top Bin Flange
2	GC10536	8" Bottom Bin Flange
3	GK1619	Clutch Control Rod Position Lock Flange
4	S-3611	5/16"-18 Serrated Flange Nut YDP Grade 2
5	S-2741	5/16"-18 x 1-1/2" HHCS Bolt Zinc Grade 5
6	S-6076	5/16"-18 x 3/4" Carriage Bolt Zinc Grade 2
7	S-275	5/16"-18 x 3/4" HH Bin Bolt YDP Grade 5
8		See Page 65
9		See Page 65
10		See Page 65
11	GC12074	Clutch Control Rod Handle
12	S-8397	5/16" x 1-3/4" Spring Pin
13	GK1726	1/2" Control Rod Clamp
14	S-1937	5/16" Flat Washer Zinc Grade 2
15	S-3611	5/16"-18 Serrated Flange Nut YDP Grade 2
16	GK1216	8" End Cap
17	S-275	5/16"-18 x 3/4" HH Bin Bolt YDP Grade 5

10" Bin Flange Parts

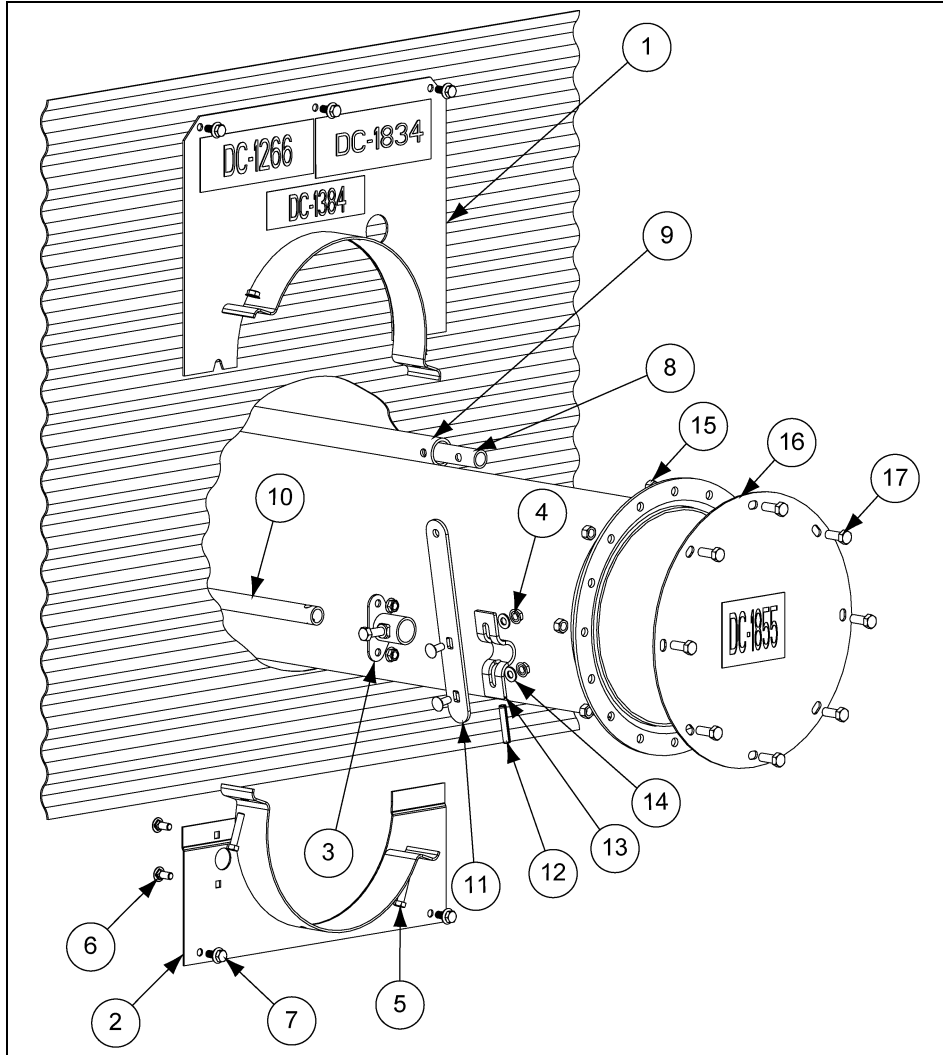

10" Bin Flange Parts List

Ref #	Part #	Description
1	GC10560	10" Top Bin Flange
2	GC10588	10" Bottom Bin Flange
3	GK1619	Clutch Control Rod Position Lock Flange
4	S-3611	5/16"-18 Serrated Flange Nut YDP Grade 2
5	S-2741	5/16"-18 x 1-1/2" HHCS Bolt Zinc Grade 5
6	S-6076	5/16"-18 x 3/4" Carriage Bolt Zinc Grade 2
7	S-275	5/16"-18 x 3/4" HH Bin Bolt YDP Grade 5
8		See Page 65
9		See Page 65
10		See Page 65
11	GC12074	Clutch Control Rod Handle
12	S-8397	5/16" x 1-3/4" Spring Pin
13	GK1726	1/2" Control Rod Clamp
14	S-1937	5/16" Flat Washer Zinc Grade 2
15	S-456	3/8"-16 Hex Nut YDP Grade 5
16	GK2184	10" End Cap
17	S-7469	3/8"-16 x 1" HHCS Bolt Zinc Grade 5

6", 8" and 10" Bin Flange Parts

Control Pipe

NOTE: All two (2) piece pipes assemble with GC05323; 3/8" NPT x 1.0" pipe connector.

Bin Size	Center Well Control Pipe (8)		Intermediate Well Control Pipe (9)			Clutch Control Pipe (10)	
	Part #	Description	6" Part #	8" or 10" Part #	Description	Part #	Description
15'	GC09110	0.840" O.D. x 7'	GC10360	GC11114	1" O.D. x 5' 1.851"	GK1709	0.840" O.D. x 10'
18'	GC09111	0.840" O.D. x 8' 6"	GC10359	GC11115	1" O.D. x 6' 10.475"	GK1720	0.840" O.D. x 11' 6"
21'	GC09112	0.840" O.D. x 10'	GC10358	GC11117	1" O.D. x 8' 6.824"	GK1730	0.840" O.D. x 13'
24'	GC09113	0.840" O.D. x 11' 6"	GC10357	GC11118	1" O.D. x 9' 8.726"	GK1744	0.840" O.D. x 14' 6"
27'	GC09114	0.840" O.D. x 13'	GC10356	GC11119	1" O.D. x 10' 8.726"	GK1749	0.840" O.D. x 16'
30'	GC09115	0.840" O.D. x 14' 6"	GC10355	GC11120	1" O.D. x 11' 8.726"	GK1754	0.840" O.D. x 17' 6"
33'	GC09116	0.840" O.D. x 16'	GC10354	GC11121	1" O.D. x 14' 1.664"	GK1761	0.840" O.D. x 19' 6"
36'	GC09117	0.840" O.D. x 17' 6"	GC10353	GC11122	1" O.D. x 515' 4.664"	GK1769	0.840" O.D. x 20' 6"
39'	GC09118	0.840" O.D. x 19'	-	GC11123	1" O.D. x 16' 6.164"	GK1766	0.840" O.D. x 1'
						GK1776	0.840" O.D. x 21'
42'	GC09119	0.840" O.D. x 20' 6"	-	GC11124	1" O.D. x 18' 8.226"	GK1784	0.840" O.D. x 2' 6"
						GK1776	0.840" O.D. x 21'
48'	GK1776	0.840" O.D. x 21'	-	GC11125	1" O.D. x 21'	GK1718	0.840" O.D. x 5' 6"
	GC09075	0.840" O.D. x 2' 6"				GK1776	0.840" O.D. x 21'

6" Well Gate Control Parts

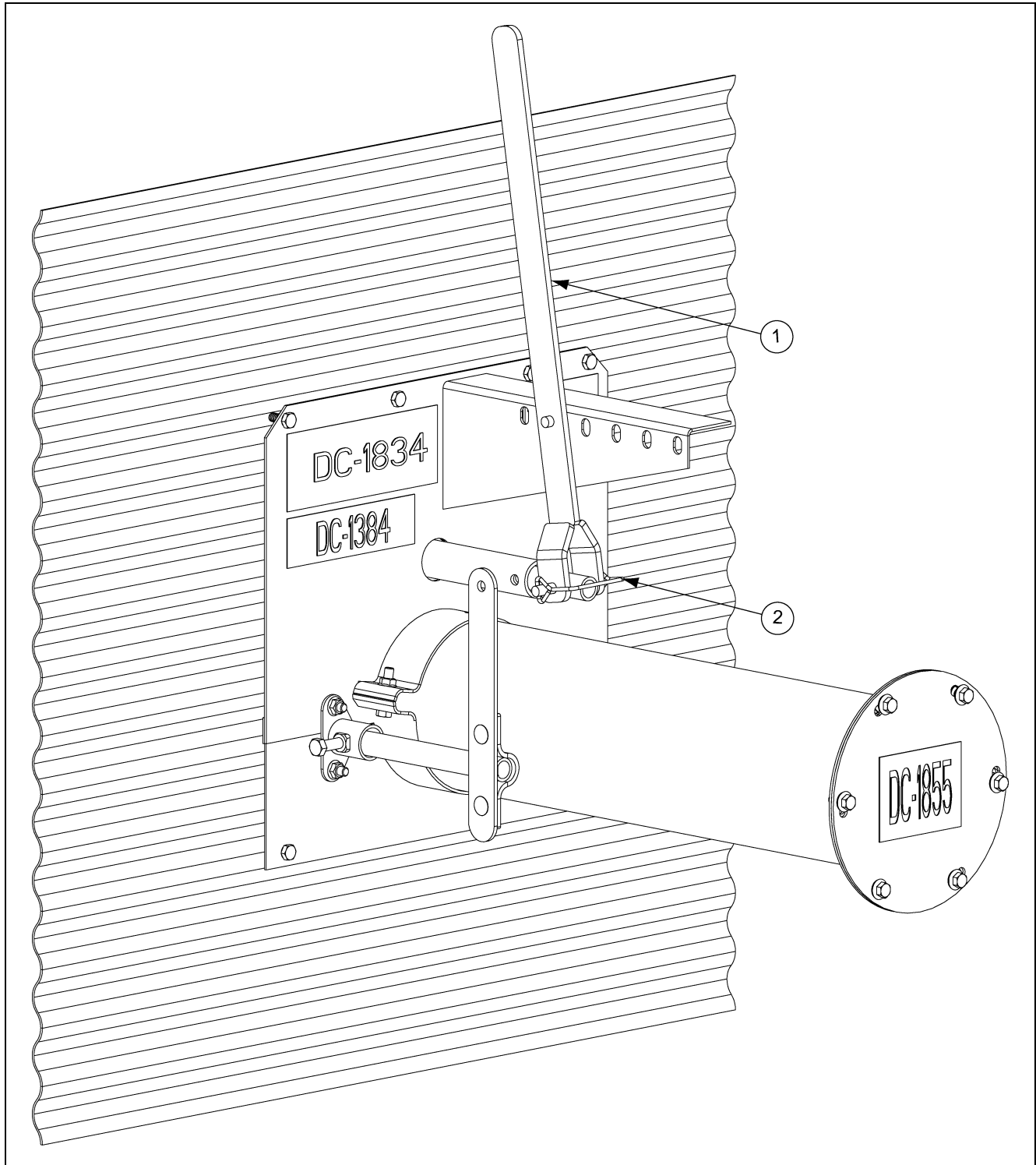

6" Well Gate Control Parts List

Ref #	Part #	Description
1	GK5063	6" Control Lever Handle Weldment
2	S-8480	3/8" x 2-3/4" Safety Snap Pin

NOTES

8" and 10" Rack and Pinion

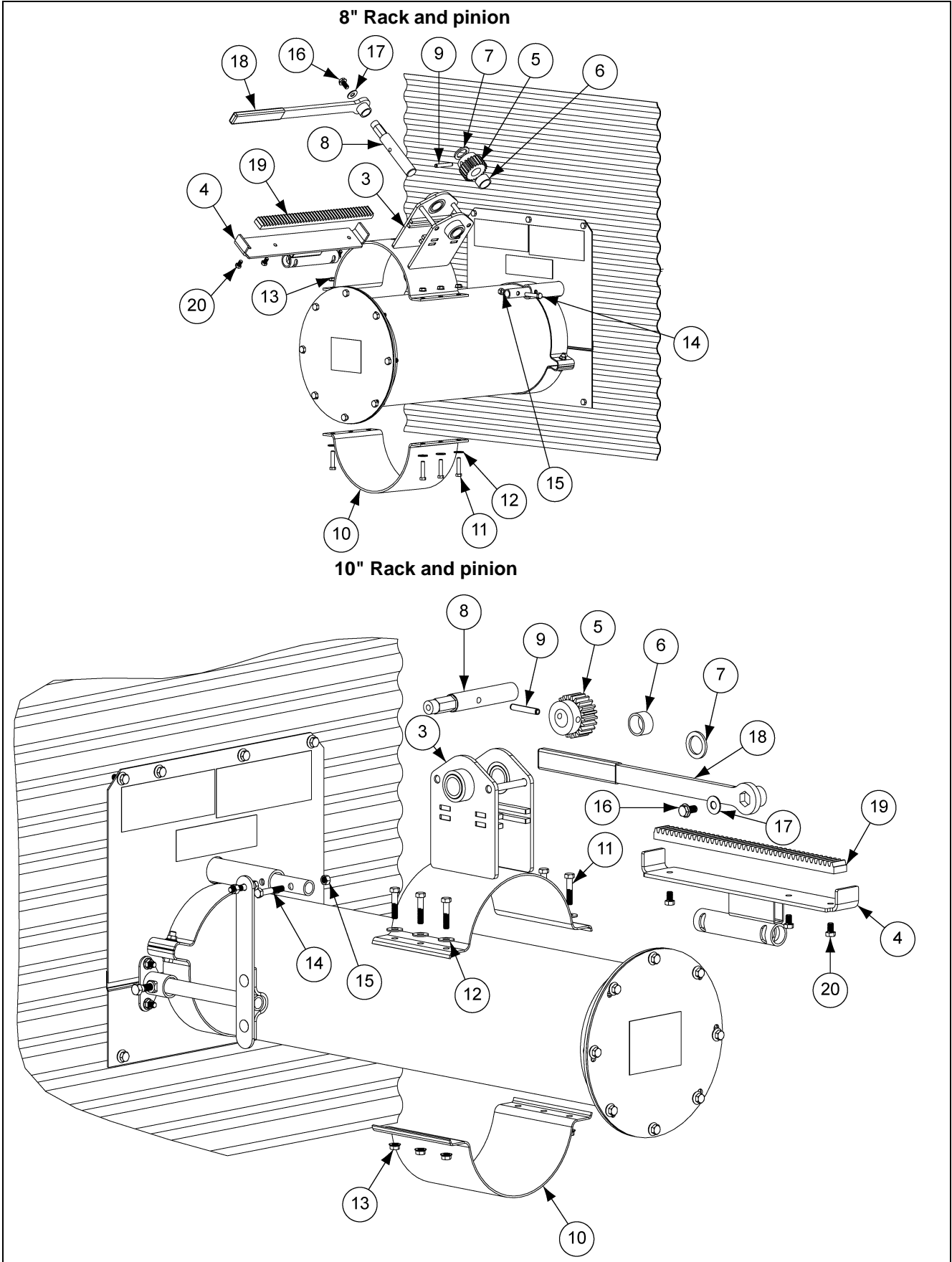

8" and 10" Rack and Pinion Parts List

Ref #	Part #	Description
3	GK6838	8" Rack and Pinion Housing Assembly
3	GK6966	10" Rack and Pinion Housing Assembly
4	GK80079	8" Rack and Pinion Body Assembly
4	GK80080	10" Rack and Pinion Body Assembly
5	GC09859	Spur Gear 10DP 1" Face 22T
6	GK6841	Rack and Pinion Spacer Tube
7	GK4211	1" I.D. x 1-1/2" O.D. Flat Washer 10 Gauge Zinc
8	GK6845	Rack and Pinion Crank Shaft
9	S-4377	5/16" x 2" Grooved Roll Pin
10	GK1603	8" Half Band
10	GK5116	10" Half Band
11	S-2741	5/16"-18 x 1-1/2" HHCS Bolt Zinc Grade 5
12	S-845	5/16" Flat Washer Zinc Grade 2
13	S-3611	5/16"-18 Serrated Flange Nut YDP Grade 2
14	S-7149	5/16"-18 x 1-3/4" HHTB Bolt Zinc Grade 5
15	S-396	5/16" Hex Nut Zinc Grade 2
16	S-9067	3/8"-16 x 3/4" Serrated Flange Bolt Zinc Grade 5
17	S-248	3/8" Flat Washer Zinc Grade 2
18	GK7260	3/4" Wrench Assembly
19	GC10316	Rack Bar 10P x 1" x 14"
20	S-8999	5/16"-18 x 1/2" HHCS Bolt Zinc Grade 5

Assembled Sweep Arm Components

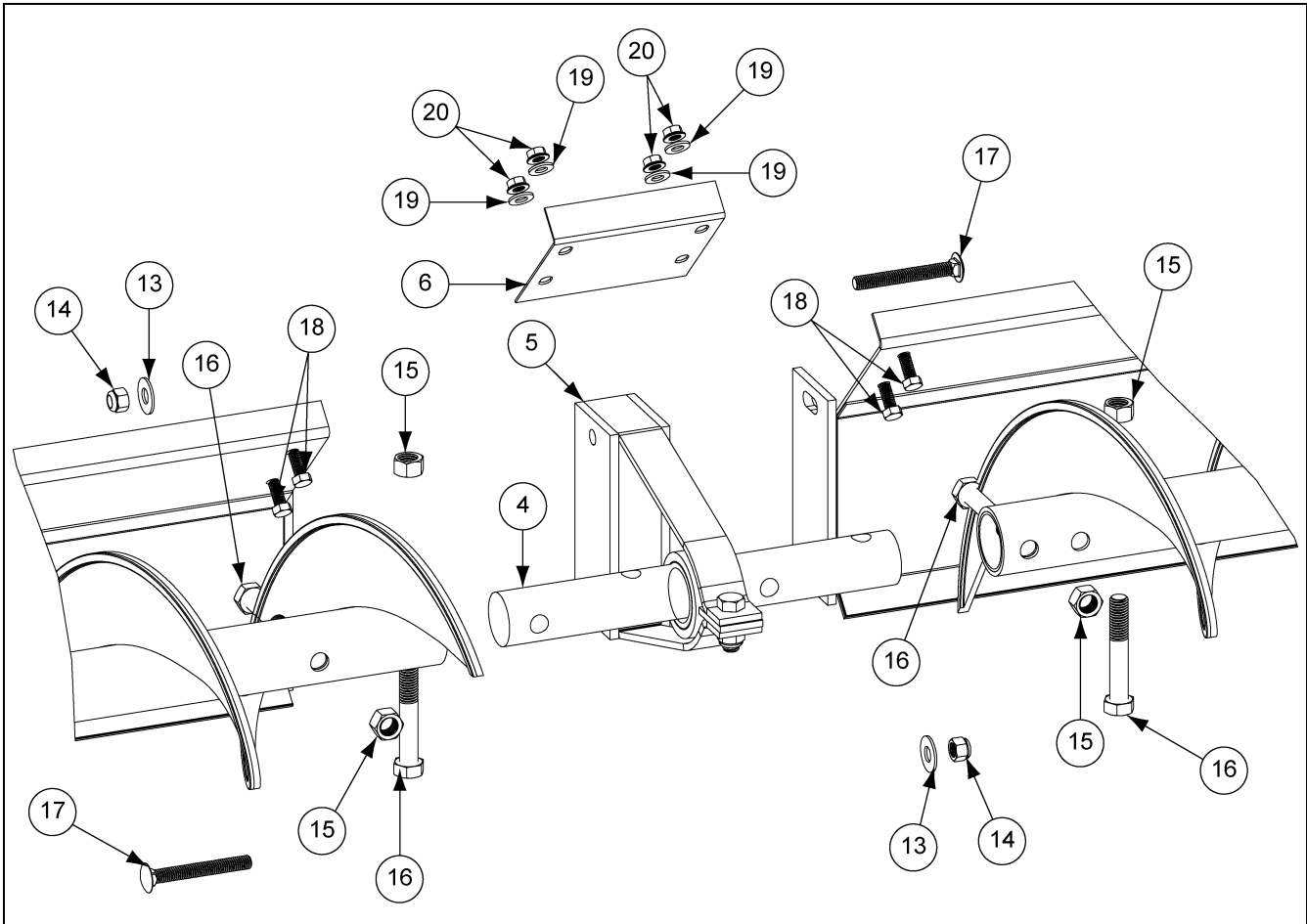
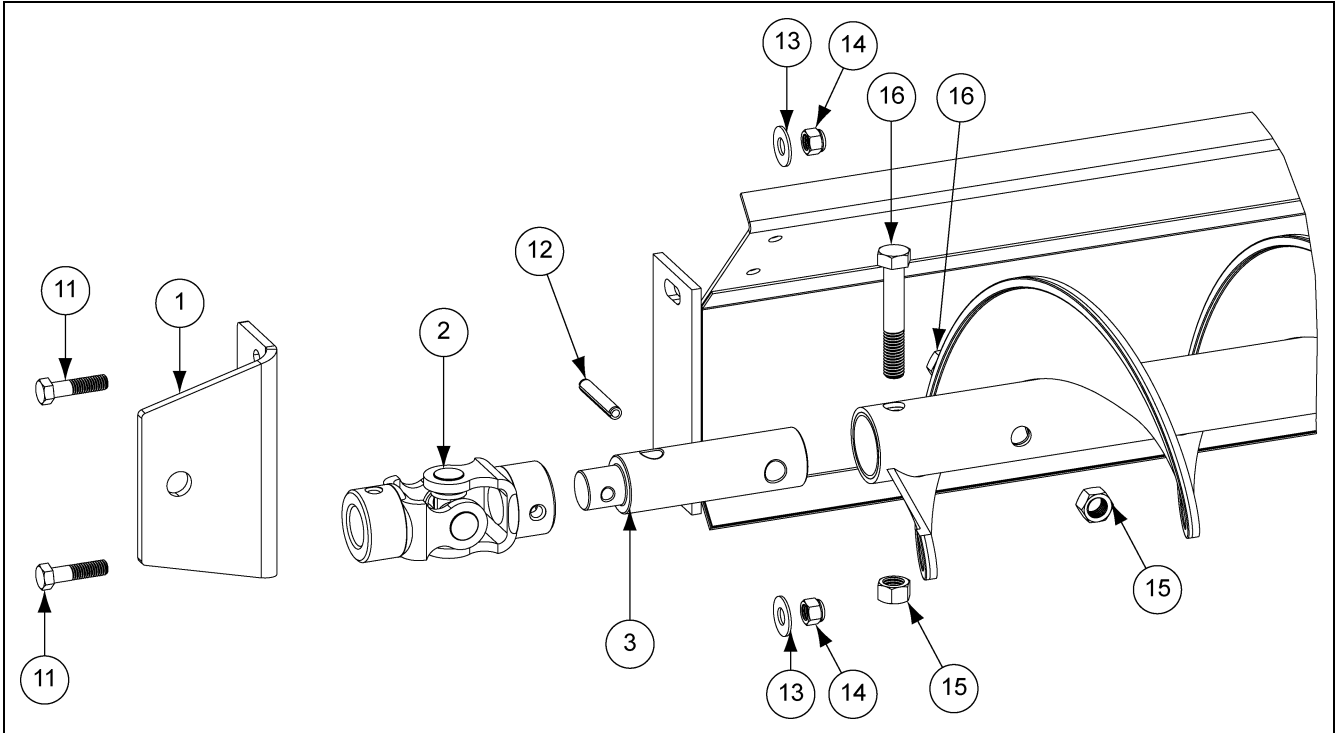

Assembled Sweep Arm Components (Continued)

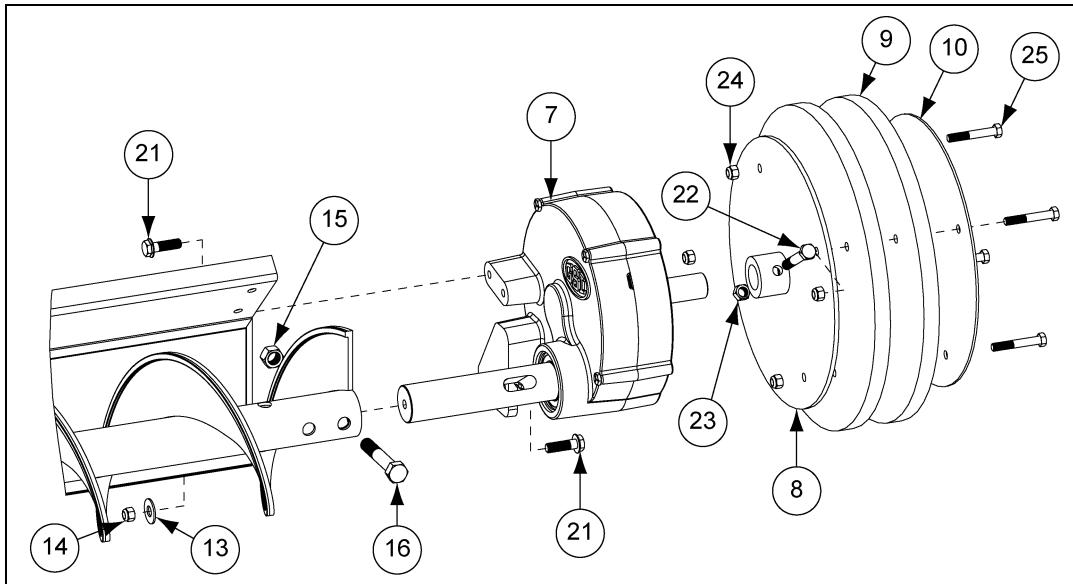

Assembled Sweep Arm Components Parts List

System	Ref #	Part #	Description
6"	1	GK6175	Shield Mounting Bracket
8" and 10"		GK4461	
ALL	2	GK1266	Universal Joint 1" Bore x 5" Long
6"	3	GK1678	Universal Joint Stub Shaft 1-1/4" x 5-3/4"
8" and 10"		GK5929	
6"	4	GK1736	Connecting Shaft 1-1/4" x 11-1/2"
8" and 10"		GK1951	
6"	5	GK2107	Bearing Stand Assembly
8" and 10"		GK1954	
ALL	6	GK5615	Shield Splice Plate
6"	7	GK80023	Reduction Wheel Drive, 7.889:1, Gear
8" and 10"		GK7960	
6"	8	GK80071	Wheel Hub Welded Assembly
8" and 10"		GK80072	
6"	9	GK4218	Wheel Disc, Rubber, 11"
8" and 10"		GK4241	
6"	10	GK4219	Outer Wheel Disc
8" and 10"		GK4240	
ALL	11	S-2086	3/8"-16 x 1-1/2" HHCS Bolt Zinc Grade 8
ALL	12	S-4377	5/16" x 2" Grooved Roll Pin
ALL	13	S-248	3/8" Flat Washer Zinc Grade 2
ALL	14	S-7383	3/8" Nylock Nut Zinc Grade 5
6"	15	S-8317	7/16"-14 Stover Nut Zinc Grade C
8" and 10"		S-8315	
6"	16	S-8316	7/16"-14 x 3" HHCS Bolt Zinc Grade 8
8" and 10"		S-8252	
ALL	17	S-8055	3/8"-16 x 3" Carriage Bolt Zinc Grade 5
ALL	18	S-4275	5/16"-18 x 3/4" HHTB Bolt Zinc Grade 5
ALL	19	S-1937	5/16" Flat Washer Zinc Grade 2
ALL	20	S-3611	5/16"-18 Serrated Flange Nut YDP Grade 2
ALL	21	S-9066	3/8"-16 x 1-1/4" Serrated Flange Bolt Zinc Grade 5
ALL	22	S-10107	3/8"-16 x 2-1/2" HHCS Bolt Zinc Grade 8
ALL	23	S-8251	3/8"-16 Stover Nut Grade C
ALL	24	S-7382	5/16"-18 Nylock Nut Zinc Grade 5
ALL	25	S-7329	5/16"-18 x 2" HHCS Bolt Zinc Grade 2

6", 8" and 10" Flight and Shield Bundle

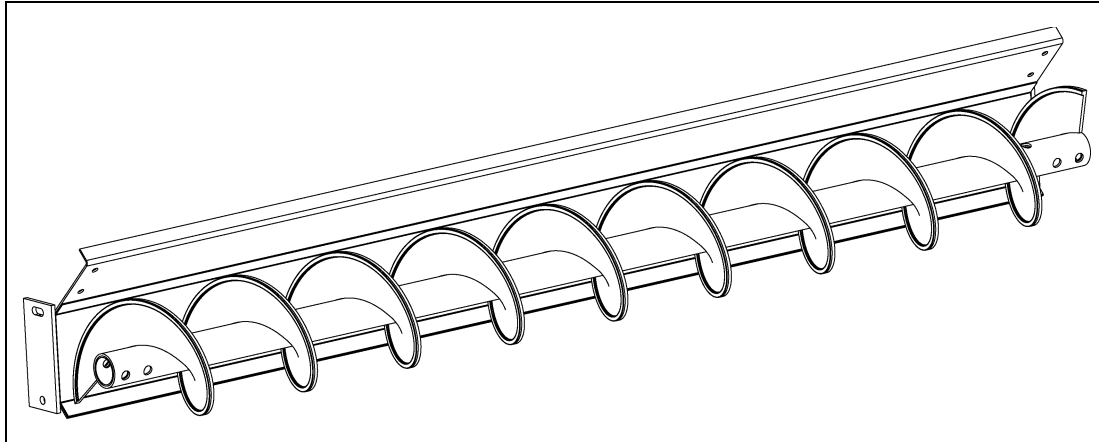

6" Flight and Shield Bundle Parts List

Bundle #	Part #	Description
GK6180	GK6178	6" x 4'-4" Flight Weldment
	GK5605	6" x 4'-4" Shield Assembly
GK6181	GK5932	6" x 5'-6" Flight Weldment
	GK5687	6" x 5'-6" Shield Assembly
GK5017	GK2134	6" x 5'-10" Flight Weldment
	GK4537	6" x 5'-10" Shield Assembly
GK6182	GK5933	6" x 7'-0" Flight Weldment
	GK5688	6" x 7'-0" Shield Assembly
GK6183	GK6179	6" x 7'-4" Flight Weldment
	GK5606	6" x 7'-4" Shield Assembly
GK6184	GK5934	6" x 8'-6" Flight Weldment
	GK5689	6" x 8'-6" Shield Assembly
GK5018	GK2129	6" x 8'-10" Flight Weldment
	GK4538	6" x 8'-10" Shield Assembly

8" and 10" Flight and Shield Bundle Parts List

Bundle #	Part #	Description
GK6185	GK5911	8"/10" x 4'-4" Flight Weldment
	GK5757	8"/10" x 4'-4" Shield Assembly
GK6186	GK5912	8"/10" x 5'-6" Flight Weldment
	GK5690	8"/10" x 5'-6" Shield Assembly
GK4827	GK2080	8"/10" x 5'-10" Flight Weldment
	GK4740	8"/10" x 5'-10" Shield Assembly
GK6187	GK5913	8"/10" x 7'-0" Flight Weldment
	GK5691	8"/10" x 7'-0" Shield Assembly
GK6188	GK5914	8"/10" x 7'-4" Flight Weldment
	GK5756	8"/10" x 7'-4" Shield Assembly
GK6189	GK5915	8"/10" x 8'-6" Flight Weldment
	GK5692	8"/10" x 8'-6" Shield Assembly
GK4828	GK2074	8"/10" x 8'-10" Flight Weldment
	GK4745	8"/10" x 8'-10" Shield Assembly

Spacer Plates for Reduction Drive Wheel

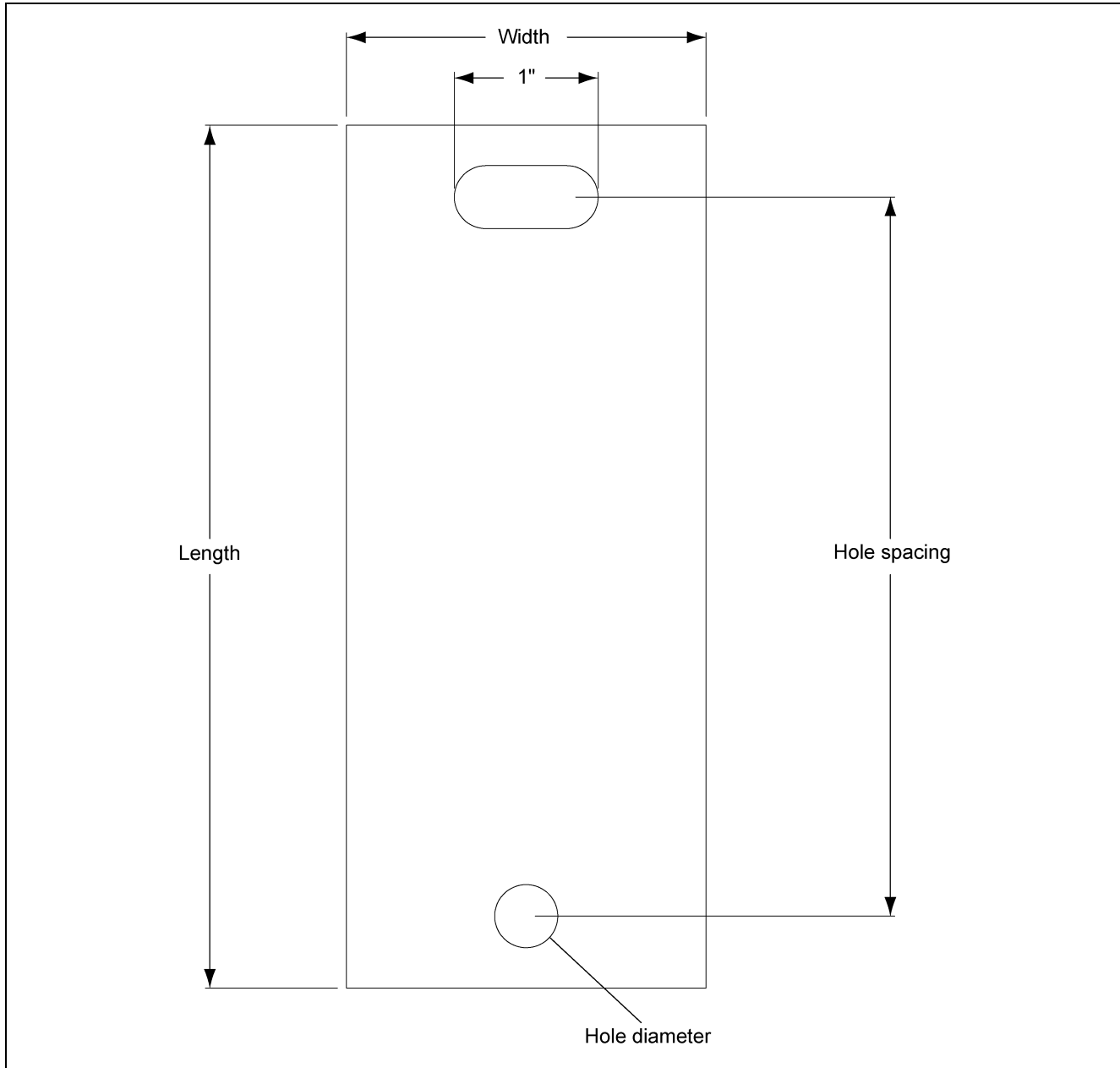

Spacer Plates for Reduction Drive Wheel Parts List

System	Part #	Thickness	Length	Width	Hole Diameter	Hole Spacing
6"	GK4209	14 Gauge	5"	2"	7/16"	4"
	GK4208	12 Gauge				
	GK4207	1/4"				
8" and 10"	GK4224	14 Gauge	6"	2-1/2"	7/16"	5"
	GK4225	12 Gauge				
	GK4226	1/4"				

Reduction Wheel Drive Components

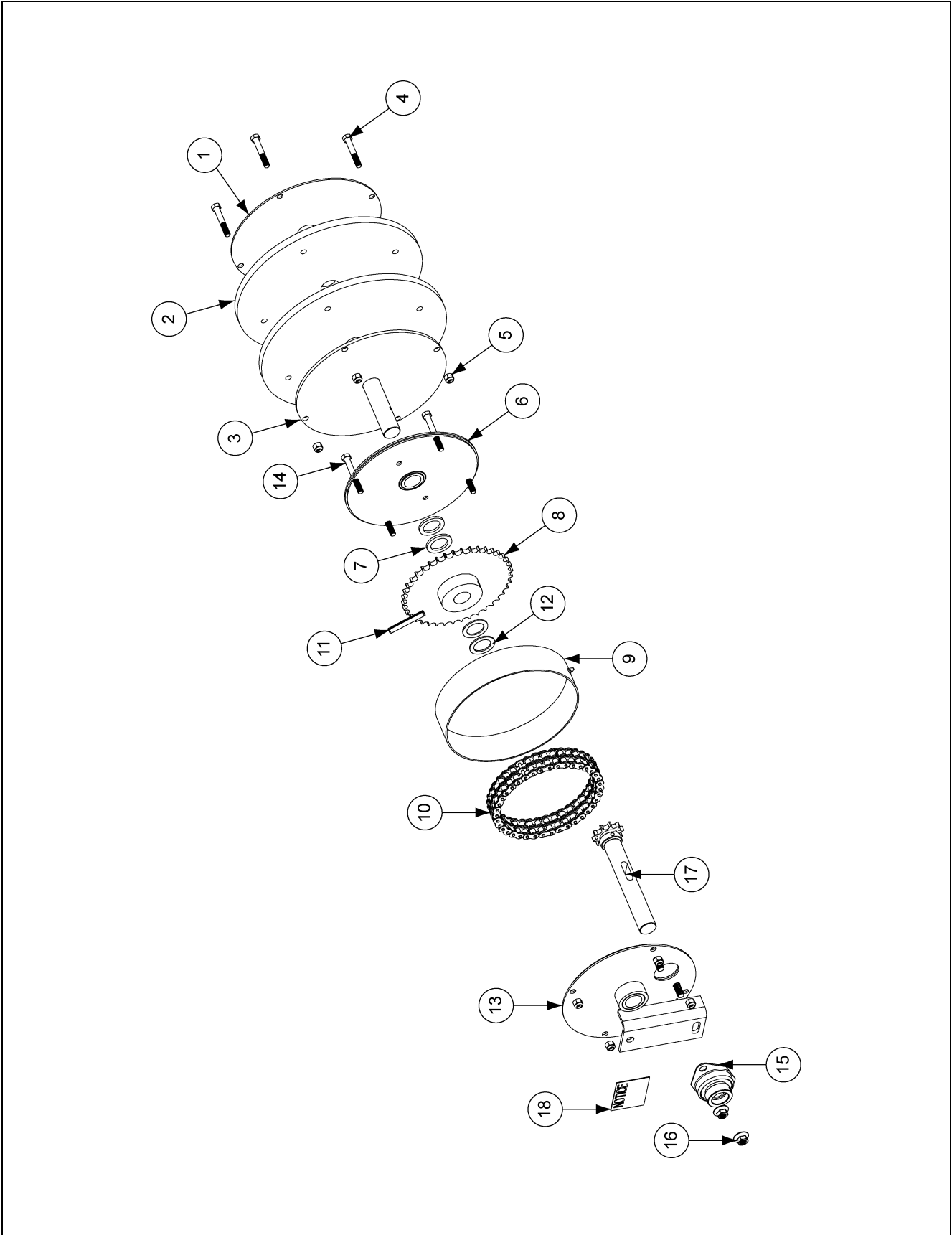

Reduction Wheel Drive Components Parts List

Ref #	Part #		Description
	GK5903	GK5904	
1	GK4219	GK4240	Outer Wheel Disk
2	GK4218	GK4241	Wheel Disk, Rubber
3	GK4217	GK4242	Inner Wheel Weldment
4	S-7329	S-7329	5/16"-18 x 2" HHCS Bolt Zinc Grade 2
5	S-7382	S-7382	5/16"-18 Nylock Nut Zinc Grade 5
6	GK4223	GK4223	Outer Drive Housing Weldment with Bushing
7	GK4211	GK4211	1" I.D. x 1-1/2" O.D. Flat Washer 10 Gauge Zinc
8	GK4234	GK4234	#40 40T Sprocket with Hub
9	GK4215	GK4215	Housing Ring with Grease Zerk
10	GK4233	GK4233	# 40 Double Roller Chain with Link
11	S-4383	S-4383	5/16" x 2-1/4" Rolled Spring Pin
12	GK4210	GK4210	1" I.D. x 1-1/2" O.D. Flat Washer 14 Gauge Zinc
13	GK4213	GK4228	Inner Drive Housing Weldment with Bushing
14	S-7076	S-7076	5/16"-18 x 2-1/2" HHCS Bolt Zinc Grade 5
15	GK4232	GK4233	Bearing, 1" I.D., 2 Hole Flange
16	S-968	S-968	3/8"-16 Serrated Flange Nut Zinc Grade 5
17	GK6526	GK6526	Drive Shaft, with Sprocket and Roll Pin
18	DC-1687	DC-1687	Shipped without Grease Decal

Reduction Wheel Drive Additions Components Parts List

System	Part #	Description
Complete Drive		
6"	GK5903	Reduction Wheel Drive, 4:1, Chain
8" and 10"	GK5904	Reduction Wheel Drive, 4:1, Chain
Bushing for Drives		
6"	GK4205	Bushing 1" x 1" x 4-3/8"
8" and 10"	GK4206	Bushing 1-1/2" x 1" x 4-3/8"
Hardware for Flight, Bushing and Drive Shaft		
6"	S-6762	3/8"-16 x 2-1/2" HHCS Bolt Zinc Grade 5
8" and 10"	S-8677	3/8"-16 x 3" HHCS Bolt YDP Grade 8
ALL	S-8251	3/8"-16 Stover Nut Grade C
Hardware for Shield and Drive Housing		
6"	S-3727	3/8"-16 x 1-3/4" HHCS Bolt YDP Grade 8
8" and 10"	S-8706	3/8"-16 x 1-3/4" HHTB Bolt Zinc Grade 5
ALL	S-248	3/8" Flat Washer Zinc Grade 2
ALL	S-7383	3/8" Nylock Nut Zinc Grade 5

10. Troubleshooting

Problem	Possible Cause	Solution
The auger is vibrating.	The drive belt may be too tight, binding the head stub and flight. Damage can occur to the auger flighting, causing noise. Damage usually is caused from foreign material being run through the auger.	Adjust the drive belt to the proper tightness.
		It may be necessary to remove the flighting for inspection.
Capacity is too low.	There may not be enough grain reaching the auger.	Make sure the intake has not bridged over, restricting flow. The flighting at the intake should be covered with grain for maximum capacity.
	The auger is moving too slowly.	Check the auger speed. Low capacity will result from speeds slower than recommended.
The auger plugs.	The auger may be "jamming" because too much grain is reaching the auger.	Decrease the amount of grain the auger is gathering.
	The motor may be too small or wired improperly.	If the motor is a newer light weight aluminum type, the next larger size may be desirable.
	The grain may be wet.	If wet grain or other hard-to-move material is being augered, use a larger size motor than recommended for normal use.
	The auger may be jammed with foreign material.	Remove any foreign material in the auger.
	The discharge end may be plugged.	Unplug any plugs at the discharge end of the auger.
The sweep flight and shield are no longer moving.	Too much drag.	Check the clearance between the shield and the bin floor. Make sure there is room for the auger to move. Adjusting the shield may be necessary.
	Worn sweep wheel.	The sweep wheel wears down over time. Replace the wheel.
	Unconditioned grain.	Moisture and/or insects can cause the grain to harden or "Cake-up". Disconnect and lock out the power to the auger before going into the bin to correct this problem or to address any other problem.

GSI Group, LLC Limited Warranty

The GSI Group, LLC ("GSI") warrants products which it manufactures to be free of defects in materials and workmanship under normal usage and conditions for a period of 12 months after sale to the original end-user or if a foreign sale, 14 months from arrival at port of discharge, whichever is earlier. The end-user's sole remedy (and GSI's only obligation) is to repair or replace, at GSI's option and expense, products that in GSI's judgment, contain a material defect in materials or workmanship. Expenses incurred by or on behalf of the end-user without prior written authorization from the GSI Warranty Group shall be the sole responsibility of the end-user.

Warranty Extensions:

The Limited Warranty period is extended for the following products:

	Product	Warranty Period	
AP Fans and Flooring	Performer Series Direct Drive Fan Motor	3 Years	* Warranty prorated from list price: 0 to 3 years - no cost to end-user 3 to 5 years - end-user pays 25% 5 to 7 years - end-user pays 50% 7 to 10 years - end-user pays 75%
	All Fiberglass Housings	Lifetime	
	All Fiberglass Propellers	Lifetime	
Cumberland Feeding/Watering Systems	Feeder System Pan Assemblies	5 Years **	** Warranty prorated from list price: 0 to 3 years - no cost to end-user 3 to 5 years - end-user pays 50%
	Feed Tubes (1-3/4" and 2.00")	10 Years *	
	Centerless Augers	10 Years *	
	Watering Nipples	10 Years *	
Grain Systems	Grain Bin Structural Design	5 Years	
Grain Systems Farm Fans Zimmerman	Portable and Tower Dryers	2 Years	† Motors, burner components and moving parts not included. Portable dryer screens included. Tower dryer screens not included.
	Portable and Tower Dryer Frames and Internal Infrastructure †	5 Years	

GSI further warrants that the portable and tower dryer frame and basket, excluding all auger and auger drive components, shall be free from defects in materials for a period of time beginning on the twelfth (12th) month from the date of purchase and continuing until the sixtieth (60th) month from the date of purchase (extended warranty period). During the extended warranty period, GSI will replace the frame or basket components that prove to be defective under normal conditions of use without charge, excluding the labor, transportation, and/or shipping costs incurred in the performance of this extended warranty.

Conditions and Limitations:

THERE ARE NO WARRANTIES THAT EXTEND BEYOND THE LIMITED WARRANTY DESCRIPTION SET FORTH ABOVE. SPECIFICALLY, GSI MAKES NO FURTHER WARRANTY OF ANY KIND, EXPRESS OR IMPLIED, INCLUDING, WITHOUT LIMITATION, WARRANTIES OF MERCHANTABILITY OR FITNESS FOR A PARTICULAR PURPOSE OR USE IN CONNECTION WITH: (I) PRODUCT MANUFACTURED OR SOLD BY GSI OR (II) ANY ADVICE, INSTRUCTION, RECOMMENDATION OR SUGGESTION PROVIDED BY AN AGENT, REPRESENTATIVE OR EMPLOYEE OF GSI REGARDING OR RELATED TO THE CONFIGURATION, INSTALLATION, LAYOUT, SUITABILITY FOR A PARTICULAR PURPOSE, OR DESIGN OF SUCH PRODUCTS.

GSI shall not be liable for any direct, indirect, incidental or consequential damages, including, without limitation, loss of anticipated profits or benefits. The sole and exclusive remedy is set forth in the Limited Warranty, which shall not exceed the amount paid for the product purchased. This warranty is not transferable and applies only to the original end-user. GSI shall have no obligation or responsibility for any representations or warranties made by or on behalf of any dealer, agent or distributor.

GSI assumes no responsibility for claims resulting from construction defects or unauthorized modifications to products which it manufactured. Modifications to products not specifically delineated in the manual accompanying the equipment at initial sale will void the Limited Warranty.

This Limited Warranty shall not extend to products or parts which have been damaged by negligent use, misuse, alteration, accident or which have been improperly/inadequately maintained. This Limited Warranty extends solely to products manufactured by GSI.

Prior to installation, the end-user has the responsibility to comply with federal, state and local codes which apply to the location and installation of products manufactured or sold by GSI.

This equipment shall be installed in accordance with the current installation codes and applicable regulations, which should be carefully followed in all cases. Authorities having jurisdiction should be consulted before installations are made.

G S I G R O U P



GSI Group
1004 E. Illinois St.
Assumption, IL 62510-0020
Phone: 1-217-226-4421
Fax: 1-217-226-4420
www.gsiag.com



GSI is a worldwide brand of AGCO Corporation.