

6", 8" and 10" Utility and Bulk Tank Auger

Assembly and Operation Manual

PNEG-1435

Version: 2.0

Date: 12-23-15



This manual is valid for the Bulk Tank and Utility Auger catalog numbers in the tables below:

Auger Length	6" Utility Auger	8" Utility Auger	10" Utility Auger
11'	GUF6111A GUF6112B1A	GUF8111A -	GUF10111A -
16'	GUF6161A GUF6162B1A	GUF8161A -	GUF10161A -
21'	GUF6211A GUF6212B1A	GUF8211A -	GUF10211A -
27'	GUF6271A GUF6272B1A	GUF8271A -	- -
31'	-	-	GUF10311A
33'	GUF6331A GUF6332B1A	GUF8331A -	- -
41'	GUF6411A GUF6412B1A	GUF8411A -	GUF10411A -
53'	-	GUF8531A	-

Auger Length	6" Bulk Tank Auger	8" Bulk Tank Auger
11'	GBF6111A GBF6112B1A	GBF8111A -
16'	GBF6161A GBF6162B1A	GBF8161A -
21'	GBF6211A GBF6212B1A	GBF8211A -
27'	GBF6271A GBF6272B1A	GBF8271A -
33'	GBF6331A GBF6332B1A	GBF8331A -
41'	GBF6411A GBF6412B1A	GBF8411A -

NOTICE: This equipment shall be installed in accordance with the current installation codes and applicable regulations which should be carefully followed in all cases. Authorities having jurisdiction should be consulted before installation occurs.

Contents

Chapter 1 Introduction	4
General Information	4
Receiving Merchandise and Filing Claims	4
Capacity	4
Chapter 2 Safety	5
Safety Guidelines	5
Cautionary Symbols Definitions	6
Safety Cautions	7
Safety Sign-Off Sheet	10
Chapter 3 Safety Decals	11
Chapter 4 Assembly and Installation	14
Assembling the Flight Extension	14
Install the Truss Support	19
Installing the Intake Guard	20
Installing Drive Shaft	24
Mounting Bearing to Bearing Plate	25
Installing Bearing Plate onto Tube	26
Installing the Motor Mount Adjuster	27
Installing the Motor Mount Plate	28
Installing the Belt Guard Brackets	30
Installing the Lock Collar	31
Installing the Pulley	32
Tightening the Lock Collar	33
Installing the Motor (Not Provided)	33
Installing the Belts	34
Installing the Belt Guard	34
Chapter 5 Electric Drive Motors	35
Horsepower Information for Electric Motors	35
Power Source	36
Chapter 6 Start-Up	37
Start-Up and Break-In	37
Chapter 7 Shut Down	38
Normal Shut Down	38
Emergency Shut Down	38
Lock Out	38
Storage Preparation	38
Chapter 8 Operation/Maintenance	39
Operate the Auger	39
Maintain the Auger	39
Chapter 9 Parts List	41
6" Utility and Bulk Auger Parts	42
8" Utility and Bulk Auger Parts	44
10" Utility and Bulk Auger Parts	46
Chapter 10 Troubleshooting	48
Chapter 11 Warranty	49

1. Introduction

General Information

READ THIS MANUAL carefully to learn how to properly use and install equipment. Failure to do so could result in personal injury or equipment damage.

INSPECT the shipment immediately upon arrival. The customer is responsible for ensuring that all quantities are correct. The customer should report and note any damage or shortage on the bill of lading to justify their claim to the transport company.

THIS MANUAL SHOULD BE CONSIDERED a permanent part of your equipment and should be easily accessible when needed.

This warranty provides you the assurance that the company will back its products when defects appear within the warranty period. In some circumstances, the company also provides field improvements, often without charge to the customer, even if the product is out of warranty. Should the equipment be abused, or modified to change its performance beyond the factory specifications, the warranty will become void and field improvements may be denied.

Receiving Merchandise and Filing Claims

INSPECT the shipment immediately upon arrival. The Customer is responsible for ensuring that all quantities are correct. Report any damage or shortages by recording a detailed description on the Bill of Lading to justify the Customer's claim from the Transport Firm. When receiving merchandise, it is important to check both the quantity of parts and their descriptions with the packing list enclosed within each package. All claims for freight damage or shortage must be made by the consignee within ten (10) days from the date of the occurrence of freight damage. The consignee should accept the shipment after noting the damage or loss.

Capacity

A. The capacities may vary greatly under varying conditions. The following factors play a role in the performance of the auger:

- Speed
- Angle of operation
- Moisture content
- Amounts of foreign matter
- Different materials
- Methods of feeding

B. For example, a twenty-five percent (25%) moisture could cut capacity by as much as 40% under some conditions.

Safety Guidelines

Safety guidelines are general-to-specific safety rules that must be followed at all times. This manual is written to help you understand safe operating procedures and problems that can be encountered by the operator and other personnel when using this equipment. Save these safety guidelines for future reference.

As owner or operator, you are responsible for understanding the requirements, hazards, and precautions that exist and to inform others as required. Unqualified persons must stay out of the work area at all times.

Alterations must not be made to the equipment. Alterations can produce dangerous situations resulting in **SERIOUS INJURY** or **DEATH**.

This equipment must be installed in accordance with the current installation codes and applicable regulations, which must be carefully followed in all cases. Authorities having jurisdiction must be consulted before installations are made.

When necessary, you must consider the installation location relative to electrical, fuel and water utilities.

Personnel operating or working around equipment must read this manual. This manual must be delivered with equipment to its owner. Failure to read this manual and its safety instructions is a misuse of the equipment.

ST-0001-2

Cautionary Symbols Definitions

Cautionary symbols appear in this manual and on product decals. The symbols alert the user of potential safety hazards, prohibited activities and mandatory actions. To help you recognize this information, we use the symbols that are defined below.



This symbol indicates an imminently hazardous situation which, if not avoided, **will result in serious injury or death.**



This symbol indicates a potentially hazardous situation which, if not avoided, **can result in serious injury or death.**



This symbol indicates a potentially hazardous situation which, if not avoided, **can result in minor or moderate injury.**



This symbol is used to address practices not related to personal injury.



This symbol indicates a general hazard.



This symbol indicates a prohibited activity.

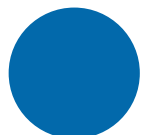

This symbol indicates a mandatory action.

ST-0005-2

Safety Cautions

Use Personal Protective Equipment

- Use appropriate personal protective equipment:

Eye Protection



Respiratory Protection



Foot Protection



Hearing Protection



Head Protection



Fall Protection



Hand Protection



- Wear clothing appropriate to the job.
- Remove all jewelry.
- Tie long hair up and back.

ST-0004-1

Follow Safety Instructions

- Carefully read all safety messages in this manual and safety signs on your machine. Keep signs in good condition. Replace missing or damaged safety signs. Be sure new equipment components and repair parts include the current safety signs. Replacement safety signs are available from the manufacturer.
- Learn how to operate the machine and how to use controls properly. Do not let anyone operate without instruction.
- If you do not understand any part of this manual or need assistance, contact your dealer.



ST-0002-1

2. Safety

Maintain Equipment and Work Area

- Understand service procedures before doing work. Keep area clean and dry.
- Never service equipment while it is operating. Keep hands, feet, and clothing away from moving parts
- Keep your equipment in proper working condition. Replace worn or broken parts immediately.



ST-0003-1

Operate Motor Properly

- All electrical connections must be made in accordance with the National Electric Code (US) or Canadian Electrical Code (CEC). Be sure equipment and bins are properly grounded.
- Lock-out power before resetting motor overloads.
- Do not repetitively stop and start the drive in order to free a plugged condition. Jogging the drive in this manner can damage the equipment and drive components.



ST-0009-2

Rotating Auger Hazard

- Keep clear of rotating augers and moving parts.
- Do not remove or modify guards or covers.
- Lock-out power source before making adjustments, cleaning, or maintaining equipment.
- Failure to follow these precautions will result in serious injury or death.



ST-0037-1

Stay Clear of Hoisted Equipment

- Always use proper lifting or hoisting equipment when assembling or disassembling equipment.
- Do not walk or stand under hoisted equipment.
- Always use sturdy and stable supports when needed for installation. Not following these safety precautions creates the risk of falling equipment, which could crush personnel and cause serious injury or death.



ST-0047-1

Stay Clear of Rotating Parts

- Do not enter the bin while the equipment is in operation.
- Entanglement in rotating augers will cause serious injury or death.
- Keep all shields and covers in place at all times.
- Lock-out power source before making adjustments, cleaning, or maintaining equipment.



ST-0008-1

Use Unload Equipment Properly

- Do not operate this equipment alone. Make sure someone nearby is aware of the proper shut down sequence in the event of an emergency.
- Do not allow any person intoxicated or under the influence of drugs to operate this equipment. All operators must be adequately rested and prepared to perform all functions of operating the equipment.
- Do not start equipment until all persons are clear of the work area and safety guards are in place.
- Do not allow anyone inside a bin, truck, or wagon which is being unloaded by an auger. Flowing grain can trap and suffocate in seconds.
- Use ample overhead lighting after sunset to light the work area.
- Always use caution to not hit the auger when positioning the load.
- Do not leave equipment operating while unattended.
- Be aware of pinch points, which can trap or catch objects and cause injury.
- Be sure all equipment is locked in position before operating.
- Always lock out all power sources to the equipment when unloading is finished.



ST-0051-1

The decal list below has all the safety decals that should be included with the equipment. The following [Pages 11-13](#) show what the decals look like and where they should be located on the equipment. Inspect all decals and replace any that are illegible, worn, or missing. Contact your local dealer or the manufacturer to order replacement decals free of charge.

Contact:

GSI Decals
 1004 E. Illinois St.
 Assumption, IL. 62510
 Phone: 217-226-4421

6", 8" and 10" Roof Auger Decal List			
Ref #	Part #	Description	Size
1	DC-1381	Danger - Shear Point	4-1/2" x 2"
2	DC-994	Danger - Shear Point	4-1/2" x 2"
3	DC-834	Danger - Unloading	9" x 3-3/4"
4	DC-1379	Notice - 1-11	5-1/8" x 7-3/8"
5	DC-455	Danger - Rotating Flight	4" x 5-3/4"
6	DC-1234	Caution	2-1/4" x 2-3/4"
7	DC-1395	Danger - Rotating Flight	4-1/4" x 6-1/4"

The diagram shows two types of roof augers: a **Bulk auger** and a **Utility auger**. Callouts point to specific safety decal locations:

- DC-834:** A yellow triangular warning decal with a black border and a black silhouette of a hand being caught in a rotating auger. Below the decal is the text: "Rotating flighting can kill or dismember." To the right of the decal is a red header with a white exclamation mark icon and the word "DANGER" in white. Below the header is a list of five safety instructions:
 1. Keep all safety shields and devices in place.
 2. Keep hands, feet, hair, loose clothing, and other objects away from moving parts.
 3. Do not operate the machine unless visitors, children, and all other untrained personnel are well clear of the machine and work area.
 4. Stop the machine and lock out power to clean, lubricate, service, or adjust.
 5. Read operation and assembly manual completely before using equipment.
 At the bottom right of this section is the text: "Failure to heed these warnings will result in serious injury or death." and the part number "DC-834".
- DC-455:** A yellow triangular warning decal with a black border and a black silhouette of a hand being caught in a rotating auger. To the right of the decal is a red header with a white exclamation mark icon and the word "DANGER" in white. Below the header is the text: "Keep clear of rotating auger and moving parts. Do not remove or modify guards. Disconnect and lockout power before servicing. Failure to do so will result in serious injury or death." At the bottom right of this section is the text: "Failure to do so will result in serious injury or death." and the part number "DC-455".

3. Safety Decals

Check components shown below to ensure that the safety decals are in place and in good condition. If a decal cannot be easily read for any reason or has been painted over, replace it immediately. Contact your dealer or the manufacturer to order a replacement decal free of charge.

Contact:

GSI Decals
 1004 E. Illinois St.
 Assumption, IL. 62510
 Phone: 217-226-4421

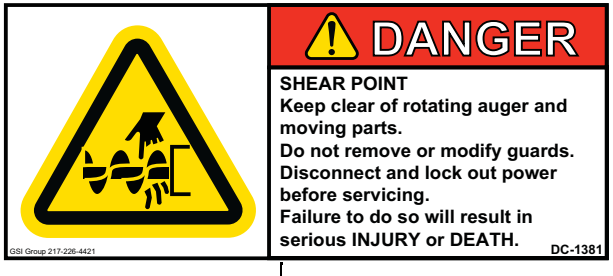

2 DC-994

1 DC-1381

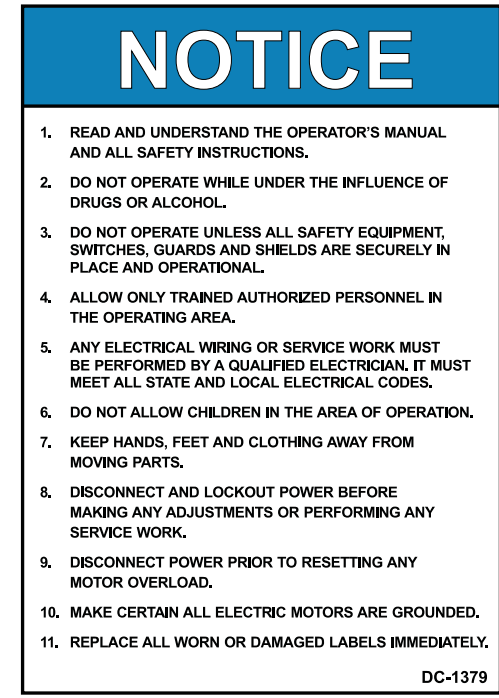

4 DC-1379

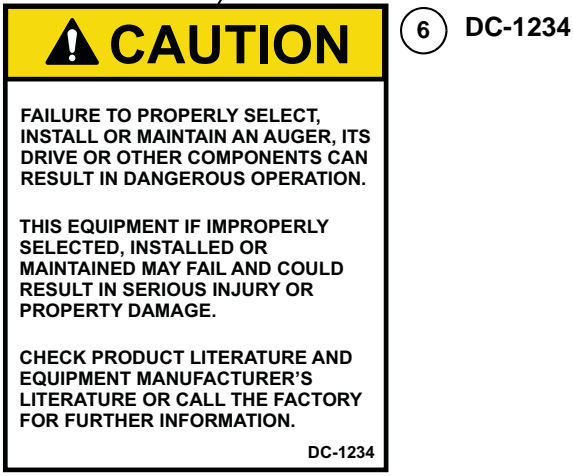
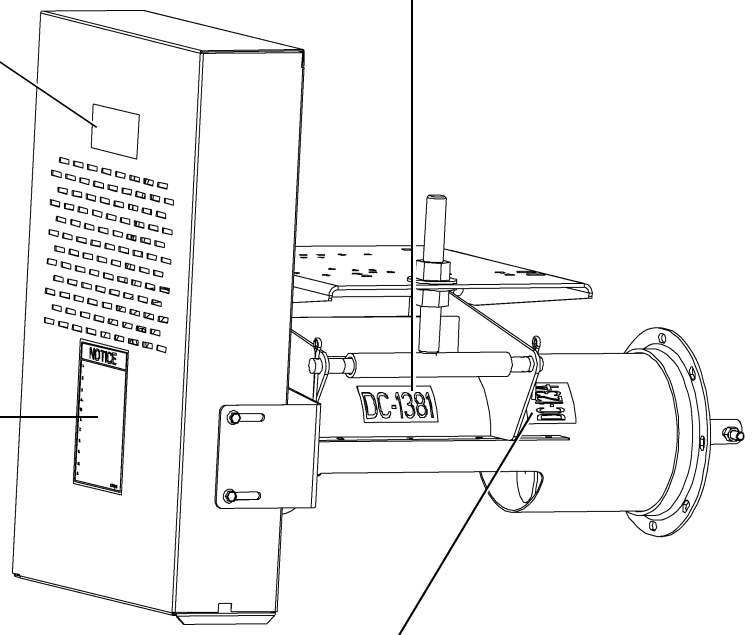

6 DC-1234

- A. DANGER Sign No. DC-1395 was supplied with your bin unloading equipment. This safety sign should be applied to the side of the bin near the bin opening, so it will be viewed by people entering into the bin storage building. Do not cover any safety signs or any other signs that are already there.
- B. If the safety sign location suggested is not in full view because of equipment modifications, other equipment in the area or any reason, then locate the safety sign in a more suitable location.
- C. Be certain the surface is clean, dry and free of dirt and oil. Peel paper backing from decals and stick into place. The adhesive backing will bond on contact.

NOTE: *Please remember, safety signs provide important safety information for people working near bin unloading equipment that is in operation.*

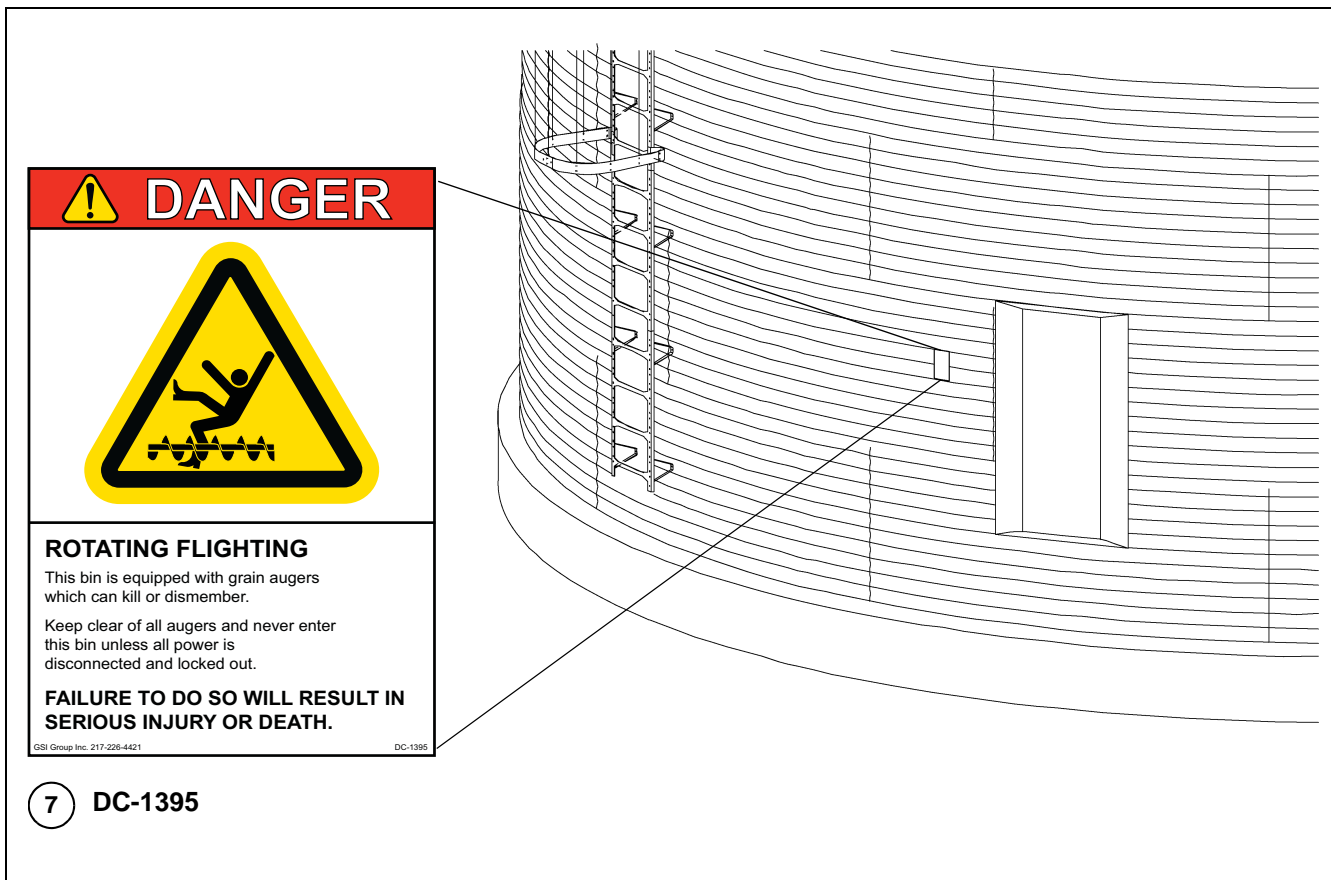

NOTE: *If the Safety Sign cannot be easily read for any reason or has been painted over, replace it immediately. Additional Safety Signs may be obtained free of charge from your dealer, distributor or ordered from the factory.*

Order SAFETY SIGN NO. DC-1395

4. Assembly and Installation

Assembling the Flight Extension

NOTE: If the auger does not include an extension skip ahead to [Step 5 on Page 18](#).

1. Begin by sliding the extension connecting band (A) onto the main auger tube (B). (See [Figure 4A](#).)

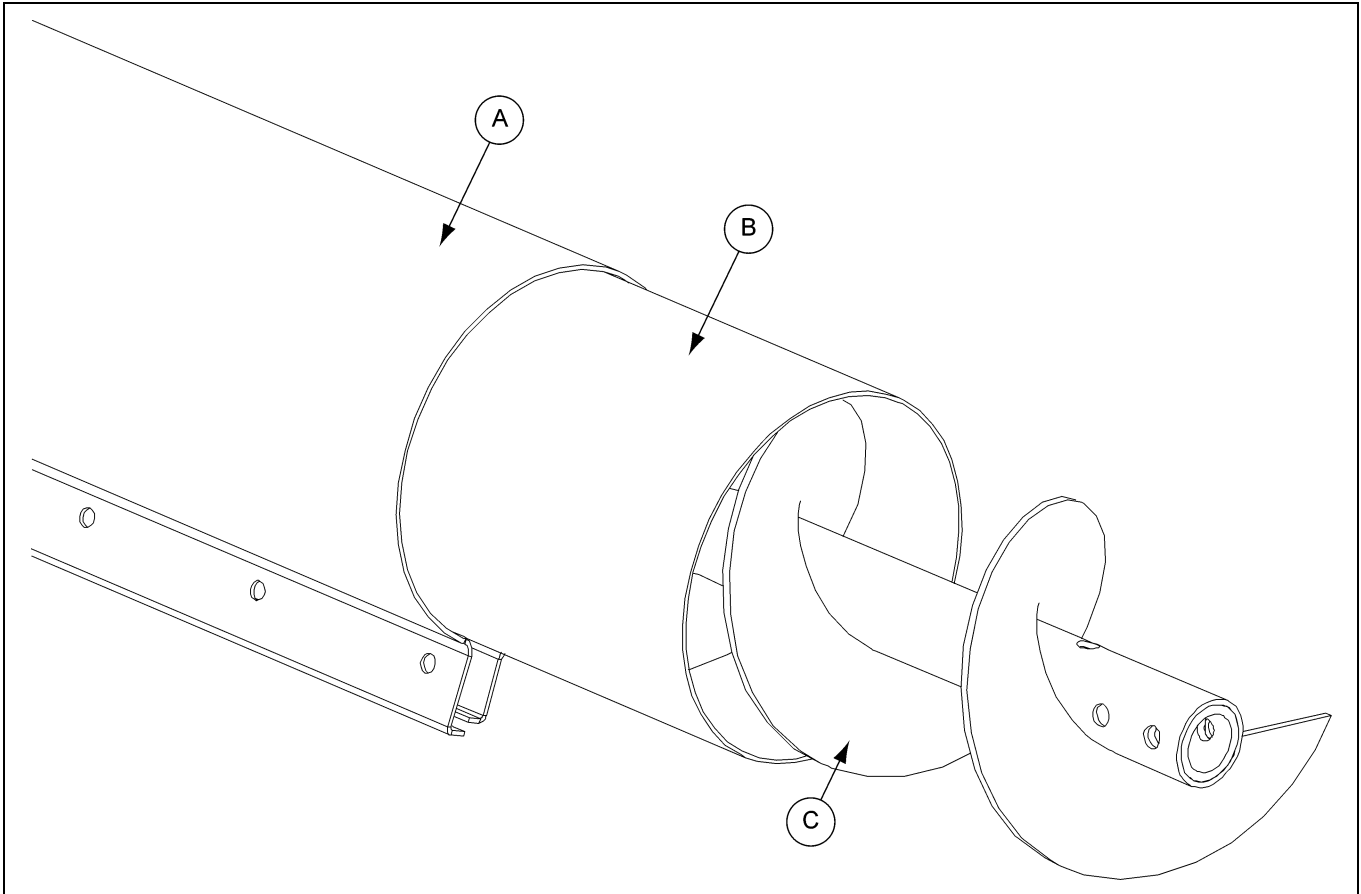

Figure 4A

Ref #	Description
A	Extention Connecting Band
B	Main Auger Tube
C	Main Flight

4. Assembly and Installation

2. Slide the flight connecting shaft (F) into the main section of flight (C) and bolt (D) together with grade 8 hex bolt (D) and stover nut (E). Next slide extension flight (G) onto connecting shaft (F) and bolt (D) together using proper grade 8 bolts (D) and stover nuts (E). (*See Chart* and *See Figure 4B.*)

Flight Hardware	
6"	3/8"-16 x 2" Grade 8 Hex Bolts
8"	7/16"-14 x 3" Grade 8 Hex Bolts
10"	1/2"-13 x 3-1/2" Grade 8 Hex Bolts

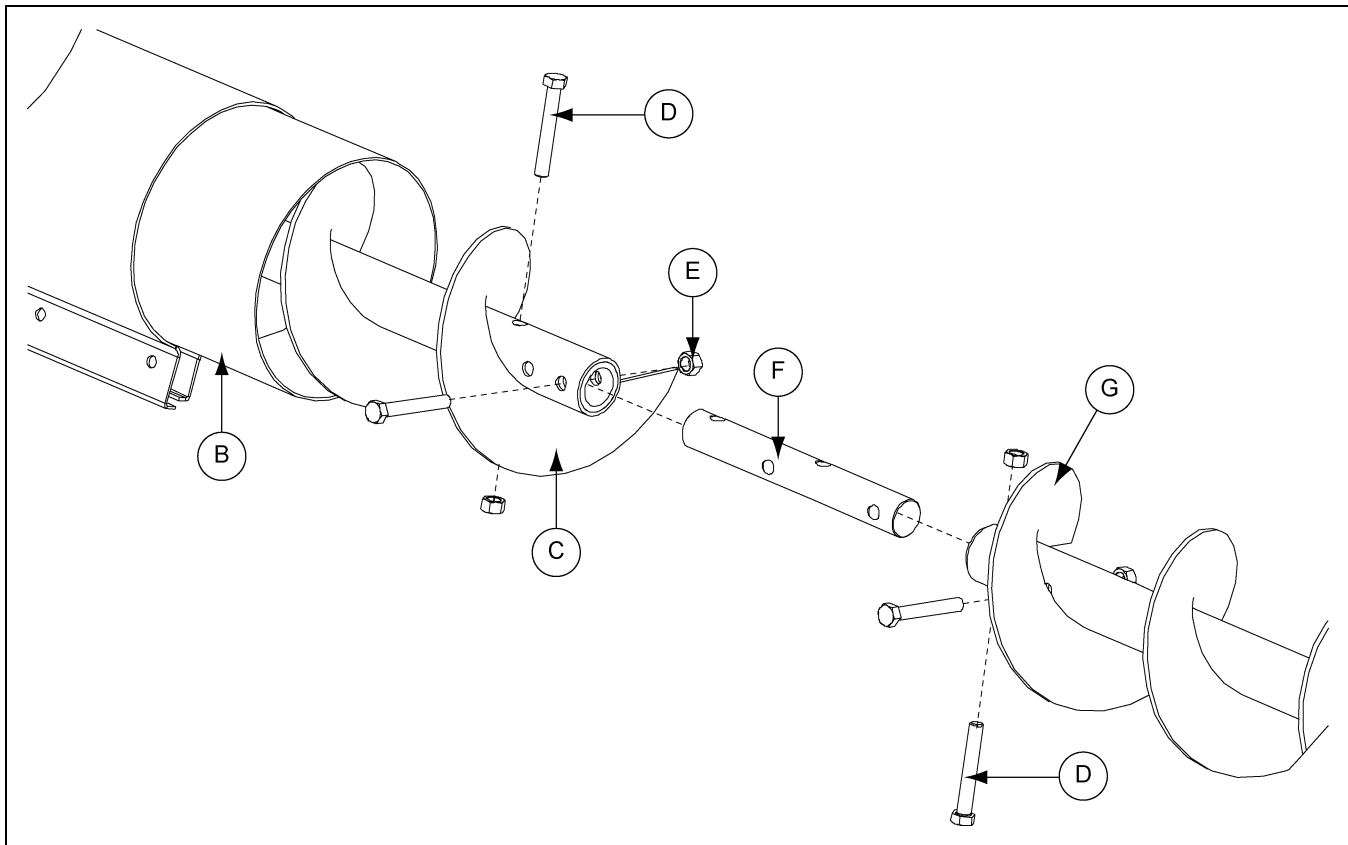

Figure 4B

Ref #	Description
B	Main Auger Tube
C	Main Flight
D	Bolt (<i>See Chart</i>)
E	Stover Nut
F	Flight Connecting Shaft
G	Extension Flight

4. Assembly and Installation

3. Slide the extension tube (H) over the extension flight (G), making sure the tube (H) is pressed securely against the main auger tube (B). (See Figure 4C.)

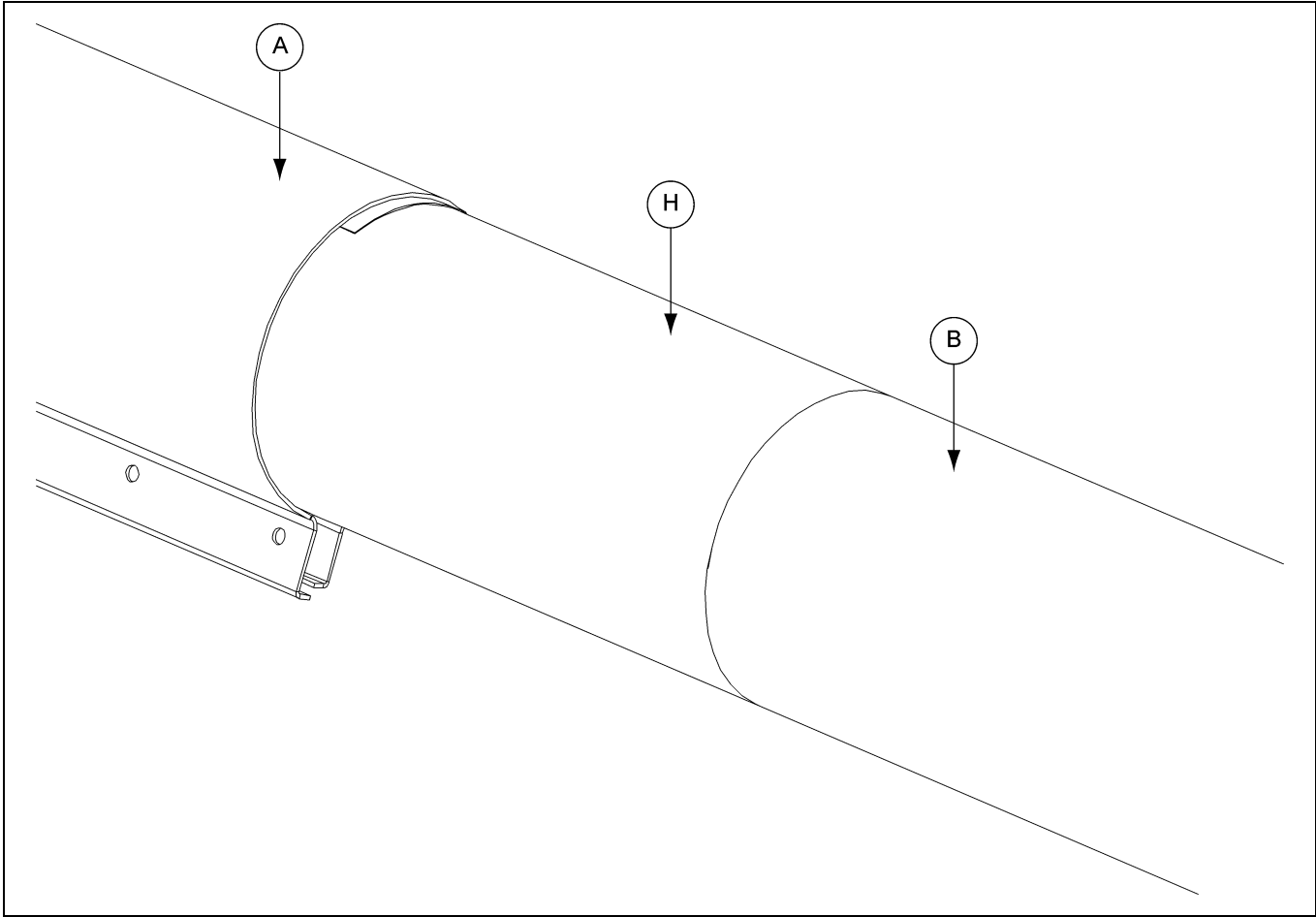

Figure 4C

Ref #	Description
A	Extension Connecting Band
B	Main Auger Tube
H	Extension Tube

4. Assembly and Installation

4. Slide the extension connecting band (A) over the two (2) sections of tube (H), making sure the connecting band (A) is centered over the mated surfaces of the tubes (H). Tighten the connecting band (A) down using the correct hex bolts (D) and nylock nuts (I). (*See Chart* and *See Figure 4D.*)

Connecting Band Bolts	
6"	5/16"-18 Grade 5 Nylock Nut
8"	5/16"-18 Grade 5 Nylock Nut
10"	3/8"-16 Grade 5 Nylock Nut

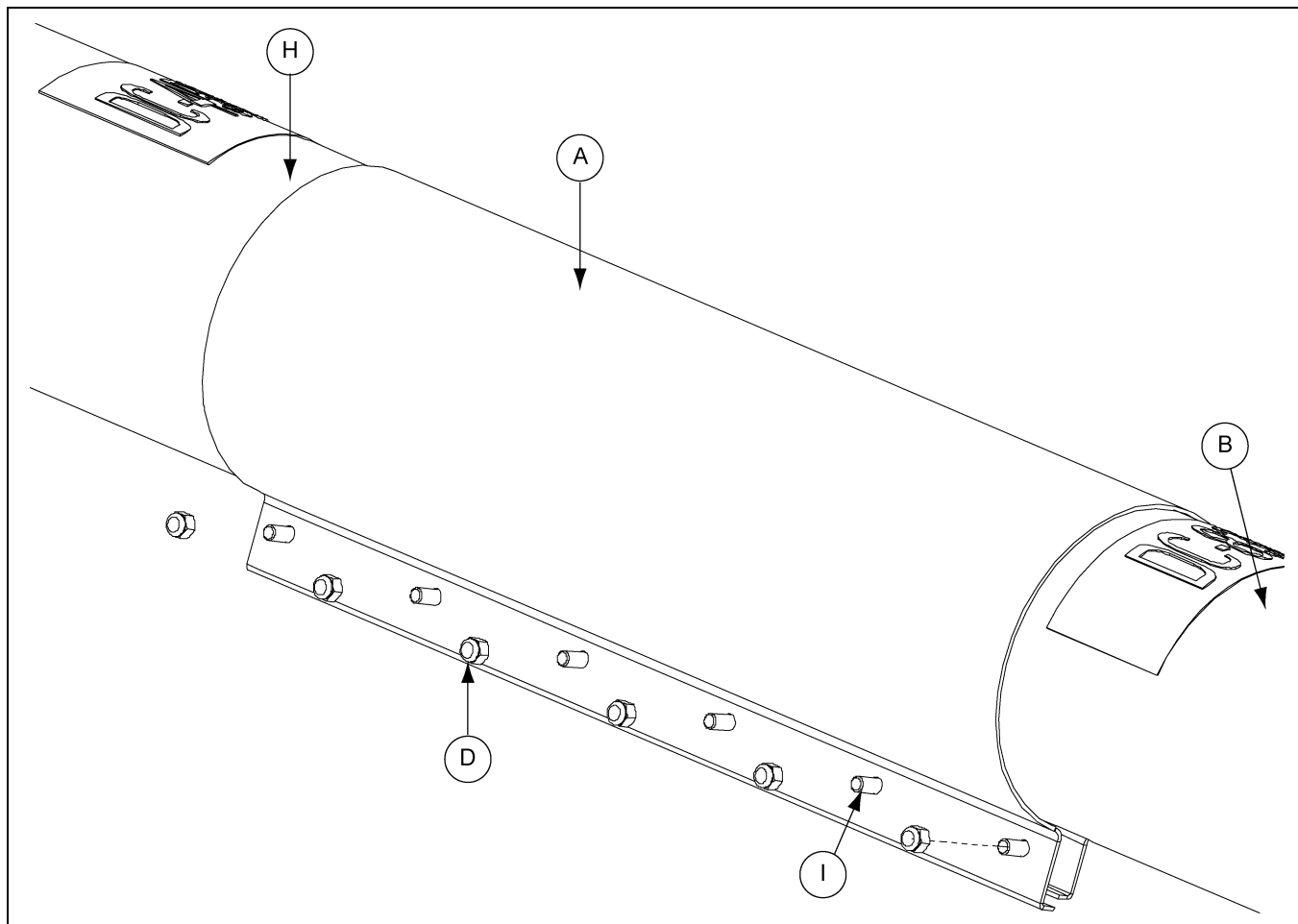

Figure 4D

Ref #	Description
A	Extension Connecting Band
B	Main Auger Tube
D	Bolt (<i>See Chart</i>)
H	Extension Tube
I	Nylock Nuts

4. Assembly and Installation

5. Insert the intake shaft (L) into the flight (J) and connect with proper grade 8 bolt (M) and stover nut (E).
(See Chart and See Figure 4E.)

Flight Hardware	
6"	3/8"-16 x 2" Grade 8 Hex Bolts
8"	7/16"-14 x 3" Grade 8 Hex Bolts
10"	1/2"-13 x 3-1/2" Grade 8 Hex Bolts

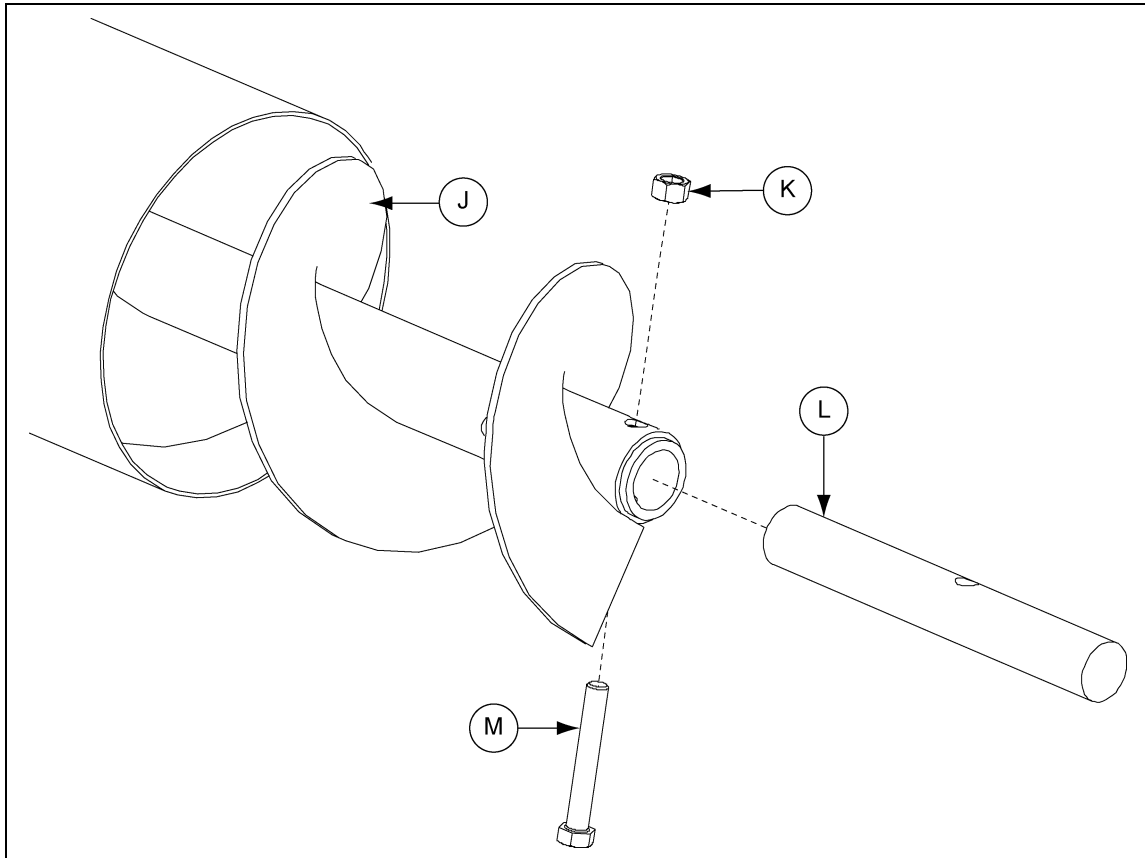

Figure 4E

Ref #	Description
J	Flight
K	Nut
L	Intake Shaft
M	Hex Bolts (See Chart)

6. The galvanized tube may need to be cut to expose enough auger flighting, depending on the application.

6" Units require 20". It is necessary to field cut auger tube lengths to accommodate required exposure. Butt the auger tube to the unloader tube and attach using a connecting band.

IMPORTANT: Auger stub shaft supplied is designed to fit GSI 6" Bulk Tank Augers. If using a different auger supplier it may be necessary to modify or fabricate a stub shaft for the unloader bearing.

Install the Truss Support

NOTE: For Bulk Tank Augers only.

1. Begin by placing the truss support (A) on the top side of the auger tube (D). Position the truss support half band (C) below the truss support (A) and align the holes. Attach together using appropriate hex bolt (B) and nylock nut (E). Do not tighten the nuts (E) down until the proper distance has been determined for the desired angle. (See Figure 4F.)

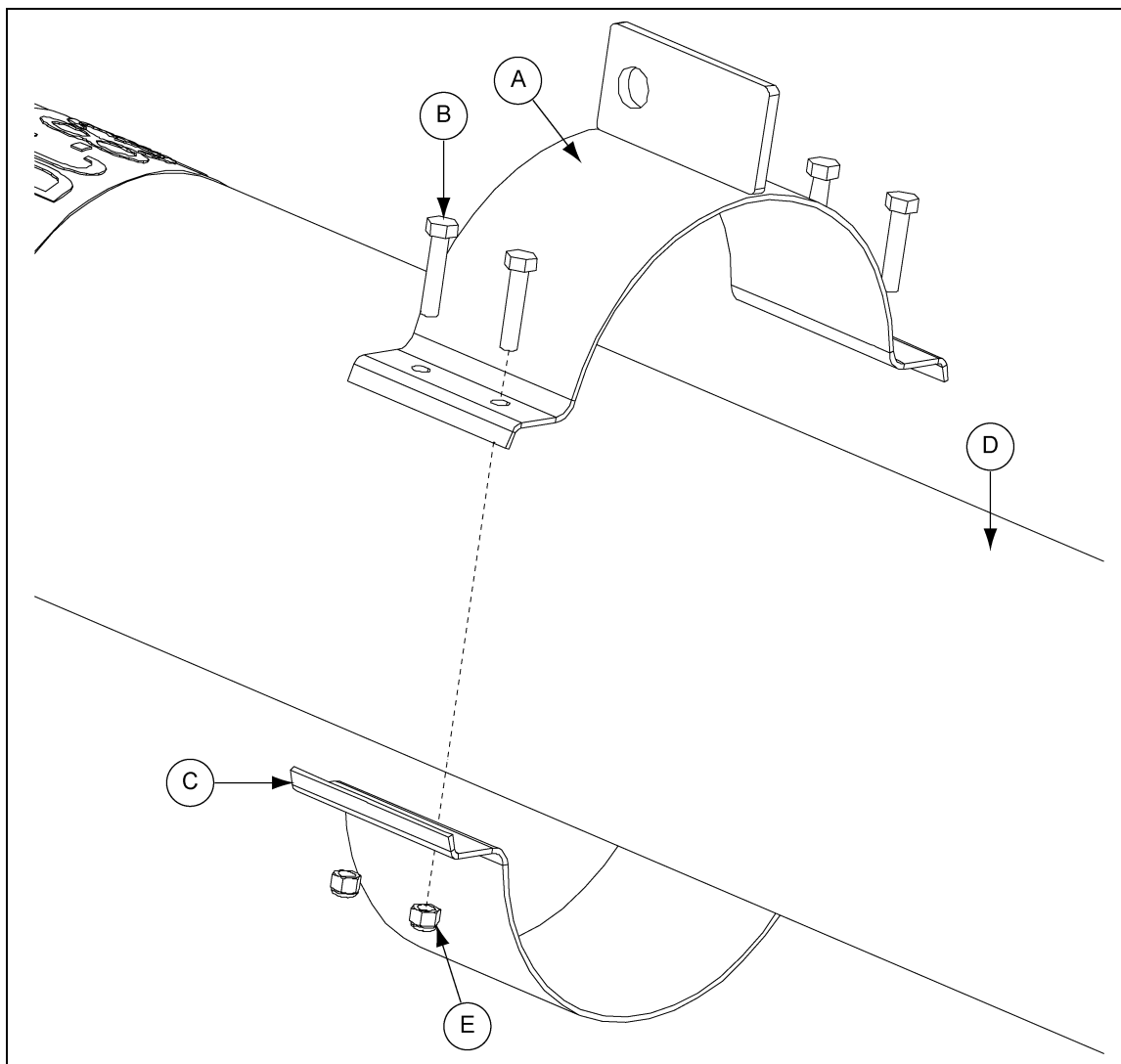

Figure 4F

Ref #	Description
A	Truss Support
B	Bolt
C	Truss Support Half Band
D	Auger Tube
E	Nylock Nuts

4. Assembly and Installation

Installing the Intake Guard

NOTE: For Utility Augers only.

1. Slide the intake guard (C) onto the auger tube (A) aligning the intake shaft (E) with the bronze bushing (D). (See Figure 4G.)

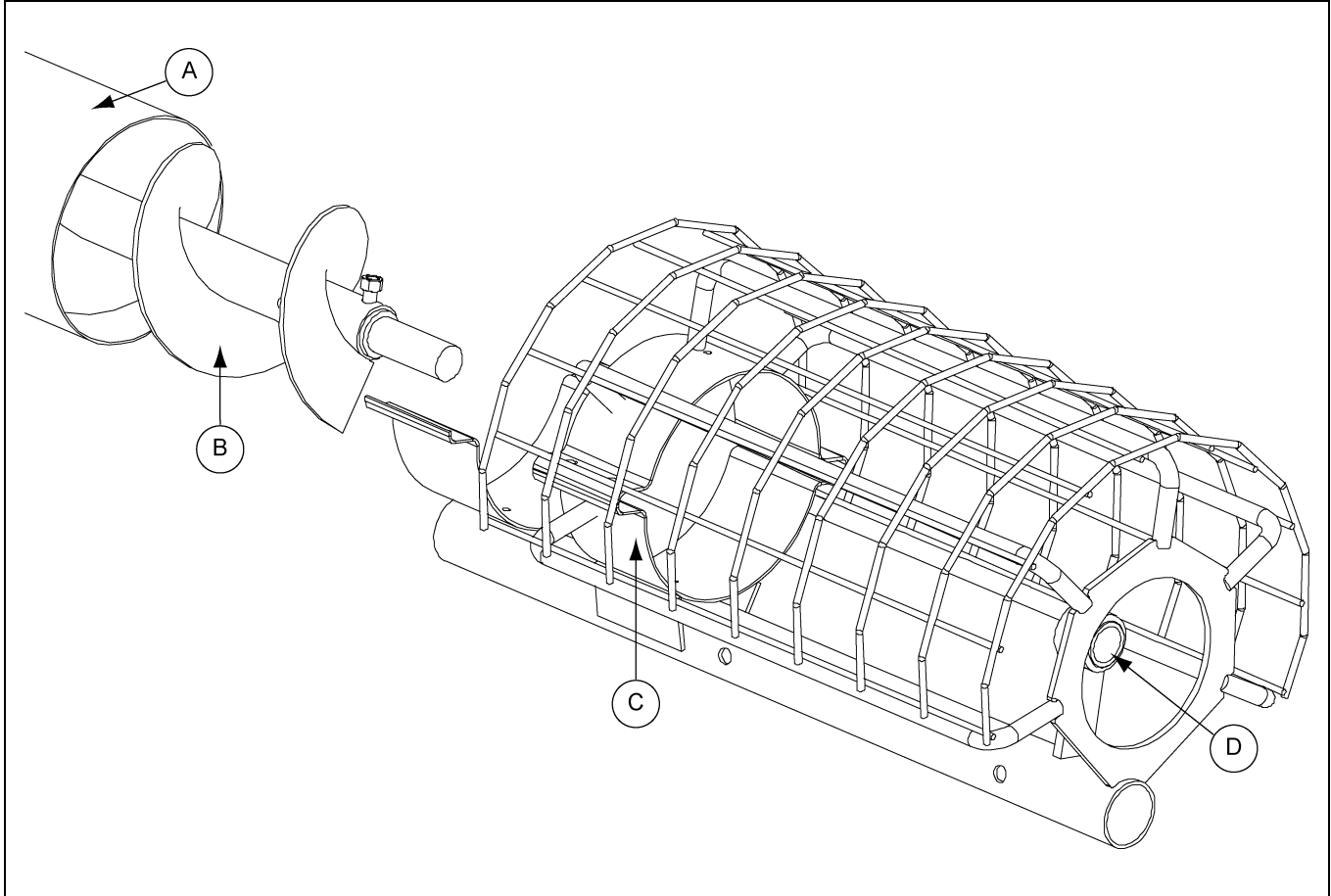

Figure 4G

Ref #	Description
A	Auger Tube
B	Flight
C	Intake Guard
D	Bronze Bushing

2. With the intake shaft (E) inserted in the bushing (F) make sure to leave approximately 1/2" of clearance between the end of the flight (G) and the face of the bushing (F). (See Figure 4H.)

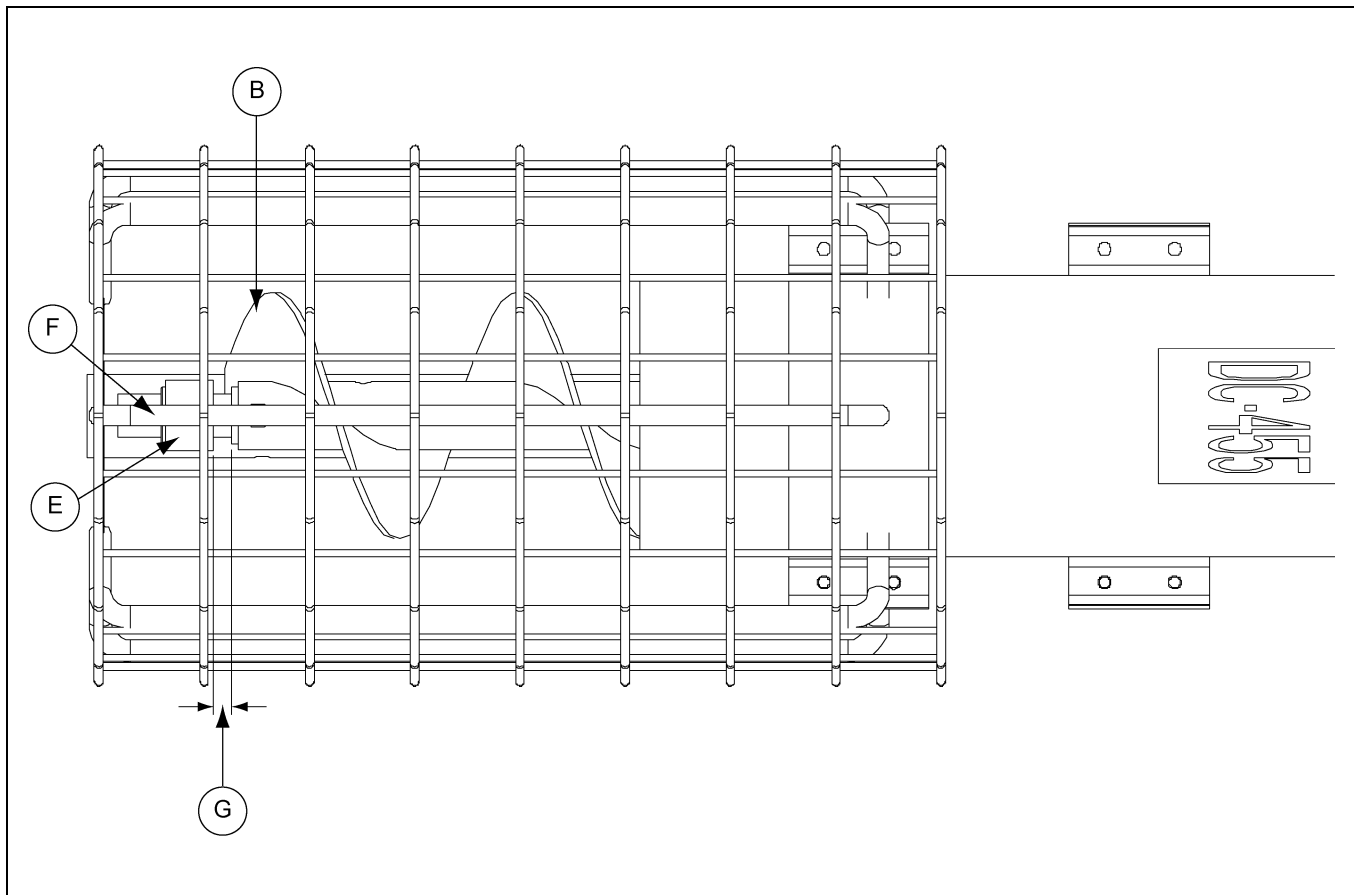

Figure 4H

Ref #	Description
B	Flight
E	Intake Shaft
F	Bushing
G	1/2" Between Bushing and Flight

4. Assembly and Installation

3. Attach the intake guard (C) to the tube (A) using the proper hex bolts (I) and nylock nuts (J) through the half bands (H) that are welded to the intake guard (C). (*See Chart* and *See Figure 4I.*)

Intake Guard Bolts	
6"	5/16"-18 x 1-3/4" Grade 5 Hex Bolt
8"	5/16"-18 x 1-3/4" Grade 5 Hex Bolt
10"	3/8"-16 x 1-1/2" Grade 5 Hex Bolt

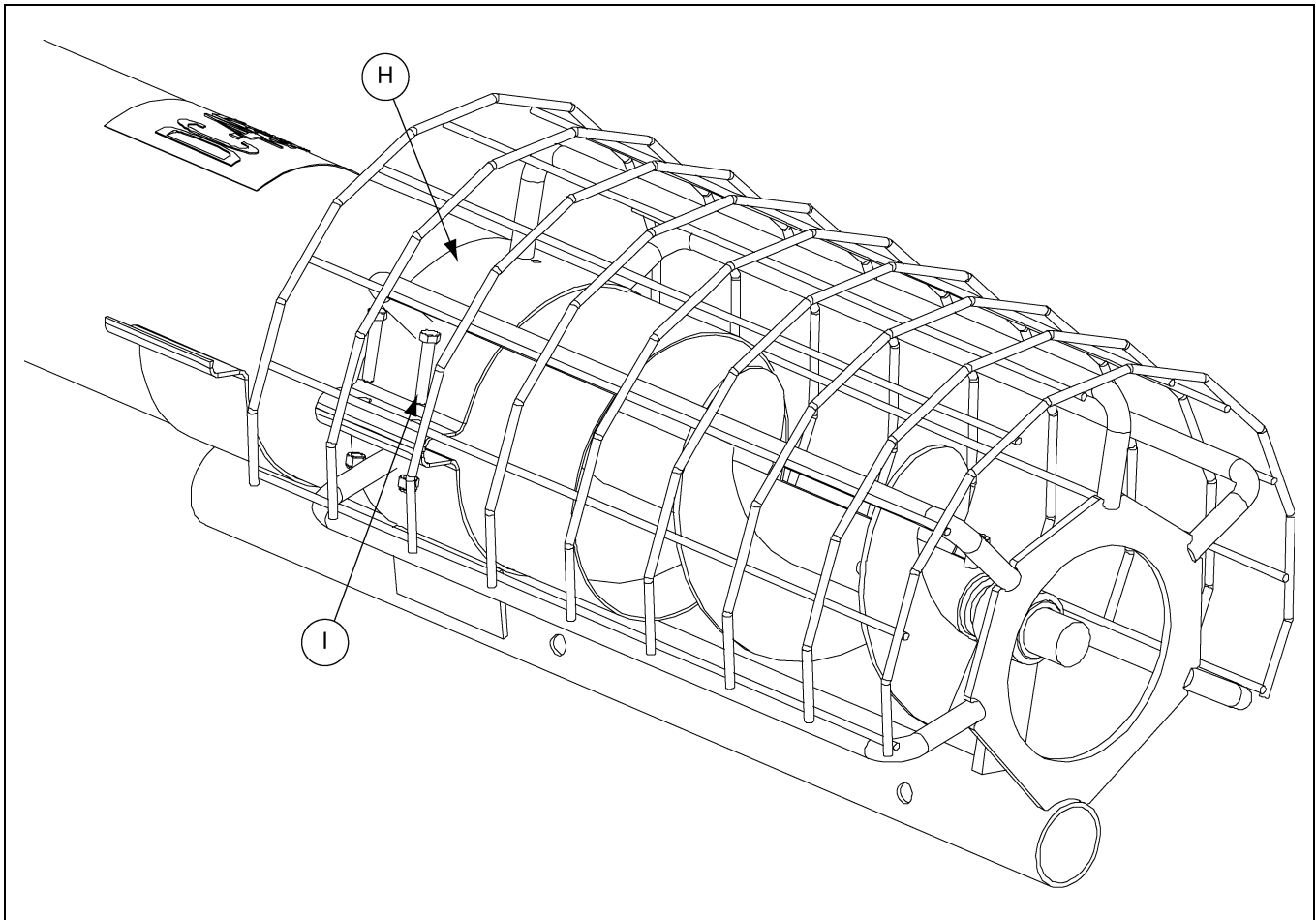

Figure 4I

Ref #	Description
H	Intake Guard Half Band
I	Bolt (<i>See Chart</i>)

4. Assembly and Installation

4. Place intake guard half band (H) above the lower half band on the intake guard (C) and attach using proper hex bolts (I) and nylock nuts (J). (See Chart on Page 22 and See Figure 4J.)

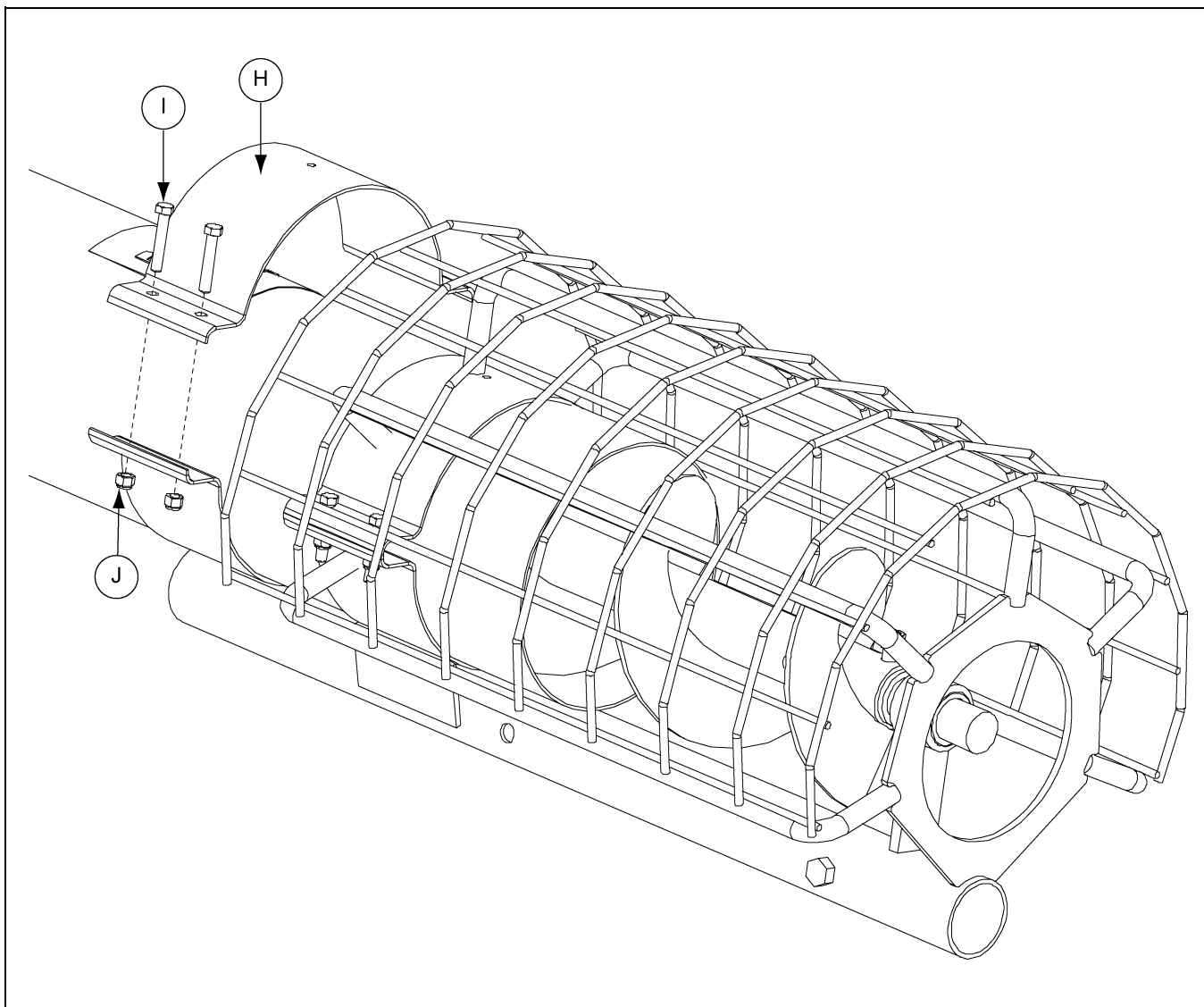

Figure 4J

Ref #	Description
H	Intake Guard Half Band
I	Bolt (See Chart on Page 22.)
J	Nylock Nut

4. Assembly and Installation

Installing Drive Shaft

1. Insert the drive shaft (C) into the opposite end of flight with keyway (A) facing outward. Align the holes in the shaft (C) and secure with grade 8 bolts (B) and stover nuts (D). (*See Chart* and *See Figure 4K.*)

Flight Hardware	
6"	3/8"-16 x 2" Grade 8 Hex Bolts
8"	7/16"-14 x 3" Grade 8 Hex Bolts
10"	1/2"-13 x 3-1/2" Grade 8 Hex Bolts

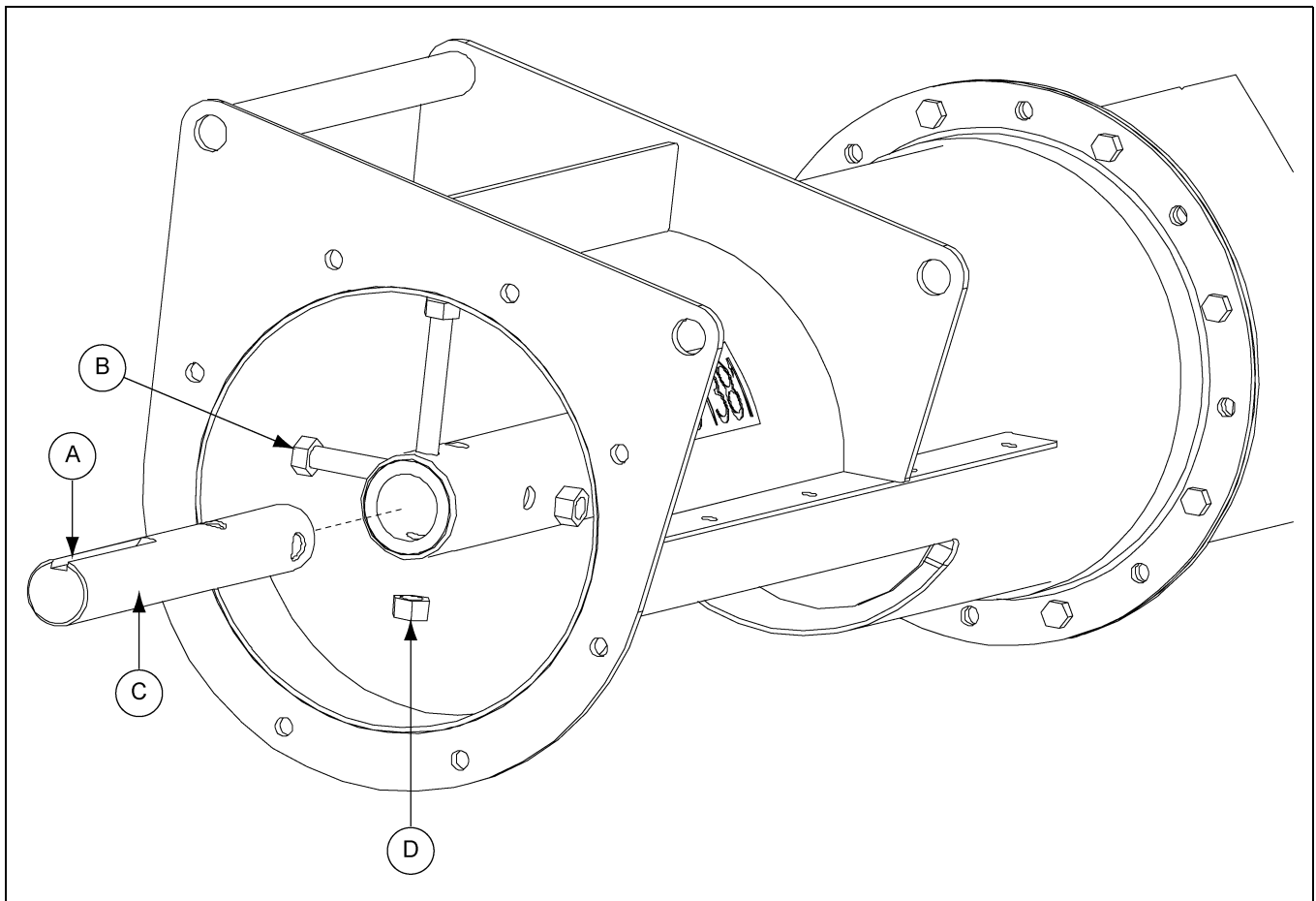

Figure 4K

Ref #	Description
A	Keyway
B	Bolt (<i>See Chart</i>)
C	Drive Shaft
D	Stover Nut

Mounting Bearing to Bearing Plate

1. Align bolt holes on bearing flange (E) with bolt holes on bearing plate (A).
2. Secure bearing to bearing plate (A) using appropriate bolts (B), lock washers (C), and nuts (D).
(See Chart and See Figure 4L.)

Bearing Bolts	
6"	7/16"-14 x 1-1/2" Hex Bolts
8" and 10"	1/2"-13 x 1-1/2" Hex Bolts

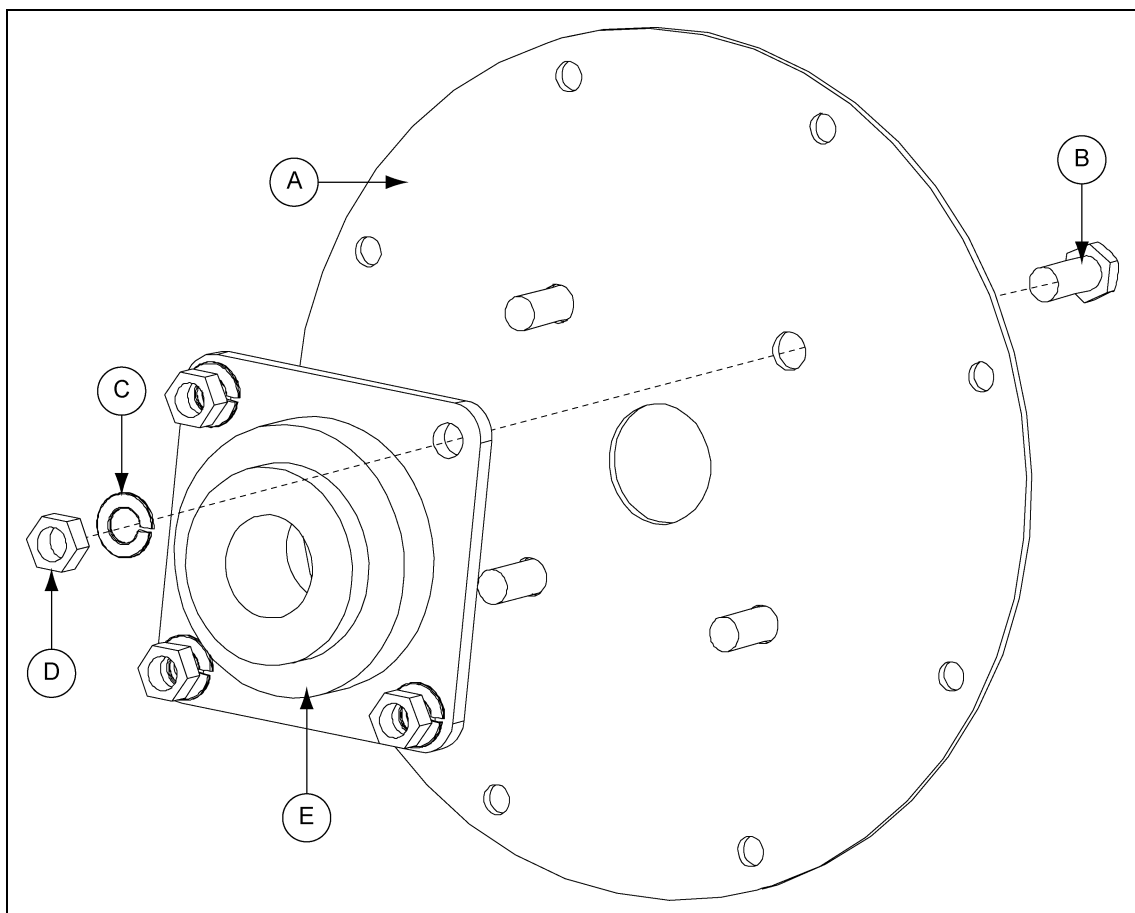

Figure 4L

Ref #	Description
A	Bearing Plate
B	Bolt (See Chart)
C	Lock Washer
D	Nut
E	Bearing Flange

4. Assembly and Installation

Installing Bearing Plate onto Tube

1. Align bearing with drive shaft (B) and slip shaft through bearing.
2. Rotate plate (A) until bolt holes in tube flange and plate (A) align. Secure with appropriate bolts (C), and serrated flange nuts (D). *(See Chart.)*

Bearing Plate Bolts	
6" and 8"	5/16"-18 x 1" Hex Bolts
10"	3/8"-16 x 1-1/4" Hex Bolts
10"	3/8"-16 x 1" Hex Bolts

3. Only secure with UPPER and LOWER four (4) bolts (C). *(See Figure 4M.)* The other four (4) bolts (C) will be installed later with the belt guard mounting brackets.

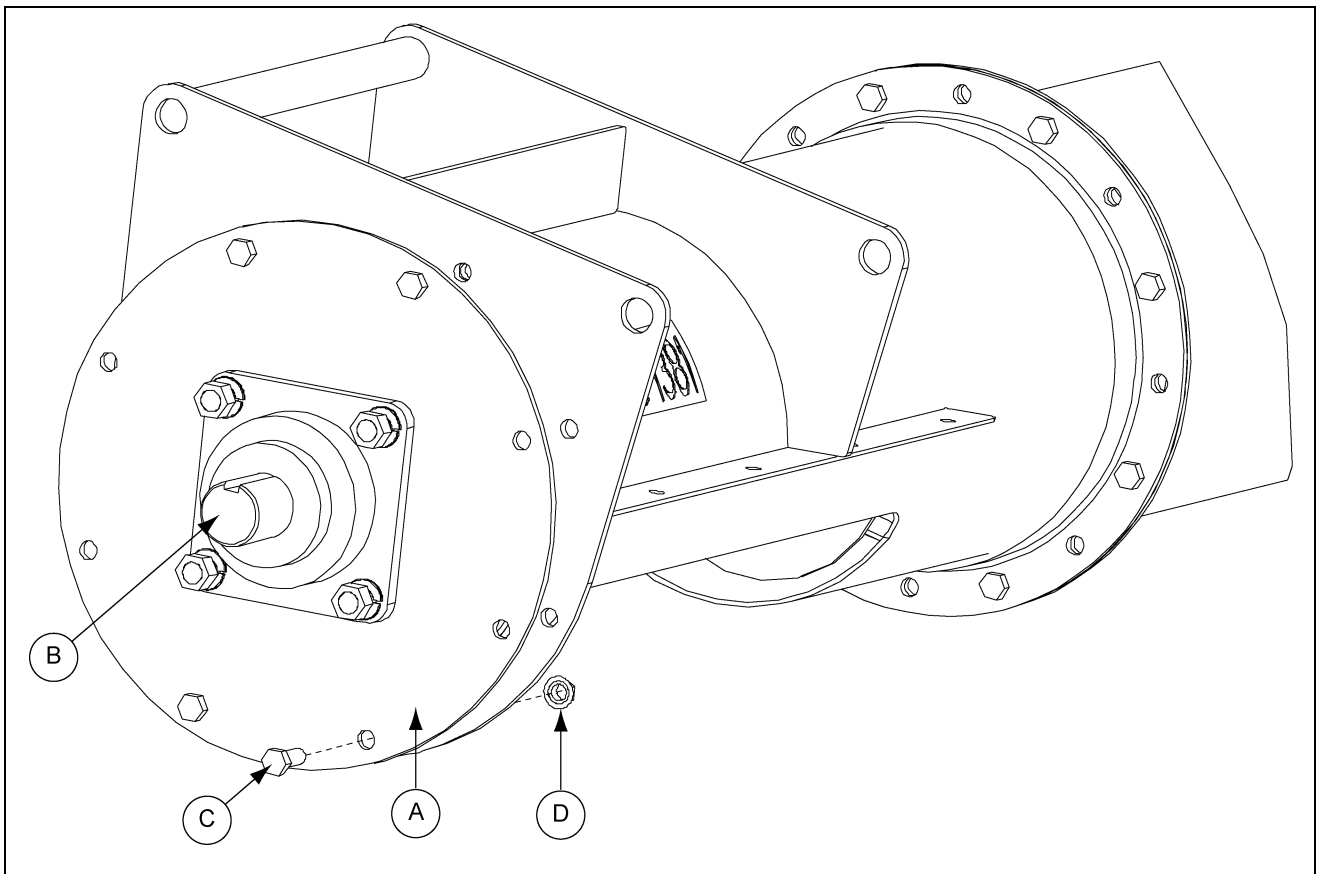

Figure 4M

Ref #	Description
A	Bearing Plate
B	Drive Shaft

Ref #	Description
C	Bolt <i>(See Chart)</i>
D	Serrated Flange Nut

NOTE: On the 10" systems, use the four (4) 3/8"-16 x 1" bolts in this step, the longer bolts will be used to attach the belt guard mounting brackets in a future step.

Installing the Motor Mount Adjuster

1. Place motor mount adjuster (B) between the back plate (F) and head plate (E) on the discharge tube.
2. Insert pivot rod (C) through the tube plates and motor mount adjuster (B). Secure in place with two (2) 3/16" x 2" cotter pins (D). (See Figure 4N.)

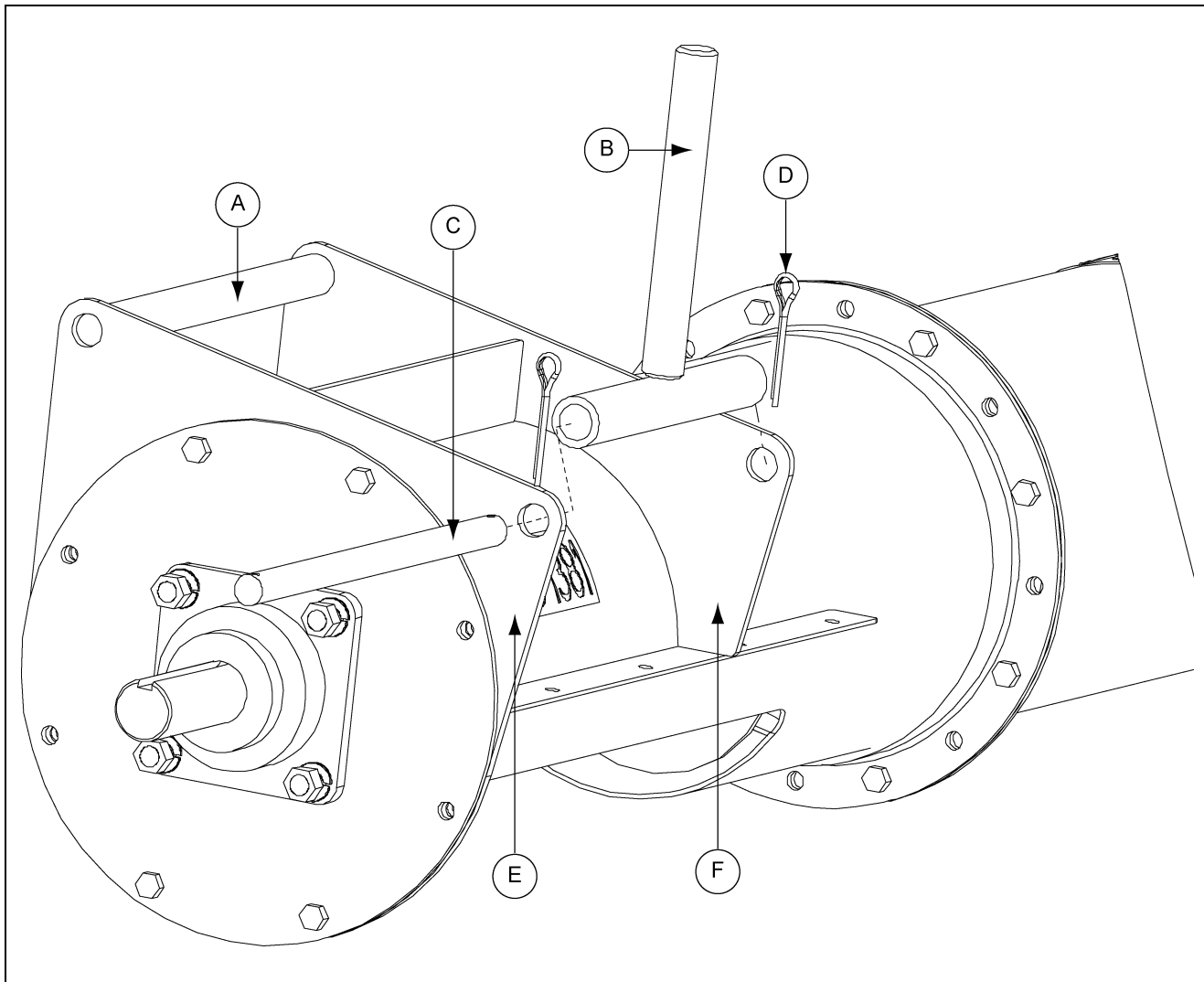

Figure 4N

Ref #	Description
A	Pivot Tube
B	Motor Mount Adjuster
C	Pivot Rod

Ref #	Description
D	Cotter Pin
E	Head Plate
F	Back Plate

4. Assembly and Installation

Installing the Motor Mount Plate

1. Secure one of the motor mount adjustment nuts (G) and one of the motor mount adjustment washers (H) approximately 3/4" of the way down the motor mount adjuster's threaded shaft (I).
2. Once the nut (G) and washer (H) is secure, slip the motor mount plate (A) over the adjuster and align the pivot holes (D) with the pivot tube (C). (See Figure 40.)

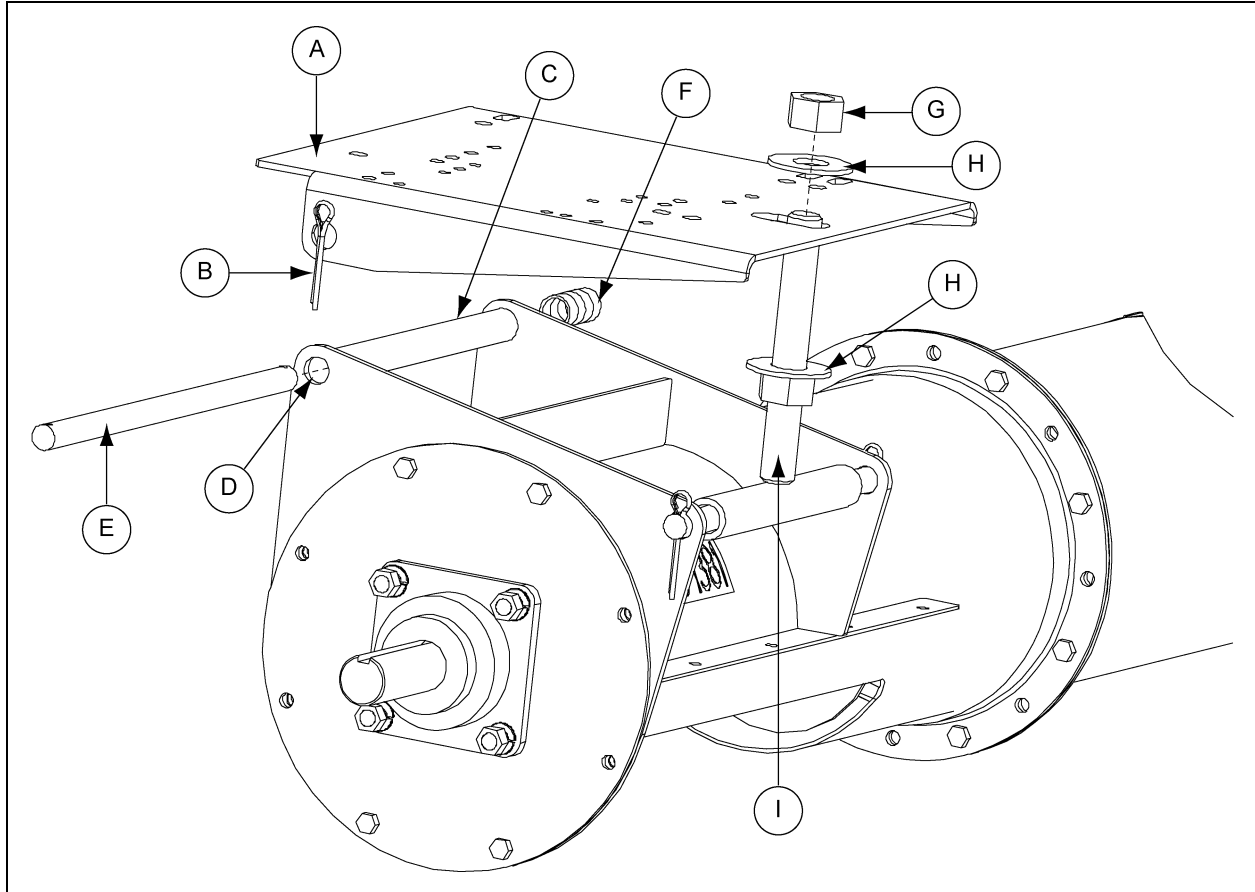

Figure 40

Ref #	Description
A	Motor Mount Plate
B	Cotter Pin
C	Pivot Tube
D	Pivot Hole
E	Motor Mount Pivot Rod
F	Spacer
G	Motor Mount Adjustment Nut
H	Motor Mount Adjustment Washer
I	Motor Mount Adjustment Shaft

4. Assembly and Installation

- Slide the motor mount pivot rod (E) through the pivot tube (C) on the discharge tube.
- When the pivot rod (E) begins to extend through the pivot tube (C), install the spacers (F) BETWEEN the back plate and the inner face of the motor mount plate (A). (See Figure 4P.)

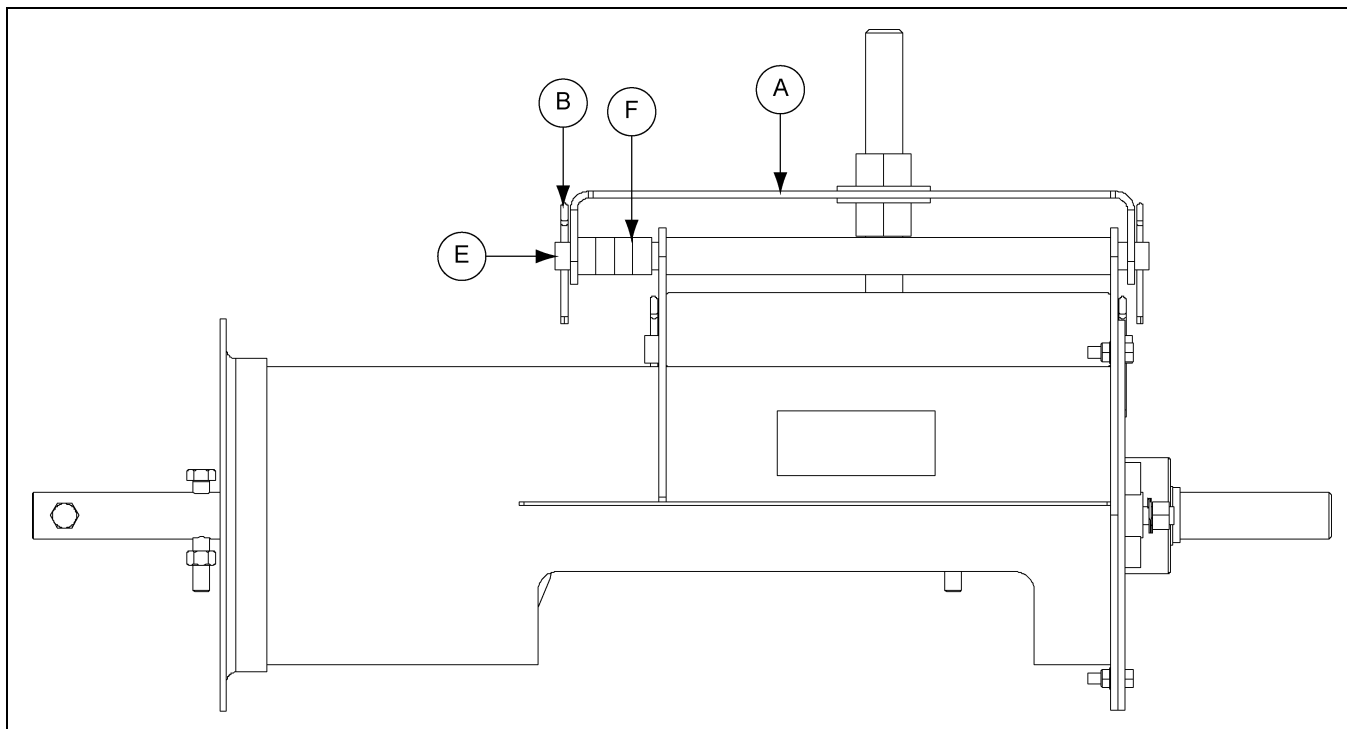

Figure 4P

Ref #	Description
A	Motor Mount Plate
B	Cotter Pin
E	Motor Mount Pivot Rod
F	Spacer

NOTE: The number of spacers will vary between each size of unloader.

4. Assembly and Installation

Installing the Belt Guard Brackets

1. Align the holes on the bearing plate (A) with the slots on the belt guard mounting brackets (E).
2. Secure the brackets (E) with proper bolts (B), flat washers (D), and serrated flange nuts (C).
(See Chart and See Figure 4Q.)

Bearing Bolts	
6" and 8"	5/16"-18 x 1" Hex Bolts
10"	3/8"-16 x 1-1/4" Hex Bolts

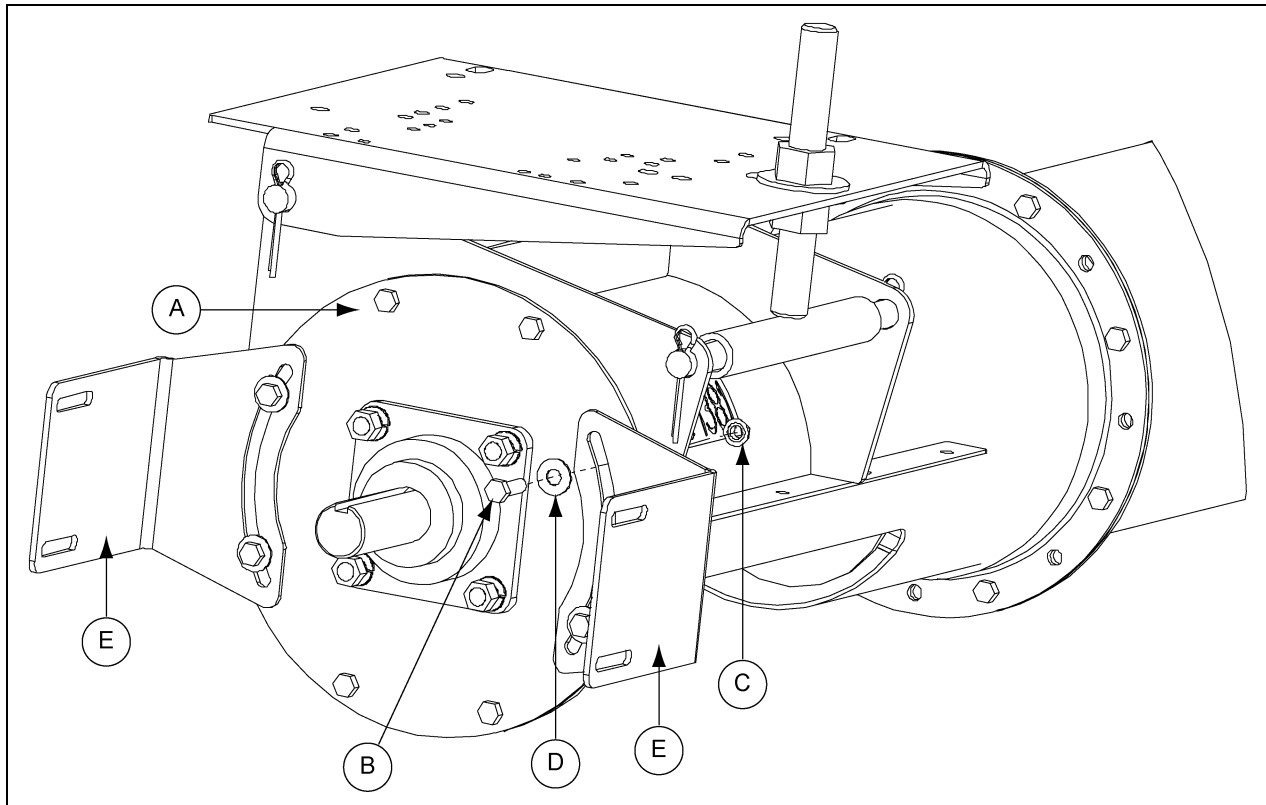

Figure 4Q

Ref #	Description
A	Bearing Plate
B	Bolt (See Chart)
C	Serrated Flange Nut
D	Flat Washer
E	Belt Guard Mounting Bracket

NOTE: DO NOT tighten the bolts completely. The brackets will need to be rotated to align the slot in the belt guard with the shafts on the motor and flight.

Installing the Lock Collar

1. Slide the lock collar (A) over the drive shaft (B), positioning it against the bearing. Do not tighten the lock collar (A) at this time as it will be tightened later in the assembly. (See Figure 4R.)

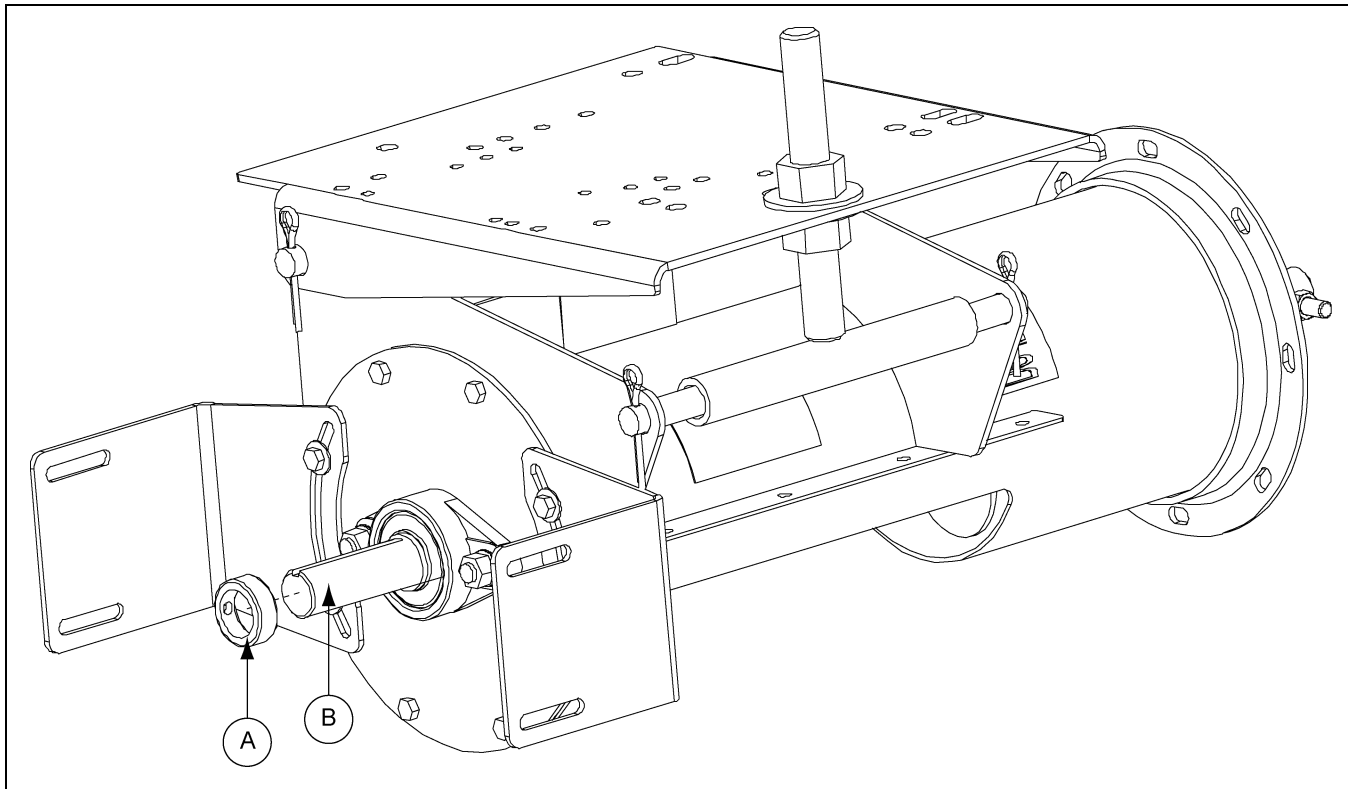

Figure 4R

Ref #	Description
A	Lock Collar
B	Drive Shaft

4. Assembly and Installation

Installing the Pulley

1. Place and position the key (B) into the keyway located on the drive shaft (D).
2. Place the pulley (C) onto the drive shaft (D) with the set screw (A) side of the pulley (C) facing away from the bearing plate (E). Position the pulley (C) so that it is as close to the lock collar as possible, but not touching it.
3. Once the pulley (C) is appropriately positioned, tighten the set screw (A) with a hex head wrench to secure it to the drive shaft (D). (See Figure 4S.)

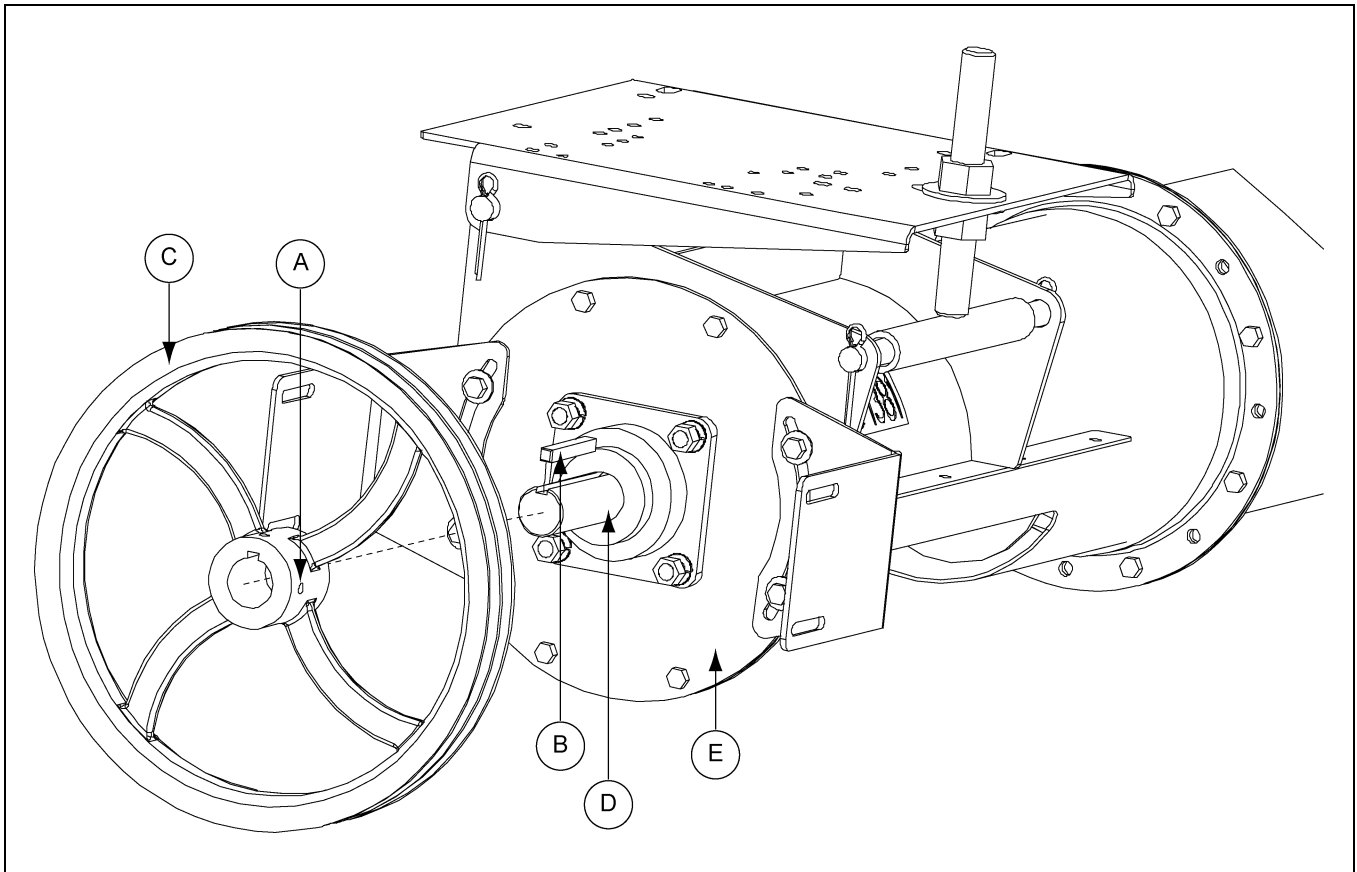

Figure 4S

Ref #	Description
A	Set Screw
B	Key
C	Flight Pulley
D	Drive Shaft
E	Bearing Plate

Tightening the Lock Collar

1. Using a punch and hammer, drive the lock collar clockwise (the same direction as the shaft rotation). Once the lock collar is set in place, use a hex head wrench to tighten the lock collar by tightening the set screw.

NOTE: *If the lock collar is not turned far enough, the set screw does not lock it into place.*

Installing the Motor (Not Provided)

1. Attach the motor to the motor mount plate (A) using appropriate bolts, lock washers, and hex nuts.
2. Install pulley (D) onto motor shaft making sure that it is aligned with the flight pulley (D). It may be necessary to move spacers (C) to gain shaft alignment. (See Figure 4T.)

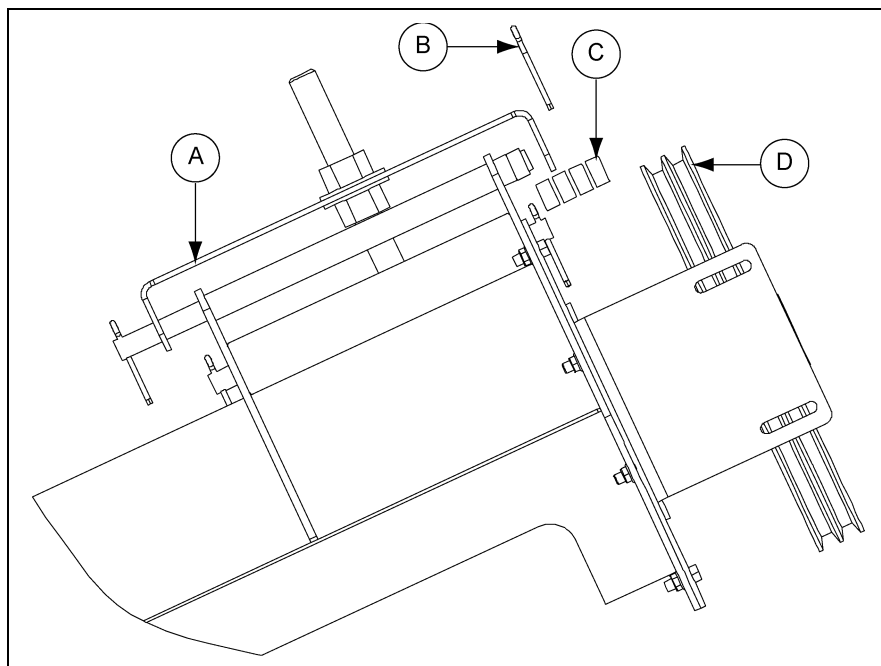

Figure 4T

Ref #	Description
A	Motor Mount Plate
B	Cotter Pin
C	Spacer
D	Flight Pulley

Motor Bolt Chart		
Motor Size	Hex Bolt Size	Qty
56	5/16"-18 x 1-1/4"	4
143T		
145T		
182T	3/8"-16 x 1-1/4"	4
184T		
213T		
215T		
254T	1/2"-13 x 1-3/4"	4
256T		

4. Assembly and Installation

Installing the Belts

1. Place the belts onto the pulleys.
2. First screw the lower motor mount adjustment nut upward, raising the motor mount plate, putting tension on the belts.
3. Once the desired tension is reached tighten the upper motor mount adjustment nut down onto the motor mount plate locking it into place.

Installing the Belt Guard

1. With the belts properly tensioned remove the bottom belt guard cover (F) and slip belt guard (A) down over motor shaft.
2. Bolt (B) the belt guard (A) to the belt guard mounting brackets (E), the brackets should still be loose at this time.
3. Align the motor shaft and the flight drive shaft in the belt guard's (A) slot, making sure that the belt guard (A) DOES NOT contact either pulley, and tighten down the belt guard mounting brackets (E) to the bearing plate. (See Figure 4U.)

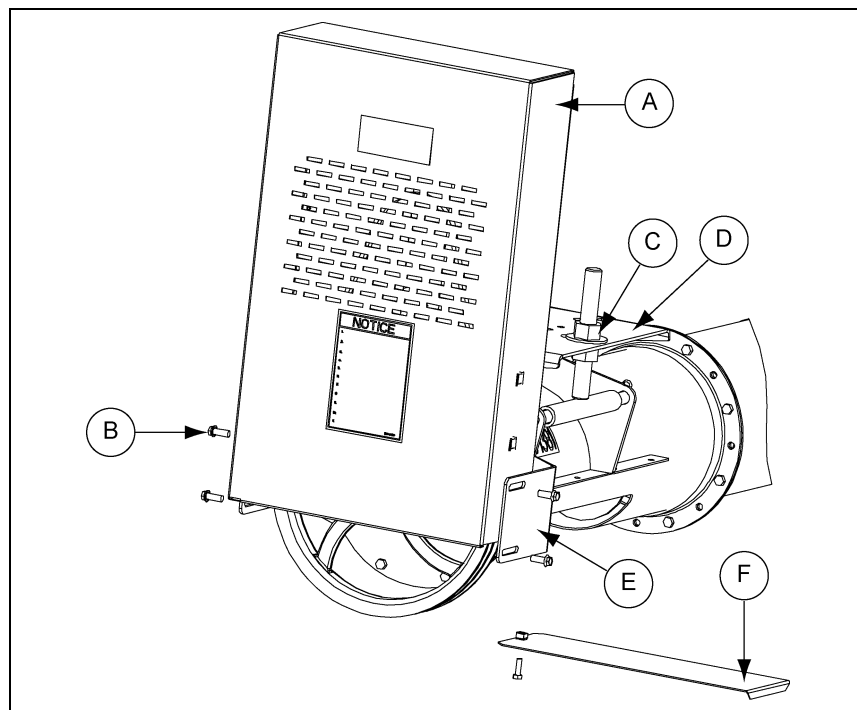

Figure 4U

Ref #	Description	Ref #	Description
A	Belt Guard	D	Motor Mount Plate
B	Bolt	E	Belt Guard Mounting Bracket
C	Motor Mount Adjustment Nut	F	Bottom Belt Guard Cover

4. Once the brackets are tightened slide the bottom cover back into place and secure with supplied bolt.

Horsepower Information for Electric Motors

- Horsepower recommendations are for augering reasonably dry grain at different angles. Grain with 15% moisture and above may require more horsepower if maximum capacity is to be maintained. Use a 2-1/2" to 3.0" motor pulley for a recommended auger speed of 550 RPM to 650 RPM motor pulley not furnished. Excessive wear will result if auger speed is in excess of 700 RPM and auger load up will occur if auger speed is less than 500 RPM or flow gate is required.
- Auger speeds in excess of 750 RPM should be avoided as excessive wear will result. Auger speed below 450 RPM require a flow control to restrict intake to the auger. High torque is required to turn the flighting if it is permitted to "load up" at low speed and damage to the auger can result. An optional control gate is available for this purpose.

This chart is a suggested horsepower requirement for standard Utility augers.

Horsepower Requirements	
Size	HP
6" x 11'	3/4
6" x 16'	1
6" x 21'	2
6" x 27'	3
6" x 33'	5
6" x 41'	5
8" x 11'	1-1/2
8" x 16'	2
8" x 21'	3
8" x 27'	3
8" x 33'	5
8" x 41'	5
8" x 53'	7 -1/2
10" x 21'	5
10" x 31'	7-1/2
10" x 41'	10



Electrical controls and wiring should be installed by a qualified electrician. The motor disconnect switches and conductor cables should comply with the National Electrical Code any local codes which apply. Motor starting control stations be located so that the operator can see that all personnel are clear of the equipment.

5. Electric Drive Motors

Power Source

1. Use electric motors that operate at 1750 RPM.
2. Electric motors and controls should be installed by a qualified electrician and must meet the standards set by the National Electrical Code and all local and state codes.
3. A magnetic starter should be used to protect the motor when starting and stopping. It should stop the motor in case of power interruption, conductor fault, low-voltage, circuit interruption, or motor overload. Then the motor must be restarted manually. Some motors have built-in thermal overload protection. If this type motor is used, use only those with a manual reset.



A main power disconnect switch capable of being locked only in the OFF position shall be provided. This shall be locked whenever work is being done on the auger.



Disconnect power before resetting motor overloads.



Make sure all electrical motors are grounded.



Reset and motor starting and stopping controls must be located so that the operator has full view of the entire operation.



Shut OFF power to adjust, service, or clean the machinery.



Keep all safety guards and shields in place.

Start-Up and Break-In



ALWAYS keep ALL guards and shields in place, until all the power is disconnected and locked out.

1. Make sure ALL belts are tensioned properly.
2. Make sure ALL shields are in place and that the belt(s) and pulley(s) are able to move freely.
3. Double check the assembly instructions to see that all parts have been assembled properly.
4. During operation of equipment, one person should be in a position to monitor the entire operation.

NOTE: *During the initial start-up and break-in period, the operator should note any unusual vibrations or noises and take the appropriate action.*



Make certain everyone is clear before operating or moving the machine.

5. The bin well inside the bin should have a control gate. The gate should be closed before start-up and closed before shut down to allow the machine to clean out.
6. The controls for the control gate should either pull or push open, depending on the type of well you have. Use the control gate to regulate a flow of less than full capacity until several hundred bushels of grain have been augered to polish the flighting assembly and tube.
7. Any new screw conveyor or one that has set idle for a season should go through a “break-in” period. This “break-in” consists of running the auger at half capacity until the screw becomes polished and smooth before attempting to run at full capacity. It is recommended that several hundred bushels of grain be augered at partial capacity.



Failure of the auger is very likely to occur if it is run at full capacity before the screw has become polished.



NEVER operate augers empty for any length of time as excessive wear will result.

8. Do not stop or start augers under load, especially before the flight and tube become well polished, as this may cause the auger to “lockup”.



Excessive wear will result if auger is run at speeds in excess of what is recommended.

9. Do not run auger at too slow speed, this will load up or over load the auger. An loading up of the auger will cause the motor to over load and a higher torque will be required to turn the auger, which in turn may cause damage to the auger.

7. Shut Down

Normal Shut Down

1. Make certain unloading tubes are empty before stopping the unit.
2. Disconnect and lock out the power source before leaving the work area.

Emergency Shut Down

1. Know how to shut down the auger in case of an emergency.
2. Disconnect and lock out the power source.
3. Close bin well control gates.
4. Clear out as much grain from the auger and hopper as you can.



Never restart when under a full load. Starting unit under load may result in damage to the machine. Such damage is considered abuse of the equipment.

5. Reconnect and unlock the power source.
6. Gradually clear the auger until there is no grain or obstructions.

Lock Out

1. Always stop and disconnect the power source whenever the operator must leave the work area or for maintenance of the machinery.
2. Make sure equipment is locked out and that the machinery cannot be started while the operator is not in the work area.



Use the type of main power disconnect switch that is capable of being locked only in the OFF position.

Storage Preparation

1. Close all wells to discharge auger tube.
2. Be sure the unload tube is empty.
3. Make sure power source is disconnected and locked out.
4. Check to see that all fasteners are secure.

Operate the Auger

NOTE: *The auger capacity can fluctuate greatly under varying conditions. Moisture content, different commodities, amount of foreign matter and speeds all play a part in the performance of the auger. Twenty-five percent (25%) moisture may cut capacity by as much as (40%) under some conditions.*

1. Make certain there are at least two (2) people in the work area to monitor operations at all times.
2. Visually inspect the auger periodically during operation.



Be alert for any unusual vibrations, noises and the loosening of any fasteners. If anything unusual is detected, immediately shut down the auger, disconnect and lock out the power source before servicing.

3. Consideration should be given to the proper size auger for a batch drying or any intermittent type operations. When augers are stopped and restarted under full load, it may result in damage to the auger. Using a larger diameter auger and reducing its load level will be far better than subjecting a smaller diameter auger to big loads. If an auger is kept from absolute filling, it will make start-up easier and will convey more efficiently.

Maintain the Auger



ALWAYS shut down and disconnect the power supply before adjusting, servicing or cleaning the equipment.

1. Use caution when repairing or replacing equipment parts.
2. Make sure ALL decals are legible and tightly attached to the auger. If necessary, replace them **FREE OF CHARGE** by contacting the dealer or the manufacturer.
3. Ensure that ALL electric motors, etc., are operating at the proper speed.
4. Maintain proper adjustments on the belt(s).
5. Mount controls for any electric motors at a safe distance from the machine and in a location accessible in case of an emergency.
6. Make sure ALL electrical wiring is not damaged, and that it meets proper wiring codes.
7. Make sure ALL components are in good working condition before use.
8. Check the auger flighting to make sure it is in good working condition.
9. Check the internal bearing bracket, bearing and universal joint to make sure they are in good working order.
10. Grease bearing at least two (2) times each season.

NOTES

1. **6" Utility and Bulk Auger Parts** *(See Pages 42 and 43.)*

2. **8" Utility and Bulk Auger Parts** *(See Pages 44 and 45.)*

3. **10" Utility and Bulk Auger Parts** *(See Pages 46 and 47.)*

6" Utility and Bulk Auger Parts

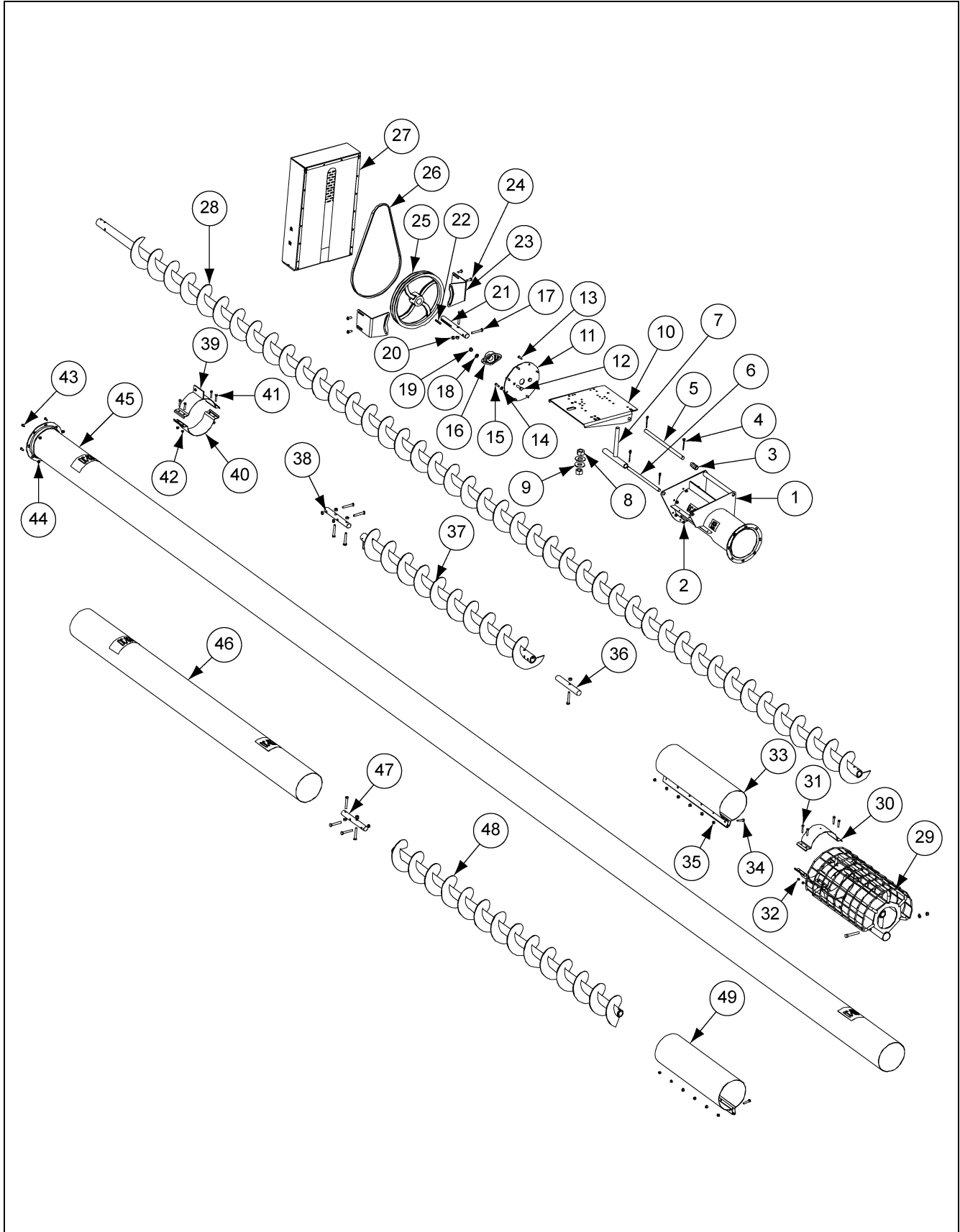

6" Utility and Bulk Auger Parts List

Ref #	Part #	Description
1	GK6996	Horizontal Power Head Tube
2	S-3611	Bearing Plate Serrated Flange Nut 5/16"-18
3	GK7014	Pivot Tube Spacer
4	S-6994	Pivot Tube Cotter Pin
5	GK7059	Motor Mount Pivot Rod
7	GK7060	Motor Mount Adjuster
8	S-3234	Motor Mount Adjuster Nut 3/4"-10
9	S-866	Motor Mount Adjuster Flat Washer 3/4"
10	GK7052-Y	Motor Mount Plate
11	GK7061-BS	Bearing Plate - Bin Silver
12	S-7837	Discharge Bearing Hex Bolt 7/16"-14 x 1-1/2"
13	S-1196	Bearing Plate Hex Bolt 5/16"-18 x 1"
14	S-845	Belt Guard Bracket Flat Washer 5/16"
15	S-1196	Belt Guard Bracket Hex Bolt 5/16"-18 x 1"
16	GK1049	Discharge Bearing 1" I.D. with 2 Hole Flanged
17	S-7687	Flight Connecting Hex Bolt 3/8"-16 x 2" Grade 8
18	S-7014	Discharge Bearing Lock Washer 7/16"
19	S-7332	Discharge Bearing Nut 7/16"-14
20	S-8251	Flight Connecting Stover Nut 3/8"-16
21	GK2025	Drive Shaft 1" O.D. x 10"
22	S-4513	Drive Shaft Square Key 1/4" x 2"
23	GK7062	Belt Guard Mounting Bracket
24	S-9065	Belt Guard Bolt 3/8"-16 x 1" Grade 5
25	GK1309	Sheave 12" O.D. x 1" I.D. - System (6" 1 Belt)
	GK1321	Sheave 12" O.D. x 1" I.D. - System (6" 2 Belt)
26	GK1323	Belt, B48 V-Belt
27	GK7005	Belt Guard
28	GK2854	Discharge Flight 6" x 11' - System (6" x 11')
	GK2855	Discharge Flight 6" x 16' - System (6" x 16')
	GK2856	Discharge Flight 6" x 21' - System (6" x 21')
	GK2856	Discharge Flight 6" x 21' - System (6" x 27')
	GK2856	Discharge Flight 6" x 21' - System (6" x 33')
	GK2856	Discharge Flight 6" x 21' - System (6" x 41')
29	GK3496-Y	Intake Guard
30	GK3986-Y	Intake Guard Half Band 6" x 4" 12 Gauge
31	S-7149	Intake Guard Hex Bolt 5/16"-18 x 1-3/4" Grade 5
32	S-7382	Intake Guard Nylock Nut 5/16"-18 Grade 5
33	GK1048	Extension Connecting Band 6" x 24"
34	S-7515	Connecting Band Hex Bolt 3/8"-16 x 1-1/2" Grade 5
35	S-7383	Connecting Band Nylock Nut 3/8"-16
36	GK1117	Intake Shaft 1" O.D. x 7"
37	GK4665	Extension Flight 6" x 6' 6-1/2" - System (6" x 27')
	GK5505	Extension Flight 6" x 12" - System (6" x 33')
	GK2893	Extension Flight 8" x 6' - System (6" x 41')
38	GK1351	Connecting Shaft 1" O.D. x 9-19/32"
39	GK2923	Truss Support - System (6" Bulk Tank)
40	GK1122	Truss Support Half Band 6" x 4" 12 Gauge - System (6" Bulk Tank)
41	S-2741	Truss Support Hex Bolt 5/16"-18 x 1-1/2" Grade 5 - System (6" Bulk Tank)
42	S-7382	Truss Support Nylock Nut 5/16"-18 Grade 5 - System (6" Bulk Tank)
43	S-275	Power Head Connecting Bin Bolt 5/16"-18 x 3/4"
44	S-3611	Power Head Connecting Serrated Flange Nut 5/16"-18
45	GK7082	Discharge Tube 6" x 9' - System (6" x 11')
	GK7083	Discharge Tube 6" x 14' - System (6" x 16')
	GK7084	Discharge Tube 6" x 19' - System (6" x 21')
	GK7202	Discharge Tube 6" x 24' 8" - System (6" x 27')
	GK7203	Discharge Tube 6" x 30' 8" - System (6" x 33')
	GK7084	Discharge Tube 6" x 19' - System (6" x 41')
46	GK2865	Extension Tube 6" x 20' - System (6" x 41')
47	GK1351	Connecting Shaft 1" O.D. x 9-19/32"
48	GK2859	Extension Flight 6" x 20' - System (6" x 41')
49	GK1048	Bulk Tank Connecting Band 6" x 24"

8" Utility and Bulk Auger Parts

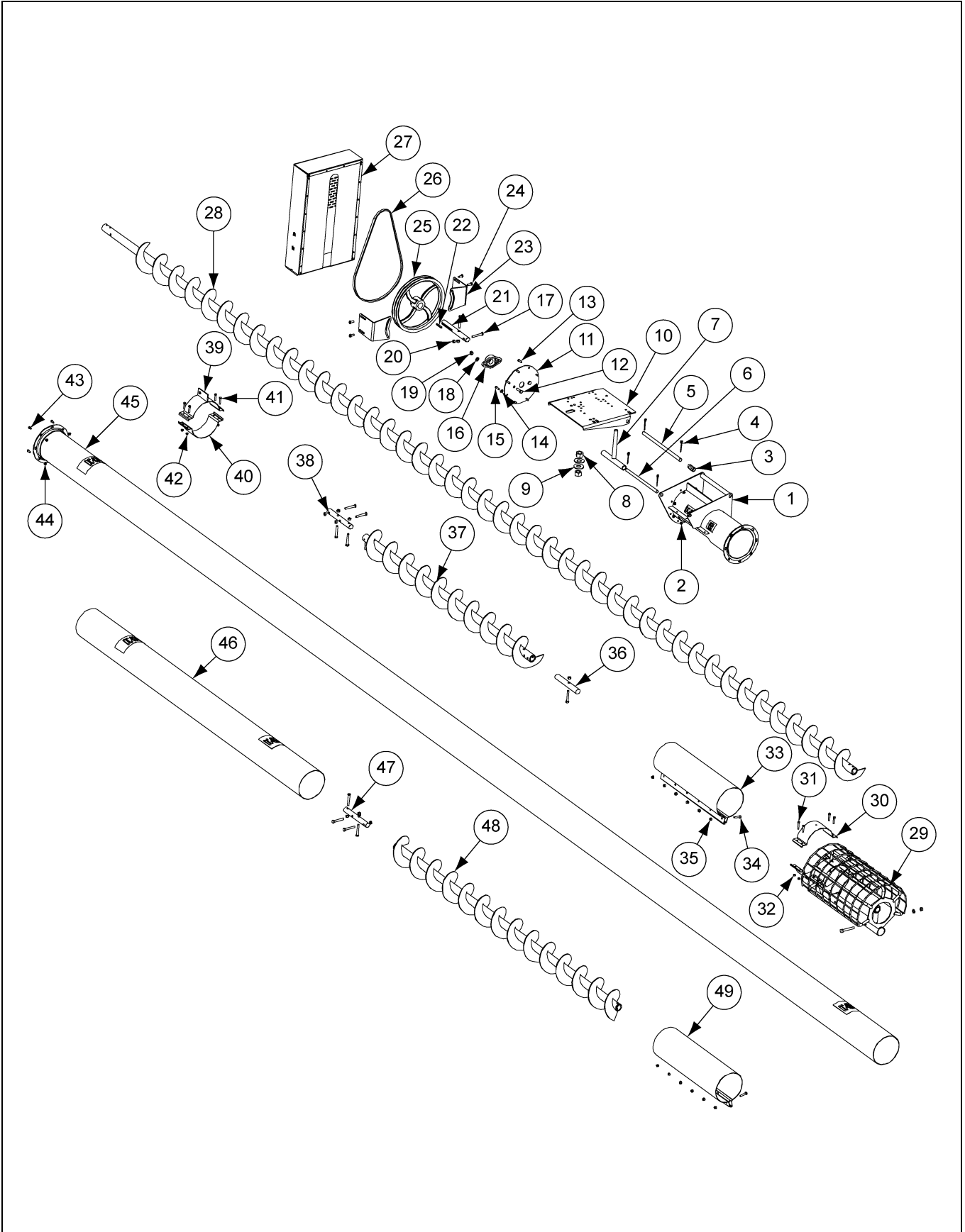

8" Utility and Bulk Auger Parts List

Ref #	Part #	Description
1	GK6997	Horizontal Power Head Tube
2	S-3611	Bearing Plate Serrated Flange Nut 5/16"-18
3	GK7014	Pivot Tube Spacer
4	S-6994	Pivot Tube Cotter Pin
5	GK7013	Motor Mount Pivot Rod
6	GK7012	Motor Mount Adjustment Rod
7	GK6942	Motor Mount Adjuster
8	S-240	Motor Mount Adjuster Nut 1"-8
9	S-7835	Motor Mount Adjuster Flat Washer 1"
10	GK6986-Y	Motor Mount Plate
11	GK6987-BS	Bearing Plate - Bin Silver
12	S-8760	Discharge Bearing Hex Bolt 1/2"-13 x 1-1/2"
13	S-1196	Bearing Plate Hex Bolt 5/16"-18 x 1"
14	S-845	Belt Guard Bracket Flat Washer 5/16"
15	S-1196	Belt Guard Bracket Hex Bolt 5/16"-18 x 1"
16	GK1330	Discharge Bearing 1-1/4" I.D. with 2 Hole Flanged
17	S-8316	Flight Connecting Hex Bolt 7/16"-14 x 3" Grade 8
18	S-236	Discharge Bearing Lock Washer 1/2"
19	S-7510	Discharge Bearing Nut 1/2"-13
20	S-8317	Flight Connecting Stover Nut 7/16"-14
21	GK1331	Drive Shaft 1-1/4" O.D. x 10-1/2"
22	S-4513	Drive Shaft Square Key 1/4" x 2"
23	GK7006	Belt Guard Mounting Bracket
24	S-9065	Belt Guard Bolt 3/8"-16 x 1" Grade 5
25	GK1335	Sheave 12" O.D. x 1-1/4" I.D.
26	GK1952	Belt, B50 V-Belt
27	GK7005	Belt Guard
28	GK2879	Discharge Flight 8" x 11' - System (8" x 11')
	GK2880	Discharge Flight 8" x 16' - System (8" x 16')
	GK2881	Discharge Flight 8" x 21' - System (8" x 21')
	GK2882	Discharge Flight 8" x 27' - System (8" x 27')
	GK2882	Discharge Flight 8" x 27' - System (8" x 33')
	GK2882	Discharge Flight 8" x 27' - System (8" x 41')
29	GK3501-Y	Intake Guard
	GK5118-Y	Intake Guard Half Band 8" x 4" 12 Gauge
30	S-7149	Intake Guard Hex Bolt 5/16"-18 x 1-3/4" Grade 5
31	S-7382	Intake Guard Nylock Nut 5/16"-18 Grade 5
32	GK1015	Extension Connecting Band 8" x 27"
33	S-8322	Connecting Band Hex Bolt 3/8"-16 x 1-3/4" Grade 5
34	S-7383	Connecting Band Nylock Nut 3/8"-6
35	GK1884	Intake Shaft 1-1/4" O.D. x 9"
36	GK5101	Extension Flight 8" x 6' - System (8" x 33')
	GK5101	Extension Flight 8" x 6' - System (8" x 41')
	GK5101	Extension Flight 8" x 6' - System (8" x 53')
37	GK1328	Connecting Shaft 1-1/4" O.D. x 9-1/2"
38	GK2922	Truss Support
39	GK1059	Truss Support Half Band
40	S-2741	Truss Support Hex Bolt 5/16"-18 x 1-1/2" Grade 5
41	S-7382	5/16"-18 Grade 5 Nylock Nut
42	S-275	Power Head Connecting Bin Bolt 5/16"-18 x 3/4"
43	S-3611	Power Head Connecting Serrated Flange Nut 5/16"-18
44	GK7079	Discharge Tube 8" x 8' - System (8" x 11')
	GK7080	Discharge Tube 8" x 13' - System (8" x 16')
	GK7081	Discharge Tube 8" x 18' - System (8" x 21')
	GK7204	Discharge Tube 8" x 24' - System (8" x 27')
	GK7205	Discharge Tube 8" x 30' - System (8" x 33')
	GK7205	Discharge Tube 8" x 30' - System (8" x 41')
45	GK7205	Discharge Tube 8" x 30' - System (8" x 53')
	GK2877	Extension Tube 8" x 8' - System (8" x 41')
46	GK2878	Extension Tube 8" x 20' - System (8" x 53')
	GK1328	Connecting Shaft 1-1/4" O.D. x 9-1/2"
47	GK2884	Extension Flight 8" x 8' 3/16" - System (8" x 41')
	GK2885	Extension Flight 8" x 20' 3/16" - System (8" x 53')
48	GK1015	Bulk Tank Connecting Band 8" x 27"

10" Utility and Bulk Auger Parts

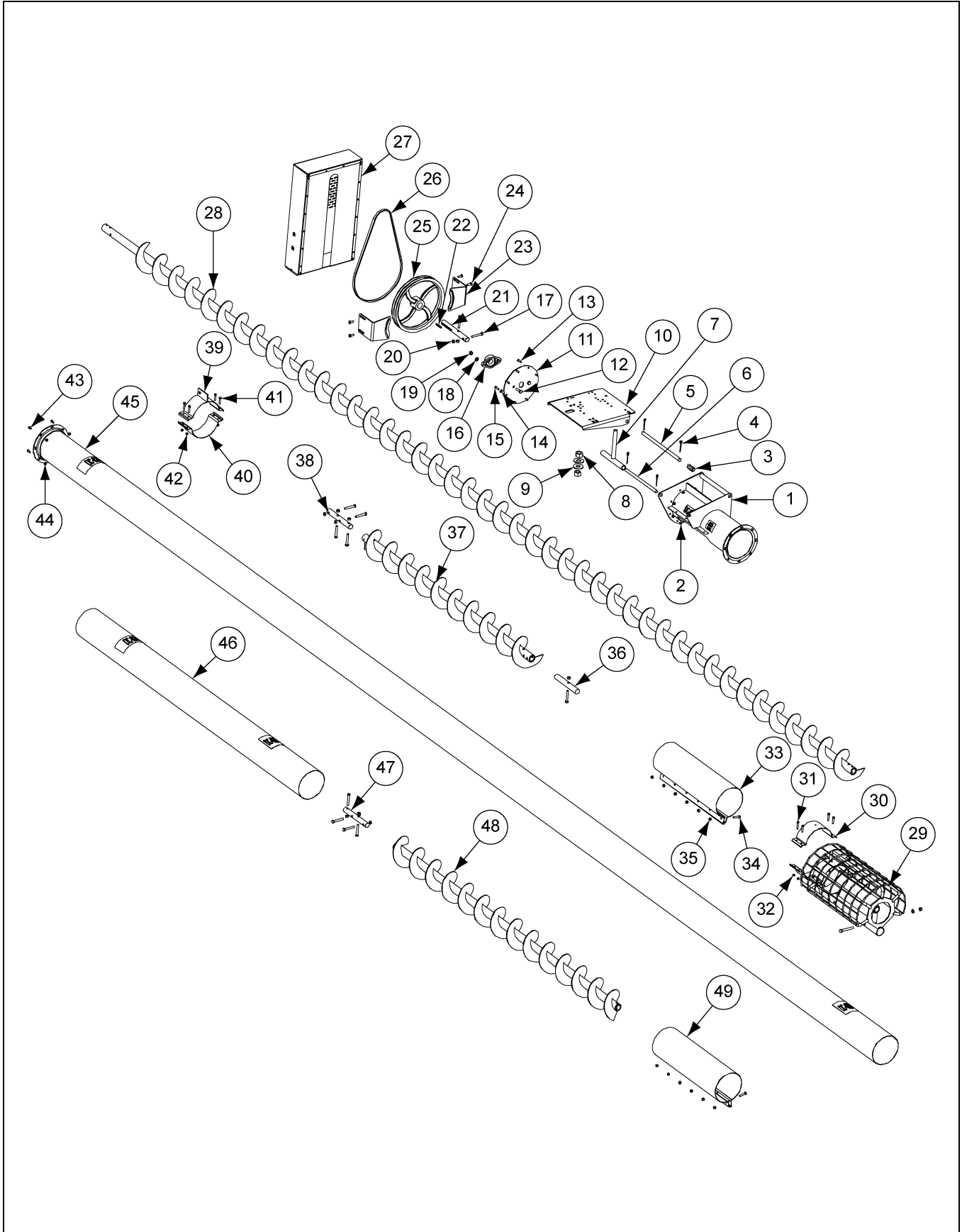

10" Utility and Bulk Auger Parts

Ref #	Part #	Description
1	GK6998	Horizontal Power Head Tube
2	S-968	Bearing Plate Serrated Flange Nut 3/8"-16
3	GK7014	Pivot Tube Spacer
4	S-6994	Pivot Tube Cotter Pin
5	GK7013	Motor Mount Pivot Rod
6	GK7012	Motor Mount Adjustment Rod
7	GK6942	Motor Mount Adjuster
8	S-240	Motor Mount Adjuster Nut 1"-8
9	S-7835	Motor Mount Adjuster Flat Washer 1"
10	GK6986-Y	Motor Mount Plate
11	GK7017-BS	Bearing Plate - Bin Silver
12	S-8760	Discharge Bearing Hex Bolt 1/2"-13 x 1-1/2"
13	S-7469	Bearing Plate Hex Bolt 3/8"-16 x 1"
14	S-248	Belt Guard Bracket Flat Washer 3/8"
15	S-2071	Belt Guard Bracket Hex Bolt 3/8"-16 x 1-1/4"
16	GK1343	Discharge Bearing 1-1/2" I.D. with 2 Hole Flanged
17	S-8314	Flight Connecting Hex Bolt 1/2"-13 x 3-1/2" Grade 8
18	S-236	Discharge Bearing Lock Washer 1/2"
19	S-7510	Discharge Bearing Nut 1/2"-13
20	S-8315	Flight Connecting Stover Nut 1/2"-13
21	GK1289	Drive Shaft 1-1/2" O.D. x 11-1/2"
22	S-9181	Drive Shaft Square Key 3/8" x 3"
23	GK7018	Belt Guard Mounting Bracket
24	S-9065	Belt Guard Bolt 3/8"-16 x 1" Grade 5
25	GK1345	Sheave 15" O.D. x 1-1/2" I.D.
26	GK1346	Belt, B57 V-Belt
27	GK7005	Belt Guard
28	GK5143	Discharge Flight 10" x 11' - System (10" x 11')
	GK5144	Discharge Flight 10" x 16' - System (10" x 16')
	GK5130	Discharge Flight 10" x 21' - System (10" x 21')
	GK5130	Discharge Flight 10" x 21' - System (10" x 31')
	GK5130	Discharge Flight 10" x 21' - System (10" x 41')
29	GK3502-Y	Intake Guard
30	GK5117-Y	Intake Guard Half Band 10" x 4" 7 Gauge
31	S-7515	Intake Guard Hex Bolt 3/8"-16 x 1-1/2" Grade 5
32	S-7383	Intake Guard Nylock Nut 3/8"-16 Grade 5
33	GK1883	Extension Connecting Band 10" x 30"
34	S-7515	Connecting Band Hex Bolt 3/8"-16 x 1-1/2" Grade 5
35	S-8251	Connecting Band Stover Nut 3/8"-16
36	GK2907	Intake Shaft 1-1/2" O.D. x 9-1/2"
37	GK5157	Extension Flight 10" x 10' - System (10" x 31')
	GK5161	Extension Flight 10" x 20' - System (10" x 41')
38	GK1339	Connecting Shaft 1-1/2" O.D. x 9-1/2"
43	S-7520	Power Head Connecting Bin Bolt 3/8"-16 x 1"
44	S-456	Power Head Connecting Hex Nut 3/8"-16
45	GK7095	Discharge Tube 10" x 7' 6" - System (10" x 11')
	GK7096	Discharge Tube 10" x 12' 6" - System (10" x 16')
	GK7097	Discharge Tube 10" x 17' 6" - System (10" x 21')
	GK7097	Discharge Tube 10" x 17' 6" - System (10" x 31')
	GK7097	Discharge Tube 10" x 17' 6" - System (10" x 41')
46	GK2899	Extension Tube 10" x 10' - System (10" x 31')

10. Troubleshooting

Problem	Possible Cause	Corrective Action
The auger is vibrating.	<ol style="list-style-type: none"> 1. Damage can occur to the auger flighting, causing noise. Damage usually is caused from foreign material being run through the auger. 2. Drive belt may be overtightened, putting head stub and flight in a bind. 	<ol style="list-style-type: none"> 1. It may be necessary to remove the flighting for inspection. 2. Loosen the drive belts.
Capacity is too low.	<ol style="list-style-type: none"> 1. There may not be enough grain reaching the auger. 2. The auger is moving too slowly. 	<ol style="list-style-type: none"> 1. Make sure the intake has not bridged over, restricting flow. The flighting at the intake should be covered with grain for maximum capacity. 2. Check the auger speed. Low capacity will result from speeds slower than recommended.
The auger plugs.	<ol style="list-style-type: none"> 1. The auger may be "jamming" because too much grain is reaching the auger. 2. The grain may be wet. 3. The auger may be jammed with foreign material. 4. The motor may be too small or wired incorrectly. 	<ol style="list-style-type: none"> 1. Use the control gates to decrease the amount of grain the auger is gathering. 2. If wet grain or other hard-to-move material is being augered, use a larger size motor than recommended for normal use. 3. Remove any foreign material in the auger. 4. Check wiring or consider using the next larger size motor.

GSI Group, LLC Limited Warranty

The GSI Group, LLC ("GSI") warrants products which it manufactures to be free of defects in materials and workmanship under normal usage and conditions for a period of 12 months after sale to the original end-user or if a foreign sale, 14 months from arrival at port of discharge, whichever is earlier. The end-user's sole remedy (and GSI's only obligation) is to repair or replace, at GSI's option and expense, products that in GSI's judgment, contain a material defect in materials or workmanship. Expenses incurred by or on behalf of the end-user without prior written authorization from the GSI Warranty Group shall be the sole responsibility of the end-user.

Warranty Extensions:

The Limited Warranty period is extended for the following products:

	Product	Warranty Period	
AP Fans and Flooring	Performer Series Direct Drive Fan Motor	3 Years	* Warranty prorated from list price: 0 to 3 years - no cost to end-user 3 to 5 years - end-user pays 25% 5 to 7 years - end-user pays 50% 7 to 10 years - end-user pays 75%
	All Fiberglass Housings	Lifetime	
	All Fiberglass Propellers	Lifetime	
AP and Cumberland	Flex-Flo/Pan Feeding System Motors	2 Years	
Cumberland Feeding/Watering Systems	Feeder System Pan Assemblies	5 Years **	** Warranty prorated from list price: 0 to 3 years - no cost to end-user 3 to 5 years - end-user pays 50%
	Feed Tubes (1-3/4" and 2.00")	10 Years *	
	Centerless Augers	10 Years *	
	Watering Nipples	10 Years *	
Grain Systems	Grain Bin Structural Design	5 Years	
Grain Systems Farm Fans Zimmerman	Portable and Tower Dryers	2 Years	† Motors, burner components and moving parts not included. Portable dryer screens included. Tower dryer screens not included.
	Portable and Tower Dryer Frames and Internal Infrastructure †	5 Years	

GSI further warrants that the portable and tower dryer frame and basket, excluding all auger and auger drive components, shall be free from defects in materials for a period of time beginning on the twelfth (12th) month from the date of purchase and continuing until the sixtieth (60th) month from the date of purchase (extended warranty period). During the extended warranty period, GSI will replace the frame or basket components that prove to be defective under normal conditions of use without charge, excluding the labor, transportation, and/or shipping costs incurred in the performance of this extended warranty.

Conditions and Limitations:

THERE ARE NO WARRANTIES THAT EXTEND BEYOND THE LIMITED WARRANTY DESCRIPTION SET FORTH ABOVE. SPECIFICALLY, GSI MAKES NO FURTHER WARRANTY OF ANY KIND, EXPRESS OR IMPLIED, INCLUDING, WITHOUT LIMITATION, WARRANTIES OF MERCHANTABILITY OR FITNESS FOR A PARTICULAR PURPOSE OR USE IN CONNECTION WITH: (I) PRODUCT MANUFACTURED OR SOLD BY GSI OR (II) ANY ADVICE, INSTRUCTION, RECOMMENDATION OR SUGGESTION PROVIDED BY AN AGENT, REPRESENTATIVE OR EMPLOYEE OF GSI REGARDING OR RELATED TO THE CONFIGURATION, INSTALLATION, LAYOUT, SUITABILITY FOR A PARTICULAR PURPOSE, OR DESIGN OF SUCH PRODUCTS.

GSI shall not be liable for any direct, indirect, incidental or consequential damages, including, without limitation, loss of anticipated profits or benefits. The sole and exclusive remedy is set forth in the Limited Warranty, which shall not exceed the amount paid for the product purchased. This warranty is not transferable and applies only to the original end-user. GSI shall have no obligation or responsibility for any representations or warranties made by or on behalf of any dealer, agent or distributor.

GSI assumes no responsibility for claims resulting from construction defects or unauthorized modifications to products which it manufactured. Modifications to products not specifically delineated in the manual accompanying the equipment at initial sale will void the Limited Warranty.

This Limited Warranty shall not extend to products or parts which have been damaged by negligent use, misuse, alteration, accident or which have been improperly/inadequately maintained. This Limited Warranty extends solely to products manufactured by GSI.

Prior to installation, the end-user has the responsibility to comply with federal, state and local codes which apply to the location and installation of products manufactured or sold by GSI.

This equipment shall be installed in accordance with the current installation codes and applicable regulations, which should be carefully followed in all cases. Authorities having jurisdiction should be consulted before installations are made.



**1004 E. Illinois St.
Assumption, IL 62510-0020
Phone: 1-217-226-4421
Fax: 1-217-226-4420
www.gsiag.com**



GSI is a worldwide brand of AGCO Corporation.