

CE Compliant Custom Auger and Roof Auger

Assembly and Operation Manual -
Original Instructions

PNEG-1445CE

Version: 2.0

Date: 12-22-15



PNEG-1445CE



**CE Declaration of Incorporation
MACHINERY DIRECTIVE
2006/42/EC**

1004 East Illinois Street, Assumption, IL, 62510, USA +1 217 226 4429

The GSI Group declares that the machine, parts or equipment.

GSI Custom and Roof Auger Systems for Fixed, Non-Mobile Applications Only

Models/Parts

- 6" Diameter custom and roof
- 8" Diameter custom and roof
- 10" Diameter custom and roof
- 12" Diameter custom only

Excluding

- Electrical controls
- Electric motors
- GK4395 6" Intake Guard
- GK4394 8" Intake Guard
- GK4393 10" Intake Guard
- GK4614 12" Intake Guard

Required Elements:

OUTLET PROTECTION

- 6" Outlet spouts GK7173, GK7181 or GK7177
- 8" Outlet spouts GK7174, GK7182 or GK7178
- 10" Outlet spouts GK7175, GK7183 or GK7179
- 12" Outlet spouts GK7176, GK7184 or GK7180
- Each of the above supplied and fitted with minimum 850 mm long rigid steel grain tube.

INLET PROTECTION

- 6" Inlet hoppers GK3993 or GK3995
- 8" Inlet hoppers GK4007 or GK3996
- 10" Inlet hoppers GK4127 or GK3994
- 12" Inlet hoppers GK4008 or GK4128
- Other model inlet hoppers may only be used where direct coupled to incoming conveying equipment, fully enclosing the auger flights.



**CE Declaration of Incorporation
MACHINERY DIRECTIVE
2006/42/EC**

1004 East Illinois Street, Assumption, IL, 62510, USA +1 217 226 4429

Meet the following clauses of the Essential Requirements of the Machinery Directive 2006/42/EC

- 1.1.2 and sub-clauses Principles of safety integration
- 1.3.1 Risk of loss of stability
- 1.3.2 Risk of break-up during operation
- 1.3.7 Risk related to moving parts
- 1.3.8 Choice of protection against risks arising from moving parts
 - 1.3.8.1 Moving transmission parts
 - 1.3.8.2 Moving parts involved in the process
- 1.3.9 Risks of uncontrolled movements
- 1.4 Required Characteristics of Guards and Protective Devices
 - 1.4.1 General requirements
 - 1.4.2. Special requirements for guards
 - 1.4.2.1 Fixed guards
- 1.5.4 Errors of fitting
- 1.5.5 Extreme temperatures
- 1.5.6 Fire
- 1.5.7 Explosion
- 1.5.8 Noise
- 1.5.9 Vibrations
- 1.5.13 Emissions of hazardous materials and substances
- 1.6 Maintenance
 - 1.6.1 Machinery maintenance
 - 1.6.4 Operator intervention
- 1.7 Information
 - 1.7.1 Information and warnings on the machinery
 - 1.7.1.1 Information and information devices
 - 1.7.2 Warning of residual risks
 - 1.7.4 Instructions
 - 1.7.4.1 General principles for the drafting of instructions
 - 1.7.4.2 Contents of the instructions but not inclusive of sub-clause (u)
 - 1.7.4.3 Sales literature

This declaration applies only to the above machines and does not imply conformity by any other items of equipment fitted to or connected with the above machines.

The equipment above must not be put into service until the machinery into which it is to be incorporated has been declared in conformity with the provisions of all relevant Directives, nor until these components have been assembled in the manner recommended in the attached manufacturers instructions.

Equipment must be installed in accordance with the attached manual PNEG-1445-CE.

Signed :

Roof Auger Specifications

Auger Length	150 mm (6") Roof Auger	200 mm (8") Roof Auger	250 mm (10") Roof Auger
3.35 m (11')	GRA6111A	GRA8111A	GRA10111A
4.88 m (16')	GRA6161A	GRA8161A	GRA10161A
6.40 m (21')	GRS6211A	GRA8211A	GRA10211A

6" Roof Auger	8" Roof Auger	10" Roof Auger
16 Gauge Housing	14 Gauge Housing	12 Gauge Housing
1-1/4" Flight Shaft	1.90" Flight Shaft	2-3/8" Flight Shaft
10 Gauge Flight	0.188" Flight	0.188" Flight
12" O.D., 2 Belt, 1" Bore Pulley	12" O.D., 2 Belt, 1-1/4" Bore Pulley	15" O.D., 2 Belt, 1-1/2" Bore Pulley (Three (3) Belt Pulley for 41' Model.)
Available Lengths: 11', 16', 21'	Available Lengths: 11', 16', 21'	Available Lengths: 11', 16' (with Internal Bearing), 21' (with Internal Bearing)
Available Extensions: 5', 10', 15', 20'	Available Extensions: 5', 10', 15', 20'	Available Extensions: 5', 10', 15', 20'
Motor Power Requirements: 11' (1-1.5 HP), 16' (1-1.5 HP) and 21' (1.5-2 HP)	Motor Power Requirements: 11' (1.5-2 HP), 16' (1.5-2 HP) and 21' (2-3 HP)	Motor Power Requirements: 11' (2-3 HP), 16' (2-3 HP) and 21' (3-5 HP)
Hopper tail piece with lid, three (3) mounting brackets and 90° spout included. <u>Required</u> 850 mm 6" rigid steel grain tube.	Hopper tail piece with lid, three (3) mounting brackets and 90° spout included. <u>Required</u> 850 mm 8" rigid steel grain tube.	Hopper tail piece with lid, three (3) mounting brackets and 90° spout included. <u>Required</u> 850 mm 10" rigid steel grain tube.

Contents

Chapter 1 Introduction	6
Chapter 2 Safety	7
Safety Guidelines	7
Cautionary Symbols Definitions	8
Safety Cautions	9
Safety Sign-Off Sheet	12
Minimum Auger Safety Requirements	13
Electrical Safety Equipment	17
Chapter 3 Safety Decals	18
International Decals	18
Chapter 4 Assembly	21
Motor Mount Installation Instructions for all 6", 8", 10" and 12" Custom Augers	21
Assembling the Flight Extension for all 6", 8", 10" and 12" Custom Augers	32
Assembling the Inlet Hopper with Bearings for all 6", 8", 10" and 12" Custom Augers	42
Attaching Discharge Spout and Grain Tube	45
Outlet Cutting Guidelines	47
Enclosed Slide Gates with Rack and Pinion Control	48
Basic Inlet Hoppers	49
Spouting, Fittings and Truss Kits	49
Sample Custom Auger Configurations	50
Use as a Roof Auger - Installing the Auger Stands	51
Chapter 5 Electric Drive Motors	54
Horsepower Information for Electric Motors	54
Chapter 6 Start-Up	55
Start-Up and Break-In	55
Chapter 7 Operation/Maintenance	56
Operate the Auger	56
Maintain the Auger	56
Chapter 8 Shut Down	57
Normal Shut Down	57
Emergency Shut Down	57
Lock Out	57
Storage Preparation	57
Chapter 9 Parts List	59
6" Custom Auger Parts	60
8" Custom Auger Parts	62
8" Internal Bearing Parts	64
10" Custom Auger Parts	66
10" Internal Bearing Parts	68
12" Custom Auger Parts	70
12" Internal Bearing Parts	72
6" Roof Augers Parts	74
8" Roof Augers Parts	76
10" Roof Augers Parts	78
Chapter 10 Troubleshooting	80
Chapter 11 Warranty	81

1. Introduction

READ THIS MANUAL carefully to learn how to properly use and install equipment. Failure to do so could result in personal injury or equipment damage.

INSPECT the shipment immediately upon arrival. The customer is responsible for ensuring that all quantities are correct. The customer should report and note any damage or shortage on the bill of lading to justify their claim to the transport company.

THIS MANUAL SHOULD BE CONSIDERED a permanent part of your equipment and should be easily accessible when needed.

This warranty provides you the assurance that the company will back its products when defects appear within the warranty period. In some circumstances, the company also provides field improvements, often without charge to the customer, even if the product is out of warranty. Should the equipment be abused, or modified to change its performance beyond the factory specifications, the warranty will become void and field improvements may be denied.

Safety Guidelines

Safety guidelines are general-to-specific safety rules that must be followed at all times. This manual is written to help you understand safe operating procedures and problems that can be encountered by the operator and other personnel when using this equipment. Save these safety guidelines for future reference.

As owner or operator, you are responsible for understanding the requirements, hazards, and precautions that exist and to inform others as required. Unqualified persons must stay out of the work area at all times.

Alterations must not be made to the equipment. Alterations can produce dangerous situations resulting in **SERIOUS INJURY** or **DEATH**.

This equipment must be installed in accordance with the current installation codes and applicable regulations, which must be carefully followed in all cases. Authorities having jurisdiction must be consulted before installations are made.

When necessary, you must consider the installation location relative to electrical, fuel and water utilities.

Personnel operating or working around equipment must read this manual. This manual must be delivered with equipment to its owner. Failure to read this manual and its safety instructions is a misuse of the equipment.

ST-0001-3

Cautionary Symbols Definitions

Cautionary symbols appear in this manual and on product decals. The symbols alert the user of potential safety hazards, prohibited activities and mandatory actions. To help you recognize this information, we use the symbols that are defined below.



This symbol indicates an imminently hazardous situation which, if not avoided, **will result in serious injury or death.**



This symbol indicates a potentially hazardous situation which, if not avoided, **can result in serious injury or death.**



This symbol indicates a potentially hazardous situation which, if not avoided, **can result in minor or moderate injury.**



This symbol is used to address practices not related to personal injury.



This symbol indicates a general hazard.



This symbol indicates a prohibited activity.

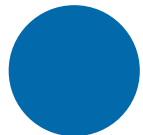

This symbol indicates a mandatory action.

ST-0005-2

Safety Cautions

Use Personal Protective Equipment

- Use appropriate personal protective equipment:

Eye Protection



Respiratory Protection



Foot Protection



Hearing Protection



Head Protection



Fall Protection



Hand Protection



- Wear clothing appropriate to the job.
- Remove all jewelry.
- Tie long hair up and back.

ST-0004-1

Follow Safety Instructions

- Carefully read all safety messages in this manual and safety signs on your machine. Keep signs in good condition. Replace missing or damaged safety signs. Be sure new equipment components and repair parts include the current safety signs. Replacement safety signs are available from the manufacturer.
- Learn how to operate the machine and how to use controls properly. Do not let anyone operate without instruction.
- If you do not understand any part of this manual or need assistance, contact your dealer.



ST-0002-1

2. Safety

Maintain Equipment and Work Area

- Understand service procedures before doing work. Keep area clean and dry.
- Never service equipment while it is operating. Keep hands, feet, and clothing away from moving parts
- Keep your equipment in proper working condition. Replace worn or broken parts immediately.



ST-0003-1

Operate Motor Properly

- All electrical connections must be made in accordance with the National Electric Code (US) or Canadian Electrical Code (CEC). Be sure equipment and bins are properly grounded.
- Lock-out power before resetting motor overloads.
- Do not repetitively stop and start the drive in order to free a plugged condition. Jogging the drive in this manner can damage the equipment and drive components.



ST-0009-2

Rotating Auger Hazard

- Keep clear of rotating augers and moving parts.
- Do not remove or modify guards. Failure to follow these precautions will result in serious injury or death.



ST-0037-1

Stay Clear of Hoisted Equipment

- Always use proper lifting or hoisting equipment when assembling or disassembling equipment.
- Do not walk or stand under hoisted equipment.
- Always use sturdy and stable supports when needed for installation. Not following these safety precautions creates the risk of falling equipment, which could crush personnel and cause serious injury or death.



ST-0047-1

Stay Clear of Rotating Parts

- Do not enter the bin while the equipment is in operation.
- Entanglement in rotating augers will cause serious injury or death.
- Keep all shields and covers in place at all times.
- Lock-out power source before making adjustments, cleaning, or maintaining equipment.



ST-0008-1

Use Unload Equipment Properly

- Do not operate this equipment alone. Make sure someone nearby is aware of the proper shut down sequence in the event of an emergency.
- Do not allow any person intoxicated or under the influence of drugs to operate this equipment. All operators must be adequately rested and prepared to perform all functions of operating the equipment.
- Do not start equipment until all persons are clear of the work area and safety guards are in place.
- Do not allow anyone inside a bin, truck, or wagon which is being unloaded by an auger. Flowing grain can trap and suffocate in seconds.
- Use ample overhead lighting after sunset to light the work area.
- Always use caution to not hit the auger when positioning the load.
- Do not leave equipment operating while unattended.
- Be aware of pinch points, which can trap or catch objects and cause injury.
- Be sure all equipment is locked in position before operating.
- Always lock out all power sources to the equipment when unloading is finished.



ST-0051-1

Minimum Auger Safety Requirements



Incorrect use of augers can be extremely dangerous. Rotating flights and shafts can cause serious injury and kill.

Auger Guards

The following fixed guards must be fitted at all times:

1. Intake guard and hopper, providing all round enclosure of the auger and shaft. (See Figure 2A.)

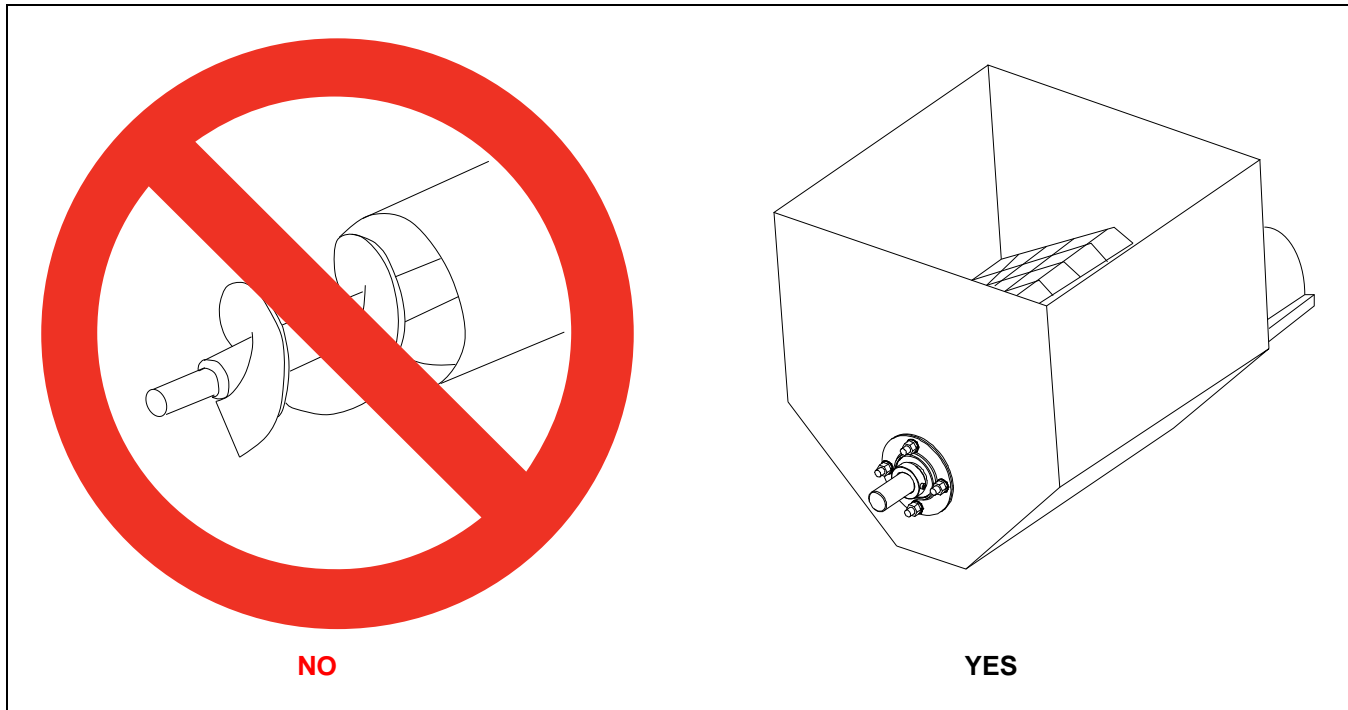

Figure 2A

a. Required Inlet Protection

- 6" Inlet hoppers (GK3993 or GK3995)
- 8" Inlet hoppers (GK4007 or GK3996)
- 10" Inlet hoppers (GK4127 or GK3994)
- 12" Inlet hoppers (GK4008 or GK4128)

b. Other model inlet hoppers may only be used where direct coupled to incoming conveying equipment, thus fully enclosing the auger flights.

c. This includes all intermediate intakes.

2. Outlet guard, comprising discharge spout and minimum 850 mm long solid steel extension tube. (See Figure 2B on Page 14.)

- a. This length of tube is required to reduce the risk of persons reaching the auger flight or shaft.
- b. This includes all intermediate outlets.

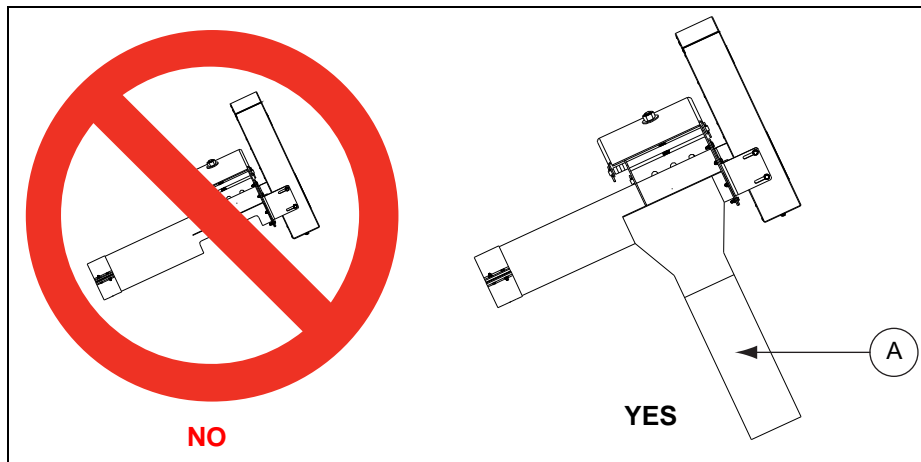

Figure 2B

Ref #	Description
A	Minimum 850 mm Long Tube

c. Required Outlet Protection

- 6" Outlet spouts (GK7173, GK7181 or GK7177)
- 8" Outlet spouts (GK7174, GK7182 or GK7178)
- 10" Outlet spouts (GK7175, GK7183 or GK7179)
- 12" Outlet spouts (GK7176, GK7184 or GK7180)

Each of the above supplied and fitted with minimum 850 mm long rigid steel grain tube.

d. A shorter tube may be used only where the tube is directly connected to other handling equipment. ([See Figure 2C.](#))

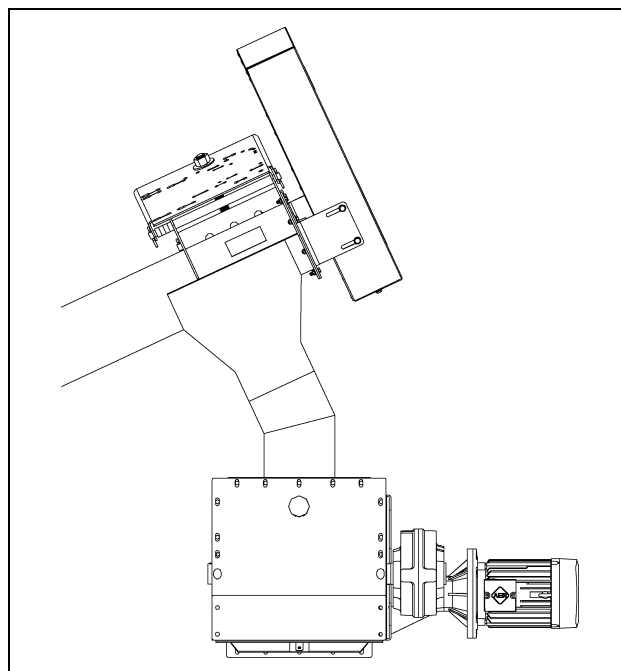

Figure 2C

3. Belt drive and pulley guard

Figure 2D

Correct Use

1. The auger is for conveying whole agricultural seeds and grains ONLY. Any other use is prohibited and may result in injury or equipment damage.
2. Never use the auger with any guards removed.
3. Never approach the inlet or outlet or other moving parts of the auger with hands, feet or any implement unless the power supply to the auger is OFF, TAGGED and LOCKED. (See Figure 2E.)

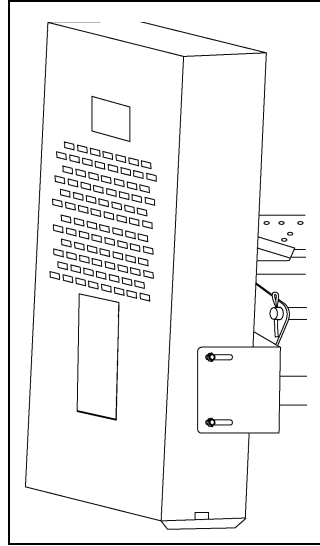

Figure 2E

4. Never leave the auger running un-attended.
5. Always TURN OFF and LOCK the power supply to the auger before leaving it un-attended.
6. Never allow an untrained person less or one less than 18 years old to operate the auger or within the work area defined around the auger.
7. Never allow someone under the influence of alcohol or drugs to operate the equipment.
8. Never modify the auger from it is original specification.

2. Safety

9. Never work alone.
10. Never start equipment until all persons are clear of the work area.
11. Keep hands and feet away from the auger intake and other moving parts.
12. Always think before acting. Never act impulsively around the equipment.
13. Never allow anyone inside a bin, truck or wagon which is being loaded or unloaded. Flowing grain can trap and suffocate in seconds.
14. Use adequate lighting after sunset to light the work area.
15. Keep area around intake free of obstacles such as electrical cords, blocks, etc., that might trip workers.
16. Never drive, stand or walk under the equipment.
17. Use caution not to hit the auger when positioning the load.

Auger Stability

1. The auger must be fixed in position and secured with brackets at all times to prevent tipping or rotation. (See Figure 2F.)

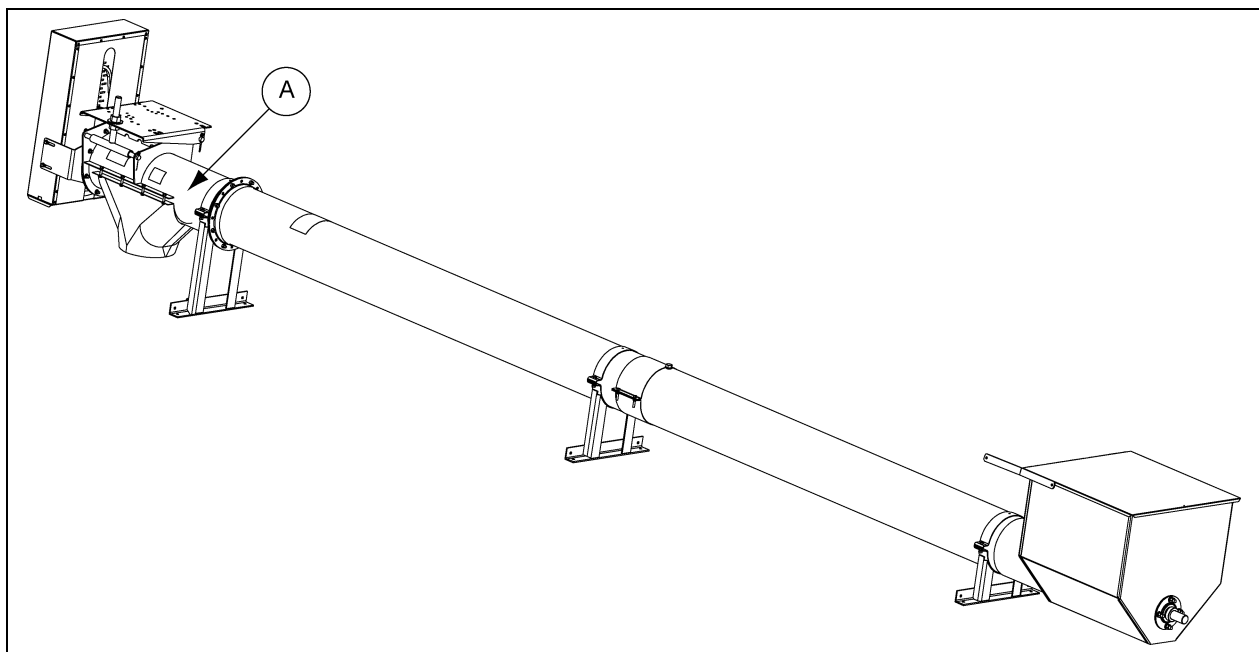

Figure 2F

Ref #	Description
A	Fixing Bracket

2. The drive train and motor makes the auger top heavy. Use mechanical lift equipment when lifting, with one strap attached at the drive end and the other more than half way down the length of the auger.
3. When fitting a roof auger, it is essential that you ensure the bin roof is capable of carrying the weight of the auger, motor and grain. Bear in mind roof loading from augers will be dynamic due normal vibration generated by an auger.

Electrical Safety Equipment

The following items are the minimum required when making electrical connections to the auger:

1. Main electrical disconnect.



- a. Wired to disconnect all electrical power to the auger and other associated equipment.
- b. Lockable.

2. Service disconnect.



- a. Wired to break all electrical power to the auger motor.
- b. Lockable.

3. Emergency stop.



- a. Wired to stop the auger motor (and any other associated equipment) immediately when pressed.
- b. Must remain engaged until manually disengaged.

4. Start/Stop controls.



- a. Recessed start push button labelled 1.
- b. Non-recessed stop push button labelled 0.
- c. Motor starter, short circuit protection and motor overload.
- d. Control must be designed to default to OFF after a power interruption. (Ex: Self maintained relay.)
- e. The auger **MUST NOT** be able to immediately re-start following re-establishment of power.

5. Door interlock.



- a. Recommended where an exposed auger (Ex: sweep auger) is operating inside a grain bin, store, dryer or other enclosed space.
- b. Door interlock to be wired to stop the auger (and any other equipment) immediately the door is opened.
- c. Auger **MUST NOT** be able to re-start immediately the door is re-closed.
- d. This does not override the need to LOCK OUT electrical power before entering the bin.

6. All electrical installation and design must be carried out by a qualified electrical engineer and in accordance with EU Directives and standards and in accordance with local laws and codes.

7. The electrical supply must include a properly designed protective earth system (PE).

8. The motor must be connected to protective earth at the terminal provided.

9. The control system must include short circuit protection.

10. It is recommended to provide earth leakage protection, such as Residual Current Device (RCD) or Residual Current Circuit Breaker (RCCB) to provide automatic disconnection from the power in the event of a fault.

3. Safety Decals

Below are the safety warning decals that should be fitted to the auger. These warn of residual risks and required safety measures and must remain intact, legible and undamaged for the life of the machine. If any decals have become damaged or unreadable, please contact GSI or your dealer for free replacements.

International Decals

International, translated versions of the decals fitted to the equipment are available as part of the Language Pack that was supplied with the product. If you need further copies or a different language, please contact GSI or your dealer.

The international decals have been designed to be placed directly over the USA standard versions. Normally these will be factory fitted, but if you need to change them, please refer to the decal cross reference sheet, provided with the Language Pack and the decal locations given in the user's manual.

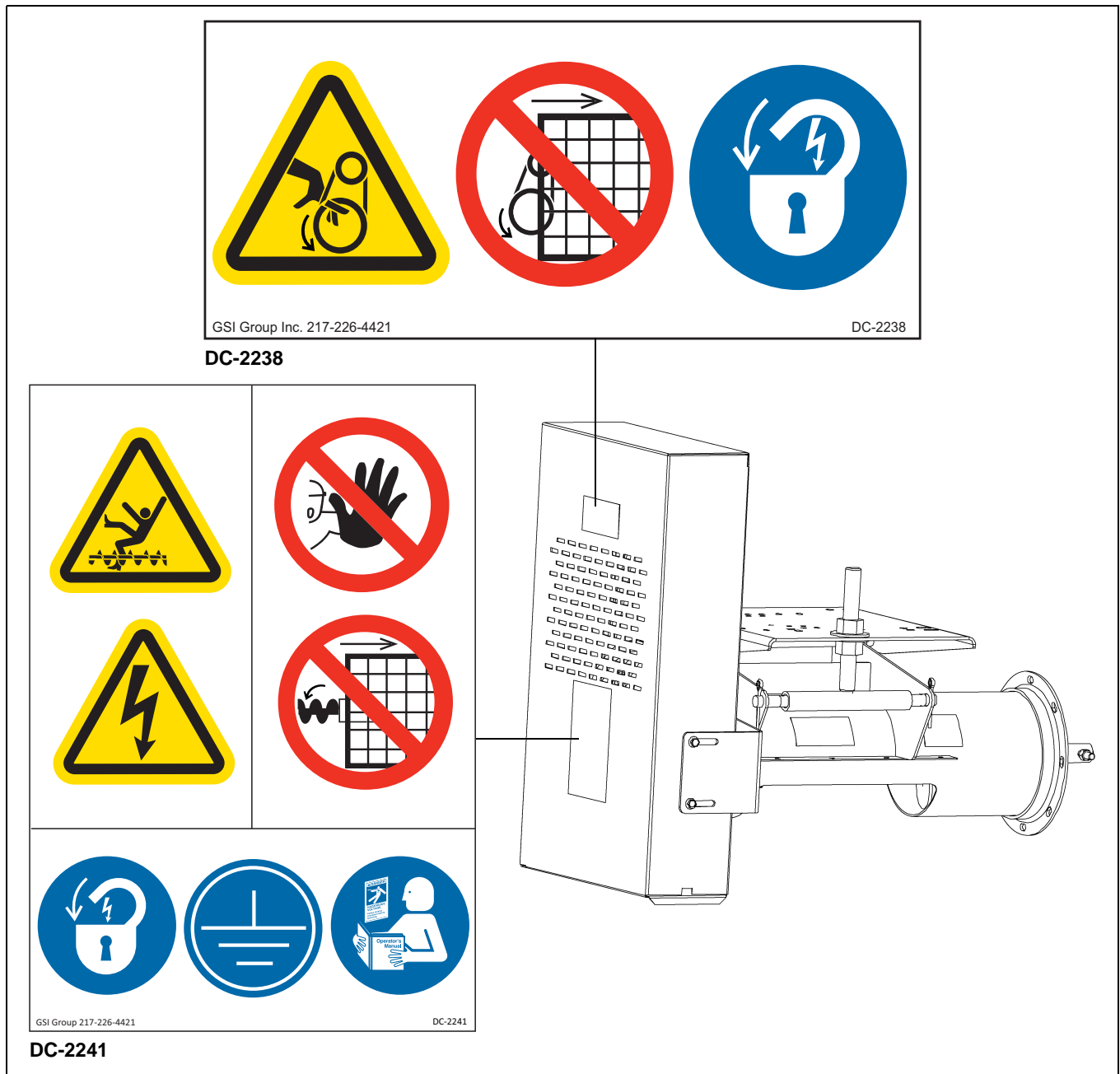

Figure 3A

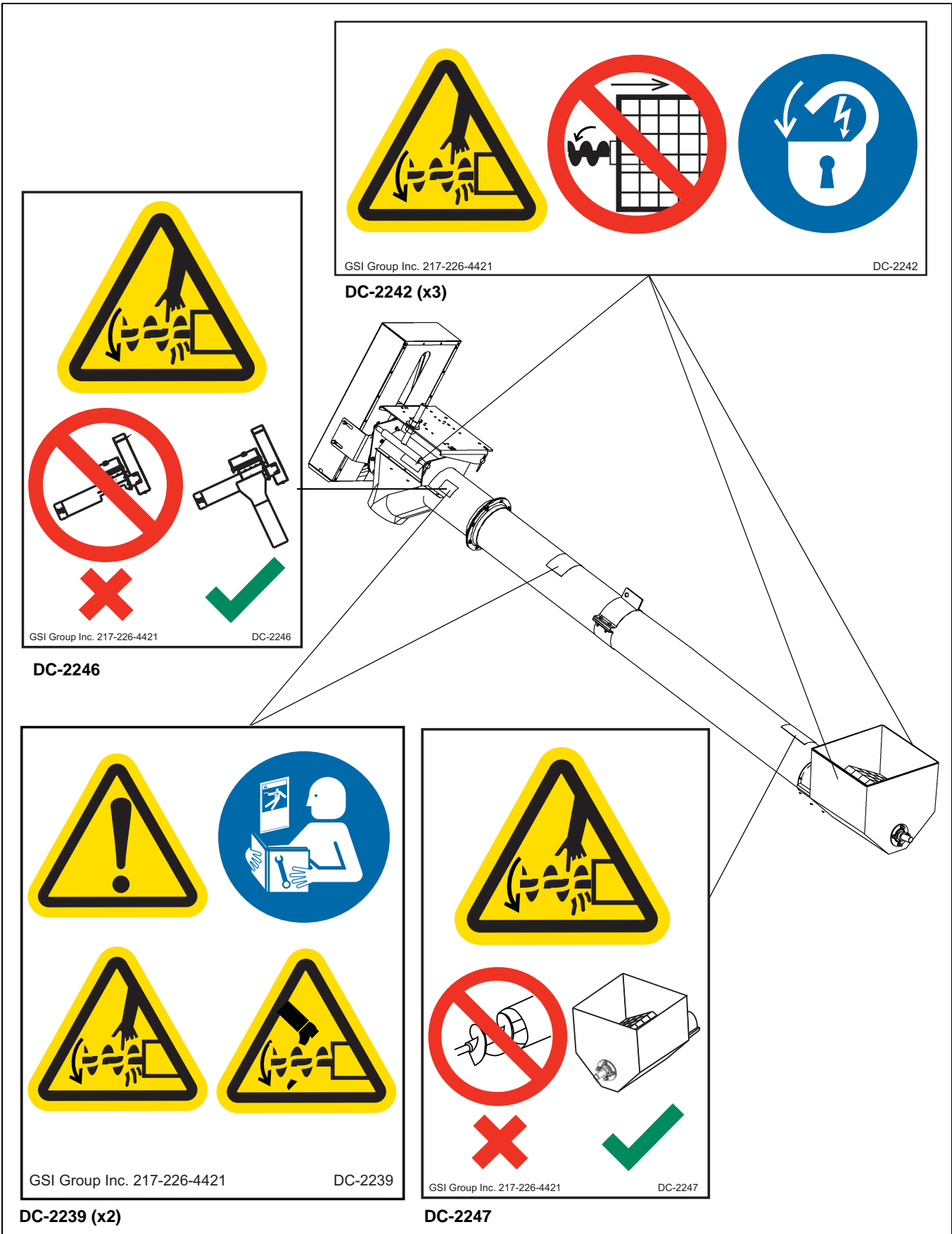

Figure 3B

3. Safety Decals

DC-2244 should be fitted to all bins where augers are installed. This should be located in clear view adjacent to all personnel entry points on the bin.

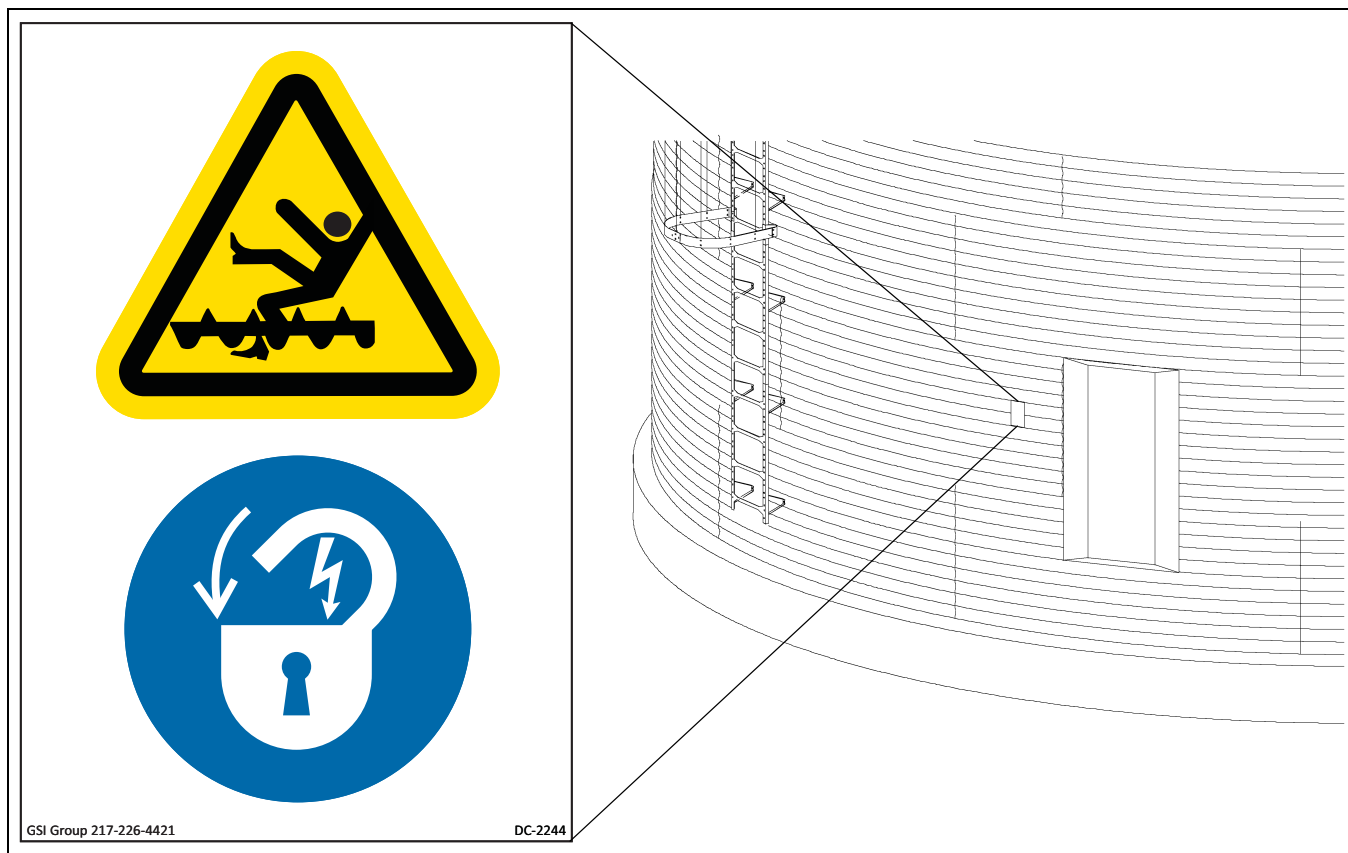

Figure 3C

Motor Mount Installation Instructions for all 6", 8", 10" and 12" Custom Augers

Installing Drive Shaft

1. Insert the drive shaft (A) into the opposite end of flight with keyway (B) facing outward. Align the holes in the shaft and secure with grade 8 bolts (C) and stover nuts (D). (See Chart below and Figure 4A.)

Flight Hardware	
6"	3/8"-16 x 2" Grade 8 Hex Bolts
8"	7/16"-14 x 3" Grade 8 Hex Bolts
10"	1/2"-13 x 3-1/2" Grade 8 Hex Bolts
12"	5/8"-11 x 4" Grade 8 Hex Bolts

(See Chart above for bolt sizes.)

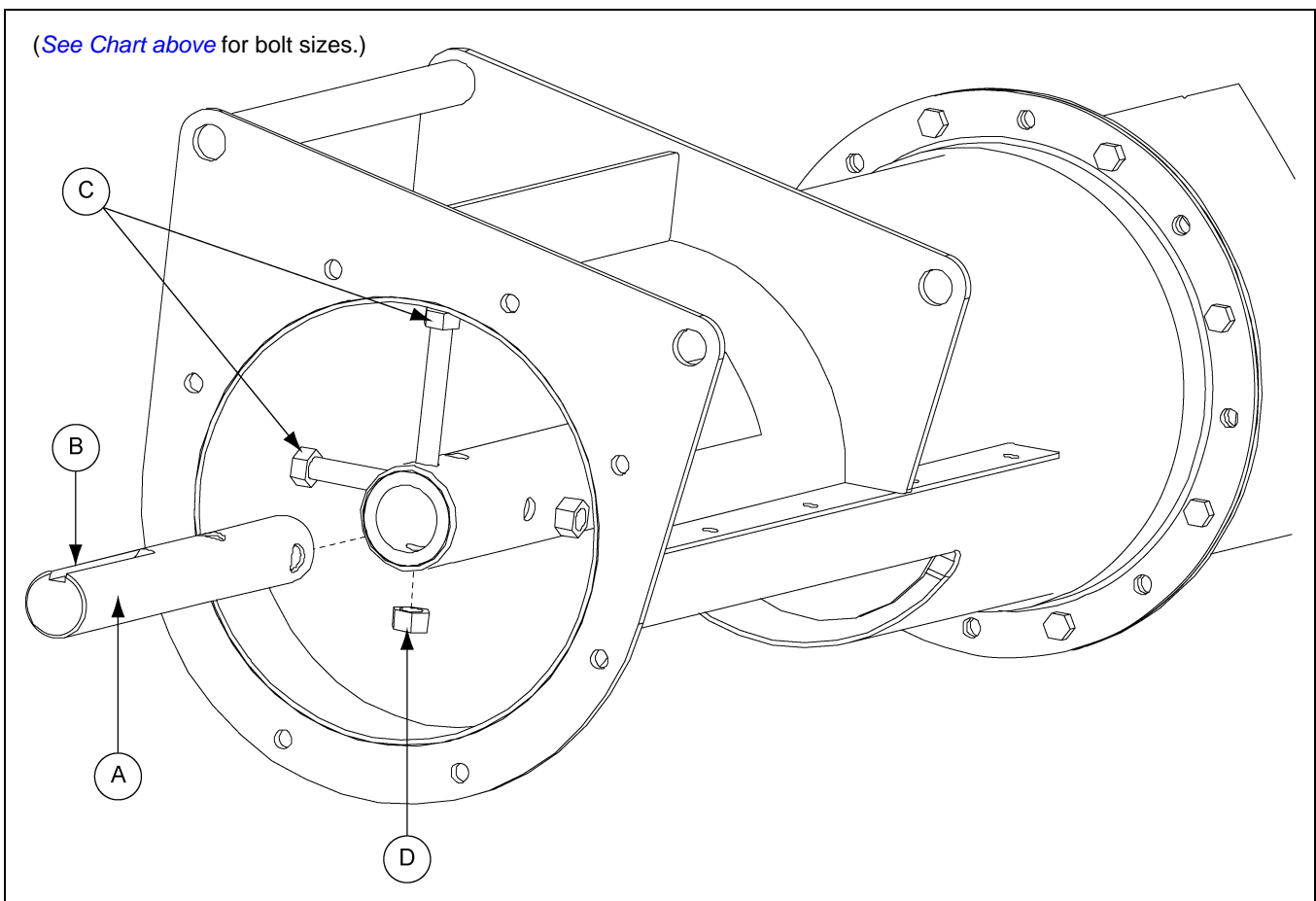

Figure 4A

Ref #	Description
A	Drive Shaft
B	Keyway
C	Bolts
D	Stover Nut

4. Assembly

Mounting Bearing to Bearing Plate

1. Align bolt holes on bearing flange (A) with bolt holes on bearing plate (B).
2. Secure bearing to bearing plate (B) using appropriate bolts (C), lock washers (D) and nuts (E).
(See Chart below and Figure 4B.)

Bearing Bolts	
6"	7/16"-14 x 1-1/2" Bolt
8" and 10"	1/2"-13 x 1-1/2" Bolt
12"	5/8"-11 x 2" Bolt

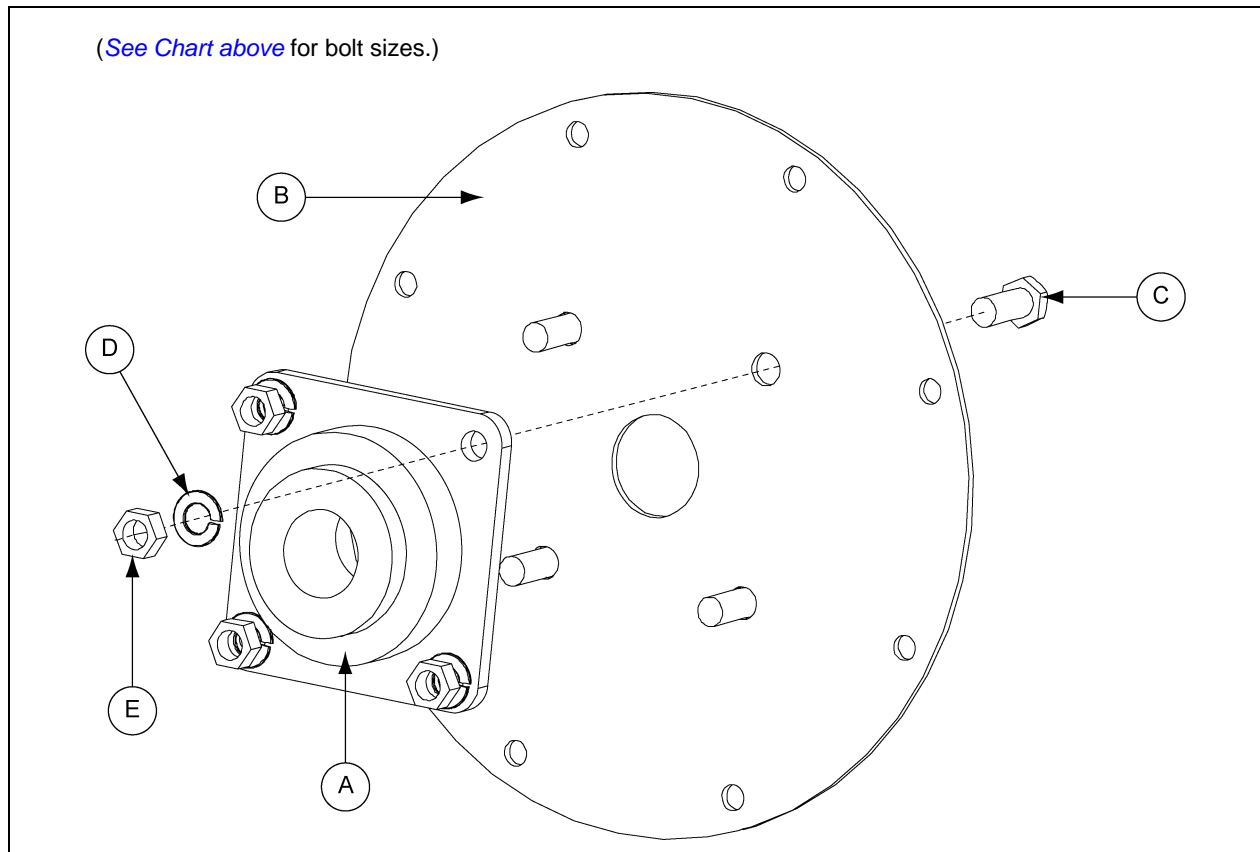

Figure 4B

Ref #	Description
A	Bearing Flange
B	Bearing Plate
C	Bolt
D	Lock Washer
E	Nut

Installing Bearing Plate onto Tube

1. Align bearing with drive shaft (B) and slip shaft through bearing.
2. Rotate plate until bolt holes in tube flange and plate align. Secure with appropriate bolts (C) and serrated flange nuts (D). *(See Chart below.)*
3. Only secure with UPPER and LOWER four (4) bolts. *(See Figure 4C.)* The other four (4) bolts will be installed later with the belt guard mounting brackets. *(See Chart below.)*

NOTE: *On the 10" and 12" systems, use the four (4) 3/8"-16 x 1" bolts in this step, the longer bolts will be used to attach the belt guard mounting brackets in a future step.*

Bearing Plate Bolts	
6" and 8"	5/16"-18 x 1" Bolt
10" and 12"	3/8"-16 x 1" Bolt

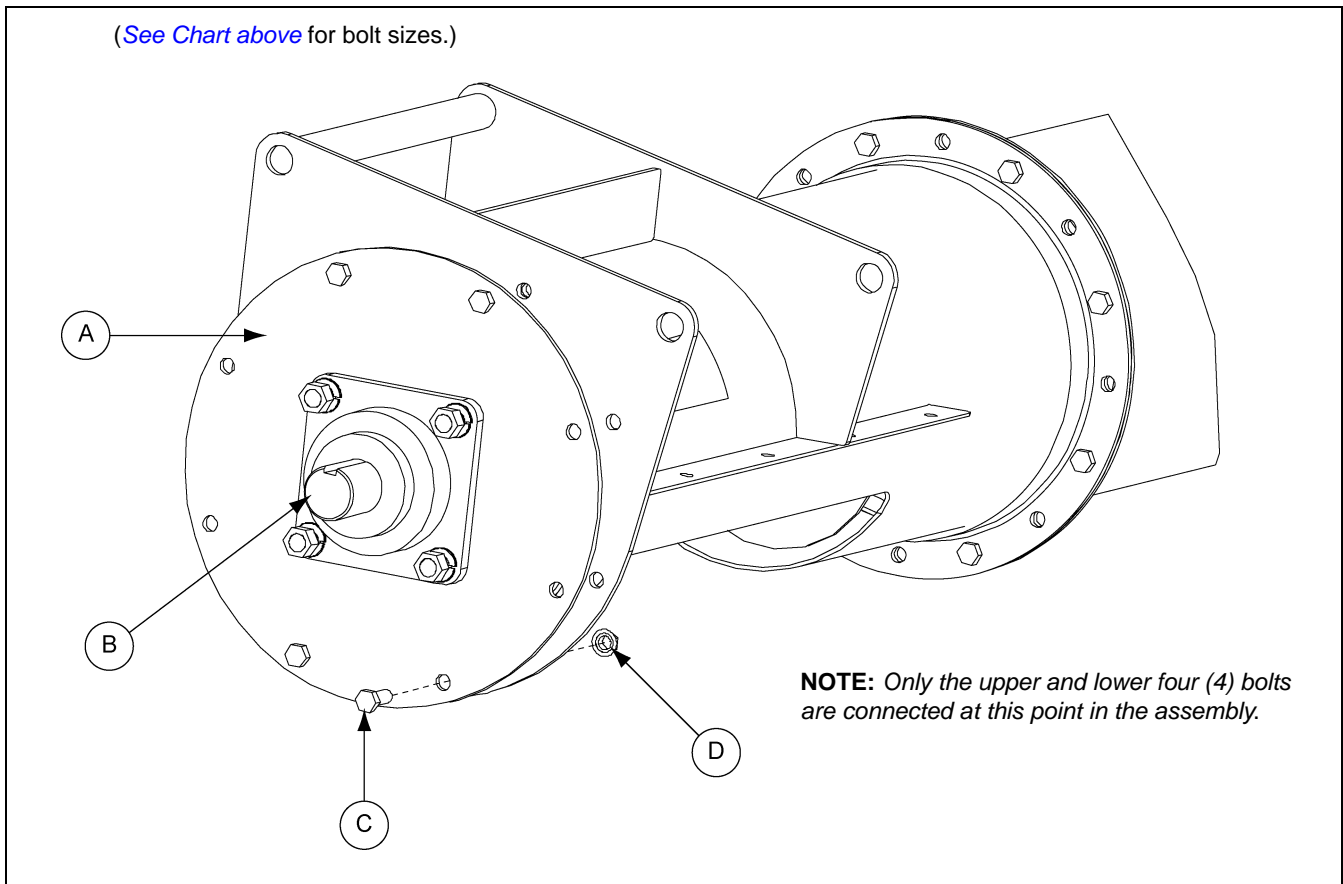

Figure 4C

Ref #	Description
A	Bearing Plate
B	Drive Shaft
C	Bolt
D	Serrated Flange Nut

4. Assembly

Installing the Motor Mount Adjuster

1. Place motor mount adjuster (A) between the back plate (B) and head plate (C) on the discharge tube.
2. Insert pivot rod (D) through the tube plates and motor mount adjuster. Secure in place with two (2) 3/16" x 2" cotter pins (E). (See Figure 4D.)

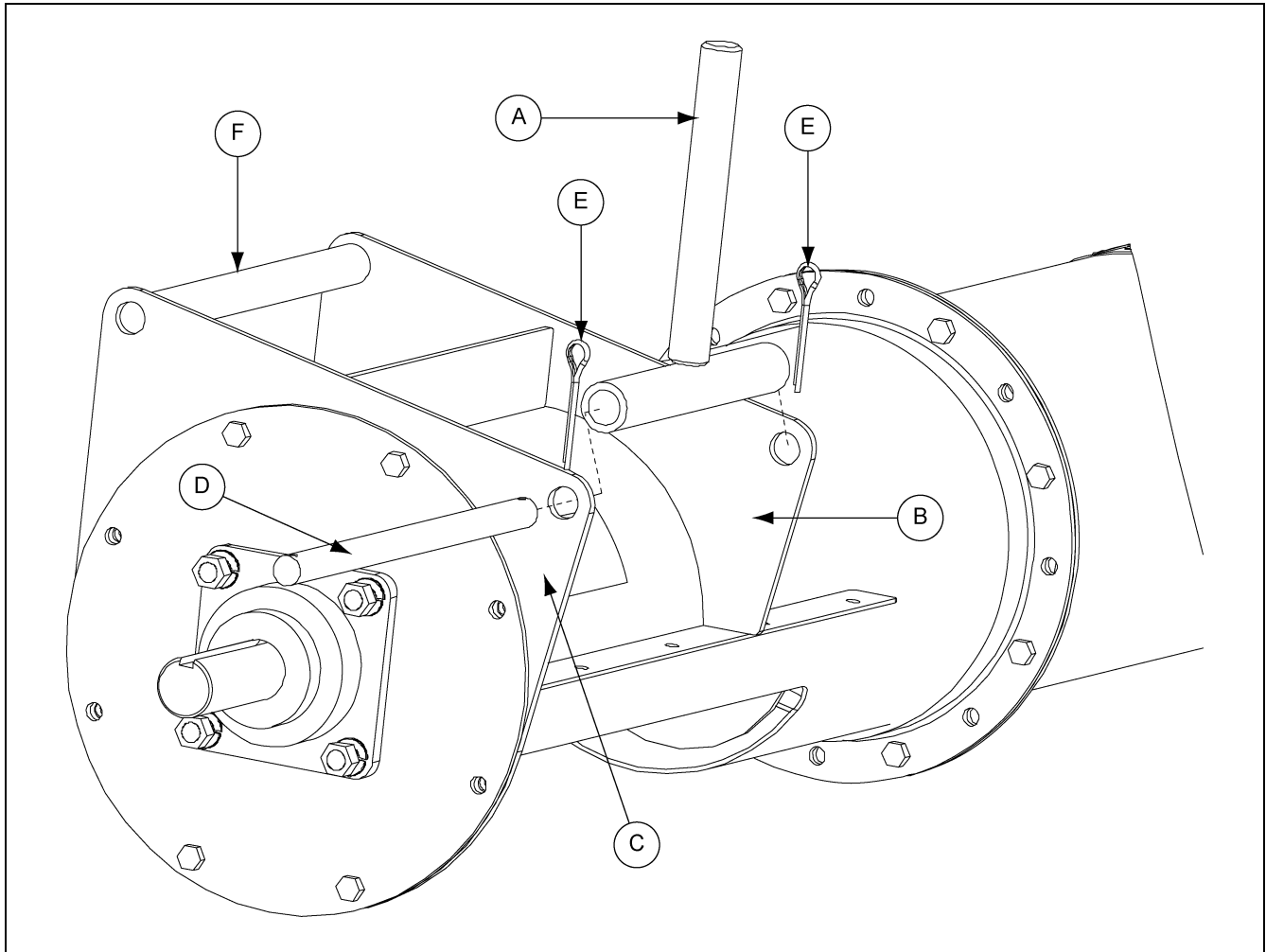

Figure 4D

Ref #	Description
A	Motor Mount Adjuster
B	Back Plate
C	Head Plate
D	Pivot Rod
E	Cotter Pins
F	Pivot Tube

Installing the Motor Mount Plate

1. Secure one of the motor mount adjustment nuts (A) and one the motor mount adjustment washers (B) approximately 3/4 of the way down the motor mount adjuster's threaded shaft (C).
2. Once the nut and washer is secure, slip the motor mount plate (D) over the adjuster and align the pivot holes (E) with the pivot tube (F). (See Figure 4E.)
3. Slide the motor mount pivot rod (G) through the pivot tube (F) on the discharge tube.

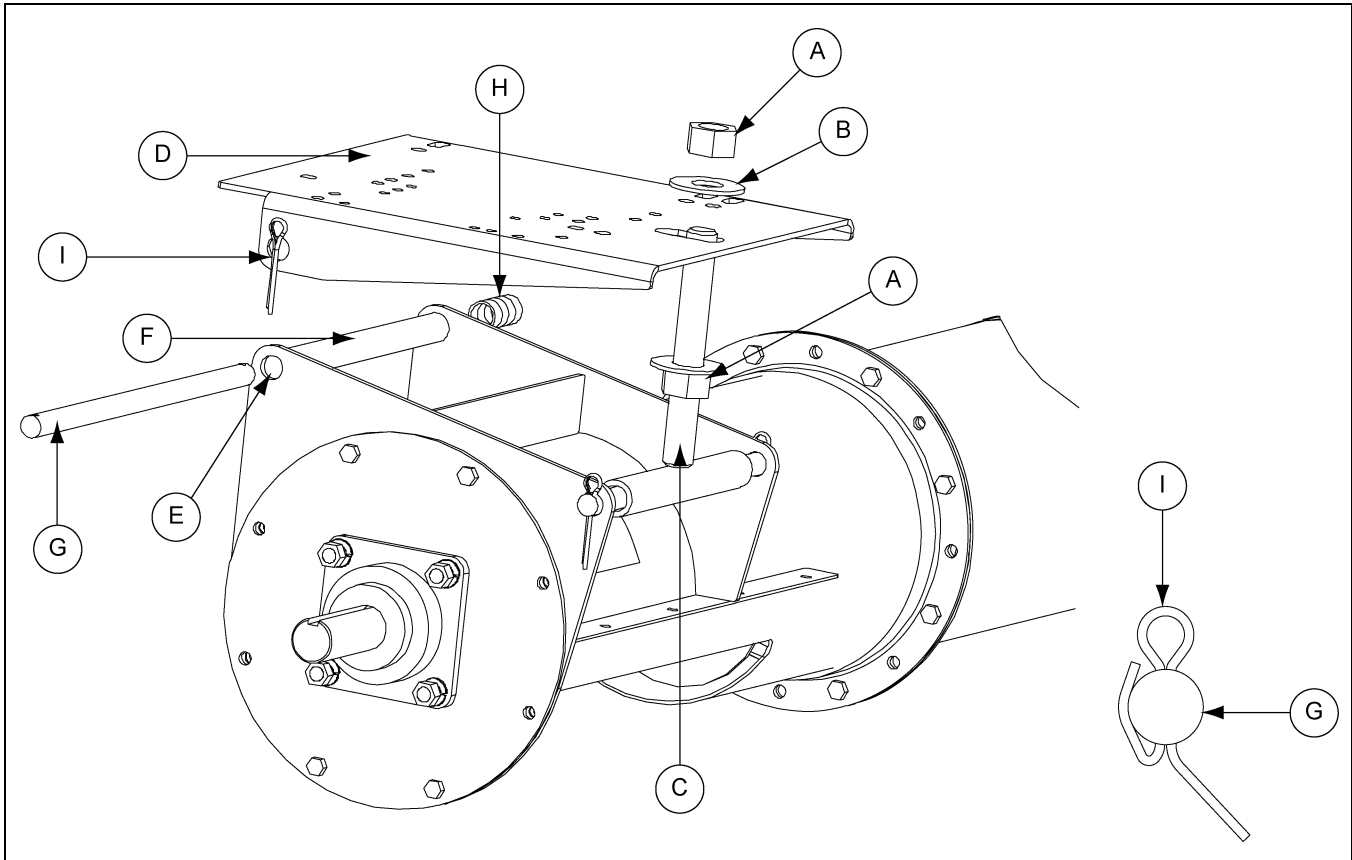

Figure 4E

Ref #	Description
A	Motor Mount Adjustment Nut
B	Motor Mount Adjustment Washer
C	Motor Mount Adjustment Shaft
D	Motor Mount Plate
E	Pivot Hole
F	Pivot Tube
G	Motor Mount Pivot Rod
H	Spacer
I	Cotter Pin

4. Assembly

Installing the Motor Mount Plate (Continued)

4. When the pivot rod (A) begins to extend through the pivot tube install the spacers (B), BETWEEN the back plate and the inner face of the motor mount plate (C). (See Figure 4F.)

NOTE: The number of spacers will vary between each size of unloader.

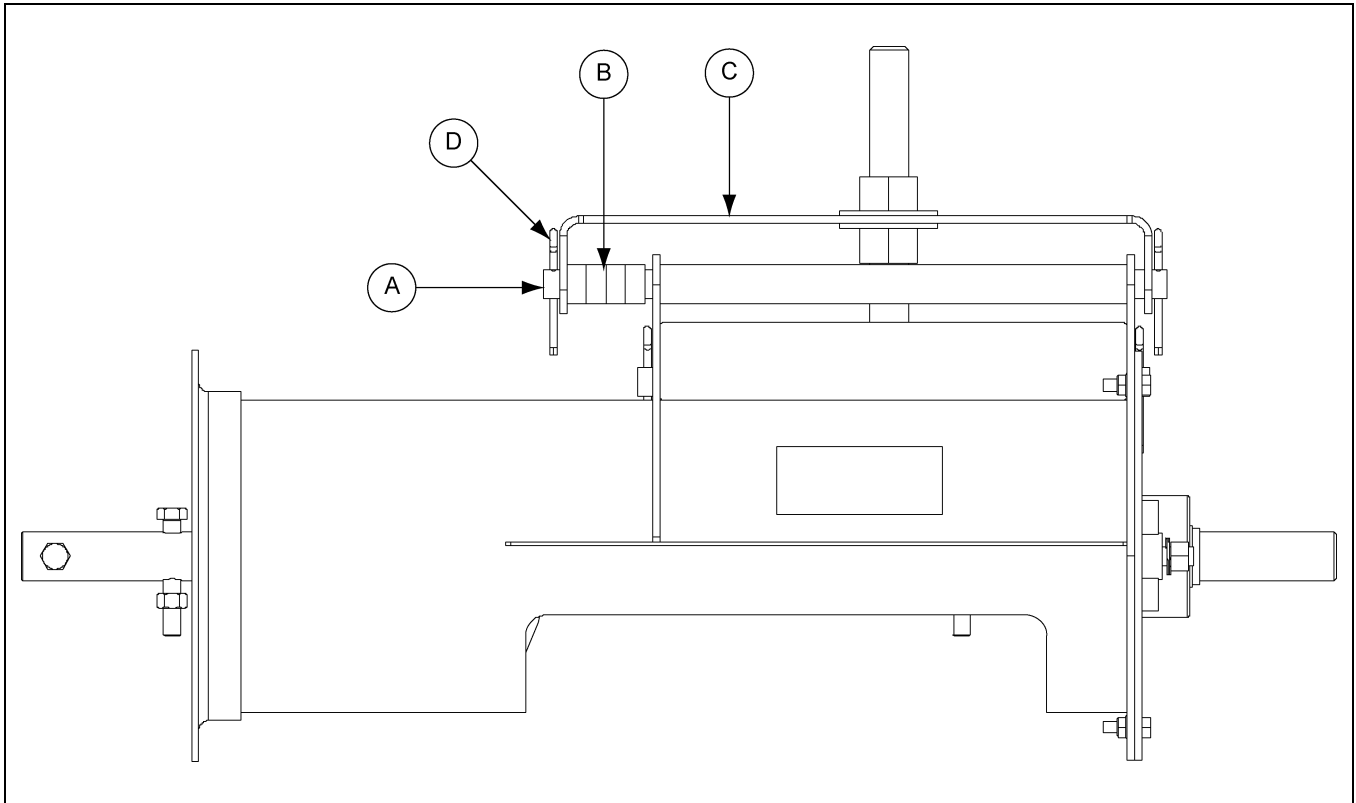

Figure 4F

Ref #	Description
A	Pivot Rod
B	Spacer
C	Motor Mount Plate
D	Cotter Pin

Installing the Belt Guard Brackets

1. Align the holes on the bearing plate (A) with the slots on the belt guard mounting brackets (B).
2. Secure the brackets with proper bolts (C), flat washers (D) and serrated flange nuts (F).
(See Chart below and Figure 4G.)

NOTE: DO NOT tighten the bolts completely. The brackets will need to be rotated to align the slot in the belt guard with the shafts on the motor and flight.

Belt Guard Bracket Bolts	
6" and 8"	5/16"-18 x 1" Bolt
10" and 12"	3/8"-16 x 1-1/4" Bolt

(See Chart above for bolt sizes.)

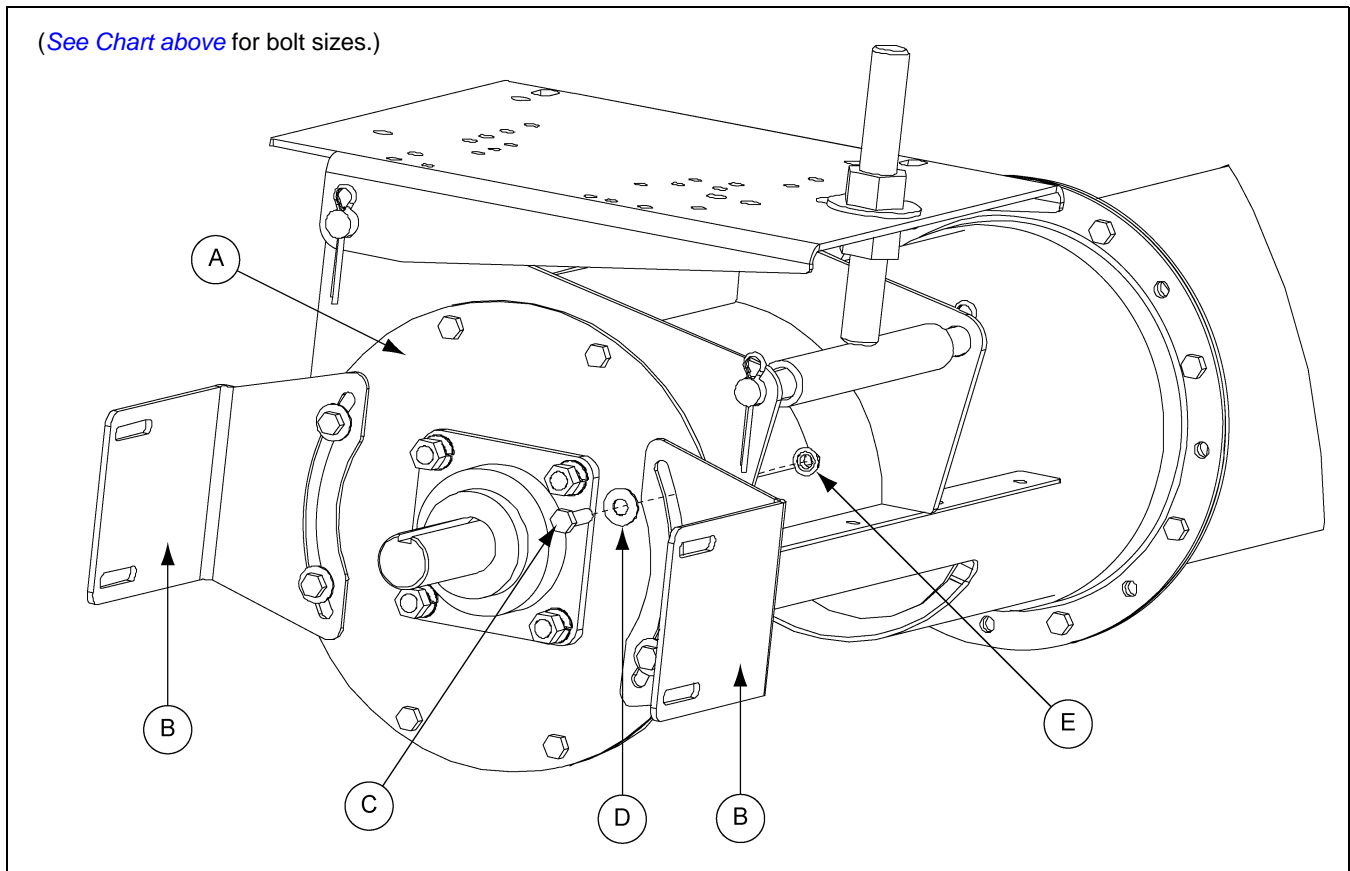

Figure 4G

Ref #	Description
A	Bearing Plate
B	Belt Guard Mounting Brackets
C	Bolt
D	Flat Washer
E	Serrated Flange Nut

4. Assembly

Installing the Lock Collar

1. Slide the lock collar (A) over the drive shaft (B), positioning it against the bearing. Do not tighten the lock collar at this time as it will be tightened later in the assembly. (See Figure 4H.)

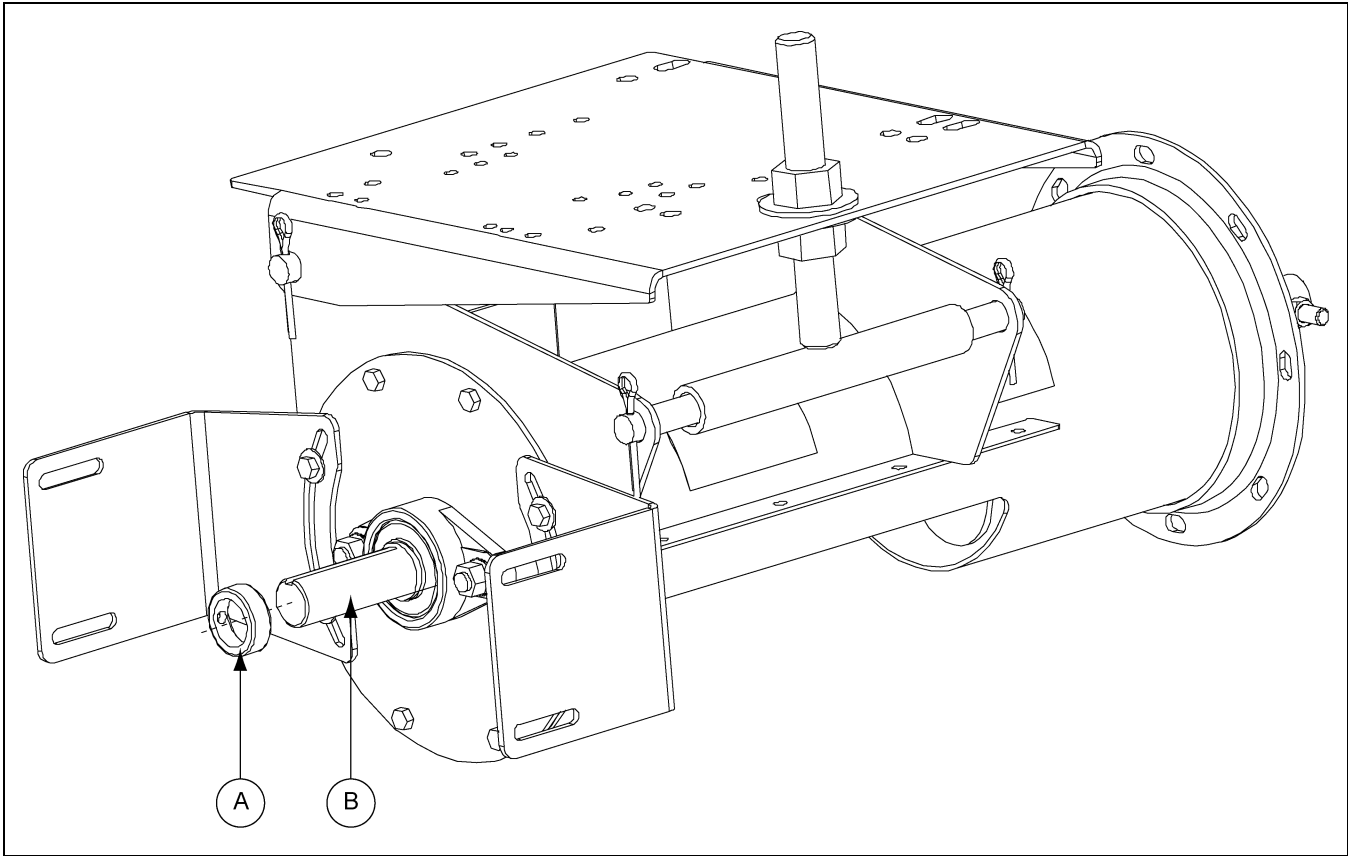

Figure 4H

Ref #	Description
A	Lock Collar
B	Drive Shaft

Installing the Pulley

1. Place and position the key (A) into the keyway located on the drive shaft (B).
2. Place the pulley (C) onto the drive shaft (B) with the set screw (D) side of the pulley facing away from the bearing plate (E). Position the pulley so that it is as close to the lock collar as possible, but not touching it.
3. Once the pulley (C) is appropriately positioned, tighten the set screw (D) with a hex head wrench to secure it to the drive shaft (B). (See Figure 4I.)

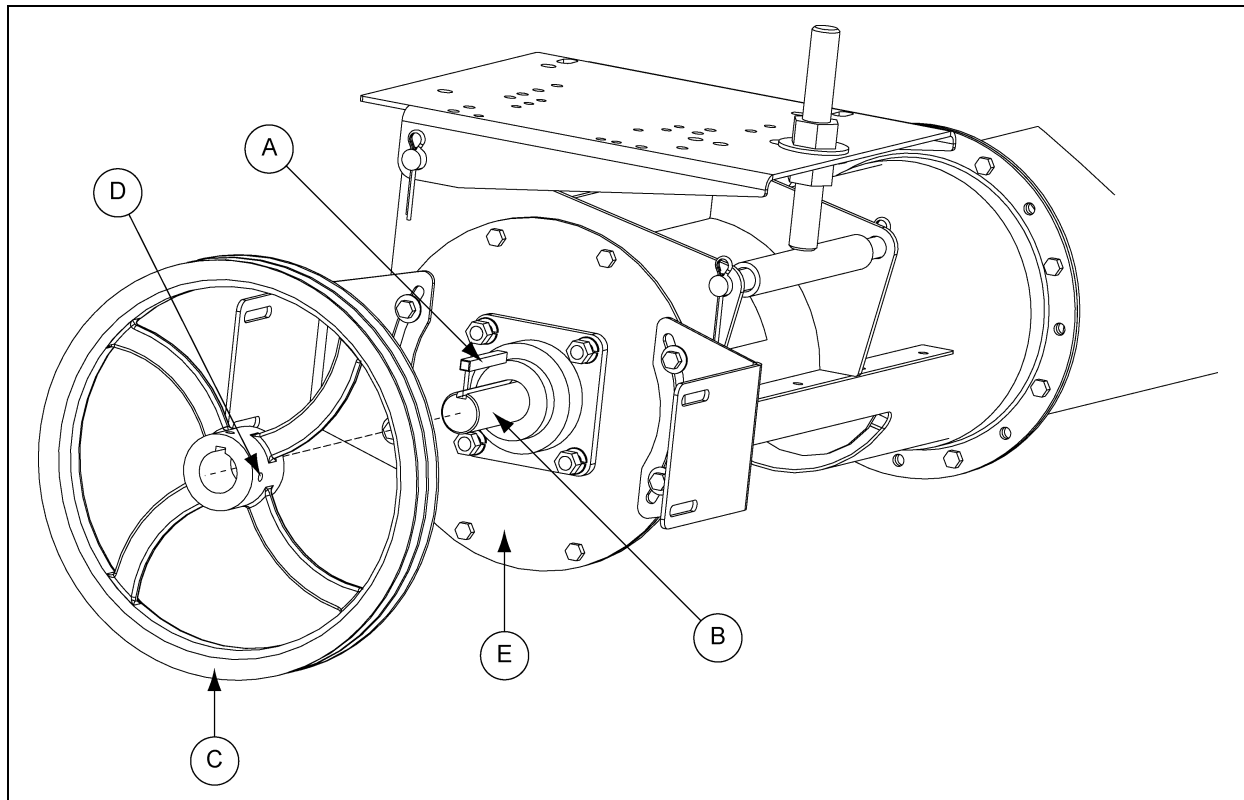

Figure 4I

Ref #	Description
A	Key
B	Drive Shaft
C	Flight Pulley
D	Set Screw
E	Bearing Plate

Tightening the Lock Collar

1. Using a punch and hammer, drive the lock collar clockwise (the same direction as the shaft rotation). Once the lock collar is set in place, use a hex head wrench to tighten the lock collar by tightening the set screw.

NOTE: If the lock collar is not turned far enough, the set screw will not lock it into place.

4. Assembly

Installing the Motor (Not Provided)

1. Attach the motor to the motor mount plate (A) using appropriate bolts, lock washers and hex nuts. *(See Chart below.)*
2. Install pulley onto motor shaft making sure that it is aligned with the flight pulley (B). It may be necessary to move spacers (C) to gain shaft alignment. *(See Figure 4J.)*

Motor Bolt Chart		
Motor Size	Hex Bolt Size	Qty
56	5/16"-18 x 1-1/4"	4
143T		
145T		
182T	3/8"-16 x 1-1/4"	4
184T		
213T		
215T		
254T	1/2"-13 x 1-3/4"	4
256T		

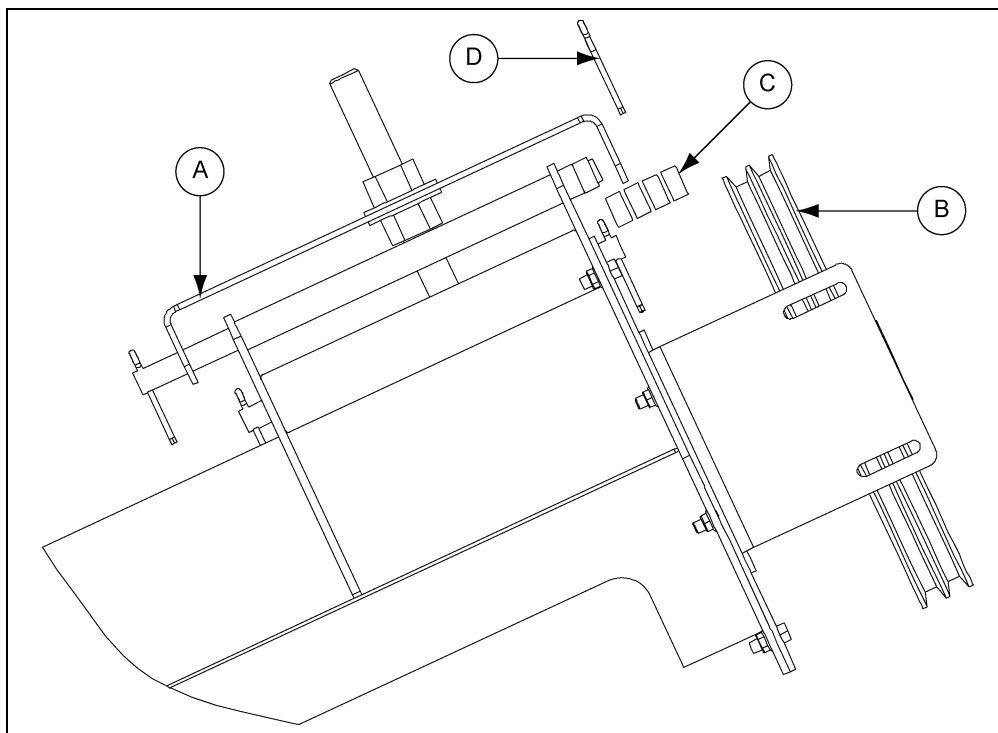

Figure 4J

Ref #	Description
A	Motor Mount Plate
B	Flight Pulley
C	Spacer
D	Cotter Pin

Installing the Belts

1. Place the belts onto the pulleys.
2. First screw the lower motor mount adjustment nut upward, raising the motor mount plate and putting tension on the belts.
3. Once the desired tension is reached, tighten the upper motor mount adjustment nut down onto the motor mount plate locking it into place.

Installing the Belt Guard

1. With the belts properly tensioned, remove the bottom belt guard cover (E) and slip belt guard down over the motor shaft.
2. Bolt the belt guard (A) to the belt guard mounting brackets (D), the brackets should still be loose at this time.
3. Align the motor shaft and the flight drive shaft in the belt guard's slot, making sure that the belt guard (A) DOES NOT contact either pulley and tighten down the belt guard mounting brackets (D) to the bearing plate. (See Figure 4K.)
4. Once the brackets are tightened, slide the bottom cover back into place and secure with supplied bolt (F).

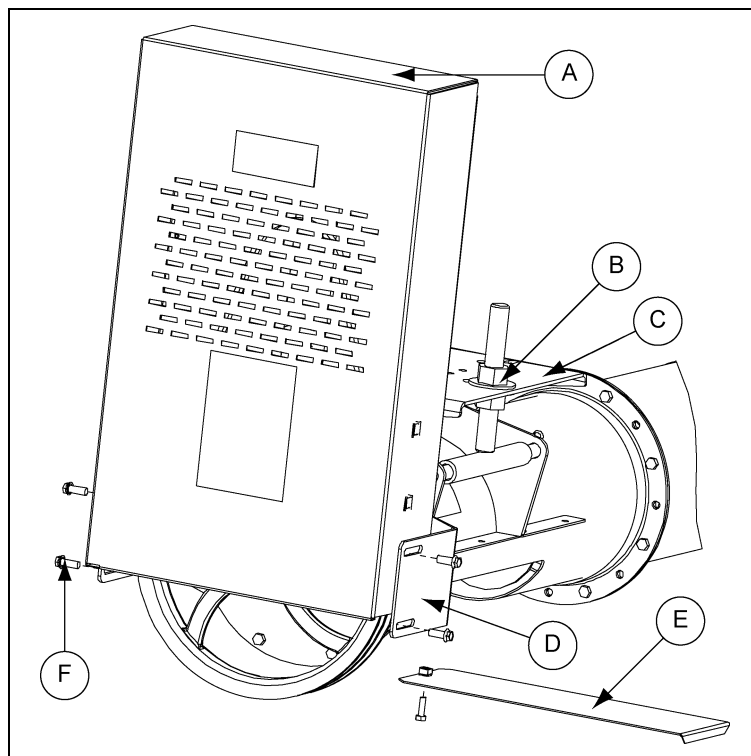

Figure 4K

Ref #	Description
A	Belt Guard
B	Motor Mount Adjustment Nut
C	Motor Mount Plate
D	Belt Guard Mounting Bracket
E	Bottom Belt Guard Cover
F	Bolt

4. Assembly

Assembling the Flight Extension for all 6", 8", 10" and 12" Custom Augers

Standard Assembly without Bearings

NOTE: If the auger does not include an extension skip ahead to [Step 5 on Page 36](#).

1. Begin by sliding the extension connecting band (A) onto the main auger tube (B). ([See Figure 4L.](#))
2. Slide the flight connecting shaft into the main section of flight (C) and bolt together with grade 8 hex bolt (D) and stover nut (G). Next slide extension flight onto connecting shaft and bolt together using proper grade 8 bolts and stover nuts (G). ([See Chart below](#) and [Figure 4M on Page 33.](#))

Flight Hardware	
6"	3/8"-16 x 2" Grade 8 Hex Bolts
8"	7/16"-14 x 3" Grade 8 Hex Bolts
10"	1/2"-13 x 3-1/2" Grade 8 Hex Bolts
12"	5/8"-11 x 4" Grade 8 Hex Bolts

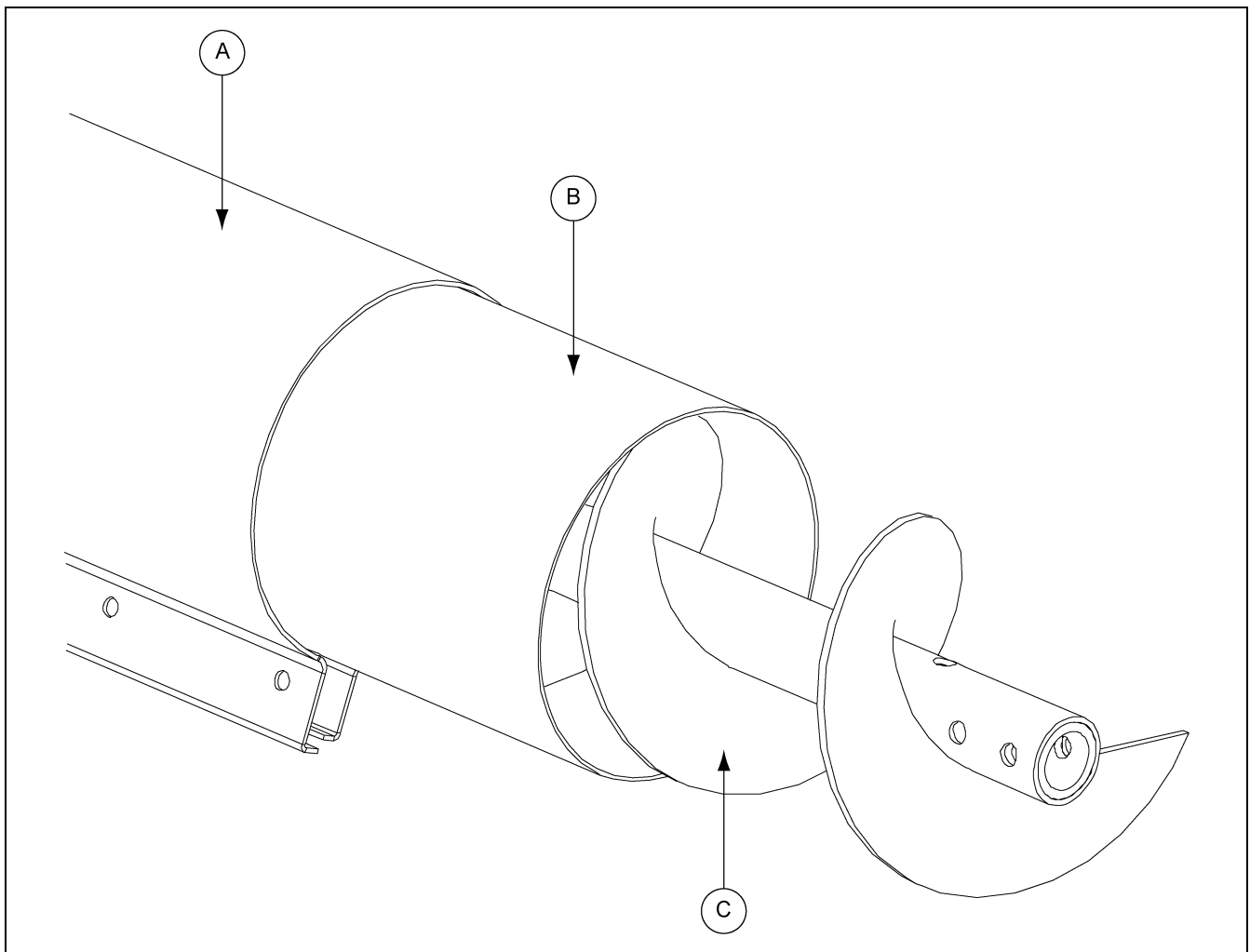

Figure 4L

Standard Assembly without Bearings (Continued)

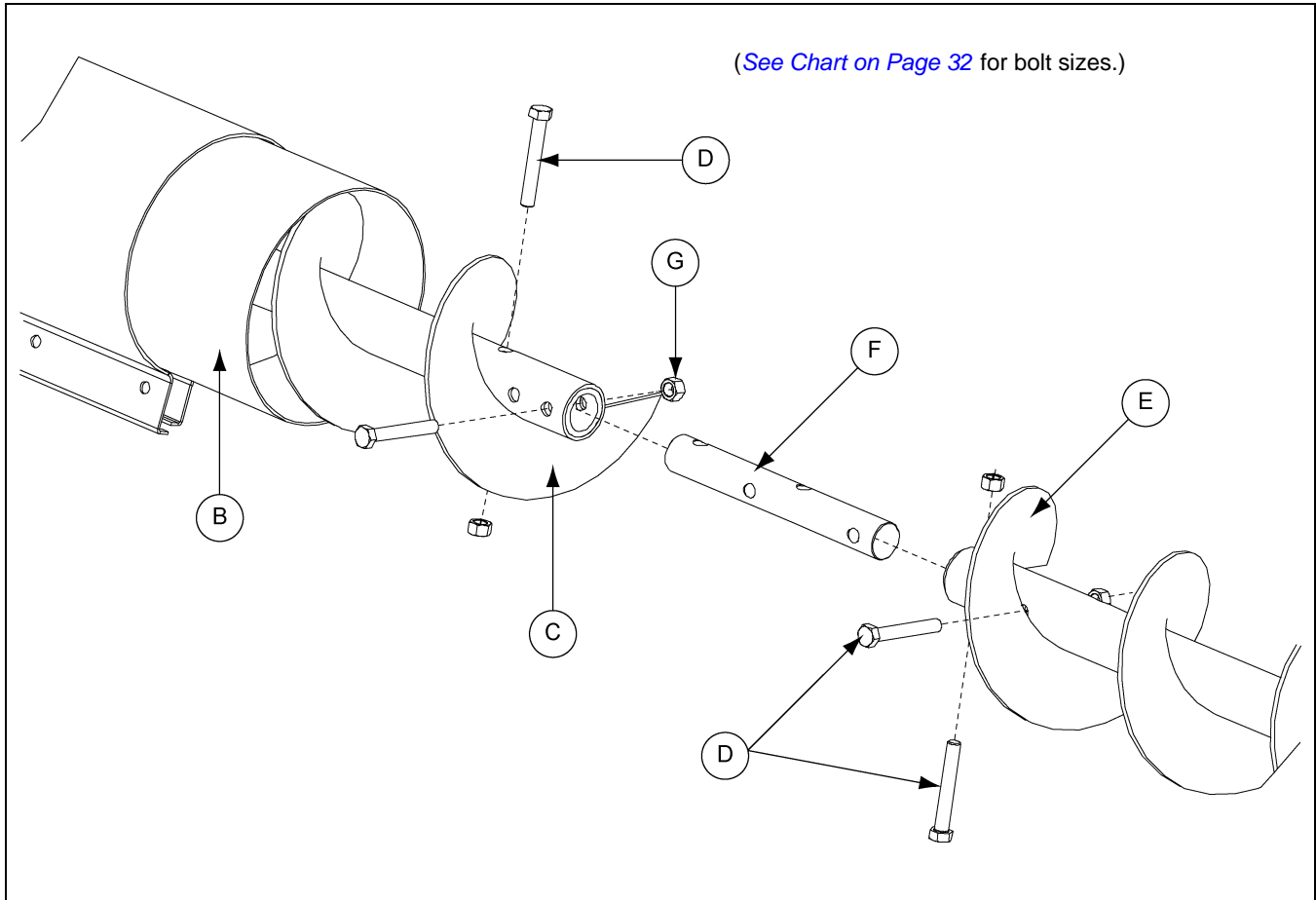

Figure 4M

Ref #	Description
A	Extension Connecting Band
B	Main Auger Tube
C	Main Flight
D	Bolts
E	Extension Flight
F	Flight Connecting Shaft
G	Stover Nut

4. Assembly

Standard Assembly without Bearings (Continued)

- Slide the extension tube (C) over the extension flight, making sure the tube is pressed securely against the main auger tube (B). (See Figure 4N.)

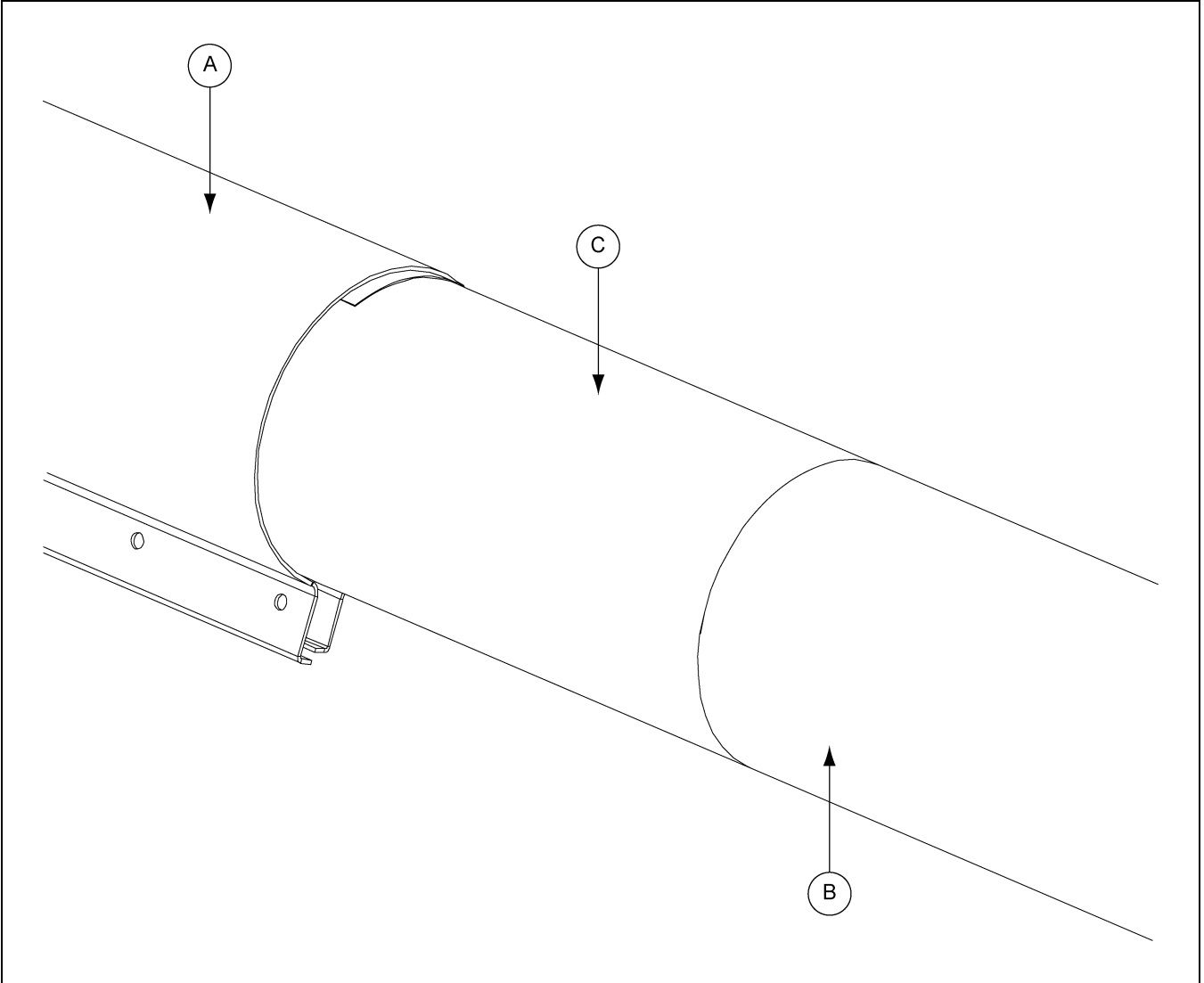

Figure 4N

Ref #	Description
A	Extension Connecting Band
B	Main Auger Tube
C	Extension Tube

Standard Assembly without Bearings (Continued)

- Slide the extension connecting band (A) over the two (2) sections of tube, making sure the connecting band is centered over the mated surfaces of the tubes. Tighten the connecting band down using the correct hex bolts (D) and nylock nuts (E). (See Chart below and Figure 40.)

Connecting Band Bolts	
6" and 8"	5/16"-18 x 1" Hex Bolt
10" and 12"	3/8"-16 x 1" Hex Bolt

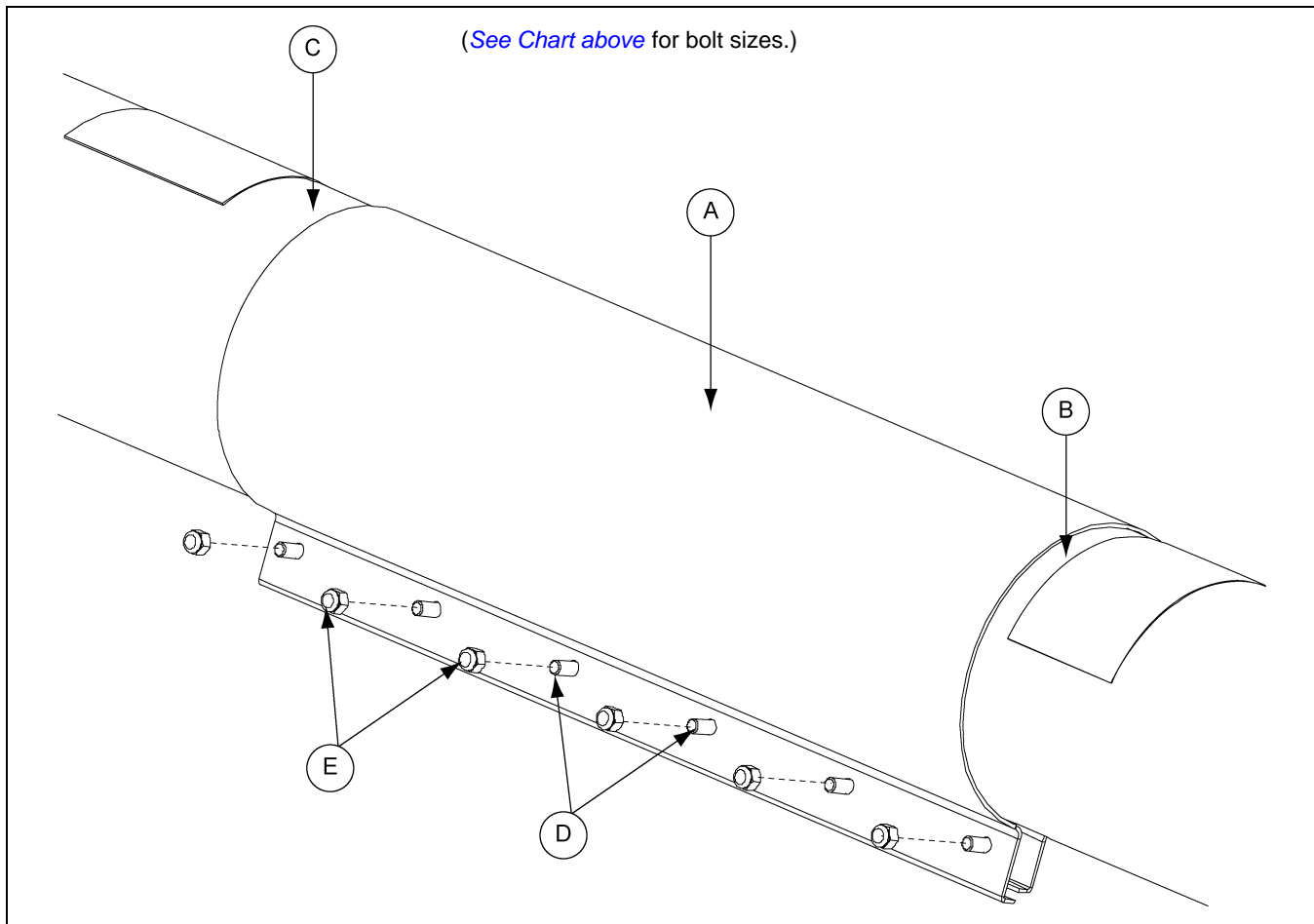

Figure 40

Ref #	Description
A	Extension Connecting Band
B	Main Auger Tube
C	Extension Tube
D	Bolts
E	Nylock Nuts

4. Assembly

Standard Assembly without Bearings (Continued)

5. Insert the intake shaft (A) into the flight (B) and connect with proper grade 8 bolt (C) and stover nut (D). (See Chart below and Figure 4P.)

Flight Hardware	
6"	3/8"-16 x 2" Grade 8 Hex Bolts
8"	7/16"-14 x 3" Grade 8 Hex Bolts
10"	1/2"-13 x 3-1/2" Grade 8 Hex Bolts
12"	5/8"-11 x 4" Grade 8 Hex Bolts

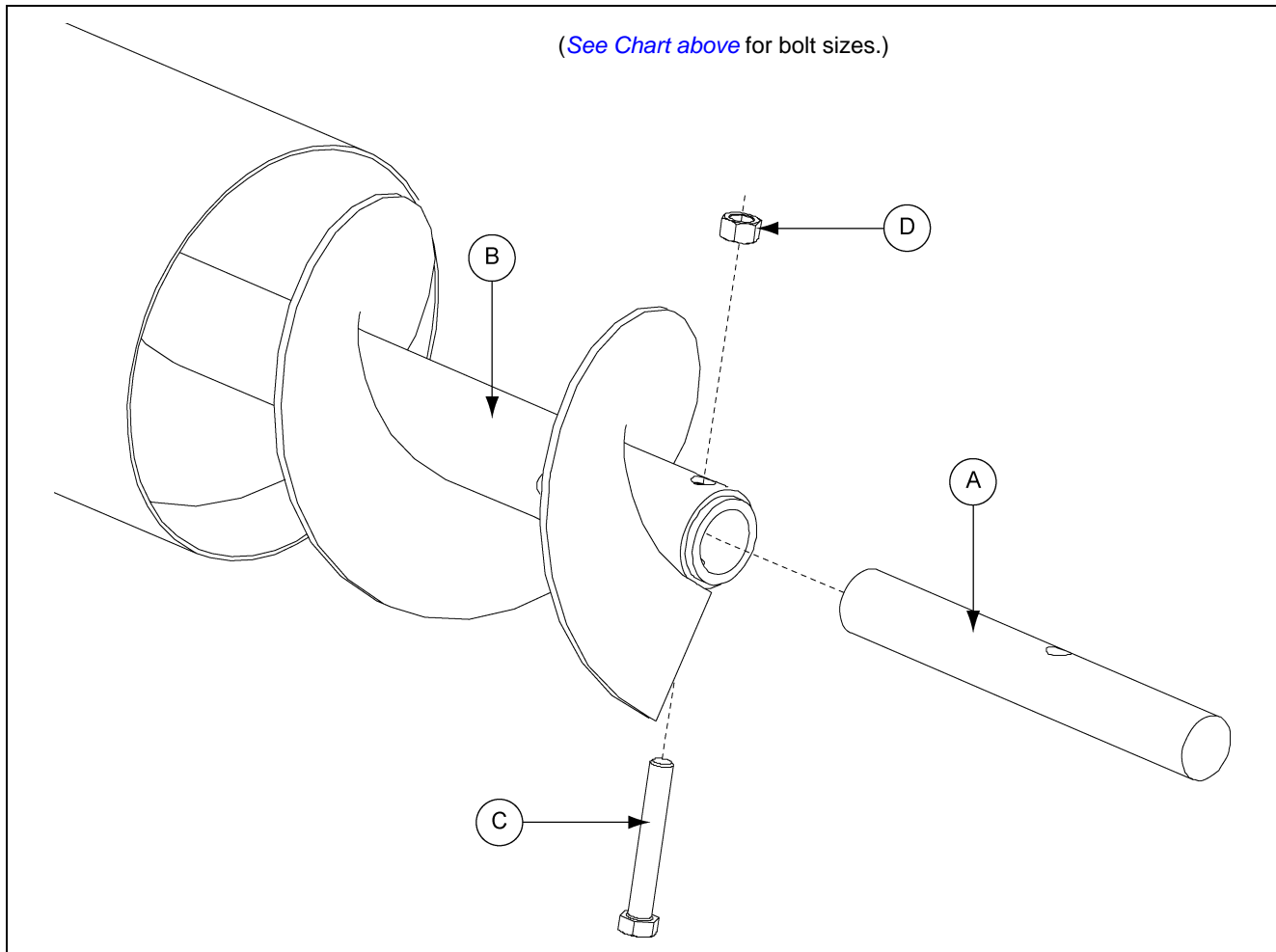

Figure 4P

Ref #	Description
A	Intake Shaft
B	Flight
C	Hex Bolt
D	Nut

Assemblies with Internal Bearings

- Slide connecting band (A) onto main auger tube (B) and attach connecting stub (D) to main auger flight (C) using the assigned hardware. (See Chart below and Figure 4Q.)

Flight Hardware	
6"	3/8"-16 x 2" Grade 8 Hex Bolts
8"	7/16"-14 x 3" Grade 8 Hex Bolts
10"	1/2"-13 x 3-1/2" Grade 8 Hex Bolts
12"	5/8"-11 x 4" Grade 8 Hex Bolts

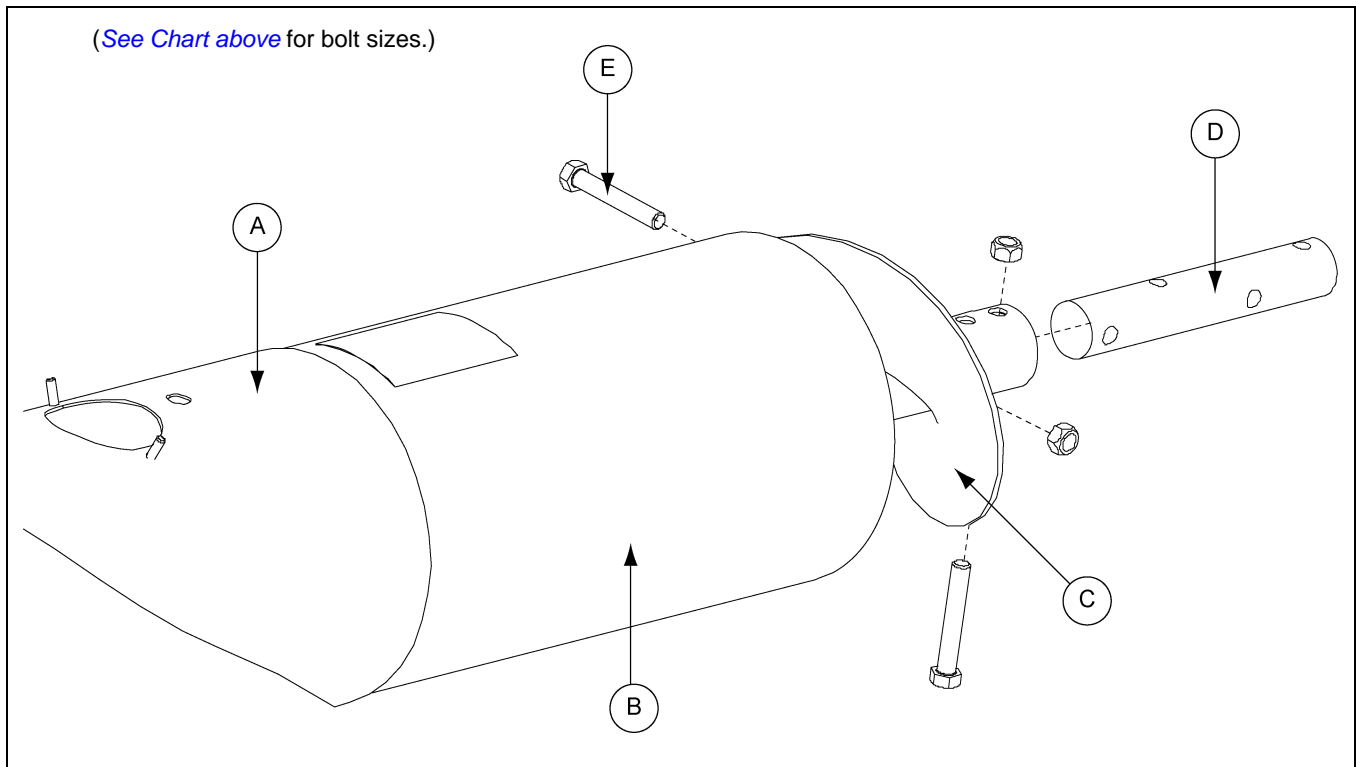

Figure 4Q

Ref #	Description
A	Connecting Band
B	Main Auger Tube
C	Main Auger Flight
D	Connecting Stub
E	Bolt

4. Assembly

Assemblies with Internal Bearings (Continued)

- Slide hanger bearing (A) onto connecting stub (D), followed by extension flight (F). Bolt extension flight (F) to connecting stub (D) using assigned hardware. (See Chart on Page 37 and Figure 4R.)

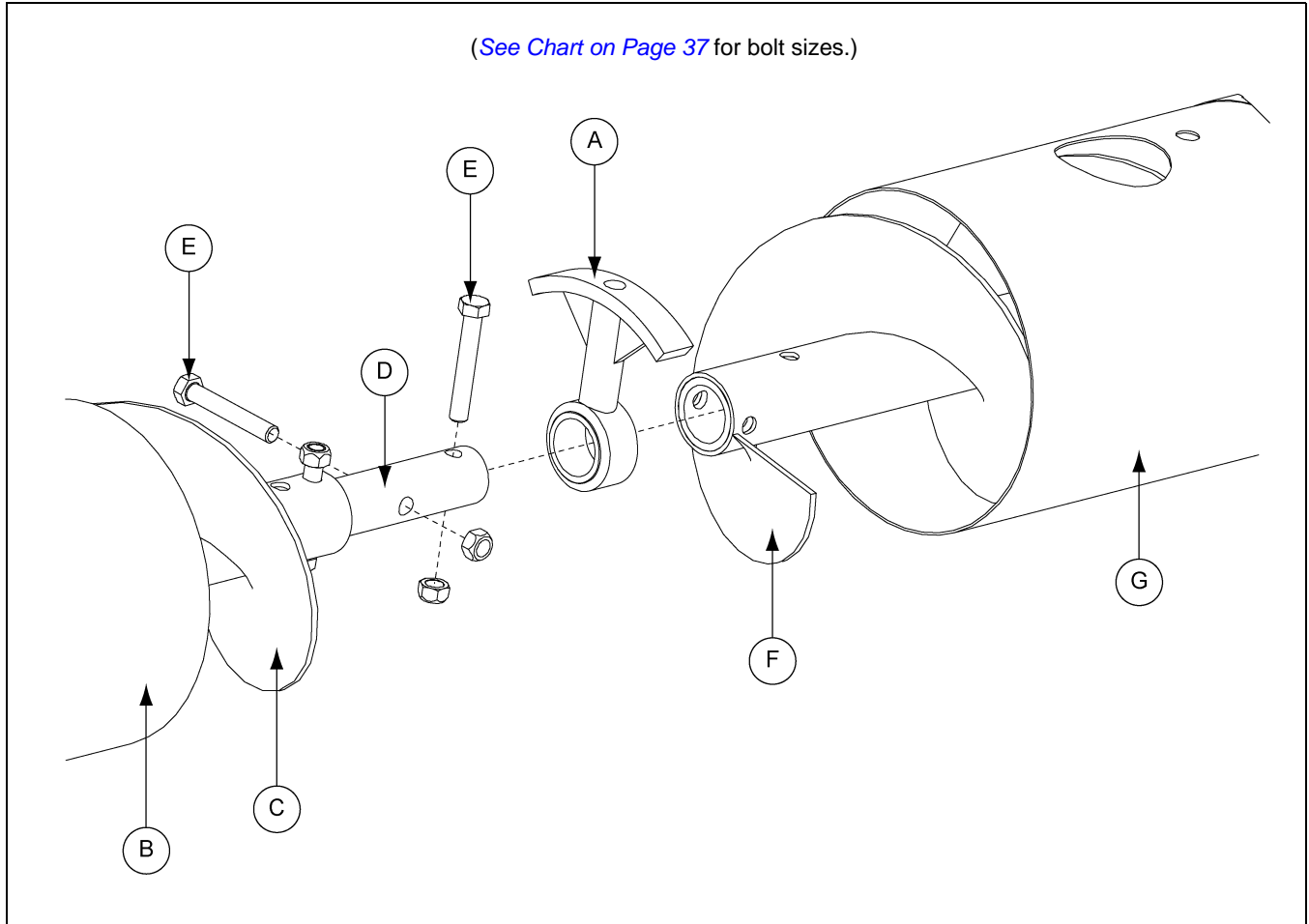

Figure 4R

Ref #	Description
A	Hanger Bearing
B	Main Auger Tube
C	Main Auger Flight
D	Connecting Stub
E	Bolts
F	Extension Flight
G	Extension Tube

Assemblies with Internal Bearings (Continued)

3. With flight sections bolted together slide extension tube (C) flush against main auger tube (B).
(See Figure 4S.)

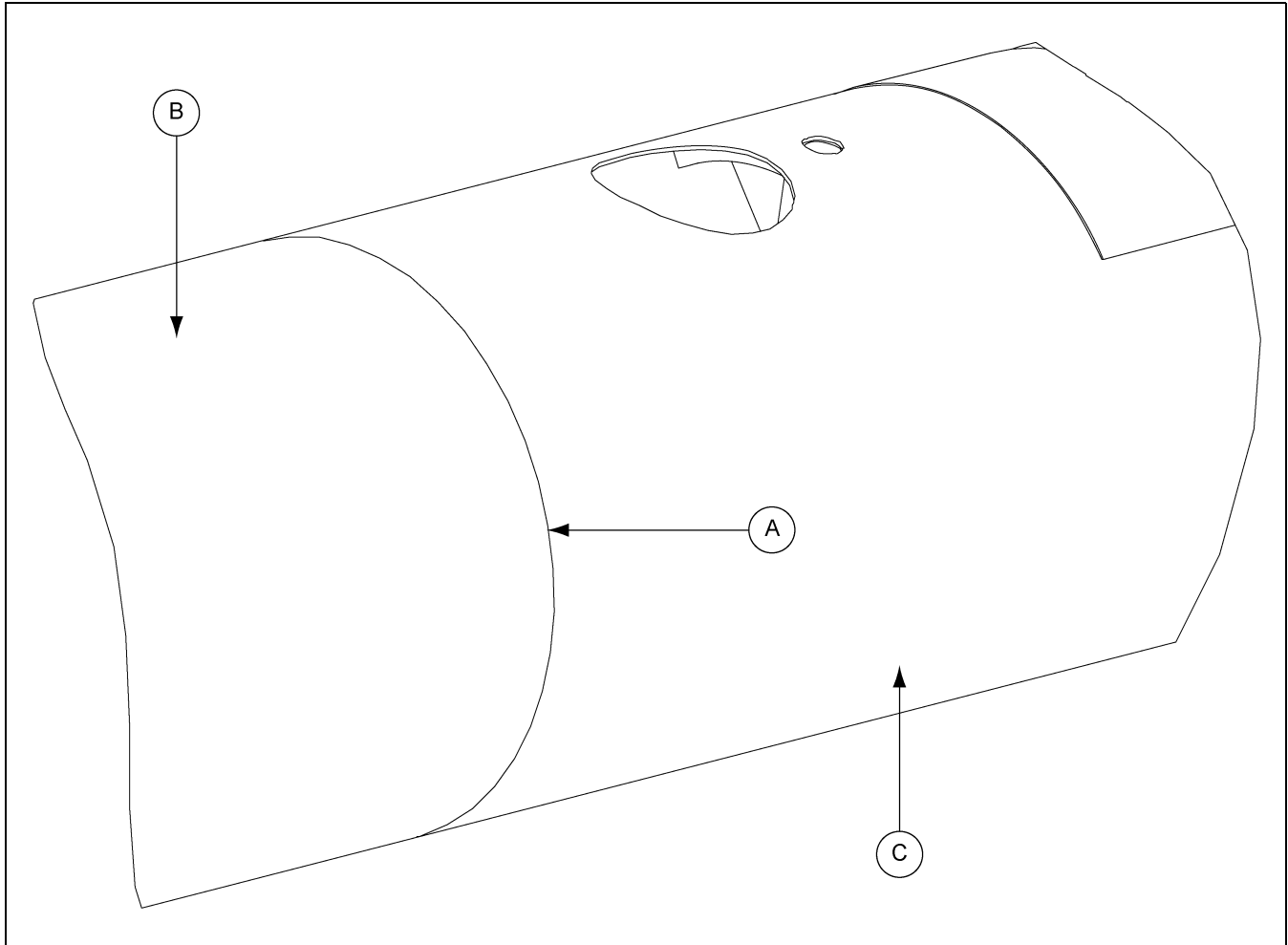

Figure 4S

Ref #	Description
A	Flush Seam Between Tubes
B	Main Auger Tube
C	Extension Tube

4. Assembly

Assemblies with Internal Bearings (Continued)

4. With tube sections pressed flush against each other slide connecting band (A) over the tubes aligning the holes. Reach through the access hole (B) and align hanger bearing with the bolt (C) hole. Attach the hanger bearing to the tube using assigned hardware. (See Chart below and Figure 4T.)

Hanger Bearing Bolt	
8"	5/8"-11 x 1-3/4" Grade 8 Bolt
10"	5/8"-11 x 1-3/4" Grade 8 Bolt
12"	3/4"-10 x 2" Grade 8 Bolt

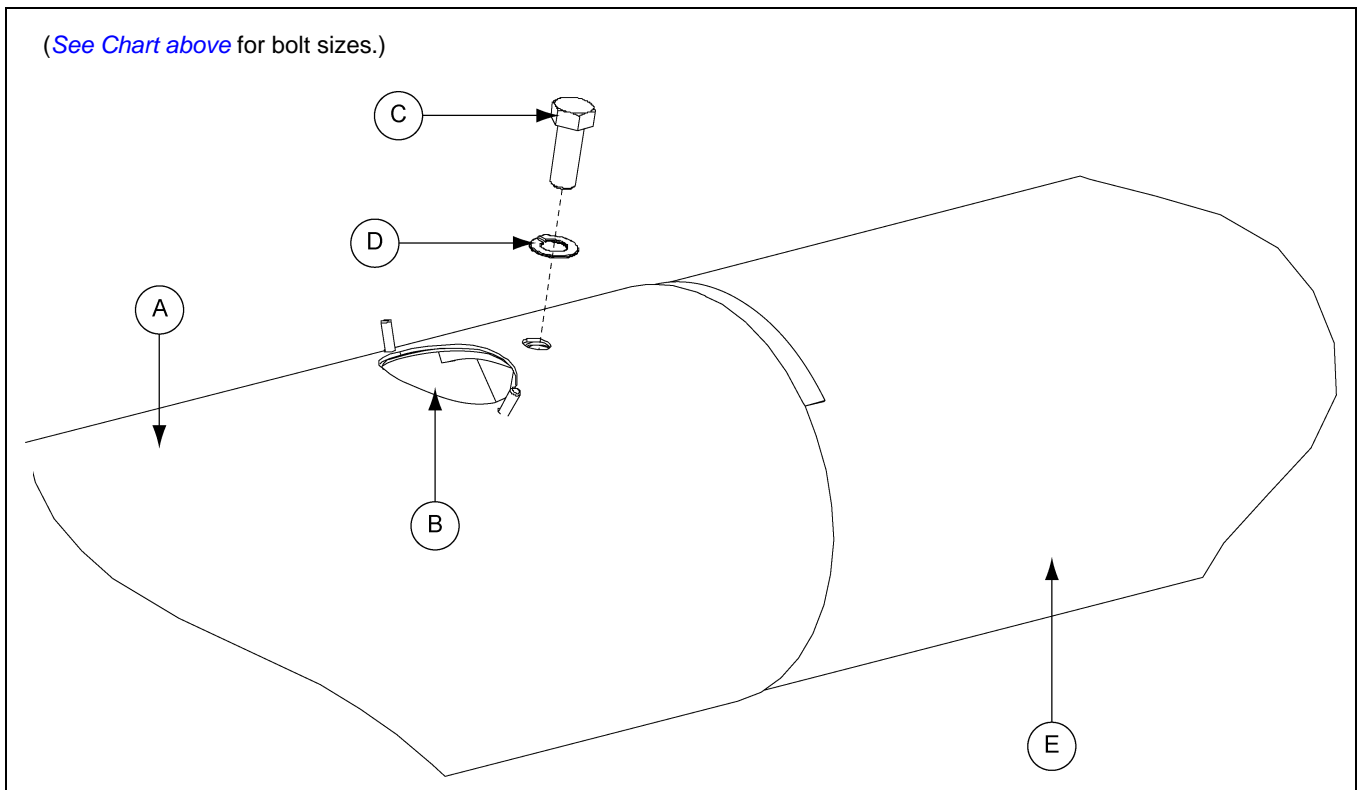

Figure 4T

Ref #	Description
A	Connecting Band
B	Access Hole
C	Hanger Bearing Bolt
D	Flat Washer
E	Extension Tube

Assemblies with Internal Bearings (Continued)

5. With hanger bearing secured bolt connecting band (A) to tubes using the 3/8"-16 x 1-1/2" hex bolts (D) and attach access cover (B) using included nylock nuts. (See Figure 4U.)

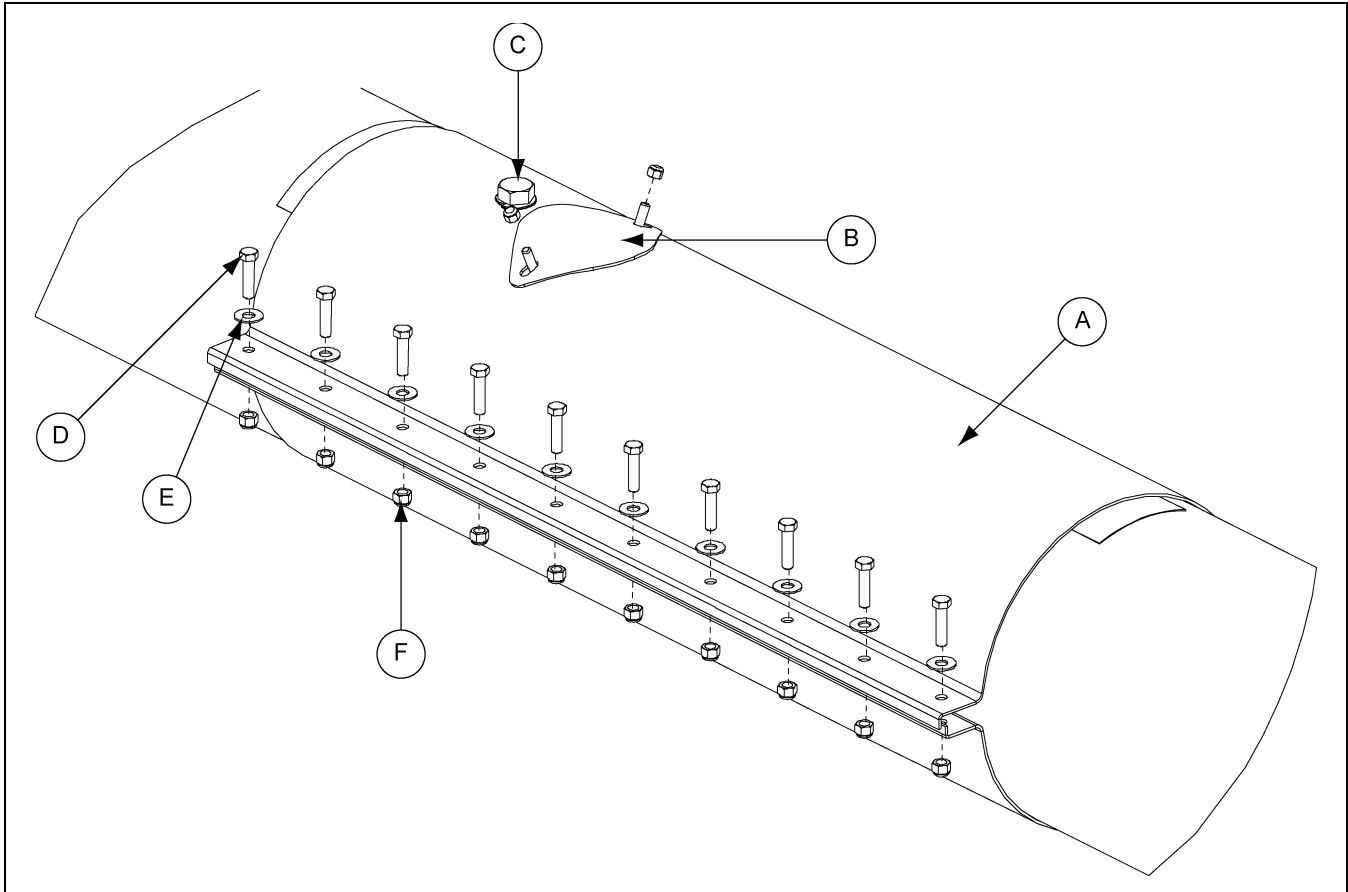

Figure 4U

Ref #	Description
A	Connecting Band
B	Access Cover
C	Hanger Bearing Bolt
D	3/8"-16 x 1-1/2" Hex Bolt
E	Flat Washer
F	Hex Nut

4. Assembly

Assembling the Inlet Hopper with Bearings for all 6", 8", 10" and 12" Custom Augers

Installing Intake Shaft

Custom augers are approved for use only where fitted with an intake hopper, with bearing and mesh guard.

1. Begin by assembling the intake shaft (A) to the flight (B) using the required grade 8 bolts (C) and stover nuts (D). (See Chart below and Figure 4V.)

Flight Hardware	
6"	3/8"-16 x 2" Grade 8 Hex Bolts
8"	7/16"-14 x 3" Grade 8 Hex Bolts
10"	1/2"-13 x 3-1/2" Grade 8 Hex Bolts

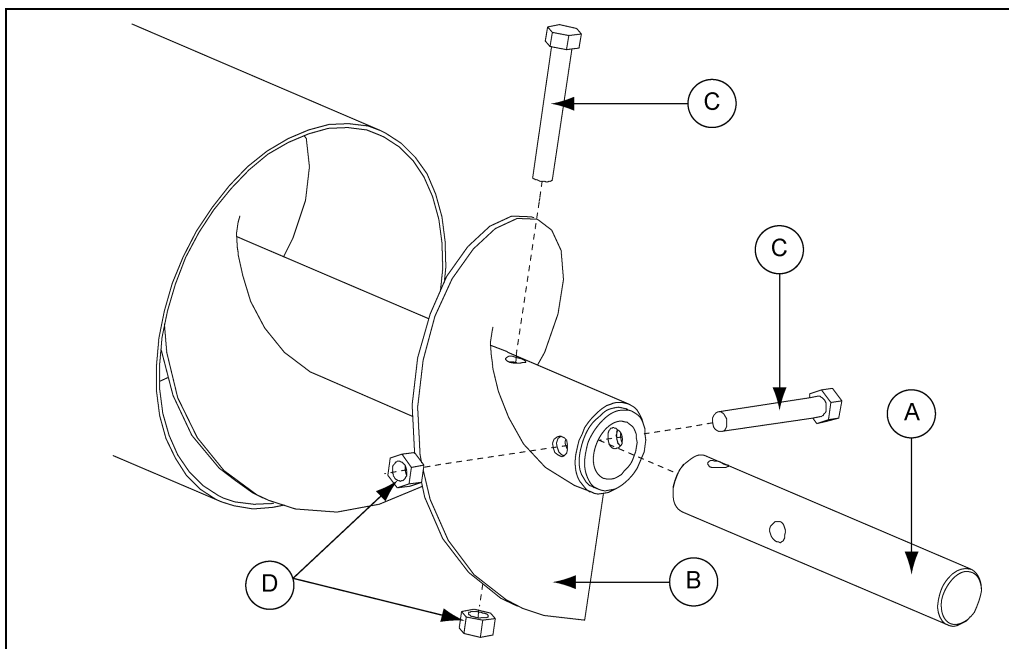

Figure 4V

Ref #	Description
A	Intake Shaft
B	Flight
C	Bolts
D	Stover Nuts

2. 6" Units require 20". It is necessary to field cut auger tube lengths to accommodate required exposure. Butt the auger tube to the unloader tube and attach using a connecting band.

IMPORTANT: Auger stub shaft supplied is designed to fit GSI 6" bulk tank augers. If using a different auger supplier it may be necessary to modify or fabricate a stub shaft for the unloader bearing.

Installing Intake Shaft (Continued)

3. Next bolt the bearing (A) with flangette to the studs (C) on the hopper (B) using the required lock washer (D) and nut (E). (See Chart below and Figure 4W.)

Hopper Bearing Nut	
6"	5/16"-18 Hex Nut
8"	3/8"-16 Hex Nut
10"	1/2"-13 Hex Nut

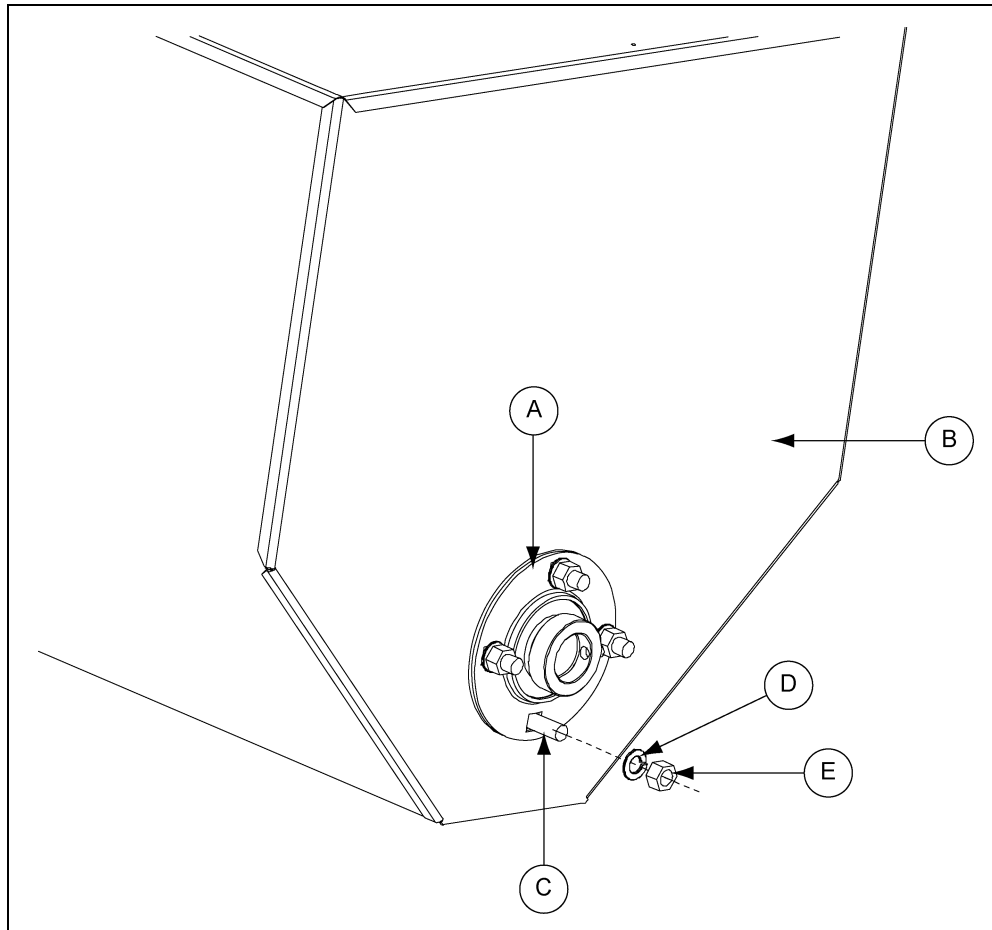

Figure 4W

Ref #	Description
A	Bearing
B	Hopper
C	Stud
D	Lock Washer
E	Nut

4. Assembly

Attach Hopper

- Slide the hopper (A) onto the tube and align the end of the flight approximately 12 mm from the surface of the bearing (B). With the proper distance set, install the proper bolt (C), lock washer (D) and nut (E) and secure the hopper (A) to the tube. *(See Chart below and Figure 4X.)*

Hopper Connecting Band Bolt	
6" and 8"	5/16"-18 x 1" Hex Bolt
10"	5/16"-18 x 1-1/2" Hex Bolt

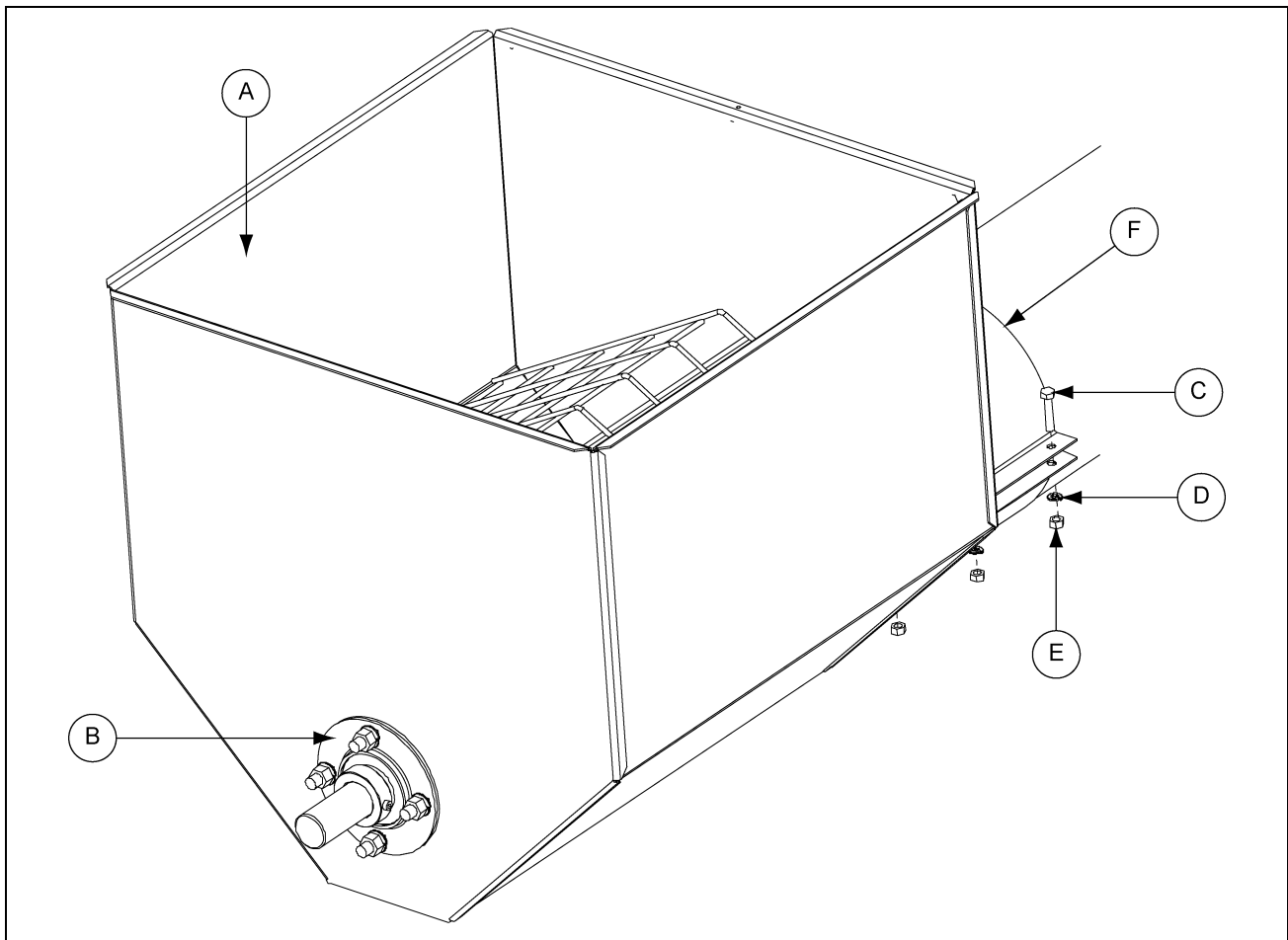

Figure 4X

Ref #	Description
A	Hopper
B	Bearing
C	Bolt
D	Lock Washer
E	Nut
F	Connecting Band

Attaching Discharge Spout and Grain Tube



NEVER operate the auger without a discharge spout and grain tube to a minimum length of 850 mm OR directly connect the discharge to other handling equipment.

1. Auger flight and shaft must be fully enclosed or inaccessible.
2. Align the spout (A) holes with those on the motor tube.
3. Fix with hardware as shown in [Figure 4Y](#).

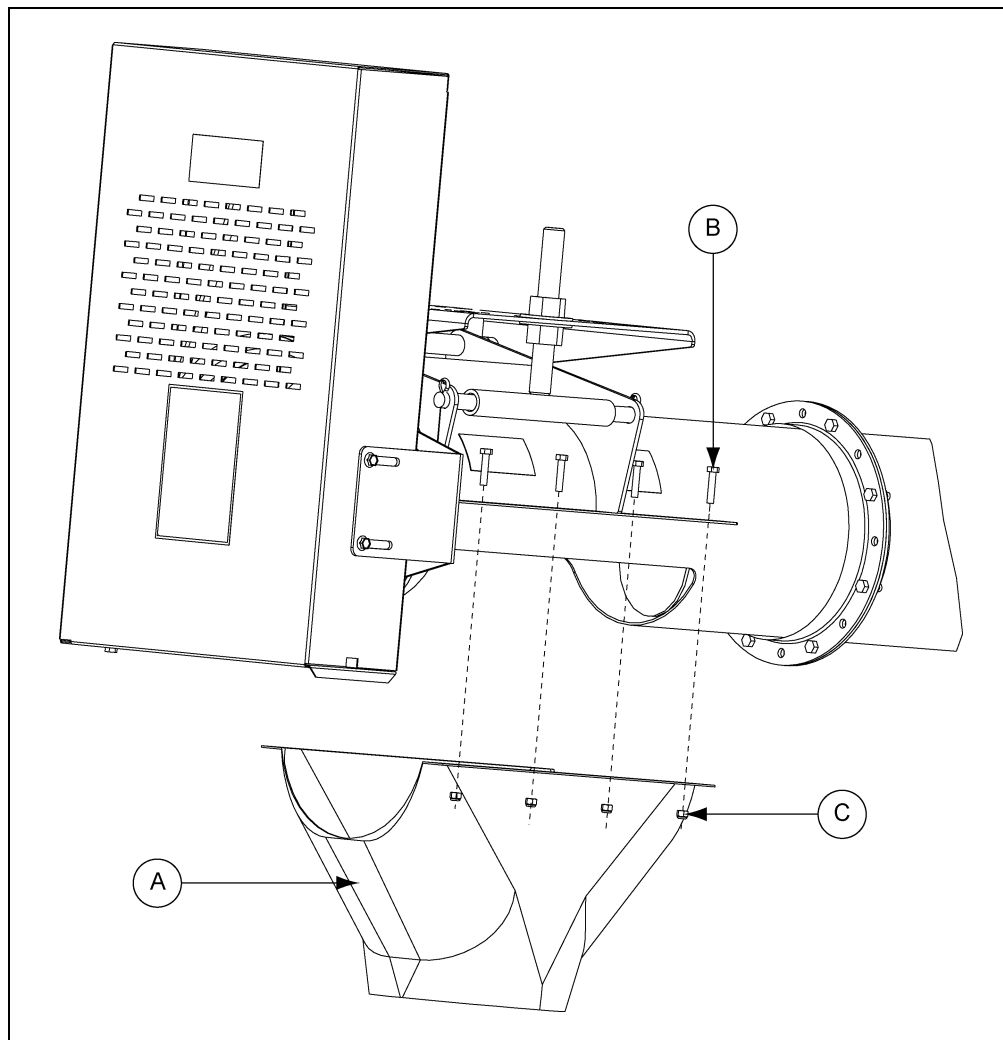

Figure 4Y

Ref #	Description
A	Spout
B	5/16" x 1-1/2" Hex Bolt
C	Lock Nut

4. Assembly

Attaching Discharge Spout and Grain Tube (Continued)

4. EITHER fit the length of steel grain tube supplied with the outlet spout and attach with nuts and bolts or weld to the discharge spout. (See Figure 4Z.)

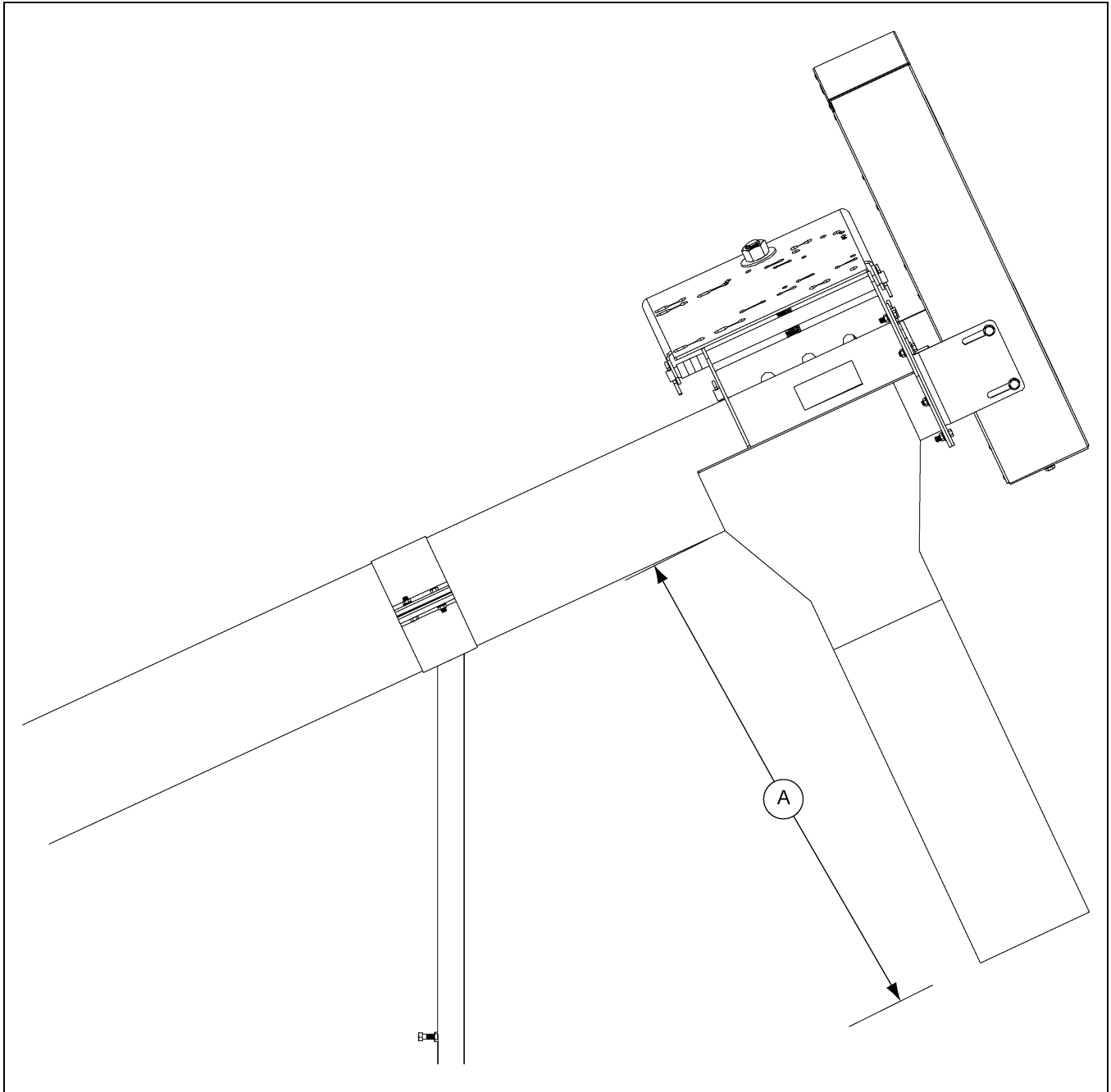

Figure 4Z

Ref #	Description
A	850 mm Minimum

5. OR connect the outlet direct to other equipment.

Outlet Cutting Guidelines

1. Outlets must be fitted with outlet spout and minimum 850 mm long steel tube or be coupled directly to another piece of conveying equipment, so that the augers flights are not exposed or accessible. Before ordering, predetermine the location of the outlet drops. Make sure the outlet drops do not interfere with the connecting band locations.
2. When an outlet opening is cut, that section of tube loses much of its strength therefore additional support may be necessary.
3. If you have internal bearing flighting, outlets may be cut below internal bearings but a hole must cut in the spout half band allow access to internal hanger bearing.
4. We recommend removing flight before cutting the tube otherwise flight will be notched and/or rough edges will occur. This may not significantly impact the performance of the auger, but burrs and metal chips should be removed or abnormal wear will result. Also, grind down any rough edges on tubing for a better fit and smoother operation.
5. Carefully measure the outlet before cutting. Follow the recommended guidelines as shown *in Figure 4AA*. It is very important that the opening be large enough not to reduce capacity, but small enough so the outlet can be covered securely by the spout.

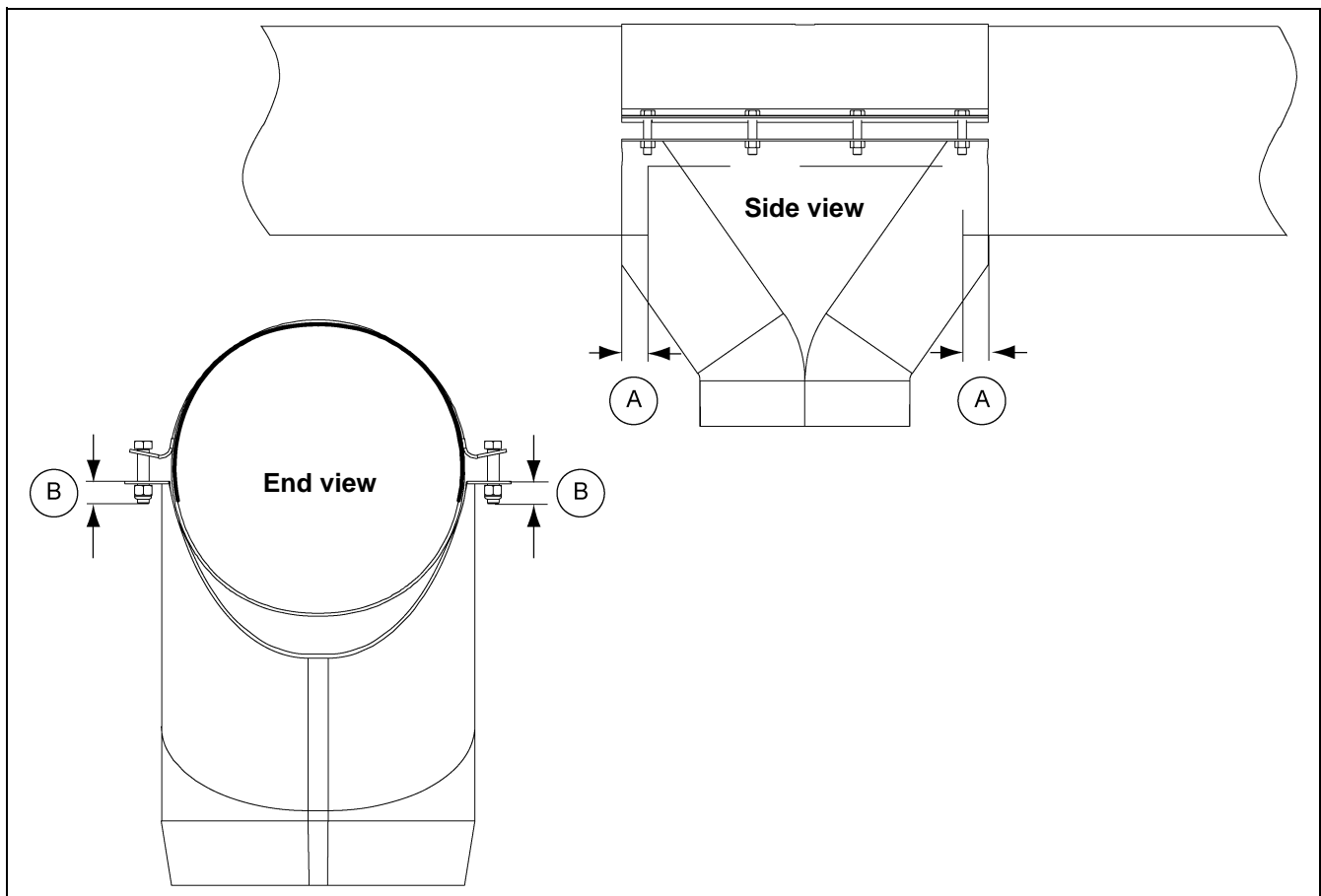

Figure 4AA

Ref #	Description
A	1"
B	1/2"

4. Assembly

Enclosed Slide Gates with Rack and Pinion Control

1. Follow cutting guidelines [on Page 47](#).
2. Attach spout to tube with backband (A).
3. Remove smaller outside nut from the rack and pinion connecting rod and insert rod through the hole in the angle on the slide gate and secure with the smaller outside nut.
4. Fully close slide gate (D). Using the pulley (C), adjust the half bands (B) so they are located at the end of the control rod farthest from the spout (E). Then tighten the half bands (B) to the tube.
5. Wrap rope or cable around the pulley (C), doubling it to prevent slippage.

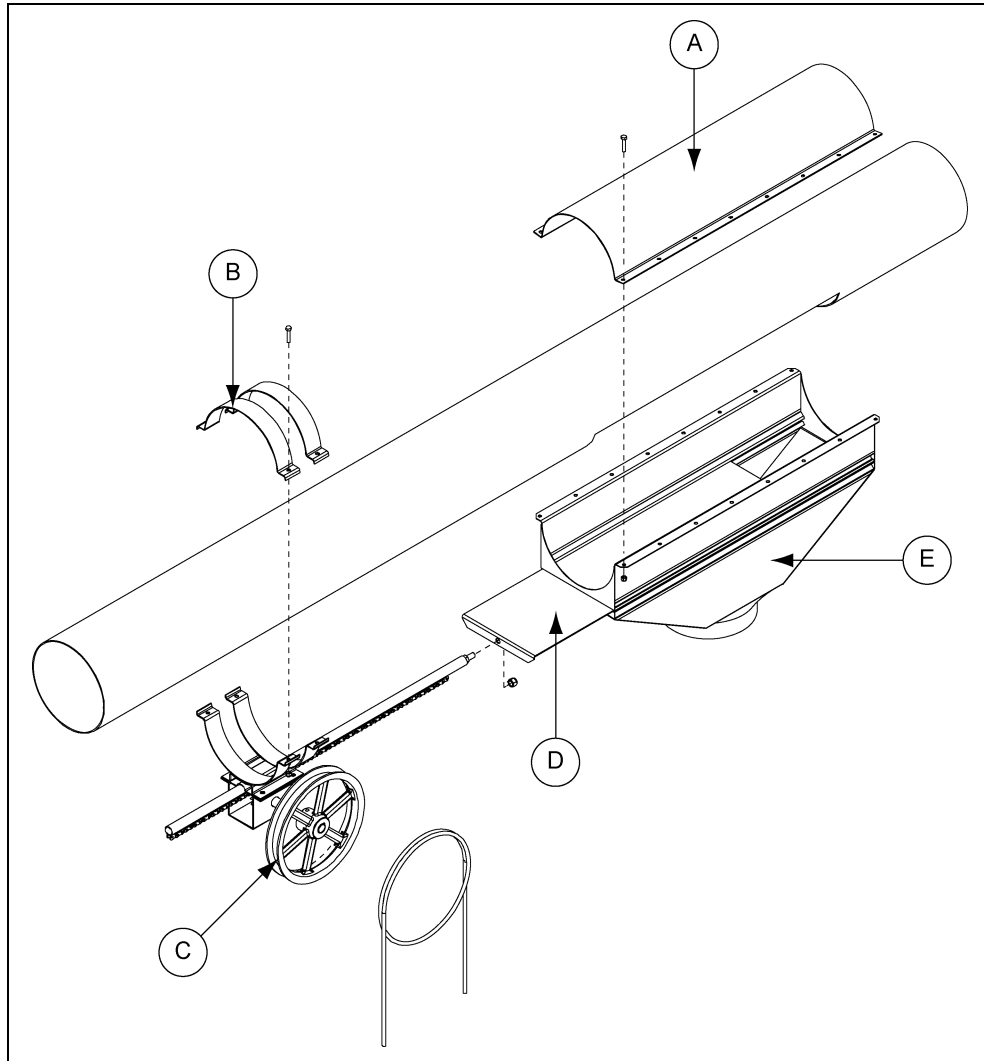

Figure 4AB Rack and Pinion Control

Ref #	Description
A	Backband
B	Half Band
C	Pulley
D	Slide Gate
E	Spout

Basic Inlet Hoppers

1. Basic inlet hopper must include a steel mesh screen guard. Follow the cutting guidelines [on Page 47](#).
2. Attach hoppers to tube as shown [in Figure 4AC](#).
3. Follow the instructions below before cutting and installing inlet hopper.
 - a. Slide ring flange onto the end of tube and weld, making sure the flange is mounted squarely.
 - b. Bolt end plate to flange.
 - c. Bolt bearing to end plate.
 - d. Guide intake stub through bearing and tighten the lock collar.
 - e. Install any covers if applicable.

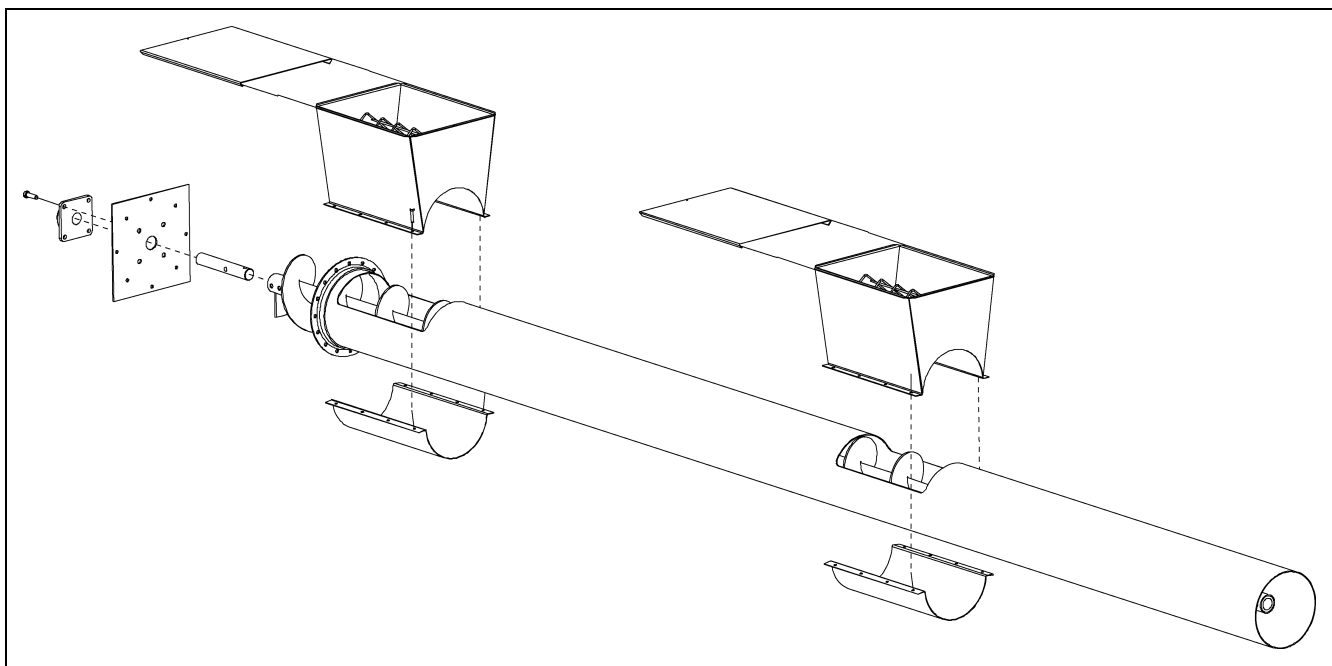

Figure 4AC

Spouting, Fittings and Truss Kits

Spouting and Fittings

To connect sections of spouting or to connect fittings to spouting, use one or all of the following procedures:

1. Spouting to Spouting - Slide flange rings over ends of spouting to be joined and weld in place. Make sure flanges are mounted squarely. Join flanges and bolt together.
2. Spouting to Fitting - Install ring flange on spouting as in [Step 1](#). Join to flange on fitting (valve, dead head, slip joints, etc.).
3. Flange Clamps - Fit each half over flanges and tighten with bolts provided.
4. Quick Connect Flange Clamps - Fit each half over flange and tighten bolt. Do not use in location where permanent unions are required.

4. Assembly

Truss Kits

Truss rod kits are designed to provide support for spouting and certain auger sections. There are two (2) different kits available for trussing. 20' to 30' Span kits and 30' to 40' span kits for spouting only. See the instructions that are included with the kit for proper installation.

Sample Custom Auger Configurations

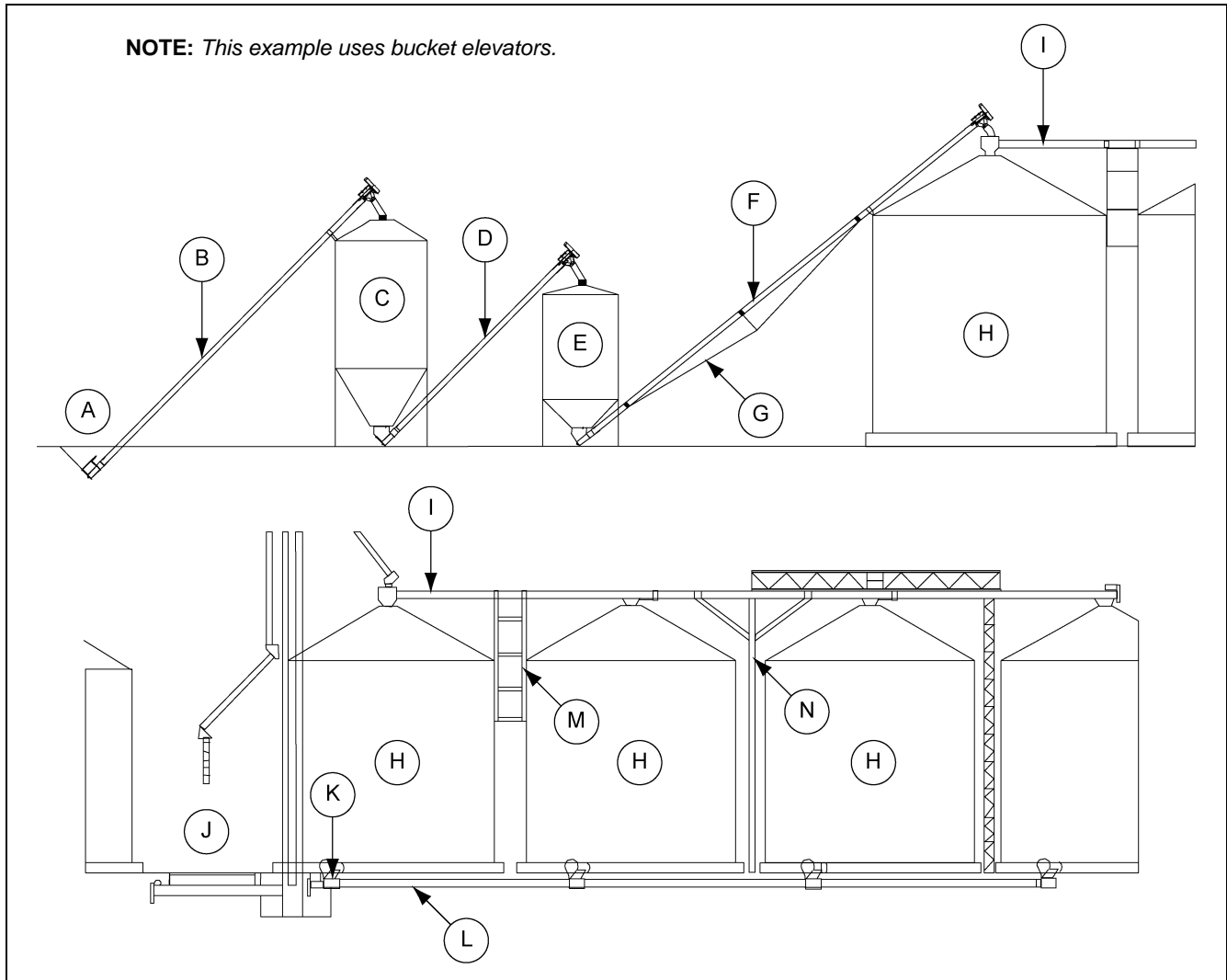

Figure 4AD

Ref #	Description
A	Pit
B	Dump Pit to Wet Holding Tank
C	Wet Holding Tank
D	Wet Holding Tank to Dryer
E	Dryer
F	Dryer to Cooling Bin
G	Truss Kit

Ref #	Description
H	Storage Bin
I	Overhead Distributing Auger
J	Drive Over Hopper
K	Bin Unload Auger
L	Unloader Set in Trench with Unloading Tubes. Return Unload Auger.
M	Tower Support by Bin Side not Roof
N	Tower to Ground

Use as a Roof Auger - Installing the Auger Stands

1. Attach the tallest stand (B) on the motor mount side of the connecting flange. It is necessary to place the stand on the motor mount side of the flange to help support the weight of the motor.
(See Figure 4AE.)

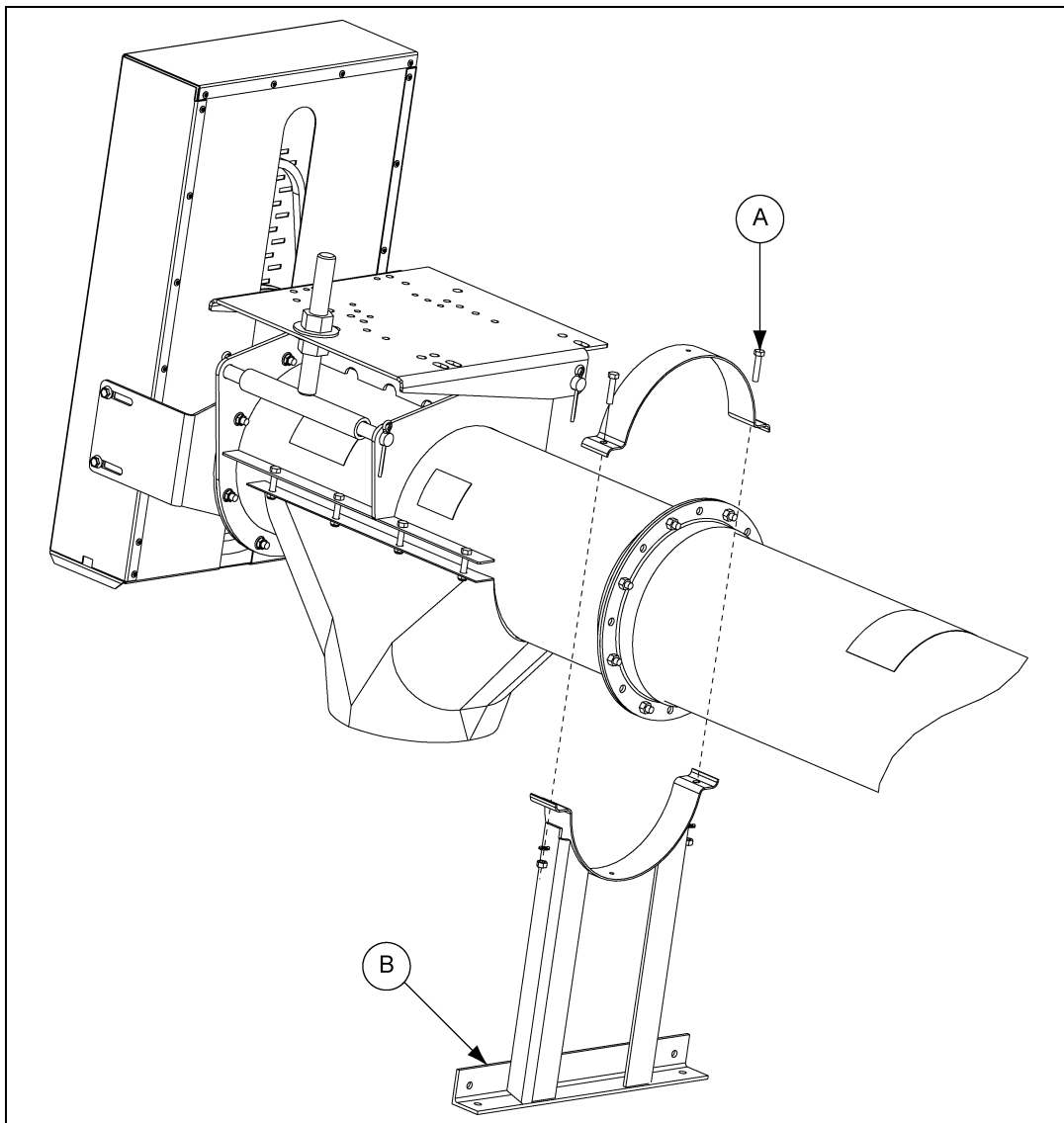

Figure 4AE

Ref #	Description
A	5/16" x 1-1/2" Hex bolt
B	Tall Stand



**Do not place roof auger support stands directly on roof panel surface.
Attach stands to angle iron that spans completely across the roof panel ribs.**

4. Assembly

Use as a Roof Auger - Installing the Auger Stands (Continued)

2. Install the shortest stand (B) as close to the intake hopper as possible. Positioning the stand as close as possible to the hopper will help to distribute the hoppers weight. (See Figure 4AF.)

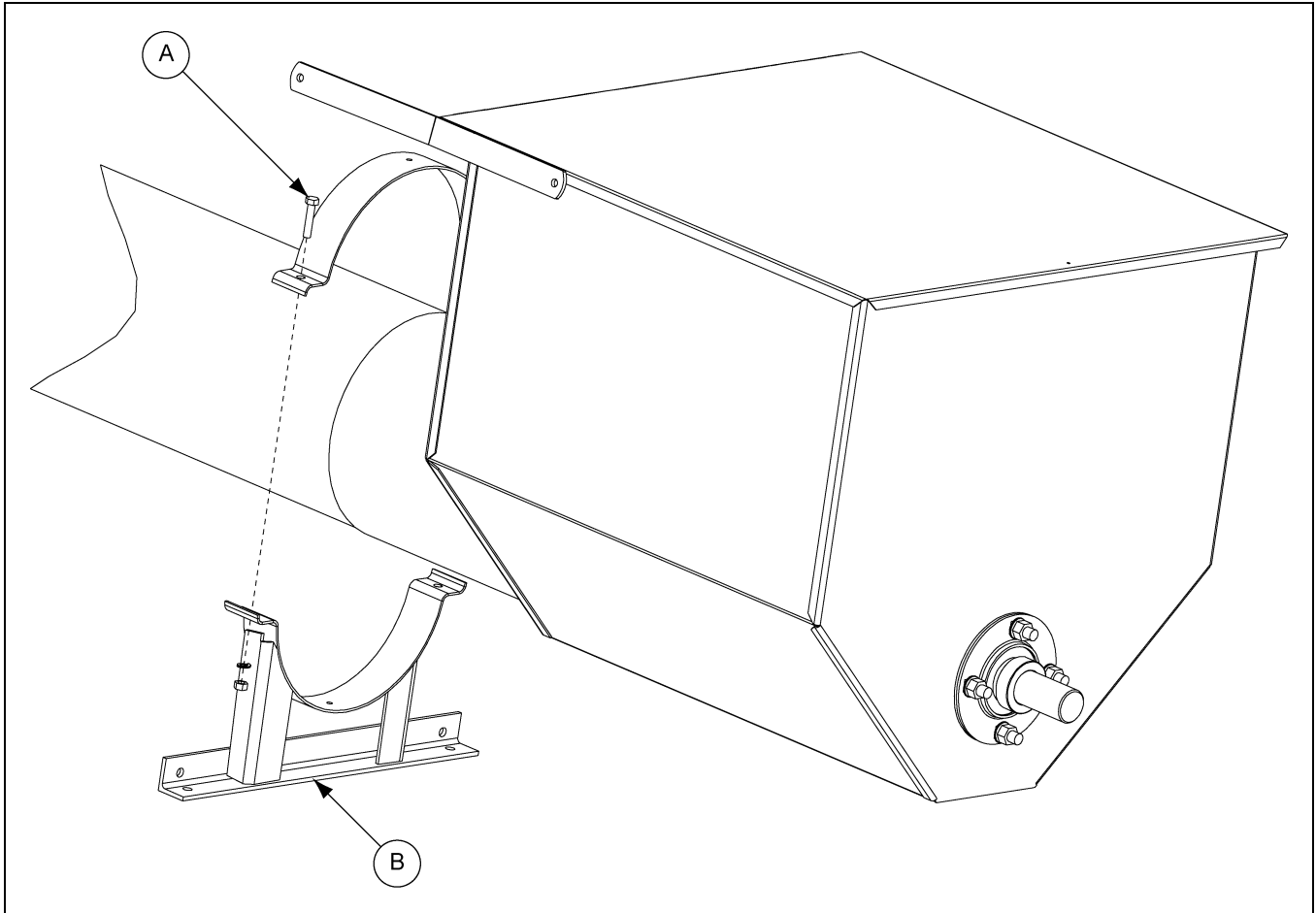

Figure 4AF

Ref #	Description
A	5/16" x 1-1/2" Hex Bolt
B	Short Stand

Use as a Roof Auger - Installing the Auger Stands (Continued)

3. Install the remaining stand in the center of the tube. Placing the stand in the center of the tube will help minimize vibration in the system when the auger is running. (See Figure 4AG.)

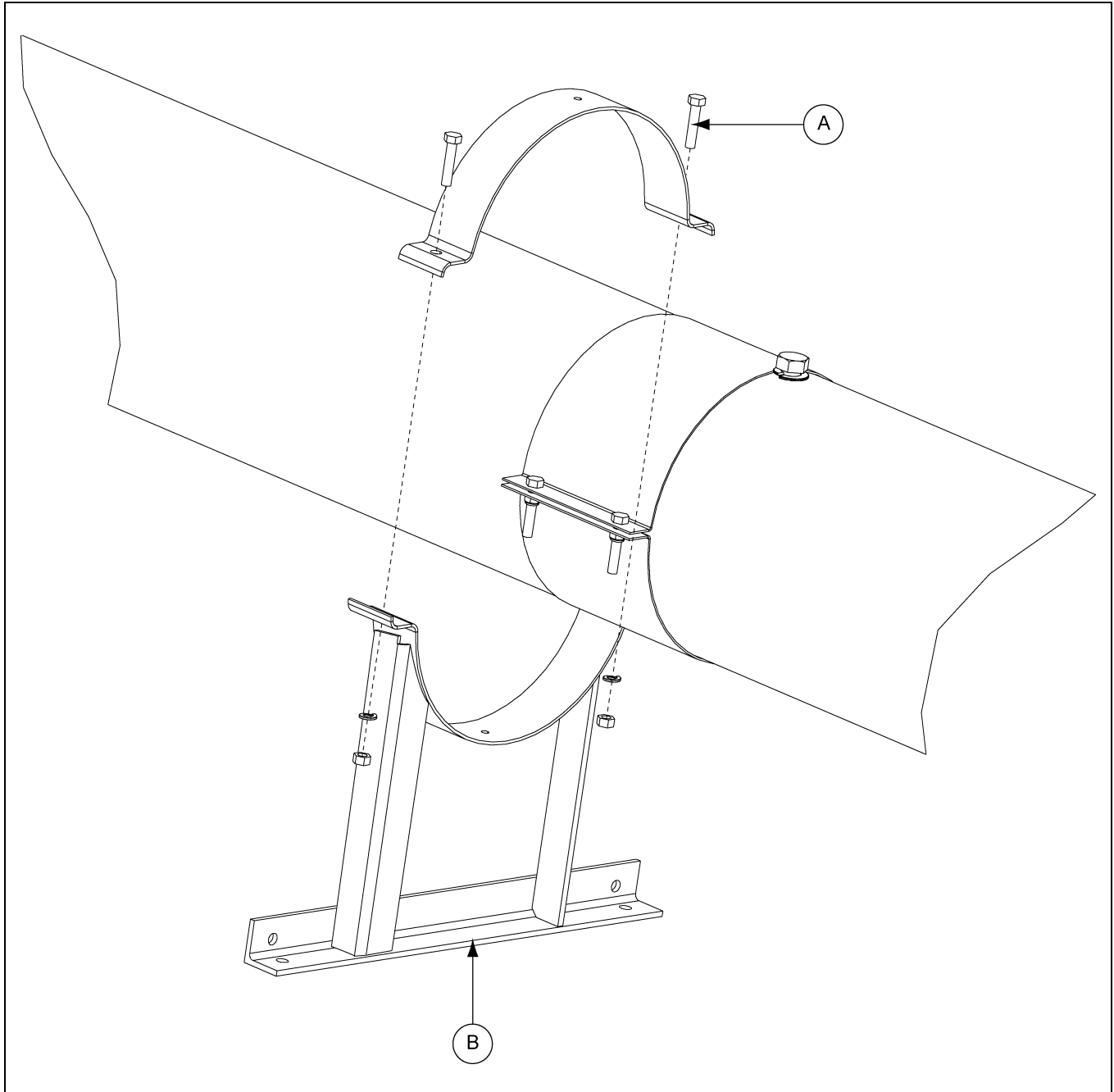

Figure 4AG

Ref #	Description
A	5/16" x 1-1/2" Hex Bolt
B	Center Stand

Horsepower Information for Electric Motors

- Horsepower recommendations are for augering reasonably dry grain at different angles. Grain with 15% moisture and above may require more horsepower if maximum capacity is to be maintained. Use a 2-1/2" to 3" motor pulley for a recommended auger speed of 550 RPM to 650 RPM motor pulley not furnished. Excessive wear will result if auger speed is in excess of 700 RPM and auger load up will occur if auger speed is less than 500 RPM or flow gate is required.
- Auger speeds in excess of 750 RPM should be avoided as excessive wear will result. Auger speeds below 450 RPM require a flow control to restrict intake to the auger. High torque is required to turn the flighting if it is permitted to "load up" at low speed and damage to the auger can result. An optional control gate is available for this purpose.

The charts below are a suggested horsepower requirement for standard 6", 8" and 10" roof augers.

6" Horsepower Chart			
Length	11'	16'	21'
Motor HP	1 - 1.5	1 - 1.5	1.5 - 2

8" Horsepower Chart			
Length	11'	16'	21'
Motor HP	1.5 - 2	1.5 - 2	2 - 3

10" Horsepower Chart			
Length	11'	16'	21'
Motor HP	2 - 3	2 - 3	3 - 5



Electrical controls and wiring should be installed by a qualified electrician. The motor disconnect switches and conductor cables should comply with the National Electrical Code and any local codes which apply. Motor starting control stations should be so located that the operator can see that all personnel are clear of the equipment.

Start-Up and Break-In



ALWAYS keep ALL guards and shields in place until all the power is disconnected and locked out.

1. Make sure all belts are tensioned properly.
2. Make sure ALL shields are in place and that the belt(s) and pulley(s) are able to move freely.
3. Double check the assembly instructions to see that all parts have been assembled properly.
4. During operation of equipment, one person should be in a position to monitor the entire operation.

NOTE: *During the initial start-up and break-in period, the operator should note any unusual vibrations or noises and take the appropriate action.*



Make certain everyone is clear before operating or moving the machine.

5. The bin well inside the bin should have a control gate. The gate should be closed before start-up and closed before shut down to allow the machine to clean out.
6. The controls for the control gate should either pull or push open, depending on the type of well in use. Use the control gate to regulate a flow of less than full capacity until several hundred bushels of grain have been augured to polish the flighting assembly and tube.
7. Any new screw conveyor or one that has set idle for a season should go through a “break-in” period. This “break-in” consists of running the auger at half capacity until the screw becomes polished and smooth before attempting to run at full capacity. It is recommended that several hundred bushels of grain be augured at partial capacity.

NOTICE

Failure of the auger is very likely to occur if it is run at full capacity before the screw has become polished.

NOTICE

NEVER operate augers empty for any length of time as excessive wear will result.

8. Do not stop or start augers under load, especially before the flight and tube become well polished, as this may cause the auger to “lock up”.

NOTICE

Excessive wear will result if auger is run at speeds in excess of what is recommended.

9. Do not run auger at too slow of a speed as this will load up or overload the auger. An loading up of the auger will cause the motor to overload and a higher torque will be required to turn the auger, which in turn may cause damage to the auger.

Operate the Auger

NOTE: *The auger capacity can fluctuate greatly under varying conditions. Moisture content, different commodities, amount of foreign matter and speeds all play a part in the performance of the auger. Twenty-five percent (25%) moisture may cut capacity by as much as 40% under some conditions.*

1. Make certain there are at least two (2) people in the work area to monitor operations at all times.
2. Visually inspect the auger periodically during operation.



Be alert for any unusual vibrations, noises and the loosening of any fasteners. If anything unusual is detected, immediately shut down the auger, disconnect and lock out the power source before servicing.

3. Consideration should be given to the proper size auger for a batch drying or any intermittent type operations. When augers are stopped and restarted under full load, it may result in damage to the auger. Using a larger diameter auger and reducing its load level will be far better than subjecting a smaller diameter auger to big loads. If an auger is kept from absolute filling, it will make start-up easier and will convey more efficiently.

Maintain the Auger



ALWAYS shut down and disconnect the power supply before adjusting, servicing or cleaning the equipment.

1. Use caution when repairing or replacing equipment parts.
2. Make sure ALL decals are legible and tightly attached to the auger. If necessary, replace them **FREE OF CHARGE** by contacting the dealer or the manufacturer.
3. Ensure that ALL electric motors, etc., are operating at the proper speed.
4. Maintain proper adjustments on the belt(s).
5. Mount controls for any electric motors at a safe distance from the machine and in a location accessible in case of an emergency.
6. Make sure ALL electrical wiring is not damaged and that it meets proper wiring codes.
7. Make sure ALL components are in good working condition before use.
8. Check the auger flighting to make sure it is in good working condition.
9. Check the internal bearing bracket, bearing and universal joint to make sure they are in good working order.
10. Grease bearing at least two (2) times each season.

Normal Shut Down

1. Make certain unloading tubes are empty before stopping the unit.
2. Disconnect and lock out the power source before leaving the work area.

Emergency Shut Down

1. Know how to shut down the auger in case of an emergency.
2. Disconnect and lock out the power source.
3. Close bin well control gates.
4. Clear out as much grain from the auger and hopper as possible.

NOTICE

Never restart when under a full load. Starting unit under load may result in damage to the machine. Such damage is considered abuse of the equipment.

5. Re-connect and unlock the power source.
6. Gradually clear the auger until there is no grain or obstruction.

Lock Out

1. Always stop and disconnect the power source whenever the operator must leave the work area or for maintenance of the machinery.
2. Make sure equipment is locked out and that the machinery cannot be started while the operator is not in the work area.



Use the type of main power disconnect switch that is capable of being locked only in the OFF position.

Storage Preparation

1. Close all wells to discharge tube.
2. Be sure the unload tube is empty.
3. Make sure power source is disconnected and locked out.
4. Check to see that all fasteners are secure.

NOTES

1. **6" Custom Auger Parts** - *(See Pages 60 and 61.)*
2. **8" Custom Auger Parts** - *(See Pages 62 and 63.)*
3. **8" Internal Bearing Parts** - *(See Pages 64 and 65.)*
4. **10" Custom Auger Parts** - *(See Pages 66 and 67.)*
5. **10" Internal Bearing Parts** - *(See Pages 68 and 69.)*
6. **12" Custom Auger Parts** - *(See Pages 70 and 71.)*
7. **12" Internal Bearing Parts** - *(See Pages 72 and 73.)*
8. **6" Roof Augers Parts** - *(See Pages 74 and 75.)*
9. **8" Roof Augers Parts** - *(See Pages 76 and 77.)*
10. **10" Roof Augers Parts** - *(See Pages 78 and 79.)*

6" Custom Auger Parts

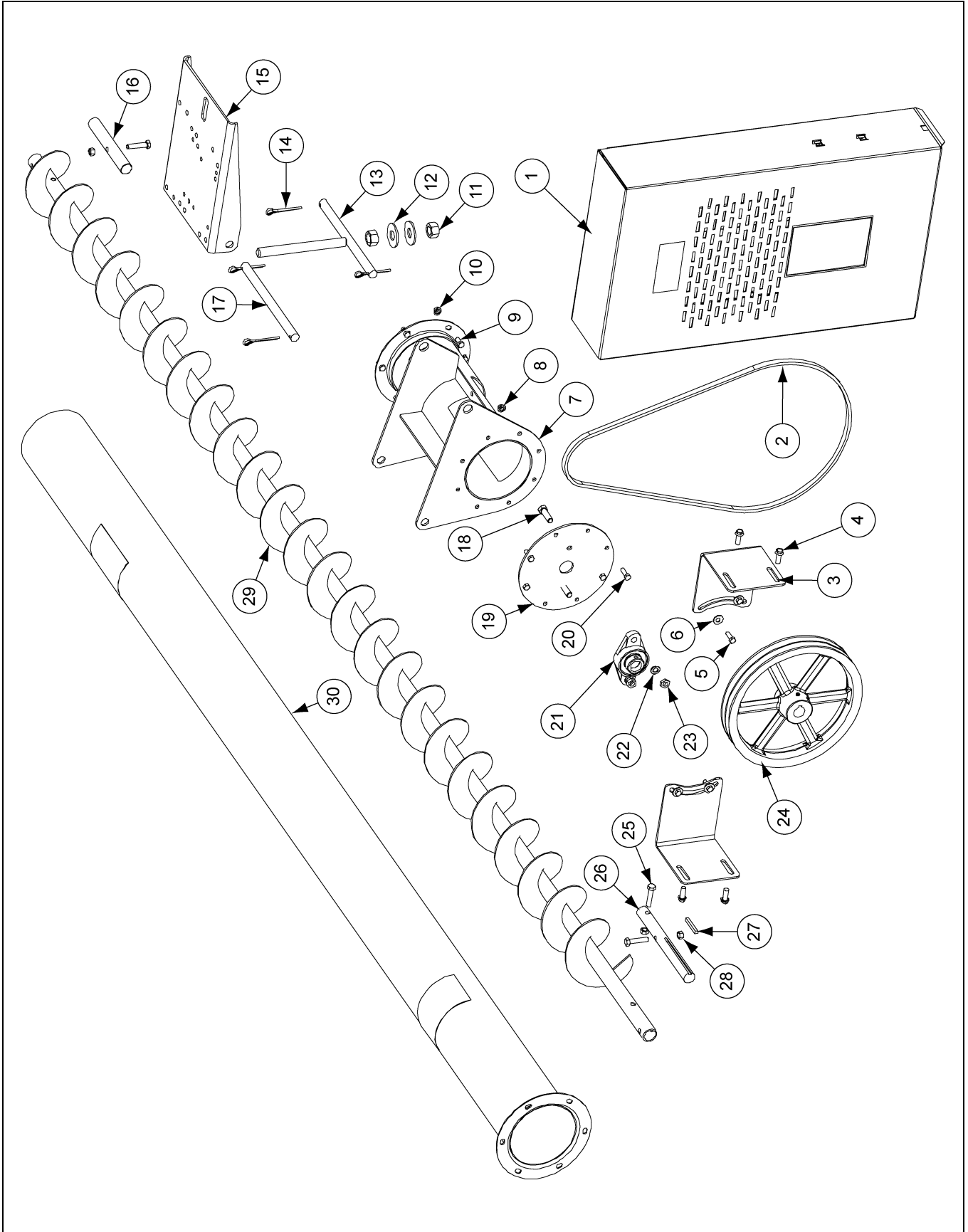

6" Custom Auger Parts List

Ref #	Part #	Description
1	GK7005	15" Belt Guard Assembly
2	GK1323	V-Belt B48
2	GK2349	V-Belt B54
3	GK7062	6" Belt Guard Mounting Bracket
4	S-9065	Flange Bolt 3/8"-16 x 1" ZN Grade 5
5	S-1196	Bolt, HHCS 5/16"-18 x 1" ZN Grade 5
6	S-845	Flat Washer 5/16" USS SAE YDP Grade 2
7	GK6996	6" Horizontal Tube Assembly
8	S-3611	Flange Nut 5/16"-18 YDP Grade 2
9	S-275	Bolt, HH Bin 5/16"-18 x 3/4" YDP Grade 5
10	S-3611	Flange Nut 5/16"-18 YDP Grade 2
11	S-234	Hex Nut 3/4"-10 ZN Grade 5, Zinc Plated
12	S-866	Flat Washer 3/4" USS ZN Grade 2
13	GK7060	6" Motor Mount Adjustment Rod Weldment
14	S-6994	Cotter Pin 3/16" x 2" ZN Grade 2
15	GK7052-Y	6" Motor Plate
16	GK1117	Shaft: Intake 1" Diameter x 7"
17	GK7058	6" Motor Mount Plate Pivot Rod
18	S-7837	Bolt, HHCS 7/16"-14 x 1-1/2" ZN Grade 5
19	GK7061-BS	6" Horizontal Bearing Plate - Bin Silver
20	S-1196	Bolt, HHCS 5/16"-18 x 1" ZN Grade 5
21	GK1049	Light Duty 1" Bore 2 Hole Flange with Locking Collar Bearing
22	S-7014	Split Lock Washer 7/16" ZN MED
23	S-7332	Hex Nut 7/16"-14 YDP Grade 5
24	GK1309	12" x 1" 1 Belt Sheave
24	GK1321	12" x 1" 2 Belt Sheave
24	GK2544	15" x 1" 2 Belt Sheave
24	GK4643	12" x 1" 3 Belt Sheave
24	GK2545	15" x 1" 3 Belt Sheave
25	S-3727	Bolt, HHCS 3/8"-16 x 1-3/4" YDP Grade 8
26	GK2025	Shaft: Drive 1" O.D. x 10" Long
27	S-4513	Key, 1/4" x 1/4" x 2" Stock for Shaft
28	S-8251	Stover Nut 3/8"-16 ZN Grade C
29	GK2854	6" x 11' Discharge Flight
29	GK2855	6" x 16' Discharge Flight
29	GK2856	6" x 21' Discharge Flight
30	GK7082	6" x 0.065" x 9' Discharge Tube
30	GK7083	6" x 0.065" x 14' Discharge Tube
30	GK7084	6" x 0.065" x 19' Discharge Tube

8" Custom Auger Parts

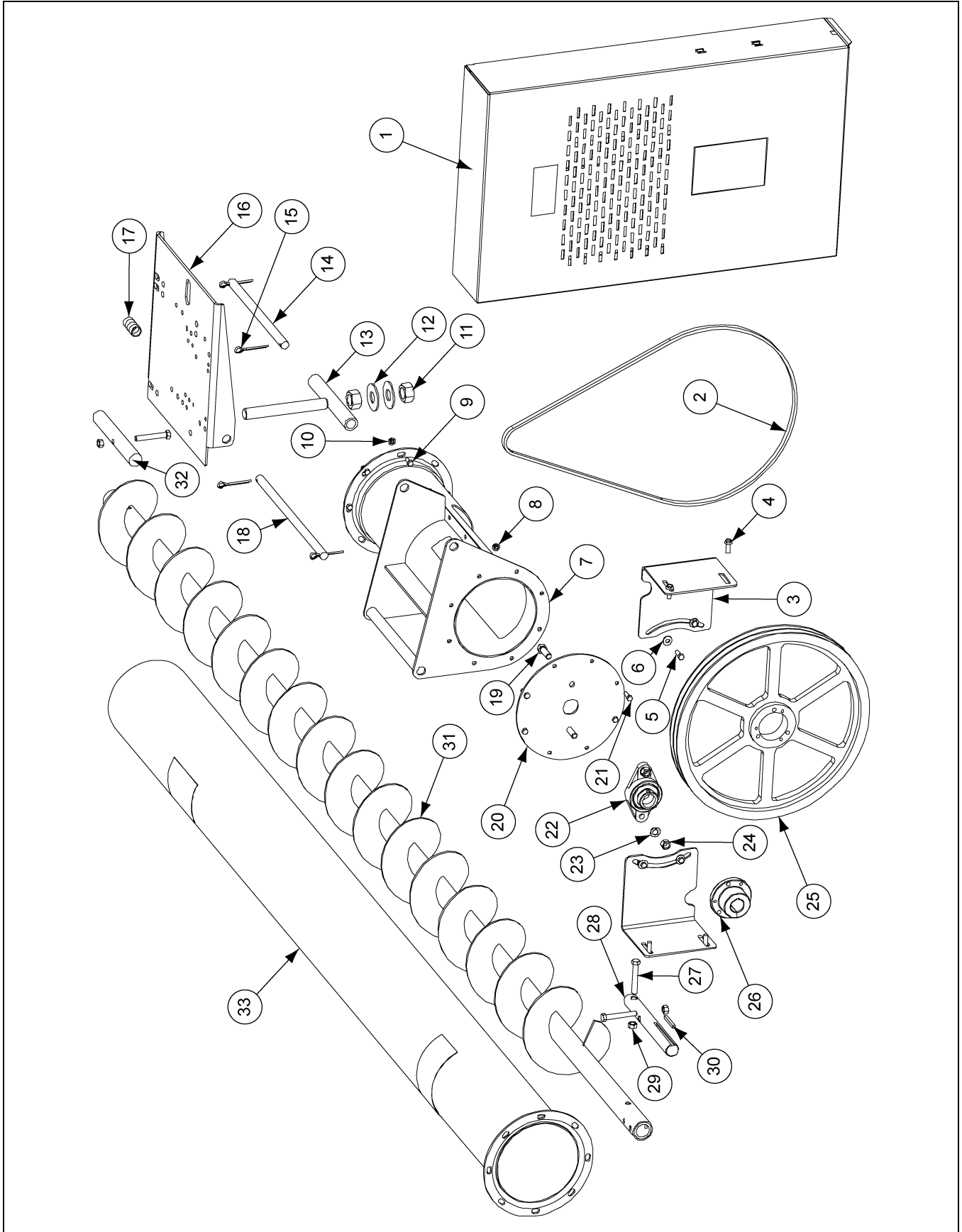

8" Custom Auger Parts List

Ref #	Part #	Description
1	GK7005	15" Belt Guard Assembly
1	GK7068	19" Belt Guard Galvanized Assembly
2	GK1952	V-Belt B50
2	GK1346	V-Belt B57
2	MHC00160	V-Belt B64
3	GK7006	8" x 15" Belt Guard Mounting Bracket
3	GK7100	8" x 19" Belt Guard Mounting Bracket
4	S-9065	Flange Bolt 3/8"-16 x 1" ZN Grade 5
5	S-1196	Bolt, HHCS 5/16"-18 x 1" ZN Grade 5
6	S-845	Flat Washer 5/16" USS SAE YDP Grade 2
7	GK6997	8" Horizontal Tube Assembly
8	S-3611	Flange Nut 5/16"-18 YDP Grade 2
9	S-275	Bolt, HH Bin 5/16"-18 x 3/4" YDP Grade 5
10	S-3611	Flange Nut 5/16"-18 YDP Grade 2
11	S-240	Hex Nut 1"-8 ZN Grade 5
12	S-7835	Flat Washer 1" I.D. x 2" O.D. ZN
13	GK7060	6" Motor Mount Adjustment Rod Weldment
14	GK7012	8" Motor Mount Adjustment Pivot Rod
15	S-6994	Cotter Pin 3/16" x 2" ZN Grade 2
16	GK6986-Y	8"-12" Motor Plate
17	GK7014	Drive Unit Pivot Spacer Tube
18	GK7013	8" Motor Mount Plate Pivot Rod
19	S-8760	Bolt, HHCS 1/2"-13 x 1-1/2" ZN Grade 5
20	GK6987-BS	8" Horizontal Bearing Plate - Bin Silver
21	S-1196	Bolt, HHCS 5/16"-18 x 1" ZN Grade 5
22	GK1330	Light Duty 1-1/4" Bore with Locking Collar 2 Hole Flange Bearing
23	S-236	Lock Washer 1/2" Zinc Plated
24	S-7510	Hex Nut 1/2"-13 ZN Grade 2
25	GK1335	12" x 1-1/4" 2 Belt Sheave
25	GK1869	15" x 1-1/4" 2 Belt Sheave
25	GK2567	18.4" x 1-1/4" 2 Belt Sheave
25	GK2234	15" x 1-1/4" 3 Belt Sheave
25	GK2570	18.4" x 1-1/4" 3 Belt Sheave
26	GCO7674	Bushing SK x 1-1/4" Bore
27	S-8316	Bolt, HHCS 7/16"-14 x 3" ZN YDP Grade 8
28	GK1331	Drive Shaft 1-1/4" O.D. x 10-1/2"
29	S-4513	Key, 1/4" x 1/4" x 2" Stock for Shaft
30	S-8317	Stover Nut 7/16"-14 ZN Grade C
31	GK2879	Discharge Flight 8" x 11' - System
31	GK2880	Discharge Flight 8" x 16' - System
31	GK2881	Discharge Flight 8" x 21' - System
32	GK1884	Intake Shaft 1-1/4" O.D. x 9"
33	GK7079	8" x 0.083" x 8' Discharge Tube
33	GK7080	8" x 0.083" x 13' Discharge Tube
33	GK7081	8" x 0.083" x 18' Discharge Tube

8" Internal Bearing Parts

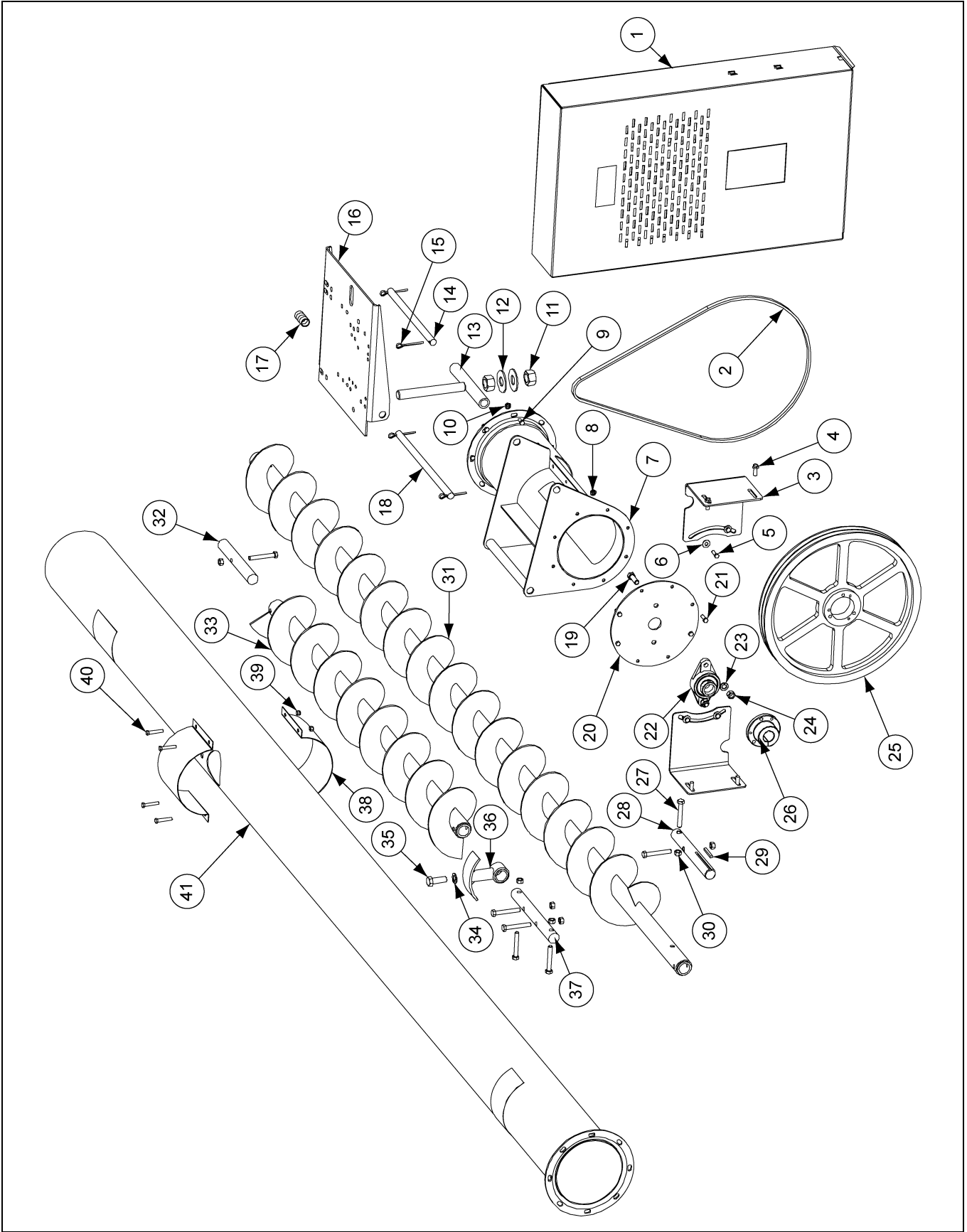

8" Internal Bearing Parts List

Ref #	Part #	Description
1	GK7005	15" Belt Guard Assembly
1	GK7068	19" Belt Guard Galvanized Assembly
2	GK1952	V-Belt B50
2	GK1346	V-Belt B57
2	MHC00160	V-Belt B64
3	GK7006	8" x 15" Belt Guard Mounting Bracket
3	GK7100	8" x 19" Belt Guard Mounting Bracket
4	S-9065	Flange Bolt 3/8"-16 x 1" ZN Grade 5
5	S-1196	Bolt, HHCS 5/16"-18 x 1" ZN Grade 5
6	S-845	Flat Washer 5/16" USS SAE YDP Grade 2
7	GK6997	8" Horizontal Tube Assembly
8	S-3611	Flange Nut 5/16"-18 YDP Grade 2
9	S-275	Bolt, HH Bin 5/16"-18 x 3/4" YDP Grade 5
10	S-3611	Flange Nut 5/16"-18 YDP Grade 2
11	S-240	Hex Nut 1"-8 ZN Grade 5
12	S-7835	Flat Washer 1" I.D. x 2" O.D. ZN
13	GK7060	6" Motor Mount Adjustment Rod Weldment
14	GK7012	8" Motor Mount Adjustment Pivot Rod
15	S-6994	Cotter Pin 3/16" x 2" ZN Grade 2
16	GK6986-Y	8"-12" Motor Plate
17	GK7014	Drive Unit Pivot Spacer Tube
18	GK7013	8" Motor Mount Plate Pivot Rod
19	S-8760	Bolt, HHCS 1/2"-13 x 1-1/2" ZN Grade 5
20	GK6987-BS	8" Horizontal Bearing Plate - Bin Silver
21	S-1196	Bolt, HHCS 5/16"-18 x 1" ZN Grade 5
22	GK1330	Light Duty 1-1/4" Bore with Locking Collar 2 Hole Flange Bearing
23	S-236	Lock Washer 1/2" Zinc Plated
24	S-7510	Hex Nut 1/2"-13 ZN Grade 2
25	GK1335	12" x 1-1/4" 2 Belt Sheave
25	GK1869	15" x 1-1/4" 2 Belt Sheave
25	GK2567	18.4" x 1-1/4" 2 Belt Sheave
25	GK2234	15" x 1-1/4" 3 Belt Sheave
25	GK2570	18.4" x 1-1/4" 3 Belt Sheave
26	GC07674	Bushing SK x 1-1/4" Bore
27	S-8316	Bolt, HHCS 7/16"-14 x 3" ZN YDP Grade 8
28	GK1331	Drive Shaft 1-1/4" O.D. x 10-1/2"
29	S-4513	Key, 1/4" x 1/4" x 2" Stock for Shaft
30	S-8317	Stover Nut 7/16"-14 ZN Grade C
31	GK3735	8" x 10' 10-1/2" Discharge Flight
32	GK1884	Intake Shaft 1-1/4" O.D. x 9"
33	GK4349	8" x 4' 9-3/8" Extension Flight
33	GK3736	8" x 9' 9-3/4" Extension Flight
34	S-3208	5/8" Lock Washer
35	S-7886	Bolt, HHCS 5/8"-11 x 1-3/4" YDP Grade 8
36	GC06394	8" Hange Bearing Assembly
37	GK1736	1-1/4" O.D. x 11-1/2" Connecting Shaft
38	GK3669	Inspection Cover Hole Large 8"
39	S-7382	Nylock Nut 5/16"-18 ZN Grade 5
40	S-7149	Bolt, HHTB 5/16"-18 x 1-3/4" ZN Grade 5
41	GK7093	8" x 0.083" x 13' IB Discharge Tube
41	GK7094	8" x 0.083" x 18' IB Discharge Tube

10" Custom Auger Parts

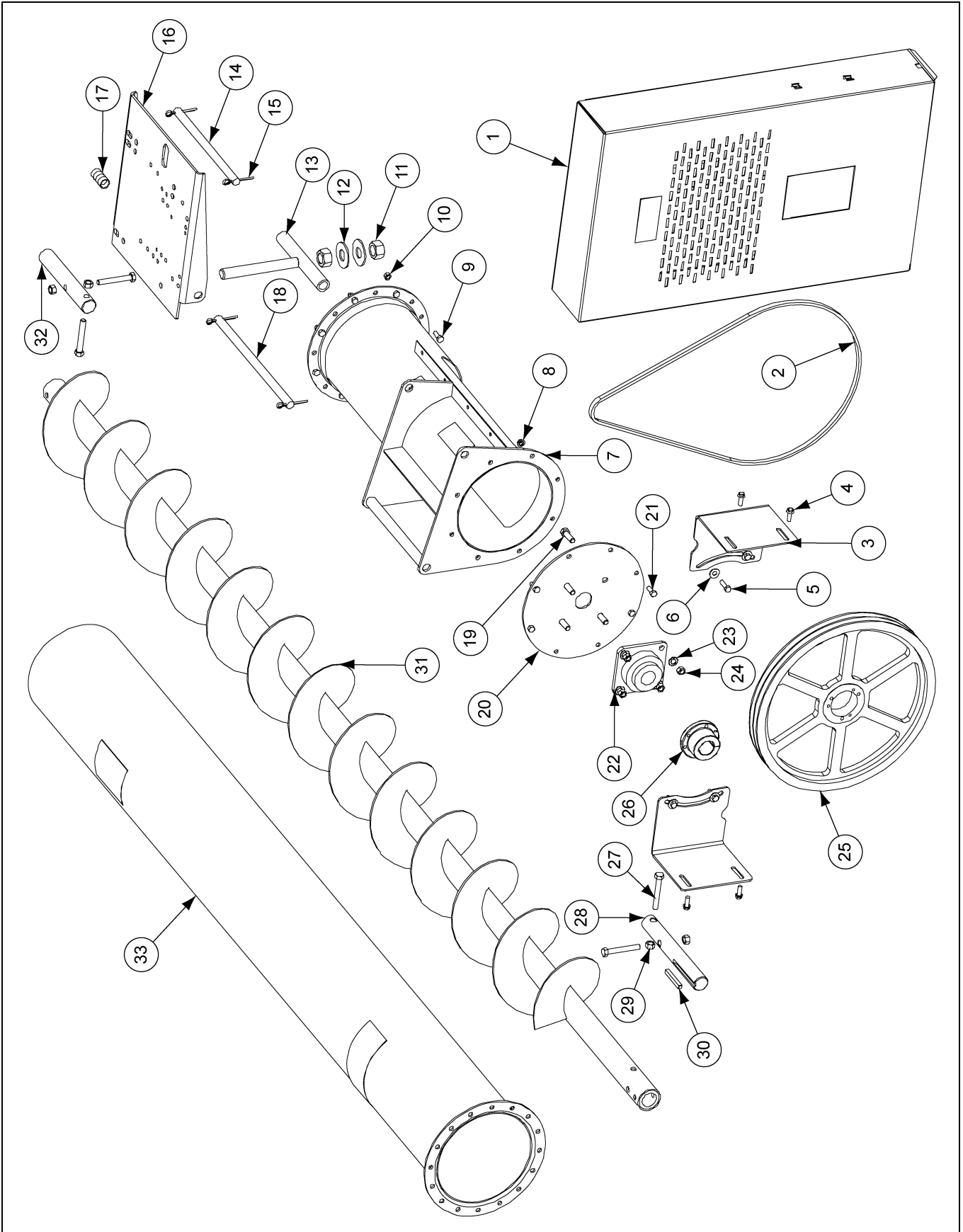

10" Custom Auger Parts List

Ref #	Part #	Description
1	GK7005	15" Belt Guard Assembly
1	GK7068	19" Belt Guard Galvanized Assembly
2	GK1346	V-Belt B57
2	MHC00160	V-Belt B64
2	GK4441	V-Belt B60
3	GK7018	10" x 15" Belt Guard Mounting Bracket
3	GK7101	10" x 19" Belt Guard Mounting Bracket
4	S-9065	Flange Bolt 3/8"-16 x 1" ZN Grade 5
5	S-2071	Bolt, HHCS 3/8"-16 x 1-1/4" ZN Grade 5
6	S-248	Flat Washer 3/8" 7/16" I.D. x 1" O.D. YDP
7	GK6998	10" Horizontal Tube Assembly
8	S-968	Flange Nut 3/8"-16 ZN Grade 5
9	S-7520	Bolt, HHCS 3/8"-16 x 1" ZN Grade 2
10	S-456	Hex Nut 3/8"-16 YDP Grade 5
11	S-240	Hex Nut 1"-8 ZN Grade 5
12	S-7835	Flat Washer 1" I.D. x 2" O.D. ZN
13	GK6942	8" Motor Mount Adjustment Rod Weldment
14	GK7012	8" Motor Mount Adjustment Pivot Rod
15	S-6994	Cotter Pin 3/16" x 2" ZN Grade 2
16	GK6986-Y	8"-12" Motor Plate
17	GK7014	Drive Unit Pivot Spacer Tube
18	GK7013	8" Motor Mount Plate Pivot Rod
19	S-8760	Bolt, HHCS 1/2"-13 x 1-1/2" ZN Grade 5
20	GK7017-BS	10" Horizontal Bearing Plate - Bin Silver
21	S-7469	Bolt, HHCS 3/8"-16 x 1" ZN Grade 5
22	GK1343	Light Duty 1-1/2" Bore with Locking Collar 4 Hole FS Style Flange Bearing
23	S-236	Lock Washer, 1/2" Zinc Plated
24	S-7510	Hex Nut 1/2"-13 ZN Grade 2
25	GK1345	15" x 1-1/2" 2 Belt Sheave
25	GK2567	18.4" x 1-1/4" 2 Belt Sheave
25	GK1304	15" x 1-1/2" 3 Belt Sheave
25	GK2570	18.4" x 1-1/4" 3 Belt Sheave
26	GK4248	18.4" Sheave Bushing
26	D03-0264	15" 4 Belt Sheave Bushing
27	S-8314	Bolt, HHCS 1/2"-13 x 3-1/2" YDP Grade 8
28	GK1289	1-1/2" O.D. x 12-1/2" Drive Shaft
29	S-9181	Square Key 3/8" x 3"
30	S-8315	1/2"-13 Stover Nut
31	GK5143	10" x 11' x 3/16" Discharge Flight Weldment
31	GK5144	10" x 16' x 3/16" Discharge Flight Weldment
31	GK5130	10" x 21' x 3/16" Discharge Flight Weldment
32	GK2907	1-1/2" x 9-1/2" Intake Shaft
33	GK7095	10" x 0.109" x 7' 6" Discharge Tube
33	GK7096	10" x 0.109" x 12' 6" Discharge Tube
33	GK7097	10" x 0.109" x 17' 6" Discharge Tube

10" Internal Bearing Parts

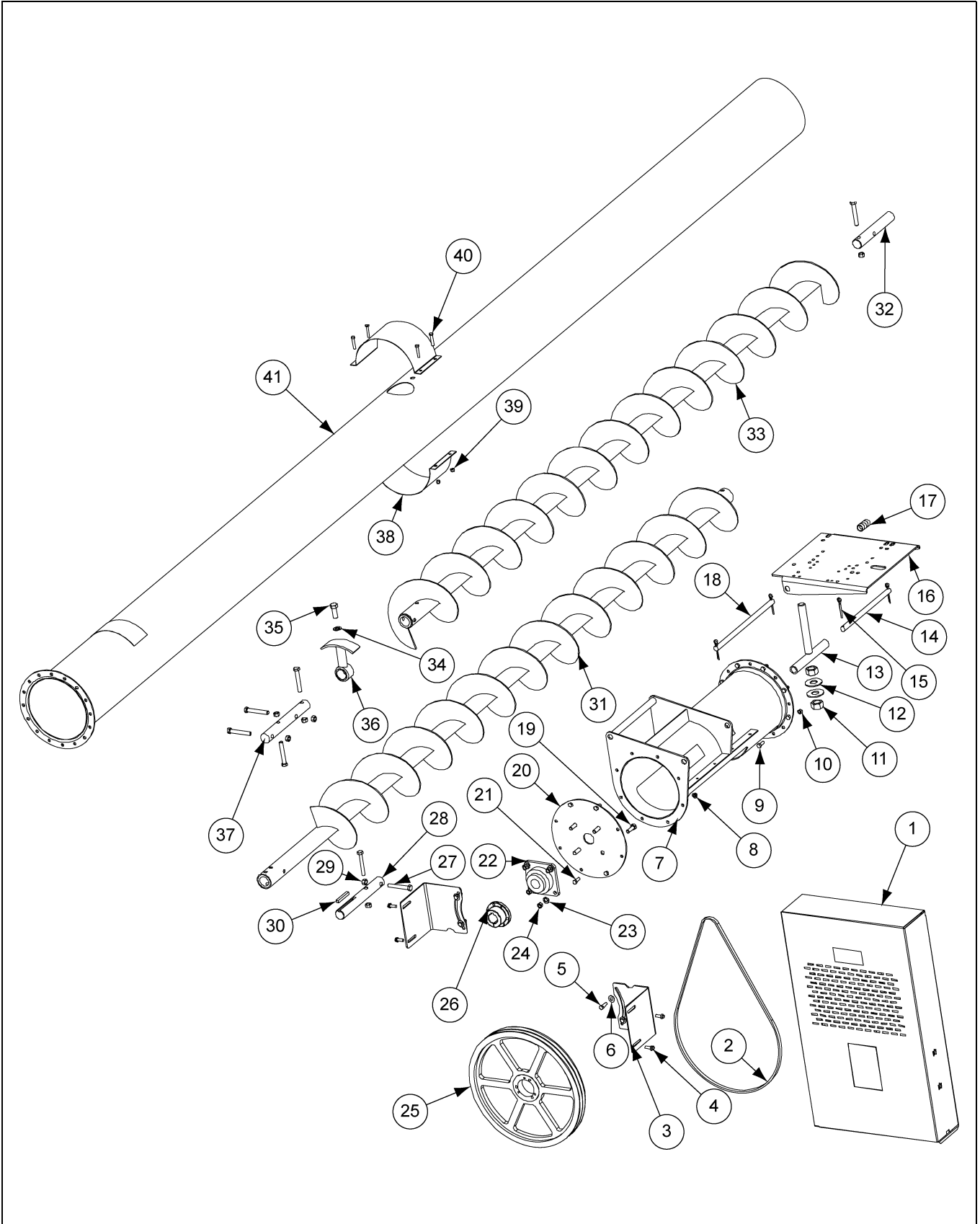

10" Internal Bearing Parts List

Ref #	Part #	Description
1	GK7005	15" Belt Guard Assembly
1	GK7068	19" Belt Guard Galvanized Assembly
2	GK1346	V-Belt B57
2	MHC00160	V-Belt B64
2	GK4441	V-Belt B60
3	GK7018	10" x 15" Belt Guard Mounting Bracket
3	GK7101	10" x 19" Belt Guard Mounting Bracket
4	S-9065	Flange Bolt 3/8"-16 x 1" ZN Grade 5
5	S-2071	Bolt, HHCS 3/8"-16 x 1-1/4" ZN Grade 5
6	S-248	Flat Washer 3/8" 7/16" I.D. x 1" O.D. YDP
7	GK6998	10" Horizontal Tube Assembly
8	S-968	Flange Nut 3/8"-16 ZN Grade 5
9	S-7520	Bolt, HHCS 3/8"-16 x 1" ZN Grade 2
10	S-456	Hex Nut 3/8"-16 YDP Grade 5
11	S-240	Hex Nut 1"-8 ZN Grade 5
12	S-7835	Flat Washer 1" I.D. x 2" O.D. ZN
13	GK6942	8" Motor Mount Adjustment Rod Weldment
14	GK7012	8" Motor Mount Adjustment Pivot Rod
15	S-6994	Cotter Pin 3/16" x 2" ZN Grade 2
16	GK6986-Y	8"-12" Motor Plate
17	GK7014	Drive Unit Pivot Spacer Tube
18	GK7013	8" Motor Mount Plate Pivot Rod
19	S-8760	Bolt, HHCS 1/2"-13 x 1-1/2" ZN Grade 5
20	GK7017-BS	10" Horizontal Bearing Plate - Bin Silver
21	S-7469	Bolt, HHCS 3/8"-16 x 1" ZN Grade 5
22	GK1343	Light Duty 1-1/2" Bore with Locking Collar 4 Hole FS Style Flange Bearing
23	S-236	Lock Washer 1/2" Zinc Plated
24	S-7510	Hex Nut 1/2"-13 ZN Grade 2
25	GK1345	15" x 1-1/2" 2 Belt Sheave
25	GK2567	18.4" x 1-1/4" 2 Belt Sheave
25	GK1304	15" x 1-1/2" 3 Belt Sheave
25	GK2570	18.4" x 1-1/4" 3 Belt Sheave
26	GK4248	18.4" Sheave Bushing
26	D03-0264	15" 4 Belt Sheave Bushing
27	S-8314	Bolt, HHCS 1/2"-13 x 3-1/2" YDP Grade 8
28	GK1289	1-1/2" O.D. x 12-1/2" Drive Shaft
29	S-9181	Square Key 3/8" x 3"
30	S-8315	1/2"-13 Stover Nut
31	GK5143	10" x 11' x 3/16" Discharge Flight Weldment
32	GK2907	1-1/2" x 9-1/2" Intake Shaft
33	GK3708	10" x 4' 9-15/16" Extension Flight
33	GK3706	10" x 9' 9-3/4" Extension Flight
34	S-3208	5/8" Lock Washer
35	S-7886	Bolt, HHCS 5/8"-11 x 1-3/4" YDP Grade 8
36	GC06396	10" Hange Bearing Assembly
37	GK1951	Connecting Shaft 1-1/2" O.D. x 11-1/2"
38	GK3670	10" Inspection Cover
39	S-7382	Nylock Nut 5/16"-18 ZN Grade 5
40	S-7149	Bolt, HHTB 5/16"-18 x 1-3/4" ZN Grade 5
41	GK7098	10" x 0.109" x 12' 6" IB Discharge Tube
41	GK7099	10" x 0.109" x 17' 6" IB Discharge Tube

12" Custom Auger Parts

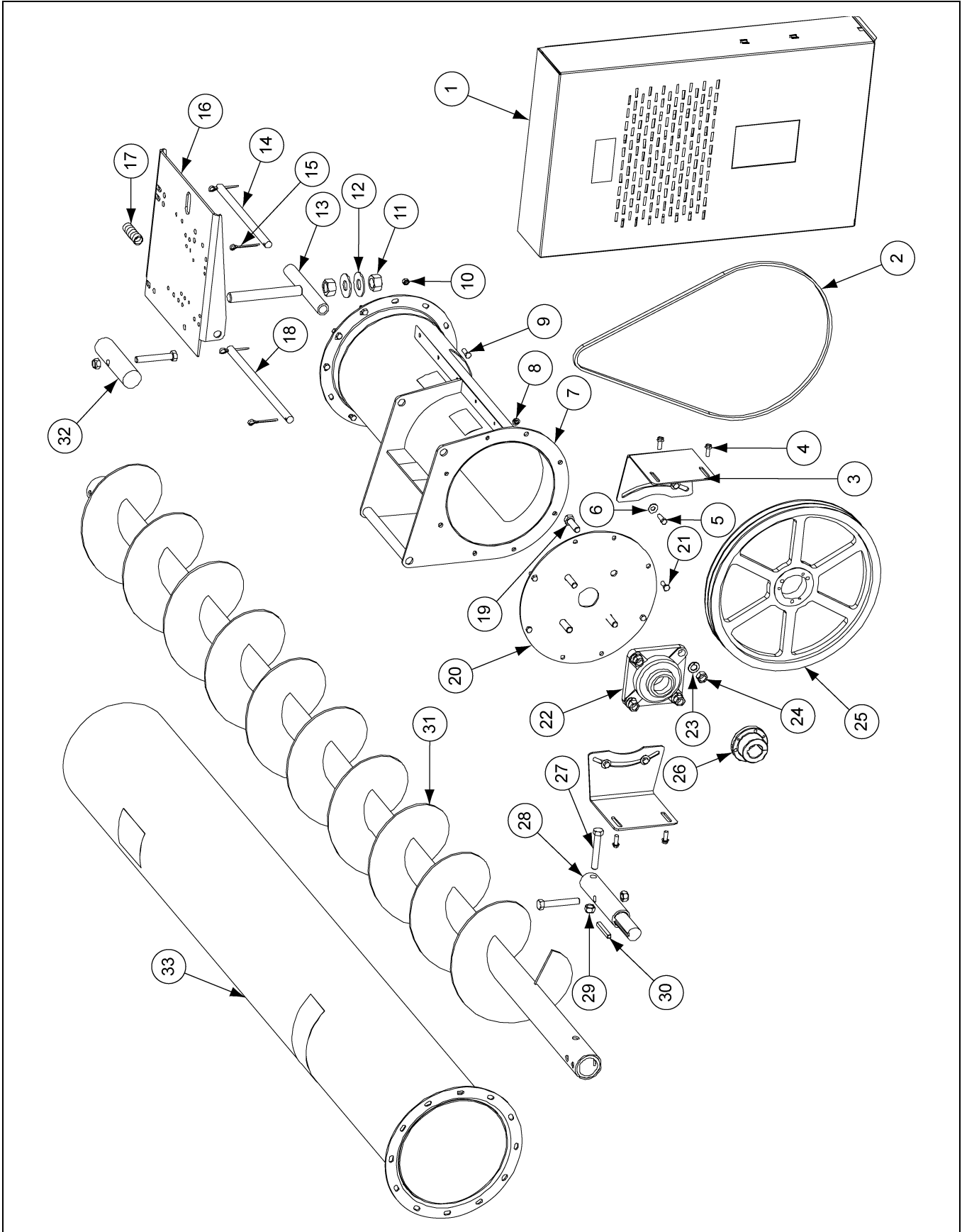

12" Custom Auger Parts List

Ref #	Part #	Description
1	GK7068	19" Belt Guard Galvanized Assembly
2	GK4129	V-Belt B68
2	PT1172	V-Belt B73
3	GK7101	10" x 19" Belt Guard Mount Bracket
4	S-9065	Flange Bolt 3/8"-16 x 1" ZN Grade 5
5	S-2071	Bolt, HHCS 3/8"-16 x 1-1/4" ZN Grade 5
6	S-248	Flat Washer 3/8" 7/16" I.D. x 1" O.D. YDP
7	GK6999	12" Horizontal Tube Assembly
8	S-968	Flange Nut 3/8"-16 ZN Grade 5
9	S-7520	Bolt, HHCS 3/8"-16 x 1" ZN Grade 2
10	S-456	Hex Nut 3/8"-16 YDP Grade 5
11	S-240	Hex Nut 1"-8 ZN Grade 5
12	S-7835	Flat Washer 1" I.D. x 2" O.D. ZN
13	GK6942	8" Motor Mount Adjustment Rod Weldment
14	GK7012	8" Motor Mount Adjustment Pivot Rod
15	S-6994	Cotter Pin 3/16" x 2" ZN Grade 2
16	GK6986-Y	8"-12" Motor Plate
17	GK7014	Drive Unit Pivot Spacer Tube
18	GK7013	8" Motor Mount Plate Pivot Rod
19	S-8399	Bolt, HHTB 5/8"-11 x 2" ZN Grade 5
20	GK7064-BS	12" Horizontal Bearing Plate - Bin Silver
21	S-7469	Bolt, HHCS 3/8"-16 x 1" ZN Grade 5
22	GK2004	Light Duty 2" Bore with Locking Collar 4 Hole Flange Bearing
23	S-3208	5/8" Lock Washer
24	S-4110	Hex Nut 5/8"-11 ZN Grade 5
25	GK2567	18.4" x 1-1/4" 2 Belt Sheave
25	GK2570	18.4" x 1-1/4" 3 Belt Sheave
25	GK3541	15" 4 Belt Sheave
26	GK4248	18.4" Sheave Bushing
26	D03-0264	15" 4 Belt Sheave Bushing
27	S-7893	Bolt, HHCS 5/8"-11 x 4" YDP Grade 8
28	GK2006	2" O.D. x 12" 25 DG Drive Shaft
29	S-9181	Square Key 3/8" x 3"
30	S-8606	5/8"-11 Stover Nut
31	GK5501	12" x 11' x 1/4" Discharge Flight Weldment
31	GK6567	12" x 16' Discharge Flight
31	GK5633	12" x 21' Discharge Flight
32	GK5313	2" x 7-3/4" Intake Shaft
33	GK7243	12" x 0.109" x 7' 6" Discharge Tube
33	GK7244	12" x 0.109" x 12' 6" Discharge Tube
33	GK7245	12" x 0.109" x 17' 6" Discharge Tube

12" Internal Bearing Parts

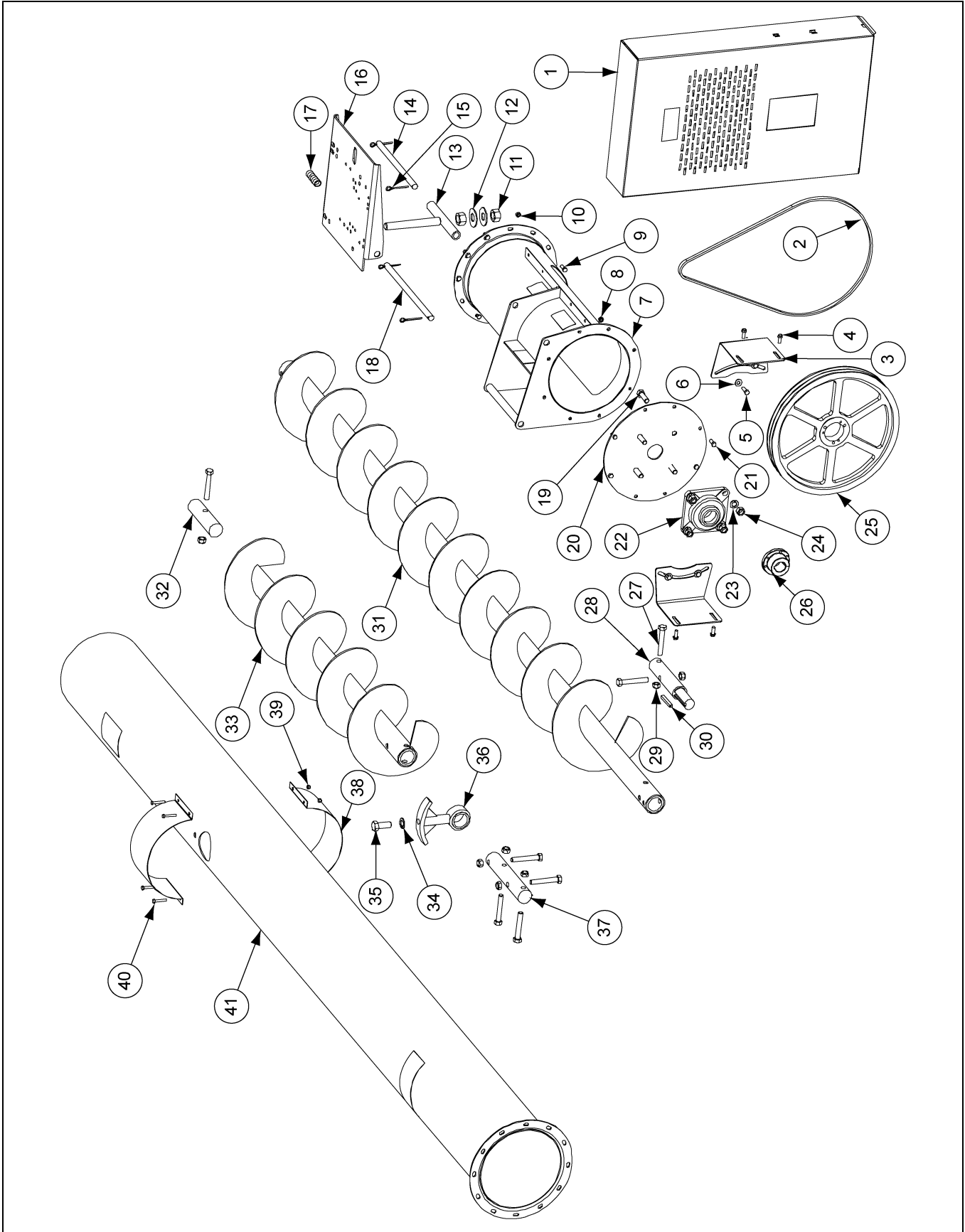

12" Internal Bearing Parts List

Ref #	Part #	Description
1	GK7068	19" Belt Guard Galvanized Assembly
2	GK4129	V-Belt B68
2	PT1172	V-Belt B73
3	GK7101	10" x 19" Belt Guard Mount Bracket
4	S-9065	Flange Bolt 3/8"-16 x 1" ZN Grade 5
5	S-2071	Bolt, HHCS 3/8"-16 x 1-1/4" ZN Grade 5
6	S-248	Flat Washer 3/8" 7/16" I.D. x 1" O.D. YDP
7	GK6999	12" Horizontal Tube Assembly
8	S-968	Flange Nut 3/8"-16 ZN Grade 5
9	S-7520	Bolt, HHCS 3/8"-16 x 1" ZN Grade 2
10	S-456	Hex Nut 3/8"-16 YDP Grade 5
11	S-240	Hex Nut 1"-8 ZN Grade 5
12	S-7835	Flat Washer 1" I.D. x 2" O.D. ZN
13	GK6942	8" Motor Mount Adjustment Rod Weldment
14	GK7012	8" Motor Mount Adjustment Pivot Rod
15	S-6994	Cotter Pin 3/16" x 2" ZN Grade 2
16	GK6986-Y	8"-12" Motor Plate
17	GK7014	Drive Unit Pivot Spacer Tube
18	GK7013	8" Motor Mount Plate Pivot Rod
19	S-8399	Bolt, HHTB 5/8"-11 x 2" ZN Grade 5
20	GK7064-BS	12" Horizontal Bearing Plate - Bin Silver
21	S-7469	Bolt, HHCS 3/8"-16 x 1" ZN Grade 5
22	GK2004	Light Duty 2" Bore with Locking Collar 4 Hole Flange Bearing
23	S-3208	5/8" Lock Washer
24	S-4110	Hex Nut 5/8"-11 ZN Grade 5
25	GK2567	18.4" x 1-1/4" 2 Belt Sheave
25	GK2570	18.4" x 1-1/4" 3 Belt Sheave
25	GK3541	15" 4 Belt Sheave
26	GK4248	18.4" Sheave Bushing
26	D03-0264	15" 4 Belt Sheave Bushing
27	S-7893	Bolt, HHCS 5/8"-11 x 4" YDP Grade 8
28	GK2006	2" O.D. x 12" 25 DG Drive Shaft
29	S-9181	Square Key 3/8" x 3"
30	S-8606	5/8"-11 Stover Nut
31	GK5501	12" x 11' x 1/4" Discharge Flight Weldment
32	GK5313	2" x 7-3/4" Intake Shaft
33	GK5566	12" x 4' 9-3/4" Extension Flight
33	GK4482	12" x 9' 9-3/4" Extension Flight
34	S-233	3/4" Lock Washer
35	S-869	Bolt, HHCS 3/4"-10 x 2" YDP Grade 8
36	GC06398	12" Hange Bearing Assembly
37	GK2222	2" x 11-1/2" Connecting Shaft
38	GK5599	12" Inspection Cover
39	S-7382	Nylock Nut 5/16"-18 ZN Grade 5
40	S-7149	Bolt, HHTB 5/16"-18 x 1-3/4" ZN Grade 5
41	GK7249	12" x 0.109" x 12' 6" IB Discharge Tube
41	GK7250	12" x 0.109" x 17' 6" IB Discharge Tube

6" Roof Augers Parts

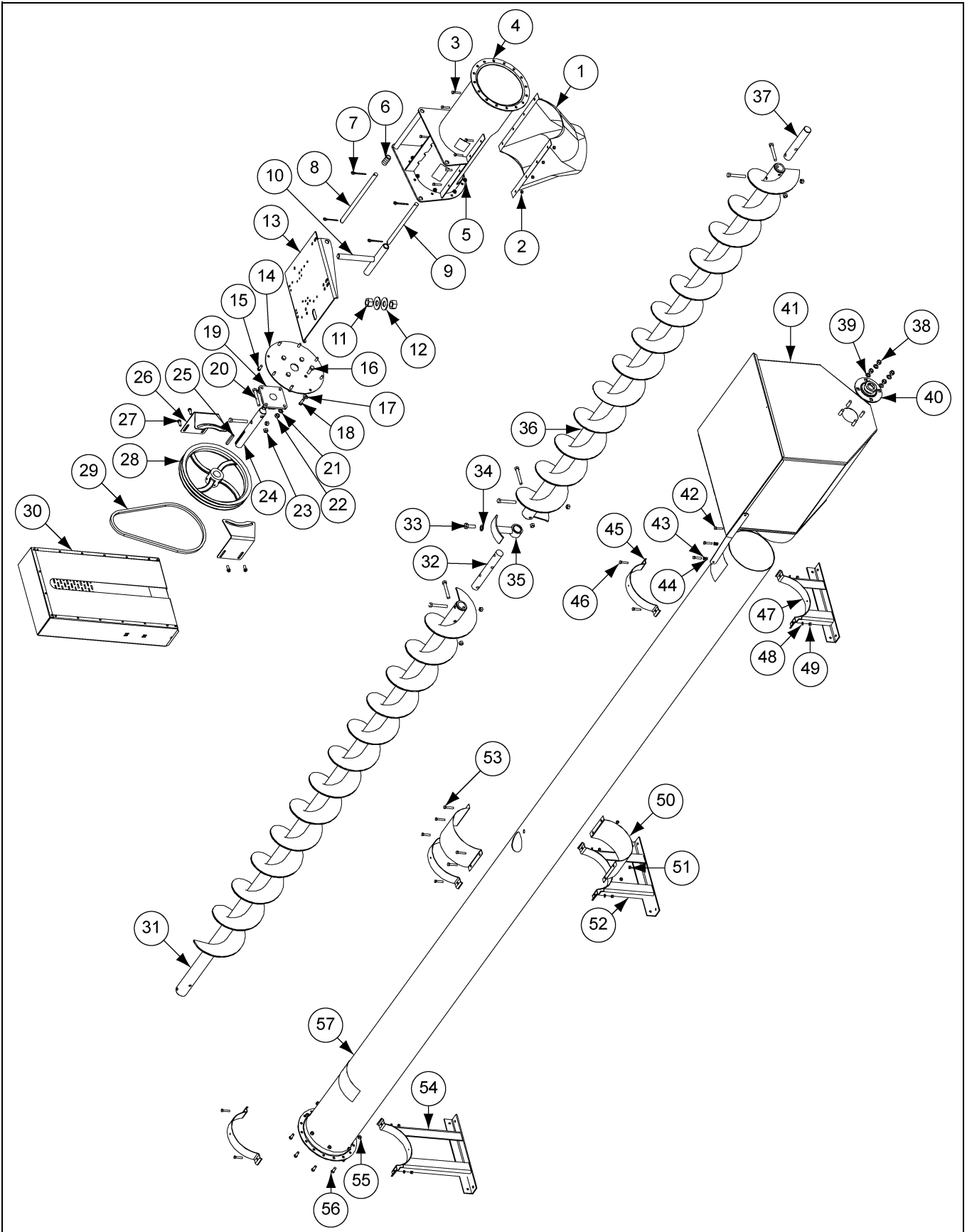

6" Roof Auger Parts List

Ref #	Part #	Description
1	GK7173	Discharge Spout, 6" x 90°
2	S-7382	Nylock Nut 5/16"-18 ZN Grade 5
3	S-2741	Bolt, HHCS 5/16"-18 x 1-1/2" ZN Grade 5
4	GK6996	6" Horizontal Tube Assembly
5	S-3611	Flange Nut 5/16"-18 YDP Grade 2
6	GK7014	Drive Unit Pivot Spacer Tube
7	S-6994	Cotter Pin 3/16" x 2" ZN Grade 2
8	GK7058	6" Motor Mount Plate Pivot Rod
10	GK7060	6" Motor Mount Adjustment Rod Weldment
11	S-3234	Motor Mount Adjuster 3/4"-10 Nut
12	S-866	Flat Washer 3/4" USS ZN Grade 2
13	GK7052-Y	6" Motor Plate
14	GK7061-BS	6" Horizontal Bearing Plate - Bin Silver
15	S-1196	Bolt, HHCS 5/16"-18 x 1" ZN Grade 5
16	S-7837	Bolt, HHCS 7/16"-14 x 1-1/2" ZN Grade 5
17	S-845	Flat Washer 5/16" USS SAE YDP Grade 2
18	S-1196	Bolt, HHCS 5/16"-18 x 1" ZN Grade 5
19	GK1049	Light Duty 1" Bore 2 Hole Flange with Locking Collar Bearing
20	S-7687	Flight Connecting 3/8"-16 x 2" Grade 8 Hex Bolt
21	S-7014	Split Lock Washer 7/16" ZN MED
22	S-7332	Hex Nut 7/16"-14 YDP Grade 5
23	S-8251	Stover Nut 3/8"-16 ZN Grade C
24	GK2025	Shaft: Drive 1" O.D. x 10" Long
25	S-4513	Key, 1/4" x 1/4" x 2" Stock for Shaft
26	GK7062	6" Belt Guard Mounting Bracket
27	S-9065	Flange Bolt 3/8"-16 x 1" ZN Grade 5
28	GK1321	12" x 1" 2 Belt Sheave
29	GK1323	V-Belt B48
30	GK7005	15" Belt Guard Assembly
31	GK2854	6" x 11' Discharge Flight
31	GK2855	6" x 16' Discharge Flight
31	GK2856	6" x 21' Discharge Flight
37	GK1117	Shaft: Intake 1" Diameter x 7"
38	S-396	Hex Nut 5/16"-18 YDP Grade 2
39	S-1147	Split Lock Washer 5/16" ZN
40	GK1583	Intake 1" Bearing with 3 Hole Flangette
41	GK3995	Hopper
42	S-1146	Bolt, HHCS 5/16"-18 x 1" ZN Grade 2
43	S-1147	Split Lock Washer 5/16" ZN
44	S-396	Hex Nut 5/16"-18 YDP Grade 2
45	GK1053	Support Stand 6" x 2" 12 Gauge Half Band
46	S-2741	Bolt, HHCS 5/16"-18 x 1-1/2" ZN Grade 5
47	GK7297-Y	Support Stand Short
48	S-1147	Split Lock Washer 5/16" ZN
49	S-396	Hex Nut 5/16"-18 YDP Grade 2
52	GK7298-Y	Support Stand Medium
54	GK7299-Y	Support Stand Tall
55	S-3611	Flange Nut 5/16"-18 YDP Grade 2
56	S-275	Bolt, HH Bin 5/16"-18 x 3/4" YDP Grade 5
57	GK7082	6" x 0.065" x 9' Discharge Tube
57	GK7083	6" x 0.065" x 14' Discharge Tube
57	GK7084	6" x 0.065" x 19' Discharge Tube

8" Roof Augers Parts

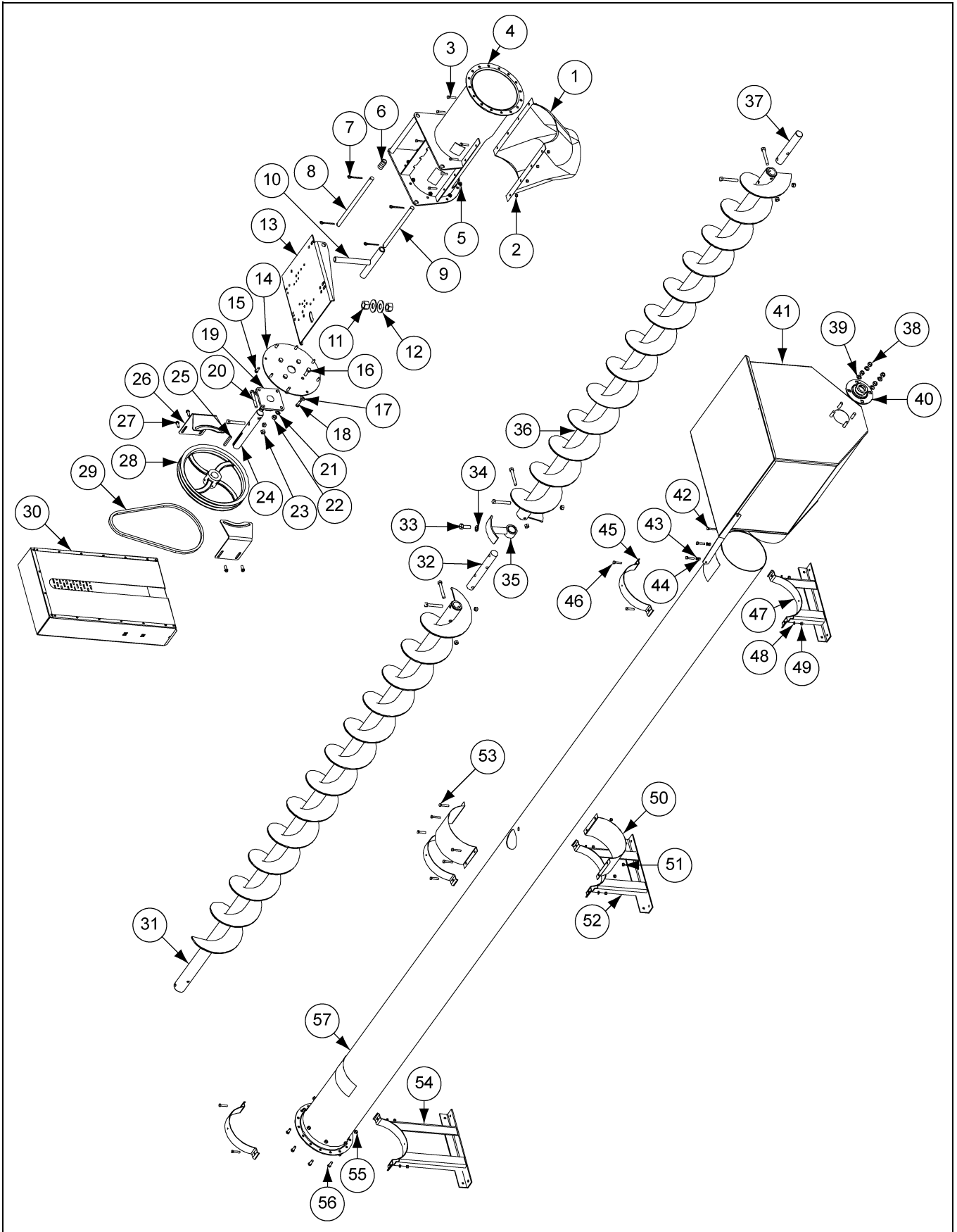

8" Roof Auger Parts List

Ref #	Part #	Description and System
1	GK3394	Spout, 8" 90° Weldment
2	S-7382	Nylock Nut 5/16"-18 ZN Grade 5
3	S-2741	Bolt, HHCS 5/16"-18 x 1-1/2" ZN Grade 5
4	GK6997	8" Horizontal Tube Assembly
5	S-3611	Flange Nut 5/16"-18 YDP Grade 2
6	GK7014	Drive Unit Pivot Spacer Tube
7	S-6994	Cotter Pin 3/16" x 2" ZN Grade 2
8	GK7013	8" Motor Mount Plate Pivot Rod
9	GK7012	8" Motor Mount Adjustment Pivot Rod
10	GK6942	8" Motor Mount Adjustment Rod Weldment
11	S-240	Hex Nut 1"-8 ZN Grade 5
12	S-7835	Flat Washer 1" I.D. x 2" O.D. ZN
13	GK6986-Y	8"-12" Motor Plate
14	GK6987-BS	8" Horizontal Bearing Plate - Bin Silver
15	S-1196	Bolt, HHCS 5/16"-18 x 1" ZN Grade 5
16	S-8760	Bolt, HHCS 1/2"-13 x 1-1/2" ZN Grade 5
17	S-845	Flat Washer 5/16" USS SAE YDP Grade 2
18	S-1196	Bolt, HHCS 5/16"-18 x 1" ZN Grade 5
19	GK1330	Light Duty 1-1/4" Bore with Locking Collar 2 Hole Flange Bearing
20	S-8316	Bolt, HHCS 7/16"-14 x 3" ZN YDP Grade 8
21	S-236	Lock Washer 1/2" Zinc Plated
22	S-3729	1/2"-13 Hex Nut YDP Grade 5
23	S-8317	Stover Nut 7/16"-14 ZN Grade C
24	GK1331	Drive Shaft 1-1/4" O.D. x 10-1/2"
25	S-4513	Key, 1/4" x 1/4" x 2" Stock for Shaft
26	GK7006	8" x 15" Belt Guard Mounting Bracket
27	S-9065	Flange Bolt 3/8"-16 x 1" ZN Grade 5
28	GK1335	12" x 1-1/4" 2 Belt Sheave
29	GK1952	V-Belt B50
30	GK7005	15" Belt Guard Assembly
31	GK2879	Discharge Flight 8" x 11' - System
31	GK2880	Discharge Flight 8" x 16' - System
31	GK2881	Discharge Flight 8" x 21' - System
37	GK1884	Intake Shaft 1-1/4" O.D. x 9"
38	S-456	Hex Nut 3/8"-16 YDP Grade 5
39	S-1054	Intake Bearing 3/8" Lock Washer
40	GK7221	Intake 1-1/4" Bearing with 3 Hole Flangette
41	GK3996	Hopper
42	S-1146	Bolt, HHCS 5/16"-18 x 1" ZN Grade 2
43	S-1147	Split Lock Washer 5/16" ZN
44	S-396	Hex Nut 5/16"-18 YDP Grade 2
45	GK1055	Half Band 8" x 2" 12 Gauge Galvanized
46	S-2741	Bolt, HHCS 5/16"-18 x 1-1/2" ZN Grade 5
47	GK7300-Y	Support Stand Short
48	S-1147	Split Lock Washer 5/16" ZN
49	S-396	Hex Nut 5/16"-18 YDP Grade 2
52	GK7301-Y	Support Stand Medium
54	GK7302-Y	Support Stand Tall
55	S-3611	Flange Nut 5/16"-18 YDP Grade 2
56	S-275	Bolt, HH Bin 5/16"-18 x 3/4" YDP Grade 5
57	GK7079	8" x 0.083" x 8' Discharge Tube
57	GK7080	8" x 0.083" x 13' Discharge Tube
57	GK7081	8" x 0.083" x 18' Discharge Tube

10" Roof Augers Parts

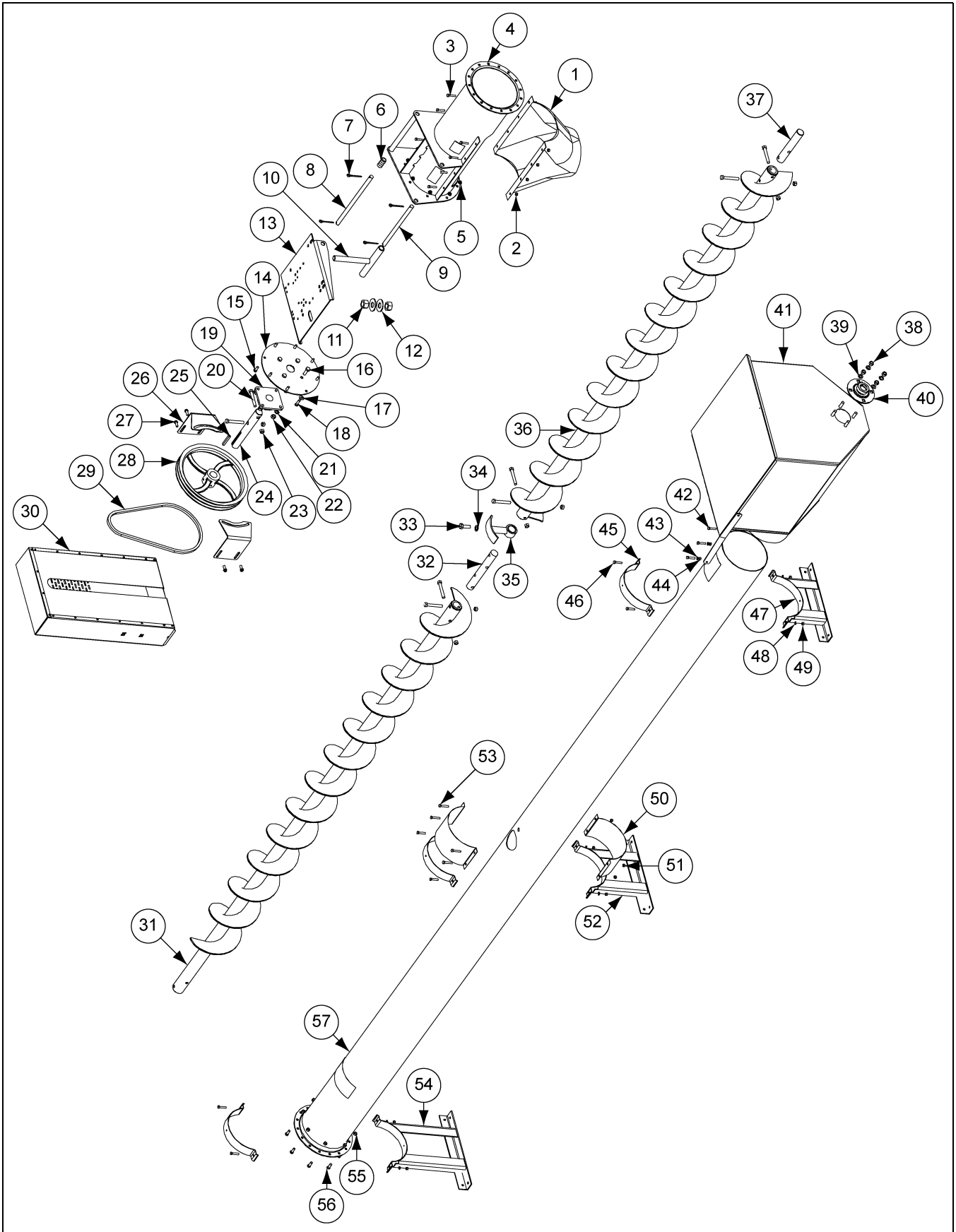

10" Roof Auger Parts List

Ref #	Part #	Description and System
1	GK3397	90° Spout
2	S-7382	Nylock Nut 5/16"-18 ZN Grade 5
3	S-2741	Bolt, HHCS 5/16"-18 x 1-1/2" ZN Grade 5
4	GK6998	10" Horizontal Tube Assembly
5	S-968	Flange Nut 3/8"-16 ZN Grade 5
6	GK7014	Drive Unit Pivot Spacer Tube
7	S-6994	Cotter Pin 3/16" x 2" ZN Grade 2
8	GK7013	8" Motor Mount Plate Pivot Rod
9	GK7012	8" Motor Mount Adjustment Pivot Rod
10	GK6942	8" Motor Mount Adjustment Rod Weldment
11	S-240	Hex Nut 1"-8 ZN Grade 5
12	S-7835	Flat Washer 1" I.D. x 2" O.D. ZN
13	GK6986-Y	8"-12" Motor Plate
14	GK7017-BS	10" Horizontal Bearing Plate - Bin Silver
15	S-7469	Bolt, HHCS 3/8"-16 x 1" ZN Grade 5
16	S-8760	Bolt, HHCS 1/2"-13 x 1-1/2" ZN Grade 5
17	S-248	Flat Washer 3/8" 7/16" I.D. x 1" O.D. YDP
18	S-2071	Bolt, HHCS 3/8"-16 x 1-1/4" ZN Grade 5
19	GK1343	Light Duty 1-1/2" Bore with Locking Collar 4 Hole FS Style Flange Bearing
20	S-8314	Bolt, HHCS 1/2"-13 x 3-1/2" YDP Grade 8
21	S-236	Lock Washer 1/2" Zinc Plated
22	S-3729	1/2"-13 Hex Nut YDP Grade 5
23	S-8315	1/2"-13 Stover Nut
24	GK1289	1-1/2" O.D. x 12-1/2" Drive Shaft
25	S-9181	Square Key 3/8" x 3"
26	GK7018	10" x 15" Belt Guard Mounting Bracket
27	S-9065	Flange Bolt 3/8"-16 x 1" ZN Grade 5
28	GK1345	15" x 1-1/2" 2 Belt Sheave
29	GK1346	V-Belt B57
30	GK7005	15" Belt Guard Assembly
31	GK5143	10" x 11' x 3/16" Discharge Flight Weldment
32	GK1951	Connecting Shaft 1-1/2" O.D. x 11-1/2"
33	S-7886	Bolt, HHCS 5/8"-11 x 1-3/4" YDP Grade 8
34	S-3208	5/8" Lock Washer
35	GC06396	10" Hange Bearing Assembly
36	GK3708	10" x 4' 9-15/16" Extension Flight
36	GK3706	10" x 9' 9-3/4" Extension Flight
37	GK2907	1-1/2" x 9-1/2" Intake Shaft
38	S-3729	1/2"-13 Hex Nut YDP Grade 5
39	S-236	Lock Washer 1/2" Zinc Plated
40	GK5653	Intake 1-1/2" Bearing with 3 Hole Flangette
41	GK4127	Hopper
42	S-2741	Bolt, HHCS 5/16"-18 x 1-1/2" ZN Grade 5
43	S-1147	Split Lock Washer 5/16" ZN
44	S-396	Hex Nut 5/16"-18 YDP Grade 2
45	GK1057	Support Stand 10" x 2" 12 Gauge Half Band
46	S-2741	Bolt, HHCS 5/16"-18 x 1-1/2" ZN Grade 5
47	GK7303-Y	Support Stand Short
48	S-1147	Split Lock Washer 5/16" ZN
49	S-396	Hex Nut 5/16"-18 YDP Grade 2
50	GK3670	10" Inspection Cover
51	S-7382	Nylock Nut 5/16"-18 ZN Grade 5
52	GK7304-Y	Support Stand Medium
53	S-7149	Bolt, HHTB 5/16"-18 x 1-3/4" ZN Grade 5
54	GK7305-Y	Support Stand Tall
55	S-456	Hex Nut 3/8"-16 YDP Grade 5
56	S-7520	Bolt, HHCS 3/8"-16 x 1" ZN Grade 2
57	GK7095	10" x 0.109" x 7' 6" Discharge Tube
57	GK7098	10" x 0.109" x 12' 6" IB Discharge Tube
57	GK7099	10" x 0.109" x 17' 6" IB Discharge Tube

10. Troubleshooting

Problem	Possible Cause	Solution
The auger is vibrating.	1. Damage can occur to the auger flighting, causing noise. Damage usually is caused from foreign material being run through the auger.	1. It may be necessary to remove the flighting for inspection.
	2. Drive belt may be overtightened, putting head stub and flight in a bind.	2. Loosen the drive belts.
Capacity is too low.	1. There may not be enough grain reaching the auger.	1. Make sure the intake has not bridged over, restricting flow. The flighting at the intake should be covered with grain for maximum capacity.
	2. The auger is moving too slowly.	2. Check the auger speed. Low capacity will result from speeds slower than recommended.
The auger plugs.	1. The auger may be "jamming" because too much grain is reaching the auger.	1. Use the control gates to decrease the amount of grain the auger is gathering.
	2. The grain may be wet.	2. If wet grain or other hard-to-move material is being augered, use a larger size motor than recommended for normal use.
	3. The auger may be jammed with foreign material.	3. Remove any foreign material in the auger.
	4. The motor may be too small or wired incorrectly.	4. Check wiring or consider using the next larger size motor.

GSI Group, LLC Limited Warranty

The GSI Group, LLC ("GSI") warrants products which it manufactures to be free of defects in materials and workmanship under normal usage and conditions for a period of 12 months after sale to the original end-user or if a foreign sale, 14 months from arrival at port of discharge, whichever is earlier. The end-user's sole remedy (and GSI's only obligation) is to repair or replace, at GSI's option and expense, products that in GSI's judgment, contain a material defect in materials or workmanship. Expenses incurred by or on behalf of the end-user without prior written authorization from the GSI Warranty Group shall be the sole responsibility of the end-user.

Warranty Extensions:

The Limited Warranty period is extended for the following products:

	Product	Warranty Period	
AP Fans and Flooring	Performer Series Direct Drive Fan Motor	3 Years	* Warranty prorated from list price: 0 to 3 years - no cost to end-user 3 to 5 years - end-user pays 25% 5 to 7 years - end-user pays 50% 7 to 10 years - end-user pays 75%
	All Fiberglass Housings	Lifetime	
	All Fiberglass Propellers	Lifetime	
AP and Cumberland	Flex-Flo/Pan Feeding System Motors	2 Years	
Cumberland Feeding/Watering Systems	Feeder System Pan Assemblies	5 Years **	** Warranty prorated from list price: 0 to 3 years - no cost to end-user 3 to 5 years - end-user pays 50%
	Feed Tubes (1-3/4" and 2.00")	10 Years *	
	Centerless Augers	10 Years *	
	Watering Nipples	10 Years *	
Grain Systems	Grain Bin Structural Design	5 Years	
Grain Systems Farm Fans Zimmerman	Portable and Tower Dryers	2 Years	† Motors, burner components and moving parts not included. Portable dryer screens included. Tower dryer screens not included.
	Portable and Tower Dryer Frames and Internal Infrastructure †	5 Years	

GSI further warrants that the portable and tower dryer frame and basket, excluding all auger and auger drive components, shall be free from defects in materials for a period of time beginning on the twelfth (12th) month from the date of purchase and continuing until the sixtieth (60th) month from the date of purchase (extended warranty period). During the extended warranty period, GSI will replace the frame or basket components that prove to be defective under normal conditions of use without charge, excluding the labor, transportation, and/or shipping costs incurred in the performance of this extended warranty.

Conditions and Limitations:

THERE ARE NO WARRANTIES THAT EXTEND BEYOND THE LIMITED WARRANTY DESCRIPTION SET FORTH ABOVE. SPECIFICALLY, GSI MAKES NO FURTHER WARRANTY OF ANY KIND, EXPRESS OR IMPLIED, INCLUDING, WITHOUT LIMITATION, WARRANTIES OF MERCHANTABILITY OR FITNESS FOR A PARTICULAR PURPOSE OR USE IN CONNECTION WITH: (I) PRODUCT MANUFACTURED OR SOLD BY GSI OR (II) ANY ADVICE, INSTRUCTION, RECOMMENDATION OR SUGGESTION PROVIDED BY AN AGENT, REPRESENTATIVE OR EMPLOYEE OF GSI REGARDING OR RELATED TO THE CONFIGURATION, INSTALLATION, LAYOUT, SUITABILITY FOR A PARTICULAR PURPOSE, OR DESIGN OF SUCH PRODUCTS.

GSI shall not be liable for any direct, indirect, incidental or consequential damages, including, without limitation, loss of anticipated profits or benefits. The sole and exclusive remedy is set forth in the Limited Warranty, which shall not exceed the amount paid for the product purchased. This warranty is not transferable and applies only to the original end-user. GSI shall have no obligation or responsibility for any representations or warranties made by or on behalf of any dealer, agent or distributor.

GSI assumes no responsibility for claims resulting from construction defects or unauthorized modifications to products which it manufactured. Modifications to products not specifically delineated in the manual accompanying the equipment at initial sale will void the Limited Warranty.

This Limited Warranty shall not extend to products or parts which have been damaged by negligent use, misuse, alteration, accident or which have been improperly/inadequately maintained. This Limited Warranty extends solely to products manufactured by GSI.

Prior to installation, the end-user has the responsibility to comply with federal, state and local codes which apply to the location and installation of products manufactured or sold by GSI.

This equipment shall be installed in accordance with the current installation codes and applicable regulations, which should be carefully followed in all cases. Authorities having jurisdiction should be consulted before installations are made.



**1004 E. Illinois St.
Assumption, IL 62510-0020
Phone: 1-217-226-4421
Fax: 1-217-226-4420
www.gsiag.com**



GSI is a worldwide brand of AGCO Corporation.