

Belt Guard Replacement Kit

Replaces 15" Black Plastic Belt Guard Used in:
6", 8" and 10" Horizontal and 25° Powerheads,
6", 8" and 10" Single-Drive Vertical Powerheads and
8" Double-Drive Vertical Powerheads

Installation Manual

PNEG-1550

Date: 03-26-07

G S I G R O U P



PNEG-1550

This manual is valid for the following Kits

Part #	Description
GK1454-68	6", 8" Drives
GK1454-10	10" Drives
GK1454-68SV	6", 8" Single-Drive Verticals
GK1454-10SV	10" Single-Drive Verticals
GK1454-8DV	8" Double-Drive Vertical, Horizontal Drive Only

Contents

Chapter 1 Introduction	4
Chapter 2 Safety	5
Safety Guidelines	5
Safety Instructions	6
Chapter 3 Safety Decals	10
Chapter 4 Installation	11
Chapter 5 Parts List	20
Replacement Belt Guard Components	20
Chapter 6 Note	21
Chapter 7 Warranty	22

1. INTRODUCTION

READ THIS MANUAL carefully to learn how to properly use and install equipment. Failure to do so could result in personal injury or equipment damage.

INSPECT the shipment immediately upon arrival. The Customer is responsible for ensuring that all quantities are correct. Report any damage or shortages by recording a detailed description on the Bill of Lading to justify the Customer's claim from the Transport Firm.

THIS MANUAL SHOULD BE CONSIDERED a permanent part of your equipment and should be easily accessible when needed.

WARRANTY is provided as part of the company's support program for customers who use and maintain their equipment as described in the manual. The warranty is explained on the warranty page located on the inside of the back cover.

This warranty provides you the assurance that the company will back its products where defects appear within the warranty period. Should the equipment be abused, or modified to change its performance beyond the factory specifications, the warranty will become void.

2. SAFETY

2.1 Safety Guidelines

This manual contains information that is important for you, the owner/operator, to know and understand. This information relates to protecting **personal safety** and **preventing equipment problems**. It is the responsibility of the owner/operator to inform anyone operating or working in the area of this equipment of these safety guidelines. To help you recognize this information, we use the symbols that are defined below. Please read the manual and pay attention to these sections. Failure to read this manual and its safety instructions is a misuse of the equipment and may lead to serious injury or death.



This is the safety alert symbol. It is used to alert you to potential personal injury hazards. Obey all safety messages that follow this symbol to avoid possible injury or death.



DANGER indicates an imminently hazardous situation which, if not avoided, will result in death or serious injury.



WARNING indicates a potentially hazardous situation which, if not avoided, could result in death or serious injury.



CAUTION indicates a potentially hazardous situation which, if not avoided, may result in minor or moderate injury.



CAUTION used without the safety alert symbol indicates a potentially hazardous situation which, if not avoided, may result in property damage.



NOTE indicates information about the equipment that you should pay special attention to.

2.2 Safety Instructions

GSI's principle concern is your safety and the safety of others associated with grain handling equipment. We want to keep you as a customer. This manual is to help you understand safe operating procedures and some problems which may be encountered by the operator and other personnel.

As owner and/or operator, it is your responsibility to know what requirements, hazards and precautions exist, and to inform all personnel associated with the equipment or in the area. Safety precautions may be required from the personnel. Avoid any alterations to the equipment. Such alterations may produce a very dangerous situation, where **SERIOUS INJURY** or **DEATH** may occur.

This equipment shall be installed in accordance with the current installation codes and applicable regulations which should be carefully followed in all cases. Authorities having jurisdiction should be consulted before installations are made.

Operate Unload Equipment Properly

Make sure ALL equipment is locked in position before operating.

NEVER start equipment until ALL persons are clear of the work area.

Be sure all operators are adequately rested and prepared to perform all functions of operating this equipment.

NEVER allow any person intoxicated or under the influence of alcohol or drugs to operate the equipment.

NEVER work alone.

Make sure someone is nearby who is aware of the proper shutdown sequence in the event of an accident or emergency.

ALWAYS think before acting. NEVER act impulsively around the equipment.

NEVER allow anyone inside a bin, truck or wagon which is being unloaded by an auger or conveyor. Flowing grain can trap and suffocate in seconds.

Use ample overhead lighting after sunset to light the work area.

Keep area around intake free of obstacles such as electrical cords, blocks, etc., that might trip workers.

NEVER drive, stand or walk under the equipment.

Use caution not to hit the auger when positioning the load.

ALWAYS lockout ALL power to the equipment when finished unloading a bin.



**Operate Unload
Equipment Safely**

Follow Safety Instructions

Carefully read all safety messages in this manual and on your machine safety signs. Keep signs in good condition. Replace missing or damaged safety signs. Be sure new equipment components and repair parts include the current safety signs. Replacement safety signs are available from the manufacturer.

Learn how to operate the machine and how to use controls properly. Do not let anyone operate without instruction.

Keep your machinery in proper working condition. Unauthorized modifications to the machine may impair the function and/or safety and affect machine life.

If you do not understand any part of this manual and need assistance, contact your dealer.

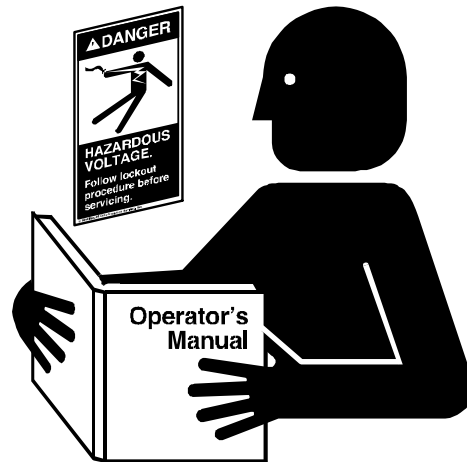

Read and Understand Manual

Install & Operate Electrical Equipment Properly

To avoid serious injury or death, stay away from unit and make sure everyone is clear of all augers before starting or operating the unit.

Electrical controls should be installed by a qualified electrician and must meet the standards set by the national electrical code and all local and state codes.

Disconnect and lock out all power sources before installing wires/cables or servicing equipment.

Do not operate electric motor equipped units until motors are properly grounded.

Disconnect power on electrical driven units before resetting motor overloads.

Do not repetitively stop and start the drive in order to free a plugged condition. Jogging the drive in this type of condition can damage the equipment.

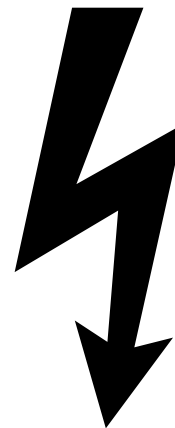

Electric Shock Hazard

Prepare for Emergencies

Be prepared if fire starts.

Keep a first aid kit and fire extinguisher handy.

Keep emergency numbers for doctors, ambulance service, hospital, and fire department near your telephone.

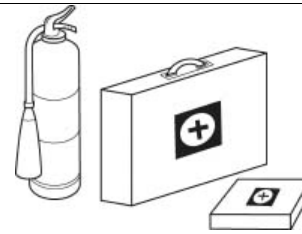

Keep Emergency Equipment Quickly Accessible.

Wear Protective Clothing

Wear close fitting clothing and safety equipment appropriate to the job.

Safety glasses should be worn at all times to protect eyes from debris.

Eye Protection

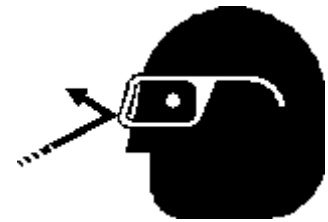

Wear gloves to protect your hands from sharp edges on plastic or steel parts.

Gloves



Wear steel toe boots to help protect your toes from falling debris.

Steel Toe Boots



A respirator may be needed if a hog house has poor ventilation. Waste fumes can be toxic.

Respirator



Remove all jewelry.

Tuck in any loose or dangling shoe strings.

Long hair should be tied up and back.

Wear hard hat to help protect your head.

Hard Hat



SAFETY 1st

***Replace missing guards and shields
FREE OF CHARGE!***

Our equipment is built to provide many years of dependable service to our customers through durable craftsmanship.

One of the most important aspects of our engineering is **SAFETY 1st** design throughout all product lines. Safety is NO ACCIDENT!

That is why we are implementing its **SAFETY 1st** program. Should you ever need guards, shields, safety decals, or owner/operator manuals, simply contact us, and we will supply you with them **FREE OF CHARGE!**

While it is our main goal to be the world leader in auger manufacturing, it is always our first priority to keep our customers safe.

If you need any of the above listed safety items or have safety questions, please contact:

<p>The GSI Group PO Box 20 1004 E. Illinois Street Assumption, IL 62510 Ph: 1-217-226-4421</p>
--

3. SAFETY DECALS

Check components shown below to insure that the safety decals are in place and in good condition. If a decal cannot be easily read for any reason or has been painted over, replace it immediately. Contact your dealer or the manufacturer to order a replacement Decal free of charge.

Contact:

The GSI Group
 1004 E. Illinois Street
 Assumption, IL 62510
 Ph: 1-217-226-4421

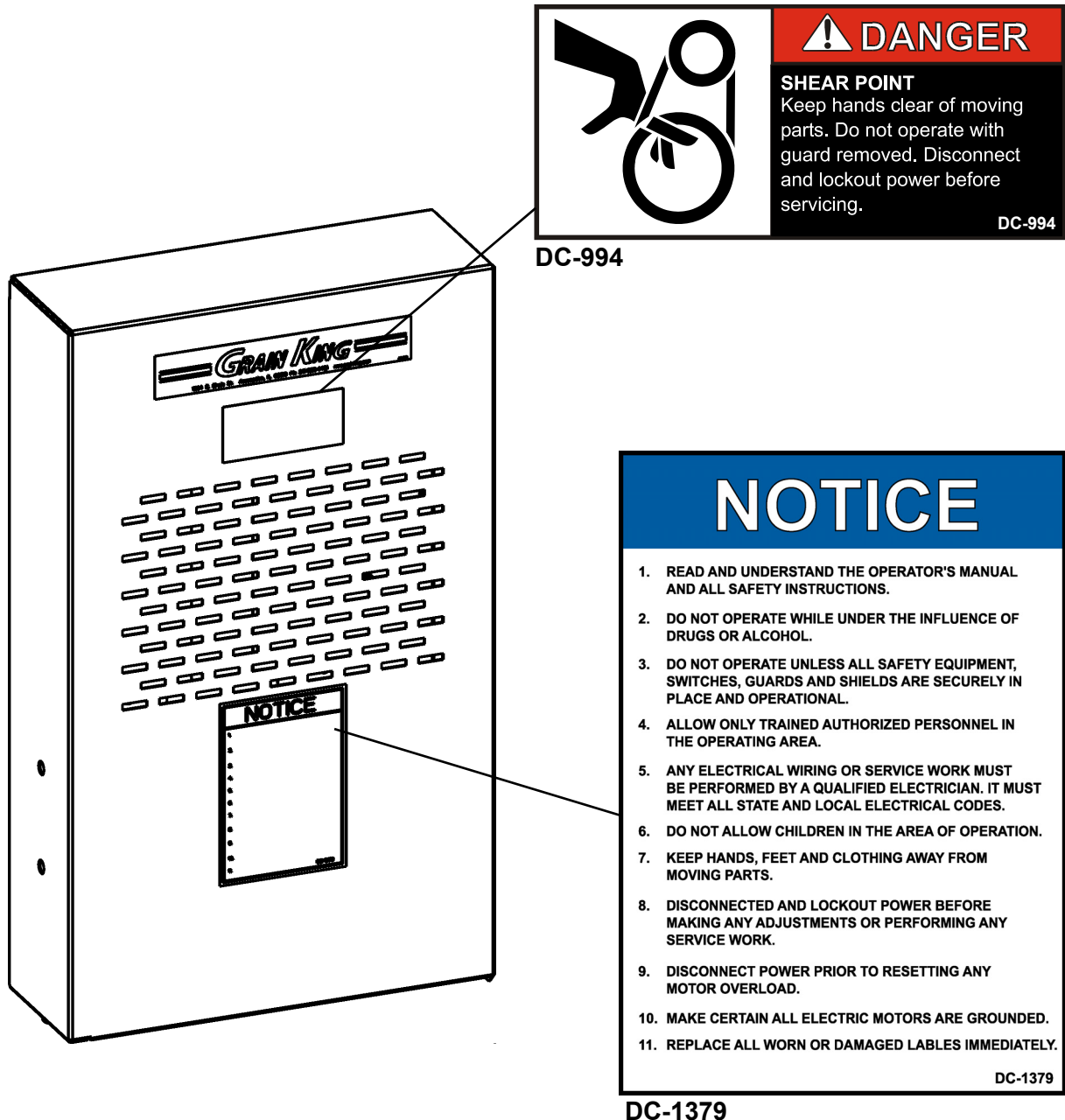



! DANGER

SHEAR POINT
 Keep hands clear of moving parts. Do not operate with guard removed. Disconnect and lockout power before servicing.

DC-994

DC-994

NOTICE

1. READ AND UNDERSTAND THE OPERATOR'S MANUAL AND ALL SAFETY INSTRUCTIONS.
2. DO NOT OPERATE WHILE UNDER THE INFLUENCE OF DRUGS OR ALCOHOL.
3. DO NOT OPERATE UNLESS ALL SAFETY EQUIPMENT, SWITCHES, GUARDS AND SHIELDS ARE SECURELY IN PLACE AND OPERATIONAL.
4. ALLOW ONLY TRAINED AUTHORIZED PERSONNEL IN THE OPERATING AREA.
5. ANY ELECTRICAL WIRING OR SERVICE WORK MUST BE PERFORMED BY A QUALIFIED ELECTRICIAN. IT MUST MEET ALL STATE AND LOCAL ELECTRICAL CODES.
6. DO NOT ALLOW CHILDREN IN THE AREA OF OPERATION.
7. KEEP HANDS, FEET AND CLOTHING AWAY FROM MOVING PARTS.
8. DISCONNECTED AND LOCKOUT POWER BEFORE MAKING ANY ADJUSTMENTS OR PERFORMING ANY SERVICE WORK.
9. DISCONNECT POWER PRIOR TO RESETTING ANY MOTOR OVERLOAD.
10. MAKE CERTAIN ALL ELECTRIC MOTORS ARE GROUNDED.
11. REPLACE ALL WORN OR DAMAGED LABELS IMMEDIATELY.

DC-1379

DC-1379

4. INSTALLATION

1. Prepare the Powerhead.
 - A. Disconnect and lockout all power to the Unload Auger.

⚠ DANGER ⚠

A main power disconnect switch capable of being locked only in the off position should be used. The Switch should be locked out whenever work is being done on the Powerhead.

- B. After the equipment has been disconnected and locked out, remove the existing Belt Guard Assembly.
 - a. Open the existing Belt Guard.
 - b. Adjust the Motor to relieve the tension on the Drive Belt(s).
 - c. Remove the Drive Belt(s).
 - d. Remove the Motor Pulley and Drive Sheave.
 - e. Unbolt and remove the existing Belt Guard Assembly.
- C. With the Belt Guard removed, inspect the Auger Bearing and grease or replace as necessary.
- D. Wherever possible, remove the Motor from the Powerhead to ease removal and installation of the Belt Guard Mounting Bracket(s).

Note: In a case where no previous Belt Guard is installed, the Drive Belt(s), Motor Pulley, and Drive Sheave can remain in place, except the Horizontal Drive on 8" Double Drive Vertical Powerheads.

E. Removal of existing Belt Guard Brackets.

- a. On 6", 8", and 10" Single Drive Verticals, unbolt the two (2) 3/8" x 1" Hex bolts, lock washers, and flat washers attaching the Belt Guard Bracket.

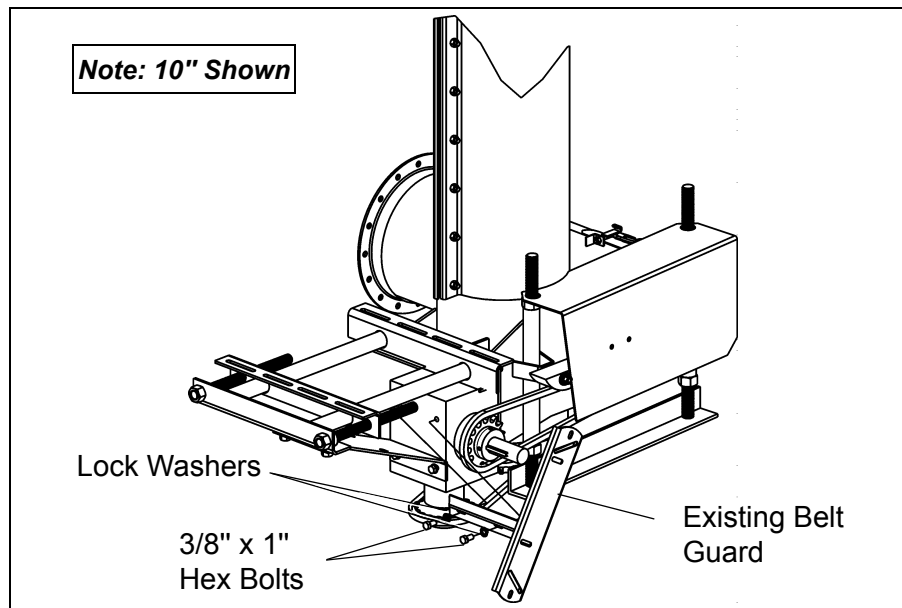

Figure 4A

- b. On 6", 8", 10" Horizontal and 25° Powerheads, loosen the 3/4" Motor Mount Adjustment Nuts.

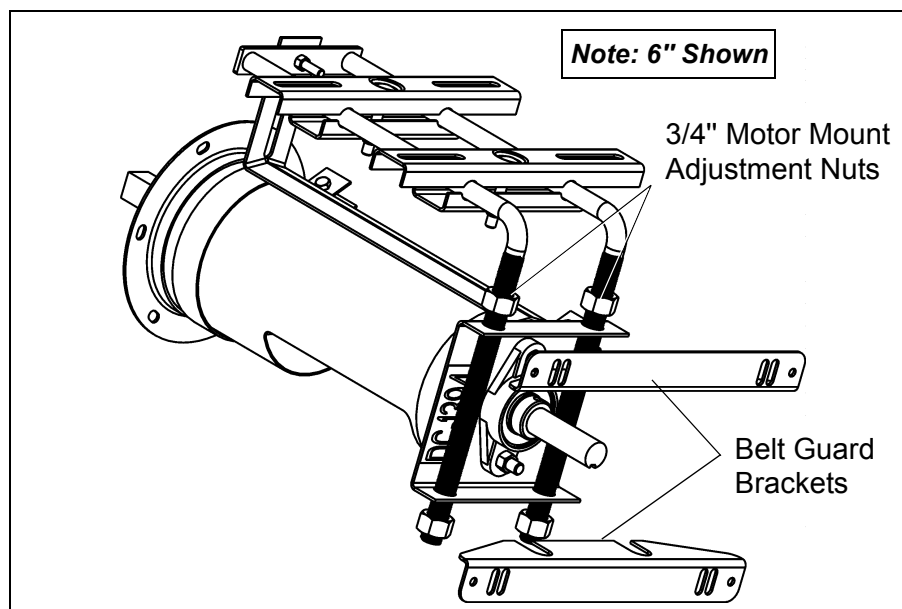

Figure 4B

Installation

- c. The Horizontal Drive on 8" Double-Drive Vertical Augers requires disassembling the Motor Mount components to remove/replace the Belt Guard Brackets.
 - i. After the motor has been removed, loosen the 3/4" Hex nut underneath the Motor Mount Sides, holding down the Motor Mount Assembly.

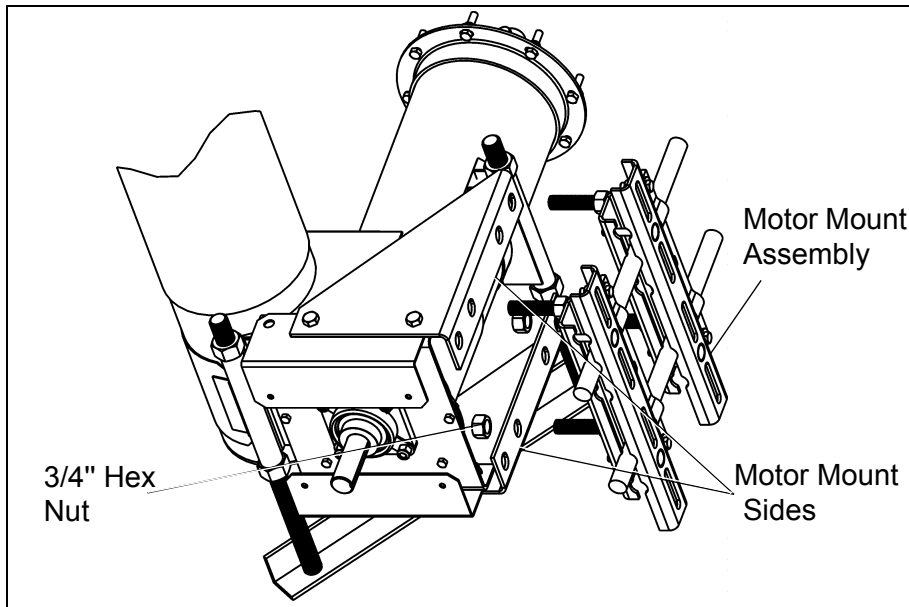

Figure 4C

- ii. Remove the Motor Mount Assembly.
 - iii. Unbolt the four (4) 1/2" x 1" Hex bolts, lock washers, and Hex nuts, and remove the existing Belt Guard Brackets.

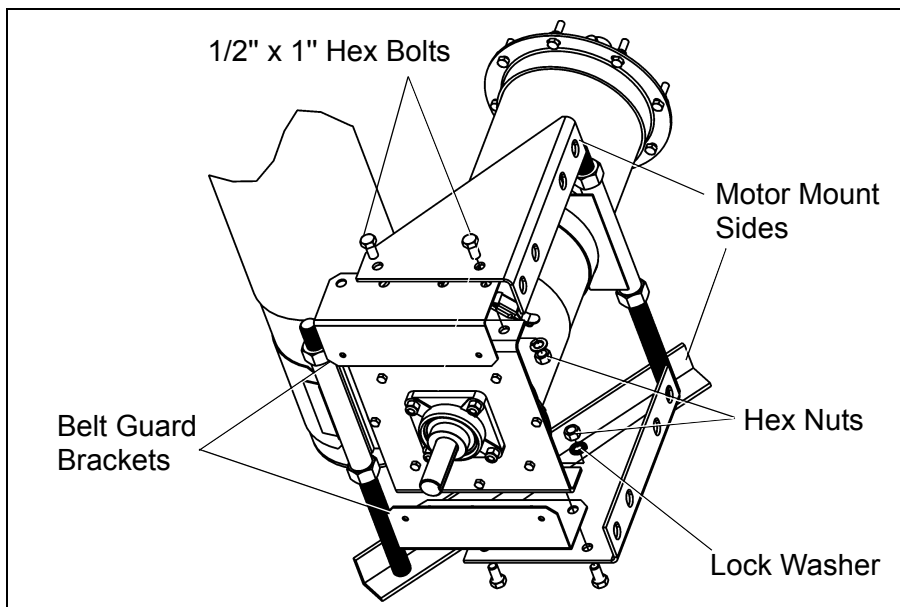

Figure 4D

2. Installation of New Belt Guard Brackets.

- A. 6", 8", 10" Horizontal and 25° Powerheads, also the Vertical Drive on 8" Double-Drive Vertical Powerheads.
 - a. Place the New Belt Guard Brackets on the Motor Mount Adjustment Rods, with the tops of the Brackets facing away from the Drive Shaft.

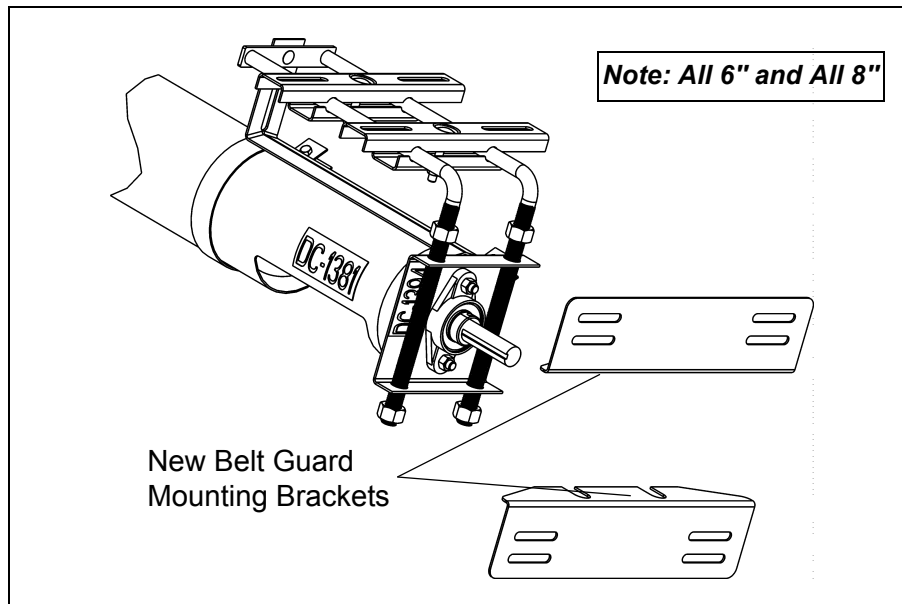

Figure 4E

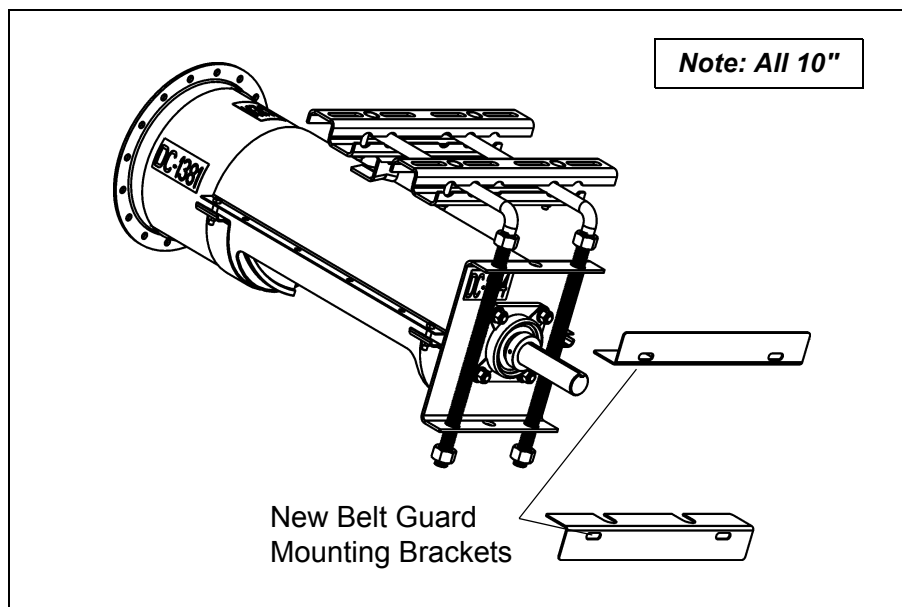

Figure 4F

- b. Slightly tighten the 3/4" Motor Mount Adjustment Nuts to hold the Brackets. You will need to adjust these to put the Motor in the proper position later.

Installation

B. 6", 8", 10" Single-Drive Vertical Powerheads.

- a. Bolt the New Belt Guard Mounting Bracket to the 90° gearbox with the two (2) supplied 3/8" x 3/4" Flange bolts. Leave them slightly loose to adjust the Belt Guard position later.

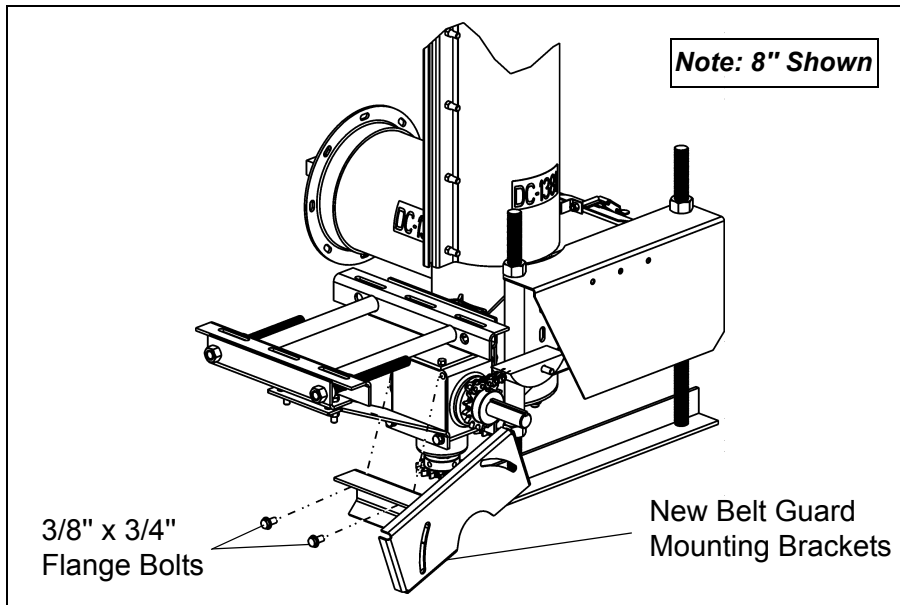

Figure 4G

C. Horizontal Drive on 8" Double-Drive Vertical Augers.

- a. Bolt the New Belt Guard Brackets and the Motor Mount Sides to the Powerhead, with the Brackets pointing towards each other, and slots facing away from the Auger, using the four (4) 1/2" x 1" Hex bolts, lock washers, and Hex nuts removed previously.

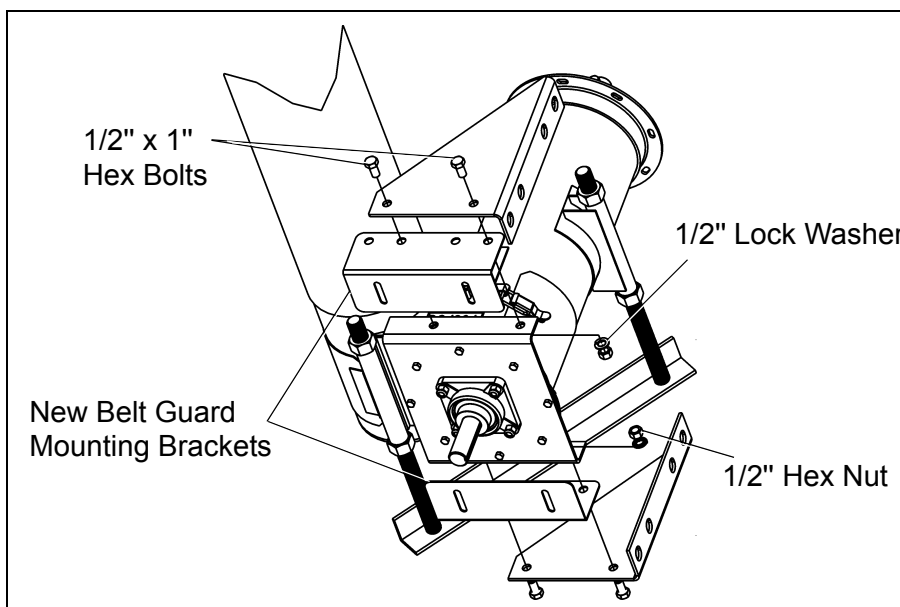

Figure 4H

- b. Reinstall the motor mount assembly, and loosely tighten the 3/4" Motor Mount Adjustment Nuts.

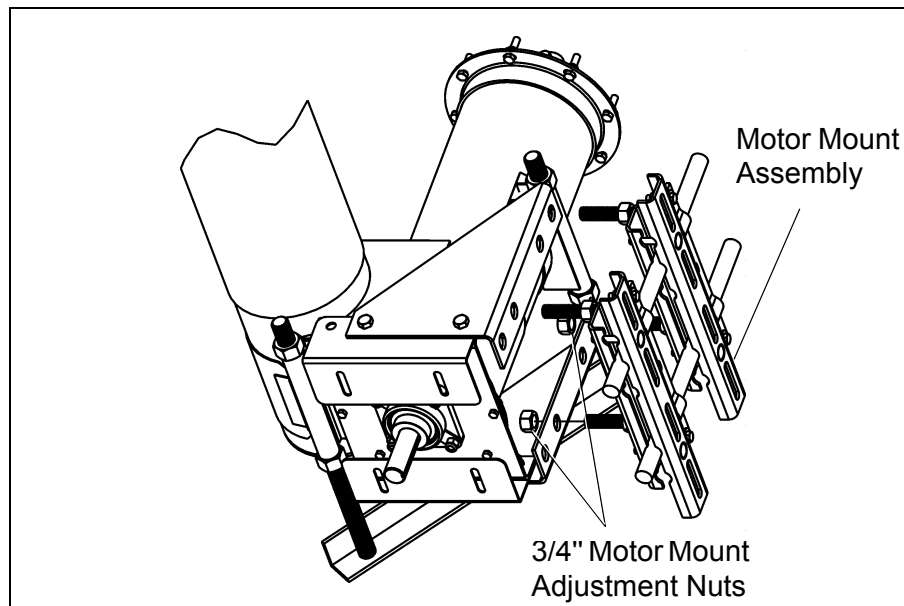

Figure 41

- c. Reinstall the Motor and Motor Pulley to the Motor Mount Straps. Adjust the Motor placement along the tube and tighten the Motor Mount Assembly and Motor attachment bolts.
3. Reinstall Auger Drive Sheave and the Drive belts. Adjust the Motor placement to produce adequate tension on the belts.
4. Tighten all Motor Mount Component nuts and bolts.

Installation

5. Install the New Belt Guard.
 - A. Remove the 3/8" x 3/4" Flange bolt from the Bottom Belt Guard Cover, holding it in place.
 - B. Remove the Cover.
 - C. Slip the Belt Guard down over the Motor and Drive Sheaves, enclosing the Drive belts.
 - D. Bolt the Belt Guard loosely to the Belt Guard Mounting Bracket(s) with the supplied two (2) or four (4) 3/8" x 3/4" Flange bolts. Consult the Figures below for your application.

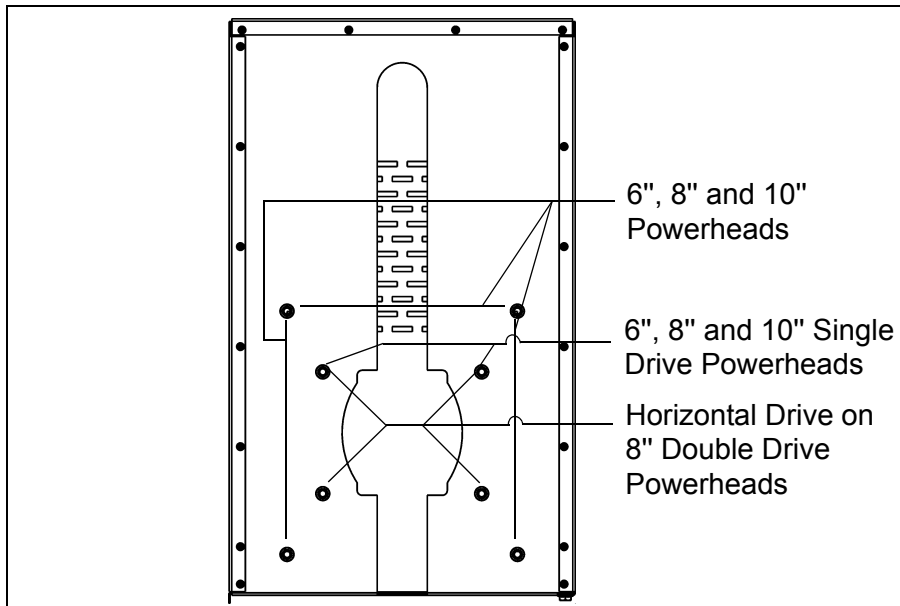

Figure 4J

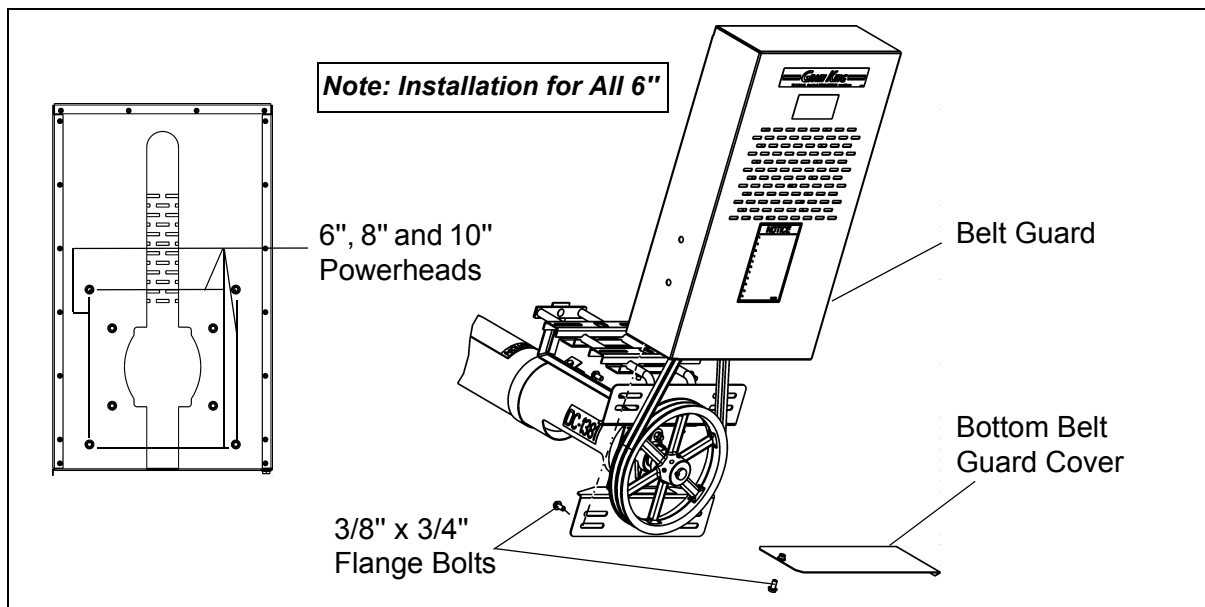

Figure 4K

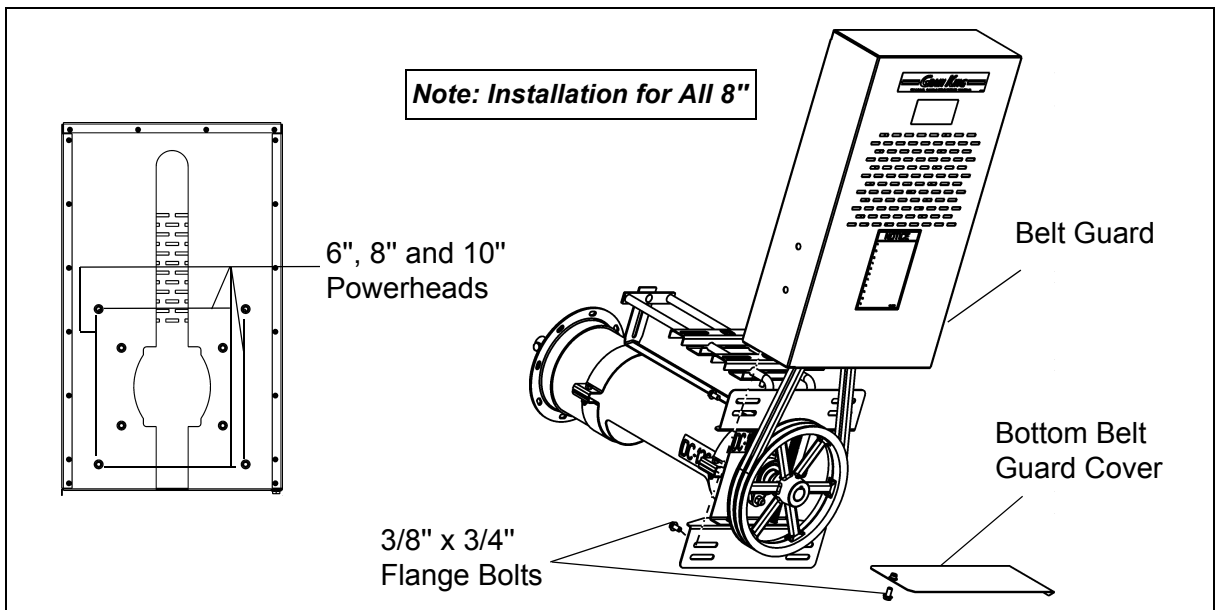

Figure 4L

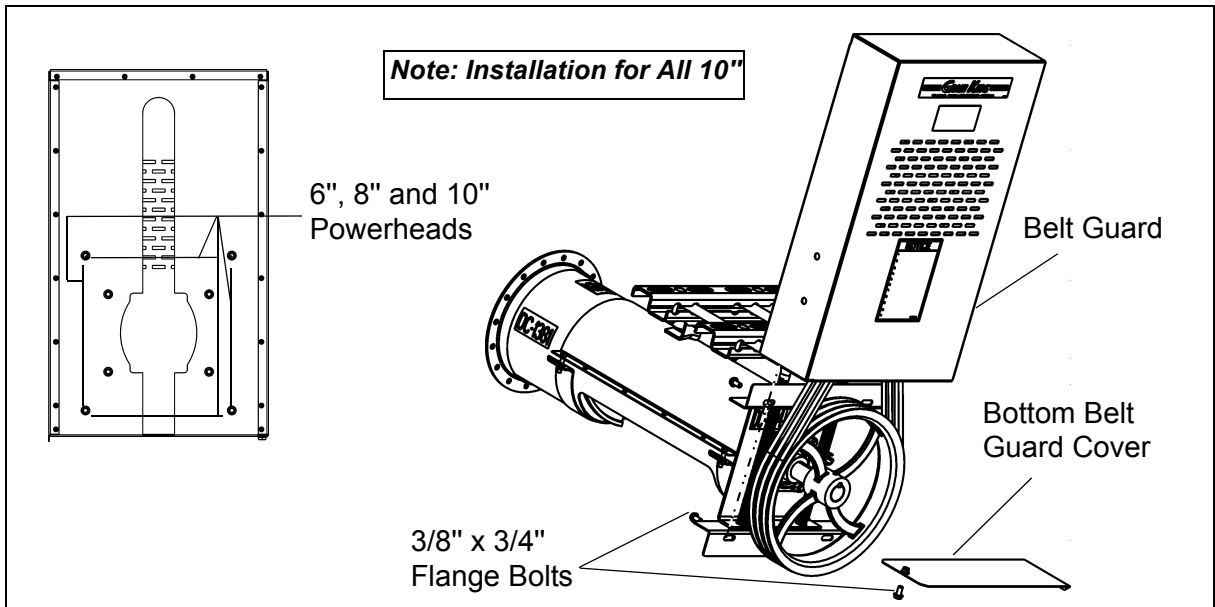

Figure 4M

Installation

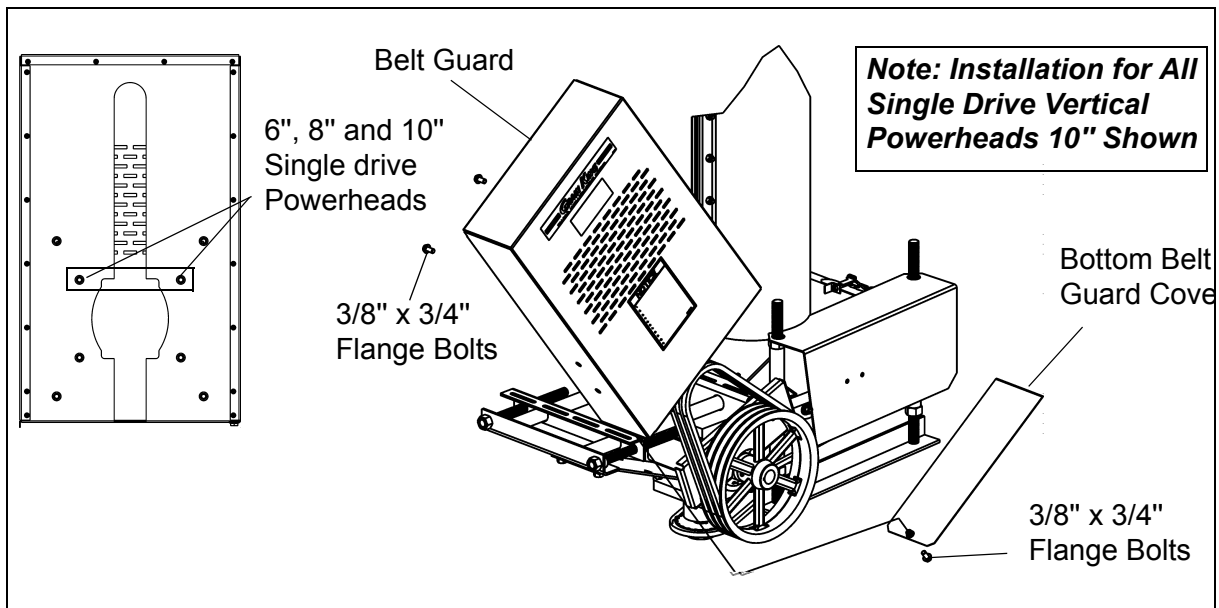

Figure 4N

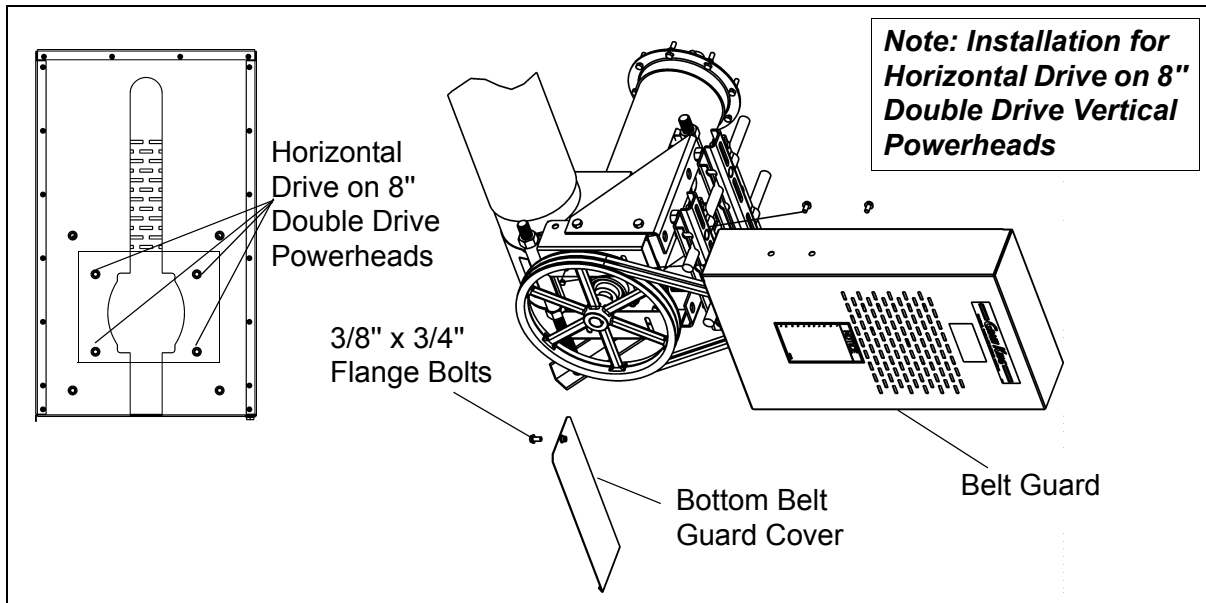
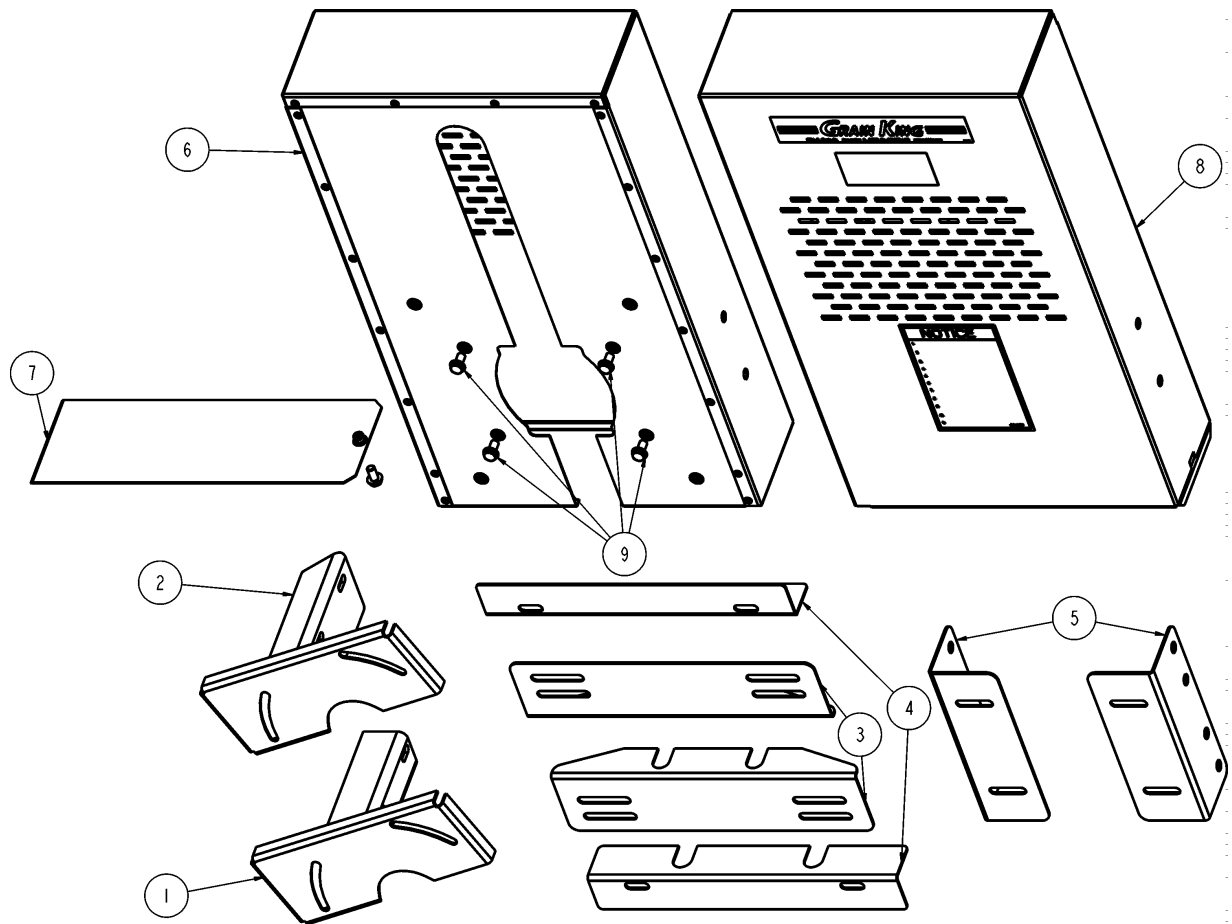

Figure 4O

- E. Center the Belt Guard slot with the Motor Shaft and the Auger Drive Shaft. Make sure the Belt Guard DOES NOT contact the pulleys, belts, or bearing, and tighten the Belt Guard to the Belt Guard Mounting Bracket(s).
- F. Once the Belt Guard is secured, slide the Bottom Belt Guard Cover back into place and secure it with the 3/8" x 3/4" Flange bolt previously removed.

5. PARTS LIST

1. Replacement Belt Guard Components



Ref #	Part #	Description
1	GK7317	6" & 8" Single Drive Vertical Mounting Bracket
2	GK7322	10" Single Drive Vertical Mounting Bracket
3	GC11544	6" & 8" Mounting Bracket
4	GC11543	10" Mounting Bracket
5	GC11545	8" Double Drive Vertical Horizontal Mounting Bracket
6	GK7314	Belt Guard Top Assembly
7	GK7004	Belt Guard Bottom Assembly
8	GK7532	Replacement Belt Guard Assembly
9	S-9067	3/8"-16 x 3/4" Flange Bolt Zinc Grade 5

6. WARRANTY

THE GSI GROUP, INC. (GSI) WARRANTS ALL PRODUCTS WHICH IT MANUFACTURES TO BE FREE OF DEFECTS IN MATERIAL AND WORKMANSHIP UNDER NORMAL USAGE AND CONDITIONS FOR A PERIOD OF 12 MONTHS AFTER RETAIL SALE TO THE ORIGINAL END USER. THE PURCHASER'S SOLE REMEDY AND GSI'S ONLY OBLIGATION SHALL BE TO REPAIR OR REPLACE, AT GSI'S OPTION AND EXPENSE, PRODUCTS THAT, IN GSI'S SOLE JUDGMENT, CONTAIN A MATERIAL DEFECT DUE TO MATERIALS OR WORKMANSHIP. ALL DELIVERY AND SHIPMENT CHARGES TO AND FROM GSI'S FACTORY WILL BE PURCHASER'S RESPONSIBILITY. EXPENSES INCURRED BY OR ON BEHALF OF THE PURCHASER WITHOUT PRIOR WRITTEN AUTHORIZATION FROM AN AUTHORIZED EMPLOYEE OF GSI SHALL BE THE SOLE RESPONSIBILITY OF THE PURCHASER.

EXCEPT FOR THE LIMITED WARRANTY EXPRESSED ABOVE, GSI MAKES NO FURTHER WARRANTY OF ANY KIND, EXPRESS OR IMPLIED, INCLUDING, WITHOUT LIMITATION, WARRANTIES OF MERCHANTABILITY OR FITNESS FOR A PARTICULAR PURPOSE OR USE IN CONNECTION WITH (I) PRODUCT MANUFACTURED OR SOLD BY GSI OR (II) ANY ADVICE, INSTRUCTION, RECOMMENDATION OR SUGGESTION PROVIDED BY AN AGENT, REPRESENTATIVE OR EMPLOYEE OF GSI REGARDING OR RELATED TO THE CONFIGURATION, INSTALLATION, LAYOUT, SUITABILITY FOR A PARTICULAR PURPOSE, OR DESIGN OF SUCH PRODUCTS.

GSI SHALL NOT BE LIABLE FOR ANY DIRECT, INDIRECT, INCIDENTAL OR CONSEQUENTIAL DAMAGES, INCLUDING, WITHOUT LIMITATION, LOSS OF ANTICIPATED PROFITS OR BENEFITS. PURCHASER'S SOLE AND EXCLUSIVE REMEDY IS AS SET FORTH IN THE LIMITED WARRANTY EXPRESSED ABOVE, WHICH SHALL NOT EXCEED THE AMOUNT PAID FOR THE PRODUCT PURCHASED. THIS WARRANTY IS NOT TRANSFERABLE AND APPLIES ONLY TO THE ORIGINAL PURCHASER. GSI SHALL HAVE NO OBLIGATION OR RESPONSIBILITY FOR ANY REPRESENTATIONS OR WARRANTIES MADE BY OR ON BEHALF OF ANY DEALER, AGENT OR DISTRIBUTOR OF GSI.

GSI ASSUMES NO RESPONSIBILITY FOR CLAIMS RESULTING FROM ERECTION DEFECTS OR UNAUTHORIZED MODIFICATIONS TO PRODUCTS WHICH IT MANUFACTURED. MODIFICATIONS TO PRODUCTS NOT SPECIFICALLY DELINEATED IN THE MANUAL ACCOMPANYING THE EQUIPMENT AT INITIAL SALE WILL NULLIFY THE PRODUCT WARRANTY THAT MIGHT HAVE BEEN OTHERWISE AVAILABLE.

THE FOREGOING WARRANTY SHALL NOT EXTEND TO PRODUCTS OR PARTS WHICH HAVE BEEN DAMAGED BY NEGLIGENT USE, MISUSE, ALTERATION OR ACCIDENT. THIS WARRANTY EXTENDS SOLELY TO ONLY PRODUCTS MANUFACTURED BY GSI. THIS WARRANTY IS EXCLUSIVE AND IN LIEU OF ALL OTHER WARRANTIES EXPRESS OR IMPLIED. GSI RESERVES THE RIGHT TO MAKE DESIGN OR SPECIFICATION CHANGES AT ANY TIME.

PRIOR TO INSTALLATION, PURCHASER HAS THE RESPONSIBILITY TO COMPLY WITH ALL FEDERAL, STATE AND LOCAL CODES WHICH MAY APPLY TO THE LOCATION AND INSTALLATION OF PRODUCTS MANUFACTURED OR SOLD BY GSI.

This equipment shall be installed in accordance with the current installation codes and applicable regulations which should be carefully followed in all cases. Authorities having jurisdiction should be consulted before installations are made.

G S I G R O U P



**GSI Group, Inc.
1004 E. Illinois St.
Assumption, IL 62510-0020
Phone: 1-217-226-4421
Fax: 1-217-226-4420
Internet: <http://www.grainsystems.com>**