

# 8", 10" and 12" Commercial Vertical Drive Unit - Dual Drive (Bottom, Bottom Drive)

Installation Manual

PNEG-1556

Date: 07-28-14

GSI GROUP



PNEG-1556



## Contents

<b>Chapter 1 Safety</b> .....	<b>4</b>
Safety Guidelines .....	4
Safety Instructions .....	5
<b>Chapter 2 Decals</b> .....	<b>7</b>
Decals Section .....	7
<b>Chapter 3 Installation</b> .....	<b>9</b>
Preparing the Vertical Drive .....	9
Attaching the Auger to the Bin .....	12
Attaching the Horizontal Flight .....	12
Installing the Motor Mount Adjuster .....	14
Installing the Motor Mount Plate .....	17
Installing the Belt Guard Brackets .....	21
Installing the Pulley .....	23
Installing the Motor (Not Provided) .....	25
Installing the Belts .....	26
Installing the Belt Guard .....	27
Installing the Vertical Motor Cover .....	29
Electric Motor Drive Selection .....	30
Perform Pre-Start Checks .....	34
Start the Auger .....	35
Operate the Auger .....	36
Normal Shut Down .....	36
Emergency Shut Down .....	36
Lock Out .....	37
Storage Preparation .....	37
Maintenance.....	37
<b>Chapter 4 Parts List</b> .....	<b>39</b>
8" Top of Vertical Bin Unloader Parts .....	40
10" Top of Vertical Bin Unloader Parts .....	42
12" Top of Vertical Bin Unloader Parts .....	44
8" Horizontal Drive Parts .....	46
10" Horizontal Drive Parts .....	48
12" Horizontal Drive Parts .....	50
8" Vertical Drive Parts .....	52
10" Vertical Drive Parts .....	54
12" Vertical Drive Parts .....	56
<b>Chapter 5 Warranty</b> .....	<b>59</b>

### Safety Guidelines

This manual contains information that is important for you, the owner/operator, to know and understand. This information relates to protecting **personal safety** and **preventing equipment problems**. It is the responsibility of the owner/operator to inform anyone operating or working in the area of this equipment of these safety guidelines. To help you recognize this information, we use the symbols that are defined below. Please read the manual and pay attention to these sections. Failure to read this manual and its safety instructions is a misuse of the equipment and may lead to serious injury or death.



**This is the safety alert symbol. It is used to alert you to potential personal injury hazards. Obey all safety messages that follow this symbol to avoid possible injury or death.**



This symbol indicates an imminently hazardous situation which, if not avoided, **will result in serious injury or death.**



This symbol indicates a potentially hazardous situation which, if not avoided, **may result in serious injury or death.**



This symbol indicates a potentially hazardous situation which, if not avoided, **may result in minor or moderate injury.**



This symbol indicates a potentially hazardous situation which, if not avoided, **may result in property damage.**

## Safety Instructions

Our foremost concern is your safety and the safety of others associated with this equipment. We want to keep you as a customer. This manual is to help you understand safe operating procedures and some problems which may be encountered by the operator and other personnel.

As owner and/or operator, it is your responsibility to know what requirements, hazards, and precautions exist, and to inform all personnel associated with the equipment or in the area. Safety precautions may be required from the personnel. Avoid any alterations to the equipment. Such alterations may produce a very dangerous situation where SERIOUS INJURY or DEATH may occur.

This equipment shall be installed in accordance with the current installation codes and applicable regulations which should be carefully followed in all cases. Authorities having jurisdiction should be consulted before installations are made.

### Follow Safety Instructions

Carefully read all safety messages in this manual and safety signs on your machine. Keep signs in good condition. Replace missing or damaged safety signs. Be sure new equipment components and repair parts include the current safety signs. Replacement safety signs are available from the manufacturer.

Learn how to operate the machine and how to use controls properly. Do not let anyone operate without instruction.

Keep your machinery in proper working condition. Unauthorized modifications to the machine may impair the function and/or safety and affect machine life.

If you do not understand any part of this manual or need assistance, contact your dealer.

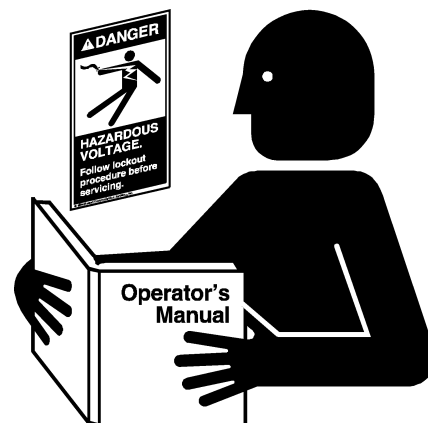

**Read and Understand Manual**

### Practice Safe Maintenance

Understand service procedures before doing work. Keep area clean and dry.

Never lubricate, service, or adjust machine while it is in operation. Keep hands, feet and clothing away from rotating parts.

Keep all parts in good condition and properly installed. Fix damage immediately. Replace worn or broken parts. Remove any built up grease, oil and debris.



**Maintain Equipment and Work Area**

# 1. Safety

## Prepare for Emergencies

Be prepared if fire starts.

Keep a first aid kit and fire extinguisher handy.

Keep emergency numbers for doctors, ambulance service, hospital, and fire department near your telephone.

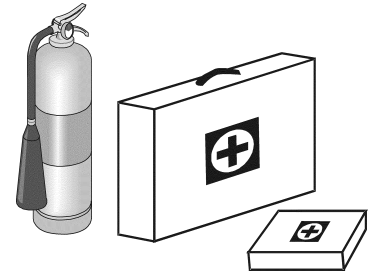

**Keep Emergency Equipment Quickly Accessible**

## Wear Protective Clothing

Wear close-fitting clothing and safety equipment appropriate to the job.

Remove all jewelry.

Tie long hair up and back.

Wear safety glasses at all times to protect eyes from debris.

Wear gloves to protect your hands from sharp edges on plastic or steel parts.

Wear steel-toed boots to help protect your feet from falling debris. Tuck in any loose or dangling shoestrings.

A respirator may be needed to prevent breathing potentially toxic fumes and dust.

Wear a hard hat to help protect your head.

Wear appropriate fall protection equipment when working at elevations greater than six feet (6').

**Eye Protection**

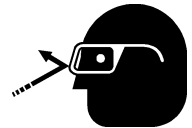

**Gloves**



**Steel-Toed Boots**



**Respirator**



**Hard Hat**



**Fall Protection**



## Decals Section

Check the components shown [on Page 8](#) to ensure that the safety decals are in place and in good condition. If a decal cannot be easily read for any reason or has been painted over, replace it immediately. Contact your dealer or the manufacturer to order the replacement decal **free** of charge.

### Decal Parts List

Part #	Description	Size
DC-834	DANGER - Unloading Auger	8-1/2" x 3-5/8"
DC-455	DANGER - Rotating Auger	4" x 5-3/4"
DC-994	DANGER - Shear Point	4-1/2" x 2"
DC-1379	DANGER - Notice	5-1/8" x 7-3/8"
DC-1234	NOTICE	2-1/4" x 2-3/4"
DC-1381	DANGER - Auger	2" x 4-1/2"
DC-1395	DANGER - Rotating Flight	4-1/4" x 6-1/4"
DC-1901	WARNING - No Step	2-1/2" x 5"

DANGER Decal No. DC-1395 was supplied with your bin unloading equipment. This safety sign should be applied to the side of the bin near the bin opening, so it will be viewed by people entering into the bin storage building. Do not cover any safety signs or any other signs that are already present.

**NOTE:** *Safety signs provide important safety information for people working near bin unloading equipment that is in operation.*



***If the safety sign cannot be easily read for any reason or has been painted over, replace it immediately. Additional safety signs may be obtained free of charge from your dealer, distributor or ordered from the factory.***

## 2. Decals



GSI Group 217-226-4421

Rotating flying parts can kill or dismember.



### DANGER

1. Keep all safety shields and devices in place.
2. Keep hands, feet, hair, loose clothing, and other objects away from moving parts.
3. Do not operate the machine unless visitors, children, and all other untrained personnel are well clear of the machine and work area.
4. Stop the machine and lock out power to clean, lubricate, service, or adjust.
5. Read operation and assembly manual completely before using equipment.

Failure to heed these warnings will result in serious injury or death.

DC-834

DC-834

### NOTICE

FAILURE TO PROPERLY SELECT, INSTALL OR MAINTAIN AN AUGER, ITS DRIVE OR OTHER COMPONENTS CAN RESULT IN DANGEROUS OPERATION.

THIS EQUIPMENT IF IMPROPERLY SELECTED, INSTALLED OR MAINTAINED MAY FAIL AND COULD RESULT IN SERIOUS INJURY OR PROPERTY DAMAGE.

CHECK PRODUCT LITERATURE AND EQUIPMENT MANUFACTURER'S LITERATURE OR CALL THE FACTORY FOR FURTHER INFORMATION.

GSI Group 217-226-4421

DC-1234

DC-1234



GSI Group 217-226-4421

DC-1901



### WARNING

**SLIPS AND FALLS** can cause severe injuries. Do **NOT** step or stand on this area.

DC-1901



GSI Group 217-226-4421

DC-1381

(On both inspection covers)



### DANGER

**SHEAR POINT**  
Keep clear of rotating auger and moving parts. Do not remove or modify guards. Disconnect and lock out power before servicing. Failure to do so will result in serious INJURY or DEATH.

DC-1381

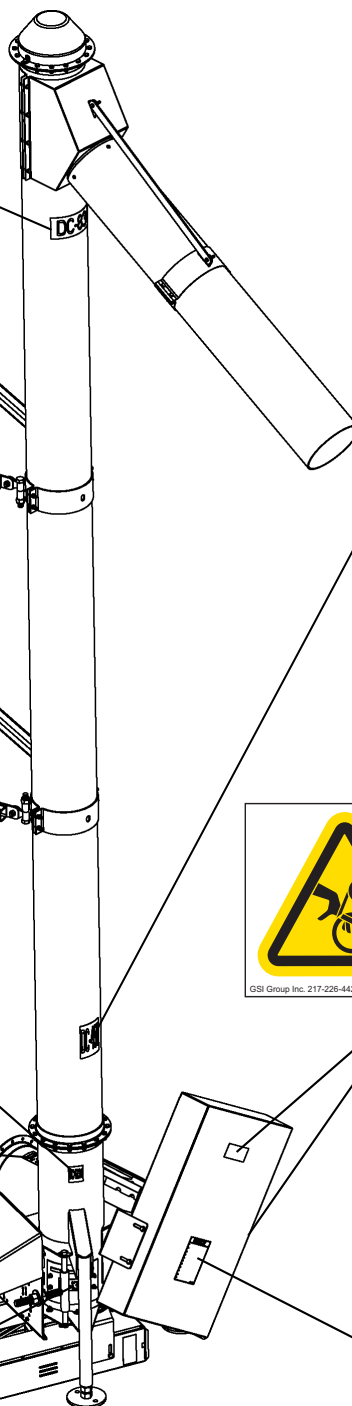

### DANGER



Keep clear of rotating auger and moving parts. Do not remove or modify guards. Disconnect and lockout power before servicing. Failure to do so will result in serious injury or death.

GSI Group 217-226-4421

DC-455

DC-455



GSI Group Inc. 217-226-4421



### DANGER

#### SHEAR POINT

Keep hands clear of moving parts. Do not operate with guard removed. Disconnect and lockout power before servicing.

DC-994

DC-994

(On both guards)

### NOTICE

1. Read and understand the operator's manual and all safety instructions.
2. Do not operate while under the influence of drugs or alcohol.
3. Do not operate unless all safety equipment, switches, guards, and shields are securely in place and operational.
4. Allow only trained authorized personnel in the operating area.
5. Any electrical wiring or service work must be performed by a qualified electrician. It must meet all state and local electrical codes.
6. Do not allow children in the area of operation.
7. Keep hands, feet, & clothing away from moving parts.
8. Disconnect and lockout power before making any adjustments or performing any service work.
9. Disconnect power prior to resetting any motor overload.
10. Make certain all electric motors are grounded.
11. Replace all worn or damaged labels immediately.

GSI Group Inc. 217-226-4421

DC-1379

DC-1379

(On both guards)



## Preparing the Vertical Drive

- A. Unbolt the *horizontal bearing plate (C)* from the *vertical auger assembly (A)*. (See [Figure 3A](#).) Set aside the *bearing plate (C)* with the *bearing (B)*, connecting hardware and the *horizontal flight (D)* until the auger is attached to the bin.

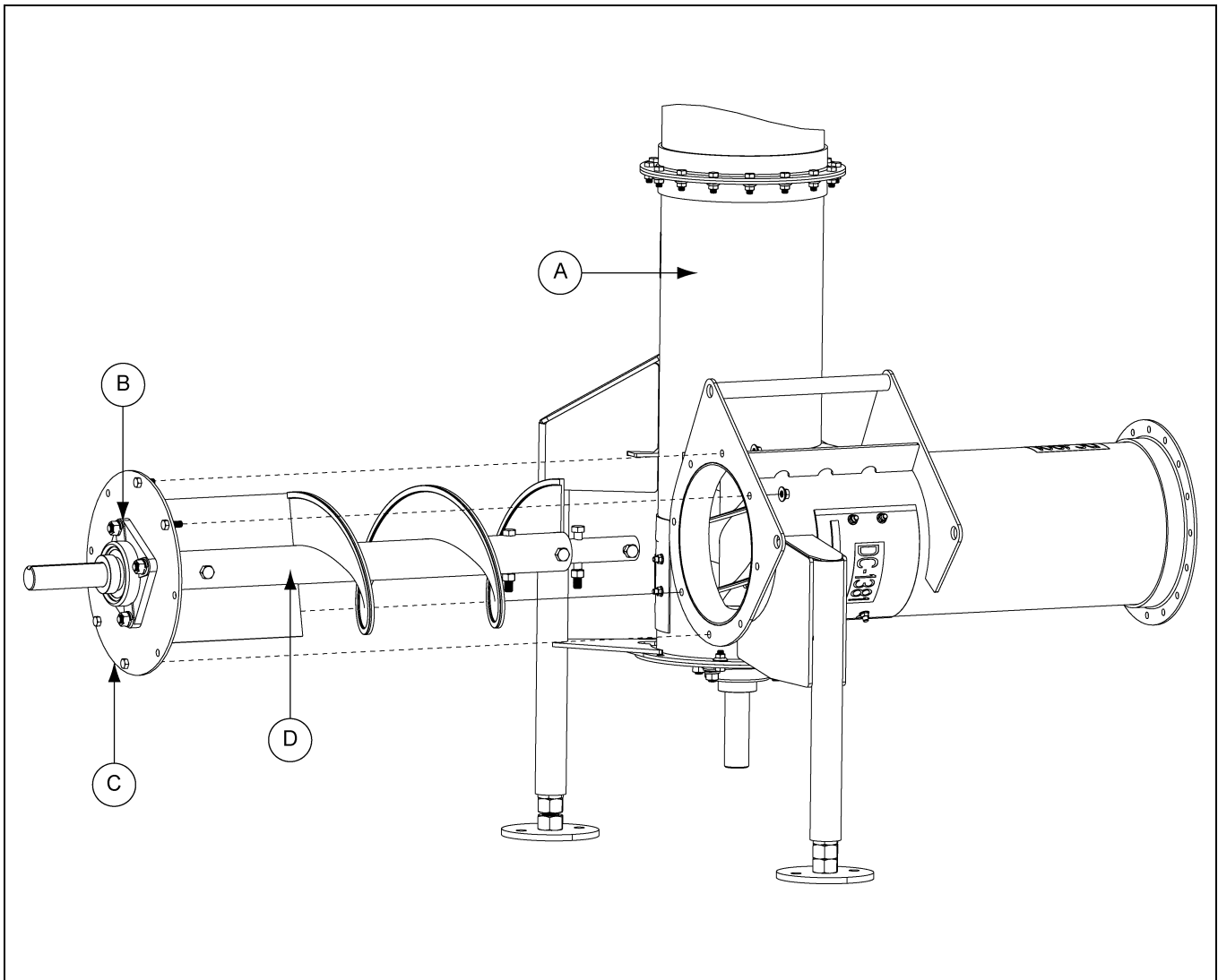

Figure 3A

Ref #	Description
A	Vertical Auger Assembly
B	Bearing
C	Horizontal Bearing Plate
D	Horizontal Flight

### 3. Installation

## Preparing the Vertical Drive (Continued)

- B. Attach the 60° spout (G) over the discharge opening (E) on the vertical tube. Secure the half band (F) and spout (G) with 5/16" x 1-1/2" hex bolts (I) and nylock nuts (H). (See Figure 3B.)
- C. Attach the half band (F) and the mounting bracket pivot band 56-1/2" below the bottom of the spout (G), 1/3<sup>rd</sup> of the tube length, using four (4) 3/8" x 1-1/2" hex bolts and 3/8" nylock nuts.

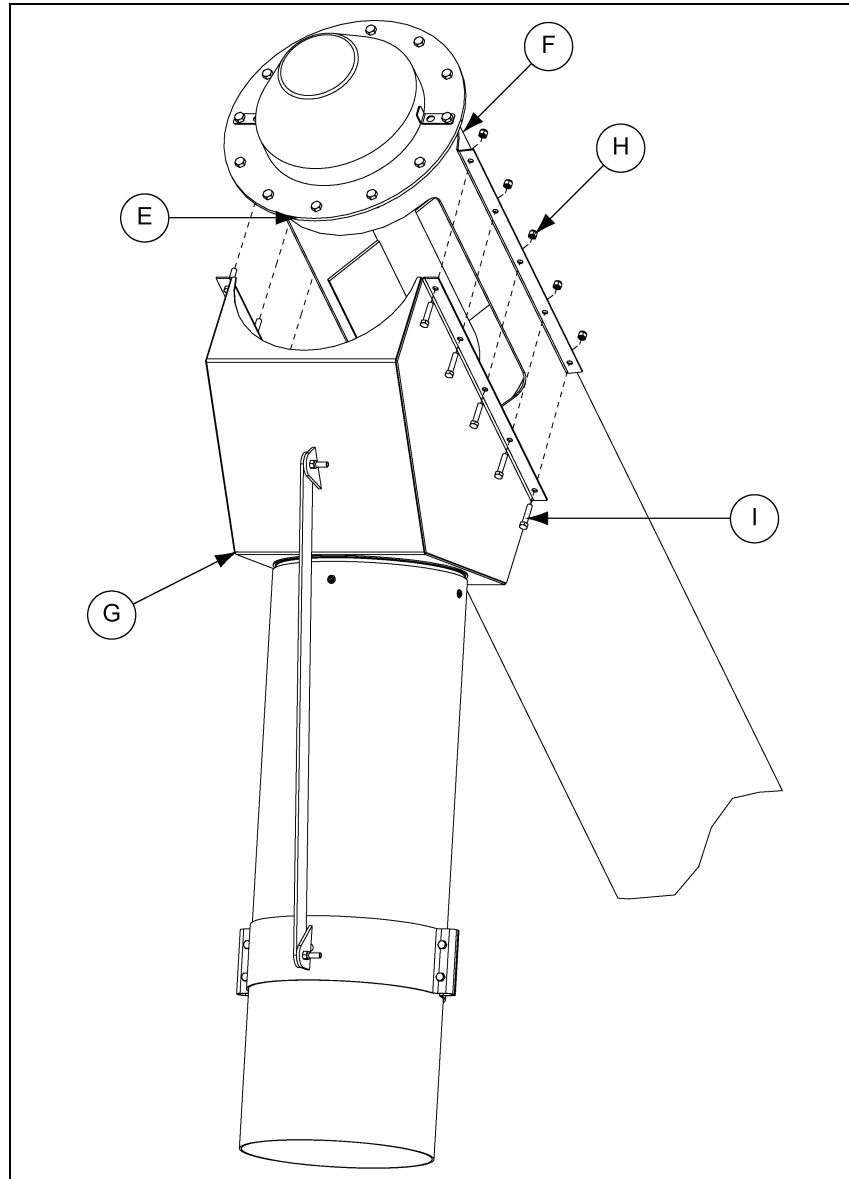

Figure 3B

Ref #	Description
E	Discharge Opening
F	Half Band
G	60° Spout
H	5/16" Nylock Nut
I	5/16" x 1-1/2" Hex Bolt

## Preparing the Vertical Drive (Continued)

- D. Attach the two (2) *leg support brackets* (Q) to the *mounting bracket pivot band* (J) using two (2) 3/4" x 4-1/2" hex bolts (O) and nylock nuts (P).
- E. Attach the two (2) *outer support legs* (L) to the *leg support brackets* (Q) using two (2) 1/2" x 1-1/4" hex bolts (R) and nylock nuts.
- F. Slide the two (2) *inner support legs* (K) into the *outer legs* (L) and temporarily secure with two (2) 3/8" x 2-1/2" hex bolts (T) and nylock nuts (S). (See [Figure 3C](#).)
- G. Repeat [Step C on Page 10](#) and [Step D-F](#) for the second set of legs, 56-1/2" below the first set of legs.

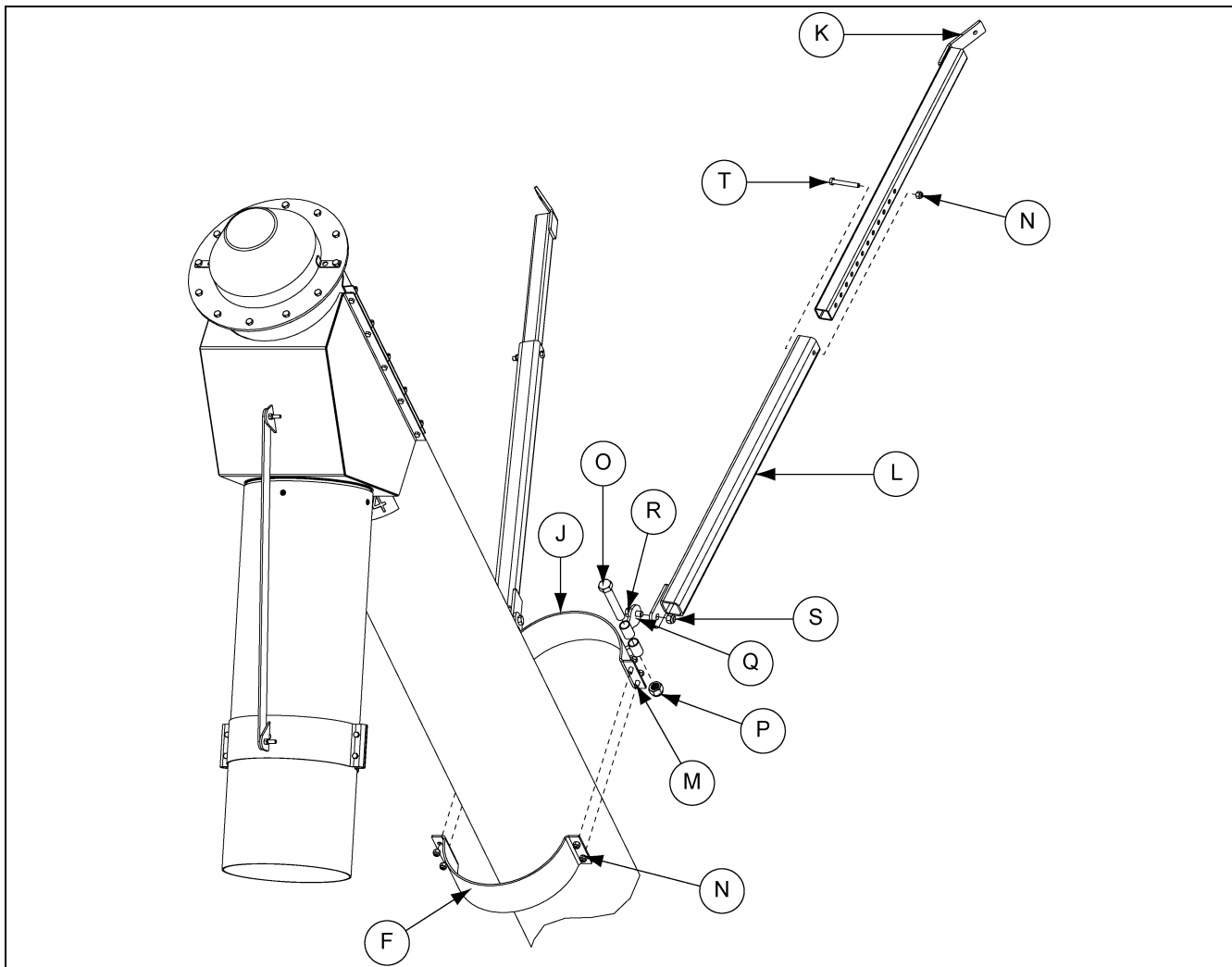

Figure 3C

Ref #	Description
F	Half Band
J	Mounting Bracket Pivot Band
K	Inner Support Leg
L	Outer Support Leg
M	3/8" x 1-1/2" Hex Bolt
N	3/8" Nylock Nut

Ref #	Description
O	3/4" x 4-1/2" Hex Bolt
P	3/4" Nylock Nut
Q	Leg Support Bracket
R	1/2" x 1-1/4" Hex Bolt
S	1/2" Nylock Nut
T	3/8" x 2-1/2" Hex Bolt

### 3. Installation

## Attaching the Auger to the Bin

- A. If the application requires an *adapter plate*, secure it to the bin unload tube before attaching the *vertical auger*. Make sure that the *adapter plate* has a bolt located at 12 O'clock, when facing the *unload tube*.
- B. Raise the *vertical auger* and bolt the *angle ring* on the *vertical auger* to the *angle ring* on the *unload tube*.
- C. Adjust the *feet* at the bottom of the *vertical auger* to support the weight. See the table for the appropriate minimum distance between the centerline of the unload tube and the ground.

Minimum Ground Clearance	
8"	17-1/4"
10"	19-7/8"
12"	18-3/8"

- D. Attach the *inner support legs* to the bin wall.
- E. Adjust and tighten all the hardware for the support legs.

## Attaching the Horizontal Flight

- A. Slide the *bin unload flight (B)* out through the *vertical auger*. In some applications the flight may have to be unbolted from the center well.
- B. Attach the *horizontal head flight* and *bearing plate assembly* with the appropriate hex bolts and stover nuts. (See [Figure 3D on Page 13.](#))

Flight Attachment Hardware Size	
8"	Two (2) 7/16" x 3" Grade 8 Hex Bolts and Stover Nuts
10"	Two (2) 1/2" x 3-1/2" Grade 8 Hex Bolts and Stover Nuts
12"	Two (2) 5/8" x 4" Grade 8 Hex Bolts and Stover Nuts

## Attaching the Horizontal Flight (Continued)

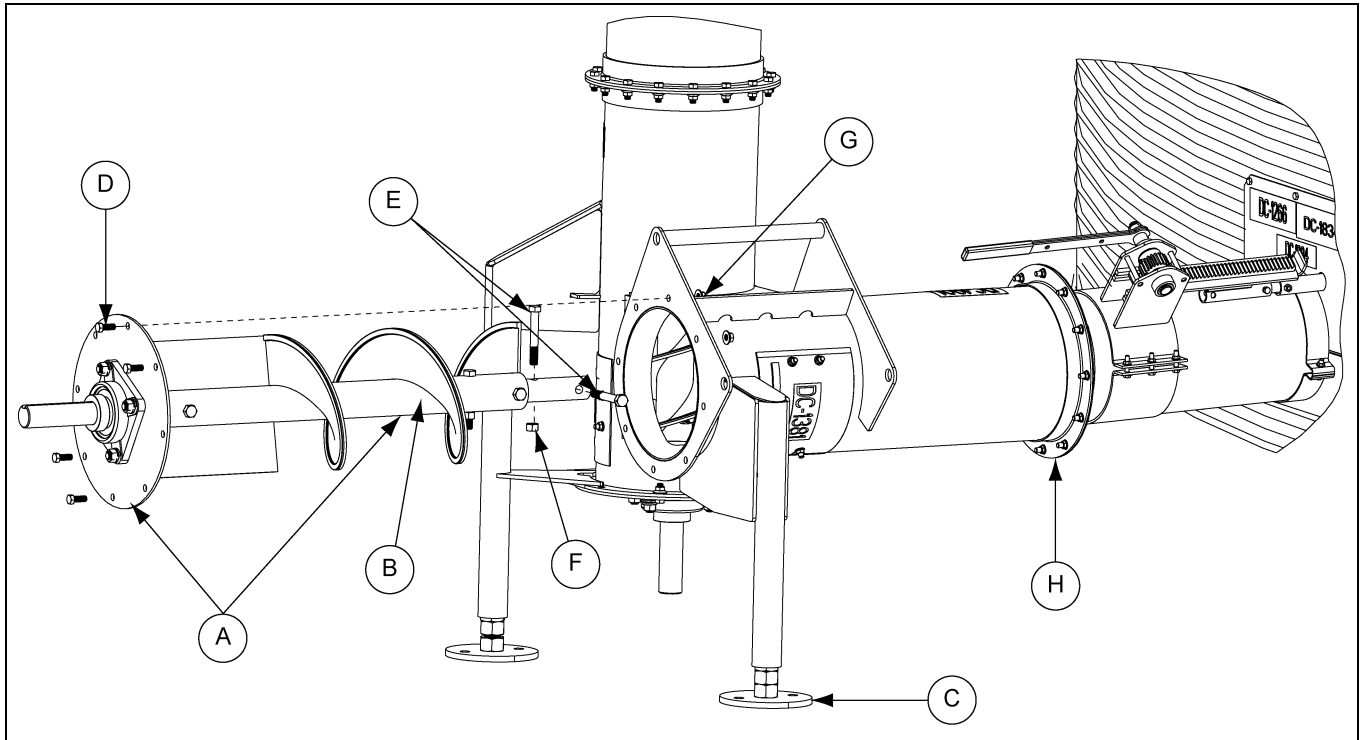

Figure 3D

Ref #	Description
A	Horizontal Flight and Bearing Plate Assembly
B	Bin Unload Flight
C	Vertical Auger Adjusting Foot
D	Hex Bolt
E	Flight Bolts
F	Stover Nut
G	Serrated Flange Nut
H	Angle Rings

- C. Slide the flights into the unload tube. If necessary, re-attach the unload flight to the center well.
- D. Rotate the *bearing plate* until the *head plate* and the *bearing plate* holes align.
- E. Re-attach the *horizontal bearing plate* to the *vertical auger* with ONLY the UPPER and LOWER holes, using the appropriate hex bolts and serrated flange nuts.

Bearing Plate Attachment Hardware Size	
8"	Four (4) 5/16" x 1" Grade 5 Hex Bolts and Serrated Flange Nuts
10" and 12"	Four (4) 3/8" x 1" Grade 5 Hex Bolts and Serrated Flange Nuts

### 3. Installation

## Installing the Motor Mount Adjuster

- A. Place the *motor mount adjuster* (C) between the back plate (B) and the head plate (A) on the cross-tube.
- B. Insert the *pivot rod* (E) through the back and head plates (B and A) and the *motor mount adjuster* (C). Secure the *pivot rod* (E) in place with two (2) 3/16" x 2" cotter pins (D). (See [Figure 3E](#) below and [Figure 3F on Page 15.](#))

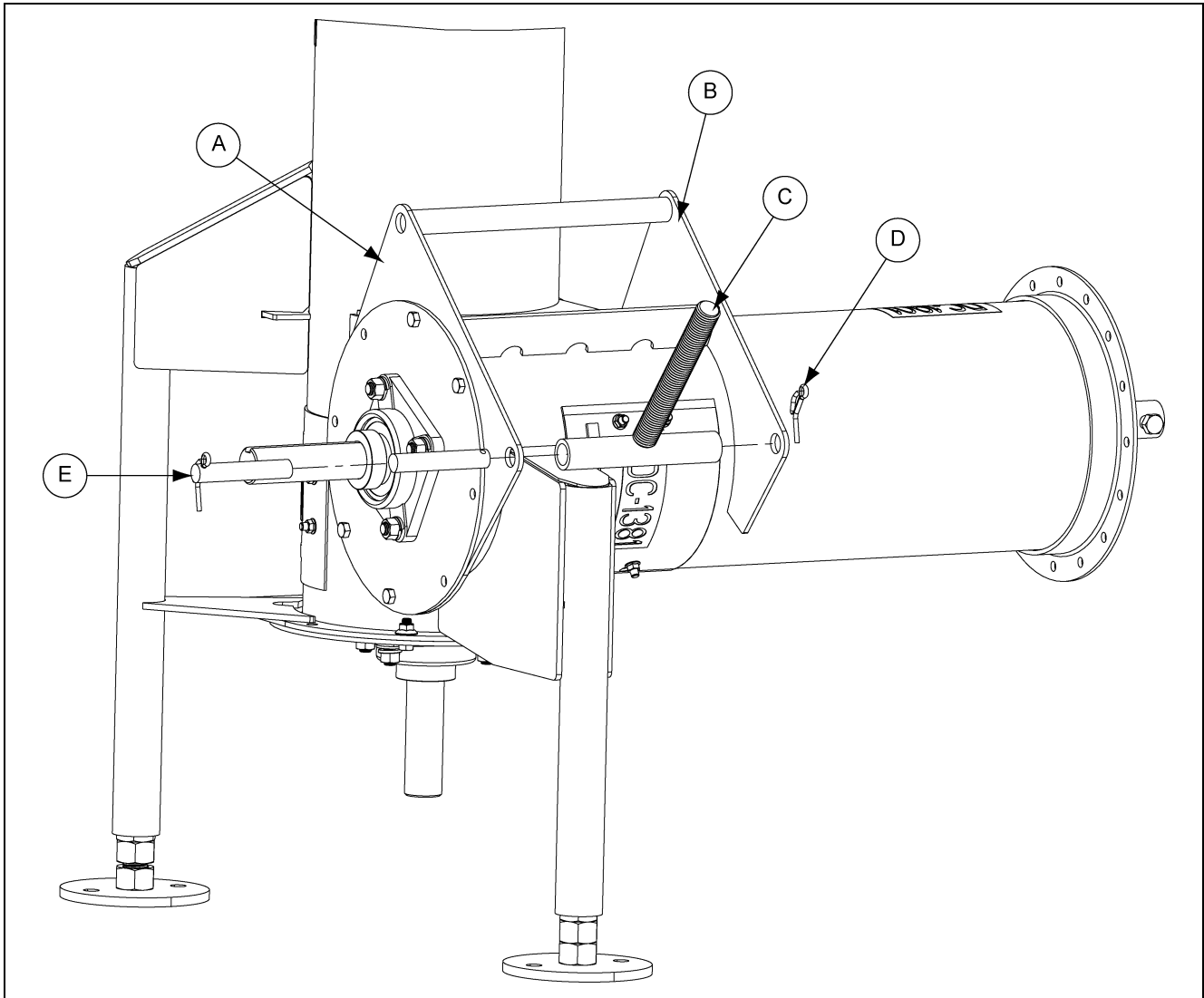

Figure 3E

Ref #	Description
A	Head Plate
B	Back Plate
C	Motor Mount Adjuster
D	3/16" x 2" Cotter Pin
E	Pivot Rod

## Installing the Motor Mount Adjuster (Continued)

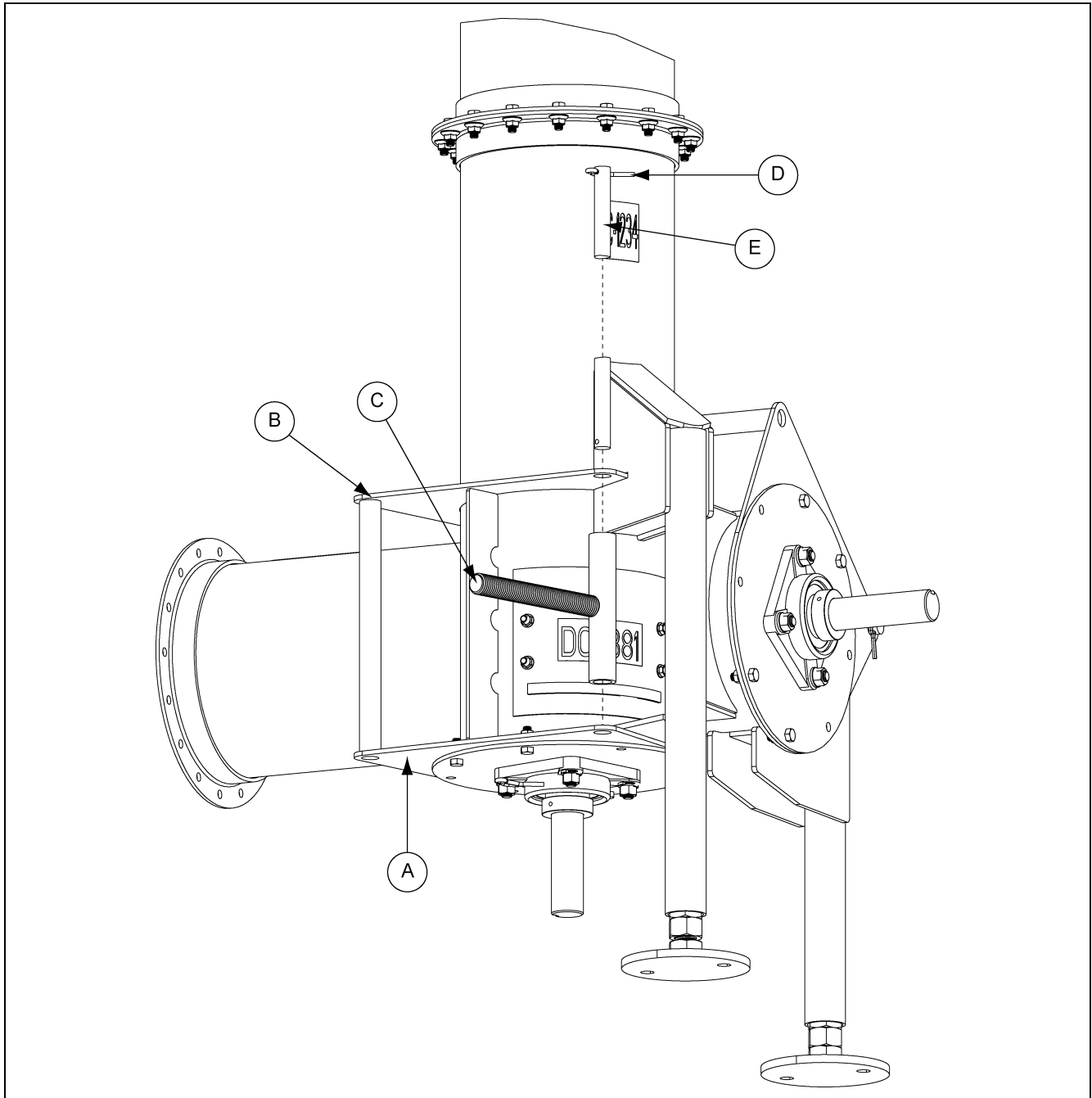

Figure 3F

Ref #	Description
A	Head Plate
B	Back Plate
C	Motor Mount Adjuster
D	3/16" x 2" Cotter Pin
E	Pivot Rod

### 3. Installation

## Installing the Motor Mount Adjuster (Continued)

C. With the cotter pins in the *pivot rod (E)*, bend one tab of the cotter pin back so that it touches the *pivot rod (E)* and bend the other tab of the cotter pin away from the first tab. (See *Figure 3G.*)

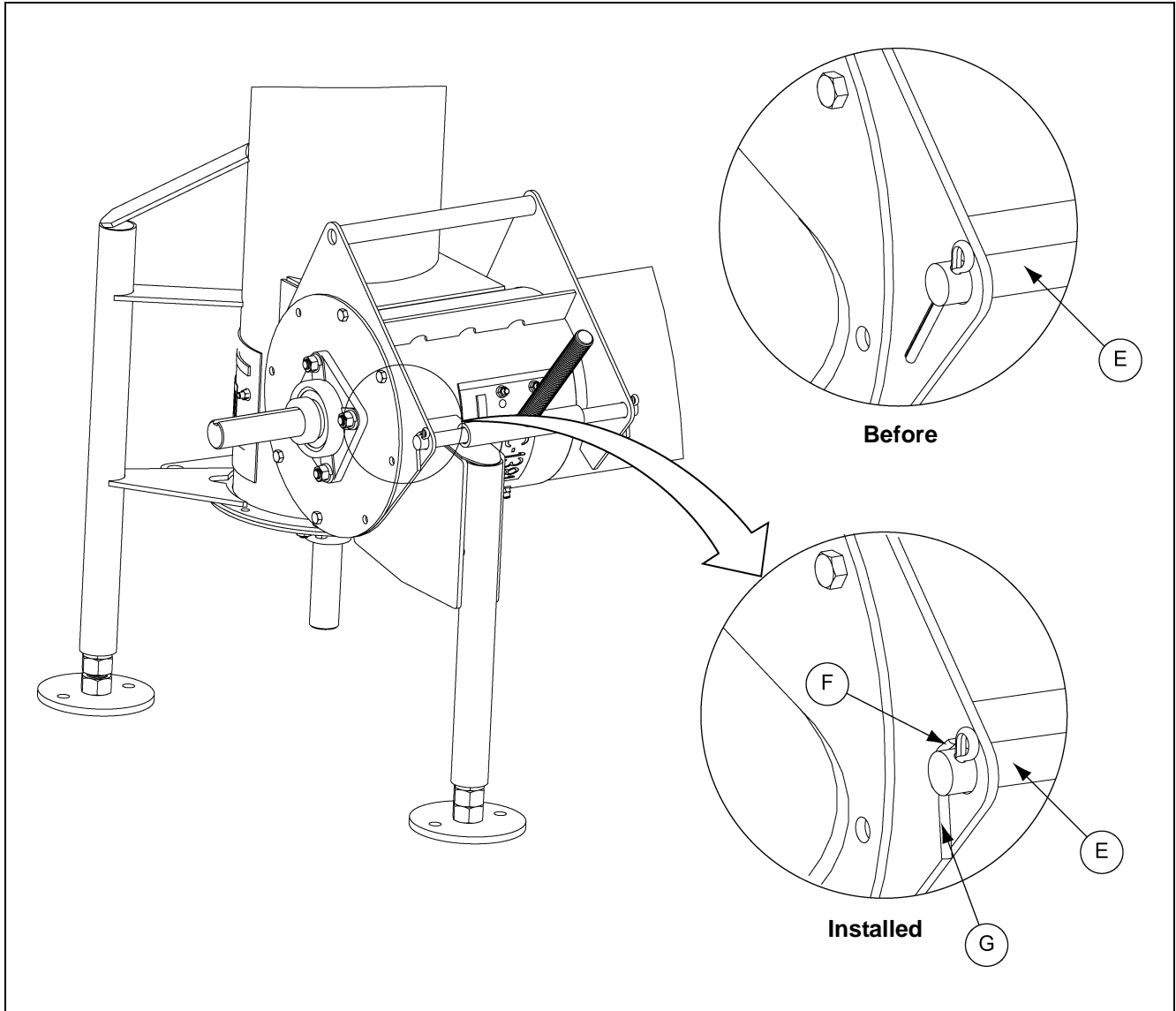

Figure 3G

Ref #	Description
E	Pivot Rod
F	Bend and Touching
G	Bend Away



## Installing the Motor Mount Plate

- A. Thread one of the *motor mount adjustment nuts* (F) and one of the *motor mount adjustment washers* (E) approximately three-quarters (3/4) of the way down the *motor mount adjuster's threaded rod* (D).
- B. Once the nut and washer are in place, slip the *motor mount plate* (A) over the adjuster and align the pivot holes with the pivot tube (G). (See [Figure 3H below](#) and [Figure 3I on Page 18.](#))

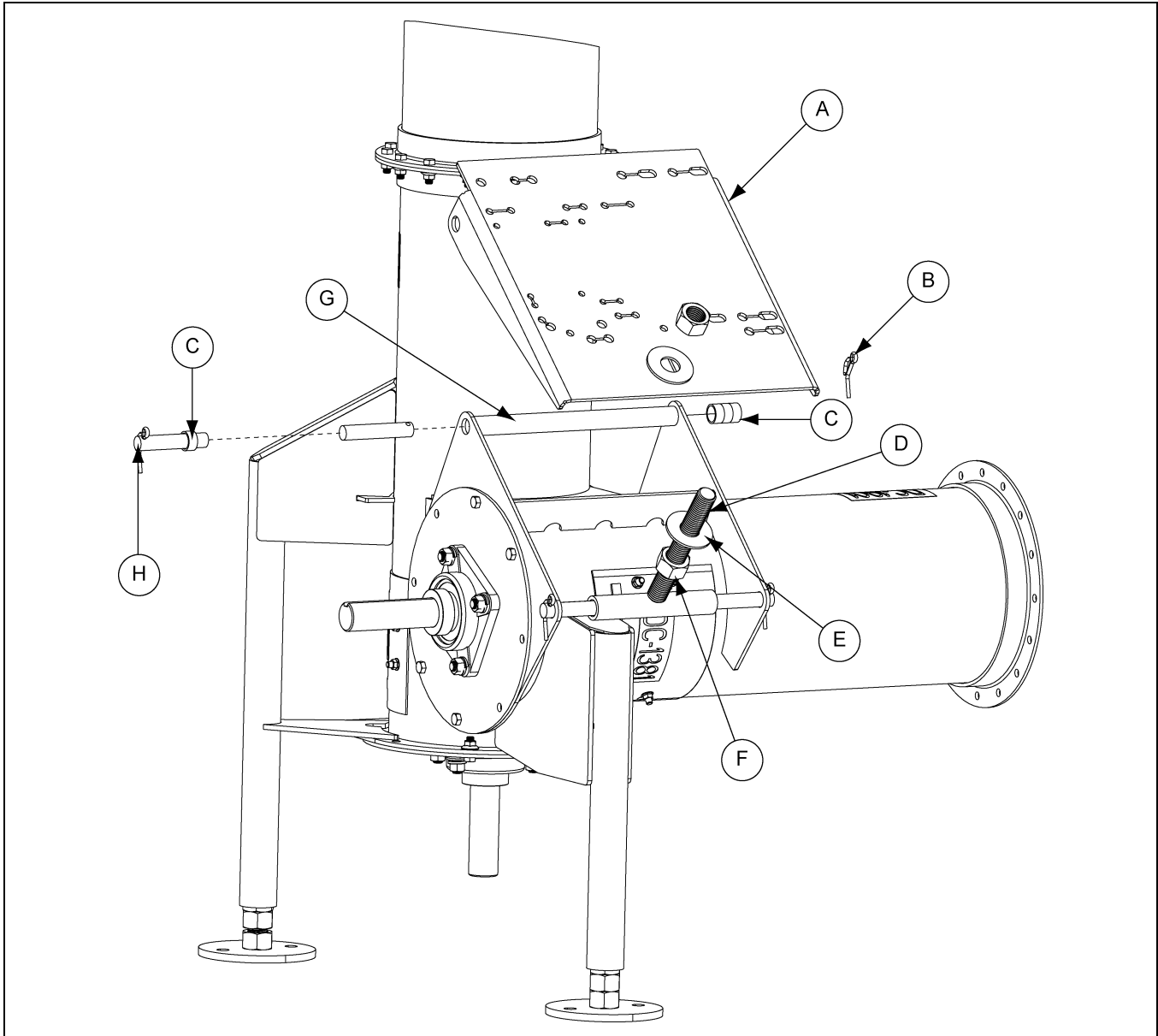

Figure 3H

Ref #	Description
A	Motor Mount Plate
B	3/16" x 2" Cotter Pin
C	Spacers
D	Threaded Rod

Ref #	Description
E	Motor Mount Adjustment Washer
F	Motor Mount Adjustment Nut
G	Pivot Tube
H	Motor Mount Pivot Rod

### 3. Installation

## Installing the Motor Mount Plate (Continued)

C. Slide the *motor mount pivot rod (H)* through the pivot tube (F) on the cross-tube assembly.

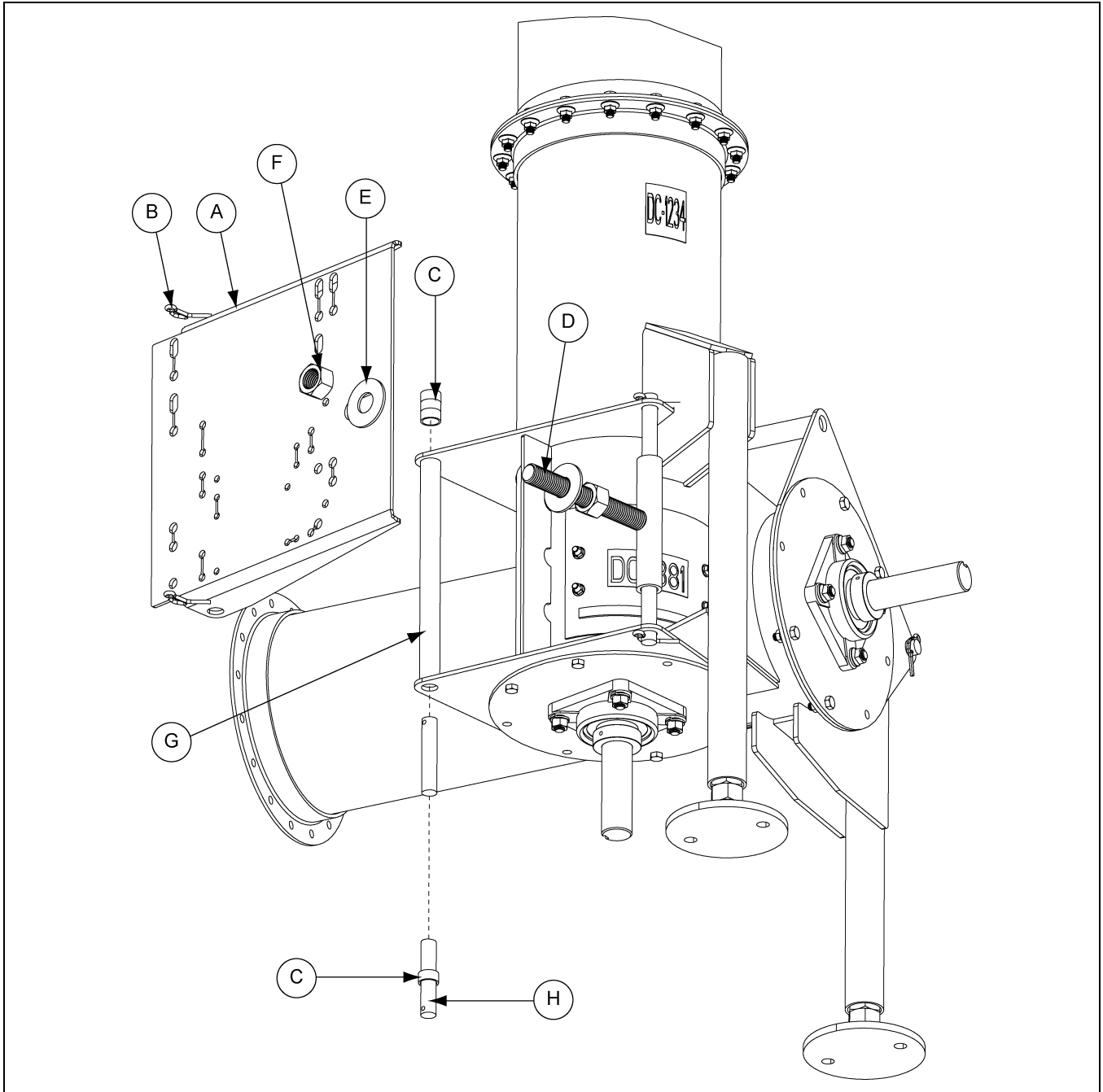

Figure 3I

Ref #	Description
A	Motor Mount Plate
B	3/16" x 2" Cotter Pin
C	Spacers
D	Threaded Rod

Ref #	Description
E	Motor Mount Adjustment Washer
F	Motor Mount Adjustment Nut
G	Pivot Tube
H	Motor Mount Pivot Rod

## Installing the Motor Mount Plate (Continued)

D. When the *pivot rod* begins to extend through the pivot tube, install the *spacers* BETWEEN the back plate and the inner face of the *motor mount plate*. (See [Figure 3J](#) below and [Figure 3K](#) on Page 20.)

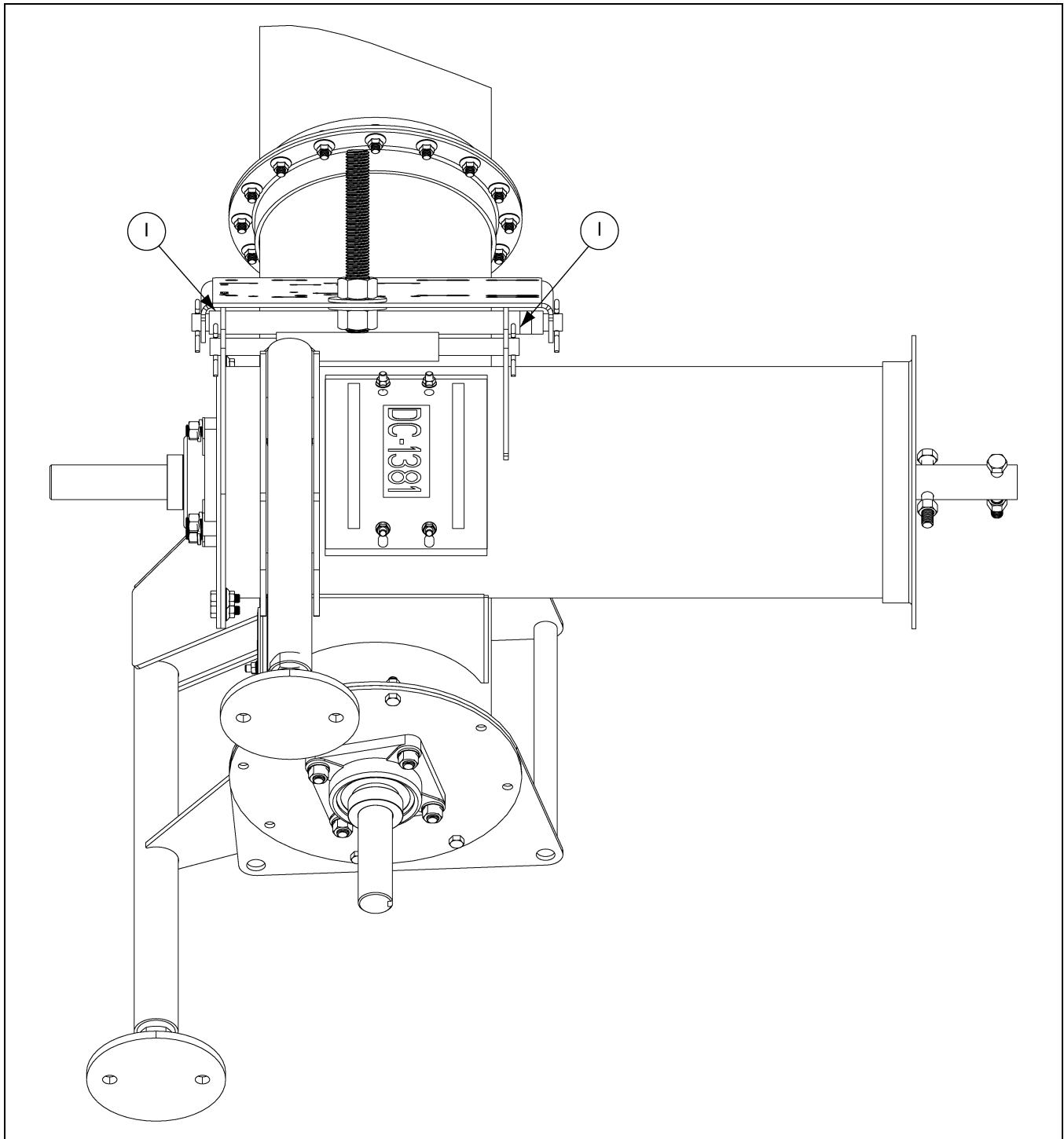

Figure 3J

Ref #	Description
I	Temporary spacer placement on horizontal section.

### 3. Installation

## Installing the Motor Mount Plate (Continued)

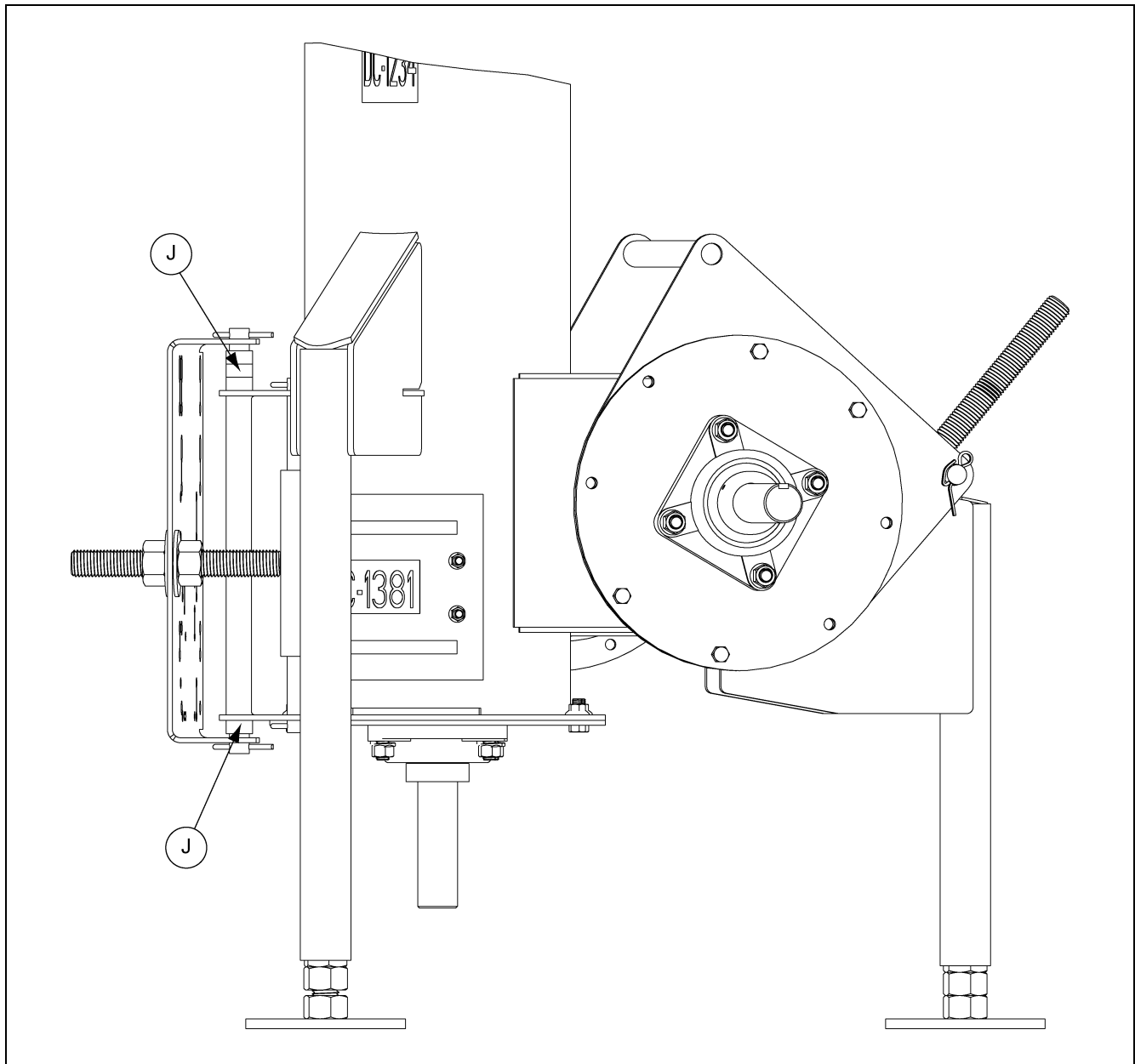

Figure 3K

Ref #	Description
J	Temporary spacer placement on Vertical section.

E. Secure the *motor mount pivot rod* in place with two (2) 3/16" x 2" cotter pins. With the cotter pins in the *pivot rod*, bend one tab of the cotter pin back so that it touches the pivot rod and bend the other tab of the cotter pin away from the first tab.

F. Loosely install the *upper motor mount adjustment washer and nut* onto the *threaded rod*, over the *motor mount plate*.

**NOTE:** *The number of spacers will vary between each size of vertical unload.*

## Installing the Belt Guard Brackets

- A. Align the slots on the *belt guard mounting brackets* (B) with the open holes on the *bearing plate* (A).
- B. Secure each *bracket* with the appropriate hex bolts (C), flat washers (D) and serrated flange nuts (E).  
(See *Figure 3L* below and *Figure 3M* on Page 22.)

Belt Guard Bracket Attachment Hardware Size	
8"	Four (4) 5/16" x 1" Grade 5 Hex Bolts, Flat Washers and Serrated Flange Nuts
10" and 12"	Four (4) 3/8" x 1-1/4" Grade 5 Hex Bolts, Flat Washers and Serrated Flange Nuts

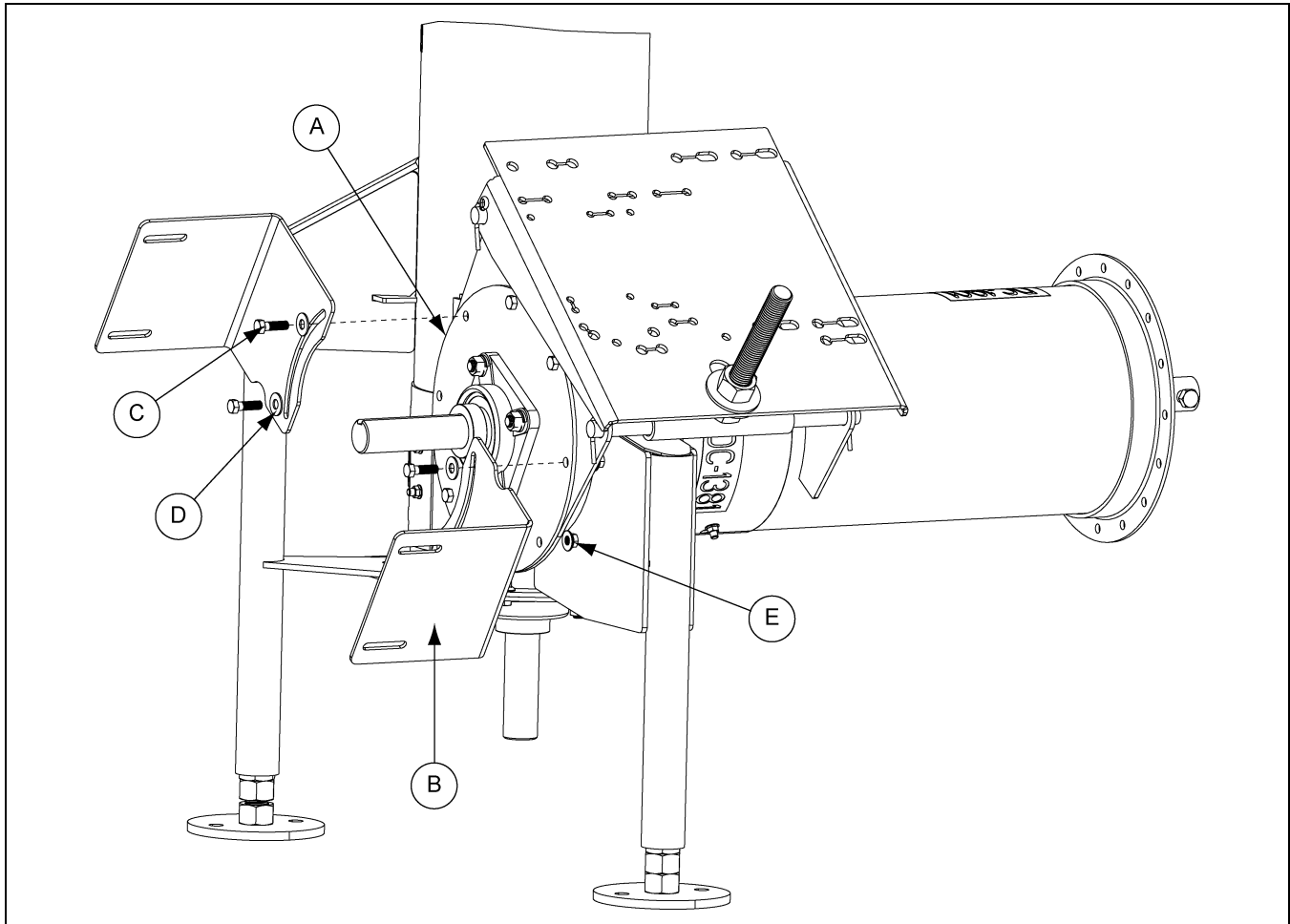

Figure 3L

Ref #	Description
A	Bearing Plate
B	Belt Guard Mounting Bracket
C	Hex Bolt
D	Flat Washer
E	Serrated Flange Nut

Installing the Belt Guard Brackets (Continued)

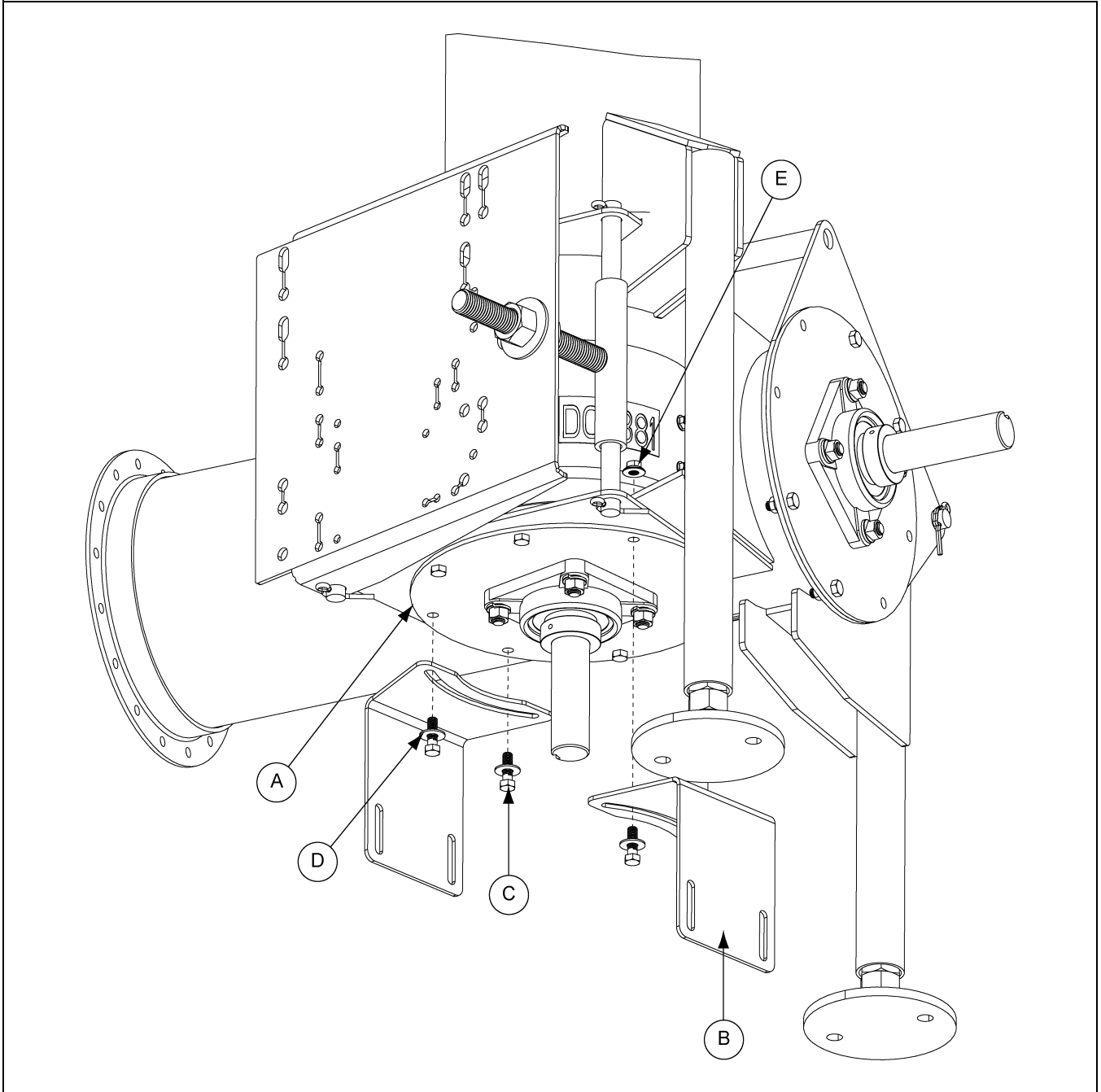

Figure 3M

Ref #	Description
A	Bearing Plate
B	Belt Guard Mounting Bracket
C	Hex Bolt
D	Flat Washer
E	Serrated Flange Nut

## Installing the Pulley

- A. Place and position the *key (D)* into the keyway located on the *drive shaft (C)*.
- B. If applicable, assemble the supplied *sheave bushing (B)* to the *flight pulley (A)*. Place the *flight pulley (A)* onto the *drive shaft (C)* with the set screw side of the *flight pulley (A)* facing away from the bearing plate. Position the *flight pulley (A)* close to the lock collar, but ensure it is not in contact.
- C. Once the *pulley* is appropriately positioned, tighten the set screw with a hex head wrench to secure it to the *drive shaft (C)*. (See [Figure 3N](#) below and [Figure 3O](#) on Page 24.)

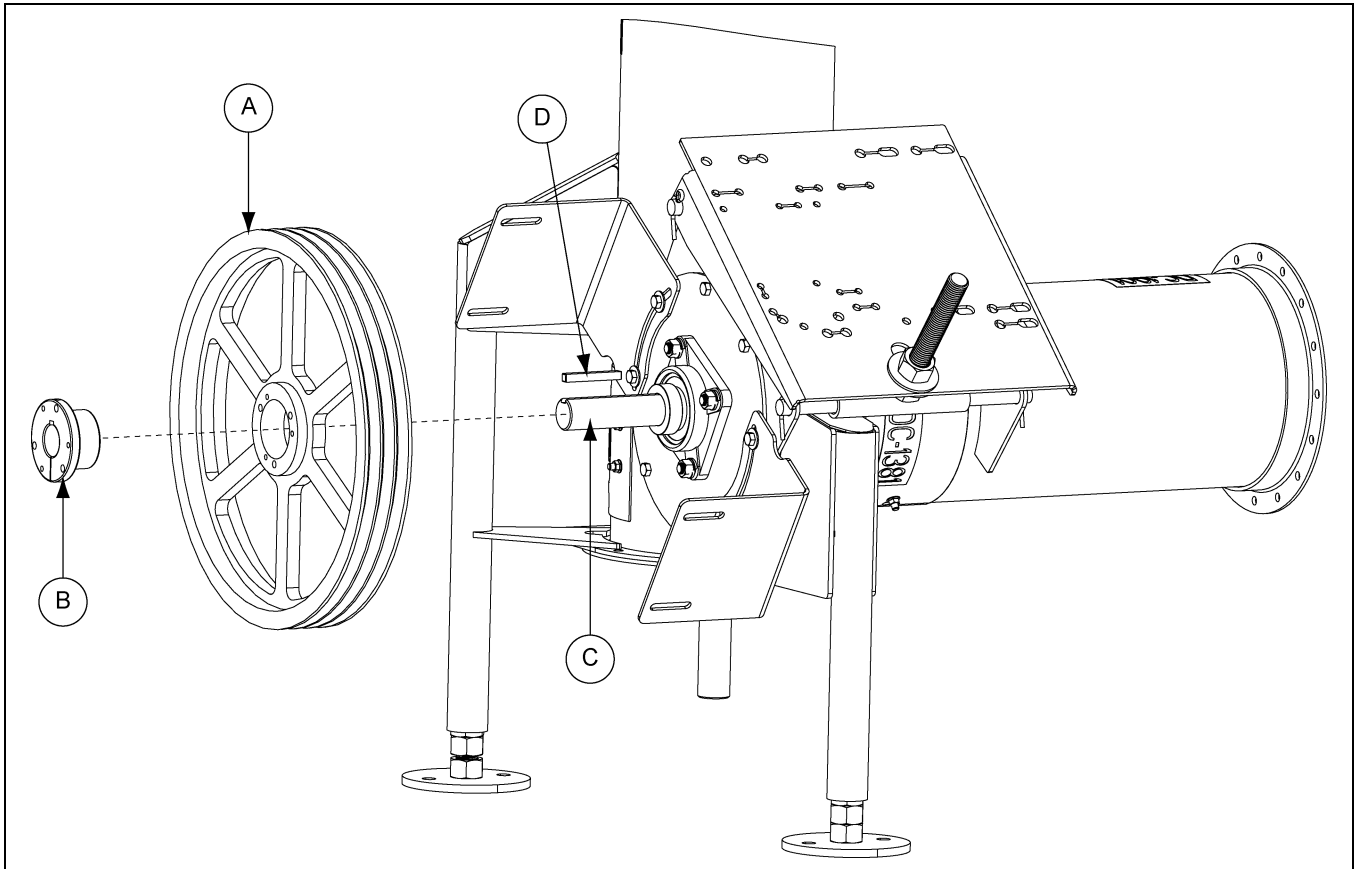

Figure 3N

Ref #	Description
A	Flight Pulley
B	Sheave Bushing
C	Drive Shaft
D	Key

### Installing the Pulley (Continued)

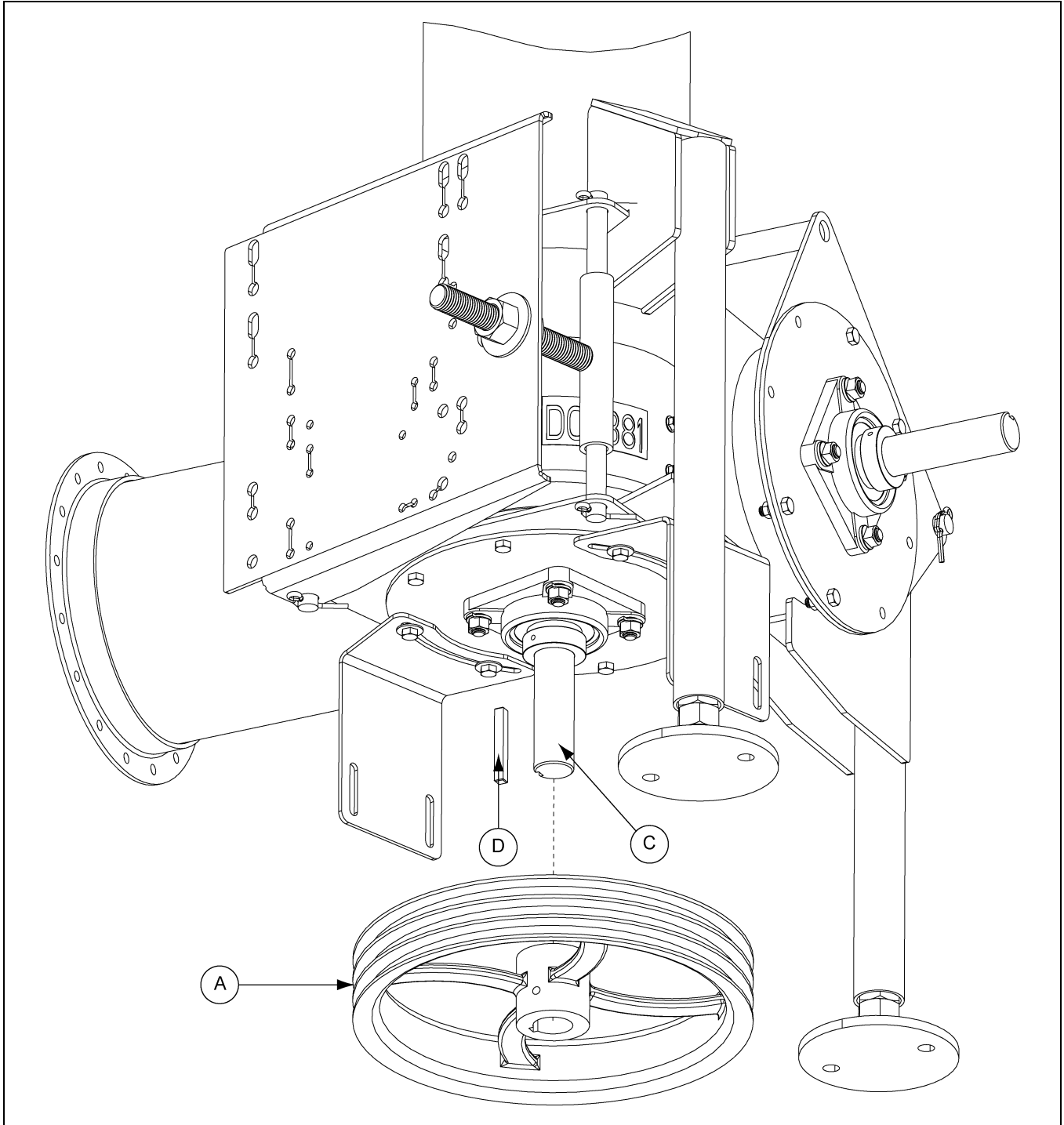

Figure 30

Ref #	Description
A	Flight Pulley
C	Drive Shaft
D	Key



## Installing the Motor (Not Provided)

- A. Attach the motor to the motor mount plate using appropriate bolts, lock washers and hex nuts. (See Chart Below.)

**Motor Bolt Selection**

Motor Frame	Hex Bolt Size	Qty
56	5/16"-18 x 1-1/4"	4
143T		
145T		
182T	3/8"-16 x 1-1/4"	4
184T		
213T		
215T		
254T	1/2"-13 x 1-3/4"	4
256T		

- B. Install pulley onto motor shaft and make sure that it is aligned with the flight pulley. It may be necessary to move spacers to gain shaft alignment. (See Figure 3P below and Figure 3Q on Page 26.)

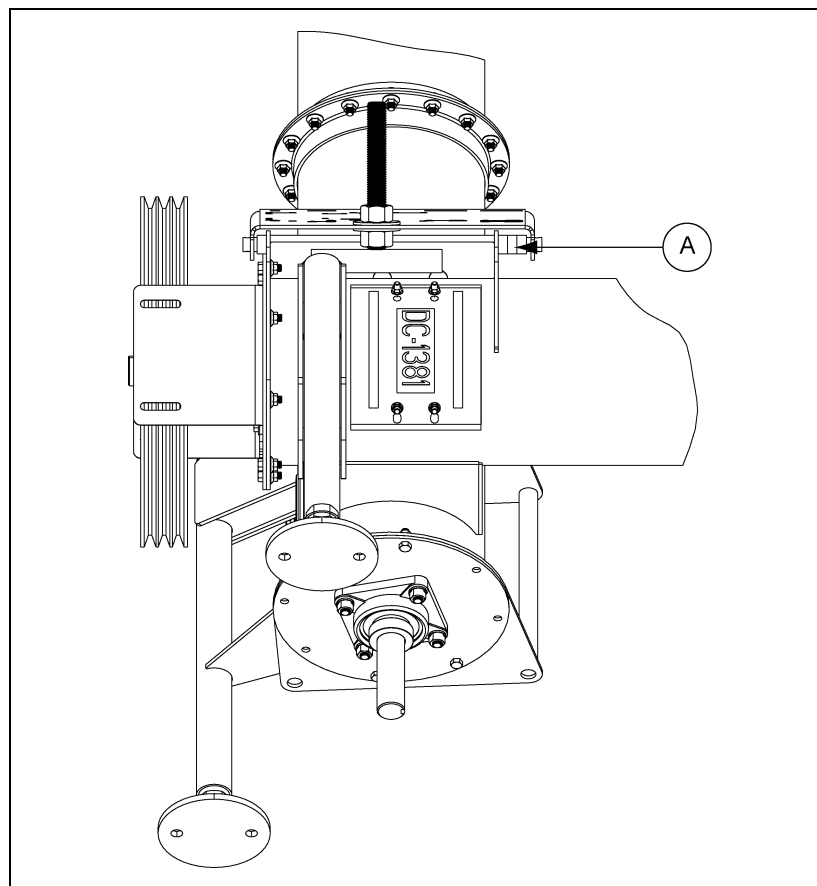

**Figure 3P**

Ref #	Description
A	Adjust spacers as needed to align pulleys.

## Installing the Motor (Continued)

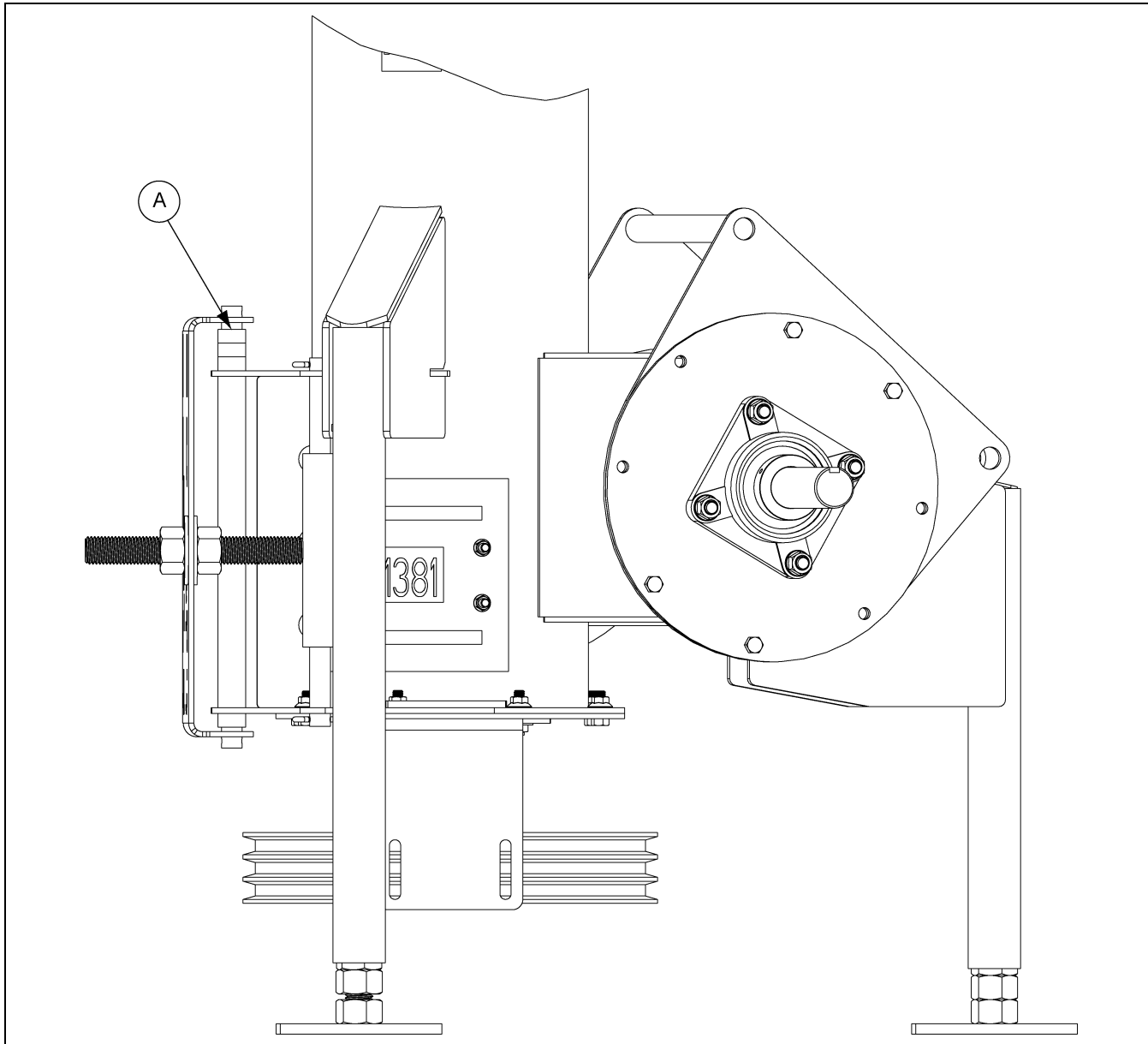

Figure 3Q

Ref #	Description
A	Adjust spacers as needed to align pulleys.

## Installing the Belts

- A. Place the belts onto the pulleys.
- B. Screw the *lower motor mount adjustment nut* upward, raising the *motor mount plate* and putting tension on the belts.
- C. Once the desired tension is reached, tighten the *upper motor mount adjustment nut* down onto the *motor mount plate*, thereby locking it into place.

## Installing the Belt Guard

- A. With the belts properly tensioned, remove the *bottom belt guard cover (C)* and slip the *belt guard (A)* down over the *motor shaft* and the *flight pulley*.
- B. Bolt the *belt guard (A)* to the *belt guard mounting brackets (B)* using four (4)  $3/8"$  x  $1"$  flange bolts (D). The *belt guard mounting brackets (B)* should still be loose at this time.
- C. Align the *belt guard's* slot with the *motor shaft* and the *flight drive shaft*, making sure that the belt guard does not come into contact with either of the *pulleys*. Tighten down the *belt guard mounting brackets (B)* to the *bearing plate*. (See [Figure 3R](#) below and [Figure 3S](#) on Page 28.)

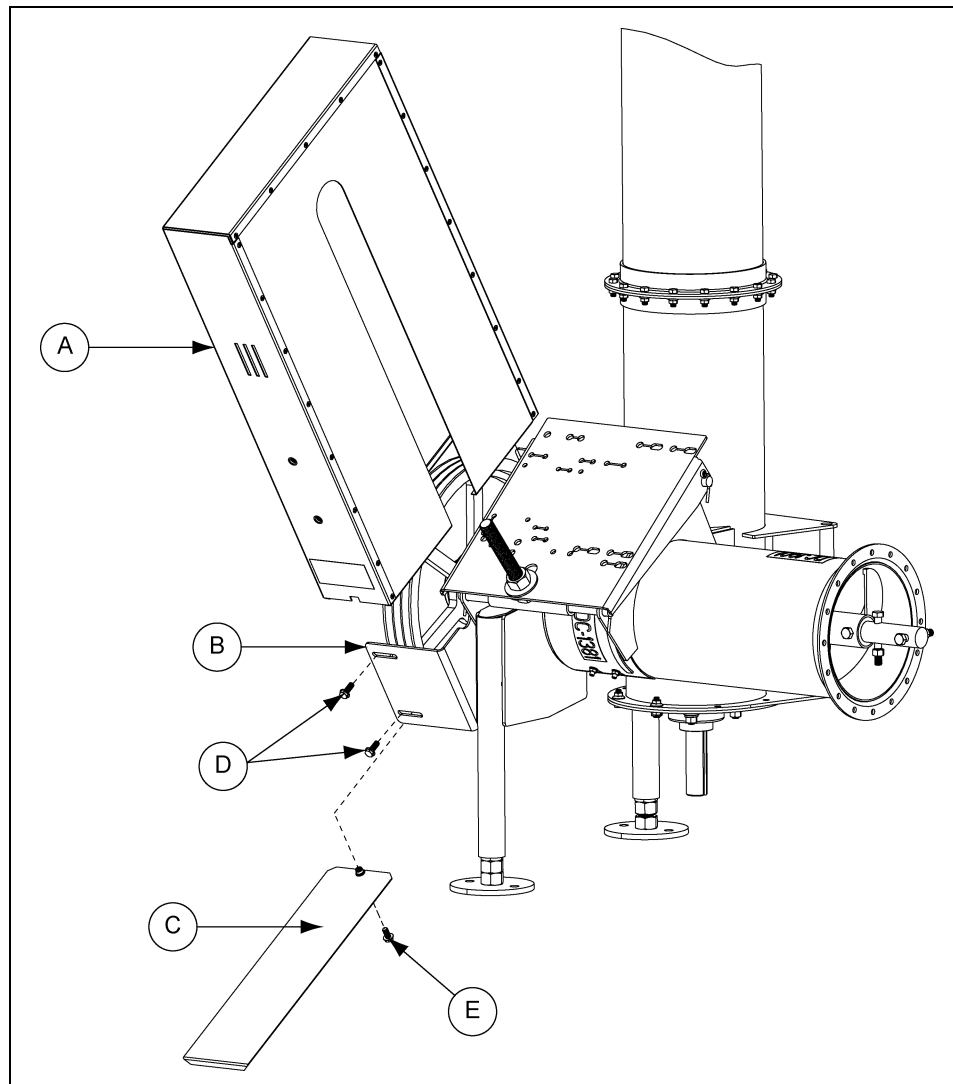

Figure 3R

Ref #	Description
A	Belt Guard
B	Belt Guard Mounting Bracket
C	Bottom Belt Guard Cover
D	$3/8"$ x $1"$ Flange Bolts
E	$3/8"$ x $3/4"$ Flange Bolt

## Installing the Belt Guard (Continued)

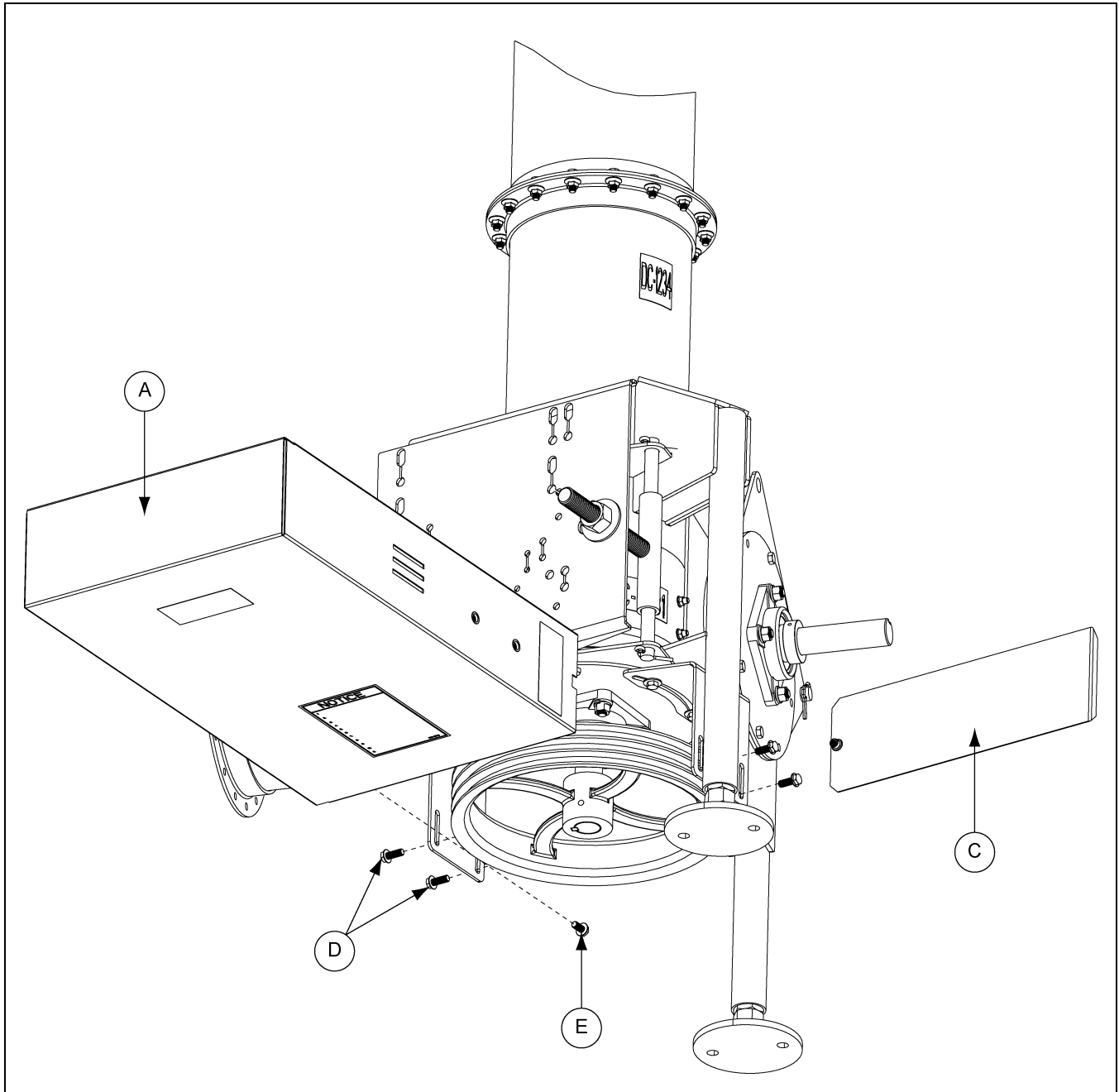

Figure 3S

Ref #	Description
A	Belt Guard
C	Bottom Belt Guard Cover
D	3/8" x 1" Flange Bolts
E	3/8" x 3/4" Flange Bolt

D. Once the *brackets* are tightened, slide the *bottom belt guard cover* back into place and secure with a 3/8" x 3/4" flange bolt (E).

## Installing the Vertical Motor Cover

- A. After both *belt guards* are installed, the *vertical motor cover* (A) can be attached.
- B. Use two (2) 1/2" x 1-1/4" flange bolts (C), through the holes on the *vertical motor cover* (A) and attach them to the 1/2" serrated flange nuts (B), in the slots at the top of the *motor mount plate*.

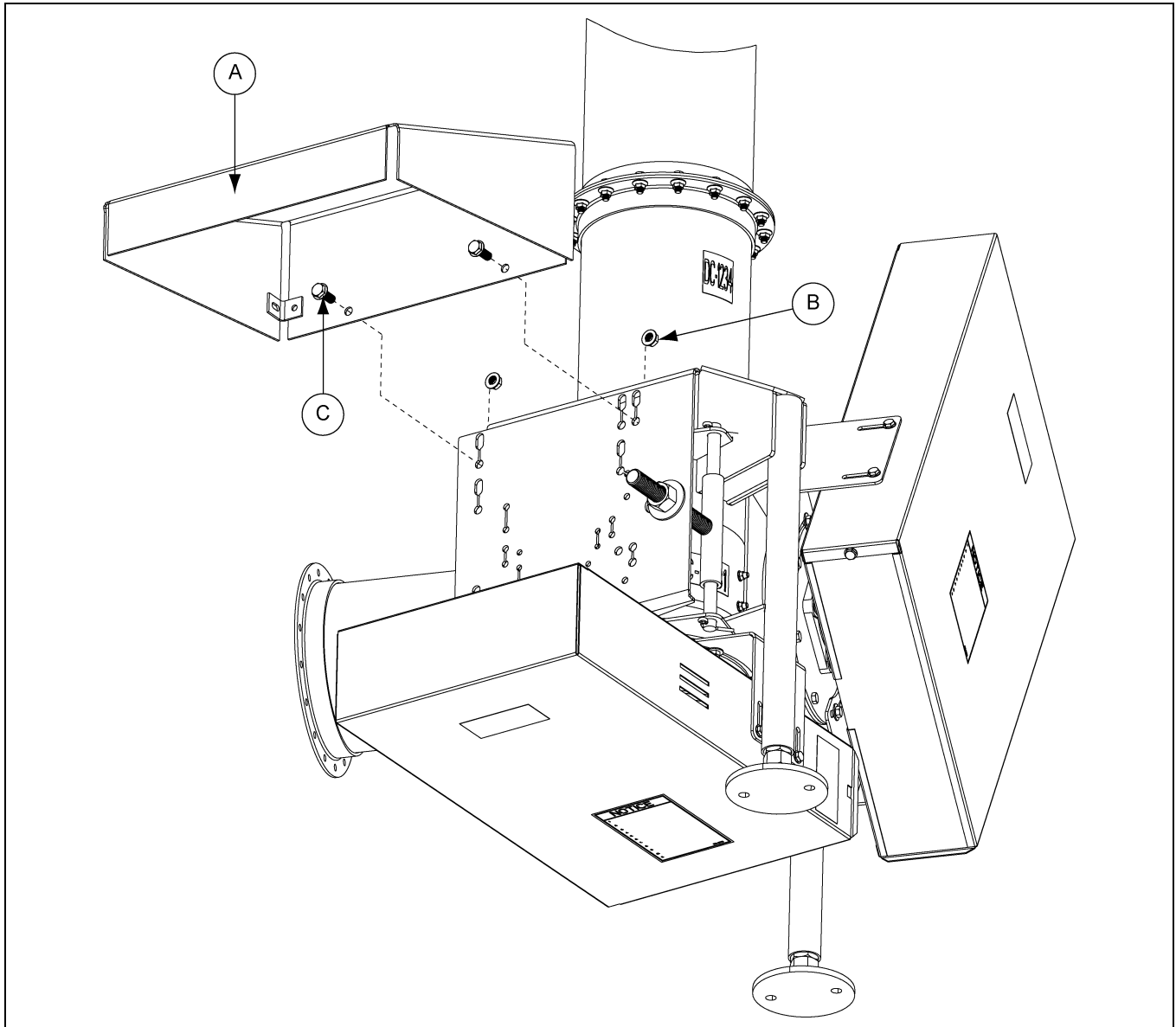

Figure 3T

Ref #	Description
A	Vertical Motor Cover
B	1/2" Serrated Flange Nut
C	1/2" x 1-1/4" Flange Bolt

- C. Adjust the *vertical motor cover* (A) up or down in the slots, making sure that there is adequate clearance between the inside of the *vertical motor cover* (A) and the top of the *vertical motor housing*.
- D. After there is adequate clearance, tighten the flange bolts (C) and serrated flange nuts (D).

### 3. Installation

## Electric Motor Drive Selection



**A qualified electrician must install electrical controls and wiring. The motor disconnect switches and conductor cables must comply with the National Electrical Code and any local codes which apply. Reset and motor starting stations should be located so that the operator can see that all personnel are clear of the equipment.**

- A. Use the bin size and the length of horizontal flight being to determine horsepower required for the job.
- B. Use the tables on the following pages to determine the size of motor required. Use a larger motor when encountering high moisture or when high capacity is required. (See Chart on Pages 32 and 33.)
- C. The following horsepower recommendations are for moving fairly dry grain. Use an electric motor of the proper size that operates at 1750 RPM. Motor pulleys are not furnished with the auger. (See Chart on Pages 32 and 33.)

**8" Flight Chart**

Product #	Part #	Description	Bin Diameter	Unloader HP	
				Horizontal	Vertical
GFC82400	GK1799	14'-6" x 7" O.D. Flight	24'	<b>3</b>	<b>5</b>
GFC82700	GK1800	16'-0" x 7" O.D. Flight	27'		
GFC83000	GK1801	17'-6" x 7" O.D. Flight	30'		
GFC83300	GK1802	19'-6" x 7" O.D. Flight	33'-34'		
GFC83600	GK1803	20'-6" x 7" O.D. Flight	36'		
GFC83800	GK1804	22'-6" x 7" O.D. Flight	37'-39'		
GFC84000	GK1805	23'-0" x 7" O.D. Flight	40'		
GFC84200	GK1806	24'-0" x 7" O.D. Flight	42'		
GFC84800	GK1807	7'-0" x 7" O.D. Flight (Intake)	48'-49'	<b>5</b>	
	GK1808	20'-0" x 7" O.D. Flight (Discharge)			
GFC85400	GK5878	10'-0" x 7" O.D. Flight (Intake)	54'-55'		
	GK1808	20'-0" x 7" O.D. Flight (Discharge)			
GFC86000	GK1810	13'-0" x 7" O.D. Flight (Intake)	60'		
	GK1808	20'-0" x 7" O.D. Flight (Discharge)			
GFC86300	GK5880	14'-6" x 7" O.D. Flight (Intake)	63'		
	GK1808	20'-0" x 7" O.D. Flight (Discharge)			
GFC86800	GK5881	17'-6" x 7" O.D. Flight (Intake)	68'-69'	<b>7-1/2</b>	
	GK1808	20'-0" x 7" O.D. Flight (Discharge)			
GFC87200	GK5882	19'-0" x 7" O.D. Flight (Intake)	72'		
	GK1808	20'-0" x 7" O.D. Flight (Discharge)			
GFC87500	GK5883	20'-6" x 7" O.D. Flight (Intake)	75'		
	GK1808	20'-0" x 7" O.D. Flight (Discharge)			
GFC87800	GK5884	22'-6" x 7" O.D. Flight (Intake)	78'		
	GK1808	20'-0" x 7" O.D. Flight (Discharge)			
GFC88000	GK5885	4'-6" x 7" O.D. Flight (Intake)	80'		
	GK1130	20'-0" x 7" O.D. Flight (Intermediate)			
	GK1808	20'-0" x 7" O.D. Flight (Discharge)			
GFC88200	GK5886	5'-6" x 7" O.D. Flight (Intake)	82'	<b>10</b>	
	GK1130	20'-0" x 7" O.D. Flight (Intermediate)			
	GK1808	20'-0" x 7" O.D. Flight (Discharge)			
GFC89000	GK5887	9'-6" x 7" O.D. Flight (Intake)	90'		
	GK1130	20'-0" x 7" O.D. Flight (Intermediate)			
	GK1808	20'-0" x 7" O.D. Flight (Discharge)			
GFC89200	GK5888	10'-6" x 7" O.D. Flight (Intake)	92'		
	GK1130	20'-0" x 7" O.D. Flight (Intermediate)			
	GK1808	20'-0" x 7" O.D. Flight (Discharge)			

## 10" Flight Chart

Product #	Part #	Description	Bin Diameter	Unloader HP	
				Horizontal	Vertical
GFC10240	GK1826	14'-6" x 9" O.D. Flight	24'	5	
GFC10270	GK1827	16'-0" x 9" O.D. Flight	27'		
GFC10300	GK1828	17'-6" x 9" O.D. Flight	30'		
GFC10330	GK1829	19'-6" x 9" O.D. Flight	33'-34'		
GFC10360	GK1830	20'-6" x 9" O.D. Flight	36'	7-1/2	
GFC10380	GK1831	22'-6" x 9" O.D. Flight	37'-39'		
GFC10400	GK1832	23'-0" x 9" O.D. Flight	40'		
GFC10420	GK1833	24'-0" x 9" O.D. Flight	42'		
GFC10480	GK1834	7'-0" x 9" O.D. Flight (Intake)	48'-49'		
	GK1835	20'-0" x 9" O.D. Flight (Discharge)			
GFC10540	GK1836	10'-0" x 9" O.D. Flight (Intake)	54'-55'		
	GK1835	20'-0" x 9" O.D. Flight (Discharge)			
GFC10600	GK1837	13'-0" x 9" O.D. Flight (Intake)	60'	10	
	GK1835	20'-0" x 9" O.D. Flight (Discharge)			
GFC10630	GK1838	14'-6" x 9" O.D. Flight (Intake)	63'		
	GK1835	20'-0" x 9" O.D. Flight (Discharge)			
GFC10680	GK1839	17'-6" x 9" O.D. Flight (Intake)	68'-69'		
	GK1835	20'-0" x 9" O.D. Flight (Discharge)			
GFC10720	GK1840	19'-0" x 9" O.D. Flight (Intake)	72'		
	GK1835	20'-0" x 9" O.D. Flight (Discharge)			
GFC10750	GK1841	20'-6" x 9" O.D. Flight (Intake)	75'		
	GK1835	20'-0" x 9" O.D. Flight (Discharge)			
GFC10780	GK1842	22'-6" x 9" O.D. Flight (Intake)	78'		
	GK1835	20'-0" x 9" O.D. Flight (Discharge)			
GFC10800	GK1843	4'-6" x 9" O.D. Flight (Intake)	80'	15	
	GK1844	20'-0" x 9" O.D. Flight (Intermediate)			
	GK1835	20'-0" x 9" O.D. Flight (Discharge)			
GFC10820	GK1845	5'-6" x 9" O.D. Flight (Intake)	82'		
	GK1844	20'-0" x 9" O.D. Flight (Intermediate)			
	GK1835	20'-0" x 9" O.D. Flight (Discharge)			
GFC10900	GK1846	9'-6" x 9" O.D. Flight (Intake)	90'		
	GK1844	20'-0" x 9" O.D. Flight (Intermediate)			
	GK1835	20'-0" x 9" O.D. Flight (Discharge)			
GFC10920	GK1847	10'-6" x 9" O.D. Flight (Intake)	92'		
	GK1844	20'-0" x 9" O.D. Flight (Intermediate)			
	GK1835	20'-0" x 9" O.D. Flight (Discharge)			

### 3. Installation

#### 12" Flight Chart

Product #	Part #	Description	Bin Diameter	Unloader HP	
				Horizontal	Vertical
GFC12240	GK2518	14'-6" x 11" O.D. Flight	24'	7-1/2	
GFC12270	GK1849	16'-0" x 11" O.D. Flight	27'		
GFC12300	GK2519	17'-6" x 11" O.D. Flight	30'		
GFC12330	GK1851	19'-6" x 11" O.D. Flight	33'-34'		
GFC12360	GK2520	20'-6" x 11" O.D. Flight	36'		
GFC12380	GK1853	22'-6" x 11" O.D. Flight	37'-39'		
GFC12400	GK1859	14'-7" x 11" O.D. Flight (Intake)	40'	10	
	GK2559	8'-5" x 11" O.D. Flight (Discharge)			
GFC12420	GK1855	5'-7" x 11" O.D. Flight (Intake)	42'		
	GK1854	18'-5" x 11" O.D. Flight (Discharge)			
GFC12480	GK1856	9'-7" x 11" O.D. Flight (Intake)	48'-49'		
	GK1854	18'-5" x 11" O.D. Flight (Discharge)			
GFC12540	GK1858	11'-7" x 11" O.D. Flight (Intake)	54'-55'		
	GK1854	18'-5" x 11" O.D. Flight (Discharge)			
GFC12600	GK1859	14'-7" x 11" O.D. Flight (Intake)	60'	15	10
	GK1854	18'-5" x 11" O.D. Flight (Discharge)			
GFC12630	GK1848	16'-1" x 11" O.D. Flight (Intake)	63'		
	GK1854	18'-5" x 11" O.D. Flight (Discharge)			
GFC12680	GK1850	19'-1" x 11" O.D. Flight (Intake)	68'-69'		
	GK1854	18'-5" x 11" O.D. Flight (Discharge)			
GFC12720	GK1860	20'-7" x 11" O.D. Flight (Intake)	72'		
	GK1854	18'-5" x 11" O.D. Flight (Discharge)			
GFC12750	GK1852	22'-1" x 11" O.D. Flight (Intake)	75'		
	GK1854	18'-5" x 11" O.D. Flight (Discharge)			
GFC12780	GK1822	4'-1" x 11" O.D. Flight (Intake)	78'		
	GK1857	20'-0" x 11" O.D. Flight (Intermediate)			
	GK1854	18'-5" x 11" O.D. Flight (Discharge)			
GFC12800	GK1864	6'-1" x 11" O.D. Flight (Intake)	80'		
	GK1857	20'-0" x 11" O.D. Flight (Intermediate)			
	GK1854	18'-5" x 11" O.D. Flight (Discharge)			
GFC12820	GK1816	7'-1" x 11" O.D. Flight (Intake)	82'		
	GK1857	20'-0" x 11" O.D. Flight (Intermediate)			
	GK1854	18'-5" x 11" O.D. Flight (Discharge)			
GFC12900	GK1906	11'-1" x 11" O.D. Flight (Intake)	90'	20	
	GK1857	20'-0" x 11" O.D. Flight (Intermediate)			
	GK1854	18'-5" x 11" O.D. Flight (Discharge)			
GFC12920	GK1907	12'-1" x 11" O.D. Flight (Intake)	92'		
	GK1857	20'-0" x 11" O.D. Flight (Intermediate)			
	GK1854	18'-5" x 11" O.D. Flight (Discharge)			
GFC12105	GK1910	18'-7" x 11" O.D. Flight (Intake)	105'		
	GK1857	20'-0" x 11" O.D. Flight (Intermediate)			
	GK1854	18'-5" x 11" O.D. Flight (Discharge)			
GFC12113	GK1911	22'-7" x 11" O.D. Flight (Intake)	113'		
	GK1857	20'-0" x 11" O.D. Flight (Intermediate)			
	GK1854	18'-5" x 11" O.D. Flight (Discharge)			
GFC12120	GK1864	6'-1" x 11" O.D. Flight (Intake)	120'		
	GK1857	20'-0" x 11" O.D. Flight (Intermediate)			
	GK1854	18'-5" x 11" O.D. Flight (Discharge)			



## Horizontal Drive

Auger	Part #	Motor Sheave Size	Flight Sheave		NEMA Motor Frame	Motor HP	Belt Size	Belt Quantity	Belt Type
			Size	RPM					
8"	CE-00566	3.5"	15"	409	182T and 184T	3-5 HP	56	2	B
	GK1346				213T and 215T	7-1/2 - 10 HP	57	3	
10"	MHC00743	3.75"	18.4"	357	184T	5 HP	65	2	BX
	MHC00485				213T and 215T	7-1/2 - 10 HP			
						254T	15 HP	67	
12"	MHC00020	3.75"	18.4"	357	213T and 215T	7-1/2 - 10 HP	68	2	BX
	MHC00486				254T and 256T	15-20 HP	70	3	

## Vertical Drive

Auger	Part #	Motor Sheave Size	Flight Sheave		NEMA Motor Frame	Motor HP	Belt Size	Belt Quantity	Belt Type
			Size	RPM					
8"	GK1346	5.0"	15"	584	184T	5 HP	57	2	B
10"	GK4441	4.0"	15"	467	213T	7-1/2 HP	59	3	B
12"	MHC01253	3.5"	15"	409	215T	10 HP	62	3	BX



**1750 RPM electric motors and controls shall be installed by a qualified electrician and must meet the standards set by the National Electrical Code and all local and state codes. Reset and motor starting controls shall be located where the operator has unrestricted access to the controls.**

- A. A magnetic starter should be used for the operator's protection and for the protection of the motor. This is to protect the operator against accidental restart caused by power interruption, conductor fault, low voltage, circuit interruption or motor overload. Therefore, the motor must be restarted manually. If using a motor with built-in thermal overload protection, make sure this type of motor has a manual reset.



**Disconnect and lock out power before resetting motor overloads. Ensure electric motors are grounded.**

### 3. Installation

## Perform Pre-Start Checks



***Failure to perform any or all of these pre-start checks may cause damage to the equipment and/or cause **SERIOUS INJURY** or **DEATH** to those in the work area. Failure to perform any or all of these pre-start checks may also be a misuse of the equipment. Any misuse of the equipment may void the warranty.***



***ALWAYS keep ALL guards and shields in place, until all the power is disconnected and locked out.***



***Make sure **ONLY** trained operators are in the work area before operating or moving the machine. Two (2) people must always be in a position where the operation of the equipment can be monitored.***

- A. Make sure ALL belts are properly tensioned.
- B. Make sure ALL shields are in place and that the belt(s) and pulley(s) can move freely.
- C. Inspect the drive unit for any problems or potential problems.
- D. Be aware of any emergency shut down procedures. Two (2) people must always be in a position where the operation of the equipment can be monitored.
- E. Before starting the auger for the first time, make sure that all parts are assembled correctly according to the instructions in this manual.
- F. The bin wall inside the bin should have a control gate. The gate should be closed before start-up.

## Start the Auger



***DO NOT start or stop the auger while it is under load. Doing so may cause the auger to “jam”.***



***Failures may occur if the auger is run full of grain before it has been “polished” during the “break-in” period.***



***NEVER operate the auger empty. Operating augers empty for any length of time will cause excessive wear.***



***Be aware of any unusual vibration or noises during the initial start-up and “break-in” period. If anything unusual is detected, immediately shut down the auger and disconnect and lock out the power supply before servicing.***



***Never operate the auger at speeds higher than recommended. Auger flights running in excess of recommended speeds will cause excessive wear.***

- A. Start the auger.
- B. If the auger is being used for the first time or for the first time of the season, run the auger through a “break-in” period. This “break-in” period consists of running the auger at half capacity until the screw becomes polished and smooth before attempting to run at full capacity.
- C. The bin wall inside the bin should have a control gate. The gate should be closed before start-up and closed before shut down to allow the machine to clean out.
- D. The controls for the control gate will either pull or push open, depending on the type of well being used. Use the control gate to regulate a flow of less than full capacity until several hundred bushels of grain have been run through the auger to polish the flight assembly and tube.
- E. Do not stop or start augers under load, especially before the flight and tube become well polished, as this may cause the auger to “lock up”. Make sure to use the control gate as a flow control so the vertical auger cannot become plugged.

### 3. Installation

## Operate the Auger

**NOTE:** *The auger capacity can fluctuate greatly under varying conditions. Moisture content, different commodities, amount of foreign matter and speeds, all play a part in the performance of the auger. Twenty five percent (25%) moisture may cut capacity by as much as 40% under some conditions.*

- A. Ensure there are at least two (2) people in the work area to monitor operations at all times.
- B. Visually inspect the auger periodically during operation.



***Be alert for any unusual vibrations, noises and the loosening of any fasteners. If anything unusual is detected, immediately shut down the auger, disconnect and lock out the power source before servicing.***

- C. When augers are stopped and restarted under full load, it may damage the auger. Using a larger diameter auger and reducing its load level will be far better than subjecting a smaller diameter auger to big loads. If the auger is kept from complete filling, it will make start-up easier and will convey more efficiently.

## Normal Shut Down

- A. Before shutting down the unit, make sure that bin wall and unloading tubes are empty.
- B. Disconnect and lock out the power source before leaving the work area.

## Emergency Shut Down

- A. Know how to shut down the auger in case of an emergency.
- B. Disconnect and lock out the power source.
- C. Do not restart the auger under load.
- D. Close the bin wall control gates.
- E. Clear out as much grain from the auger and hopper as possible.
- F. Unlock and reconnect the power source.
- G. Gradually clear the auger until there is no grain or obstruction.



***NEVER restart when under a full load. Starting unit under load may damage the machine. Such damage is considered abuse of the equipment.***

## Lock Out

- A. Always stop and disconnect the power source whenever the operator must leave the work area or for maintenance of the machinery.
- B. Make sure no one can operate the unload auger while the operator is not in the work area.



*Use the type of main power disconnect switch that is capable of being locked only in the OFF position.*

## Storage Preparation

- A. Close all wells to discharge auger.
- B. Be sure the unload tube is empty.
- C. Shut down the auger.
- D. Make sure power source is locked out and disconnected.
- E. Make sure all fasteners are tight.

## Maintenance



*ALWAYS shut down, lock out and disconnect the power supply before adjusting, servicing or cleaning the equipment.*

- A. Use CAUTION when repairing or replacing equipment parts.
- B. Make sure ALL decals are legible and firmly adhered to the auger. If necessary, replace them **FREE OF CHARGE** by contacting your dealer or the manufacturer.
- C. Ensure that ALL electric motors, etc., are operating at the proper speed.
- D. Maintain proper tension on the belt(s).
- E. Mount controls for any electric motors at a safe distance from the machine and in a location accessible in case of an emergency.
- F. Make sure ALL electrical wiring is not damaged and that it meets proper wiring codes.
- G. Make sure ALL components are in good working condition before use.
- H. Check the auger flight to make sure it is in good working condition.
- I. Grease the bearings at least two (2) times each season.

---

# NOTES

1. 8" Top of Vertical Bin Unloader Parts - [\(See Pages 40-41.\)](#)
2. 10" Top of Vertical Bin Unloader Parts - [\(See Pages 42-43.\)](#)
3. 12" Top of Vertical Bin Unloader Parts - [\(See Pages 44-45.\)](#)
4. 8" Horizontal Drive Parts - [\(See Pages 46-47.\)](#)
5. 10" Horizontal Drive Parts - [\(See Pages 48-49.\)](#)
6. 12" Horizontal Drive Parts - [\(See Pages 50-51.\)](#)
7. 8" Vertical Drive Parts - [\(See Pages 52-53.\)](#)
8. 10" Vertical Drive Parts - [\(See Pages 54-55.\)](#)
9. 12" Vertical Drive Parts - [\(See Pages 56-57.\)](#)

# 8" Top of Vertical Bin Unloader Parts

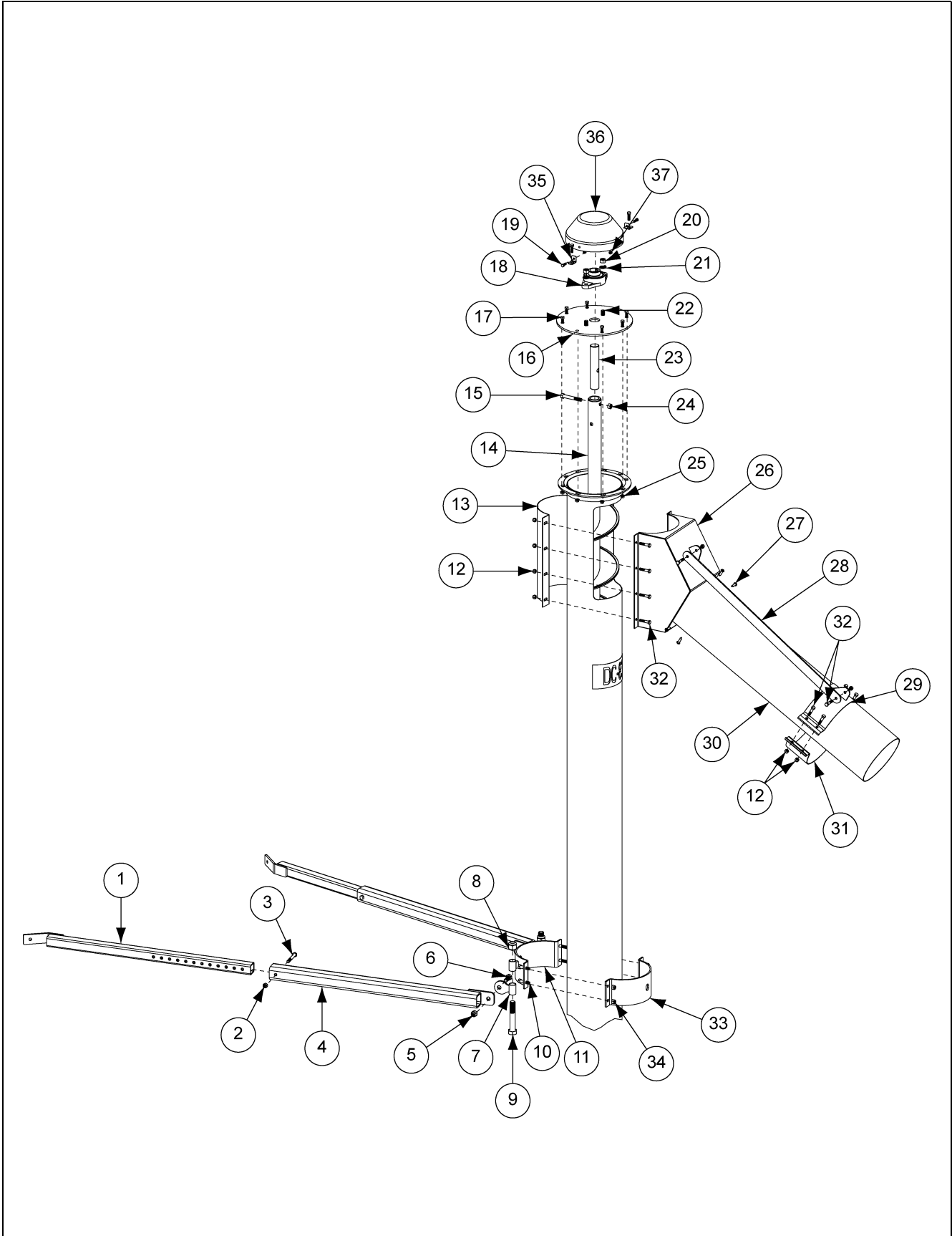



## 8" Top of Vertical Bin Unloader Parts List

Ref #	Part #	Description
1	GK7443	<b>Inner Support Leg</b>
2	S-7383	<b>Leg Adjustment Nut</b> - 3/8"-16 Nylock Lock Nut Zinc Grade 5
3	S-8988	<b>Leg Adjustment Bolt</b> - 3/8"-16 x 2-3/4" HHCS Bolt Zinc Grade 5
4	GK7318	<b>Outer Support Leg</b>
5	S-8260	<b>Leg Attachment Nut</b> - 1/2"-13 Nylock Lock Nut Zinc Grade 5
6	S-7534	<b>Leg Attachment Bolt</b> - 1/2"-13 x 1-1/4" HHCS Bolt Zinc Grade 2
7	GK7536	<b>Leg Support Bracket</b>
8	S-7217	3/4"-10 Nylock Lock Nut Zinc Grade 5
9	S-8063	3/4"-10 x 4-1/2" HHCS Zinc Grade 5
10	S-7515	<b>Half Band Attachment Bolt</b> - 3/8"-16 x 1-1/2" Hex Bolt Stainless Steel
11	GK7870	<b>Mounting Bracket Pivot Band</b>
12	S-7382	5/16"-18 Nylock Nut Zinc Grade 5
13	GK1505	<b>Connecting Band</b>
14	GK7426-2	<b>Vertical Flight</b>
15	S-8316	<b>Flight Bolt</b> - 7/16"-14 x 3" HHCS Zinc YDP Grade 8
16	GK7401	<b>Vertical Bearing Plate</b>
17	S-1196	<b>Bearing Plate Bolt</b> - 5/16"-18 x 1" HHCS Zinc Grade 5
18	GK1330	<b>Bearing</b>
19	S-1429	<b>Cap Bracket Bolt</b> - 1/4"-20 x 3/4" Zinc Grade 5
20	S-3729	<b>Bearing Nut</b> - 1/2"-13 Hex Nut YDP Grade 5
21	S-236	<b>Bearing Lock Washer</b> - 1/2" Lock Washer Zinc
22	S-8760	<b>Bearing Bolt</b> - 1/2"-13 x 1-1/2" HHCS Zinc Grade 5
23	GK1012	<b>Stub Shaft</b>
24	S-8317	<b>Flight Nut</b> - 7/16"-14 Stover Nut Zinc Grade C
25	S-3611	<b>Bearing Plate Nut</b> - 5/16"-18 Serrated Flange Nut YDP Grade 2
26	GK7873	<b>60° Spout Weldment</b>
27	S-7229	<b>Spout Screw</b> - 1/4" x 1" Self-drilling Screw Hex Washer Head Zinc
28	GK7805	<b>Spout Support Arm</b>
29	GK7841	<b>Spout Support Band</b>
30	GC08175	<b>Spout Tube</b>
31	GK1059	<b>Half Band</b>
32	S-2741	5/16"-18 x 1-1/2" HHCS Bolt Grade 5
33	GK2616	<b>Half Band</b>
34	S-7383	<b>Half Band Nut</b> - 3/8"-16 Nylock Lock Nut Zinc Grade 5
35	GC12223	<b>Vertical Cap Bracket</b>
36	GK1011	<b>8" Vertical Cap</b>
37	S-7025	<b>Cap Bracket Nut</b> - 1/4"-20 Nylock Nut Zinc Grade 5

# 10" Top of Vertical Bin Unloader Parts

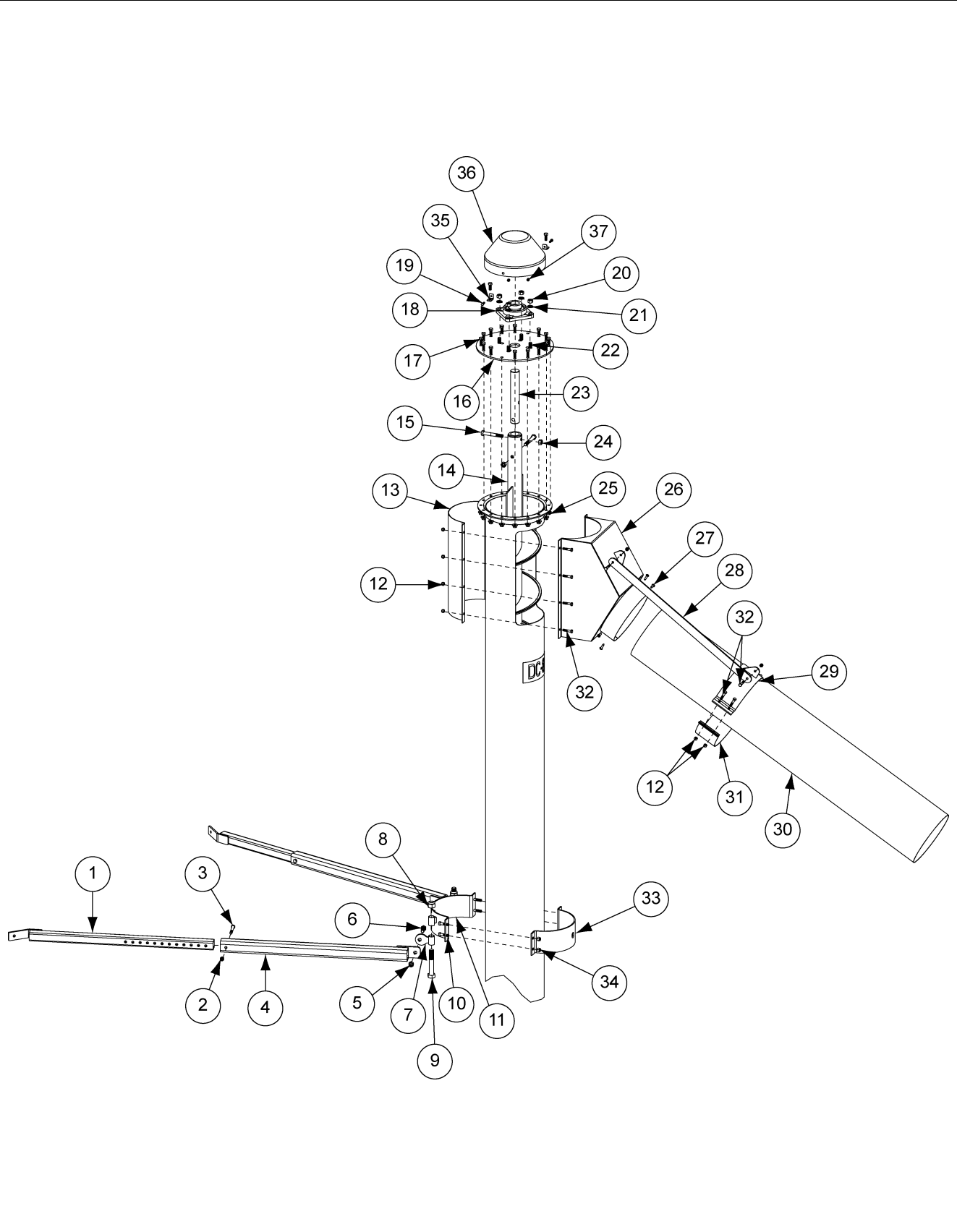

## 10" Top of Vertical Bin Unloader Parts List

Ref #	Part #	Description
1	GK7443	<b>Inner Support Leg</b>
2	S-7383	<b>Leg Adjustment Nut</b> - 3/8"-16 Nylock Lock Nut Zinc Grade 5
3	S-8988	<b>Leg Adjustment Bolt</b> - 3/8"-16 x 2-3/4" HHCS Bolt Zinc Grade 5
4	GK7318	<b>Outer Support Leg</b>
5	S-8260	<b>Leg Attachment Nut</b> - 1/2"-13 Nylock Lock Nut Zinc Grade 5
6	S-7534	<b>Leg Attachment Bolt</b> - 1/2"-13 x 1-1/4" HHCS Bolt Zinc Grade 2
7	GK7536	<b>Leg Support Bracket</b>
8	S-7217	3/4"-10 Nylock Lock Nut Zinc Grade 5
9	S-8063	3/4"-10 x 4-1/2" HHCS Zinc Grade 5
10	S-7515	<b>Half Band Attachment Bolt</b> - 3/8"-16 x 1-1/2" Hex Bolt Stainless Steel
11	GK7868	<b>Mounting Bracket Pivot Band</b>
12	S-7382	5/16"-18 Nylock Nut Zinc Grade 5
13	GK2333	<b>Connecting Band</b>
14	GK1876-2	<b>Vertical Flight</b>
15	S-8314	<b>Flight Bolt</b> - 1/2"-13 x 3-1/2" HHCS YDP Grade 8
16	GK7347	<b>Vertical Bearing Plate</b>
17	S-7469	<b>Bearing Plate Bolt</b> - 3/8"-16 x 1" HHCS Zinc Grade 5
18	GK1343	<b>Bearing</b>
19	S-1429	<b>Cap Bracket Bolt</b> - 1/4"-20 x 3/4" Zinc Grade 2
20	S-3729	<b>Bearing Nut</b> - 1/2"-13 Hex Nut YDP Grade 5
21	S-236	<b>Bearing Lock Washer</b> - 1/2" Lock Washer Zinc
22	S-8760	<b>Bearing Bolt</b> - 1/2"-13 x 1-1/2" HHCS Zinc Grade 5
23	GK2907	<b>Stub Shaft</b>
24	S-8315	<b>Flight Nut</b> - 1/2"-13 Zinc Grade C
25	S-968	<b>Bearing Plate Nut</b> - 3/8"-16 Zinc Grade 5
26	GK7872	<b>60° Spout Weldment</b>
27	S-7229	<b>Spout Screw</b> - 1/4" x 1" Self-drilling Screw Hex Washer Head Zinc
28	GK7805	<b>Spout Support Arm</b>
29	GK7840	<b>Spout Support Band</b>
30	GC08183	<b>Spout Tube</b>
31	GK1301	<b>Half Band</b>
32	S-2741	5/16"-18 x 1-1/2" HHCS Bolt Grade 5
33	GK5117	<b>Half Band</b>
34	S-7383	<b>Half Band Nut</b> - 3/8"-16 Nylock Lock Nut Zinc Grade 5
35	GC12223	<b>Vertical Cap Bracket</b>
36	GC01380	<b>10" Vertical Cap</b>
37	S-7025	<b>Cap Bracket Nut</b> - 1/4"-20 Nylock Nut Zinc Grade 5

# 12" Top of Vertical Bin Unloader Parts

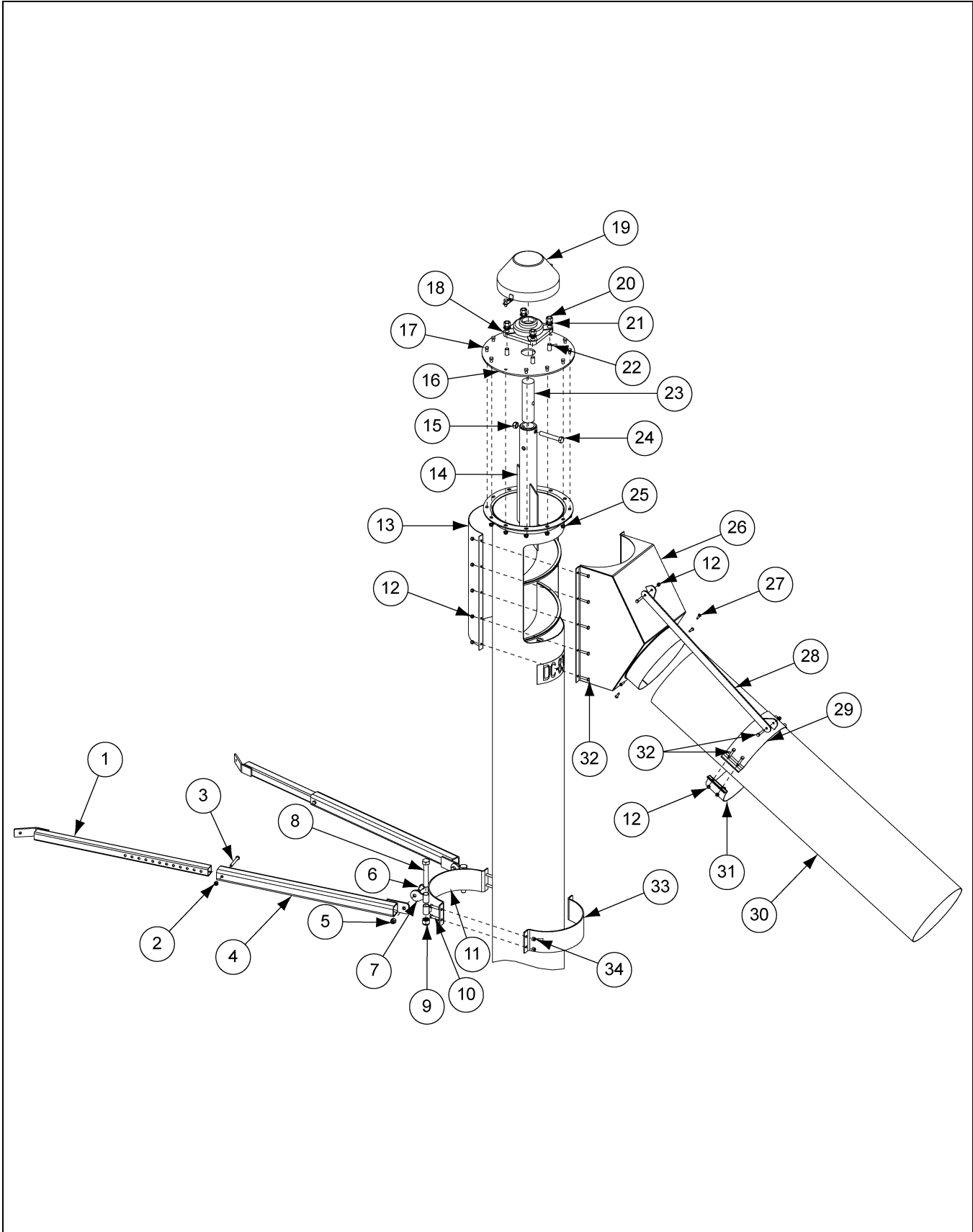

## 12" Top of Vertical Bin Unloader Parts List

Ref #	Part #	Description
1	GK7443	Inner Support Leg
2	S-7383	<b>Leg Adjustment Nut</b> - 3/8"-16 Nylock Lock Nut Zinc Grade 5
3	S-8988	<b>Leg Adjustment Bolt</b> - 3/8"-16 x 2-3/4" HHCS Bolt Zinc Grade 5
4	GK7318	Outer Support Leg
5	S-8260	<b>Leg Attachment Nut</b> - 1/2"-13 Nylock Lock Nut Zinc Grade 5
6	S-7534	<b>Leg Attachment Bolt</b> - 1/2"-13 x 1-1/4" HHCS Bolt Zinc Grade 2
7	GK7536	Leg Support Bracket
8	S-8063	3/4"-10 x 4-1/2" HHCS Zinc Grade 5
9	S-7217	3/4"-10 Nylock Lock Nut Zinc Grade 5
10	S-7515	<b>Half Band Attachment Bolt</b> - 3/8"-16 x 1-1/2" Hex Bolt Stainless Steel
11	GK7535	<b>Mounting Bracket Pivot Band</b>
12	S-7382	5/16"-18 Nylock Nut Grade 5 Zinc
13	GK2415	Connecting Band
14	GK7270-2	Vertical Flight
15	S-8606	<b>Flight Nut</b> - 5/8"-11 Stover Nut Zinc Grade C
16	GK7272	Vertical Bearing Plate
17	S-7469	<b>Bearing Plate Bolt</b> - 3/8"-16 x 1" HHCS Bolt Zinc Grade 5
18	GK2004	Bearing
19	GK7434	Vertical Bearing Cap
20	S-4110	<b>Bearing Nut</b> - 5/8"-11 Hex Nut Zinc Grade 5
21	S-3208	<b>Bearing Lock Washer</b> - 5/8" Lock Split Washer Zinc
22	S-8399	<b>Bearing Bolt</b> - 5/8"-11 x 2" HHCS Bolt Zinc Grade 5
23	GK5313	Stub Shaft
24	S-7893	<b>Flight Bolt</b> - 5/8"-11 x 4" HHCS Bolt Zinc Grade 8
25	S-968	<b>Bearing Plate Nut</b> - 3/8"-16 Serrated Flange Nut Zinc
26	GK7804	60° Spout Weldment
27	S-7229	<b>Spout Screw</b> - 1/4" x 1" Self-drilling Screw Hex Washer Head Zinc
28	GK7805	Spout Support Arm
29	GK7806	Spout Support Band
30	GC08811	Spout Tube
31	GK2014	Half Band
32	S-2741	5/16"-18 x 1-1/2" HHCS Bolt Grade 5
33	GK4599	Half Band
34	S-7383	<b>Half Band Nut</b> - 3/8"-16 Nylock Lock Nut Zinc Grade 5

# 8" Horizontal Drive Parts

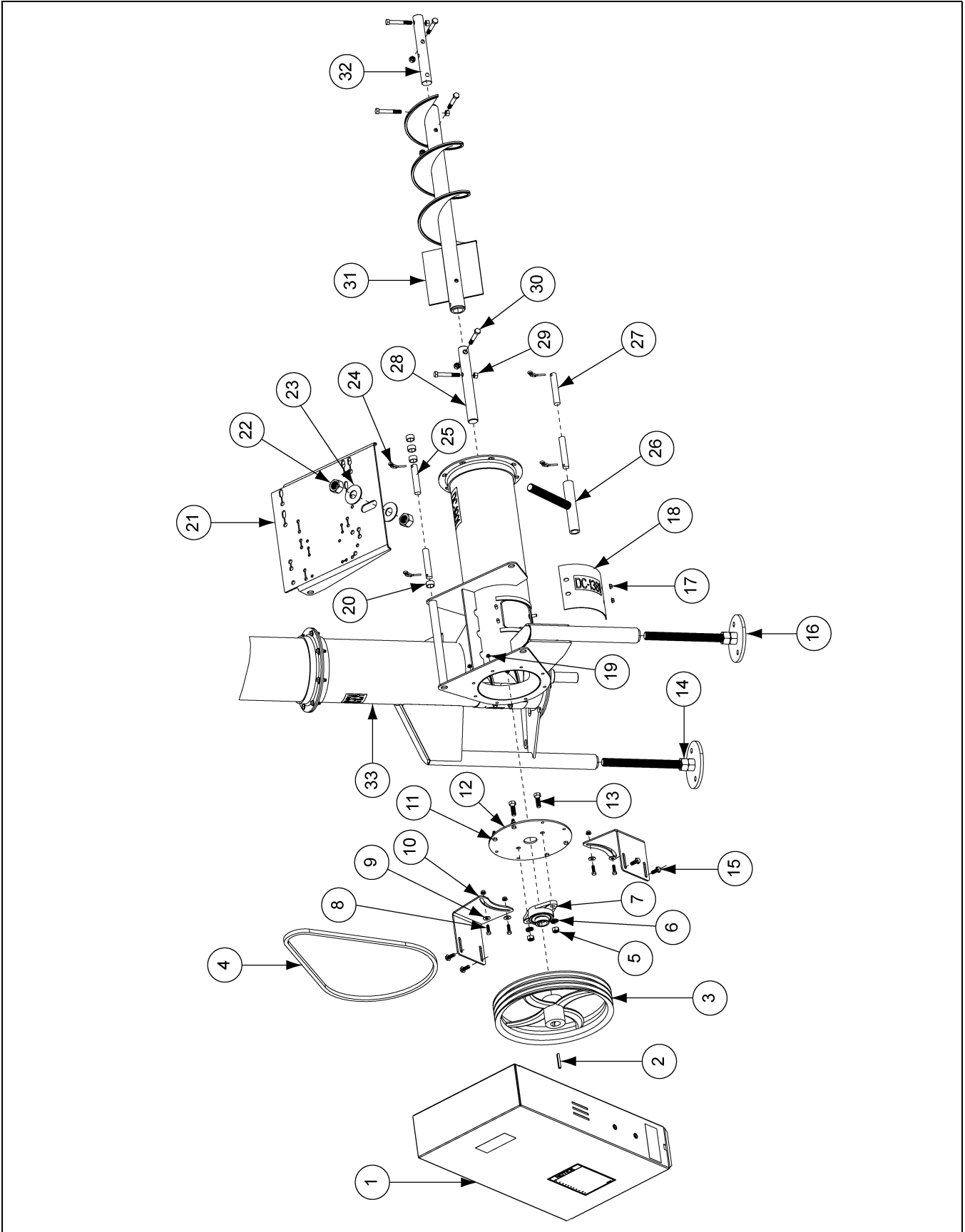

## 8" Horizontal Drive Parts List

Ref #	Part #	Description
1	GK7005	<b>Belt Guard</b> - For Use with 15" Sheaves
2	S-4513	<b>Key</b> - 1/4" x 1/4" x 2"
3	GK1869	<b>Sheave</b> 15"-2B x 1-1/4" I.D.
3	GK2234	<b>Sheave</b> 15"-3B x 1-1/4" I.D.
4	CE-00566	<b>V-Belt</b> B56 (2B)
4	GK1346	<b>V-Belt</b> B57 (3B)
5	S-7510	<b>Bearing Nut</b> - 1/2"-13 Hex Nut Zinc Grade 2
6	S-236	<b>Bearing Lock Washer</b> - 1/2" Lock Washer Zinc
7	GK1330	<b>Bearing</b>
8	S-1196	<b>Belt Guard Bracket Bolt</b> - 5/16"-18 x 1" HHCS Zinc Grade 5
9	S-845	<b>Belt Guard Bracket Washer</b> - 5/16" Flat Washer YDP Grade 2
10	GK7006	<b>Belt Guard Bracket</b>
11	S-1196	<b>Bearing Plate Bolt</b> - 5/16"-18 x 1" HHCS Zinc Grade 5
12	GK6987	<b>Bearing Plate</b>
13	S-8760	<b>Bearing Bolt</b> - 1/2"-13 x 1-1/2" HHCS Zinc Grade 5
14	S-240	1"-8 Hex Nut Zinc Grade 5
15	S-9065	3/8"-16 x 1" Flange Bolt Zinc Grade 5
16	GK7442	<b>Vertical Auger Foot</b>
17	S-3611	5/16"-18 Serrated Flange YDP Grade 2
18	GC11308	<b>Inspection Cover</b>
19	S-3611	<b>Bearing Plate Nut</b> - 5/16"-18 Serrated Flange YDP Grade 2
20	GK7014	<b>Pivot Spacer Tube</b>
21	GK6986	<b>Motor Mount Plate</b>
22	S-240	1"-8 Hex Nut Zinc Grade 5
23	S-7835	1" Flat Washer Zinc
24	S-6994	3/16" x 2" Cotter Pin Zinc Grade 2
25	GK7013	<b>Motor Mount Pivot Rod</b>
26	GK6942	<b>Motor Mount Adjustment Weldment</b>
27	GK7012	<b>Motor Mount Adjustment Pivot Rod</b>
28	GK1331	<b>Drive Shaft</b> - 1-1/4" x 10-1/2"
29	S-8317	<b>Flight Nut</b> - 7/16"-14 Stover Nut Zinc Grade C
30	S-8316	<b>Flight Bolt</b> - 7/16"-14 x 3" HHCS Zinc YDP Grade 8
31	GK7425	<b>Horizontal Flight</b>
32	GK1328	<b>Connecting Shaft</b> - 1-1/4" x 9-1/2"
33	GK7393	<b>Cross-Tube</b>

# 10" Horizontal Drive Parts

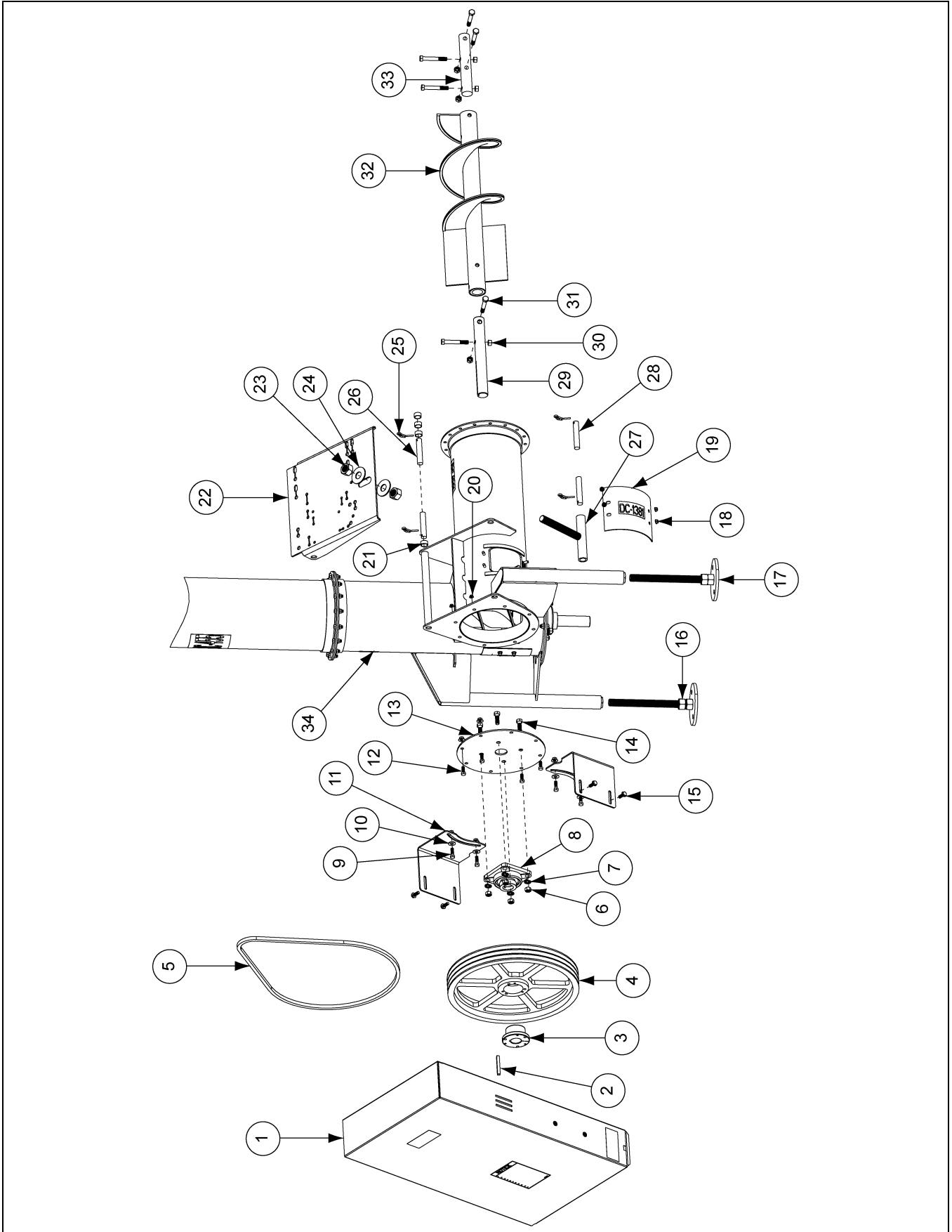



## 10" Horizontal Drive Parts List

Ref #	Part #	Description
1	GK7068	<b>Belt Guard</b> - For Use with 18.4" Sheaves
2	S-4513	<b>Key</b> - 1/4" x 1/4" x 2"
3	GK4248	<b>SK Sheave Bushing 1-1/2" I.D.</b>
4	GK2567	<b>Sheave</b> 18.4"-2B x SK
4	GK2570	<b>Sheave</b> 18.4"-3B x SK
5	MHC00743	<b>V-Belt</b> BX65 (2B)
5	MHC00485	<b>V-Belt</b> BX67 (3B)
6	S-7510	<b>Bearing Nut</b> - 1/2"-13 Hex Nut Zinc Grade 2
7	S-236	<b>Bearing Lock Washer</b> - 1/2" Lock Washer Zinc
8	GK1343	<b>Bearing</b>
9	S-2071	<b>Belt Guard Bracket Bolt</b> - 3/8"-16 x 1-1/4" HHCS Zinc Grade 5
10	S-248	<b>Belt Guard Bracket Washer</b> - 3/8" Flat Washer YDP
11	GK7101	<b>Belt Guard Bracket</b>
12	S-7469	<b>Bearing Plate Bolt</b> - 3/8"-16 x 1" HHCS Zinc Grade 5
13	GK7017	<b>Bearing Plate</b>
14	S-8760	<b>Bearing Bolt</b> - 1/2"-13 x 1-1/2" HHCS Zinc Grade 5
15	S-9065	3/8"-16 x 1" Flange Bolt Zinc Grade 5
16	S-240	1"-8 Hex Nut Zinc Grade 5
17	GK7442	<b>Vertical Auger Foot</b>
18	S-3611	5/16"-18 Serrated Flange YDP Grade 2
19	GC11242	<b>Inspection Cover</b>
20	S-968	<b>Bearing Plate Nut</b> - 3/8"-16 Serrated Flange Nut Zinc Grade 5
21	GK7014	<b>Pivot Spacer Tube</b>
22	GK6986	<b>Motor Mount Plate</b>
23	S-240	1"-8 Hex Nut Zinc Grade 5
24	S-7835	1" Flat Washer Zinc
25	S-6994	3/16" x 2" Cotter Pin Zinc Grade 2
26	GK7013	<b>Motor Mount Pivot Rod</b>
27	GK6942	<b>Motor Mount Adjustment Weldment</b>
28	GK7012	<b>Motor Mount Adjustment Pivot Rod</b>
29	GK1289	<b>Drive Shaft</b> - 1-1/2" x 12-1/2"
30	S-8315	<b>Flight Nut</b> - 1/2"-13 Stover Nut Zinc Grade C
31	S-8314	<b>Flight Bolt</b> - 1/2"-13 x 3-1/2" HHCS YDP Grade 8
32	GK2563	<b>Horizontal Flight</b>
33	GK1339	<b>Connecting Shaft</b> - 1-1/2" x 9-1/2"
34	GK7344	<b>Cross-Tube</b>

# 12" Horizontal Drive Parts

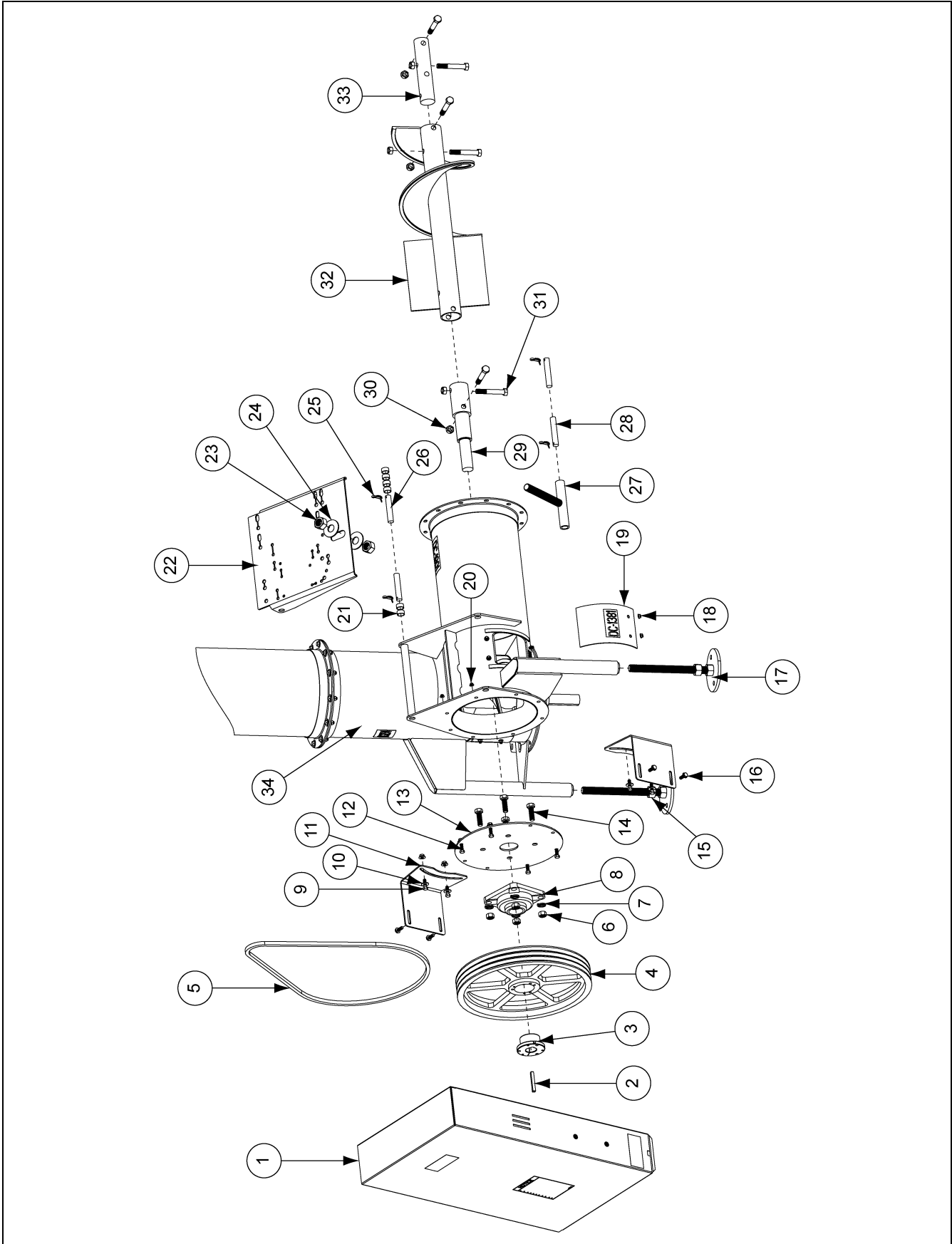

## 12" Horizontal Drive Parts List

Ref #	Part #	Description
1	GK7068	<b>Belt Guard</b> - For use with 18.4" Sheaves
2	S-9181	<b>Key</b> - 3/8" x 3/8" x 3" Keyway
3	GK4248	1-1/2" Bore Sheave Bushing SK
4	GK2567	Sheave 18.4"-2B x SK
4	GK2570	Sheave 18.4"-3B x SK
5	MHC00020	V-Belt BX68 (2B)
5	MHC00486	V-Belt BX70 (3B)
6	S-4110	<b>Bearing Nut</b> - 5/8"-11 Hex Nut Zinc Grade 5
7	S-3208	<b>Bearing Lock Washer</b> - 5/8" Lock Split Washer Zinc
8	GK2004	<b>Bearing</b>
9	S-2071	<b>Belt Guard Bracket Bolt</b> - 3/8"-16 x 1-1/4" HHCS Bolt Zinc Grade 5
10	S-248	<b>Belt Guard Bracket Washer</b> - 3/8" Flat Washer
11	GK7065	<b>Belt Guard Bracket</b>
12	S-7469	<b>Bearing Plate Bolt</b> - 3/8"-16 x 1" HHCS Bolt Zinc Grade 5
13	GK7064	<b>Bearing Plate</b>
14	S-8399	<b>Bearing Bolt</b> - 5/8"-11 x 2" HHCS Bolt Zinc Grade 5
15	S-240	1"-8 Hex Nut Grade 5
16	S-9065	3/8"-16 x 1" Flange Bolt Zinc Grade 5
17	GK7442	<b>Vertical Auger Foot</b>
18	S-3611	5/16"-18 Serrated Flange Nut Zinc
19	GC11041	<b>Inspection Cover</b>
20	S-968	<b>Bearing Plate Nut</b> - 3/8"-16 Serrated Flange Nut Zinc
21	GK7014	<b>Pivot Spacer Tube</b>
22	GK6986	<b>Motor Mount Plate</b>
23	S-240	1"-8 Hex Nut Grade 5
24	S-7835	2-1/2" O.D. x 1" I.D. Flat Washer
25	S-6994	3/16" x 2" Cotter Pin Grade 2
26	GK7013	<b>Motor Mount Pivot Rod</b>
27	GK6942	<b>Motor Mount Adjustment Weldment</b>
28	GK7012	<b>Motor Mount Adjustment Pivot Rod</b>
29	GK2006	<b>Drive Shaft</b> - 2" x 12"
30	S-8606	<b>Flight Nut</b> - 5/8"-11 Stover Nut Zinc Grade C
31	S-7893	<b>Flight Bolt</b> - 5/8"-11 x 4" HHCS Bolt Zinc Grade 8
32	GK7269	Horizontal Flight
33	GK2319	<b>Connecting Shaft</b> - 2" x 9-1/2"
34	GK7215	Cross-Tube

# 8" Vertical Drive Parts

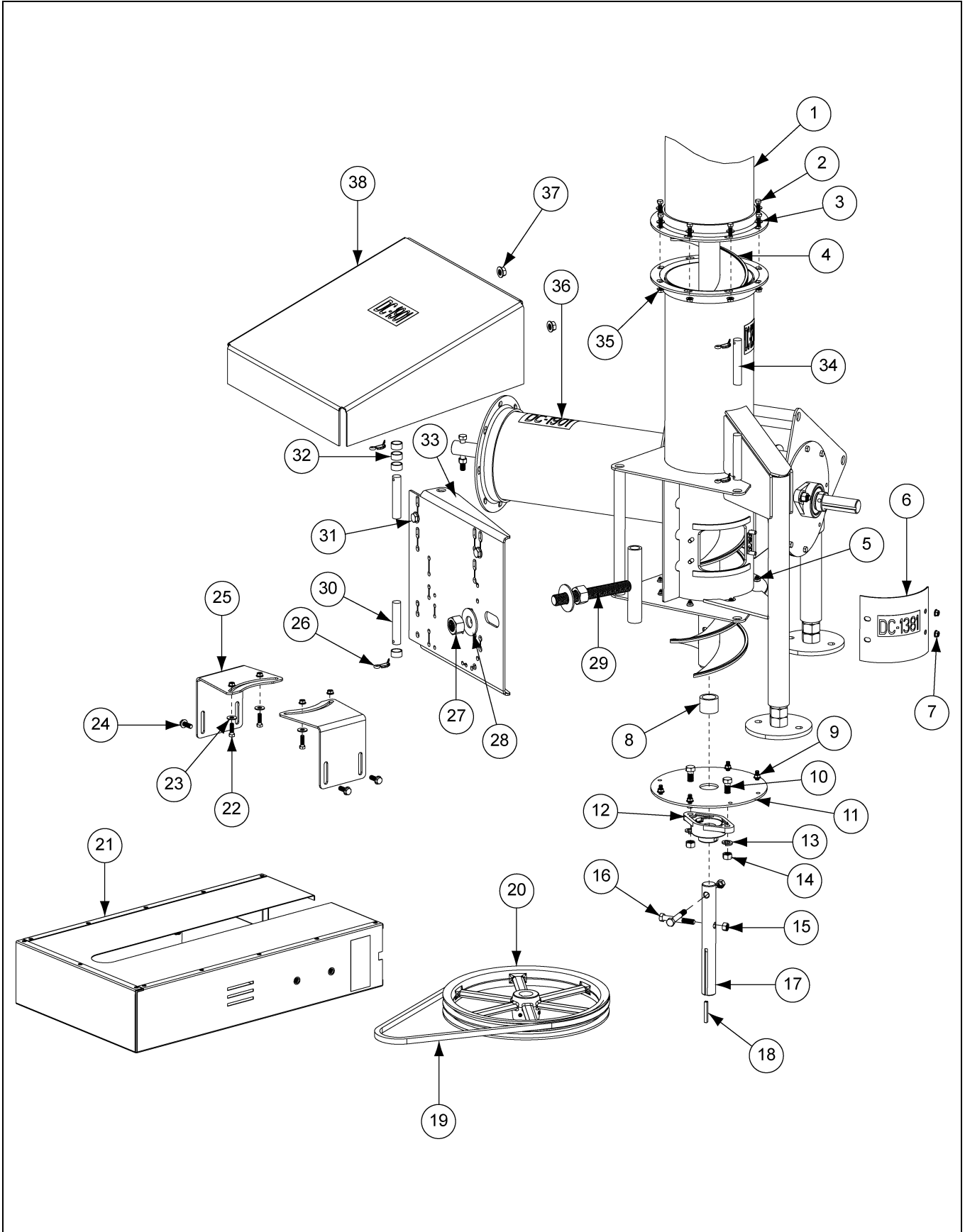

## 8" Vertical Drive Parts List

Ref #	Part #	Description
1	GK7395-2	Vertical Tube
2	S-1196	Tube Connecting Bolt - 5/16"-18 x 1" HHCS Zinc Grade 5
3	S-1937	Tube Connecting Washer - 5/16" Flat Washer Zinc Grade 2
4	GK7426-2	Vertical Flight
5	S-3611	Bearing Plate Nut - 5/16"-18 Serrated Flange Nut YDP Grade 2
6	GC11308	Inspection Cover
7	S-3611	5/16"-18 Serrated Flange Nut YDP Grade 2
8	GC11360	Vertical Flight Spacer
9	S-1196	Bearing Plate Bolt - 5/16"-18 x 1" HHCS Zinc Grade 5
10	S-8760	Bearing Bolt - 1/2"-13 x 1-1/2" HHCS Zinc Grade 5
11	GK6987	Bearing Plate
12	GK1330	Bearing
13	S-236	Bearing Lock Washer - 1/2" Lock Washer Zinc
14	S-7510	Bearing Nut - 1/2"-13 Hex Nut Grade 2
15	S-8317	Flight Nut - 7/16"-14 Stover Nut Zinc Grade C
16	S-8316	Flight Bolt - 7/16"-14 x 3" HHCS Zinc YDP Grade 8
17	GK1331	Drive Shaft - 1-1/4" x 10-1/2"
18	S-4513	Key - 1/4" x 1/4" x 2"
19	GK1346	V-Belt B57 (2B)
20	GK1869	Sheave 15"-2B x 1-1/4" I.D.
21	GK7005	Belt Guard - For Use with 15" Sheaves
22	S-1196	Belt Guard Bracket Bolt - 5/16"-18 x 1" HHCS Zinc Grade 5
23	S-845	Belt Guard Bracket Washer - 5/16" Flat Washer YDP Grade 2
24	S-9065	3/8"-16 x 1" Flange Bolt Zinc Grade 5
25	GK7006	Belt Guard Bracket
26	S-6994	3/16" x 2" Cotter Pin Zinc Grade 2
27	S-240	1"-8 Hex Nut Zinc Grade 5
28	S-7835	1" Flat Washer Zinc
29	GK6942	Motor Mount Adjustment Weldment
30	GK7013	Motor Mount Pivot Rod
31	S-9062	Cover Connecting Bolt - 1/2"-13 x 1-1/4" Flange Bolt Zinc Grade 5
32	GK7014	Pivot Spacer Tube
33	GK6986	Motor Mount Plate
34	GK7012	Motor Mount Adjustment Pivot Rod
35	S-3611	Tube Connecting Nut - 5/16"-18 Serrated Flange Nut YDP Grade 2
36	GK7393	Cross-Tube
37	S-8506	Cover Connecting Nut - 1/2"-13 Serrated Flange Nut Zinc
38	GC12008	Vertical Motor Cover

10" Vertical Drive Parts

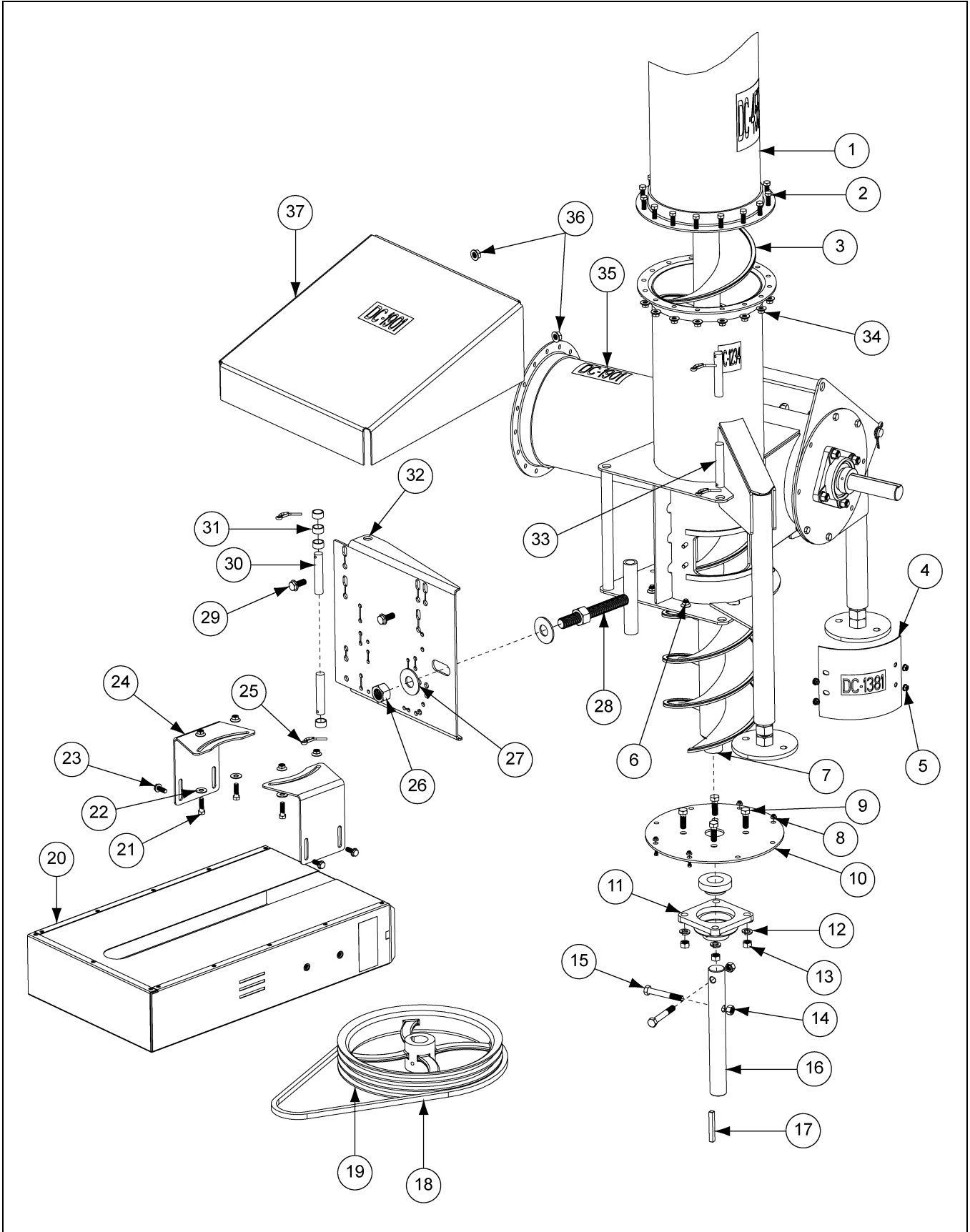

## 10" Vertical Drive Parts List

Ref #	Part #	Description
1	GK7345-2	Vertical Tube
2	S-7469	Tube Connecting Bolt - 3/8"-16 x 1" HHCS Zinc Grade 5
3	GK1876-2	Vertical Flight
4	GC11242	Inspection Cover
5	S-3611	5/16"-18 Serrated Flange YDP Grade 2
6	S-968	Bearing Plate Nut - 3/8"-16 Serrated Flange Nut Zinc Grade 5
7	GC11250	Vertical Flight Spacer
8	S-7469	Bearing Plate Bolt - 3/8"-16 x 1" HHCS Zinc Grade 5
9	S-8760	Bearing Bolt - 1/2"-13 x 1-1/2" HHCS Zinc Grade 5
10	GK7017	Bearing Plate
11	GK1343	Bearing
12	S-236	Bearing Lock Washer - 1/2" Lock Washer Zinc
13	S-7510	Bearing Nut - 1/2"-13 Hex Nut Zinc Grade 2
14	S-8315	Flight Nut - 1/2"-13 Stover Nut Zinc Grade C
15	S-8314	Flight Bolt - 1/2"-13 x 3-1/2" HHCS YDP Grade 8
16	GK1289	Drive Shaft - 1-1/2" x 12-1/2"
17	S-9181	Key - 3/8" x 3/8" x 3"
18	GK4441	V-Belt B60 (3B)
19	GK1304	Sheave 15"-3B x 1-1/2" I.D.
20	GK7005	Belt Guard - For Use with 15" Sheaves
21	S-2071	Belt Guard Bracket Bolt - 3/8"-16 x 1-1/4" HHCS Zinc Grade 5
22	S-248	Belt Guard Bracket Washer - 3/8" Flat Washer YDP
23	S-9065	3/8"-16 1" Flange Bolt Zinc Grade 5
24	GK7018	Belt Guard Bracket
25	S-6994	3/16" x 2" Cotter Pin Zinc Grade 2
26	S-240	1"-8 Hex Nut Zinc Grade 5
27	S-7835	Motor Mount Pivot Rod
28	GK6942	Motor Mount Adjustment Weldment
29	S-9062	Cover Connecting Bolt - 1/2"-13 x 1-1/4" HHCS Zinc Grade 5
30	GK7013	Motor Mount Pivot Rod
31	GK7014	Pivot Spacer Tube
32	GK6986	Motor Mount Plate
33	GK7012	Motor Mount Adjustment Pivot Rod
34	S-968	Tube Connecting Nut - 3/8"-16 Serrated Flange Nut Zinc Grade 5
35	GK7344	Cross-Tube
36	S-8506	Cover Connecting Nut - 1/2"-13 Serrated Flange Nut Zinc
37	GC12008	Vertical Motor Cover

# 12" Vertical Drive Parts

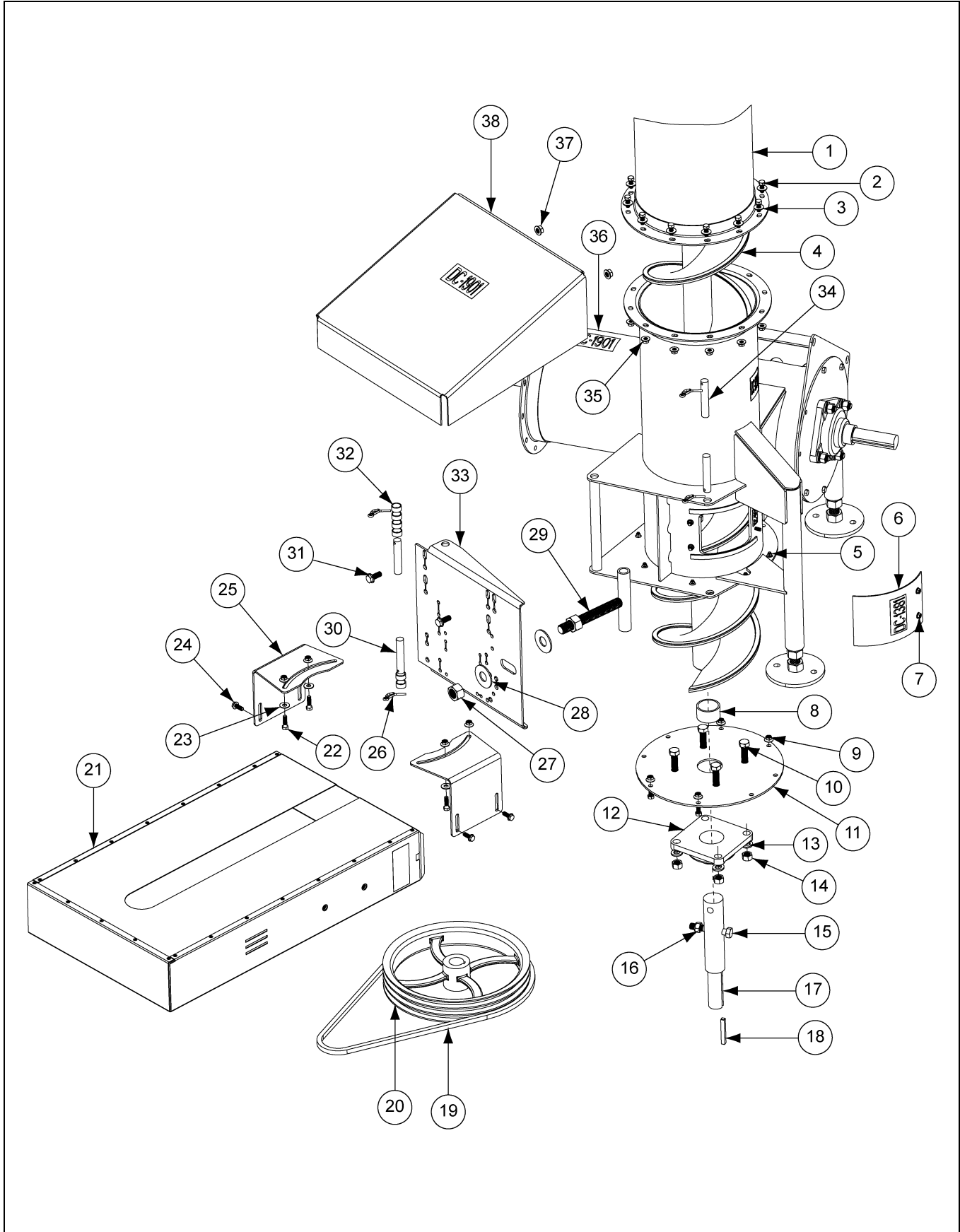



## 12" Vertical Drive Parts List

Ref #	Part #	Description
1	GK7271-2	<b>Vertical Tube</b>
2	S-7469	<b>Tube Connecting Bolt - 3/8"-16 x 1" HHCS Bolt Zinc Grade 5</b>
3	S-248	<b>Tube Connecting Washer - 3/8" Flat Washer Zinc Grade 2</b>
4	GK7270-2	<b>Vertical Flight</b>
5	S-968	<b>Bearing Plate Nut - 3/8"-16 Serrated Flange Nut Zinc</b>
6	GC11041	<b>Inspection Cover</b>
7	S-3611	5/16"-18 Serrated Flange Nut Zinc
8	GC11080	<b>Vertical Flight Spacer</b>
9	S-7469	<b>Bearing Plate Bolt - 3/8"-16 x 1" HHCS Bolt Zinc Grade 5</b>
10	S-8399	<b>Bearing Bolt - 5/8"-11 x 2" HHCS Bolt Zinc Grade 5</b>
11	GK7064	<b>Bearing Plate</b>
12	GK2004	<b>Bearing</b>
13	S-3208	<b>Bearing Lock Washer - 5/8" Lock Split Washer Zinc</b>
14	S-4110	<b>Bearing Nut - 5/8"-11 Hex Nut Zinc Grade 5</b>
15	S-7893	<b>Flight Bolt - 5/8"-11 x 4" HHCS Bolt Zinc Grade 8</b>
16	S-8606	<b>Flight Nut - 5/8"-11 Stover Nut Zinc Grade C</b>
17	GK2006	<b>Drive Shaft - 2" x 12"</b>
18	S-9181	<b>Key - 3/8" x 3/8" x 3" Keyway</b>
19	MHC01253	<b>V-Belt BX62</b>
20	GK1304	<b>Sheave - Sheave 3GR B 15" x 1-1/2" Aluminium</b>
21	GK7068	<b>Belt Guard - For Use with 18.4" Sheaves</b>
22	S-2071	<b>Belt Guard Bracket Bolt - 3/8"-16 x 1-1/4" HHCS Bolt Zinc Grade 5</b>
23	S-248	<b>Belt Guard Bracket Washer - 3/8" Flat Washer Zinc Grade 2</b>
24	S-9065	3/8"-16 x 1" Flange Bolt Zinc Grade 5
25	GK7065	<b>Belt Guard Bracket</b>
26	S-6994	3/16" x 2" Cotter Pin Grade 2
27	S-240	1"-8 Hex Nut Grade 5
28	S-7835	2-1/2" O.D. x 1" I.D. Flat Washer
29	GK6942	<b>Motor Mount Adjustment Weldment</b>
30	GK7013	<b>Motor Mount Pivot Rod</b>
31	S-9062	<b>Cover Connecting Bolt - 1/2"-13 x 1-1/4" Flange Bolt Zinc Grade 5</b>
32	GK7014	<b>Pivot Spacer Tube</b>
33	GK6986	<b>Motor Mount Plate</b>
34	GK7012	<b>Motor Mount Adjustment Pivot Rod</b>
35	S-968	<b>Tube Connecting Nut - 3/8"-16 Serrated Flange Nut Zinc</b>
36	GK7215	<b>Cross-Tube</b>
37	S-8506	<b>Cover Connecting Nut - 1/2"-13 Serrated Flange Nut Zinc</b>
38	GC12008	<b>Vertical Motor Cover</b>

---

# NOTES

## GSI Group, LLC Limited Warranty

The GSI Group, LLC ("GSI") warrants products which it manufactures to be free of defects in materials and workmanship under normal usage and conditions for a period of 12 months after sale to the original end-user or if a foreign sale, 14 months from arrival at port of discharge, whichever is earlier. The end-user's sole remedy (and GSI's only obligation) is to repair or replace, at GSI's option and expense, products that in GSI's judgment, contain a material defect in materials or workmanship. Expenses incurred by or on behalf of the end-user without prior written authorization from the GSI Warranty Group shall be the sole responsibility of the end-user.

### Warranty Extensions:

The Limited Warranty period is extended for the following products:

	Product	Warranty Period	
<b>AP Fans and Flooring</b>	Performer Series Direct Drive Fan Motor	3 Years	* Warranty prorated from list price: 0 to 3 years - no cost to end-user 3 to 5 years - end-user pays 25% 5 to 7 years - end-user pays 50% 7 to 10 years - end-user pays 75%
	All Fiberglass Housings	Lifetime	
	All Fiberglass Propellers	Lifetime	
<b>AP and Cumberland</b>	Flex-Flo/Pan Feeding System Motors	2 Years	** Warranty prorated from list price: 0 to 3 years - no cost to end-user 3 to 5 years - end-user pays 50%
<b>Cumberland Feeding/Watering Systems</b>	Feeder System Pan Assemblies	5 Years **	
	Feed Tubes (1-3/4" and 2.00")	10 Years *	
	Centerless Augers	10 Years *	
	Watering Nipples	10 Years *	
<b>Grain Systems</b>	Grain Bin Structural Design	5 Years	† Motors, burner components and moving parts not included. Portable dryer screens included. Tower dryer screens not included.
<b>Grain Systems Farm Fans Zimmerman</b>	Portable and Tower Dryers	2 Years	
	Portable and Tower Dryer Frames and Internal Infrastructure †	5 Years	

GSI further warrants that the portable and tower dryer frame and basket, excluding all auger and auger drive components, shall be free from defects in materials for a period of time beginning on the twelfth (12<sup>th</sup>) month from the date of purchase and continuing until the sixtieth (60<sup>th</sup>) month from the date of purchase (extended warranty period). During the extended warranty period, GSI will replace the frame or basket components that prove to be defective under normal conditions of use without charge, excluding the labor, transportation, and/or shipping costs incurred in the performance of this extended warranty.

### Conditions and Limitations:

THERE ARE NO WARRANTIES THAT EXTEND BEYOND THE LIMITED WARRANTY DESCRIPTION SET FORTH ABOVE. SPECIFICALLY, GSI MAKES NO FURTHER WARRANTY OF ANY KIND, EXPRESS OR IMPLIED, INCLUDING, WITHOUT LIMITATION, WARRANTIES OF MERCHANTABILITY OR FITNESS FOR A PARTICULAR PURPOSE OR USE IN CONNECTION WITH: (I) PRODUCT MANUFACTURED OR SOLD BY GSI OR (II) ANY ADVICE, INSTRUCTION, RECOMMENDATION OR SUGGESTION PROVIDED BY AN AGENT, REPRESENTATIVE OR EMPLOYEE OF GSI REGARDING OR RELATED TO THE CONFIGURATION, INSTALLATION, LAYOUT, SUITABILITY FOR A PARTICULAR PURPOSE, OR DESIGN OF SUCH PRODUCTS.

GSI shall not be liable for any direct, indirect, incidental or consequential damages, including, without limitation, loss of anticipated profits or benefits. The sole and exclusive remedy is set forth in the Limited Warranty, which shall not exceed the amount paid for the product purchased. This warranty is not transferable and applies only to the original end-user. GSI shall have no obligation or responsibility for any representations or warranties made by or on behalf of any dealer, agent or distributor.

GSI assumes no responsibility for claims resulting from construction defects or unauthorized modifications to products which it manufactured. Modifications to products not specifically delineated in the manual accompanying the equipment at initial sale will void the Limited Warranty.

This Limited Warranty shall not extend to products or parts which have been damaged by negligent use, misuse, alteration, accident or which have been improperly/inadequately maintained. This Limited Warranty extends solely to products manufactured by GSI.

Prior to installation, the end-user has the responsibility to comply with federal, state and local codes which apply to the location and installation of products manufactured or sold by GSI.

This equipment shall be installed in accordance with the current installation codes and applicable regulations, which should be carefully followed in all cases. Authorities having jurisdiction should be consulted before installations are made.

G S I G R O U P



**GSI Group**  
1004 E. Illinois St.  
Assumption, IL 62510-0020  
Phone: 1-217-226-4421  
Fax: 1-217-226-4420  
[www.gsiag.com](http://www.gsiag.com)



**GSI is a worldwide brand of AGCO Corporation.**