

Sweep Tractor Assembly Instructions

Instruction Manual

PNEG-1597

Date: 10-11-10

GSI GROUP



PNEG-1597

Personnel operating or working around this equipment should read this manual. This manual must be delivered with equipment to its owner. Failure to read this manual and its safety instructions is a misuse of the equipment. Any misuse of the equipment may void the warranty.

Contents

Chapter 1 Introduction	4
General Information	4
Chapter 2 Safety	5
Safety Guidelines	5
Safety Instructions	6
Operator Qualifications	9
Chapter 3 Safety Decals	10
Chapter 4 Assembly	11
Sweep Tractor Assembly	11
End Wheel Assembly	21
Sweep Tractor to Shield Assembly	22
Chapter 5 Parts List	23
Sweep Tractor Parts	24
Chain Guard Assembly	26
Drive Motor Assembly	27
Bearing Stand Assembly	28
Chapter 6 Warranty	29

1. Introduction

General Information

1. We reserve the right to improve our product whenever possible and practical to do so. We reserve the right to change, improve and modify products at any time without obligation to make changes, improvements and modifications on equipment sold previously
2. The Sweep Tractor has been designed and manufactured to give years of dependable service. The care and maintenance of this machine will affect the satisfaction and service obtained. By observing the instructions and suggestions we have recommended, the owner should receive competent service for many years. If additional information or assistance should be required, please contact the factory or your local dealer.

3. Receiving Merchandise and Filing Claims

- a. When receiving merchandise, it is important to check both the quantity of parts and their descriptions with the packing list enclosed within each package. All claims for freight damage or shortage must be made by the consignee within ten (10) days from the date of the occurrence of freight damage. The consignee should accept the shipment after noting the damage or loss.

For Claims Contact:

**GSI Group
1004 E. Illinois St.
Assumption, IL. 62510
Phone: 1-217-226-4421**

Safety Guidelines

This manual contains information that is important for you, the owner/operator, to know and understand. This information relates to protecting **personal safety** and **preventing equipment problems**. It is the responsibility of the owner/operator to inform anyone operating or working in the area of this equipment of these safety guidelines. To help you recognize this information, we use the symbols that are defined below. Please read the manual and pay attention to these sections. Failure to read this manual and its safety instructions is a misuse of the equipment and may lead to serious injury or death.



This is the safety alert symbol. It is used to alert you to potential personal injury hazards. Obey all safety messages that follow this symbol to avoid possible injury or death.



DANGER indicates an imminently hazardous situation which, if not avoided, will result in death or serious injury.



WARNING indicates a potentially hazardous situation which, if not avoided, could result in death or serious injury.



CAUTION indicates a potentially hazardous situation which, if not avoided, may result in minor or moderate injury.



CAUTION used without the safety alert symbol indicates a potentially hazardous situation which, if not avoided, may result in property damage.



NOTE indicates information about the equipment that you should pay special attention.

2. Safety

Safety Instructions

Our foremost concern is your safety and the safety of others associated with this equipment. We want to keep you as a customer. This manual is to help you understand safe operating procedures and some problems which may be encountered by the operator and other personnel.

As owner and/or operator, it is your responsibility to know what requirements, hazards and precautions exist, and to inform all personnel associated with the equipment or in the area. Safety precautions may be required from the personnel. Avoid any alterations to the equipment. Such alterations may produce a very dangerous situation where **SERIOUS INJURY** or **DEATH** may occur.

This equipment shall be installed in accordance with the current installation codes and applicable regulations which should be carefully followed in all cases. Authorities having jurisdiction should be consulted before installations are made.

Follow Safety Instructions

Carefully read all safety messages in this manual and safety signs on your machine. Keep signs in good condition. Replace missing or damaged safety signs. Be sure new equipment components and repair parts include the current safety signs. Replacement safety signs are available from the manufacturer.

Learn how to operate the machine and how to use controls properly. Do not let anyone operate without instruction.

Keep your machinery in proper working condition. Unauthorized modifications to the machine may impair the function and/or safety and affect machine life.

If you do not understand any part of this manual or need assistance, contact your dealer.

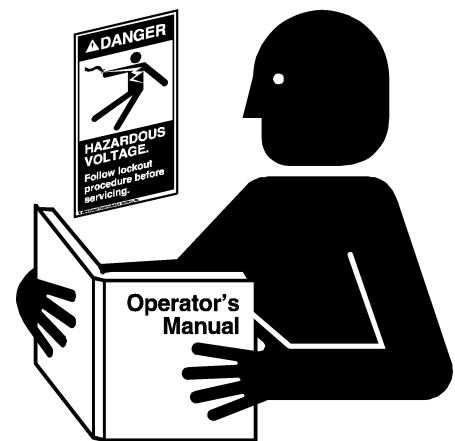

Read and Understand Manual

Practice Safe Maintenance

Understand service procedures before doing work. Keep area clean and dry.

Never lubricate, service, or adjust machine while it is in operation. Keep hands, feet and clothing away from rotating parts.

Keep all parts in good condition and properly installed. Fix damage immediately. Replace worn or broken parts. Remove any built up grease oil and debris.



Maintain Equipment and Work Area

Prepare for Emergencies

Be prepared if fire starts.

Keep a first aid kit and fire extinguisher handy.

Keep emergency numbers for doctors, ambulance service, hospital and fire department near your telephone.

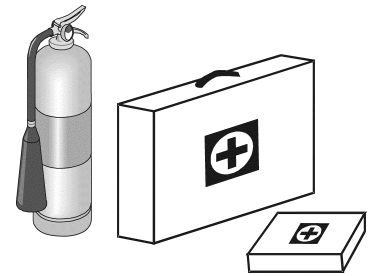

Keep Emergency Equipment Quickly Accessible

Wear Protective Clothing

Wear close fitting clothing and safety equipment appropriate to the job.

Remove all jewelry.

Long hair should be tied up and back.

Safety glasses should be worn at all times to protect eyes from debris.

Wear gloves to protect your hands from sharp edges on plastic or steel parts.

Wear steel toe boots to help protect your feet from falling debris. Tuck in any loose or dangling shoe strings.

A respirator may be needed to prevent breathing potentially toxic fumes and dust.

Wear hard hat to help protect your head.

Wear appropriate fall protection equipment when working at elevations greater than six feet (6').

Eye Protection

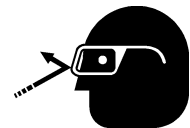

Gloves



Steel Toe Boots



Respirator



Hard Hat



Fall Protection



Operate Unload Equipment Properly

- Untrained operators subject themselves and others to **SERIOUS INJURY** or **DEATH**. **NEVER** allow untrained personnel to operate this equipment.
- **NEVER** work alone.
- Keep children and other unqualified personnel out of the working area at **ALL** times. Refer to the **Start-Up** section of this manual for diagrams of the work area.
- Make sure **ALL** equipment is locked in position before operating.
- **NEVER** start equipment until **ALL** persons are clear of the work area.
- Keep hands and feet away from the auger intake and other moving parts.
- **NEVER** attempt to assist machinery operation or to remove trash from equipment while in operation.
- Be sure all operators are adequately rested and prepared to perform all functions of operating this equipment.
- **NEVER** allow any person intoxicated or under the influence of alcohol or drugs to operate the equipment.
- Make sure someone is nearby who is aware of the proper shut down sequence in the event of an accident or emergency.
- **ALWAYS** think before acting. **NEVER** act impulsively around the equipment.
- **NEVER** allow anyone inside a bin, truck or wagon which is being unloaded by an auger or conveyor. Flowing grain can trap and suffocate in seconds.
- Use ample overhead lighting after sunset to light the work area.
- Keep area around intake free of obstacles such as electrical cords, blocks, etc., that might trip workers.
- **NEVER** drive, stand or walk under the equipment.
- Use caution not to hit the auger when positioning the load.
- **ALWAYS** lock out **ALL** power to the equipment when finished unloading a bin.
- Be aware of pinch points. A pinch point is a narrow area between two surfaces that is likely to trap or catch objects and so is a potential safety hazard.



**Operate Unload
Equipment Safely**

Operator Qualifications

- A. The User/Operator must be competent and experienced to operate auger equipment. Anyone who works with or around augers must have good common sense in order to be qualified. These persons must also know and meet all other qualifications, such as:
 - i. Any person who has not read and/or does not understand all operation and safety procedures is not qualified to operate any auger systems.
 - ii. Certain regulations apply to personnel operating power machinery. Personnel under the age of 18 years may not operate power machinery, including augers. It is your responsibility, as owner and/or supervisor, to know what these regulations are in your area or situation.
 - iii. Unqualified or incompetent persons are to remain out of the work area.
 - iv. O.S.H.A. (Occupational Safety and Health Administration) regulations state: “At the time of initial assignment and at least annually thereafter, the employer shall instruct every employee in the safe operation and servicing of all equipment with which the employee is, or will be involved”. (Federal Occupational Safety and Health Standards for Agriculture. Subpart D, Section 1928.57 (a) (6)).

- B. As a requirement of O.S.H.A., it is necessary for the employer to train the employee in the safe operating and safety procedures for this auger. The sign-off sheet is provided for your convenience and personal record keeping. All unqualified persons are to stay out of the work area at all times. It is strongly recommended that another qualified person who knows the shut down procedure is in the area in the event of an emergency.

Date	Employee Name	Supervisor Name



3. Safety Decals

Check components shown below to ensure that the safety decals are in place and in good condition. If a decal cannot be easily read for any reason or has been painted over, replace it immediately. Contact your dealer or the manufacturer to order a replacement decal free of charge.

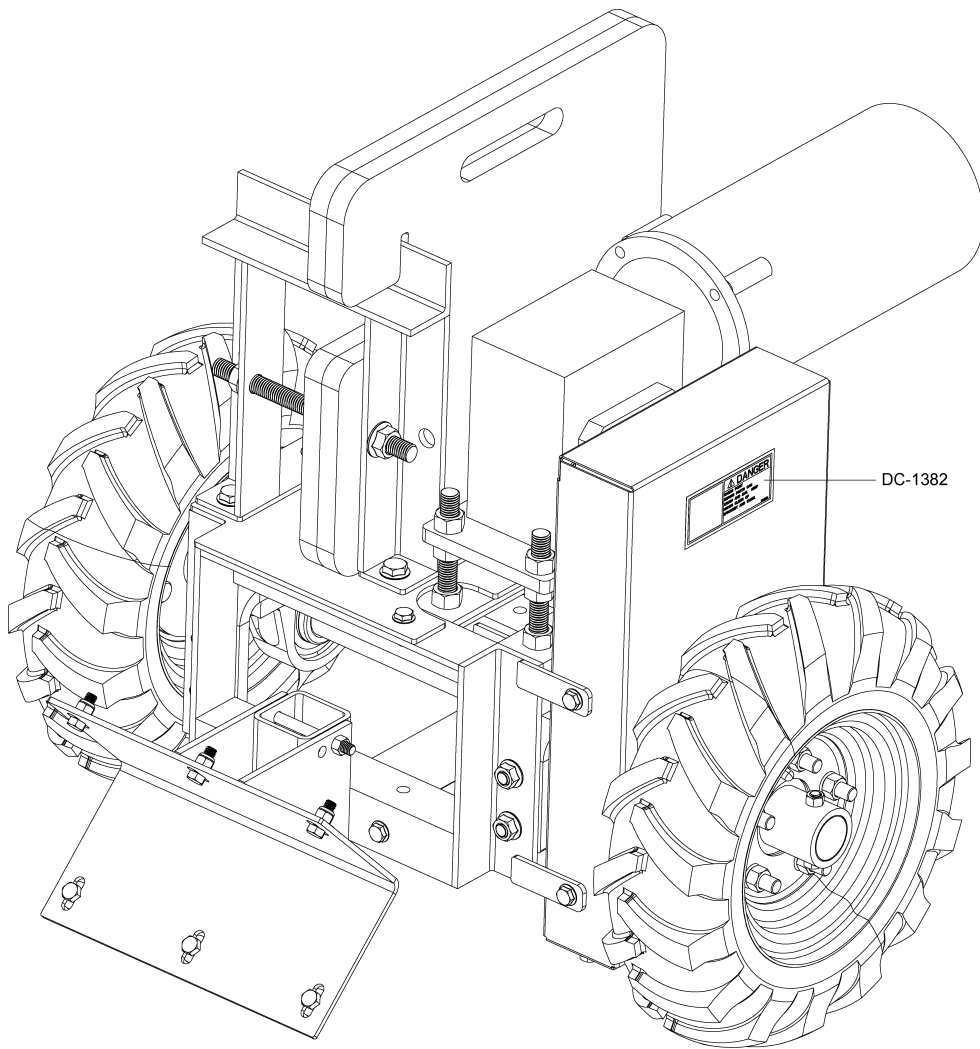

DC-1382

DC-1382

Decals located on outside of chain guards.

Sweep Tractor Assembly

1. Place the tractor frame on plain flat ground.
2. Bolt each pillow block bearing to a bearing mount bracket using two (2) 1/2"-13 x 2" hex head cap screws, two (2) flat washers and serrated flanged nuts.
3. Bolt each bearing mount bracket to the tractor frame using two (2) 1/2"-13 x 1-1/4" flange bolts and serrated flanged nuts. (See Figure 4A.)

NOTE: Lock collar flanges for each pillow block bearing must be to the inside of frame.

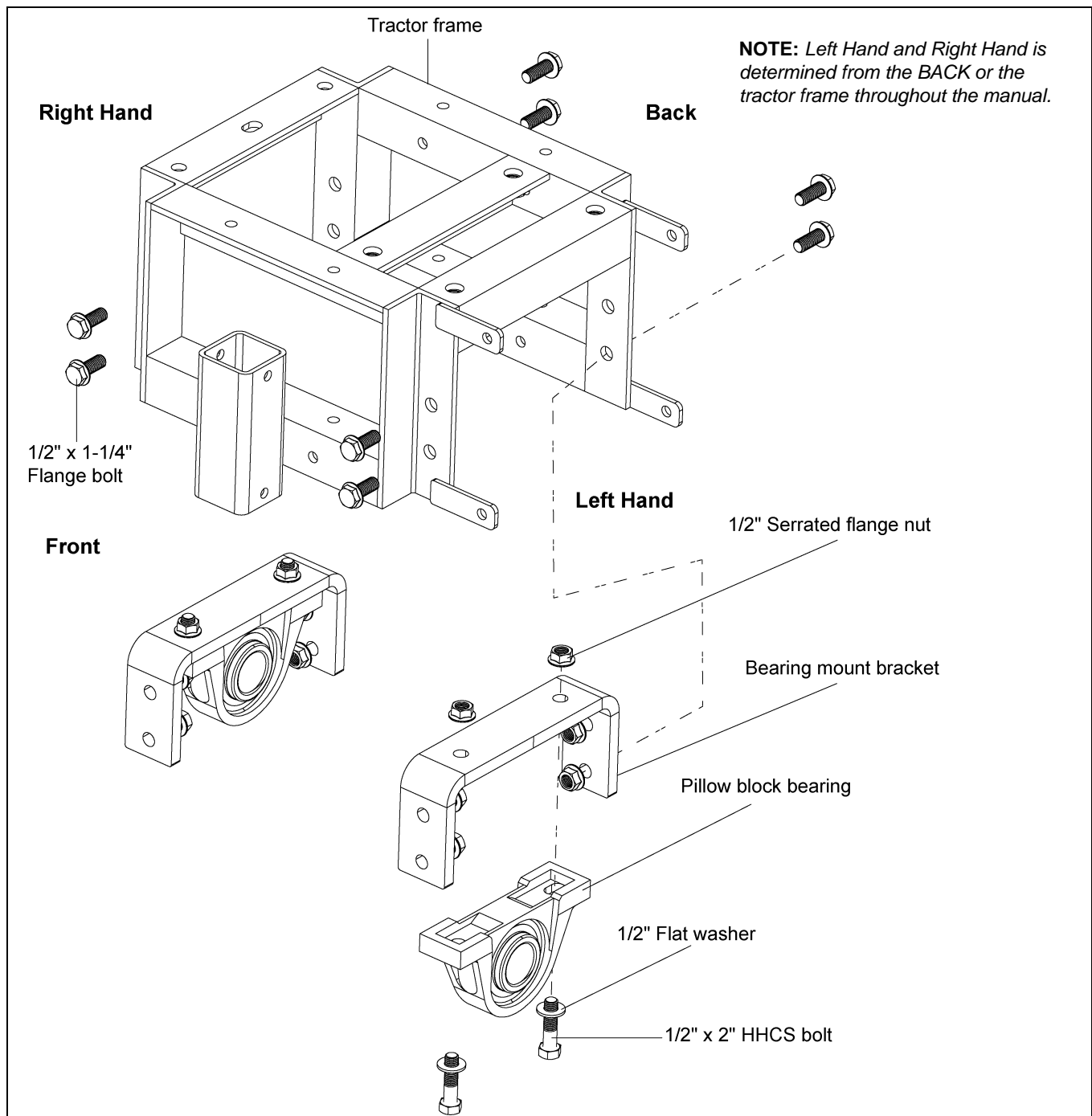

Figure 4A

4. Assembly

- Slide the tractor axle through the left side of the pillow block bearing and the lock collars so as to pass through the right side of the pillow block bearing. Make sure the keyway of the shaft is on the left hand side of the tractor.

NOTE: Do not tighten the pillow block bearing lock collars yet.

- Assemble the 40 tooth sprocket to the tractor axle using a 3/8" square x 1-3/4" key. Temporarily tighten the sprocket to the key and the shaft. Final adjustment of the sprocket placement will occur after the chain is installed.
- Mount the wheel hubs to the tractor axle using 3/8"-16 x 2-1/2" hex head cap screws and stover lock nuts. (See Figure 4B.)

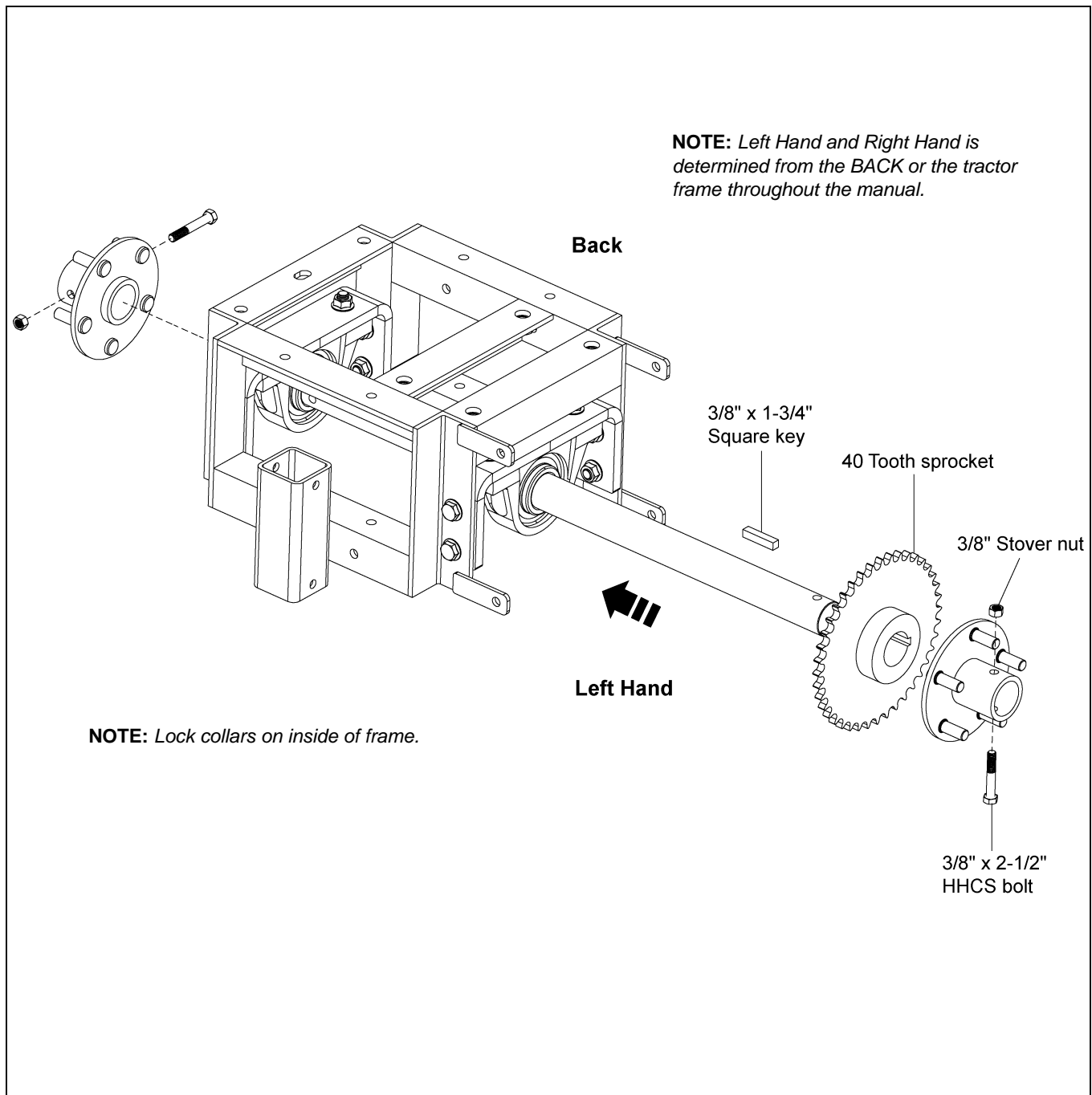

Figure 4B

- Assemble the right hand and left hand tire and wheel assemblies securely to the wheel hubs using five (5) 1/2"-20 lug nuts.

NOTE: Make sure that the tires are assembled on corresponding sides with the help of valve stem. The valve stems should point away from the tractor frame. Remove the screws or nails that are present in the tires to contain the foam in the tires when they are made. The treads of the tires should be in the forward direction. *Figure 4C* shows the proper orientation of the tire and wheel assemblies.

- Assemble the strut bracket to the tractor frame using four (4) 3/8"-16 x 1" flange bolts and serrated flange nuts. (See *Figure 4C*.)

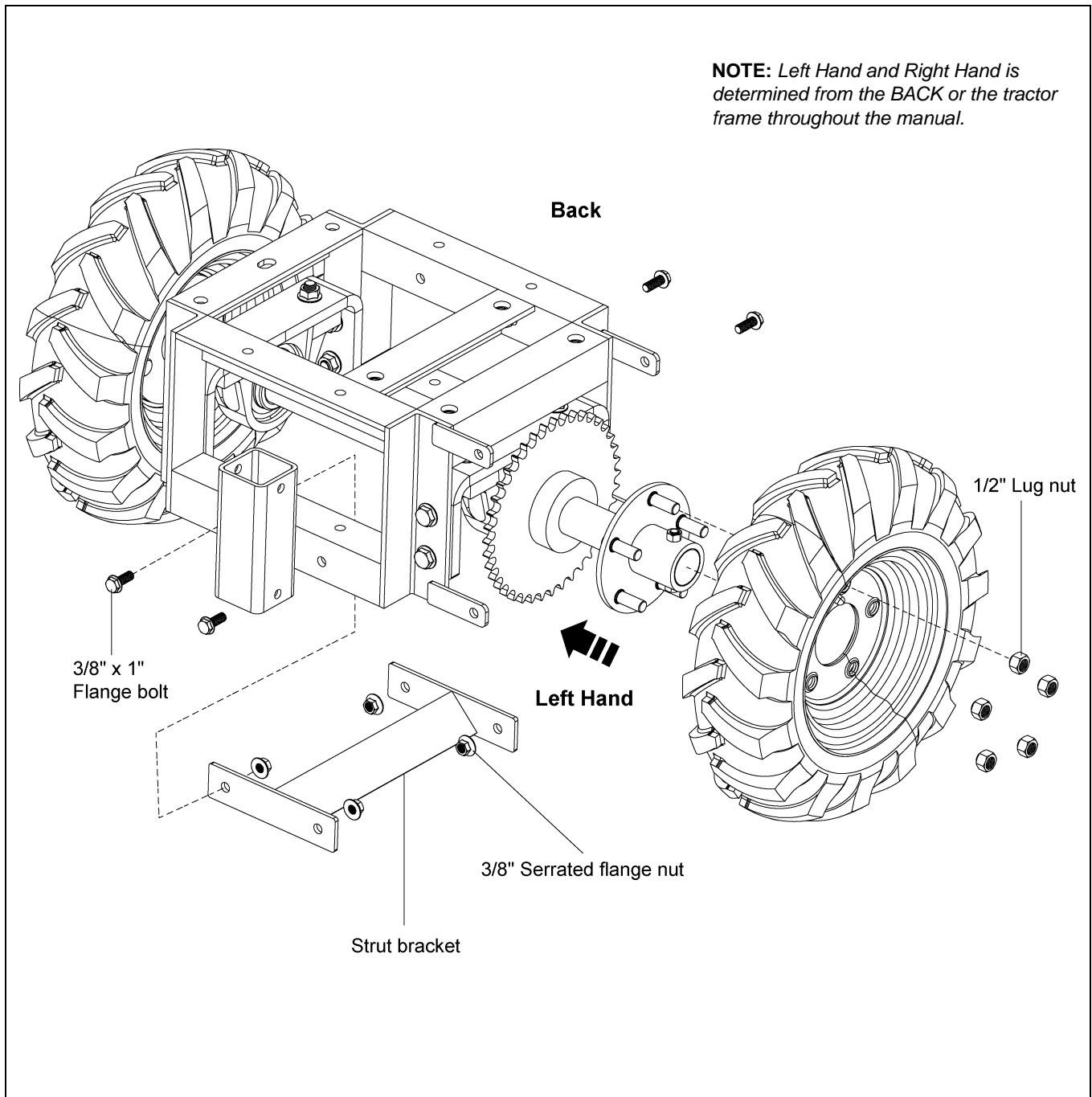

Figure 4C

4. Assembly

9. Bolt the shield bracket to the front of the tractor frame using two (2) 3/8"-16 x 3-1/2" hex head cap screws, two (2) flat washers (only on the bottom slot of the bracket) and hex nuts.
10. Attach the weight plate to the tractor frame using two (2) 3/8"-16 x 1" flange bolts and serrated flange nuts. (See Figure 4D.)

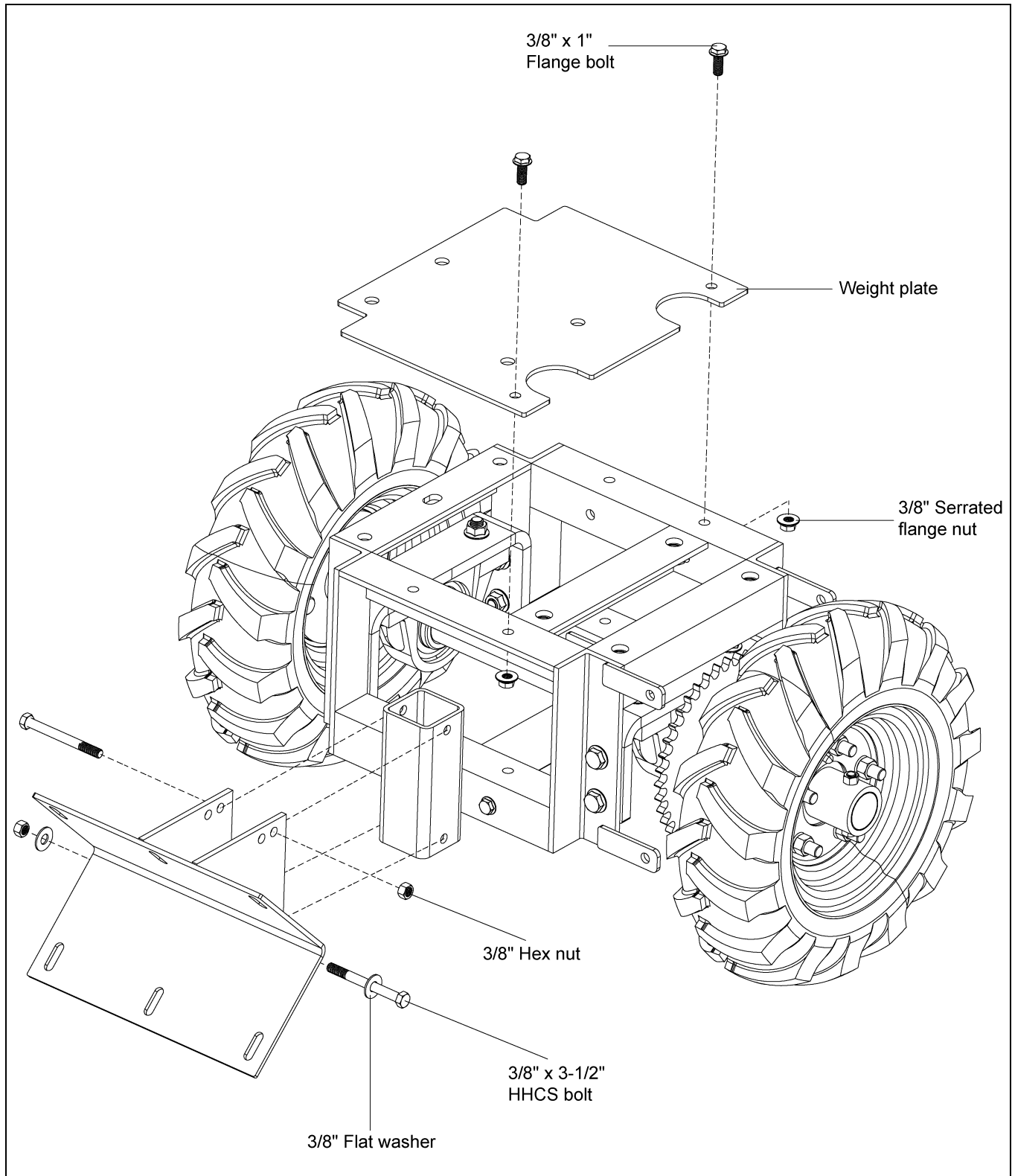

Figure 4D

11. Bolt the four (4) 5/8"-11 x 6" threaded rods to the tractor frame using one 5/8"-11 hex nut for each rod. (See Figure 4E.)

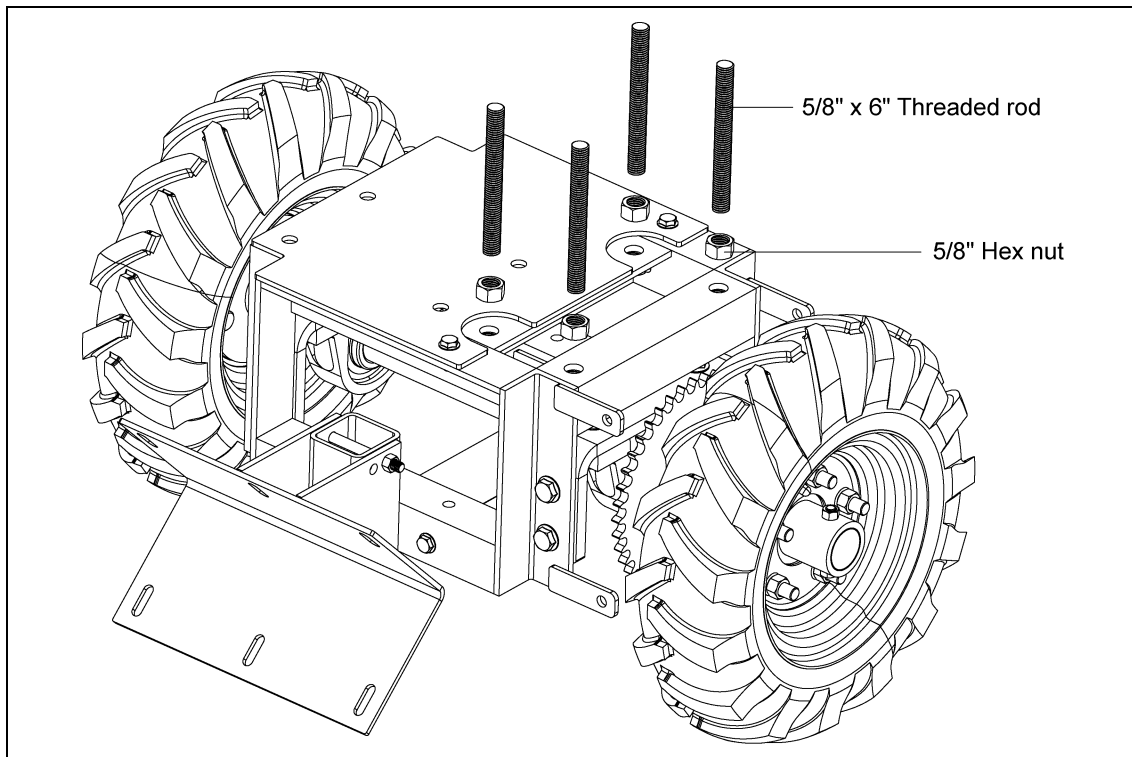

Figure 4E

12. Place one 5/8"-11 hex nut onto each rod in a temporary position. These will hold the motor plate in place. (See Figure 4F.)

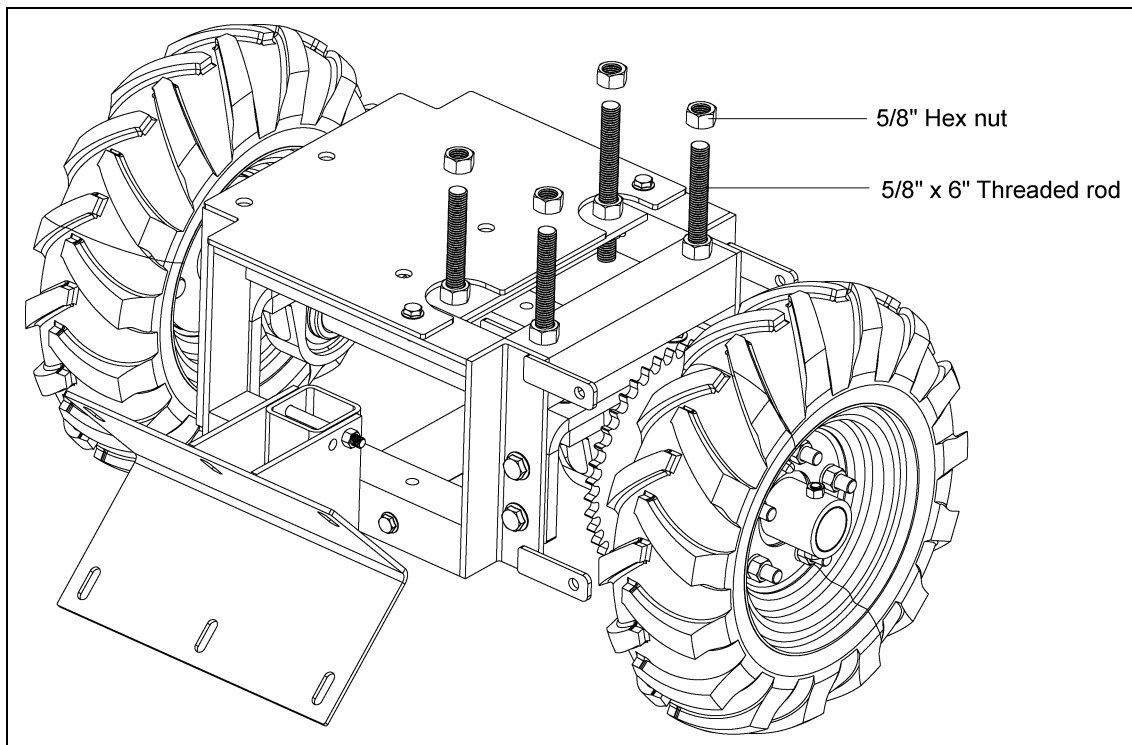

Figure 4F

4. Assembly

13. Mount the drive assembly to the gearbox plate using four (4) 3/8"-16 x 1" flange bolts. Place the gearbox plate and motor assembly over the threaded rods, resting on the hex nuts. (See Figure 4G.)

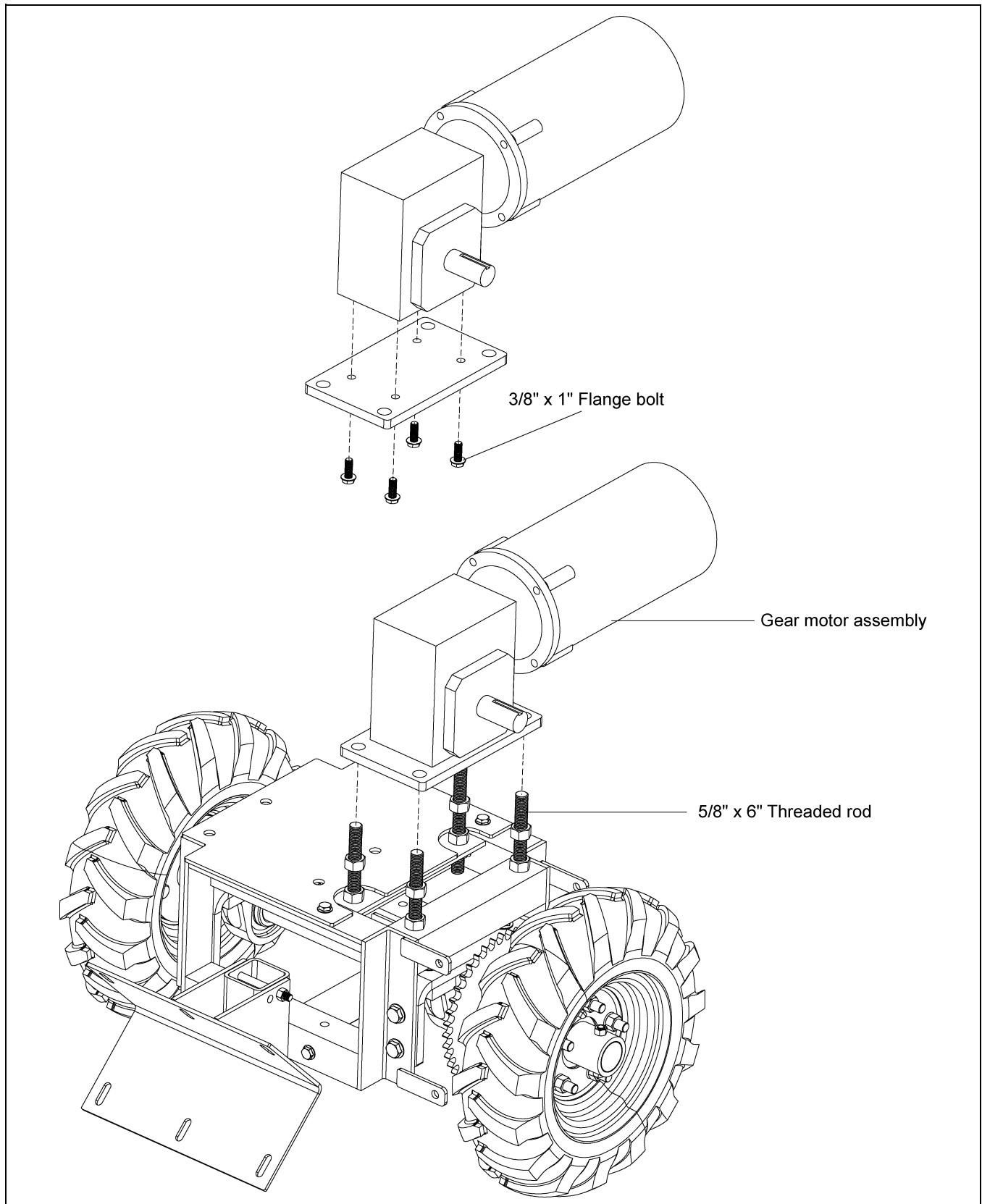

Figure 4G

14. Mount the gearbox plate and motor assembly to the 5/8"-11 x 6" threaded rod installed to the tractor frame using four (4) 5/8"-11 hex nuts.
15. Attach the weight stand to the weight plate and tractor frame with four (4) 1/2"-13 x 1-1/4" flange bolts and serrated flange nuts. (See Figure 4H.)

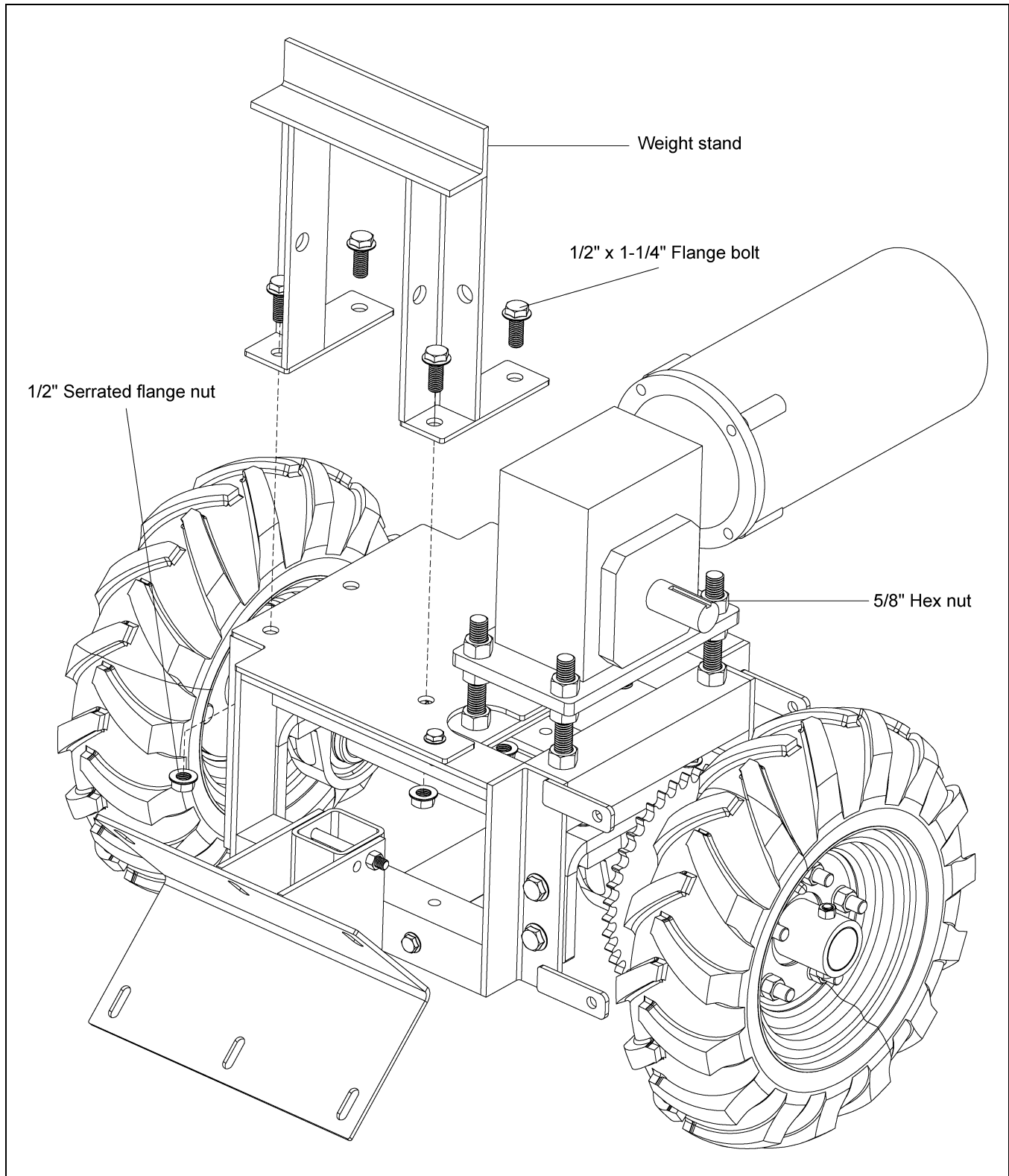

Figure 4H

4. Assembly

16. Assemble the 13 tooth sprocket to the motor shaft using a 1/4" square x 1" key.
17. Install the roller chain around both sprockets. Adjust the position each sprocket or the tractor axle (if necessary) to correctly align the chain.
18. Tighten all the sprocket set screws.
19. Tension the roller chain as required by adjusting the nuts on the 5/8"-11 x 6" threaded rods.
(See Figure 4I.)

NOTE: Tighten both pillow block bearing lock collars at this time.

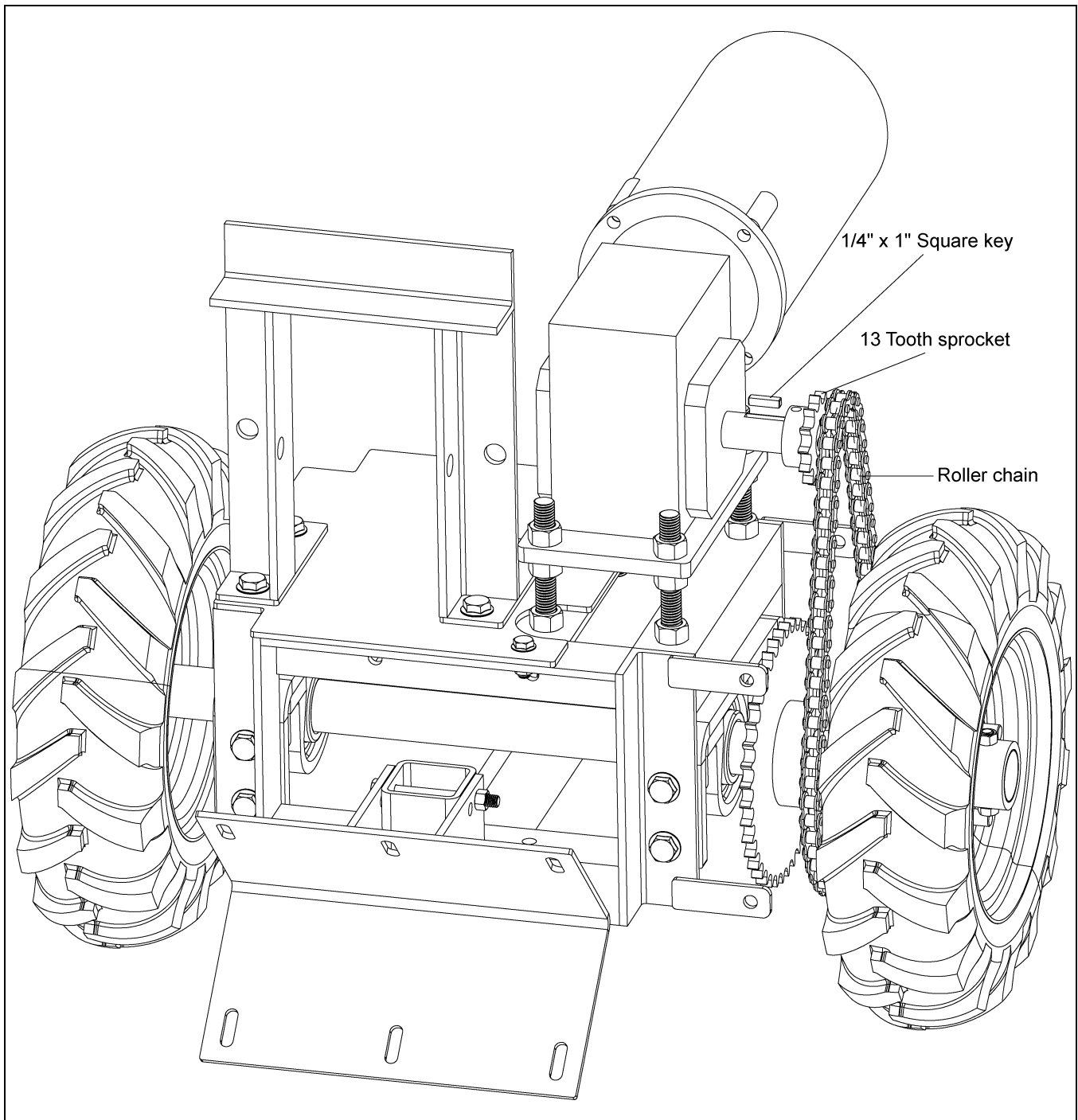

Figure 4I

20. Install the top chain guard assembly to the tractor frame using four (4) 3/8"-16 x 1" flange bolts. Slide the bottom chain guard assembly through the slot on the top chain guard and secure it with a 3/8"-16 x 3/4" flange bolt. (See Figure 4J.)

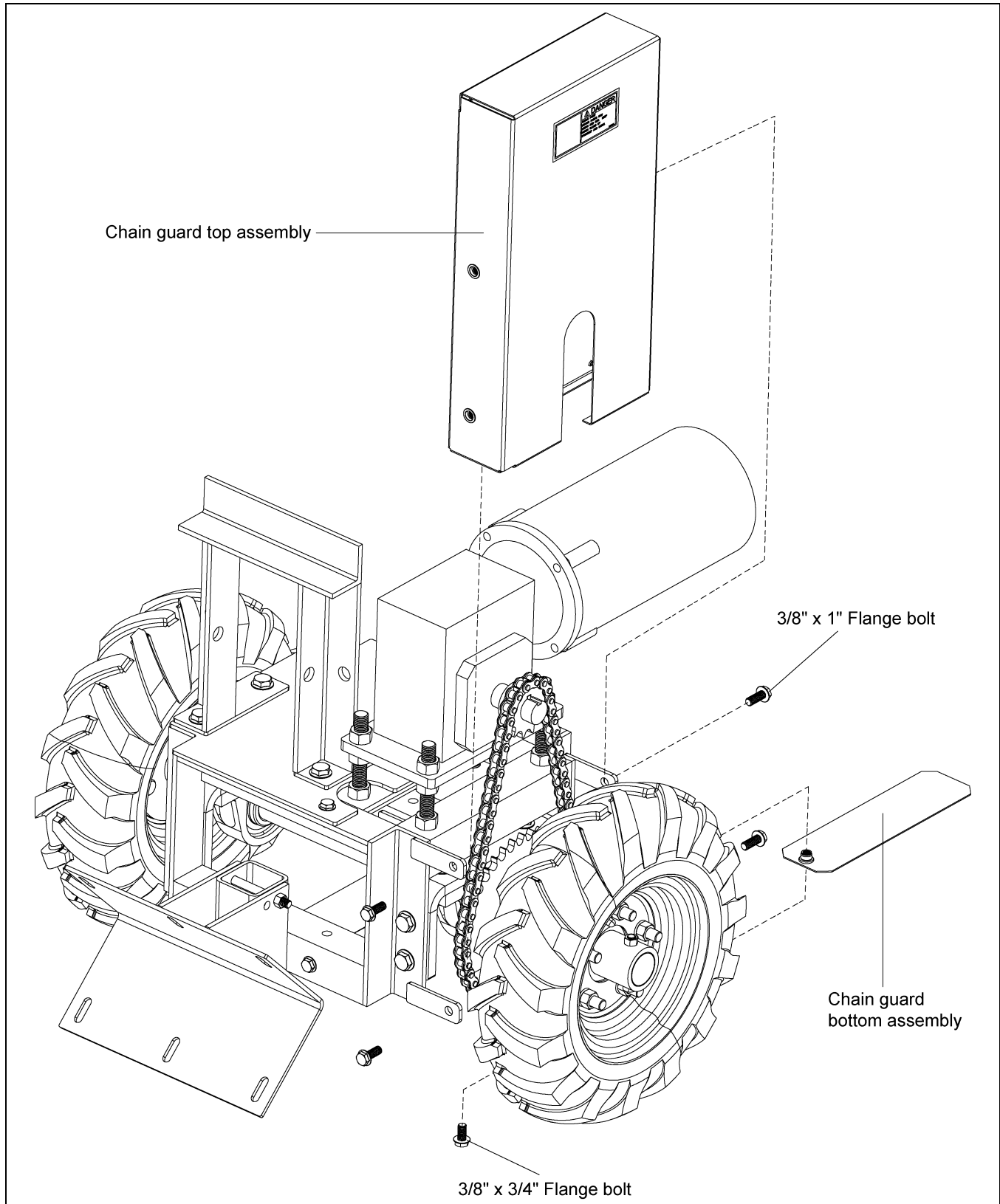

Figure 4J

4. Assembly

21. Mount the weights to the weight stand using one 5/8"-11 x 8-1/2" threaded rod and three (3) flange nuts and one flat washer. (See Figure 4K.)

NOTE: Install the weights against the left hand of the weight stand so the weight is in the middle of the tractor assembly. The weight stand can be reversed so that the weights hang over the front of the frame, if necessary. Adjust the weights to the inside of the frame to center the weight on the frame when the weight stand is reversed as described above.

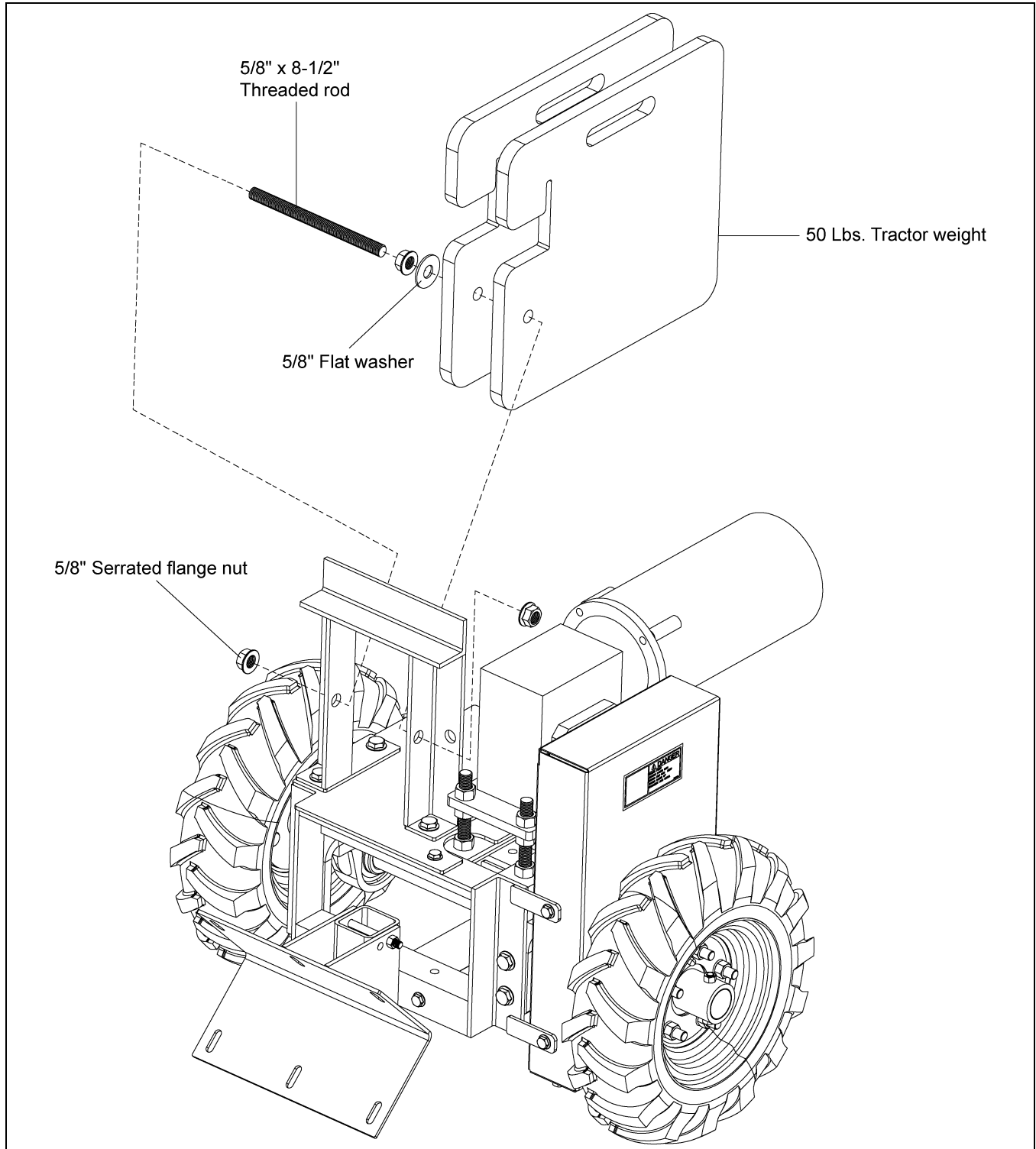

Figure 4K

End Wheel Assembly

NOTE: *If installing sweep tractor to an existing sweep, the current end wheel components must be removed.*

1. Connect the stub shaft into the sweep flight using a 5/8"-11 x 4" hex head cap screw and 5/8" stover nut.
2. Install the bearing stand assembly onto the stub shaft and bolt it to the sweep shield using two (2) 3/8" x 3" carriage bolts, flat washers and nylock nuts.
3. Install the end wheel and collar onto the end of the stub shaft. Pin the collar in place with a 1/2" x 3-1/2" hex head cap screw and prevailing torque lock nut. *(See Figure 4L.)*

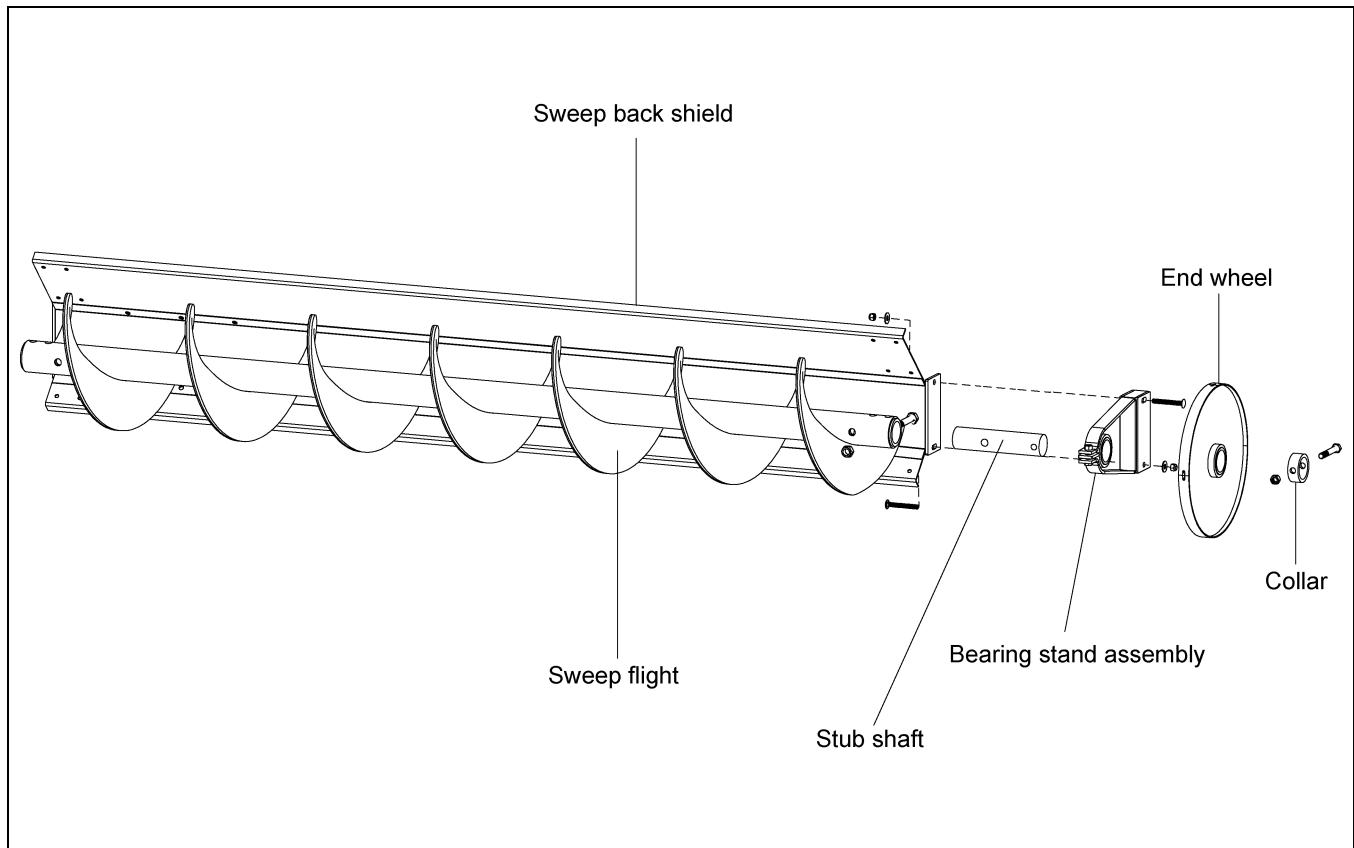

Figure 4L End Wheel Assembly

4. Assembly

Sweep Tractor to Shield Assembly

1. Position sweep tractor against the sweep shield approximately 3' from the end wheel.
2. Use the bracket on the sweep tractor to mark the location where the holes need to be drilled into the sweep shield.
3. The bolts that attach the sweep bracket to the tractor frame may need to be adjusted so that height and angle of the sweep back shield and the shield bracket are matched.
4. After marking the hole locations, drill six (6) 7/16" holes and attach the sweep tractor to the back shield using six (6) 3/8" x 1" hex head cap screws, flat washers and nylock nuts.
5. Install electric wiring for motor and controls. (*See Figure 4M.*)



All electrical wiring shall be installed by a qualified electrician and must meet the standards set by the National Electric Code and all local and state codes.

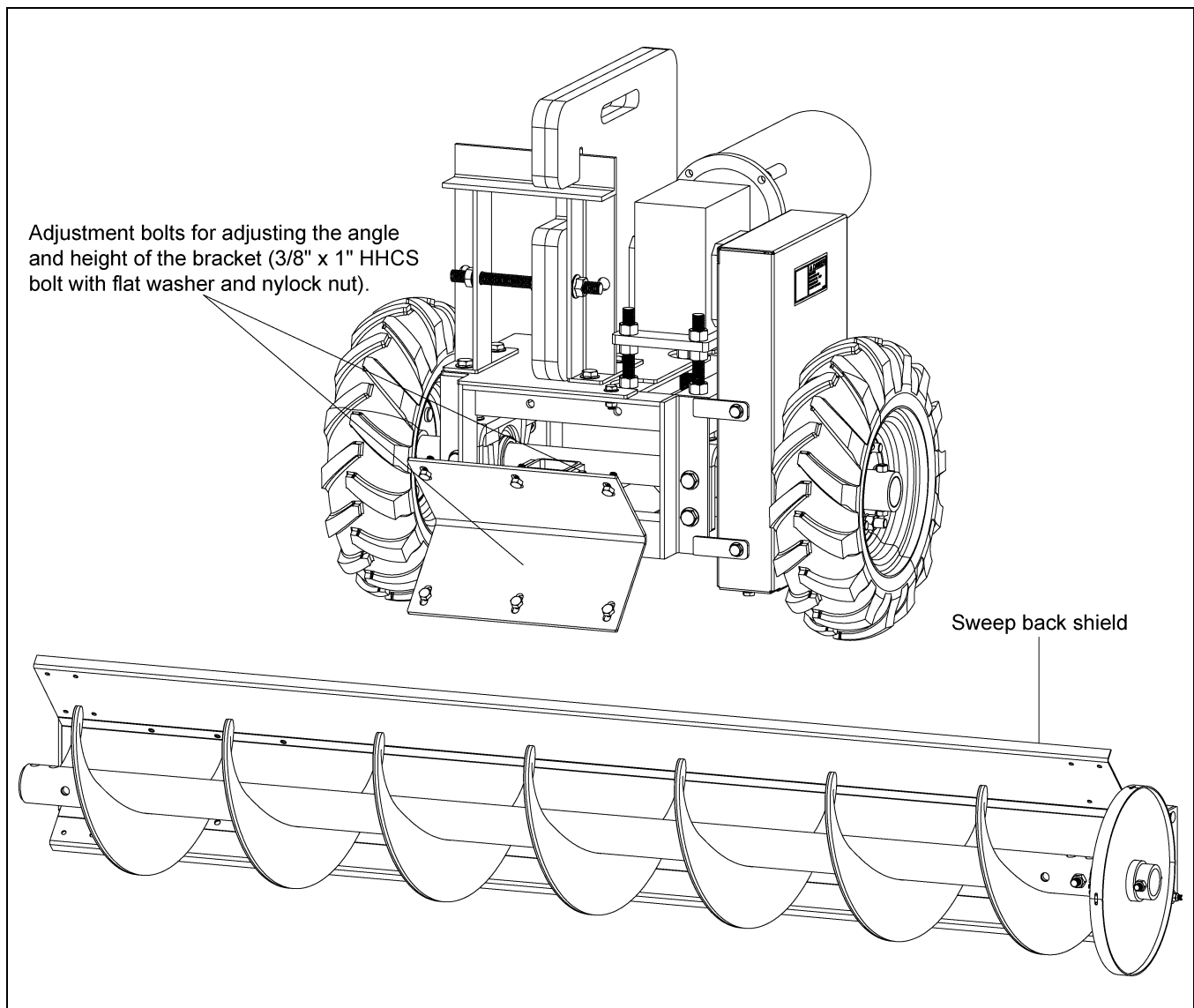
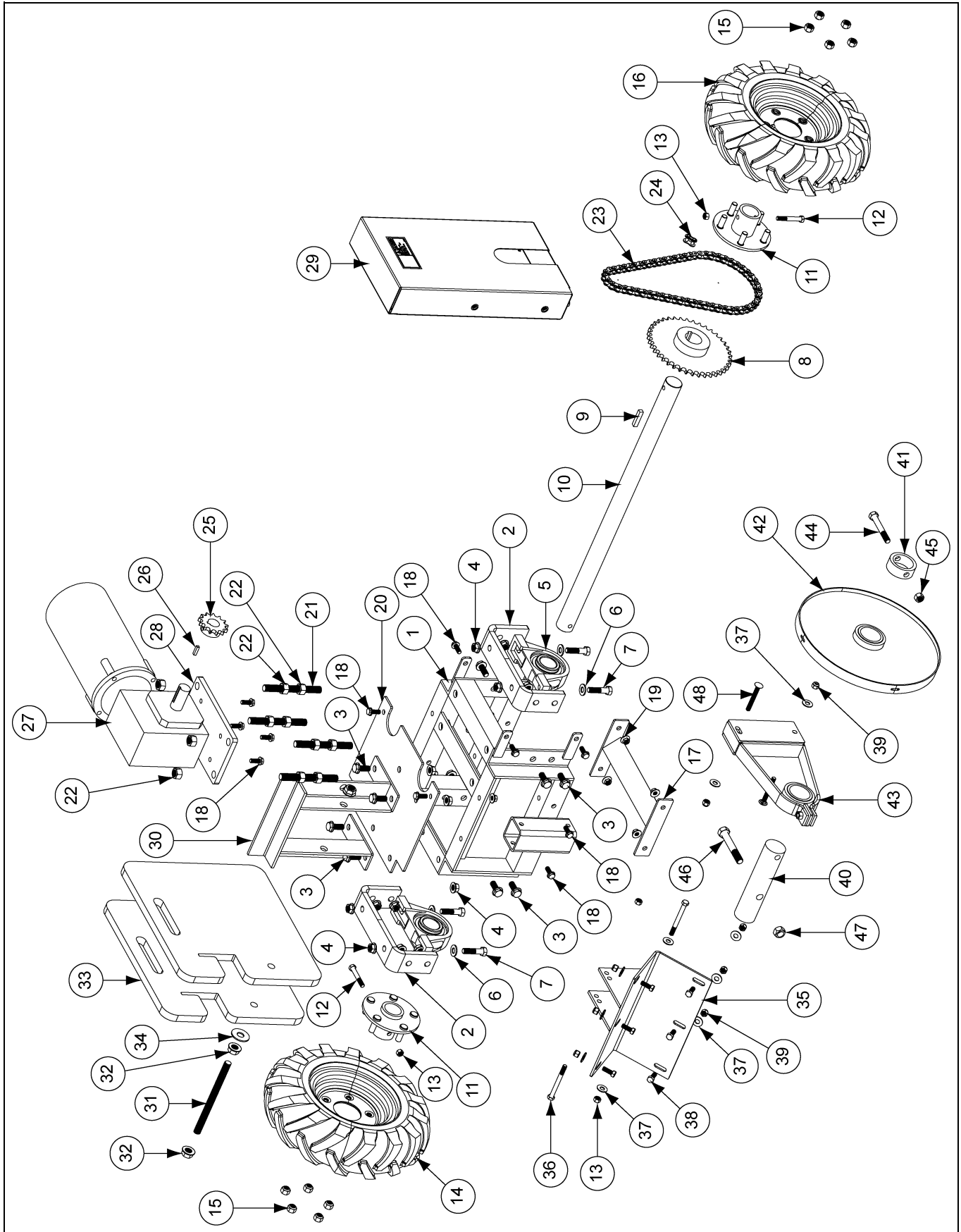

Figure 4M Sweep Tractor to Shield Assembly

1. Sweep Tractor Parts
2. Chain Guard Assembly
3. Drive Motor Assembly
4. Bearing Stand Assembly

Sweep Tractor Parts



Sweep Tractor Parts List

Ref #	Part #	Description	Ref #	Part #	Description
1	GK7714	Tractor Frame	27	GK4985	Drive Motor Assembly - 1 PH, 60 Hz, 115/230V, TEFC
2	GK7716	Bearing Mounting Bracket		GK7828	Drive Motor Assembly - 1 PH, 60 Hz, 115/208-230V, XPFC
3	S-9062	1/2"-13 x 1-1/4" Flange Bolt Zinc Grade 5		GK5481	Drive Motor Assembly - 3 PH, 60 Hz, 230/460V, TEFC
4	S-8506	1/2"-13 Serrated Flange Nut Zinc		GK6387	Drive Motor Assembly - 3 PH, 60 Hz, 208-230/460V, XPFC
5	017-1486-4	Bearing: 1-5/8" Bore Pillow Block		GK7720	Drive Motor Assembly - 3 PH, 60 Hz, 575V, XPFC
6	S-2120	1/2" Flat Washer SAE Zinc		GK6827	Drive Motor Assembly - 3 PH, 50 Hz, 220/380/460V, TEFC
7	S-7811	1/2"-13 x 2" HHCS Bolt Zinc Grade 5	28	GK7719	Drive Assembly Plate
8	GK7724	Sprocket, #50, 40 Tooth, 1-5/8" Bore, Type B	29	GK80029	Chain Guard Assembly
9	S-9179	3/8" Square x 1-3/4" Key	30	GK80117	Weight Bracket
10	GK7715	Tractor Axle	31	GK7725	5/8"-11 x 8-1/2" Threaded Rod
11	GK7718	Wheel Hub	32	S-9259	5/8"-11 Serrated Flange Nut Zinc
12	S-6762	3/8"-16 x 2-1/2" Hex Bolt Zinc Grade 5	33	GK7717	Tractor Weight - 50 Lbs.
13	S-8251	3/8"-16 Stover Nut Zinc Grade C	34	S-858	5/8" Flat Washer USS Zinc
14	GK7749	Right Tire and Wheel: 4.80-8 5-Lug, Foam Filled	35	GK4975	Shield Bracket
15	S-2698	1/2"-20 Lug Nut Grade 5	36	S-8989	3/8"-16 x 3-3/4" HHCS Bolt Zinc Grade 5
16	GK7748	Left Tire and Wheel: 4.80-8 5-Lug, Foam Filled	37	S-248	3/8" Flat Washer YDP
17	GK80116	Strut Bracket	38	S-7469	3/8"-16 x 1" HHCS Bolt Zinc Grade 5
18	S-9065	3/8"-16 x 1" Flange Bolt Zinc Grade 5	39	S-7383	3/8"-16 Nylock Nut Zinc Grade 5
19	S-968	3/8"-16 Wide Serrated Flange Nut Zinc Grade 5	40	GK4952	Stub Shaft
20	GK80115	Weight Support Plate	41	GK4951	Stub Collar
21	GC03552	5/8"-11 x 6" Threaded Rod	42	GK6457	End Wheel w/ Bearing - GCS12
22	S-4110	5/8"-11 Hex Nut Zinc Grade 5		GK4954	End Wheel w/ Bearing - GCS14
23	GK7883	Roller Chain, #50, 61 Pitch	43	GK2047	Bearing Stand Assembly - GCS12
24	D32-0015	Roller Chain Connecting Link, #50		GK80084	Bearing Stand Assembly - GCS14
25	GK4978	Sprocket, #50, 13 Tooth, 1-1/8" Bore, Type B	44	S-8314	1/2"-13 x 3-1/2" HHCS Bolt YDP Grade 8
26	S-9168	1/4" Square x 1" Key	45	S-8315	1/2"-13 Prevailing Torque Lock Nut Zinc Grade C
			46	S-7893	5/8"-11 x 4" HHCS Bolt YDP Grade 8
			47	S-8606	5/8"-11 Stover Nut Zinc Grade C
			48	S-8055	3/8"-16 x 3" Carriage Bolt Zinc Grade 5

Chain Guard Assembly

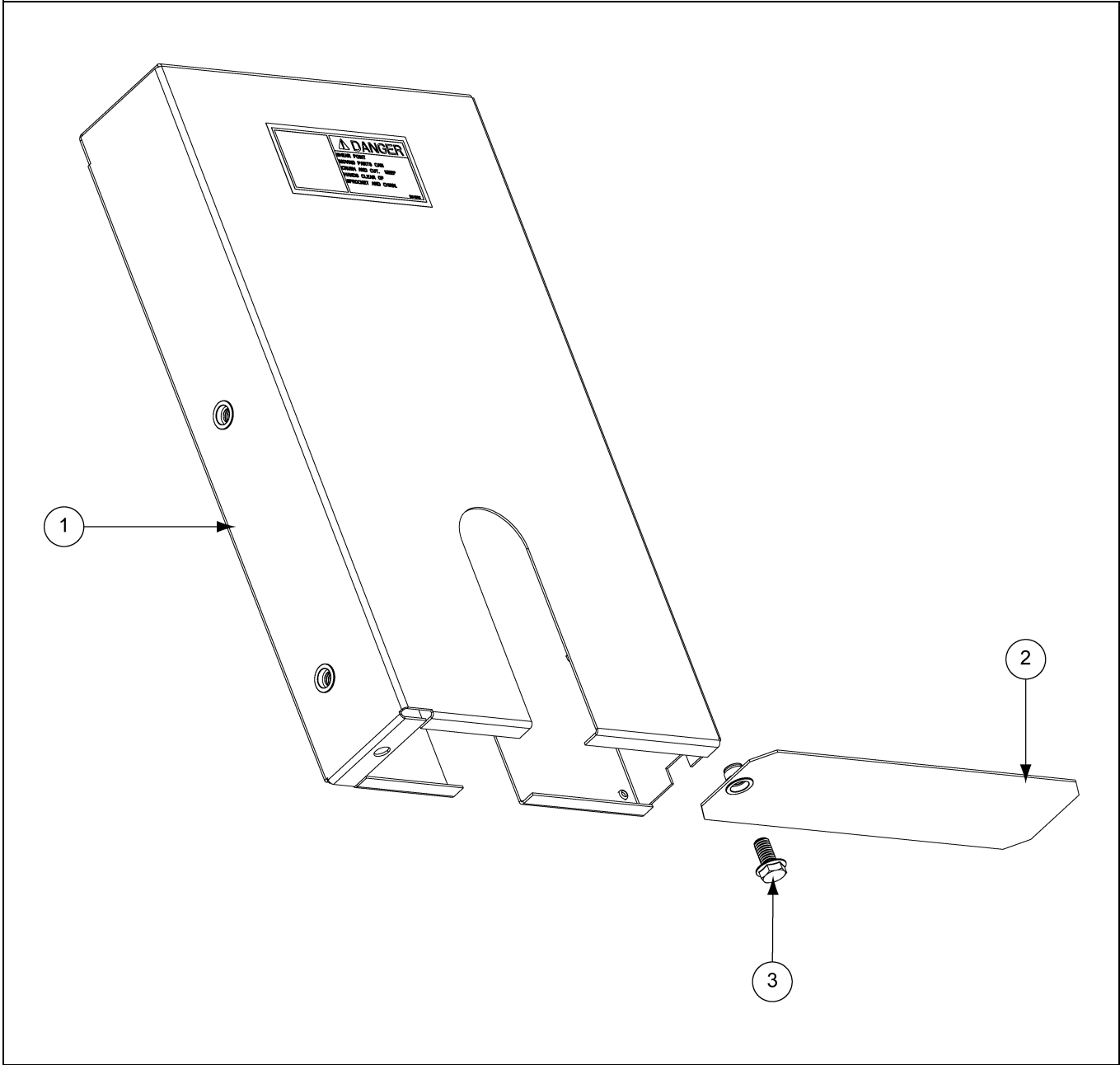

Chain Guard Assembly Parts List

Ref #	Part #	Description
1	GK7712	Chain Guard Top Assembly
2	GK7713	Chain Guard Bottom Assembly
3	S-9067	3/8"-16 x 3/4" Flange Bolt Zinc Grade 5

Drive Motor Assembly

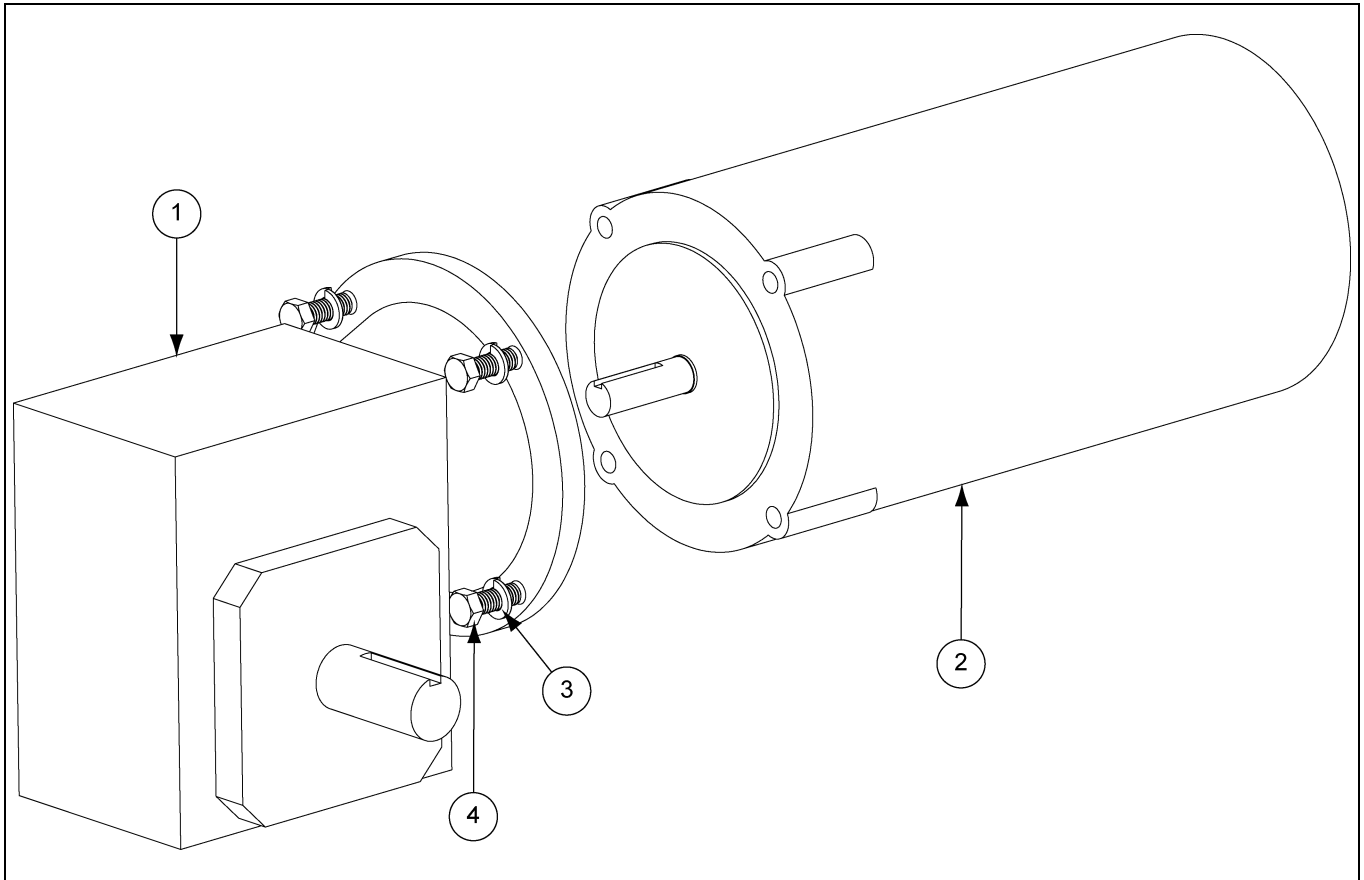

Drive Motor Assembly Parts List

Ref #	Part #	Description
1	GK4987	Worm Gear Reducer, 60:1, 56C, LO, S23
2	CFDL3504M	Motor - 1/2 HP, 1 PH, 60 Hz, 1725 RPM, 115/230V, TEFC, 56C
2	FLX-4021-1PH	Motor - 1/2 HP, 1 PH, 60 Hz, 1725 RPM, 115/208-230V, XPFC, 56C
2	FLX-3547	Motor - 1/2 HP, 3 PH, 60 Hz, 1725 RPM, 230/460V, TEFC, 56C
2	FLX-4021	Motor - 1/2 HP, 3 PH, 60 Hz, 1725 RPM, 208-230/460V, XPFC, 56C
2	012-3E-575XP	Motor - 1/2 HP, 3 PH, 60 Hz, 1725 RPM, 575V, XPFC, 56C
2	002-1408-0	Motor - 1/2 HP, 3 PH, 50 Hz, 1725 RPM, 220/380/460V, TEFC, 56C
3	S-1054	3/8" Split Lock Washer Zinc
4	S-7469	3/8"-16 x 1" HHCS Bolt Zinc Grade 5

Bearing Stand Assembly

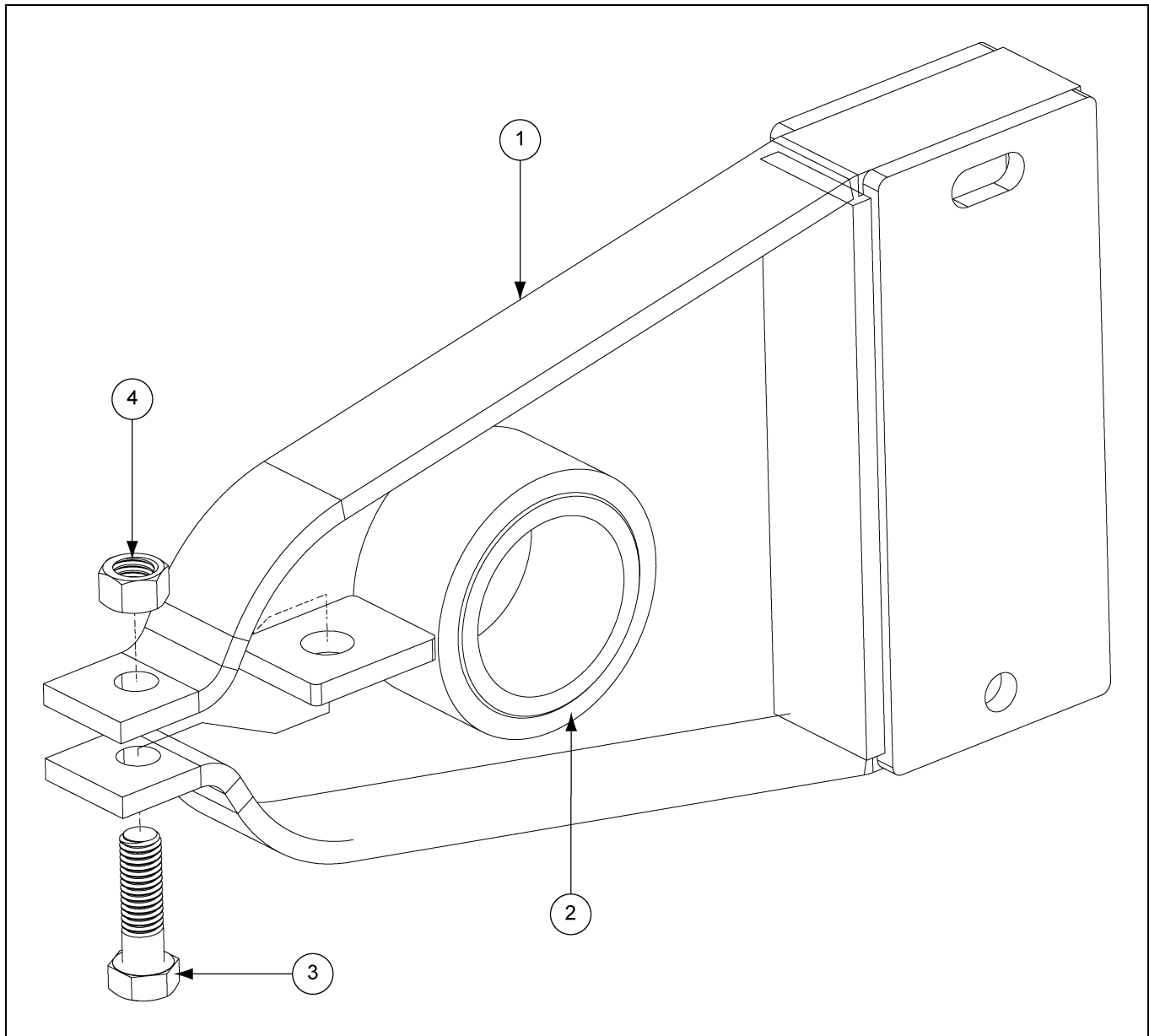

Bearing Stand Assembly Parts List

Ref #	Part #	Description
1	GK2049	Bearing Stand - GCS12
1	GK2172	Bearing Stand - GCS14
2	GK2050	Bearing Stand Bearing Assembly - GCS12
2	GK2163	Bearing Stand Bearing Assembly - GCS14
3	S-7837	7/16"-14 x 1-1/2" HHCS Bolt Zinc Grade 5
4	S-8317	7/16"-14 Stover Nut Zinc Grade C

GSI Group, LLC Limited Warranty

The GSI Group, LLC ("GSI") warrants products which it manufactures to be free of defects in materials and workmanship under normal usage and conditions for a period of 12 months after sale to the original end-user or if a foreign sale, 14 months from arrival at port of discharge, whichever is earlier. The end-user's sole remedy (and GSI's only obligation) is to repair or replace, at GSI's option and expense, products that in GSI's judgment, contain a material defect in materials or workmanship. Expenses incurred by or on behalf of the end-user without prior written authorization from the GSI Warranty Group shall be the sole responsibility of the end-user.

Warranty Extensions:

The Limited Warranty period is extended for the following products:

	Product	Warranty Period	
AP Fans and Flooring	Performer Series Direct Drive Fan Motor	3 Years	* Warranty prorated from list price: 0 to 3 years - no cost to end-user 3 to 5 years - end-user pays 25% 5 to 7 years - end-user pays 50% 7 to 10 years - end-user pays 75%
	All Fiberglass Housings	Lifetime	
	All Fiberglass Propellers	Lifetime	
Cumberland Feeding/Watering Systems	Feeder System Pan Assemblies	5 Years **	** Warranty prorated from list price: 0 to 3 years - no cost to end-user 3 to 5 years - end-user pays 50%
	Feed Tubes (1-3/4" and 2.00")	10 Years *	
	Centerless Augers	10 Years *	
	Watering Nipples	10 Years *	
Grain Systems	Grain Bin Structural Design	5 Years	† Motors, burner components and moving parts not included. Portable dryer screens included. Tower dryer screens not included.
Grain Systems Farm Fans Zimmerman	Portable and Tower Dryers	2 Years	
	Portable and Tower Dryer Frames and Internal Infrastructure †	5 Years	

GSI further warrants that the portable and tower dryer frame and basket, excluding all auger and auger drive components, shall be free from defects in materials for a period of time beginning on the twelfth (12th) month from the date of purchase and continuing until the sixtieth (60th) month from the date of purchase (extended warranty period). During the extended warranty period, GSI will replace the frame or basket components that prove to be defective under normal conditions of use without charge, excluding the labor, transportation, and/or shipping costs incurred in the performance of this extended warranty.

Conditions and Limitations:

THERE ARE NO WARRANTIES THAT EXTEND BEYOND THE LIMITED WARRANTY DESCRIPTION SET FORTH ABOVE. SPECIFICALLY, GSI MAKES NO FURTHER WARRANTY OF ANY KIND, EXPRESS OR IMPLIED, INCLUDING, WITHOUT LIMITATION, WARRANTIES OF MERCHANTABILITY OR FITNESS FOR A PARTICULAR PURPOSE OR USE IN CONNECTION WITH: (I) PRODUCT MANUFACTURED OR SOLD BY GSI OR (II) ANY ADVICE, INSTRUCTION, RECOMMENDATION OR SUGGESTION PROVIDED BY AN AGENT, REPRESENTATIVE OR EMPLOYEE OF GSI REGARDING OR RELATED TO THE CONFIGURATION, INSTALLATION, LAYOUT, SUITABILITY FOR A PARTICULAR PURPOSE, OR DESIGN OF SUCH PRODUCTS.

GSI shall not be liable for any direct, indirect, incidental or consequential damages, including, without limitation, loss of anticipated profits or benefits. The sole and exclusive remedy is set forth in the Limited Warranty, which shall not exceed the amount paid for the product purchased. This warranty is not transferable and applies only to the original end-user. GSI shall have no obligation or responsibility for any representations or warranties made by or on behalf of any dealer, agent or distributor.

GSI assumes no responsibility for claims resulting from construction defects or unauthorized modifications to products which it manufactured. Modifications to products not specifically delineated in the manual accompanying the equipment at initial sale will void the Limited Warranty.

This Limited Warranty shall not extend to products or parts which have been damaged by negligent use, misuse, alteration, accident or which have been improperly/inadequately maintained. This Limited Warranty extends solely to products manufactured by GSI.

Prior to installation, the end-user has the responsibility to comply with federal, state and local codes which apply to the location and installation of products manufactured or sold by GSI.

This equipment shall be installed in accordance with the current installation codes and applicable regulations which should be carefully followed in all cases. Authorities having jurisdiction should be consulted before installations are made.

G S I G R O U P



GSI Group
1004 E. Illinois St.
Assumption, IL 62510-0020
Phone: 1-217-226-4421
Fax: 1-217-226-4420
www.gsiag.com