

Gearbox Input Speed Reduction Packages

Installation Manual

PNEG-1716

Date: 06-08-10

GSI GROUP



PNEG-1716

Contents

Chapter 1 Safety	4
Safety Guidelines	4
Operator Qualifications	7
Chapter 2 General Information	8
Chapter 3 Installation	9
Removal and Installation	9
Chapter 4 Parts List	13
Components	13
Chapter 5 Warranty	15

Safety Guidelines

This manual contains information that is important for you, the owner/operator, to know and understand. This information relates to protecting **personal safety** and **preventing equipment problems**. It is the responsibility of the owner/operator to inform anyone operating or working in the area of this equipment of these safety guidelines. To help you recognize this information, we use the symbols that are defined below. Please read the manual and pay attention to these sections. Failure to read this manual and its safety instructions is a misuse of the equipment and may lead to serious injury or death.



This is the safety alert symbol. It is used to alert you to potential personal injury hazards. Obey all safety messages that follow this symbol to avoid possible injury or death.



DANGER indicates an imminently hazardous situation which, if not avoided, will result in death or serious injury.



WARNING indicates a potentially hazardous situation which, if not avoided, could result in death or serious injury.



CAUTION indicates a potentially hazardous situation which, if not avoided, may result in minor or moderate injury.



CAUTION used without the safety alert symbol indicates a potentially hazardous situation which, if not avoided, may result in property damage.



NOTE indicates information about the equipment that you should pay special attention.

Operate Unload Equipment Properly

- Untrained operators subject themselves and others to **SERIOUS INJURY** or **DEATH**. **NEVER** allow untrained personnel to operate this equipment.
- **NEVER** work alone.
- Keep children and other unqualified personnel out of the working area at **ALL** times. Refer to the **Start-Up** section of this manual for diagrams of the work area.
- Make sure **ALL** equipment is locked in position before operating.
- **NEVER** start equipment until **ALL** persons are clear of the work area.
- Keep hands and feet away from the auger intake and other moving parts.
- **NEVER** attempt to assist machinery operation or to remove trash from equipment while in operation.
- Be sure all operators are adequately rested and prepared to perform all functions of operating this equipment.
- **NEVER** allow any person intoxicated or under the influence of alcohol or drugs to operate the equipment.
- Make sure someone is nearby who is aware of the proper shut down sequence in the event of an accident or emergency.
- **ALWAYS** think before acting. **NEVER** act impulsively around the equipment.
- **NEVER** allow anyone inside a bin, truck or wagon which is being unloaded by an auger or conveyor. Flowing grain can trap and suffocate in seconds.
- Use ample overhead lighting after sunset to light the work area.
- Keep area around intake free of obstacles such as electrical cords, blocks, etc., that might trip workers.
- **NEVER** drive, stand or walk under the equipment.
- Use caution not to hit the auger when positioning the load.
- **ALWAYS** lock out **ALL** power to the equipment when finished unloading a bin.
- Be aware of pinch points. A pinch point is a narrow area between two surfaces that is likely to trap or catch objects and so is a potential safety hazard.



**Operate Unload
Equipment Safely**

1. Safety

Wear Protective Clothing

Wear close fitting clothing and safety equipment appropriate to the job.

Remove all jewelry.

Long hair should be tied up and back.

Safety glasses should be worn at all times to protect eyes from debris.

Wear gloves to protect your hands from sharp edges on plastic or steel parts.

Wear steel toe boots to help protect your feet from falling debris. Tuck in any loose or dangling shoe strings.

A respirator may be needed to prevent breathing potentially toxic fumes and dust.

Wear hard hat to help protect your head.

Wear appropriate fall protection equipment when working at elevations greater than six feet (6').

Eye Protection

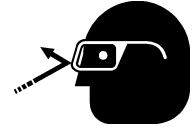

Gloves



Steel Toe Boots



Respirator



Hard Hat



Fall Protection



Operator Qualifications

- A. The User/Operator must be competent and experienced to operate auger equipment. Anyone who works with or around augers must have good common sense in order to be qualified. These persons must also know and meet all other qualifications, such as:
 - i. Any person who has not read and/or does not understand all operation and safety procedures is not qualified to operate any auger systems.
 - ii. Certain regulations apply to personnel operating power machinery. Personnel under the age of 18 years may not operate power machinery, including augers. It is your responsibility, as owner and/or supervisor, to know what these regulations are in your area or situation.
 - iii. Unqualified or incompetent persons are to remain out of the work area.
 - iv. O.S.H.A. (Occupational Safety and Health Administration) regulations state: "At the time of initial assignment and at least annually thereafter, the employer shall instruct every employee in the safe operation and servicing of all equipment with which the employee is, or will be involved". (Federal Occupational Safety and Health Standards for Agriculture. Subpart D, Section 1928.57 (a) (6)).
- B. As a requirement of O.S.H.A., it is necessary for the employer to train the employee in the safe operating and safety procedures for this auger. The sign-off sheet is provided for your convenience and personal record keeping. All unqualified persons are to stay out of the work area at all times. It is strongly recommended that another qualified person who knows the shut down procedure is in the area in the event of an emergency.

<i>Date</i>	<i>Employee Name</i>	<i>Supervisor Name</i>

2. General Information



Make certain everyone is clear before operating equipment.



The operator shall be aware of any unusual vibrations, noises and the loosening of any fasteners.



Keep all safety shields and devices in place.



Keep hands, feet and clothing away from moving parts



Shut off and lock out power to adjust, service or clean.

Removal and Installation

1. Remove the two (2) 5/16" serrated flange nuts that retain the inspection cover as shown in [Figure 3A](#).

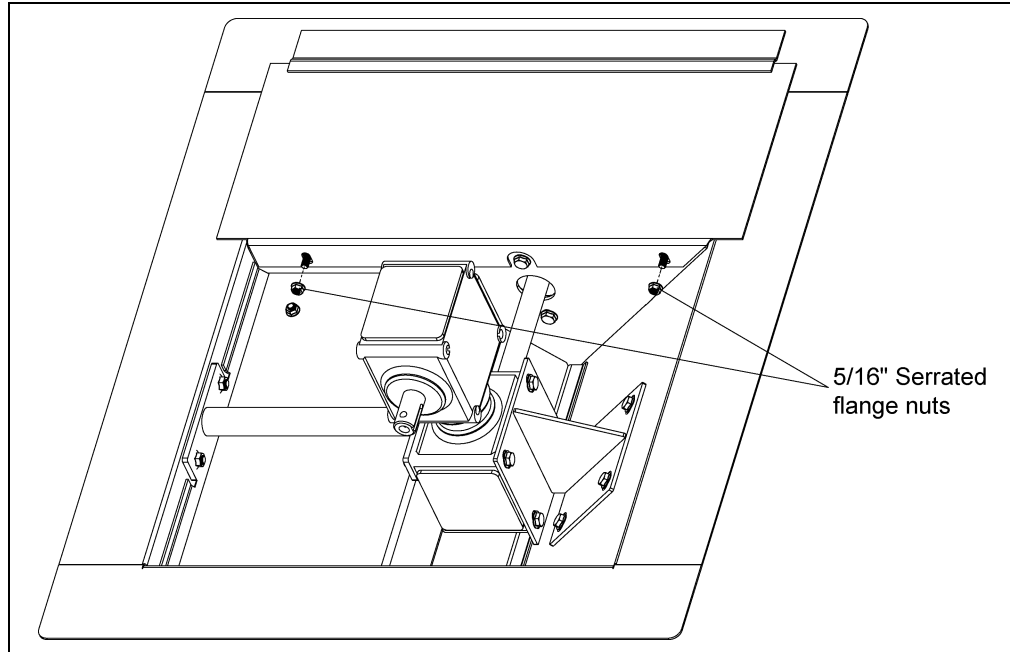

Figure 3A

2. Remove the inspection cover from the center well.
3. Unhook the idler sprocket tension spring from the idler sprocket bracket.
4. Rotate the idler sprocket bracket away from the chain.
5. Slide the clutch yoke driving jaw away from the clutch sprocket driven jaw as shown in [Figure 3B](#).

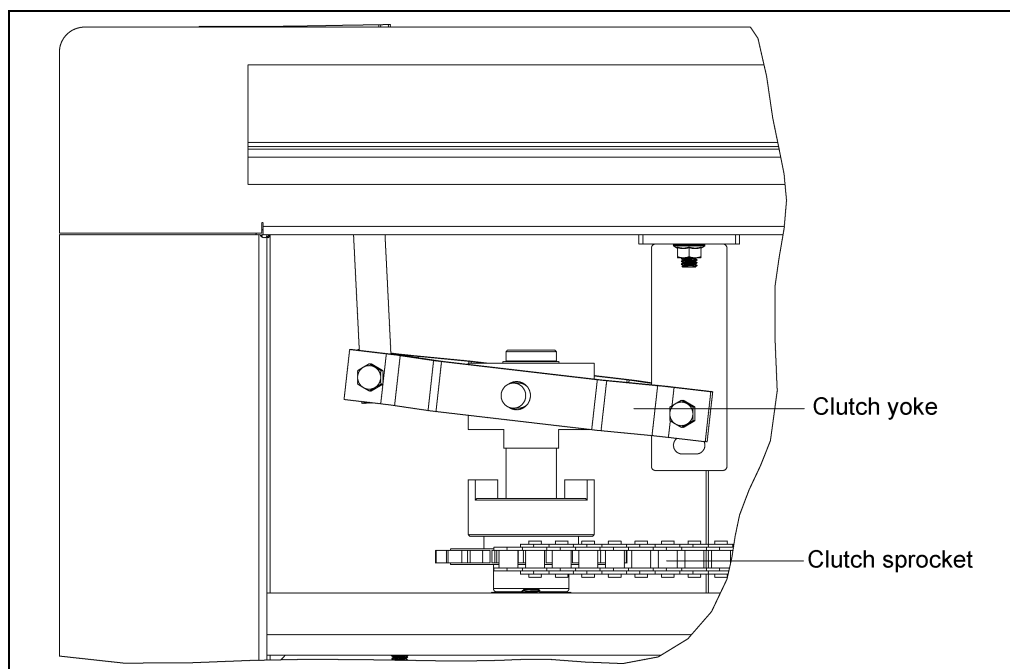

Figure 3B

3. Installation

6. Rotate the sprocket on the gearbox so that the connecting link of the chain is on the upper side.
7. Remove the connecting link from the two (2) ends of the chain.
8. Remove the chain from the center well.
9. Loosen the set screw in the sprocket that is on the gearbox input shaft.
10. Remove the sprocket and key from the gearbox input shaft as shown in [Figure 3C](#).

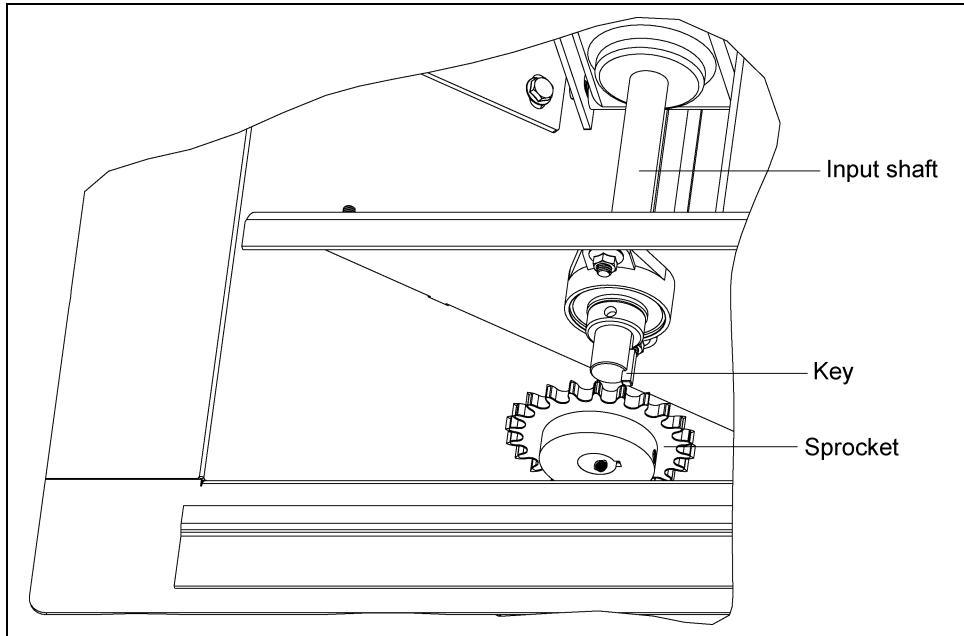

Figure 3C

11. Inspect the key for damage. Replace if necessary.
12. Install the new larger sprocket onto the input shaft of the gearbox as shown in [Figure 3D](#).

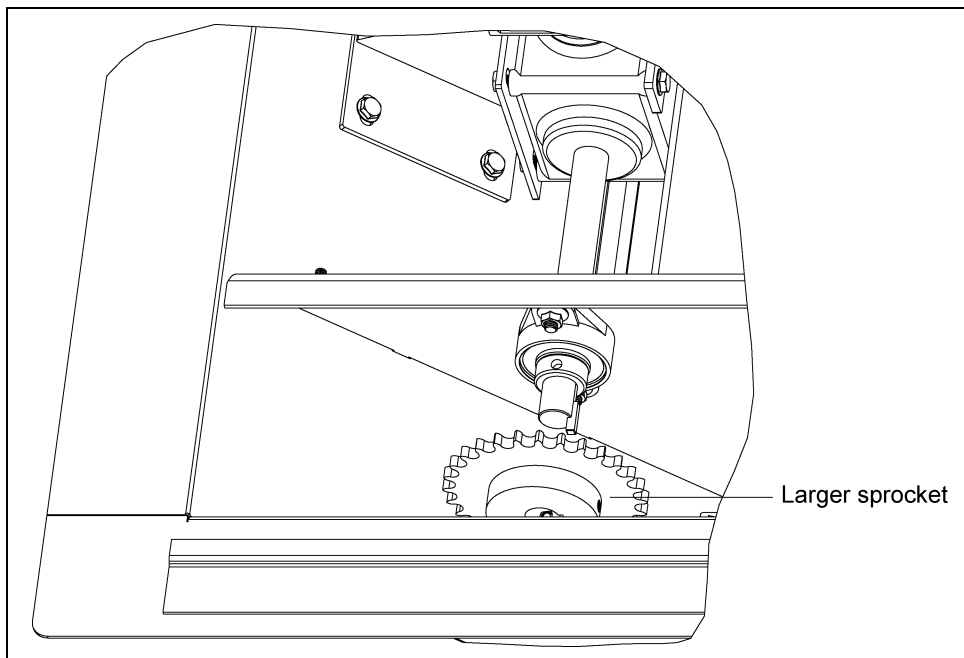

Figure 3D

13. Align the face of the gear with the face on the clutch sprocket driven jaw.

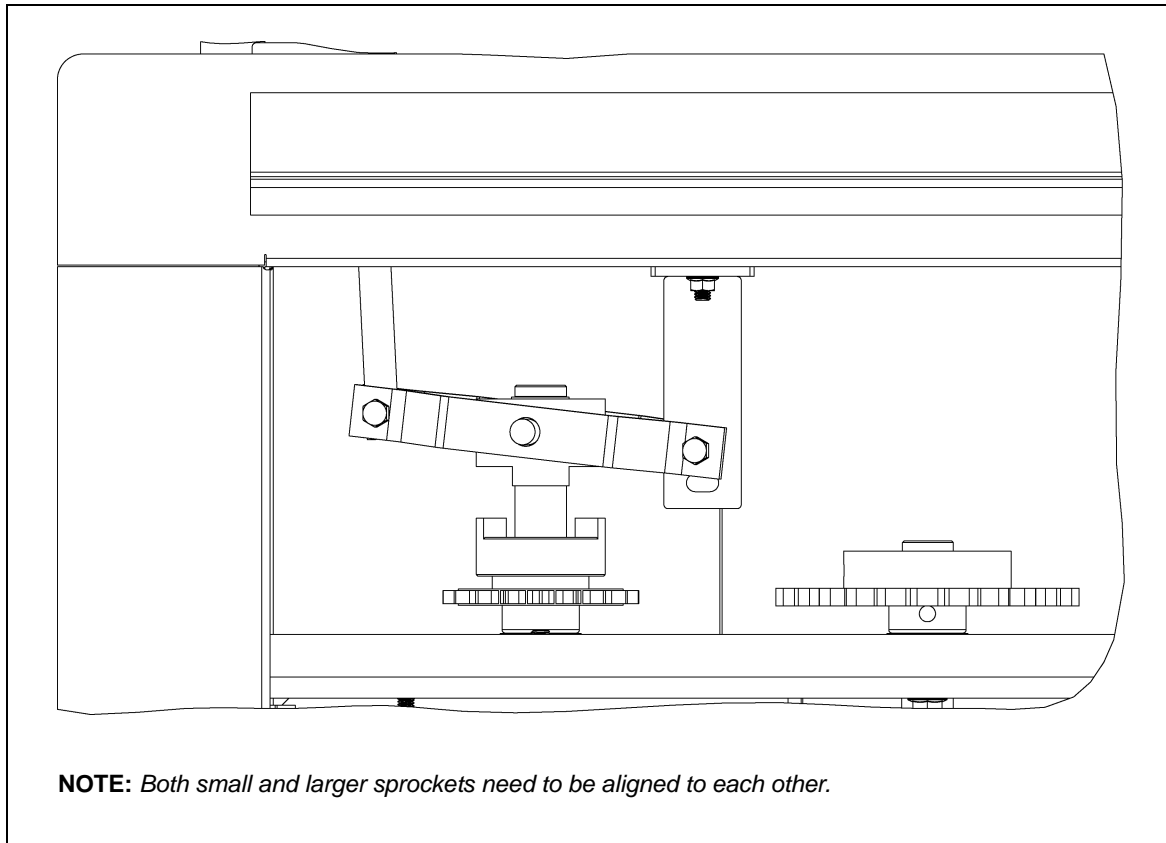

Figure 3E

14. Gently tighten the set screw in the sprocket to hold its position on the shaft. A final tightening will happen after the chain is installed.
15. Route the new longer chain around both sprockets.
16. Join the two (2) ends together with the appropriate connecting link.
17. Make a final position adjustment to the larger sprocket. It is vital that the sprocket on the input shaft of the gearbox and the clutch sprocket on the driven jaw are inline. Failure to do so will result in decreased life capacity of the chain itself and possible binding issues.
18. Once the proper position has been obtained, tighten the sprocket set screw.
19. If not already done, lubricate the chain.
20. Rotate the idler sprocket bracket back so that it engages the chain. Re-attach the idler sprocket tension spring onto the idler sprocket bracket.
21. Make sure that the clutch driving jaw has been completely disengaged from the clutch sprocket driven jaw.

3. Installation

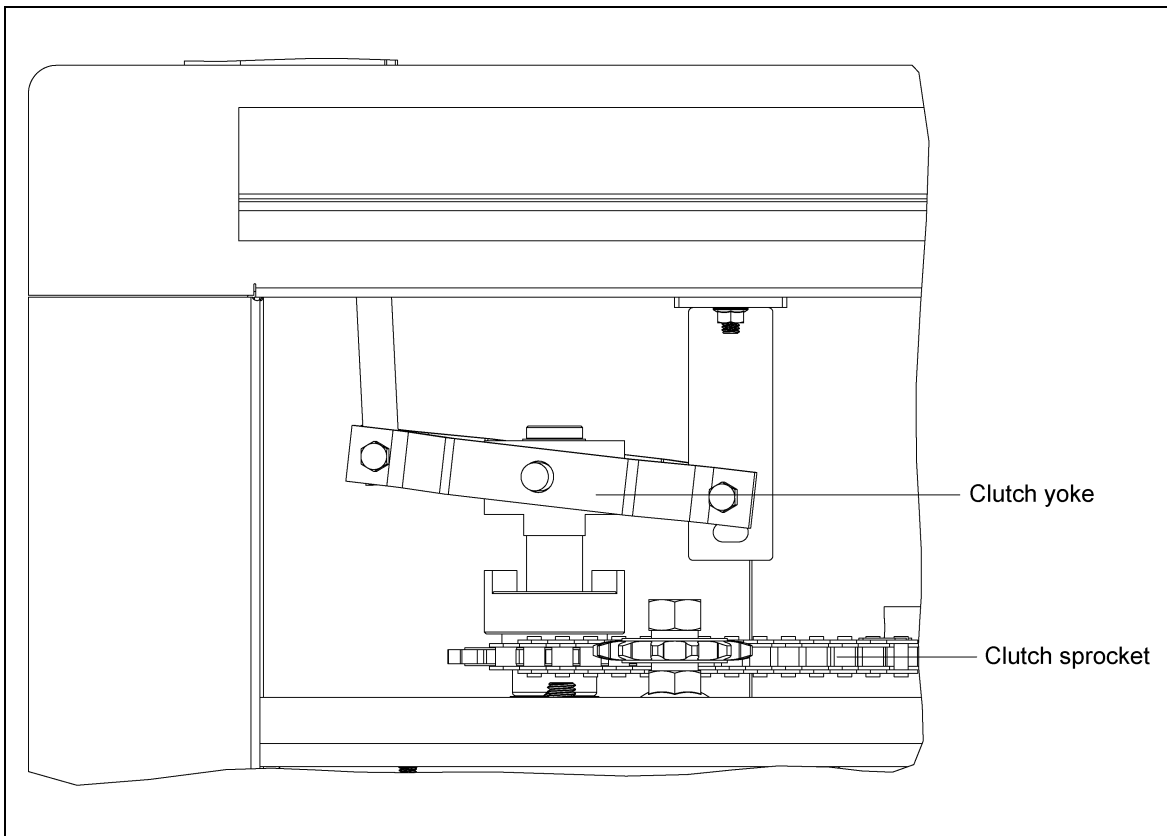
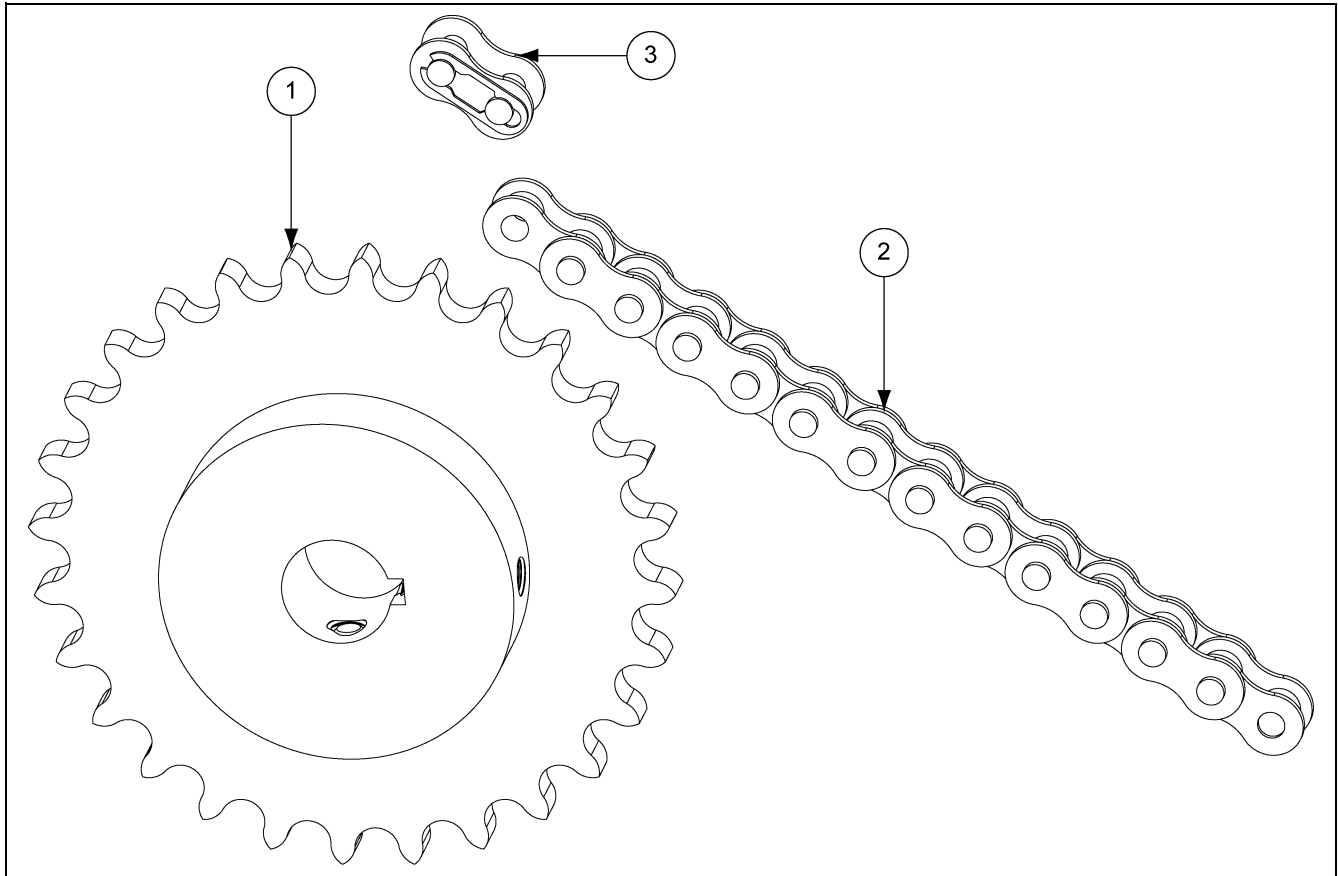

Figure 3F

22. Place the inspection cover back onto the center well.
23. Re-install the two (2) 5/16" serrated flange nuts so that the inspection cover is properly retained.

Components



19% Reduction in Sweep Arm Flight Rotation, for GPS6 and GPS8 Units Only

	Ref #	Part #	Description
GPS68GR	1	GK80004	Sprocket, #50, 27 Tooth, Hardened, 1" Bore, with Set Screws and Keyway
	2	GK1924	#50 Roller Chain, 48 Pitch
	3	D32-0015	Connecting Link, #50 Roller Chain
	3	S-8674	Offset Link, #50 Roller Chain

21% Reduction in Sweep Arm Flight Rotation, for GPS10 Units Only

	Ref #	Part #	Description
GPS10GR	1	GK80005	Sprocket, #50, 28 Tooth, Hardened, 1" Bore, with Set Screws and Keyway
	2	GK80006	#50 Roller Chain, 52 Pitch
	3	D32-0015	Connecting Link, #50 Roller Chain
	3	S-8674	Offset Link, #50 Roller Chain

32% Reduction in Sweep Arm Flight Rotation, for CPS10 Units Only

	Ref #	Part #	Description
CPS10GR	1	GK2324	Sprocket, #60, 22 Tooth, Hardened, 1-1/4" Bore, with Set Screws and Keyway
	2	GK4947	#60 Roller Chain, 45 Pitch
	3	S-8618	Connecting Link, #60 Roller Chain
	3	S-8619	Offset Link, #60 Roller Chain

NOTES

GSI Group, LLC Limited Warranty

The GSI Group, LLC ("GSI") warrants products which it manufactures to be free of defects in materials and workmanship under normal usage and conditions for a period of 12 months after sale to the original end-user or if a foreign sale, 14 months from arrival at port of discharge, whichever is earlier. The end-user's sole remedy (and GSI's only obligation) is to repair or replace, at GSI's option and expense, products that in GSI's judgment, contain a material defect in materials or workmanship. Expenses incurred by or on behalf of the end-user without prior written authorization from the GSI Warranty Group shall be the sole responsibility of the end-user.

Warranty Extensions:

The Limited Warranty period is extended for the following products:

	Product	Warranty Period	
AP Fans and Flooring	Performer Series Direct Drive Fan Motor	3 Years	* Warranty prorated from list price: 0 to 3 years - no cost to end-user 3 to 5 years - end-user pays 25% 5 to 7 years - end-user pays 50% 7 to 10 years - end-user pays 75%
	All Fiberglass Housings	Lifetime	
	All Fiberglass Propellers	Lifetime	
Cumberland Feeding/Watering Systems	Feeder System Pan Assemblies	5 Years **	** Warranty prorated from list price: 0 to 3 years - no cost to end-user 3 to 5 years - end-user pays 50%
	Feed Tubes (1-3/4" and 2.00")	10 Years *	
	Centerless Augers	10 Years *	
	Watering Nipples	10 Years *	
Grain Systems	Grain Bin Structural Design	5 Years	
Grain Systems Farm Fans Zimmerman	Portable and Tower Dryers	2 Years	† Motors, burner components and moving parts not included. Portable dryer screens included. Tower dryer screens not included.
	Portable and Tower Dryer Frames and Internal Infrastructure †	5 Years	

GSI further warrants that the portable and tower dryer frame and basket, excluding all auger and auger drive components, shall be free from defects in materials for a period of time beginning on the twelfth (12th) month from the date of purchase and continuing until the sixtieth (60th) month from the date of purchase (extended warranty period). During the extended warranty period, GSI will replace the frame or basket components that prove to be defective under normal conditions of use without charge, excluding the labor, transportation, and/or shipping costs incurred in the performance of this extended warranty.

Conditions and Limitations:

THERE ARE NO WARRANTIES THAT EXTEND BEYOND THE LIMITED WARRANTY DESCRIPTION SET FORTH ABOVE. SPECIFICALLY, GSI MAKES NO FURTHER WARRANTY OF ANY KIND, EXPRESS OR IMPLIED, INCLUDING, WITHOUT LIMITATION, WARRANTIES OF MERCHANTABILITY OR FITNESS FOR A PARTICULAR PURPOSE OR USE IN CONNECTION WITH: (I) PRODUCT MANUFACTURED OR SOLD BY GSI OR (II) ANY ADVICE, INSTRUCTION, RECOMMENDATION OR SUGGESTION PROVIDED BY AN AGENT, REPRESENTATIVE OR EMPLOYEE OF GSI REGARDING OR RELATED TO THE CONFIGURATION, INSTALLATION, LAYOUT, SUITABILITY FOR A PARTICULAR PURPOSE, OR DESIGN OF SUCH PRODUCTS.

GSI shall not be liable for any direct, indirect, incidental or consequential damages, including, without limitation, loss of anticipated profits or benefits. The sole and exclusive remedy is set forth in the Limited Warranty, which shall not exceed the amount paid for the product purchased. This warranty is not transferable and applies only to the original end-user. GSI shall have no obligation or responsibility for any representations or warranties made by or on behalf of any dealer, agent or distributor.

GSI assumes no responsibility for claims resulting from construction defects or unauthorized modifications to products which it manufactured. Modifications to products not specifically delineated in the manual accompanying the equipment at initial sale will void the Limited Warranty.

This Limited Warranty shall not extend to products or parts which have been damaged by negligent use, misuse, alteration, accident or which have been improperly/inadequately maintained. This Limited Warranty extends solely to products manufactured by GSI.

Prior to installation, the end-user has the responsibility to comply with federal, state and local codes which apply to the location and installation of products manufactured or sold by GSI.

This equipment shall be installed in accordance with the current installation codes and applicable regulations which should be carefully followed in all cases. Authorities having jurisdiction should be consulted before installations are made.

G S I G R O U P



GSI Group
1004 E. Illinois St.
Assumption, IL 62510-0020
Phone: 1-217-226-4421
Fax: 1-217-226-4420
www.gsiag.com