

# U-Trough Direct Gear Drive Bin Sweep Auger Unload Systems

Installation Instructions and  
Operator's Manual

PNEG-1735

Version: 4.0

Date: 09-04-20



PNEG-1735

---

**All information, illustrations, photos and specifications in this manual are based on the latest information available at the time of publication. The right is reserved to make changes at any time without notice.**

# Contents

<b>Chapter 1 Safety</b> .....	<b>4</b>
Safety Guidelines .....	4
Cautionary Symbols Definitions .....	5
Safety Cautions .....	6
Safety Sign-Off Sheet .....	9
<b>Chapter 2 Decals</b> .....	<b>10</b>
Safety Decal Location .....	10
<b>Chapter 3 Machine Components</b> .....	<b>12</b>
U-Trough Unload Components .....	12
<b>Chapter 4 Installation</b> .....	<b>13</b>
Installation Under Aeration Floor .....	13
Installation in Concrete Foundation .....	17
Sweep Drive .....	18
Sweep Arm .....	21
Horizontal Drive Unit .....	26
Incline Elbow .....	29
<b>Chapter 5 Power Requirements</b> .....	<b>31</b>
Electric Drive .....	31
Pulley Selection .....	33
<b>Chapter 6 Operation</b> .....	<b>35</b>
Pre-Operation Check List .....	35
<b>Chapter 7 Service</b> .....	<b>38</b>
Gearbox Oil Level .....	38
Grease Points .....	39
<b>Chapter 8 Unload Dimensions</b> .....	<b>40</b>
U-Trough Unload Dimensions .....	40
Bin Sweep Dimensions .....	42
<b>Chapter 9 Warranty</b> .....	<b>43</b>

### Safety Guidelines

Safety guidelines are general-to-specific safety rules that must be followed at all times. This manual is written to help you understand safe operating procedures and problems that can be encountered by the operator and other personnel when using this equipment. Read and save these instructions.

As owner or operator, you are responsible for understanding the requirements, hazards, and precautions that exist and to inform others as required. Unqualified persons must stay out of the work area at all times.

Alterations must not be made to the equipment. Alterations can produce dangerous situations resulting in **SERIOUS INJURY** or **DEATH**.

This equipment must be installed in accordance with the current installation codes and applicable regulations, which must be carefully followed in all cases. Authorities having jurisdiction must be consulted before installations are made.

When necessary, you must consider the installation location relative to electrical, fuel and water utilities.

Personnel operating or working around equipment must read this manual. This manual must be delivered with equipment to its owner. Failure to read this manual and its safety instructions is a misuse of the equipment.

**ST-0001-4**

## Cautionary Symbols Definitions

Cautionary symbols appear in this manual and on product decals. The symbols alert the user of potential safety hazards, prohibited activities and mandatory actions. To help you recognize this information, we use the symbols that are defined below.



This symbol indicates an imminently hazardous situation which, if not avoided, **will result in serious injury or death.**



This symbol indicates a potentially hazardous situation which, if not avoided, **can result in serious injury or death.**



This symbol indicates a potentially hazardous situation which, if not avoided, **can result in minor or moderate injury.**



This symbol is used to address practices not related to personal injury.



This symbol indicates a general hazard.



This symbol indicates a prohibited activity.

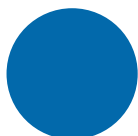

This symbol indicates a mandatory action.

ST-0005-2

## Safety Cautions

### Use Personal Protective Equipment

- Use appropriate personal protective equipment:

**Eye Protection**



**Respiratory Protection**



**Foot Protection**



**Hearing Protection**



**Head Protection**



**Fall Protection**



**Hand Protection**



- Wear clothing appropriate to the job.
- Remove all jewelry.
- Tie long hair up and back.

ST-0004-1

### Follow Safety Instructions

- Carefully read all safety messages in this manual and safety signs on your machine. Keep signs in good condition. Replace missing or damaged safety signs. Be sure new equipment components and repair parts include the current safety signs. Replacement safety signs are available from the manufacturer.
- Learn how to operate the machine and how to use controls properly. Do not let anyone operate without instruction.
- If you do not understand any part of this manual or need assistance, contact your dealer.



ST-0002-1

### Maintain Equipment and Work Area

- Understand service procedures before doing work. Keep area clean and dry.
- Never service equipment while it is operating. Keep hands, feet, and clothing away from moving parts
- Keep your equipment in proper working condition. Replace worn or broken parts immediately.



ST-0003-1

### Operate Motor Properly

- All electrical connections must be made in accordance with applicable local codes (National Electrical Code for the US, Canadian Electric Code, or EN60204 along with applicable European Directives for Europe). Make sure equipment and bins are properly grounded.
- Lock-out power before resetting motor overloads.
- Do not repetitively stop and start the drive in order to free a plugged condition. Jogging the drive in this manner can damage the equipment and drive components.

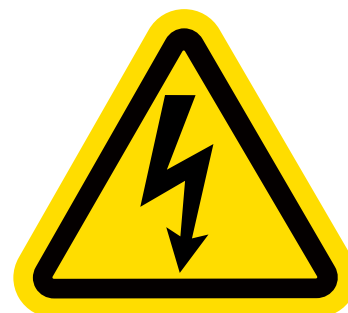

ST-0009-3

### Rotating Auger Hazard

- Keep clear of rotating augers and moving parts.
- Do not remove or modify guards or covers.
- Lock-out power source before making adjustments, cleaning, or maintaining equipment.
- Failure to follow these precautions will result in serious injury or death.



ST-0037-1

### Stay Clear of Hoisted Equipment

- Always use proper lifting or hoisting equipment when assembling or disassembling equipment.
- Do not walk or stand under hoisted equipment.
- Always use sturdy and stable supports when needed for installation. Not following these safety precautions creates the risk of falling equipment, which can crush personnel and cause serious injury or death.



ST-0047-1

## 1. Safety

### Stay Clear of Rotating Parts

- Do not enter the bin while the equipment is in operation.
- Entanglement in rotating augers will cause serious injury or death.
- Keep all guards and covers in place at all times.
- Lock-out power source before making adjustments, cleaning, or maintaining equipment.



ST-0008-2

### Use Unload Equipment Properly

- Do not operate this equipment alone. Make sure someone nearby is aware of the proper shut down sequence in the event of an emergency.
- Do not allow any person intoxicated or under the influence of drugs to operate this equipment. All operators must be adequately rested and prepared to perform all functions of operating the equipment.
- Do not start equipment until all persons are clear of the work area and safety guards are in place.
- Do not allow anyone inside a bin, truck, or wagon which is being unloaded by an auger. Flowing grain can trap and suffocate in seconds.
- Use ample overhead lighting after sunset to light the work area.
- Always use caution to not hit the auger when positioning the load.
- Do not leave equipment operating while unattended.
- Be aware of pinch points, which can trap or catch objects and cause injury.
- Be sure all equipment is locked in position before operating.
- Always lock out all power sources to the equipment when unloading is finished.



ST-0051-1







## 2. Decals

### Safety Decal Location

The types of decals and locations on the equipment are shown below. Good safety requires that you familiarize yourself with the various safety decals, the type of warning and the area or particular function that related to the area, that requires your SAFETY AWARENESS.

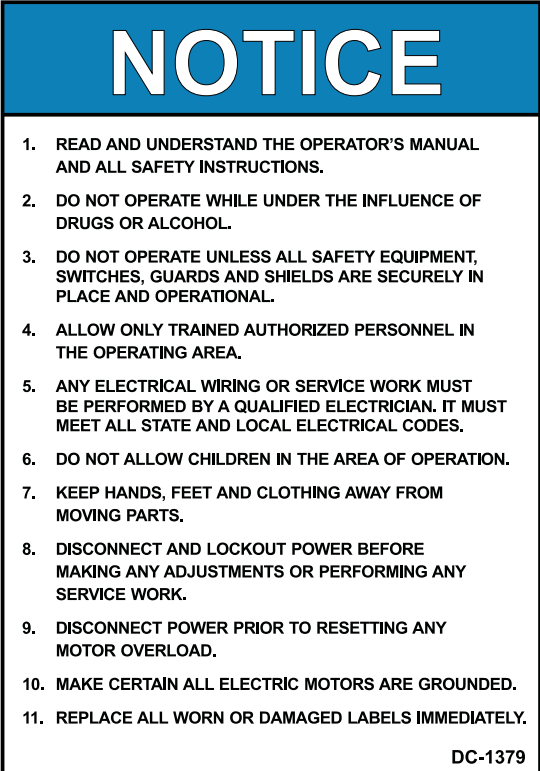
Decal #	Decals	Description
DC-994	 <p>GSI Group Inc. 217-226-4421 <span style="float: right;">DC-994</span></p>	Decal, Danger Shear Point
DC-995	 <p>GSI Group Inc. 217-226-4421 <span style="float: right;">DC-995</span></p>	Decal, Warning Shear Point
DC-1379	 <p style="text-align: center;"><b>NOTICE</b></p> <ol style="list-style-type: none"> <li>1. READ AND UNDERSTAND THE OPERATOR'S MANUAL AND ALL SAFETY INSTRUCTIONS.</li> <li>2. DO NOT OPERATE WHILE UNDER THE INFLUENCE OF DRUGS OR ALCOHOL.</li> <li>3. DO NOT OPERATE UNLESS ALL SAFETY EQUIPMENT, SWITCHES, GUARDS AND SHIELDS ARE SECURELY IN PLACE AND OPERATIONAL.</li> <li>4. ALLOW ONLY TRAINED AUTHORIZED PERSONNEL IN THE OPERATING AREA.</li> <li>5. ANY ELECTRICAL WIRING OR SERVICE WORK MUST BE PERFORMED BY A QUALIFIED ELECTRICIAN. IT MUST MEET ALL STATE AND LOCAL ELECTRICAL CODES.</li> <li>6. DO NOT ALLOW CHILDREN IN THE AREA OF OPERATION.</li> <li>7. KEEP HANDS, FEET AND CLOTHING AWAY FROM MOVING PARTS.</li> <li>8. DISCONNECT AND LOCKOUT POWER BEFORE MAKING ANY ADJUSTMENTS OR PERFORMING ANY SERVICE WORK.</li> <li>9. DISCONNECT POWER PRIOR TO RESETTING ANY MOTOR OVERLOAD.</li> <li>10. MAKE CERTAIN ALL ELECTRIC MOTORS ARE GROUNDED.</li> <li>11. REPLACE ALL WORN OR DAMAGED LABELS IMMEDIATELY.</li> </ol> <p style="text-align: right;">DC-1379</p>	Decal, Notice

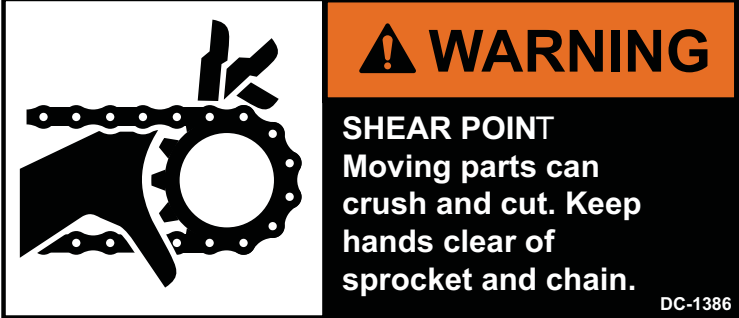
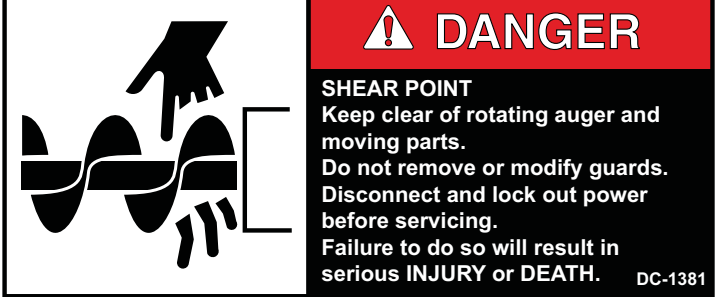
Decal #	Decals	Description
DC-1386	 <p><b>⚠ WARNING</b></p> <p><b>SHEAR POINT</b> Moving parts can crush and cut. Keep hands clear of sprocket and chain.</p> <p>DC-1386</p>	Decal, Chain Warning
DC-1381	 <p><b>⚠ DANGER</b></p> <p><b>SHEAR POINT</b> Keep clear of rotating auger and moving parts. Do not remove or modify guards. Disconnect and lock out power before servicing. Failure to do so will result in serious INJURY or DEATH.</p> <p>DC-1381</p>	Decal, Auger Danger

## U-Trough Unload Components

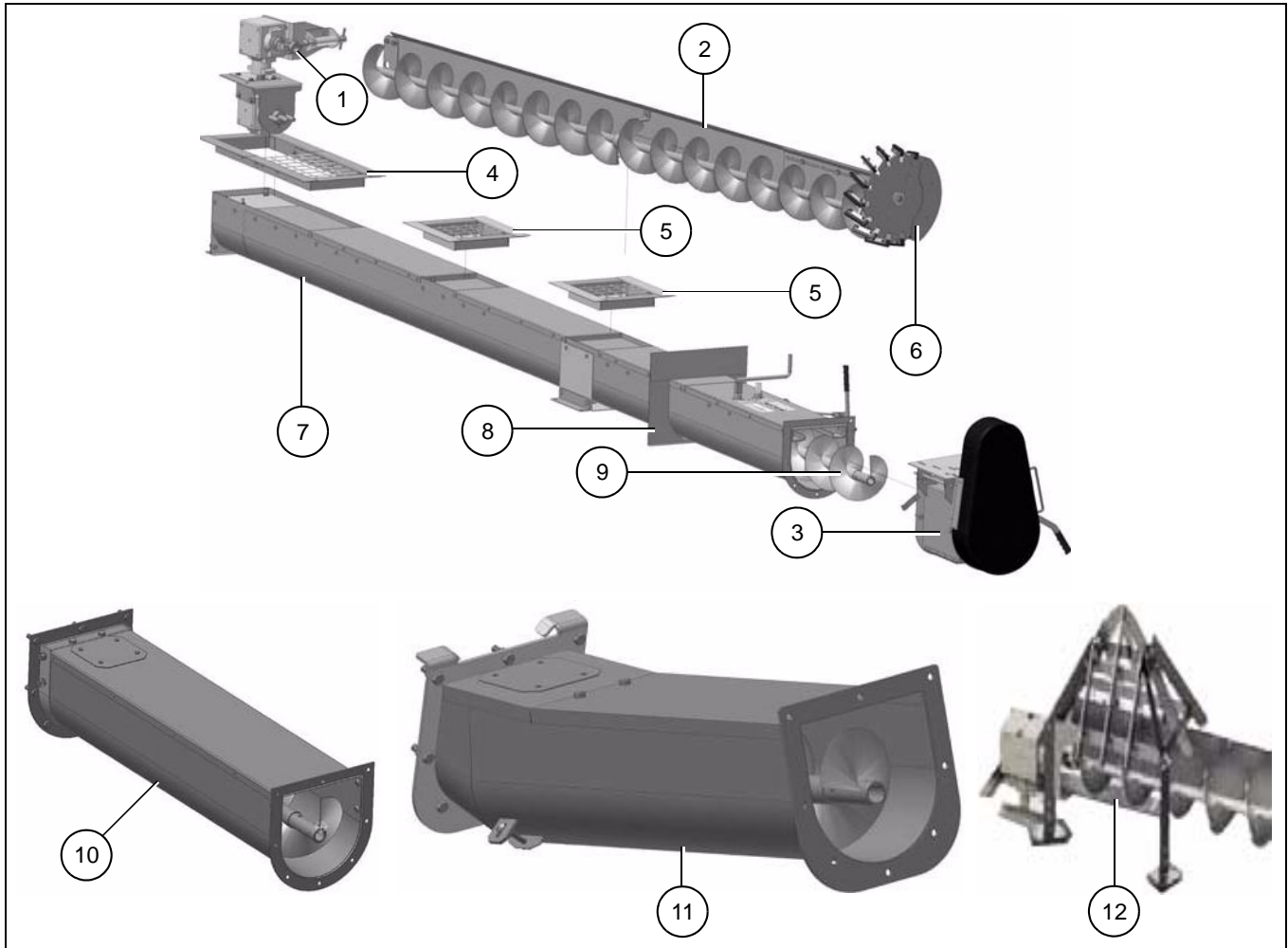

Figure 3A

Ref #	Description
1	Gearbox
2	Sweep
3	Drive Unit
4	Center Floor Flange
5	Intermediate Floor Flange
6	Elevator Drive Wheel
7	Trough
8	Bin Plate
9	Unload Flight

Optional Equipment	
Ref #	Description
10	U-Trough Extension
11	Incline Elbow
12	Grain Flow Maintainer

## Installation Under Aeration Floor

1. Cut 12" x 12" (30 cm x 30 cm) opening in bin wall where unload is to exit bin. (See Figure 4A.)



***Do not cut across bolted seams.***

2. Insert unload and center it in the bin.
3. Secure unload with anchor bolts (not supplied) to the bin foundation.

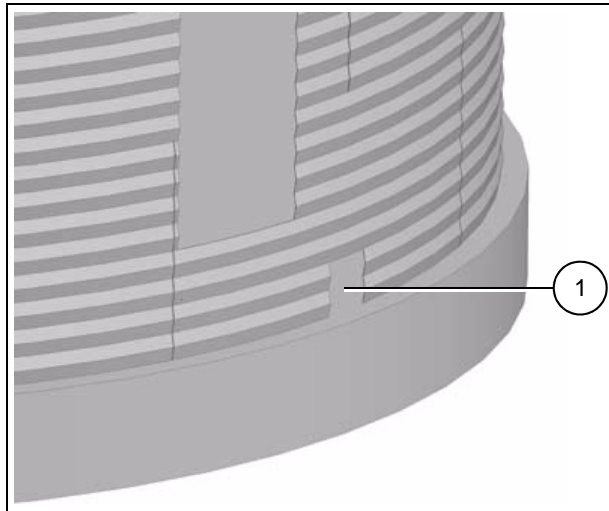

**Figure 4A**

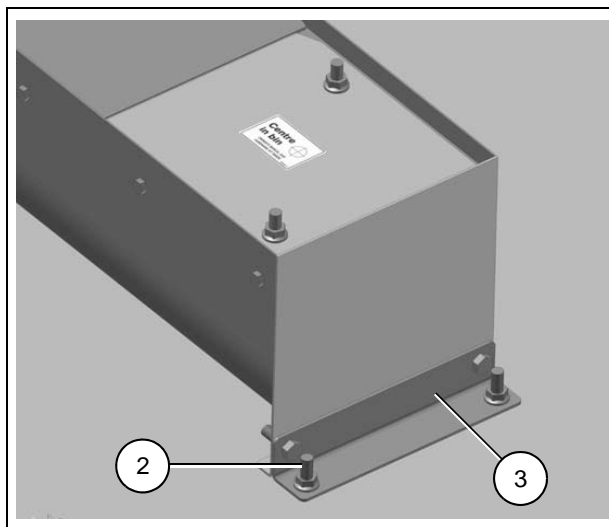

**Figure 4B**

Ref #	Description
1	Cut 12" x 12" access through bin wall.
2	Concrete Anchor Bolt
3	U-Trough unload. Center in bin and anchor to floor.

## 4. Installation

4. Layout aeration floor and cut opening around gates, approximately 1" larger than gate openings. (See [Figure 4C.](#))
5. Attach floor flanges to floor with self-drilling screws. (See [Figure 4E.](#))
6. Ensure that there is a minimum of 1/4" clearance between the bottom edge of the floor flange and the slide gate.



Figure 4C



Figure 4E

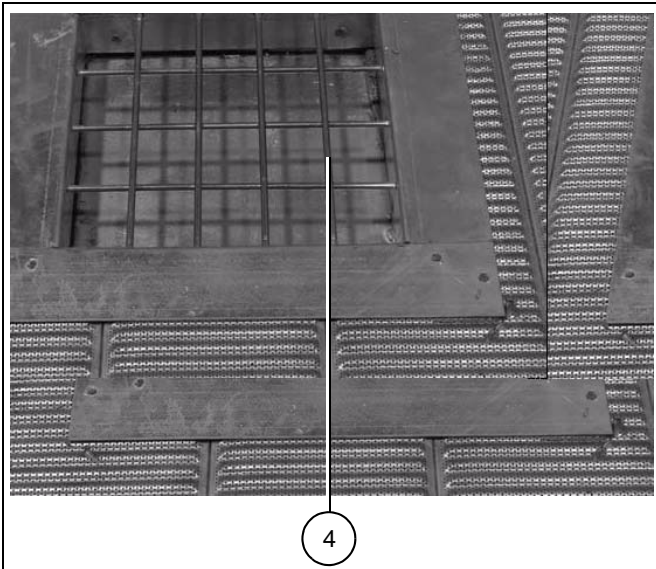

Figure 4D

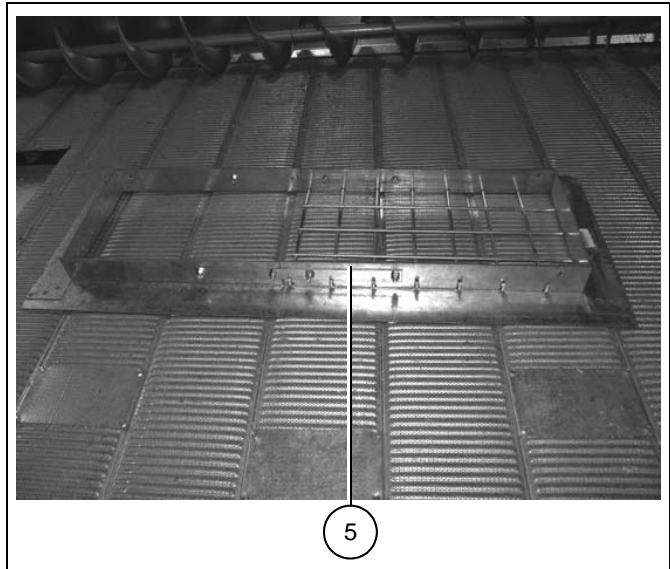

Figure 4F

Ref #	Description
4	Ensure clearance between bottom of floor flange and gate. If the clearance is larger than 1/4" (6.5 mm) additional sealing may be required. Clearance can not exceed 5/8" (16 mm). (Refer to <a href="#">Page 42</a> for dimensional view.)
5	U-Trough center floor flange comes in two parts. Before installing bolt together with joiner strips provided.

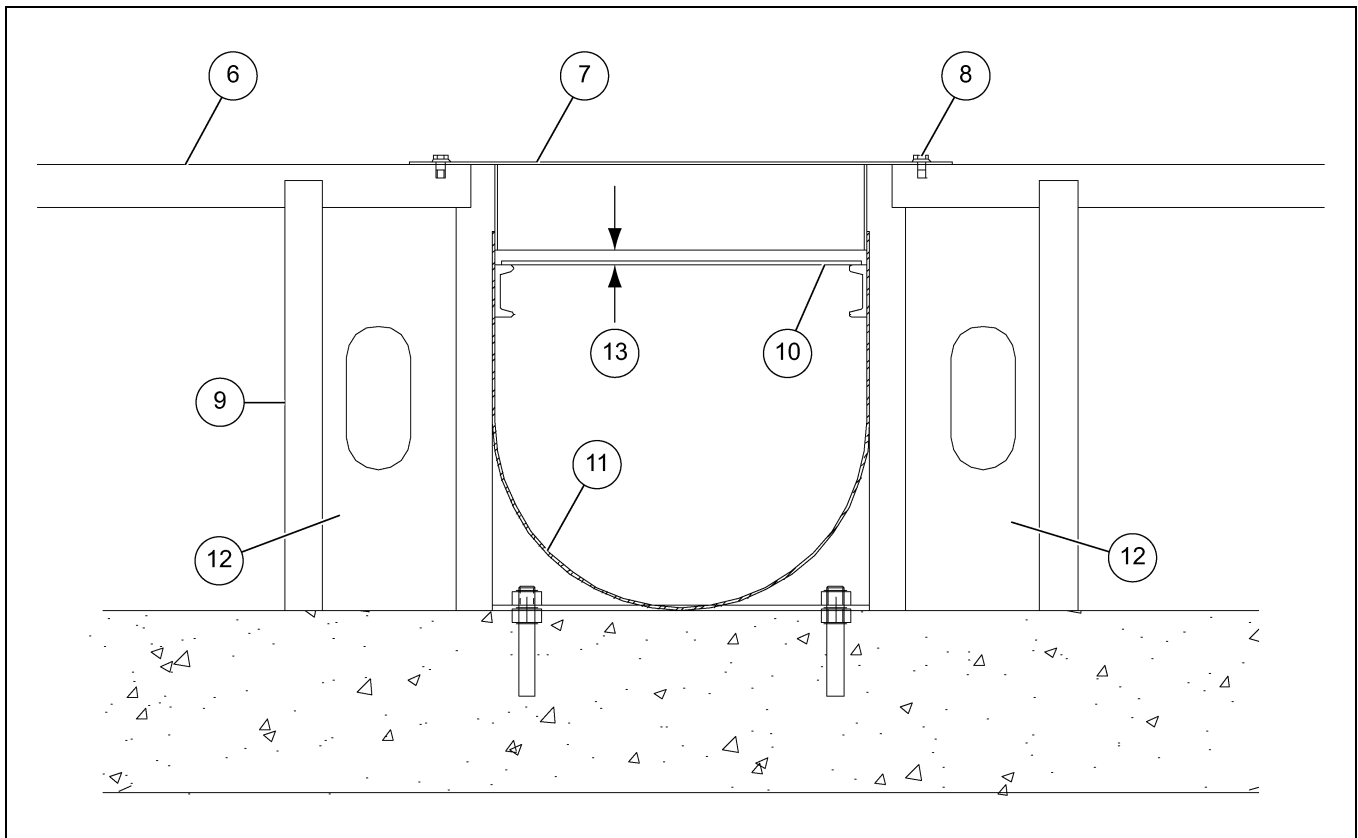

Figure 4G U-Trough Unload

Ref #	Description
6	Aeration Floor Plank
7	Floor Flange
8	Self-Drilling Screw
9	Aeration Floor Support

Ref #	Description
10	Gate
11	U-Trough
12	Place aeration supports close to unload.
13	1/4" Minimum

## 4. Installation

7. Install bin wall flange as shown in *Figure 4H* and *Figure 4I*.

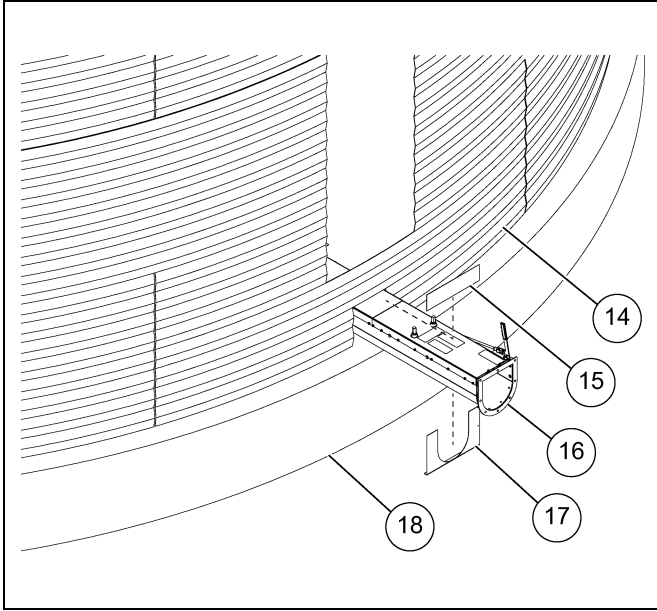

Figure 4H

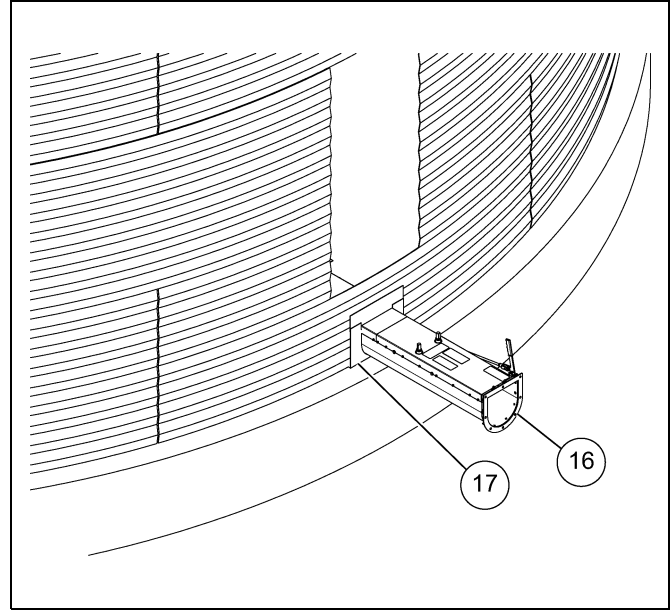

Figure 4I

Ref #	Description
14	Bin Wall
15	Bin Wall Flange - Upper
16	U-Trough Unloader
17	Bin Wall Flange - Lower
18	Bin Foundation

**NOTE:** Concrete must be level where the unload is positioned. Failure to do so can cause distortion the U-Trough when unit is anchored down. This distortion is likely to cause excessive operational noise from incorrect flight clearance.



## Installation in Concrete Foundation

### Concrete Knock-Out

1. When constructing the concrete foundation, form a knock-out for the unload as shown in [Figure 4J](#). This is the preferred method of installing the unload in concrete. When installed in this manner unloads can be removed at a later date.
  - a. Center the unload in the bin foundation.
  - b. Anchor to the bottom of the knock-out with concrete anchor bolts (not provided).
  - c. Install floor flanges over the gates.
  - d. Use wood or metal planking to cover exposed unload between gates.

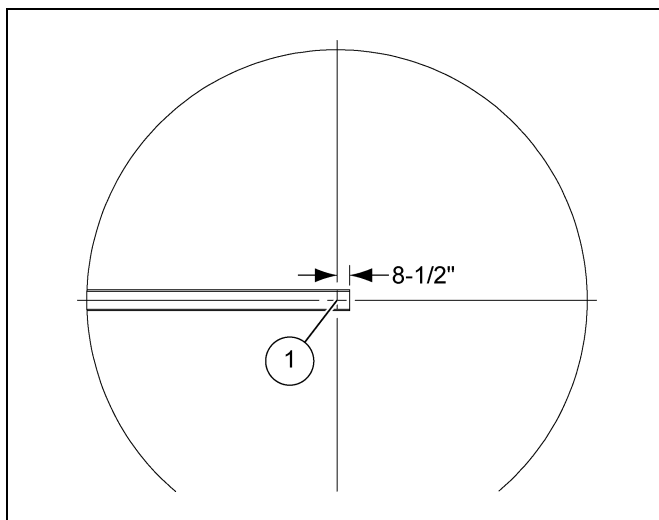

Figure 4J

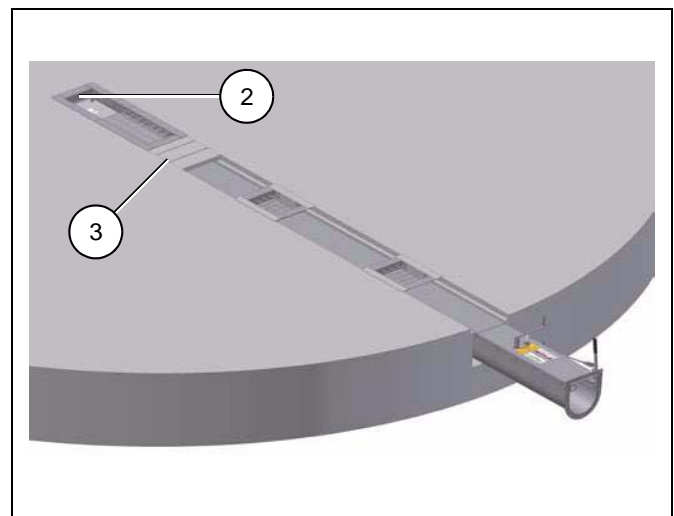

Figure 4L

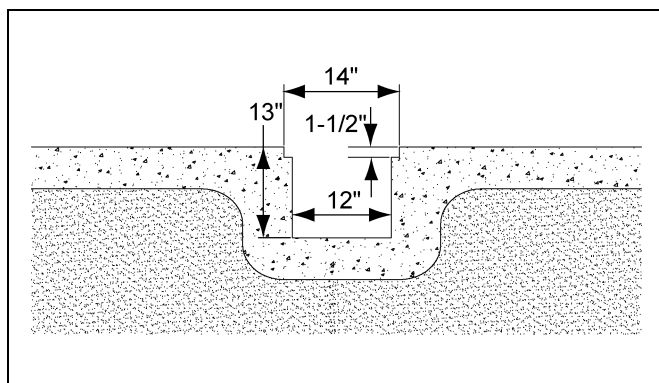

Figure 4K

Ref #	Description
1	Center of Bin Foundation
2	Center in Bin
3	Planking

## 4. Installation

### Unload Cast Directly into Concrete

When casting unloads directly into concrete, center in the bin and adjust the height as shown in [Figure 4M](#). Use floor flanges to form around the gate openings.

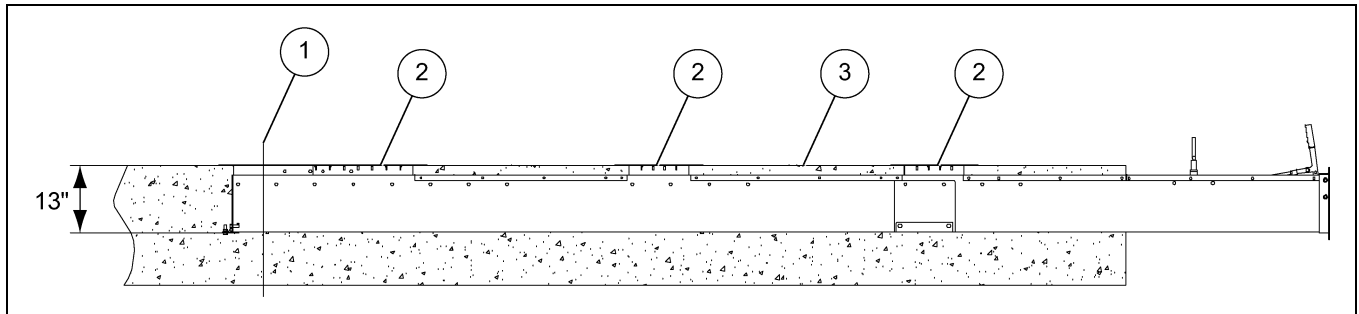
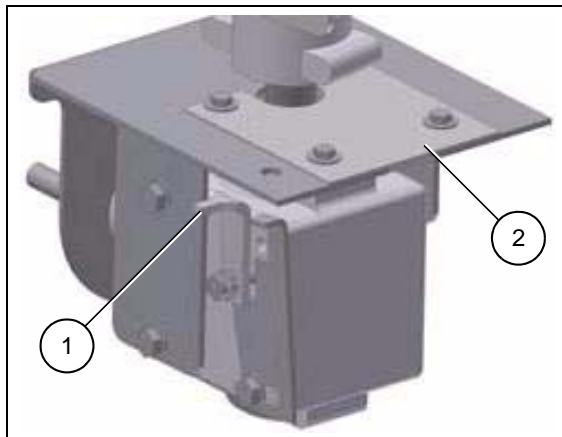

**Figure 4M** U-Trough Unload in Concrete

Ref #	Description
1	Center of Foundation
2	Floor Flanges
3	Install concrete reinforcing mesh above unload.

### Sweep Drive

Install gearbox into unload. Ensure that the shifter arm on the gearbox slides into the shifter slot on the unload. Secure gearbox with two (2) flange nuts. ([See Figures 4N and 4O](#).)



**Figure 4N**

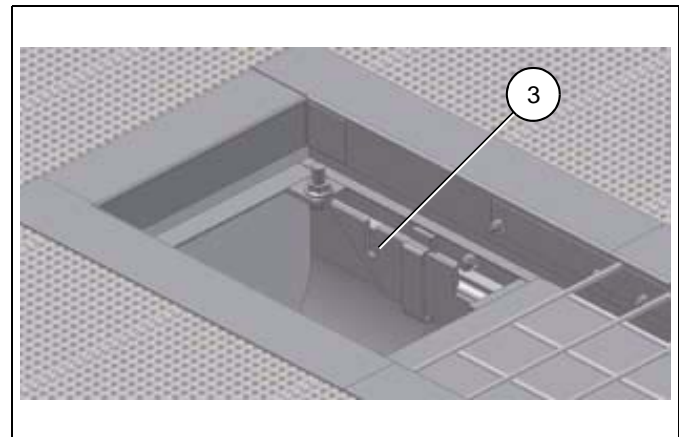

**Figure 4O**

Ref #	Description
1	Shifter Arm
2	Cover plate can be removed to access lower gearbox area.
3	Slot

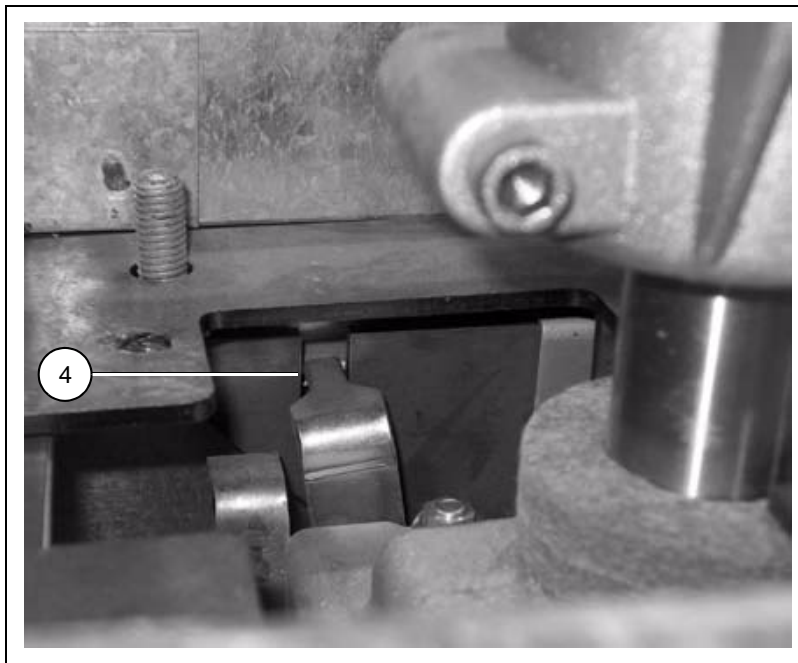

Figure 4P

Ref #	Description
4	Gearbox Shifter Arm in Shifter Slot

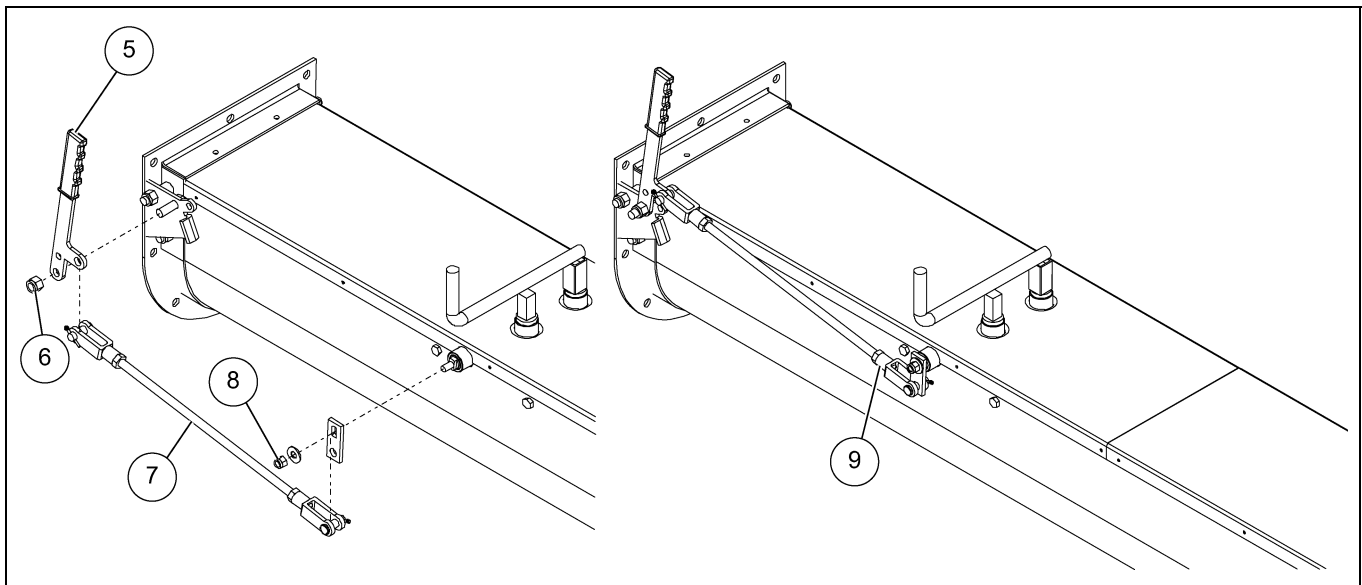

Figure 4Q

Ref #	Description
5	Shifter Handle
6	1/2" Lock Nut
7	Shifter Linkage

Ref #	Description
8	3/8" Lock Nut
9	U-Trough unload gearbox shifter handle installation.

## 4. Installation

1. Adjust gearbox shifter linkage such that when shifting into OFF position, there is some resistance when the lever overcenters into the OFF position.
2. Do not over tighten as this can damage the gearbox.
3. Before operating ensure that the gearbox is shifting properly.
4. Shift into OFF, turn unload flight by hand. (See Figure 4S.)
5. The top gearbox should not be turning.
6. Shift into ON position, top gearbox should turn when unload flight is turned. (See Figure 4R.)



**Figure 4R** Gearbox Shifter in ON Position

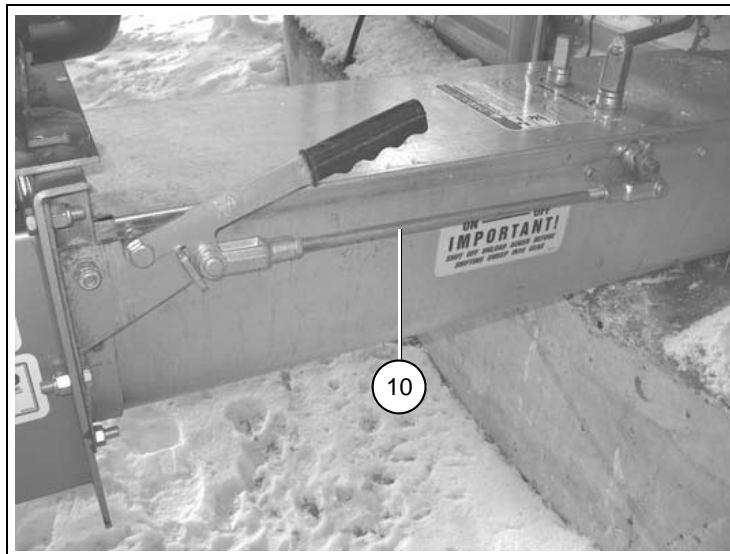

**Figure 4S** Gearbox Shifter in OFF Position

Ref #	Description
10	Adjust Shifter Linkage

## Sweep Arm

### Adjustments

1. Attach sweep to sweep gearbox drive.
2. To adjust overall sweep length, slack off four mounting bolts holding adjuster plate to sweep and slide in or out to set length. (See Figure 4T.)
3. The height of the sweep back plate can be adjusted both at the wheel and at the drive end. (See Figures 4U and 4V.)
4. The sweep back plate can be adjusted in and out at the center gearbox assembly to achieve desired sweep flight to sweep back plate spacing. (See Figure 4W.)

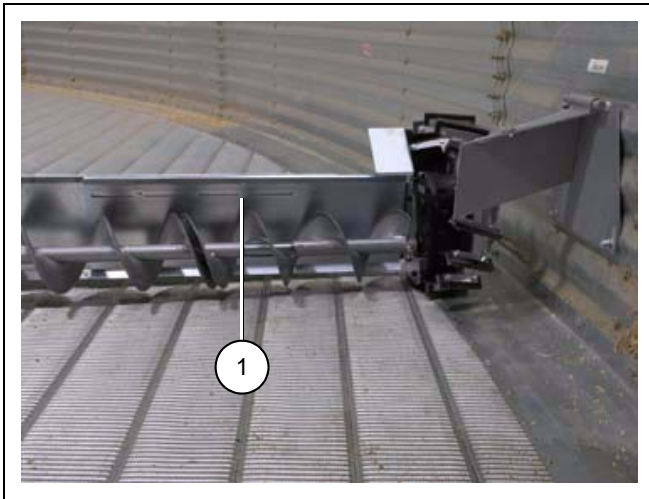

Figure 4T

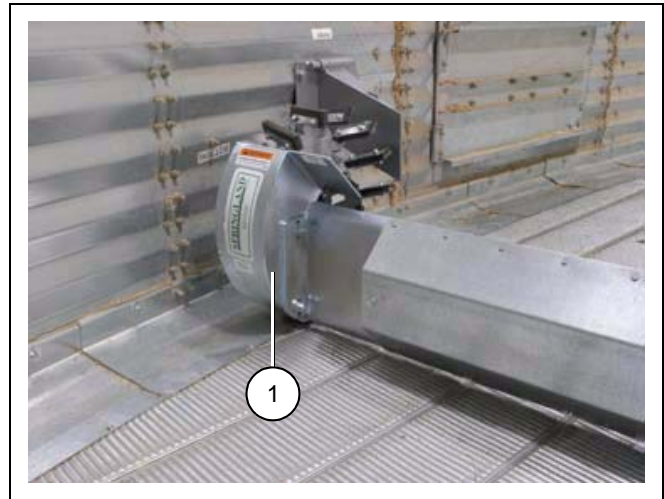

Figure 4V

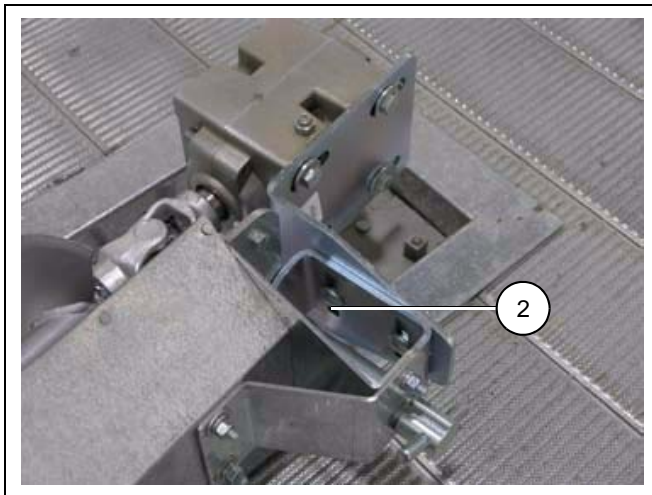

Figure 4U

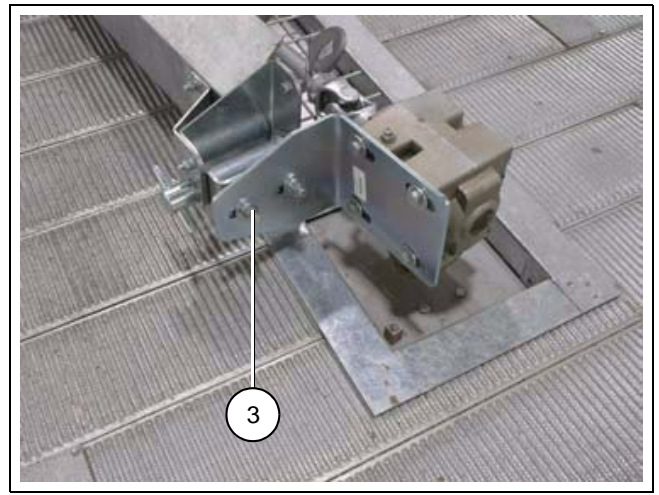

Figure 4W

Ref #	Description
1	Length Adjustment
2	Height Adjustment
3	Side Adjustment



## 4. Installation

### Two (2) Section Bin Sweeps (54'-75' Diameter)

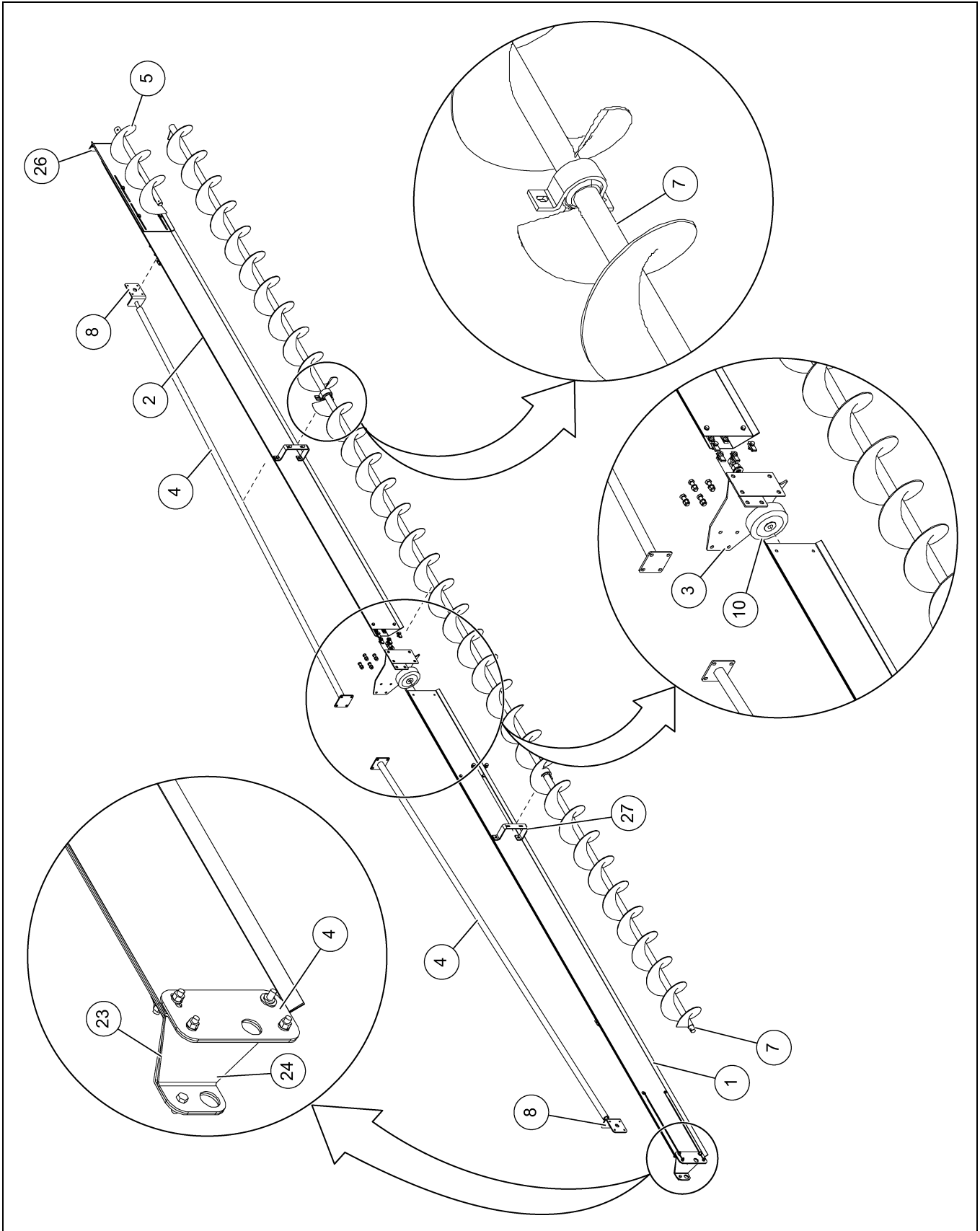

Figure 4X

## Two (2) Section Bin Sweeps (54'-75' Diameter) Parts List

Ref #	Description	Qty
1	Sweep Back Plate 60' (Inner)	1
2	Sweep Back Plate 60' (Outer)	1
3	Back Plate Joiner	1
4	Sweep Brace	2
5	Sweep Wheel Flight 9"	1
6	1-1/2" Split PB Assembly	2
7	Sweep Flight 9"	1
8	Sweep Brace Mount	2
9	Hex Nut Grade 5 UNC 3/4"	6
10	6" Wheel with 3/4" Bearing	1
11	Flat Washer 3/4" Plated	6
12	Bolt, Grade 5 UNC Plated 3/4" x 5"	1
13	U-Nut 3/8"	8
14	Bolt, Grade 5 UNC Plated 1/2" x 1-1/2"	4
15	Lock Washer 1/2" Plated	4
16	Hex Nut Grade 5 UNC 1/2"	4
17	Flat Washer 3/8" Plated	10
18	Lock Washer 3/8" Plated	33
19	Bolt, Grade 5 UNC Plated 3/8" x 1-1/2"	2
20	Hex Nut Grade 5 UNC 3/8"	11
21	Carriage Bolt UNC Plated 3/8" x 1"	8
22	Sweep Center Plate Joiner	1
23	Sweep Center Mount Inner Plate	1
24	Sweep Center Mount	1
25	Bolt, Grade 5 UNC Plated 3/8" x 1"	23
26	Sweep End Adjuster Plate	1
27	Sweep PB Mount 9"	2
28	Lock Washer 3/4" Plated	3

## 4. Installation

### Sweep Drive Wheel

#### Elevator Drive Wheel

To adjust the elevator wheel, loosen the top nut and move into position, then re-tighten hardware.

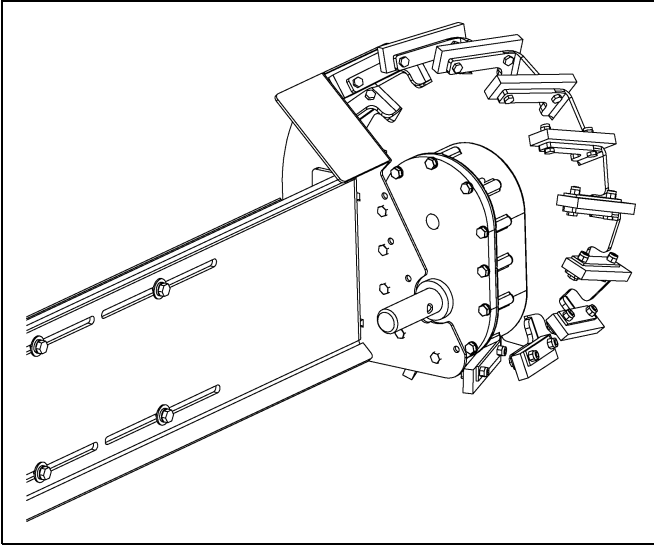

**Figure 4Y** Mounted for 7-1/4" Flight Position

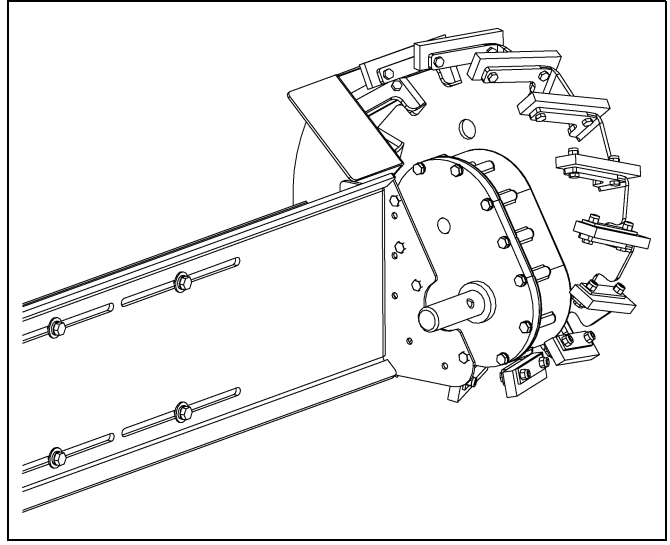

**Figure 4Z** Mounted for 8-1/4" and 9" Flight Position

### Sweep Stop

Mount sweep stop such that it will stop the sweep before it reaches the walk through door.



**Figure 4AA**

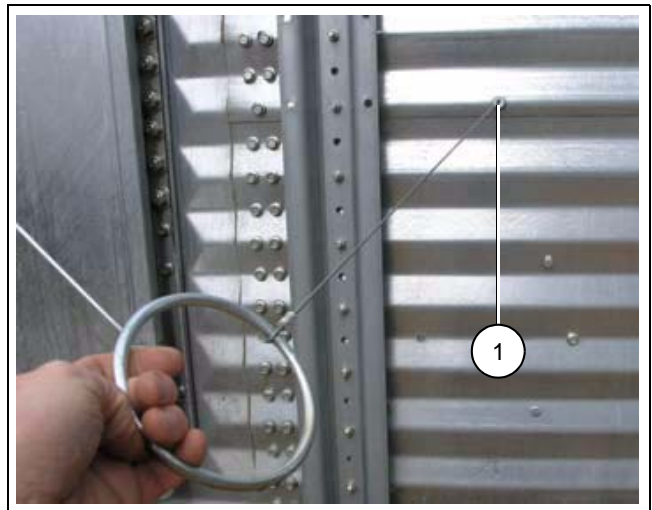

**Figure 4AB**

Ref #	Description
1	Install bolt containing a through hole at height shown. Feed cable through hole and reconnect to sweep stop.



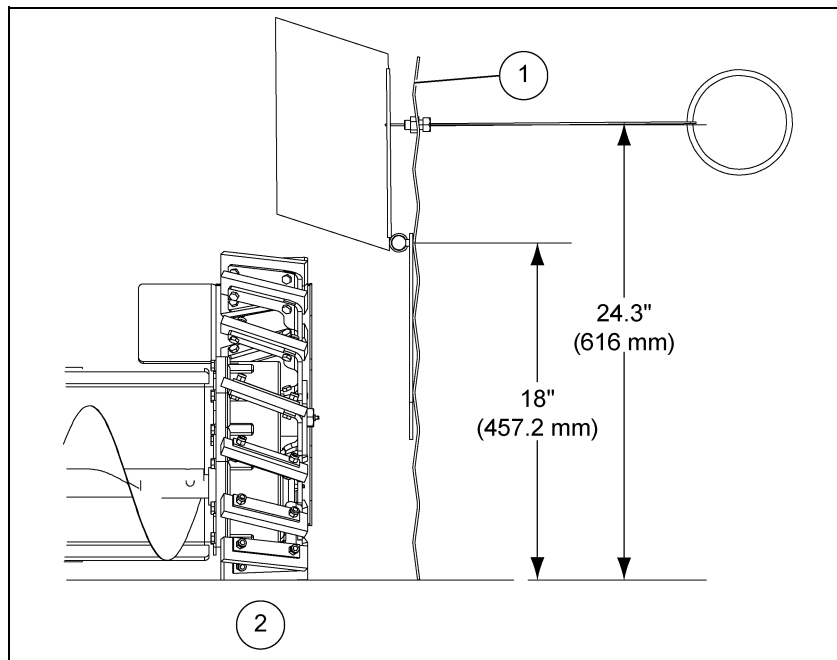

Figure 4AC

Ref #	Description
1	Install bolt containing a through hole at height shown. Feed cable through hole and reconnect to sweep stop.
2	Height of sweep stop with elevator drive wheel.

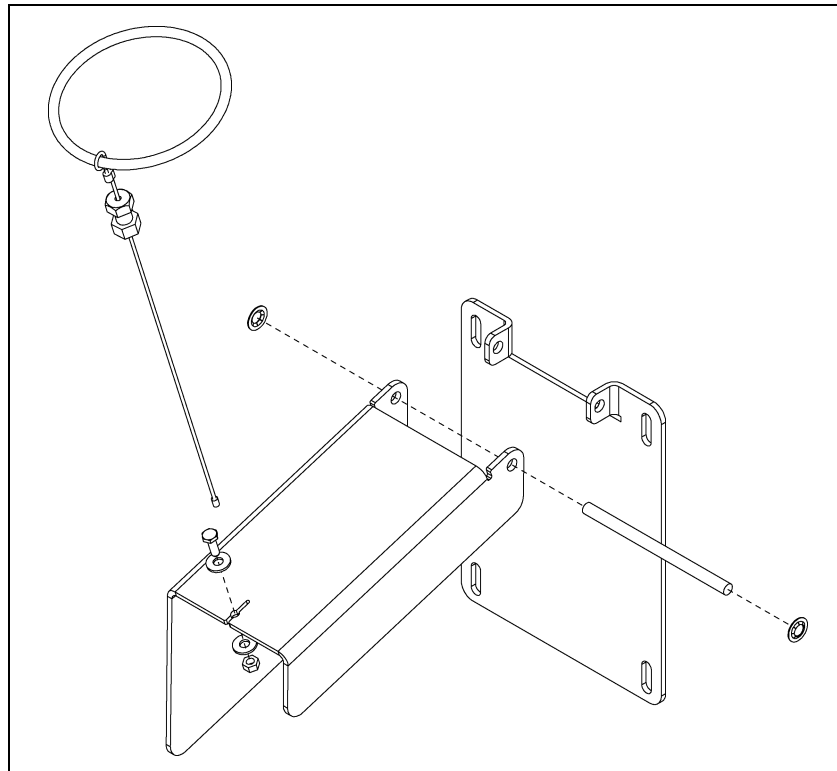

Figure 4AD

**ONLY OPERATE SWEEP STOP FROM OUTSIDE THE BIN.**

## 4. Installation

### Horizontal Drive Unit

1. Attach drive unit to unload.
2. Attach drive shaft and bearing.
3. Lock bearing to shaft with eccentric locking collar. The eccentric locking collar is locked to the shaft with a punch and hammer (turn the collar clockwise to tighten) as well as with a locking set screw.
4. Note the flight rotation when installing and wiring the drive motor. Correct rotation is clockwise when looking at the drive unit.
5. Adjust belt tension with clevis on overcenter tensioner. (*See Figure 4AE.*)



Figure 4AE

Ref #	Description
1	Flight Rotation
2	Bearing Locking Collar

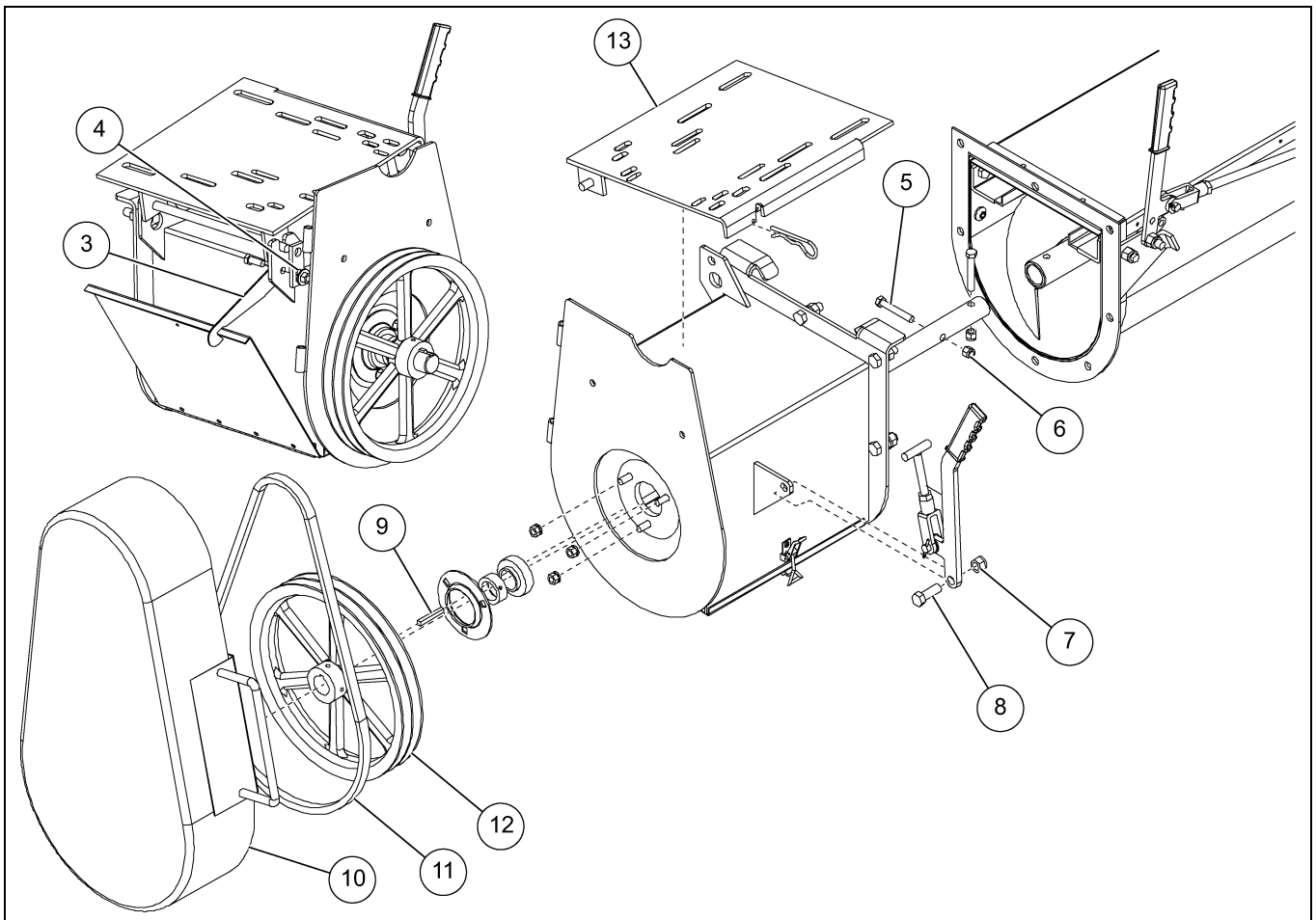

Figure 4AF

Ref #	Description
3	Door Catch
4	Motor Mount Lock
5	3/8" x 2-1/2" Grade 8 Bolt
6	3/8" Lock Nut
7	1/2" Lock Nut
8	1/2" x 1-1/2" Bolt
9	1/4" Key
10	Poly Shield
11	V-Belt
12	Pulley
13	Motor Plate

## 4. Installation

### Taper Bore Hub Installation

1. Be sure the tapered cone surfaces of the bushing and inside of pulley are clean and free of grease and oil.
2. Place bushing in pulley.
3. Place bolts and lock washers loosely in pull-up holes. Bushing remains fully expanded to assure sliding fit on shaft.
4. With key on shaft slide pulley to desired position on shaft. Be sure heads of bolts are on outside.
5. Tighten bolts alternately and progressively until they are pulled up tight. Tighten to 180 in. lbs. (20 N-m) torque. Do not allow pulley to be drawn in contact with flange of bushing. There should be a gap from 1/8" to 1/4". (See Figure 4AG.)

**DO NOT OVER-TIGHTEN.**

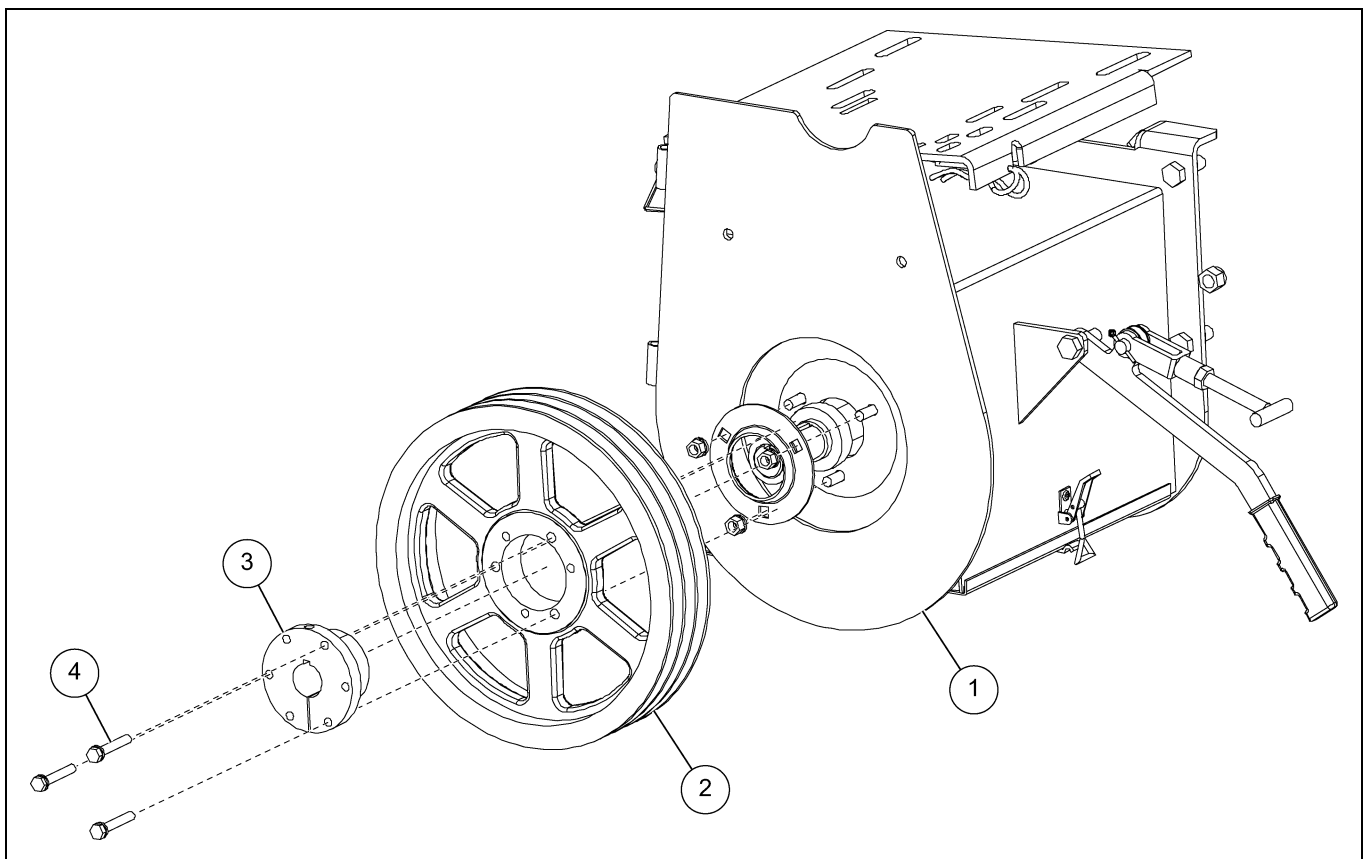

Figure 4AG

Ref #	Description
1	Drive Unit
2	Pulley
3	Bushing
4	Bolt

## Incline Elbow

1. Attach the incline elbow shaft (hex round) to the unload flight.
2. Attach the incline elbow to the unload.
3. When installing the drive unit on the inline elbow ensure that the flight is adjusted so that the support bearing is centered in the flight gap. Slide the incline elbow flight up or down to set this adjustment. When incline elbows are used with heavy motors it is recommended to provide support back to the bin with cables (not provided). Support mount clips are provided. *(See Figures 4AH below and 4AI on Page 30.)*

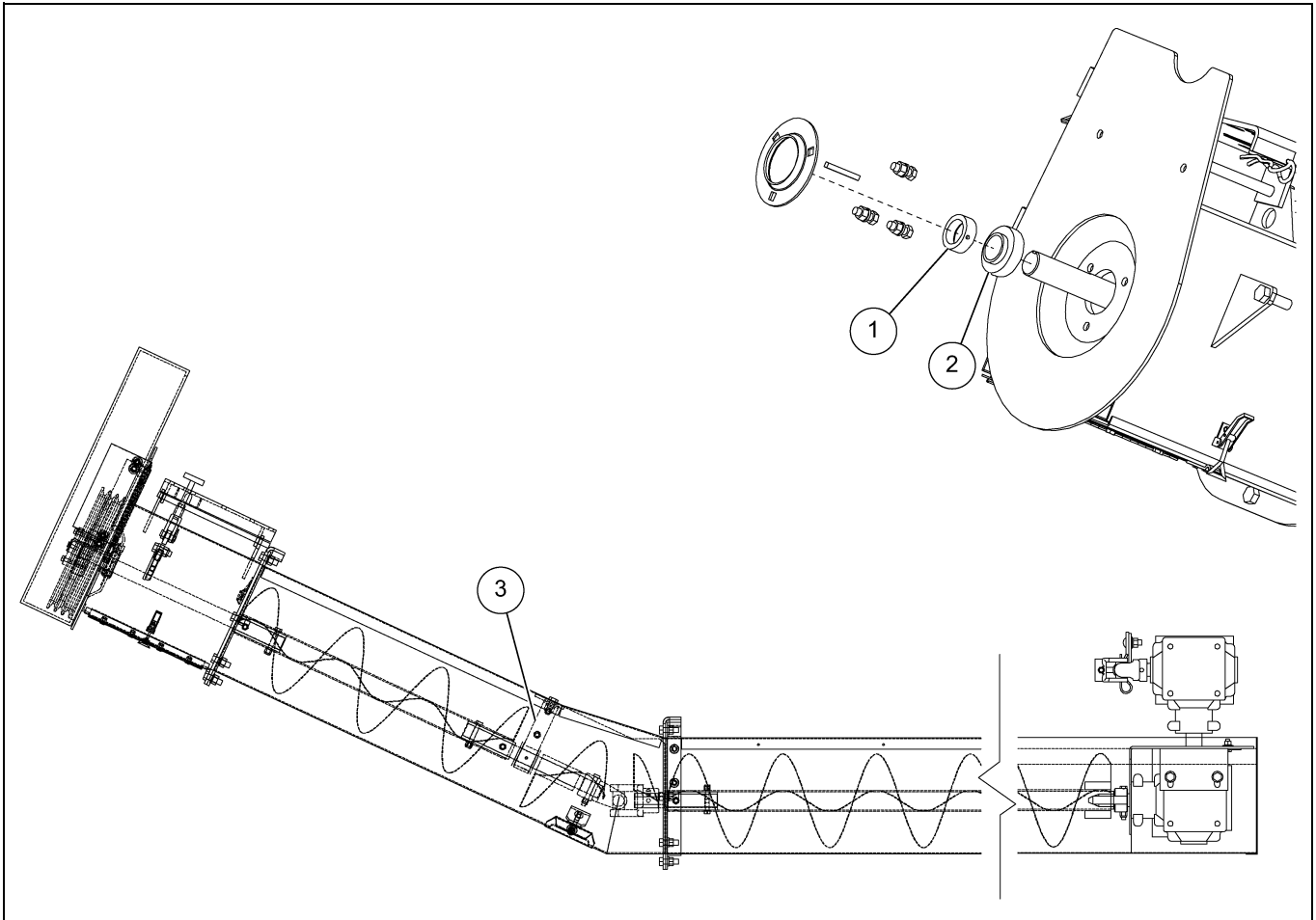

Figure 4AH

Ref #	Description
1	Locking Collar
2	Bearing
3	Support Bearing

## 4. Installation

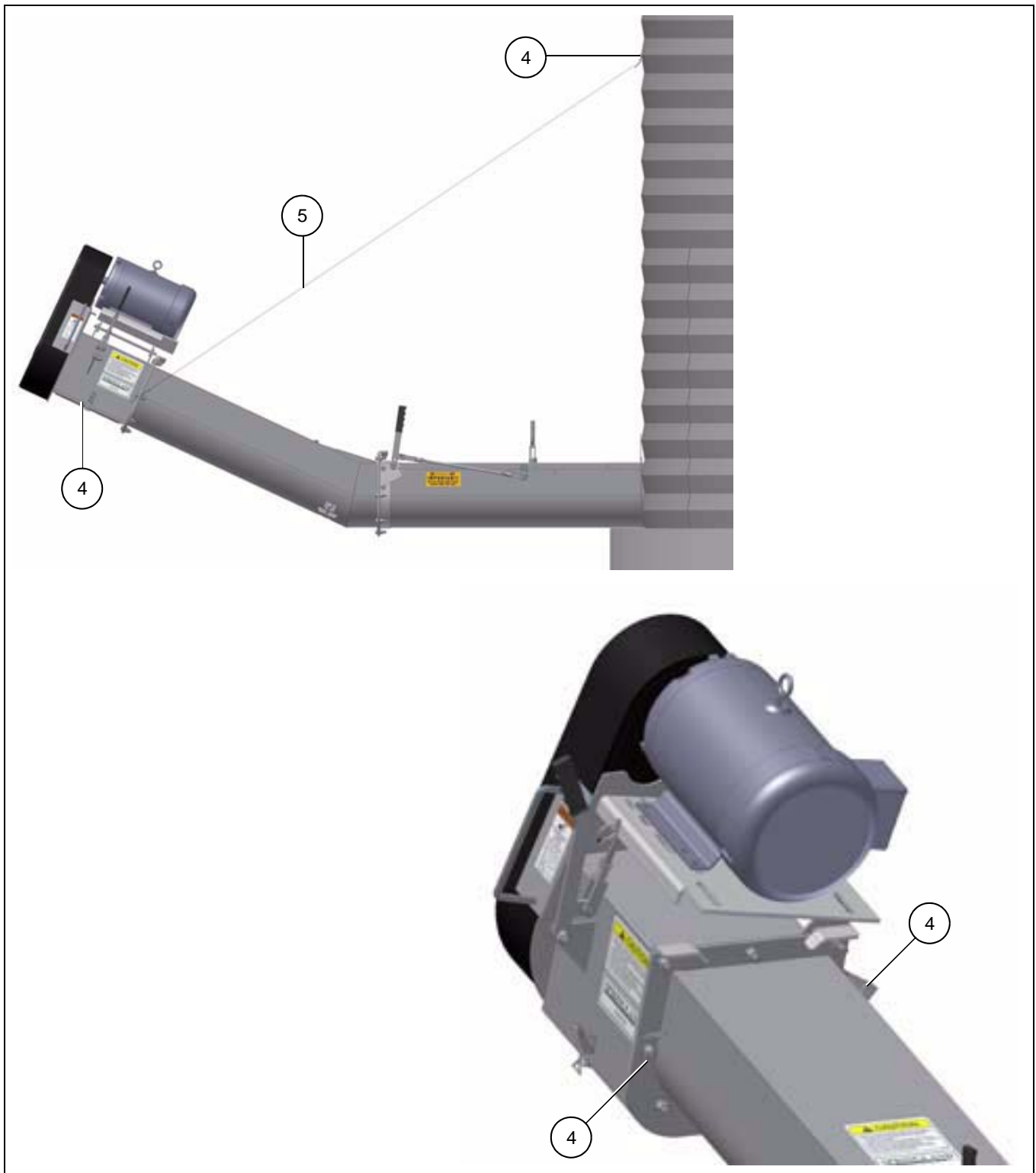

Figure 4AI

Ref #	Description
4	Support Mount Clip
5	Support Cable

Power requirements are dependent on grain type, condition and moisture level. Power requirements are suggestions and may vary in specific circumstances. Steps can be taken to reduce the power needed to operate the unload or sweep if power available to the site is limited. Operating the unload at a slower speed and reducing the flow of grain into the unload will reduce power requirement.

### Electric Drive

All values in horsepower, (1 HP = 0.746 Kw).

A pulley for the electric drive motor is not provided.

For 1750 RPM motor use 3-1/2" - 3-3/4" diameter pulley, for 1460 RPM motor use 4-1/4" - 4-1/2" diameter pulley.

For power requirements from 1.5 HP - 7.5 HP use a two (2) groove pulley.

For power requirements from 10 HP - 25 HP use a three (3) groove pulley.

#### U-Trough Unloader with Sweep - Horizontal Powerhead

Bin Diameter	7-1/4" Sweep		8-1/4" Sweep		9" Sweep	
	12.4" Flight Pulley	18.4" Flight Pulley	12.4" Flight Pulley	18.4" Flight Pulley	12.4" Flight Pulley	18.4" Flight Pulley
18'	5	3	5	3	7.5	5
19'	5	5	5	5	7.5	5
21'	5	5	5	5	7.5	5
24'	7.5	5	7.5	5	7.5	5
27'	7.5	5	7.5	5	7.5	5
30'	7.5	5	7.5	5	10	7.5
33'	7.5	5	7.5	5	10	7.5
36'	10	7.5	10	7.5	10	7.5
42'	10	10	10	10	15	10
48'	15	15	15	15	15	15
54'	N/A	15	N/A	15	N/A	20
60'	N/A	20	N/A	20	N/A	20
66'	N/A	20	N/A	20	N/A	25

## 5. Power Requirements

### U-Trough Unloader with Sweep - 25° Incline Elbow and Horizontal Powerhead

Bin Diameter	7-1/4" Sweep		8-1/4" Sweep		9" Sweep	
	12.4" Flight Pulley	18.4" Flight Pulley	12.4" Flight Pulley	18.4" Flight Pulley	12.4" Flight Pulley	18.4" Flight Pulley
18'	7.5	5	7.5	5	7.5	5
19'	7.5	5	7.5	5	7.5	5
21'	7.5	5	7.5	5	7.5	5
24'	7.5	5	7.5	5	10	7.5
27'	10	7.5	10	10	10	7.5
30'	10	7.5	10	10	10	7.5
33'	10	7.5	10	10	15	10
36'	10	7.5	10	10	15	10
42'	10	10	15	10	15	10
48'	15	15	15	15	20	15
54'	N/A	20	N/A	20	N/A	20
60'	N/A	20	N/A	25	N/A	20
66'	N/A	25	N/A	25	N/A	25

### Unload Individually

Bin Diameter	Unload with 12.4" Pulley Horizontal Drive Unit	Unload with 18.4" Pulley Horizontal Drive Unit	Unload with 12.4" Pulley Incline Drive Unit	Unload with 18.4" Pulley Incline Drive Unit
	9" Diameter	9" Diameter	9" Diameter	9" Diameter
15'	5	3	7.5	5
18'	5	3	7.5	5
19'	5	5	7.5	5
21'	5	5	7.5	5
24'	7.5	5	7.5	5
27'	7.5	5	10	7.5
30'	7.5	5	10	7.5
33'	7.5	5	10	7.5
36'	10	7.5	10	7.5
42'	10	7.5	15	7.5
48'	10	7.5	15	10
54'	15	7.5	15	10
60'	15	10	15	10



## Pulley Selection



**Capacity requirements must be determined prior to ordering any unload/sweep system. Failure to do so may cause the sweep to overfeed the center gate. This could cause the electric motor to cut out and may damage the sweep back plate.**

Listed on Pages 33-34 are the guidelines to assist with proper flight diameter and motor pulley selection. These are only theoretical values and will change with grain types, conditions and moisture content.

All capacities are shown in bushels per hour (BPH).

### 1750 RPM/60 Hz Motors

Below are charts outlining unload and sweep speeds and capacities when using a 1750 RPM motor. 1750 motor RPM is typically used in North America.

#### 12" Pulley

U-Trough Unloader with Sweep		
3.5" Motor Pulley and 12.4" Flight Pulley		
Motor	RPM	Capacity (Bushels Per Hour)
	1750	
Unload		500
Sweep	7.25"	335
	8.25"	
	9"	

U-Trough Unloader with Sweep		
4" Motor Pulley and 12.4" Flight Pulley		
Motor	RPM	Capacity (Bushels Per Hour)
	1750	
Unload		565
Sweep	7.25"	376
	8.25"	
	9"	

#### 18" Pulley

U-Trough Unloader with Sweep		
3.5" Motor Pulley and 18.4" Flight Pulley		
Motor	RPM	Capacity (Bushels Per Hour)
	1750	
Unload		333
Sweep	7.25"	222
	8.25"	
	9"	

U-Trough Unloader with Sweep		
4" Motor Pulley and 18.4" Flight Pulley		
Motor	RPM	Capacity (Bushels Per Hour)
	1750	
Unload		380
Sweep	7.25"	253
	8.25"	
	9"	

U-Trough Unloader with Sweep		
5" Motor Pulley and 18.4" Flight Pulley		
Motor	RPM	Capacity (Bushels Per Hour)
	1750	
Unload		475
Sweep	7.25"	316
	8.25"	
	9"	

## 5. Power Requirements

### 1460 RPM/50 Hz Motors

Below are charts outlining unload and sweep speeds and capacities when using a 1460 RPM motor. 1460 motor RPM is typically used in Europe.

#### 12" Pulley

U-Trough Unloader with Sweep			
4.25" Motor Pulley and 12.4" Flight Pulley			
Motor		RPM	Capacity (Bushels Per Hour)
		1460	
Unload		503	6000
Sweep	7.25"	335	2500
	8.25"		3500
	9"		4500

U-Trough Unloader with Sweep			
4.5" Motor Pulley and 12.4" Flight Pulley			
Motor		RPM	Capacity (Bushels Per Hour)
		1460	
Unload		531	6400
Sweep	7.25"	354	2700
	8.25"		3700
	9"		4800

#### 18" Pulley

U-Trough Unloader with Sweep			
4.25" Motor Pulley and 18.4" Flight Pulley			
Motor		RPM	Capacity (Bushels Per Hour)
		1460	
Unload		340	4000
Sweep	7.25"	226	1600
	8.25"		2300
	9"		3100

U-Trough Unloader with Sweep			
4.5" Motor Pulley and 18.4" Flight Pulley			
Motor		RPM	Capacity (Bushels Per Hour)
		1460	
Unload		356	4300
Sweep	7.25"	237	1700
	8.25"		2500
	9"		3400

### Capacity Chart

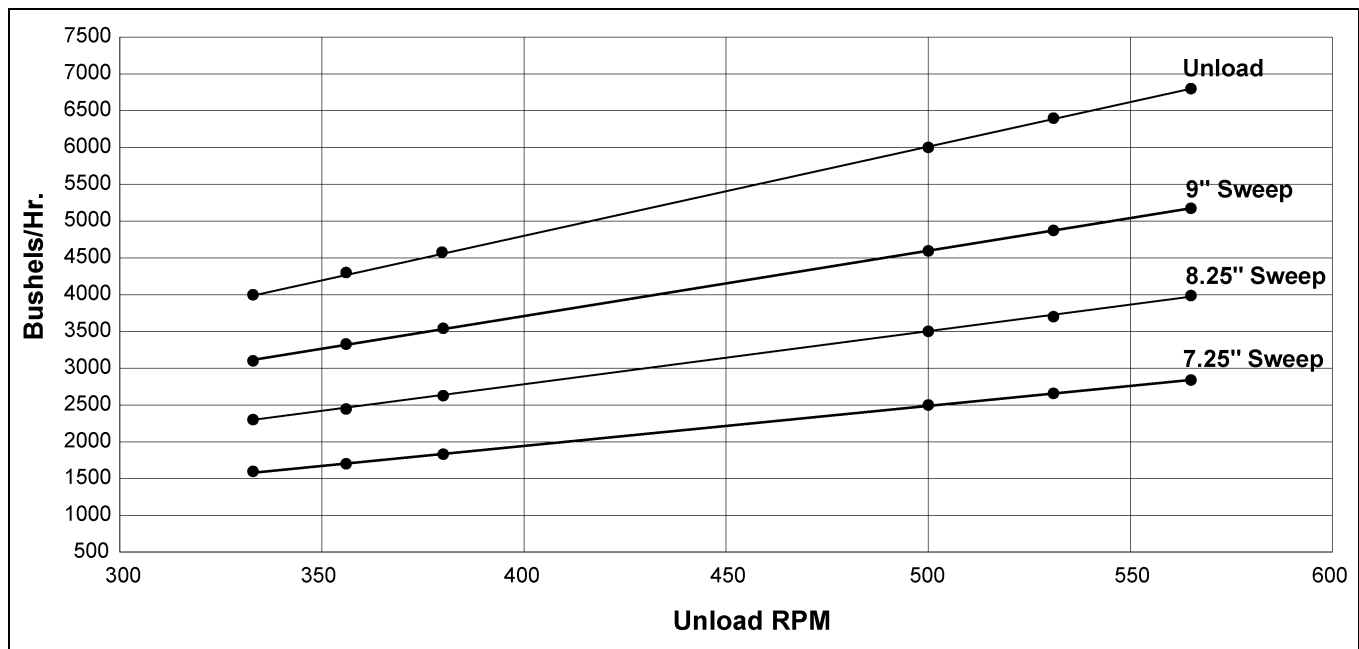

Figure 5A U-Trough Unload and Sweep Capacities

## Pre-Operation Check List

1. Before filling the grain bin, check to ensure that all unload components are functioning properly.
2. Rotate drive unit and flight to ensure flight is free of obstruction and rotating smoothly.
3. Open and closed all unload gates to ensure that they are operating freely.
4. LEAVE GATES IN THE CLOSED POSITION WHEN FILLING THE BIN.
5. Operate gearbox shifter to ensure the clutch is functioning properly.
6. GEARBOX SHOULD BE DISENGAGED WHEN FILLING THE BIN.
7. Position the bin sweep above the intermediate gates or such that the intermediate gates are just in front of the sweep.
8. After the bin is filled with product, keep moisture from entering the grain bin at the center and draining down into the unload and sweep drive area.
9. Before beginning to unload grain, check the grain condition at the top of the bin. Remove any clumps of grain as they may restrict flow into the gates.

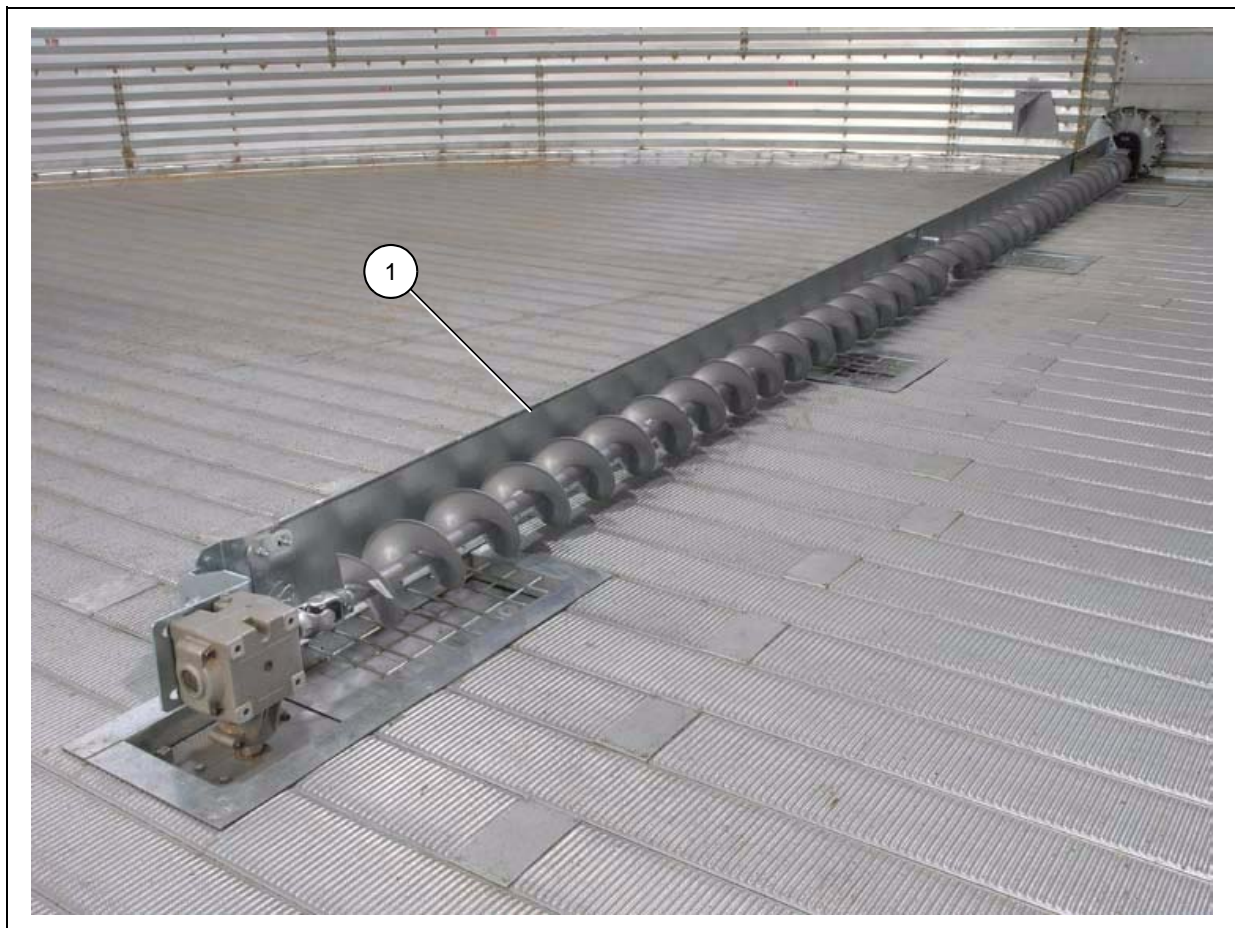

Figure 6A

Ref #	Description
1	Position sweep as shown before filling.

## 6. Operation



**ALWAYS UNLOAD FROM THE CENTER GATE FIRST. Unloading from the intermediate gates when the bin is still mostly full, causes excessive stress on the grain bin and can cause the grain bin to be damaged or collapse.**

For bin sizes 15'-36' the center gate is controlled independent of the intermediate gates. For bin sizes 42' diameter and larger the intermediate gate closest to the center gate is operated with the center gate control. When the center gate is 50% open, the next intermediate gate is opened together with the center gate such. Similarly, the center and next intermediate gate are closed together.

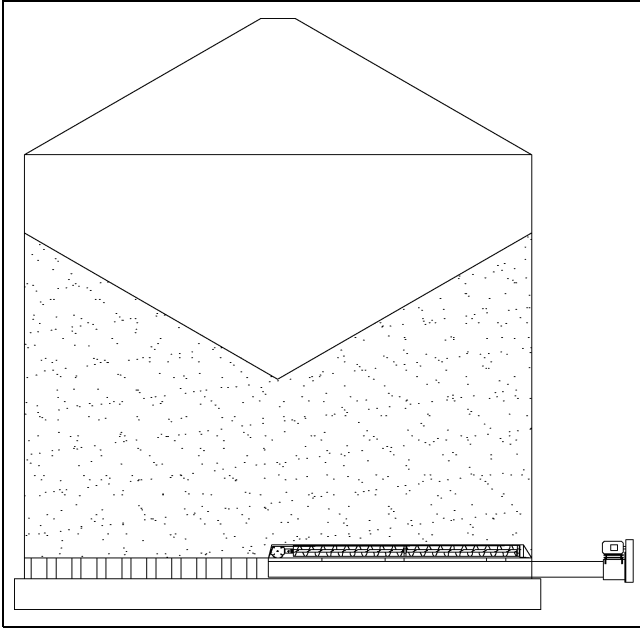

**Figure 6B** Center Unloading

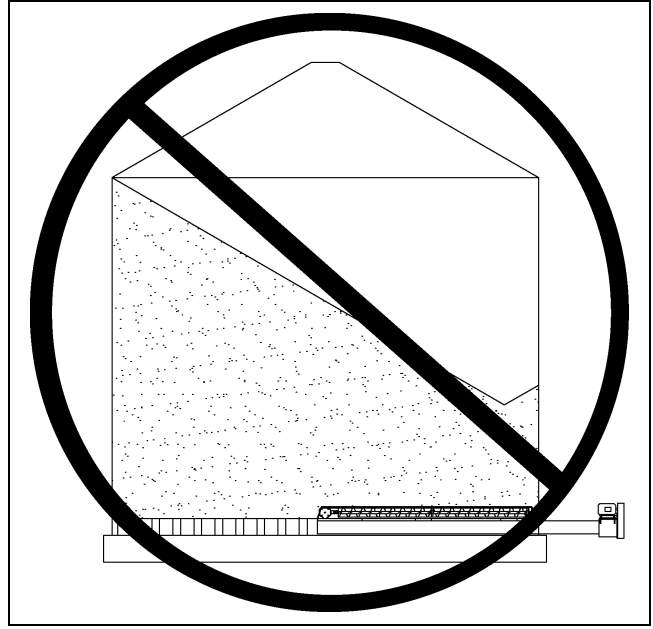

**Figure 6C** Off - Center Unloading

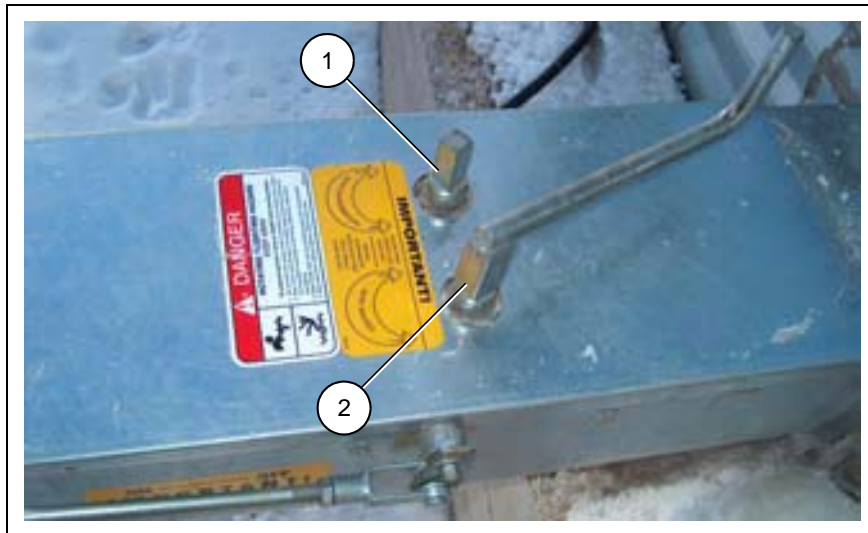

**Figure 6D**

Ref #	Description
1	Intermediate Gate Control
2	Center Gate Control

## Gearbox Sweep Operation

Turn OFF unload before shifting gearbox into gear. Ensure that the gearbox shifter has engaged before starting unload.



Figure 6E Gearbox OFF



Figure 6F Gearbox ON



## Gearbox Oil Level

(Check levels once per season or every 50 hours of operation.)

1. Fill top gearbox to side plug level.
2. Remove cover and fill bottom gearbox to line on dipstick.
3. Gearboxes are factory filled with USDA approved food grade oil ISO 150.
4. Oils such as SAE 80-90 gear oil are acceptable. Do not mix oil types.

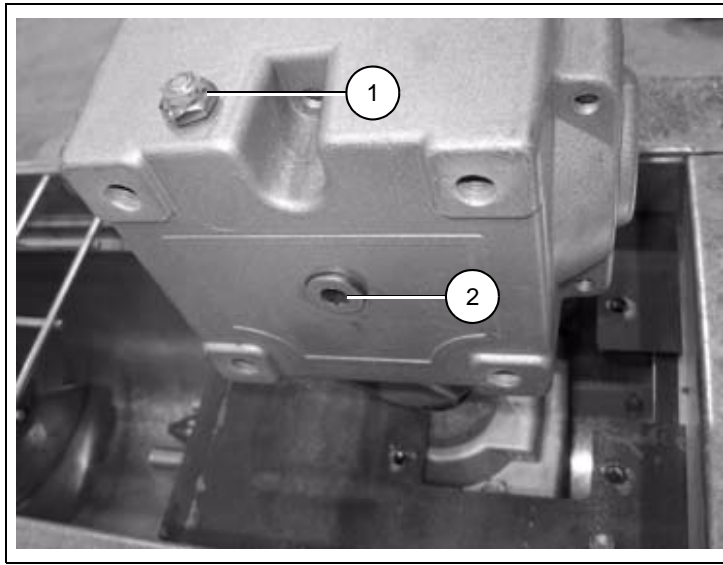

Figure 7A Top Gearbox

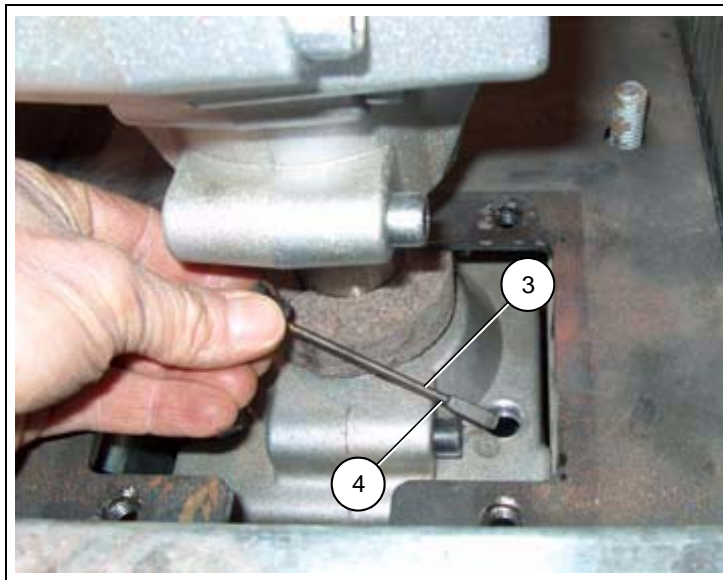

Figure 7B Bottom Gearbox

Ref #	Description
1	Vent Plug
2	Side Plug

Ref #	Description
3	Dipstick
4	Full Line

## Grease Points

(Grease every 8 hours of operation.)

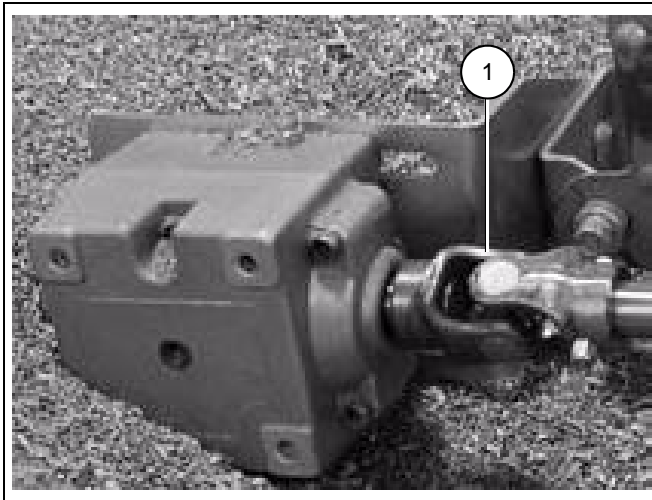

Figure 7C

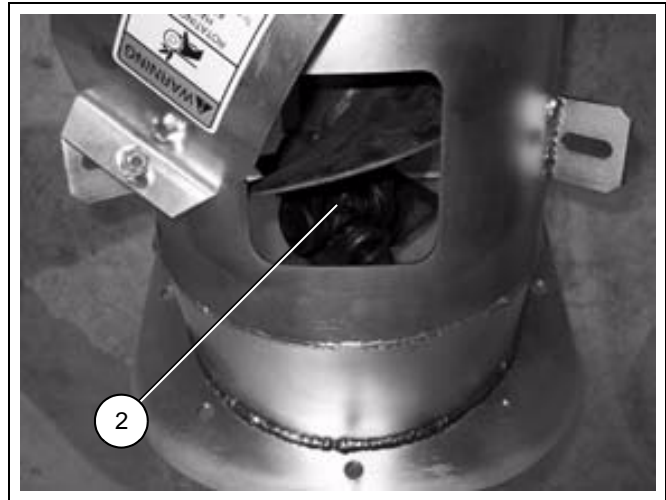

Figure 7D

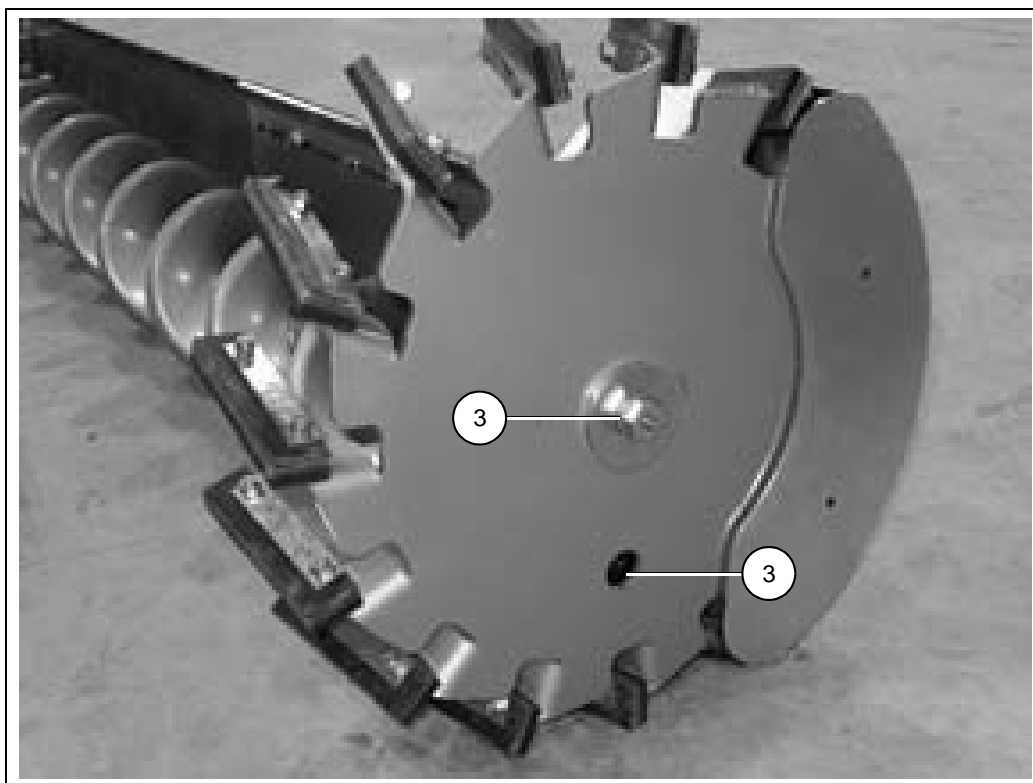

Figure 7E

Ref #	Description
1	Gearbox U-Joint
2	Incline Elbow U-Joint
3	Sweep Drive Wheel

## 8. Unload Dimensions

All dimensions are in inches unless specified otherwise.

### U-Trough Unload Dimensions

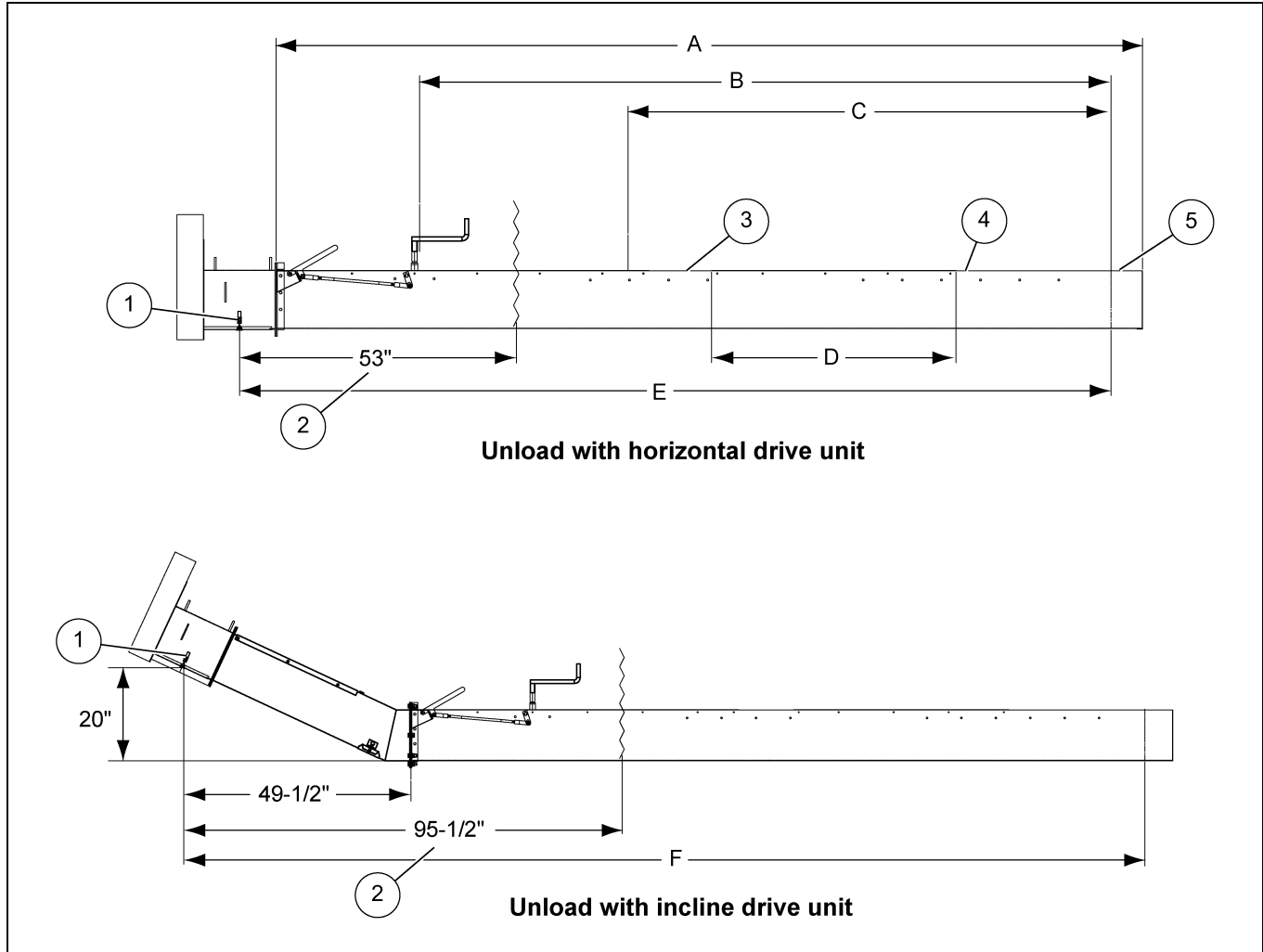

Figure 8A

Ref #	Description
1	Center of Discharge
2	Dimension for Standard Bin Size
3	Intermediate Gate
4	Center Gate
5	Center of Bin



## 8. Unload Dimensions

Standard Bin Diameter	# of Intermediate Gates	A	B	C	D	E	F
		Overall Unload Length	Maximum Bin Radius	Minimum Bin Radius	Distance Between Gates	Center of Bin to Center of Discharge Horizontal Drive Unit	Center of Bin to Center of Discharge Incline Drive Unit
15'	1	143.5	110	70	24.4	144.5	187
18'	1	160	126.5	86.5	40.9	161	203.5
19'	1	166	132.5	92.5	46.9	167	209.5
21'	1	178	144.5	104.5	58.9	179	221.5
24'	1	196	162.5	122.5	76.9	197	239.5
27'	2	214	180.5	140.5	41.4	215	257.5
30'	2	232	198.5	158.5	50.4	233	275.5
33'	2	250	216.5	176.5	59.4	251	293.5
36'	2	268	234.5	194.5	68.4	269	311.5
42'	3	304	270.5	230.5	53.6	305	347.5
48'	3	339	305.5	265.5	65.3	340	382.5
54'	3	376	342.5	302.5	77.6	377	419.5
60'	4	412	378.5	338.5	64.2	413	455.5
66'	4	452	396	356	74	451	497.38

## 8. Unload Dimensions

### Bin Sweep Dimensions

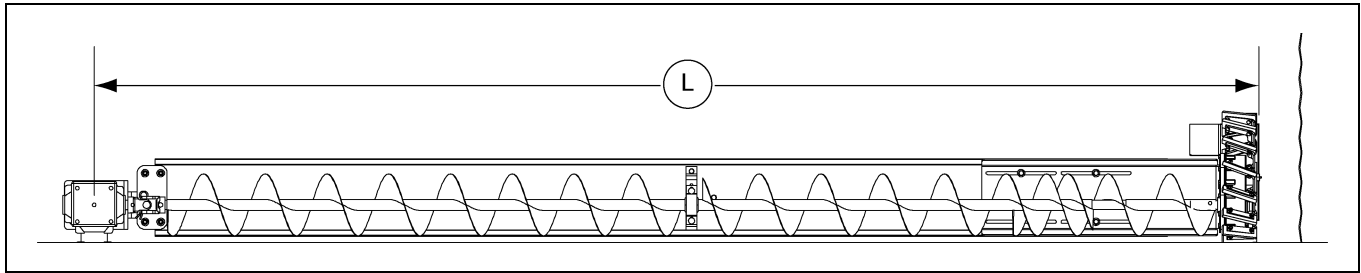

Figure 8B

Nominal Bin Diameter	Sweep Length (L) (in.)		Bin Diameter Range (ft.) Allowing 4-1/2" Clearance between Sweep and Bin Wall	
	Minimum Diameter	Maximum Diameter	Minimum	Maximum
18'	97.5	106.5	17.0	18.5
21'	115.5	124.5	20.0	21.5
24'	133.5	142.5	23.0	24.5
27'	151.5	160.5	26.0	27.5
30'	169.5	178.5	29.0	30.5
33'	187.5	196.5	32.0	33.5
36'	205.5	214.5	35.0	36.5
42'	241.5	250.5	41.0	42.5
45'	259.5	268.5	44.0	45.5
48'	277.5	286.5	47.0	48.5
54'	313.5	322.5	53.0	54.5
57'	331.5	340.5	56.0	57.5
60'	349.5	358.5	59.0	60.5

## Limited Warranty - N.A. Grain Products

The GSI Group, LLC. ("GSI") warrants products which it manufactures, to be free of defects in materials and workmanship under normal usage and conditions for a period of 12 months from the date of shipment (or, if shipped by vessel, 14 months from the date of arrival at the port of discharge). If, in GSI's sole judgment, a product is found to have a defect in materials and/or workmanship, GSI will, at its own option and expense, repair or replace the product or refund the purchase price. This Limited Warranty is subject to extension and other terms as set forth below.

### Warranty Enhancements:

The warranty period for the following products is enhanced as shown below and is in lieu of (and not in addition to) the above stated warranty period. (Warranty Period is from date of shipment.)

	Product	Warranty Period
<b>Storage</b>	Grain Bin Structural Design	5 Years
	• Sidewall, roof, doors, platforms and walk arounds	
	• Flooring (when installed using GSI specified floor support system for that floor)	
<b>Conditioning</b>	Dryer Structural Design - (Tower, Portable and TopDry)	5 Years
	• Includes (frame, portable dryer screens, ladders, access doors and platforms)	2 Years
	All other Dryer parts including:	
	• Electrical (controls, sensors, switches and internal wiring)	
	Bullseye Controllers	2 Years
<b>Material Handling</b>	Bucket Elevators Structural Design	5 Years
	Towers Structural Design	5 Years
	Catwalks Structural Design	5 Years
	Accessories (stairs, ladders and platforms) Structural Design	5 Years

### Conditions and Limitations:

THERE ARE NO WARRANTIES THAT EXTEND BEYOND THE LIMITED WARRANTY DESCRIPTION SET FORTH HEREIN; SPECIFICALLY, GSI DISCLAIMS ANY AND ALL OTHER WARRANTIES OF ANY KIND, EXPRESS OR IMPLIED, INCLUDING, WITHOUT LIMITATION, WARRANTIES OF MERCHANTABILITY OR FITNESS FOR A PARTICULAR PURPOSE OR USE IN CONNECTION WITH: (I) ANY PRODUCT MANUFACTURED OR SOLD BY GSI, OR (II) ANY ADVICE, INSTRUCTION, RECOMMENDATION OR SUGGESTION PROVIDED BY AN AGENT, REPRESENTATIVE OR EMPLOYEE OF GSI REGARDING OR RELATED TO THE CONFIGURATION, INSTALLATION, LAYOUT, SUITABILITY FOR A PARTICULAR PURPOSE, OR DESIGN OF SUCH PRODUCTS.

The sole and exclusive remedy for any claimant is set forth in this Limited Warranty and shall not exceed the amount paid for the product purchased. This Warranty only covers the value of the warranted parts and equipment, and does not cover labor charges for removing or installing defective parts, shipping charges with respect to such parts, any applicable sales or other taxes, or any other charges or expenses not specified in this Warranty. GSI shall not be liable for any other direct, indirect, incidental or consequential damages, including, without limitation, loss of anticipated profits or benefits. Expenses incurred by or on behalf of a claimant without prior written authorization from the GSI warranty department shall not be reimbursed. This warranty is not transferable and applies only to the original end-user. GSI shall have no obligation or responsibility for any representations or warranties made by or on behalf of any dealer, agent or distributor. Prior to installation, the end-user bears all responsibility to comply with federal, state and local codes which apply to the location and installation of the products.

This Limited Warranty extends solely to products sold by GSI and does not cover any parts, components or materials used in conjunction with the product, that are not sold by GSI. GSI assumes no responsibility for claims resulting from construction defects, unauthorized modifications, corrosion or other cosmetic issues caused by storage, application or environmental conditions. Modifications to products not specifically delineated in the manual accompanying the product at initial sale will void all warranties. This Limited Warranty shall not extend to products or parts which have been damaged by negligent use, misuse, alteration, accident or which have been improperly/inadequately maintained.

#### Notice Procedure:

In order to make a valid warranty claim a written notice of the claim must be submitted, using the RMA form, within 60 days of discovery of a warrantable nonconformance. The RMA form is found on the OneGSI portal.

#### Service Parts:

GSI warrants, subject to all other conditions described in this Warranty, Service Parts which it manufactures for a period of 12 months from the date of purchase unless specified in Enhancements above.

(Limited Warranty - N.A. Grain Products\_ revised 01 September 2020)

This equipment shall be installed in accordance with the current installation codes and applicable regulations, which should be carefully followed in all cases. Authorities having jurisdiction should be consulted before installations are made.



**1004 E. Illinois St.**  
**Assumption, IL 62510-0020**  
**Phone: 1-217-226-4421**  
**Fax: 1-217-226-4420**  
**[www.gsiag.com](http://www.gsiag.com)**

