

Direct Gear Drive Bin Sweep

Models:
10" HEAVY DUTY

Installation and Operation Manual

PNEG-2129
Version 3.1

Date: 08-30-18



PNEG-2129

All information, illustrations, photos, and specifications in this manual are based on the latest information available at the time of publication. The right is reserved to make changes at any time without notice.

Contents

Chapter 1	Safety Precautions	5
	Safety Guidelines	5
	Cautionary Symbol Definitions.....	6
	Safety Cautions.....	7
	Safety Decals	10
	Safety Sign-off Sheet.....	13
Chapter 2	General Information	15
	Sweep Offerings and Sweep Arm Details	15
	Short Sweeps	16
Chapter 3	Installation	17
	Power Sweeps in Bins with Concrete Floors.....	18
	Installing the Unload Tube.....	19
	Installing the Bin Flange.....	23
	Installing the Center Well Gate	25
	Installing the Auxiliary Intermediate Well (Optional).....	26
	Installing the Rack and Pinion	33
	Installing the Clutch Control	38
	Installing the Unload Tube Flight.....	45
	Installing Intermediate Well Flange	47
	Assembling the Sweep Flighting to the Backshield (60 Ft — 72 Ft Bins)	48
	Assembling the Sweep Support Skid	50
	Installing the Sweep Flighting.....	51
	Installing the Flighting Shield.....	55
	Installing the Sweep Wheel.....	57
	Adjusting the Wiper	60
	Adjusting the Sweep Support Skid.....	62
	Installing the Backshield Support Assembly.....	63
Chapter 4	Operation	65
	Power Recommendations.....	65
	Before Filling the Bin	66
	Performing Pre-Start Checks.....	68
	Operating the Auger	69
	Engaging the Clutch for Bin Sweep.....	72
	Final Clean Out.....	74
Chapter 5	Shut Down	75
	Normal Shut Down	75
	Emergency Shut Down	75
	Storage Preparation	75
Chapter 6	Maintenance and Troubleshooting	77
	Maintaining the Auger.....	77
	Troubleshooting	78
Chapter 7	Parts List	79
	Center Well.....	80
	Intermediate Well (30 Ft — 36 Ft Bins).....	82
	Outside Intermediate Well (For 42 Ft and Larger Bins)	83
	Auxiliary Kits (Optional).....	84
	Single Rack and Pinion (30 Ft — 36 Ft).....	88
	Double Rack and Pinion (42 Ft — 72 Ft)	89
	Bin Flange	90
	Sweep Wheel	91
	Unload Tube Flight	92
	Clutch Control.....	96
	Backshield with Two Augers for Standard Sweeps (30 Ft Bins).....	98

Backshield with Two Augers for Short Sweeps (30 Ft Bins).....	100
Backshield with Three Augers for Standard Sweeps (33 Ft – 42 Ft Bins)	102
Backshield with Three Augers for Short Sweeps (33 Ft – 42 Ft Bins)	104
Backshield with Four Augers for Standard Sweeps (48 Ft and 54 Ft Bins).....	106
Backshield with Four Augers Short Sweeps (48 Ft and 54 Ft Bins).....	110
Backshield with Five Augers for Standard Sweeps (60 Ft and 66 Ft Bins)	114
Backshield with Five Augers for Short Sweeps (60 Ft and 66 Ft Bins).....	118
Backshield with Six Augers for Standard Sweeps (72 Ft Bins).....	122
Backshield with Six Augers for Short Sweeps (72 Ft Bins)	124
Backshield Connections	126
GSI Group, LLC Limited Warranty	127

1 Safety Precautions

Topics Covered in this Chapter

- Safety Guidelines
- Cautionary Symbol Definitions
- Safety Cautions
- Safety Decals
- Safety Sign-off Sheet

Safety Guidelines

Safety guidelines are general-to-specific safety rules that must be followed at all times. This manual is written to help you understand safe operating procedures and problems that can be encountered by the operator and other personnel when using this equipment. Save these safety guidelines for future reference.

As owner or operator, you are responsible for understanding the requirements, hazards, and precautions that exist and to inform others as required. Unqualified persons must stay out of the work area at all times.

Alterations must not be made to the equipment. Alterations can produce dangerous situations resulting in **SERIOUS INJURY** or **DEATH**.

This equipment must be installed in accordance with the current installation codes and applicable regulations, which must be carefully followed in all cases. Authorities having jurisdiction must be consulted before installations are made.

When necessary, you must consider the installation location relative to electrical, fuel and water utilities.







Personnel operating or working around equipment must read this manual. This manual must be delivered with equipment to its owner. Failure to read this manual and its safety instructions is a misuse of the equipment.

ST-0001-3

Cautionary Symbol Definitions

Cautionary symbols appear in this manual and on product decals. The symbols alert the user of potential safety hazards, prohibited activities and mandatory actions. To help you recognize this information, we use the symbols that are defined below.

Table 1-1 Description of the different cautionary symbols

Symbol	Description
	This symbol indicates an imminently hazardous situation which, if not avoided, will result in serious injury or death.
	This symbol indicates a potentially hazardous situation which, if not avoided, can result in serious injury or death.
	This symbol indicates a potentially hazardous situation which, if not avoided, can result in minor or moderate injury.
	This symbol is used to address practices not related to personal injury.
	This symbol indicates a general hazard.
	This symbol indicates a prohibited activity.
	This symbol indicates a mandatory action.

ST-0005-2

Safety Cautions

Use Personal Protective Equipment

- Use appropriate personal protective equipment:

Eye Protection



Respiratory Protection



Foot Protection



Hearing Protection



Head Protection



Fall Protection



Hand Protection



- Wear clothing appropriate to the job.
- Remove all jewelry.
- Tie long hair up and back.

ST-0004-1

Follow Safety Instructions

- Carefully read all safety messages in this manual and safety signs on your machine. Keep signs in good condition. Replace missing or damaged safety signs. Be sure new equipment components and repair parts include the current safety signs. Replacement safety signs are available from the manufacturer.
- Learn how to operate the machine and how to use controls properly. Do not let anyone operate without instruction.
- If you do not understand any part of this manual or need assistance, contact your dealer.



ST-0002-1

Chapter 1: Safety Precautions

Maintain Equipment and Work Area

- Understand service procedures before doing work. Keep area clean and dry.
- Never service equipment while it is operating. Keep hands, feet, and clothing away from moving parts.
- Keep your equipment in proper working condition. Replace worn or broken parts immediately.



ST-0003-1

Operate Motor Properly

- All electrical connections must be made in accordance with applicable local codes (National Electrical Code for the US, Canadian Electric Code, or EN60204 along with applicable European Directives for Europe). Make sure equipment and bins are properly grounded.
- Lock-out power before resetting motor overloads.
- Do not repetitively stop and start the drive in order to free a plugged condition. Jogging the drive in this manner can damage the equipment and drive components.



ST-0009-3

Rotating Auger Hazard

- Keep clear of rotating augers and moving parts.
- Do not remove or modify guards or covers.
- Lock-out power source before making adjustments, cleaning, or maintaining equipment.
- Failure to follow these precautions will result in serious injury or death.



ST-0037-1

Stay Clear of Hoisted Equipment

- Always use proper lifting or hoisting equipment when assembling or disassembling equipment
- Do not walk or stand under hoisted equipment.
- Always use sturdy and stable supports when needed for installation. Not following these safety precautions creates the risk of falling equipment, which can crush personnel and cause serious injury or death.



ST-0047-1

Stay Clear of Rotating Parts

- Do not enter the bin while the equipment is in operation.
- Entanglement in rotating augers will cause serious injury or death.
- Keep all guards and covers in place at all times.
- Lock-out power source before making adjustments, cleaning, or maintaining equipment.



ST-0008-2

Use Unload Equipment Properly

- Do not operate this equipment alone. Make sure someone nearby is aware of the proper shut down sequence in the event of an emergency.
- Do not allow any person intoxicated or under the influence of drugs to operate this equipment. All operators must be adequately rested and prepared to perform all functions of operating the equipment.
- Do not start equipment until all persons are clear of the work area and safety guards are in place.
- Do not allow anyone inside a bin, truck, or wagon which is being unloaded by an auger. Flowing grain can trap and suffocate in seconds.
- Use ample overhead lighting after sunset to light the work area.
- Always use caution to not hit the auger when positioning the load.
- Do not leave equipment operating while unattended.
- Be aware of pinch points, which can trap or catch objects and cause injury.
- Be sure all equipment is locked in position before operating.
- Always lock out all power sources to the equipment when unloading is finished.



ST-0051-1



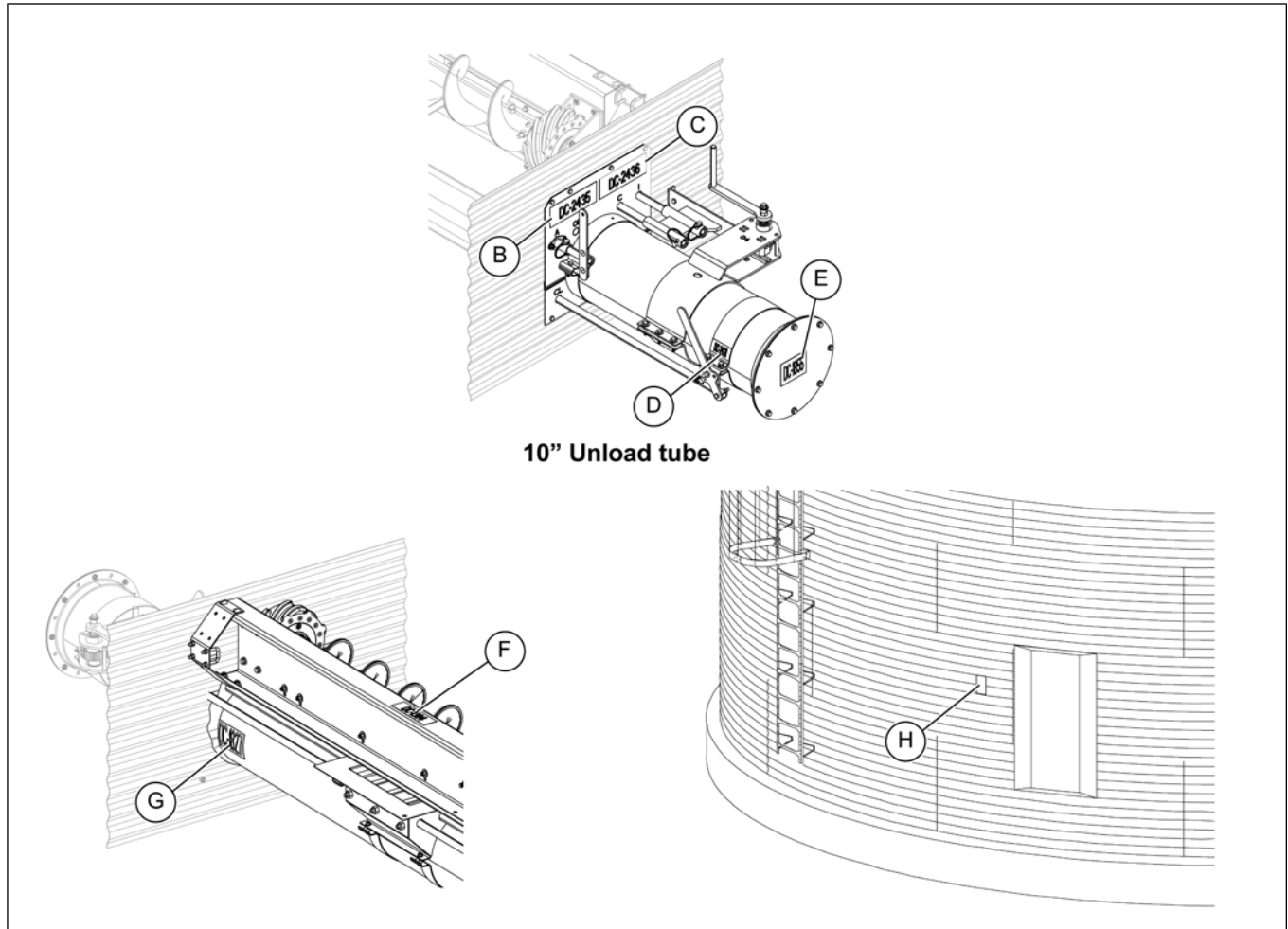

Safety Decals

Check components shown below to ensure that the safety decals are in place and in good condition. If a decal cannot be easily read for any reason or has been painted over, replace it immediately. Contact your dealer or the manufacturer to order a replacement decal free of charge.

Figure 1-1 Decal locations

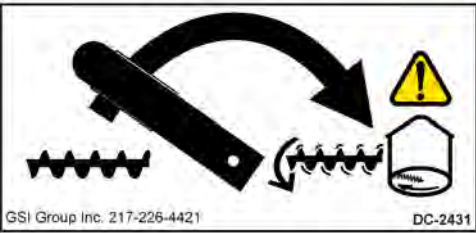

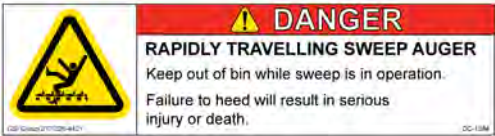
Ref #	Location	Decal No.	Decal	Description
B	Upper bin flange	DC-2435		Decal, sweep operating instructions – 10 in.
C	Upper bin flange	DC-2436		Decal, Danger Sweep auger

Ref #	Location	Decal No.	Decal	Description
D	Clutch control upper half band	DC-2431		Decal, power sweep engage
E	Unload tube flange	DC-1855		Decal, control pipe
F	Flighting shield top	DC-1384		Decal, keep out of bin
G	Unload tube side	DC-1827		decal, do not handle

Chapter 1: Safety Precautions

Ref #	Location	Decal No.	Decal	Description
H	Bin sidewall	DC-1395		Decal, rotating flight

To replace a damaged or missing decal, contact us to receive a free replacement.

GSI Decals

1004 E. Illinois St.
 Assumption, IL 62510
 Tel: 1-217-226-4421

NOTES

2 General Information

Topics Covered in this Chapter

- Sweep Offerings and Sweep Arm Details
- Short Sweeps

Sweep Offerings and Sweep Arm Details

When sweep is used with standard 2-ring farm door on all plenum heights, standard sweep length can be used.

Figure 2-1 Sweep details

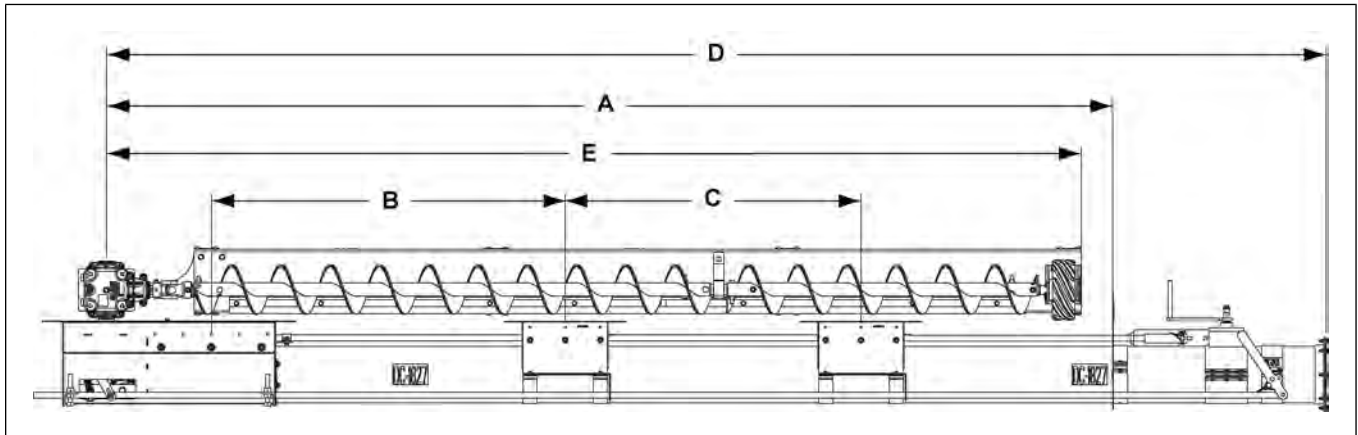

Table 2-1 Details for 10 in.

Bin Diameter	# of Intermediate Wells	Distance from Center of Bin to Wall (A)	Distance between Center Well Gate and First Intermediate Well (B)	Distance between Intermediate Wells (C)	Distance from Center of bin to Angle Ring (D)	Distance between Center of Bin to End of Sweep (E)
30'	2	14' - 11"	4' - 2-1/4"	60"	17' - 5-3/16"	14' - 7-1/2"
33'	3	16' - 4-15/16"		42"	18' - 11-3/16"	16' - 1-1/2"
36'	3	17' - 10-7/8"		60"	20' - 5-3/16"	17' - 7"
42'	4	20' - 10-11/16"		54"	23' - 5-3/16"	20' - 6-1/2"
48'	4	23' - 10-1/2"		62"	26' - 5-3/16"	23' - 6-1/2"
54'	4	26' - 10-5/8"		66"	29' - 5-1/8"	26' - 6-7/16"
60'	5	29' - 10-1/2"		66"	32' - 5-3/16"	29' - 6-1/2"
66'	6	32' - 10-3/8"		60"	35' - 5-3/16"	32' - 6-1/2"
72'	6	35' - 10-3/16"		60"	38' - 7-3/16"	35' - 5-1/2"

Short Sweeps

A shortened sweep is required when using welded sleeve or double frame door with a plenum other than 12 in. The sweep arm is shortened approximately 7 in. from standard length for short sweep.

Figure 2-2 Sweep Details

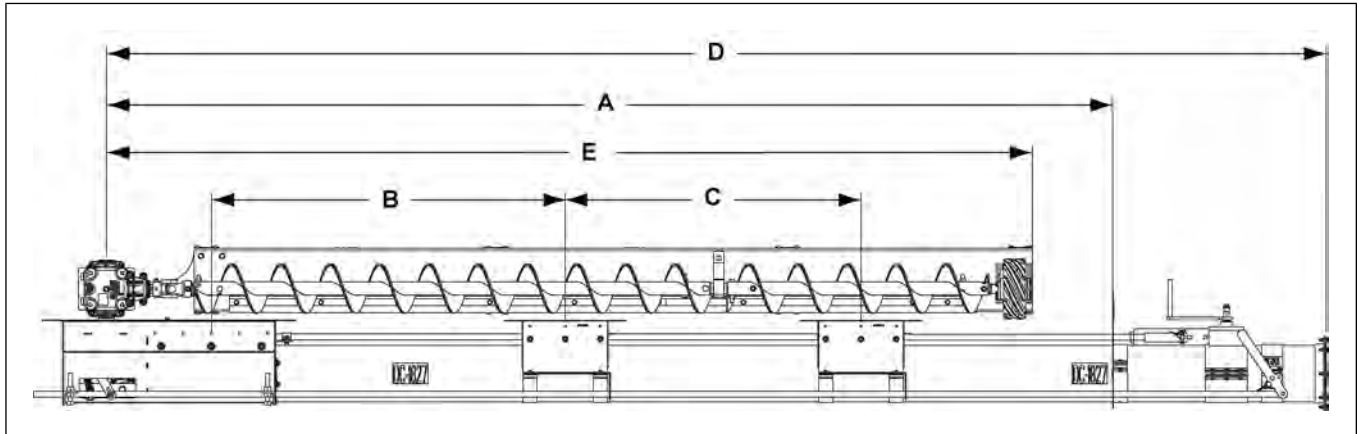

Table 2-2 Details for 10 in.

Bin Diameter	# of Intermediate Wells	Distance from Center of Bin to Wall (A)	Distance between Center Well Gate and First Intermediate Well (B)	Distance between Intermediate Wells (C)	Distance from Center of bin to Angle Ring (D)	Distance between Center of Bin to End of Sweep (E)
30'	2	14' - 11"	4' - 2-1/4"	60"	17' - 5-3/16"	14' - 1/2"
33'	3	16' - 4-15/16"		42"	18' - 11-3/16"	15' - 6-1/2"
36'	3	17' - 10-7/8"		60"	20' - 5-3/16"	17'
42'	4	20' - 10-11/16"		54"	23' - 5-3/16"	19' - 10-1/2"
48'	4	23' - 10-1/2"		62"	26' - 5-3/16"	22' - 10-1/2"
54'	4	26' - 10-5/8"		66"	29' - 5-1/8"	25' - 10-7/16"
60'	5	29' - 10-1/2"		66"	32' - 5-3/16"	28' - 10-1/2"
66'	6	32' - 10-3/8"		60"	35' - 5-3/16"	31' - 10-1/2"
72'	6	35' - 10-3/16"		60"	38' - 7-3/16"	34' - 9-1/2"

3 Installation

Topics Covered in this Chapter

- Power Sweeps in Bins with Concrete Floors
- Installing the Unload Tube
- Installing the Bin Flange
- Installing the Center Well Gate
- Installing the Auxiliary Intermediate Well (Optional)
- Installing the Rack and Pinion
- Installing the Clutch Control
- Installing the Unload Tube Flight
- Installing Intermediate Well Flange
- Assembling the Sweep Flighting to the Backshield (60 Ft — 72 Ft Bins)
- Assembling the Sweep Support Skid
- Installing the Sweep Flighting
- Installing the Flighting Shield
- Installing the Sweep Wheel
- Adjusting the Wiper
- Adjusting the Sweep Support Skid
- Installing the Backshield Support Assembly

Power Sweeps in Bins with Concrete Floors

NOTE: GSI does not recommend setting the power sweep unit in concrete. If installing a unit flush with a concrete floor, it is recommended the unit be installed in a performed trench using the image shown.

Figure 3-1 Floor view

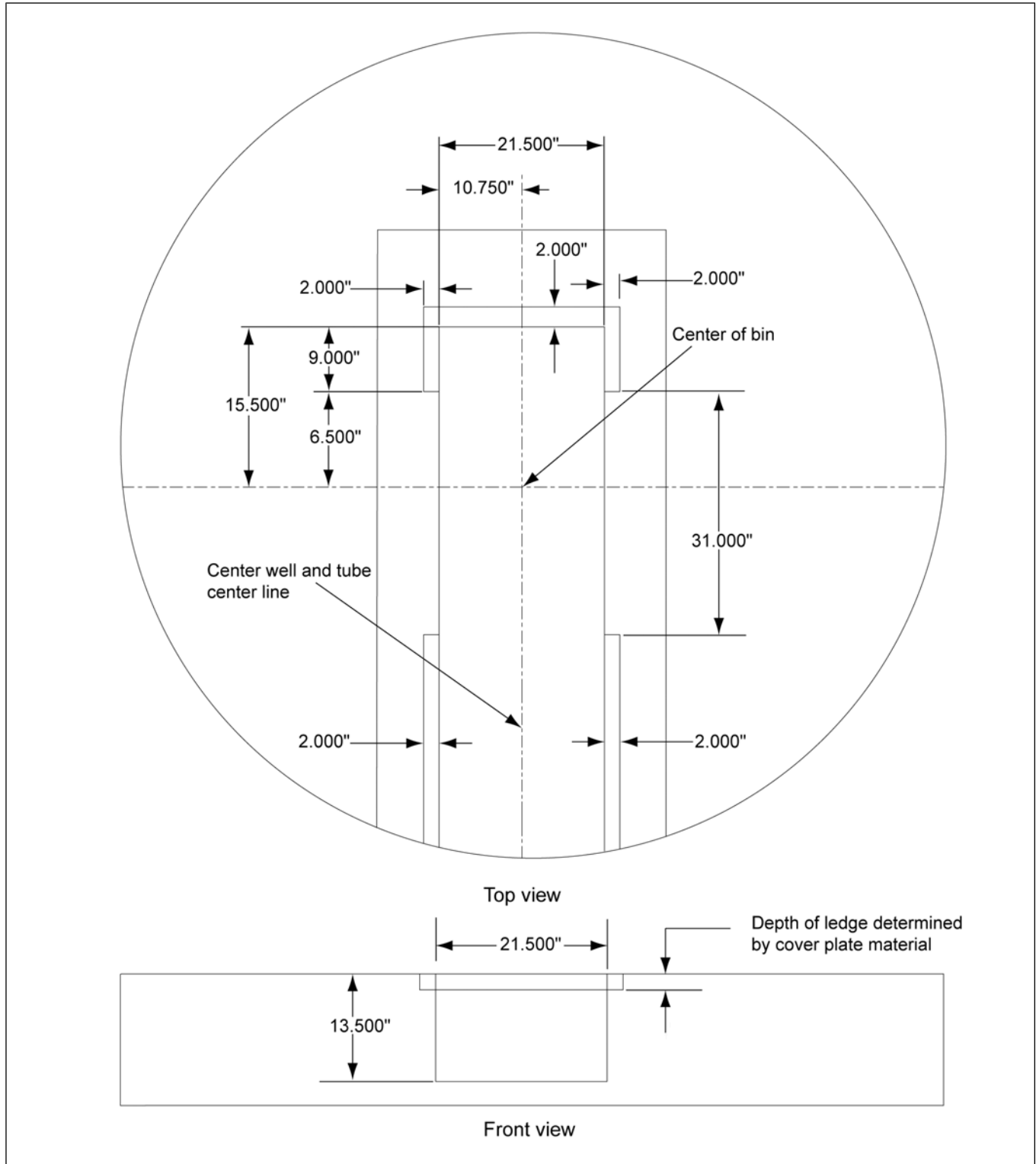

Installing the Unload Tube

- 1. Cut an opening in the bin wall for the unloading tube to pass through.

Figure 3-2 10 in. Tube

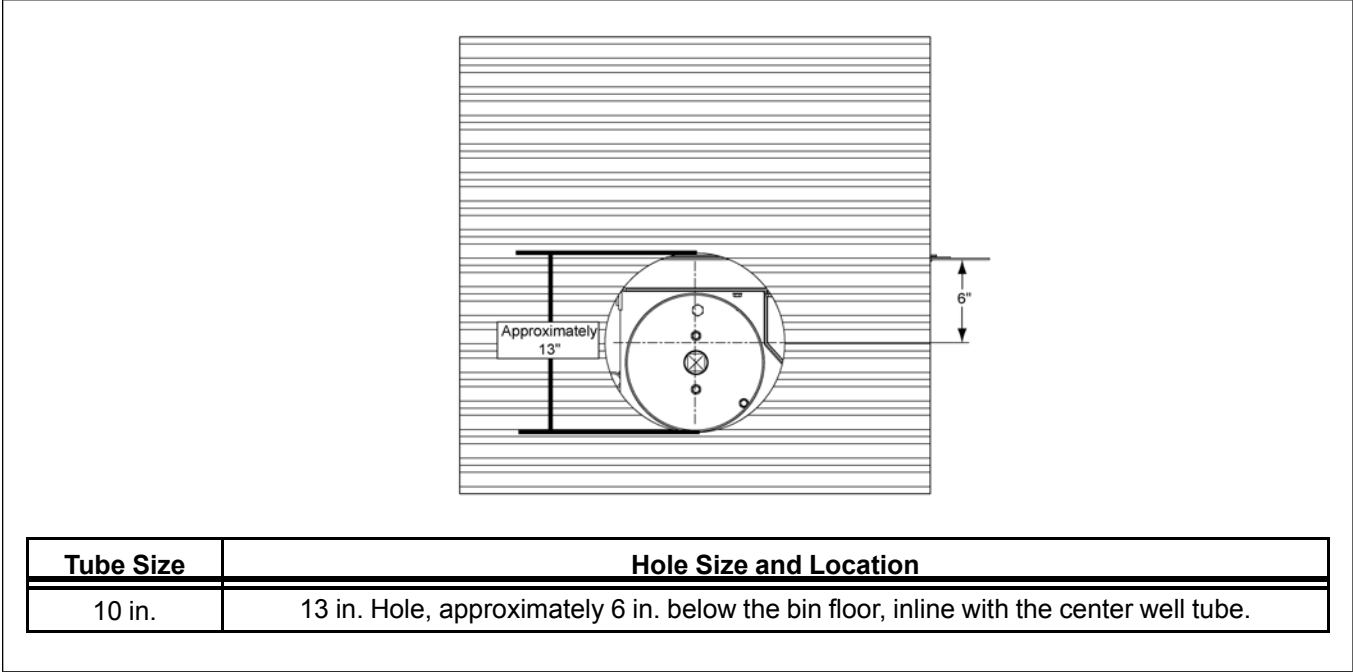

Chapter 3: Installation

2. From inside the bin, insert the angle ring end of the unload tube through the hole in the bin sidewall.

NOTE: Before installing tube, remove flight from inside of tube.

3. Insert the unload tube (2 and 3) into the center well (1) till the tube flange aligns to the outside of the center well and secure using serrated flange bolts (4) serrated flange nuts (5).

NOTE: For 10" – Six (6) 3/8 x 3/4 in. bolts

Figure 3-3 Secure the center well to unload tube

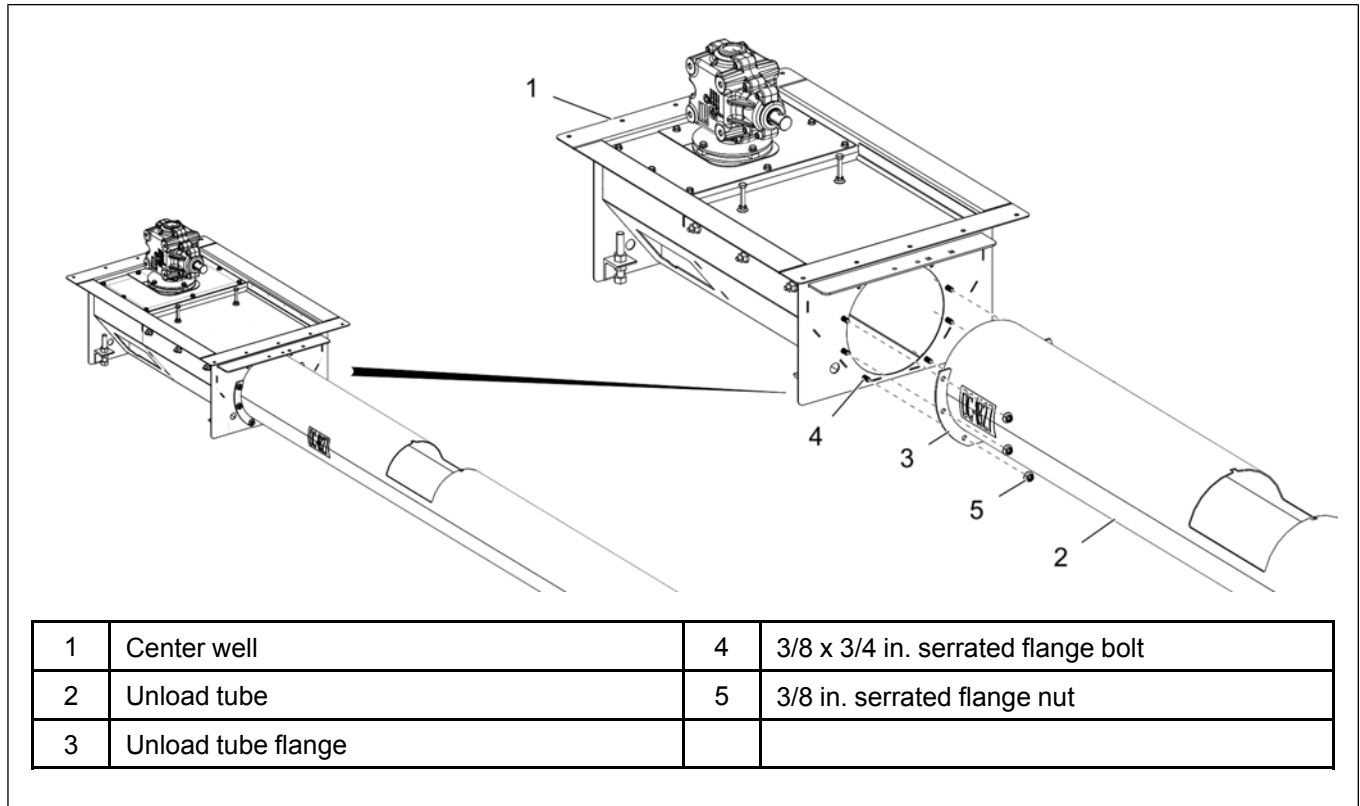

NOTE: In order to install the carriage bolts, the gate needs to be attached to the pipe PRIOR to assembling the tube to the center well. Extend the center well pipe off the end of the tube and slide the gate out of the well. This will give the space to tighten the nuts.

4. Locate the center of the bin and place the center well into position with the vertical shaft in the gear-box at the center of the bin.

NOTE: When placing the center well at the center of the bin, GSI recommends a tolerance of ± 0.25 in. (both directions) for the slight adjustment of sweep length to enable the sweep to run without any interference.

NOTE: GSI does not recommend installing the Direct Gear Drive Power Sweep in concrete. When flush-floor installations are necessary, a pre-formed trench is needed. A steel trench cover adequate for the grain height and trench size must be installed. Consult the factory for further information.

Figure 3-4 Center well placement

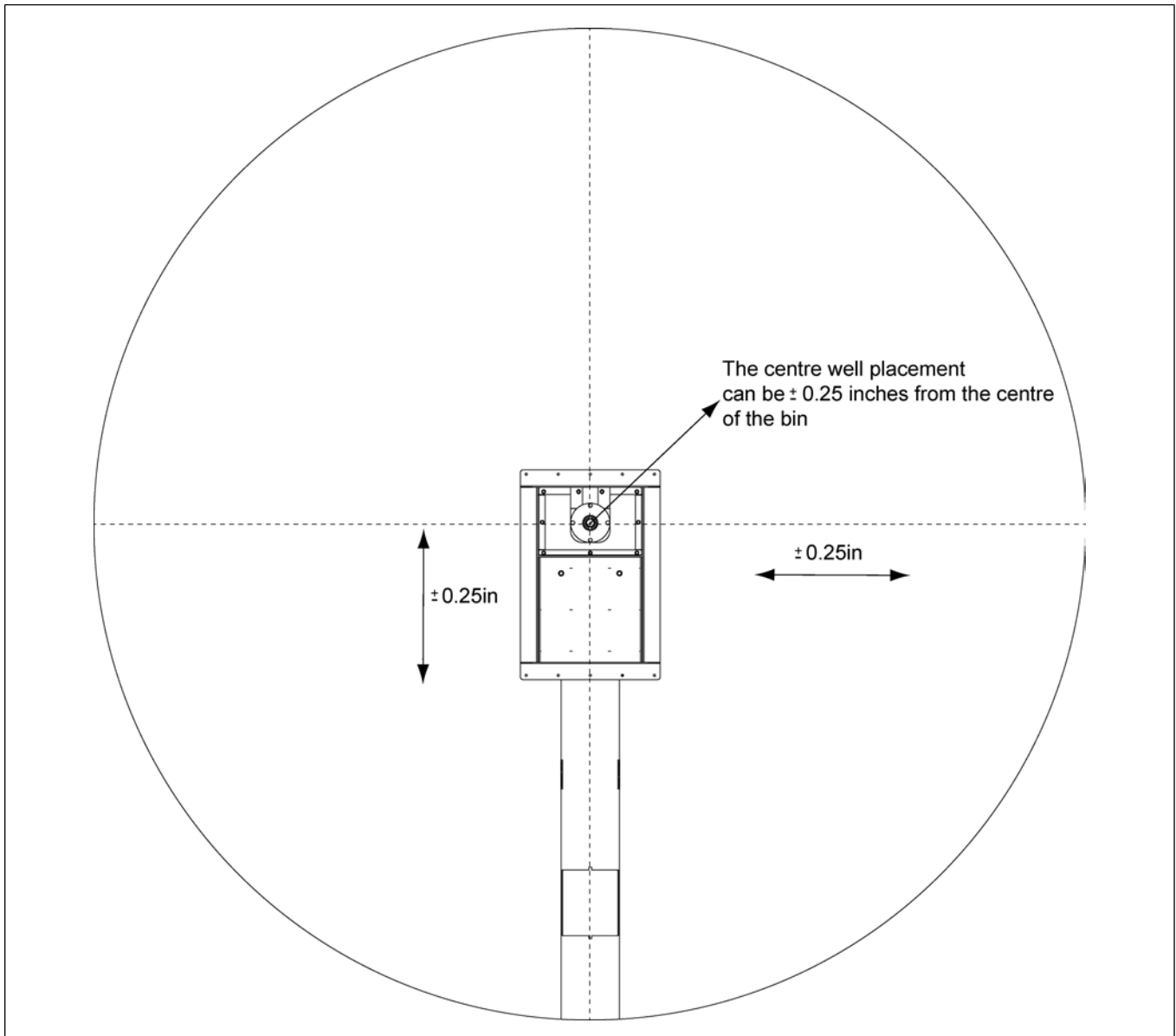

Chapter 3: Installation

5. Level the center well to the concrete floor by adjusting the HHTB bolt (62) lengths using both nuts (63) (above and below of center well angle) located at the bottom corners of the center well.

Figure 3-5 *Leveling of center well*

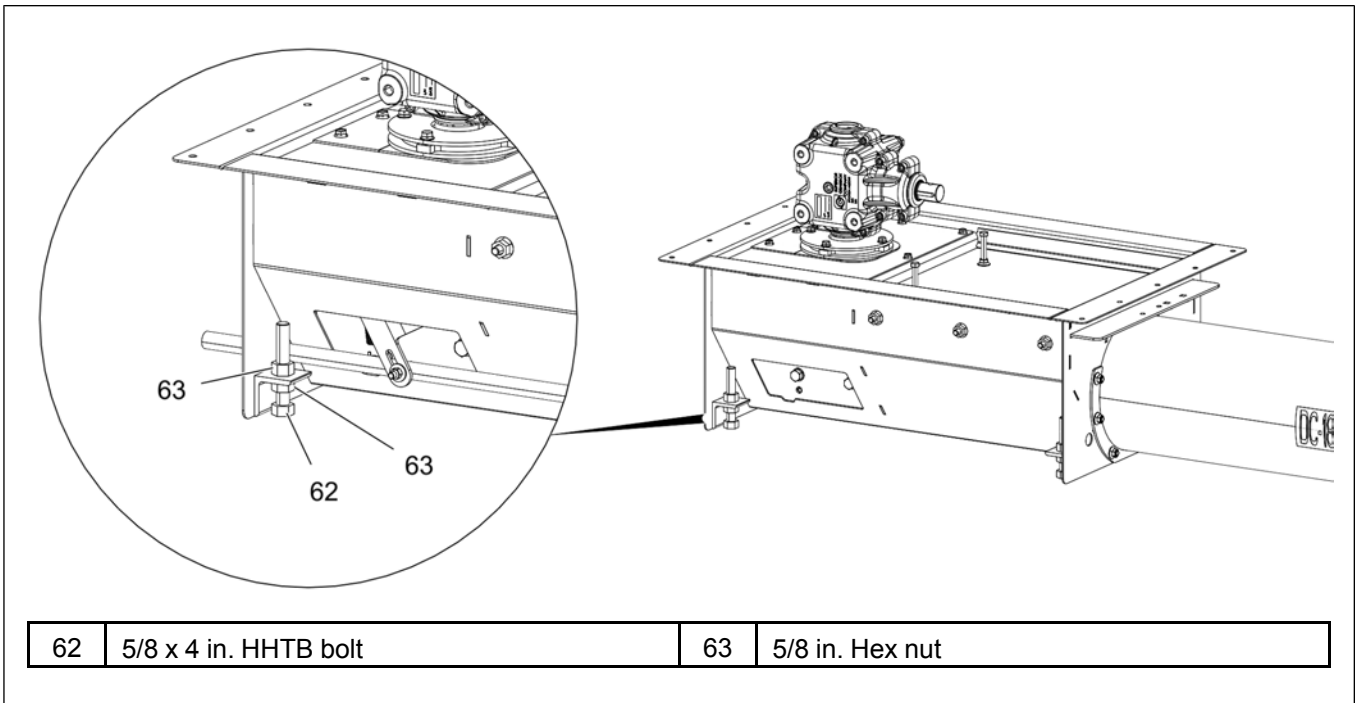

Installing the Bin Flange

1. Attach the upper bin flange (6) and lower bin flange (7) loosely to the unload tube using HHCS bolts (8) and serrated flange nuts (9).

Figure 3-6 *Installing the upper and lower bin flanges*

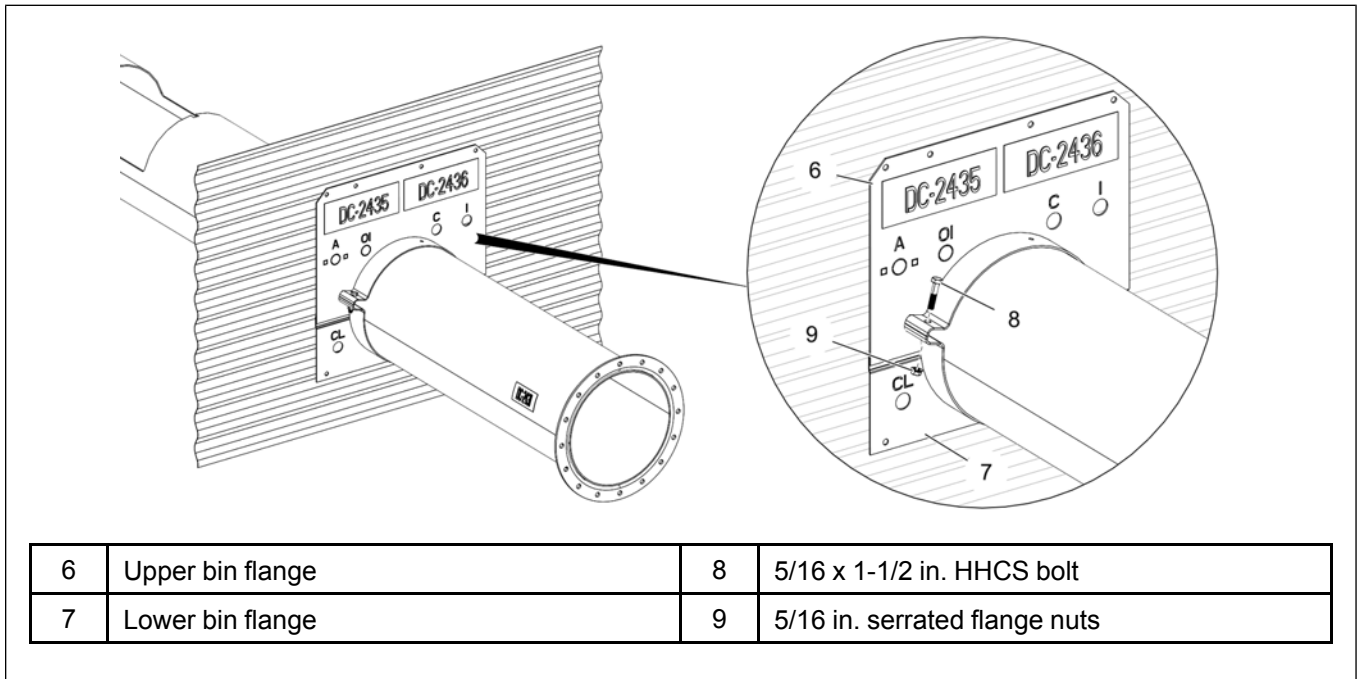

Chapter 3: Installation

2. With the flange not yet attached to the bin wall, make sure that the bin wall opening is large enough for the clutch and well control rods to pass through the bin wall.
3. Slide the bin flanges flush up to the bin wall and tighten the bolts connecting the two flanges.
4. Drill holes in the bin wall through the four holes located in the upper bin flange (6) and two holes located in lower bin flange (7) and secure the bin flanges to the bin wall using six bin standard bolts (A) and flange nuts (B).

Figure 3-7 Secure the upper and lower bin flanges

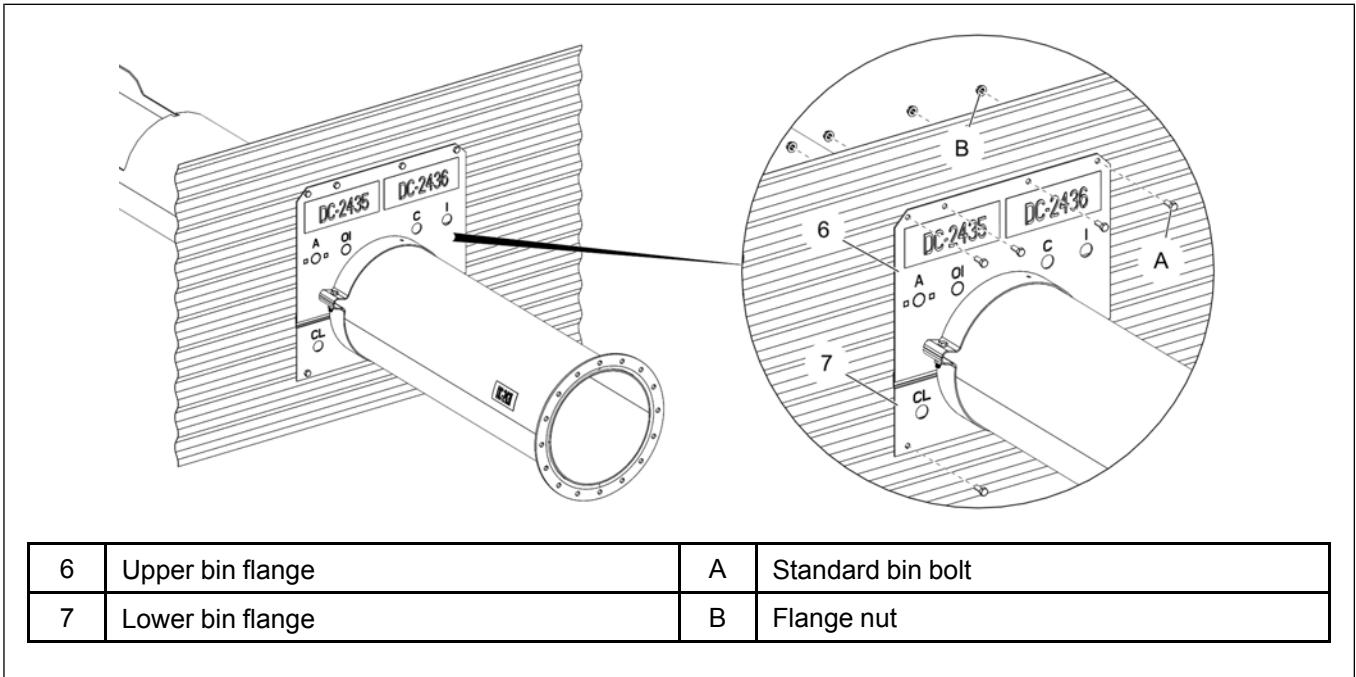

Installing the Center Well Gate

1. Close the center well gate (10) completely.
2. Align the center well control rod (11) between holes in gate.

NOTE: For 10 in. sweep, control rod attaches on the **BOTTOM** side of the center well gate.

3. Attach the control rod clamp (12) to control rod (11) with roll pin (15) through the clamp and control rod.
4. Secure the control rod clamp (12) to control gate by using bolts (13), flat washers (14) and serrated flange nuts (9).

NOTE: Use 5/16 in. carriage bolts (13) for 10 in. sweep.

Figure 3-8 10 in. Center well gate assembly

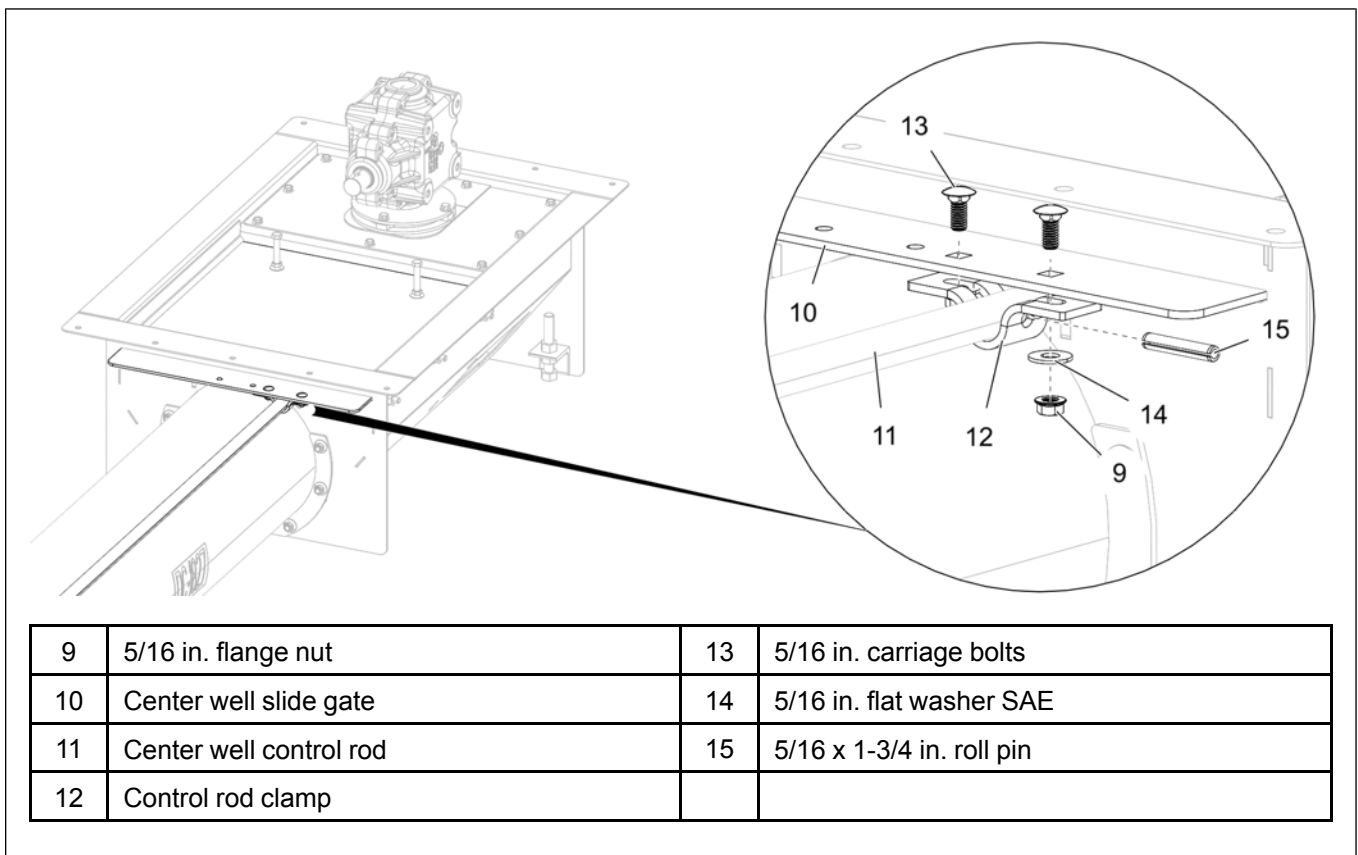

NOTE: In order to install the carriage bolts, the gate needs to be attached to the pipe **PRIOR** to assembling the tube to the center well. Extend the center well pipe off the end of the tube and slide the gate out of the well. This will give the space to tighten the nuts.

After You Finish

After assembly, make sure gate operates smoothly and closes completely. Make necessary adjustments.

Installing the Auxiliary Intermediate Well (Optional)

What You Should Know

If the center well becomes plugged during gravity unloading, this option allows the bin to still be unloaded until the plugged center well can be addressed. This control option allows the end user to independently control the intermediate closest to the center well

1. Install the auxiliary control rod guides (73) to all intermediate wells (65) using the HHTB bolts (71) and nylock nuts (72).

NOTE: *The control rod guide must mount to the intermediate well as shown for proper rod alignment to gate and wall flange.*

Figure 3-9 Installing the auxiliary rod guide to intermediate well

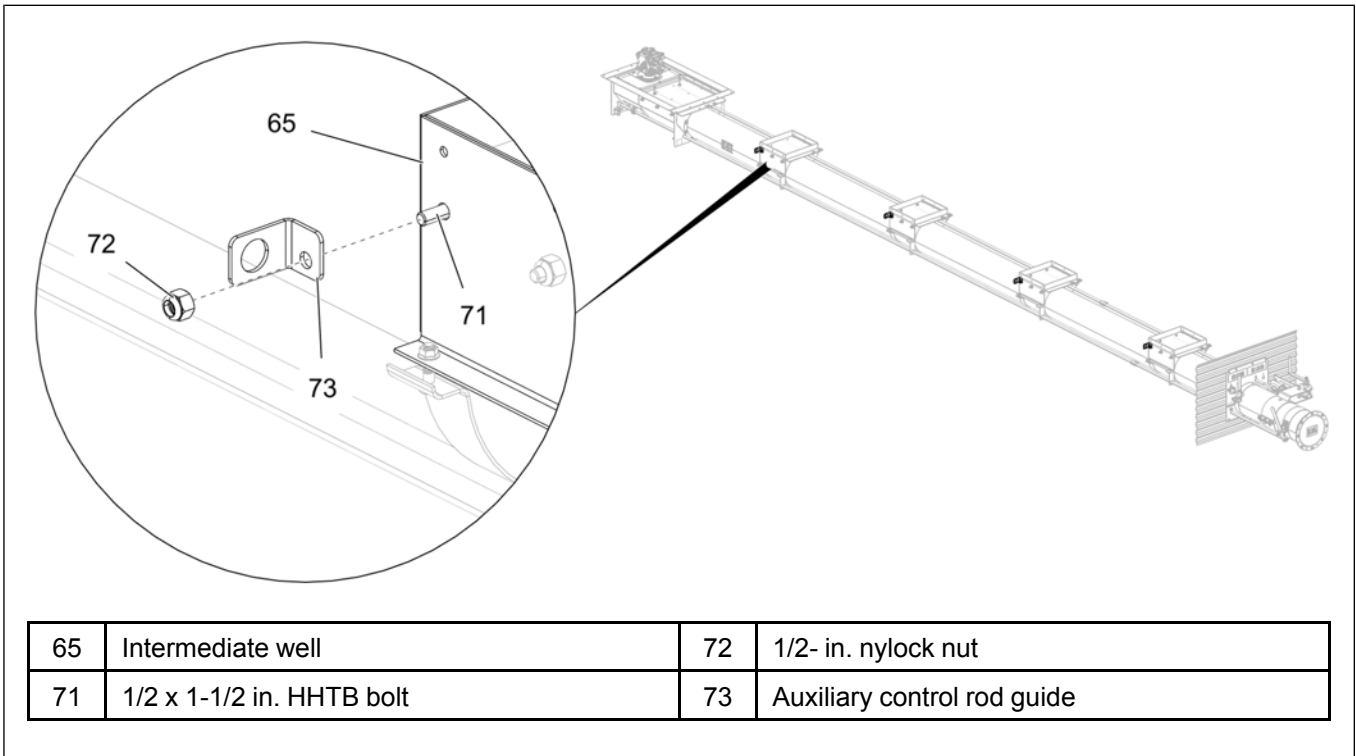

- Slide and remove the intermediate gate from the intermediate well next to the center well.

Figure 3-10 Removing the intermediate gate (8 in. sweep)

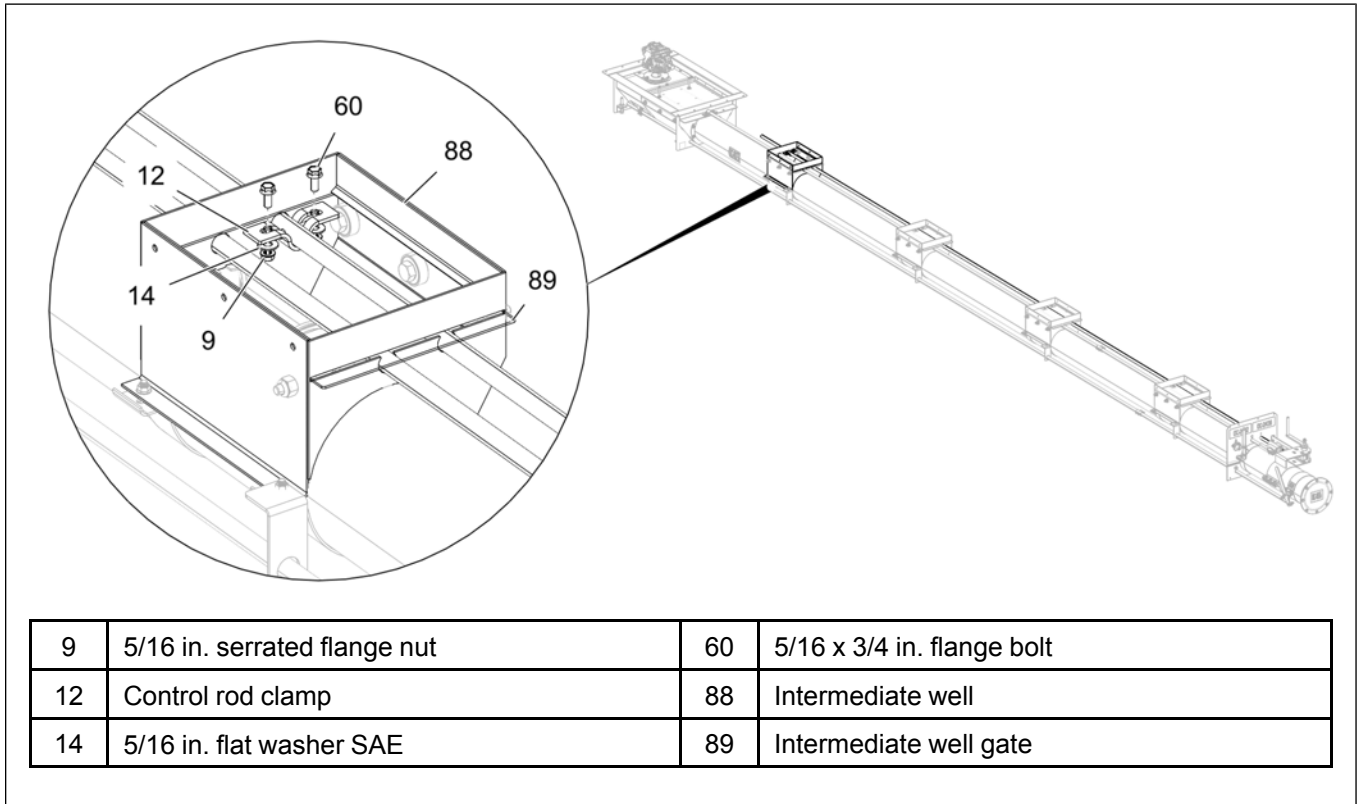

NOTE:

- Make sure to partially pull the intermediate gate (69) out to allow gap for removing the bolts (60) and nuts (9) inside the intermediate well (65) in a 10 in. sweep
- Make sure to remove the gate clamp (12), pin (15), bolts (13), washers (14) and in. nuts (9) at the outside of the intermediate well to remove the intermediate gate in a 10 in. sweep

Chapter 3: Installation

Figure 3-11 Removing the intermediate gate (10 in. sweep)

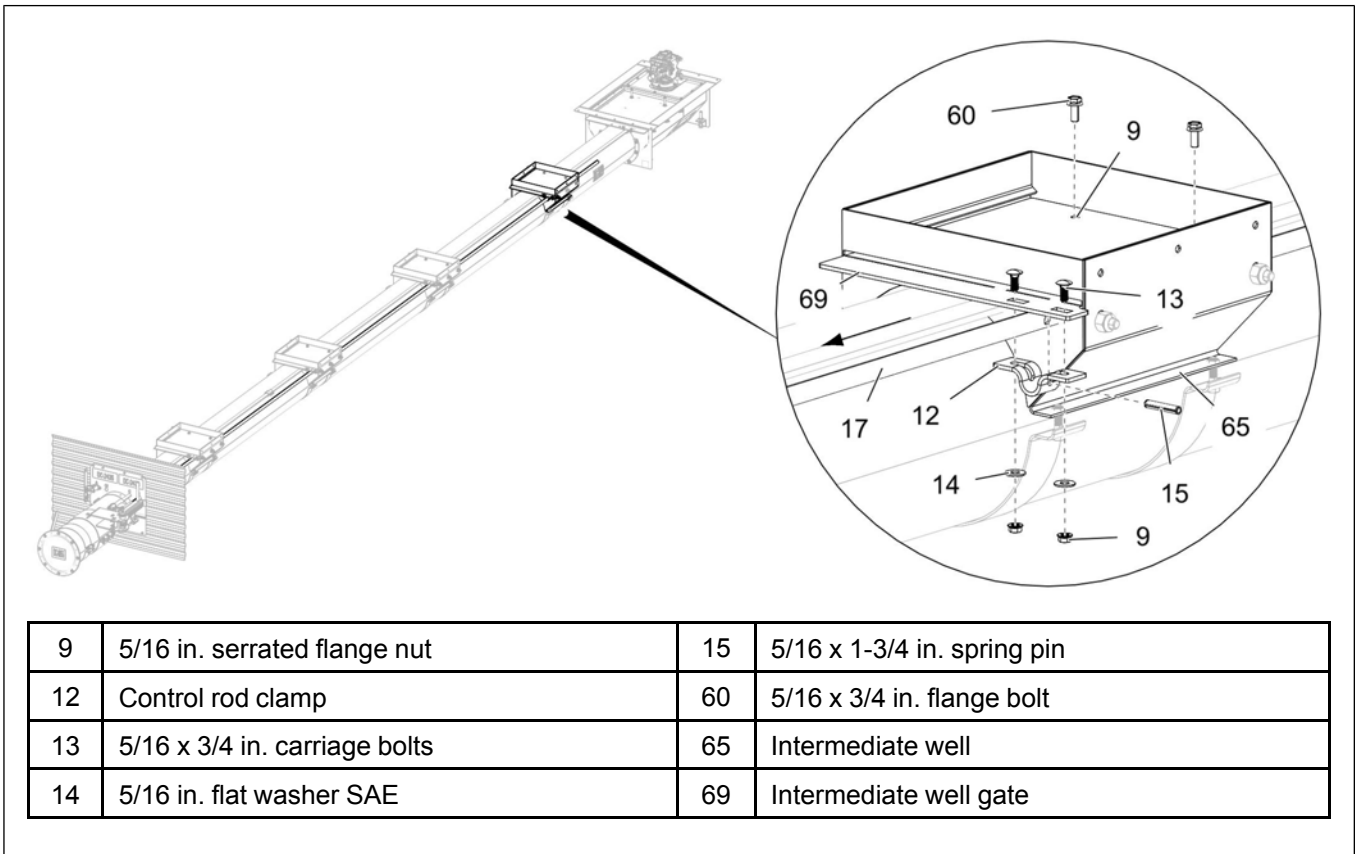

- Slide the auxiliary control rod (74) through the bin flange and auxiliary well control rod guide brackets (73) in the intermediate wells.

Figure 3-12 Sliding the auxiliary control rod through rod guide bracket

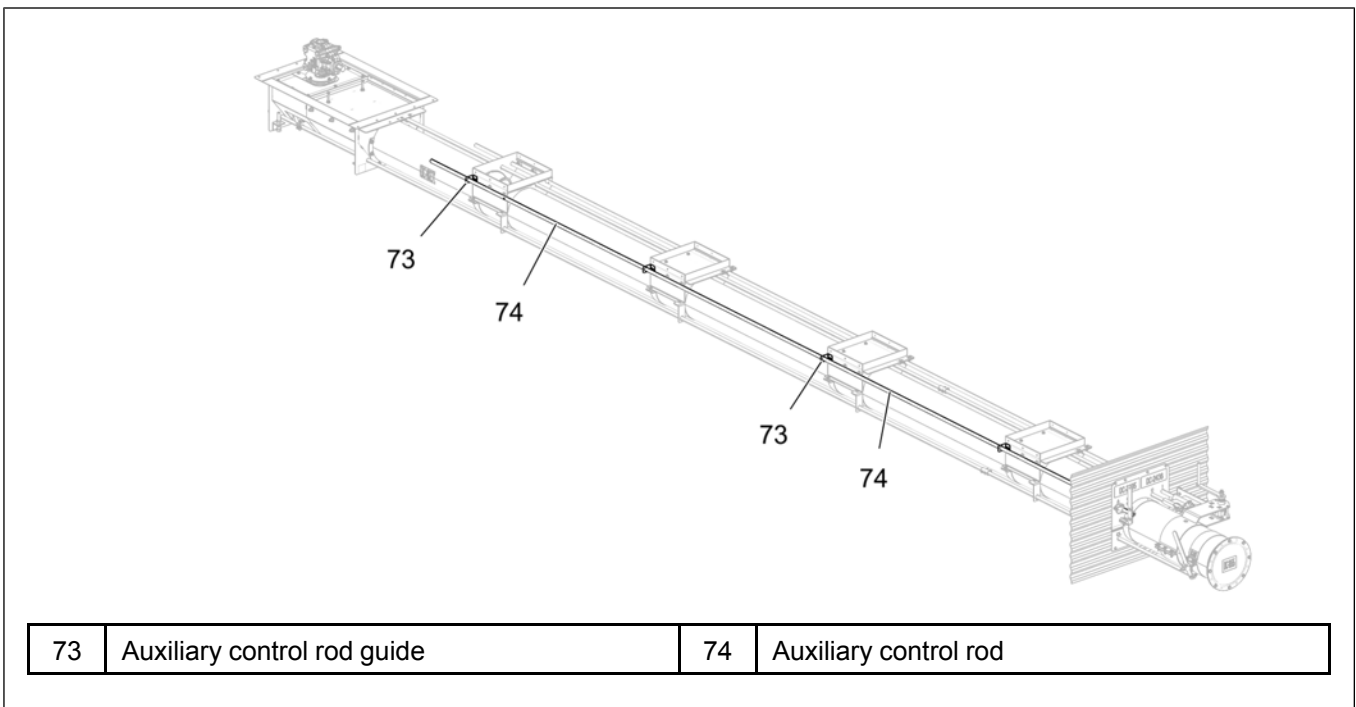

4. Install the auxiliary gate (70) using the flange bolts (60) and serrated flange nuts (9). Install the gate clamp (12), carriage bolts (13), washers (14), nuts (9) and pin (15) at the outside of the intermediate well.

NOTE:

- Make sure to provide gap in the intermediate well to install the bolts (60) and serrated flange nuts (9) in the auxiliary gate before closing.
- Make sure to install the gate clamp (12), carriage bolts (13), flat washers (14), serrated flange nuts (9) and pin (15) to the auxiliary gate with the auxiliary control rod at the outside of the intermediate well.

IMPORTANT: Carriage bolts (13) must be installed from top down as shown, if not, they will interfere with the flooring and will not open.

Figure 3-13 Installing the auxiliary intermediate gate (for 10 in.)

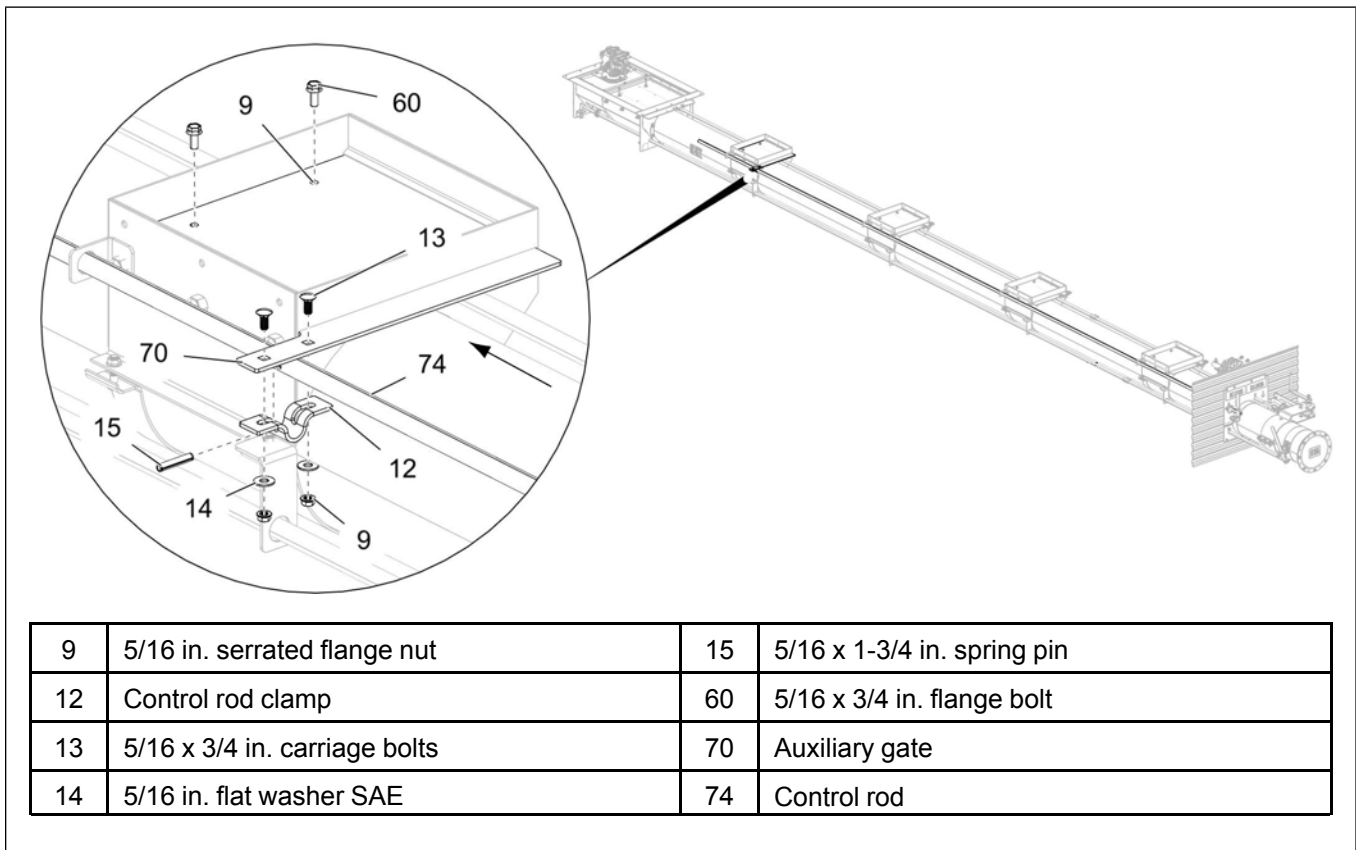

9	5/16 in. serrated flange nut	15	5/16 x 1-3/4 in. spring pin
12	Control rod clamp	60	5/16 x 3/4 in. flange bolt
13	5/16 x 3/4 in. carriage bolts	70	Auxiliary gate
14	5/16 in. flat washer SAE	74	Control rod

Chapter 3: Installation

5. Insert the auxiliary well lock collar (75) onto the auxiliary control rod (74) and install to the bin flange using carriage bolts (13) and serrated flange nuts (9).

Figure 3-14 *Installing the auxiliary well lock collar to bin flange*

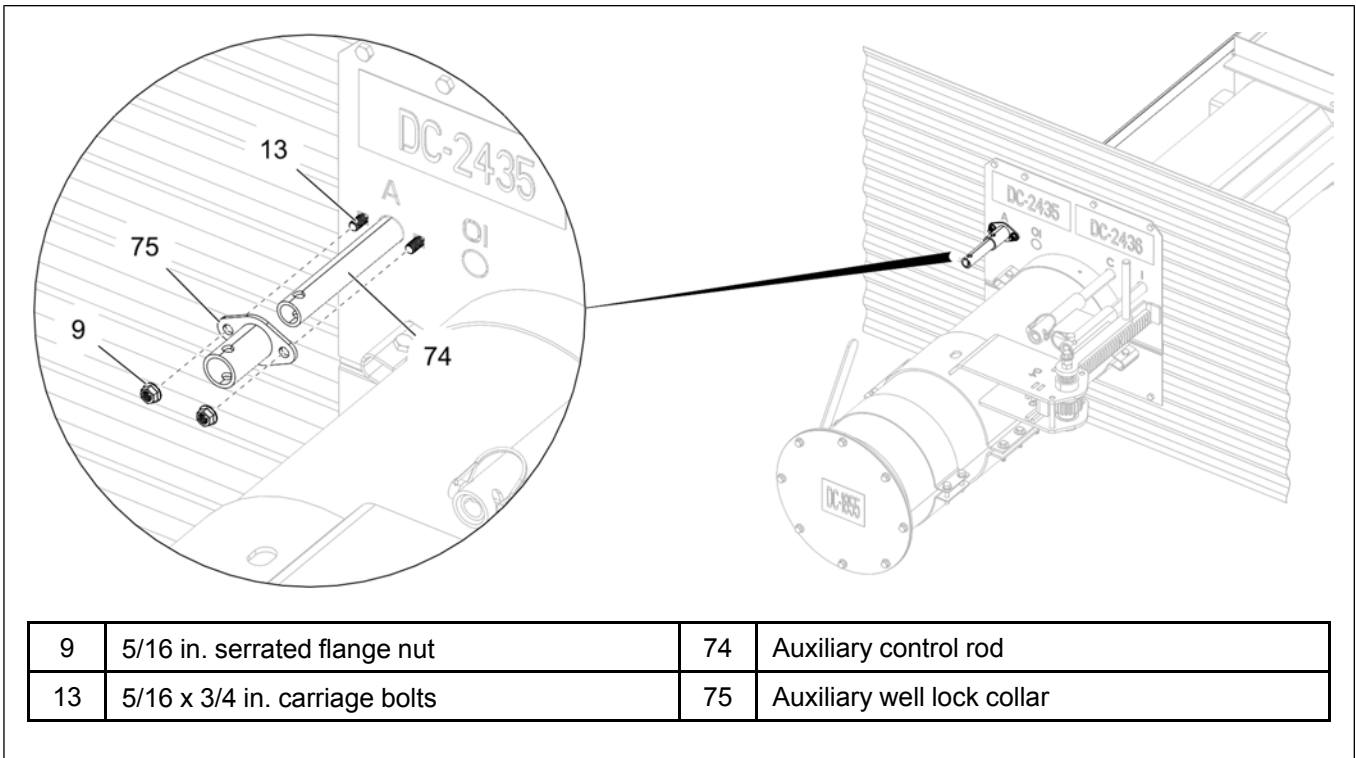

6. Insert the lock pin (16) through the auxiliary lock collar (75) and auxiliary control rod (74).

NOTE: Make sure the auxiliary well gate is completely closed, drill a hole in the auxiliary control rod (74) using the auxiliary lock collar (75) as drilling guide to insert the lock pin (16).

Figure 3-15 Installing the lock pin

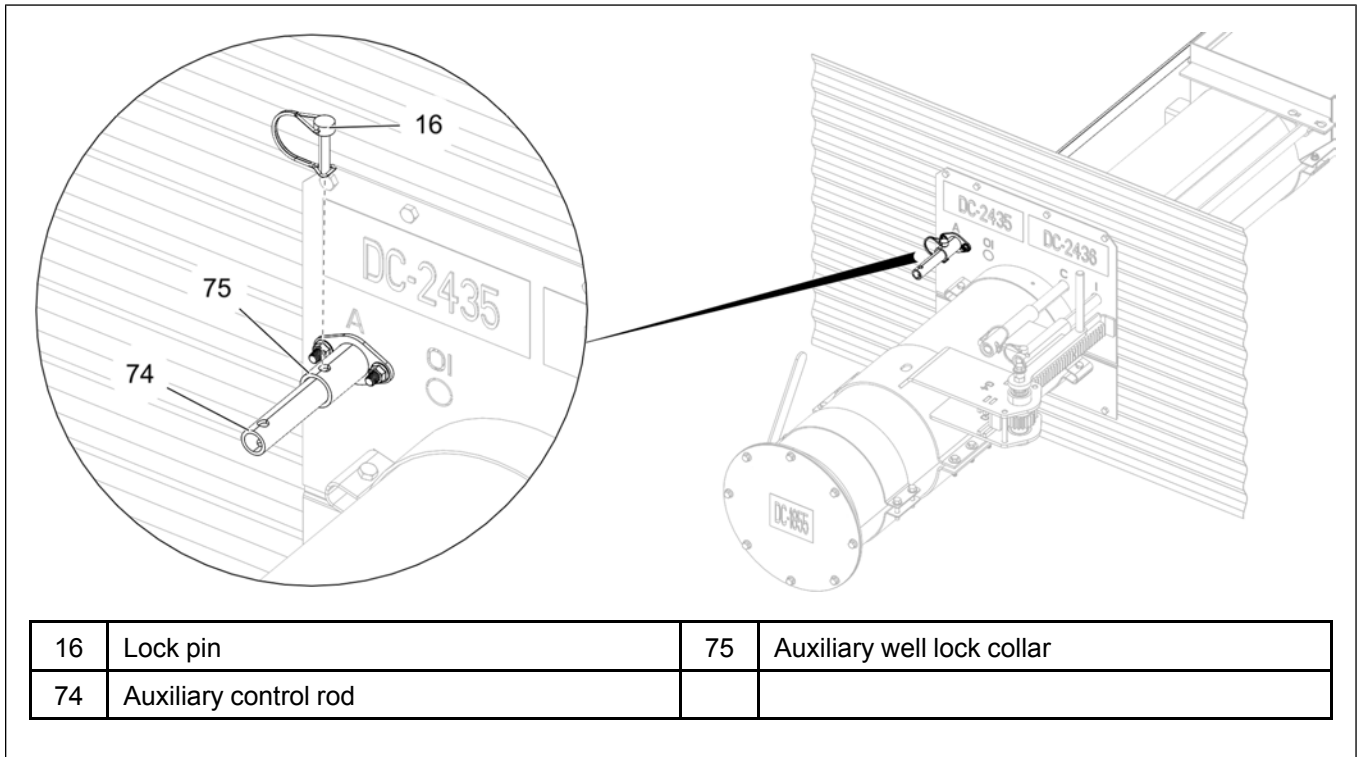

Chapter 3: Installation

7. Install the auxiliary control handle (76) to the auxiliary control rod (74) using carriage bolts (13), flat washers (14), serrated flange nuts (9) and pin (15).

Figure 3-16 Installing the auxiliary control lever (30 ft to 36 ft bins)

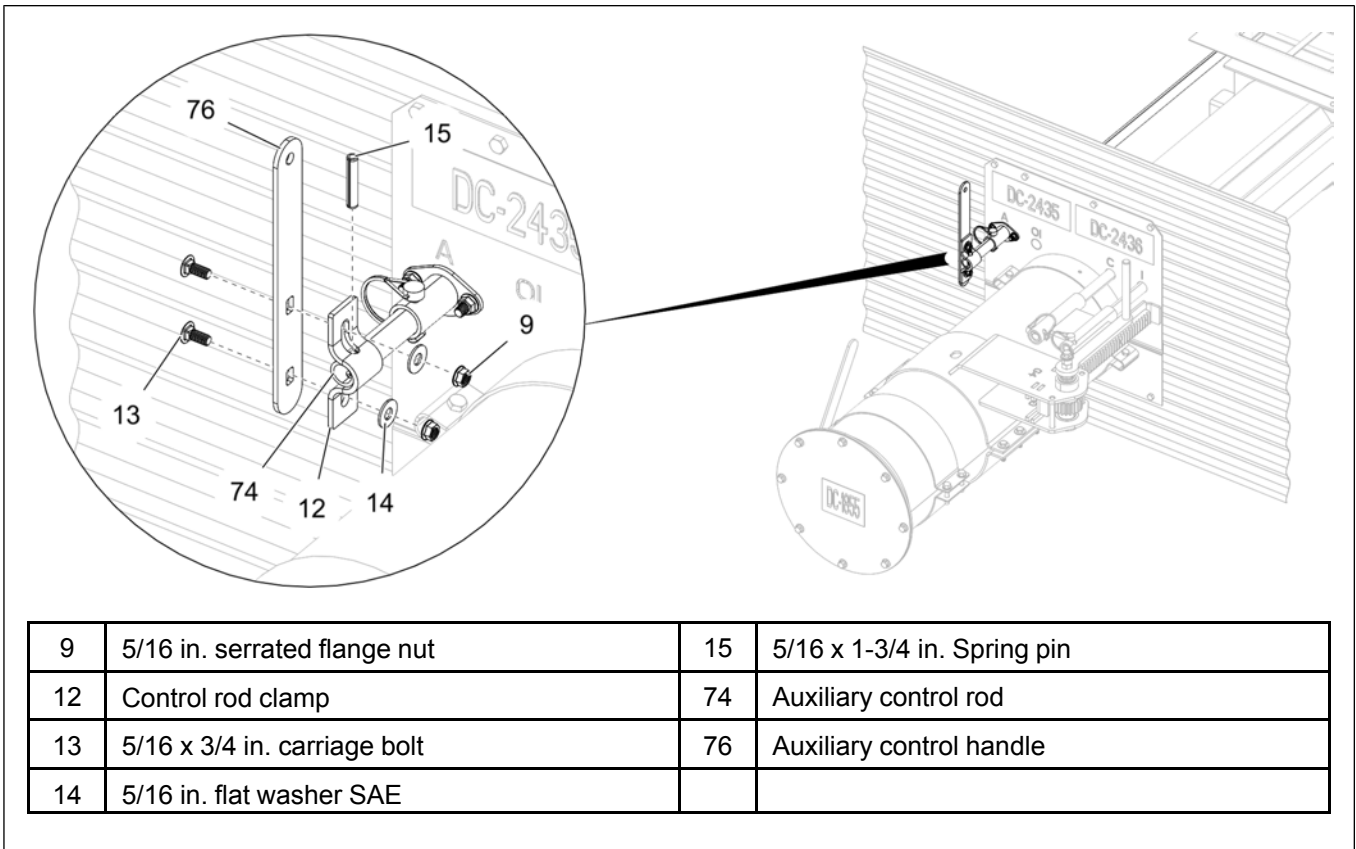

NOTE: For 42' diameter and larger bins, slide the auxiliary control rod to the rack and pinion and secure it with the safety snap-on pin. For details, see [Installing the Rack and Pinion, page 33](#).

Installing the Rack and Pinion

1. Make sure all gates are fully closed.
2. Slip the rack and pinion over center gate and intermediate control rods (17). Align holes, making sure rack and pinion is fully extended toward bin wall.
3. For double rack and pinion, slip one side over center gate and intermediate control rods (11 and 17) and the other side over the auxiliary and outside intermediate control rods (74 and 91). Align holes, making sure rack and pinion is fully extended toward bin wall.
4. With rack and pinion resting on unload tube and tube holes aligned, place the safety snap-on pins (16) through the center and intermediate well control rods (11 and 17) to the rack and pinion tubes (18) as shown.

Figure 3-17 *Installing the single rack and pinion (30 ft to 36 ft bins)*

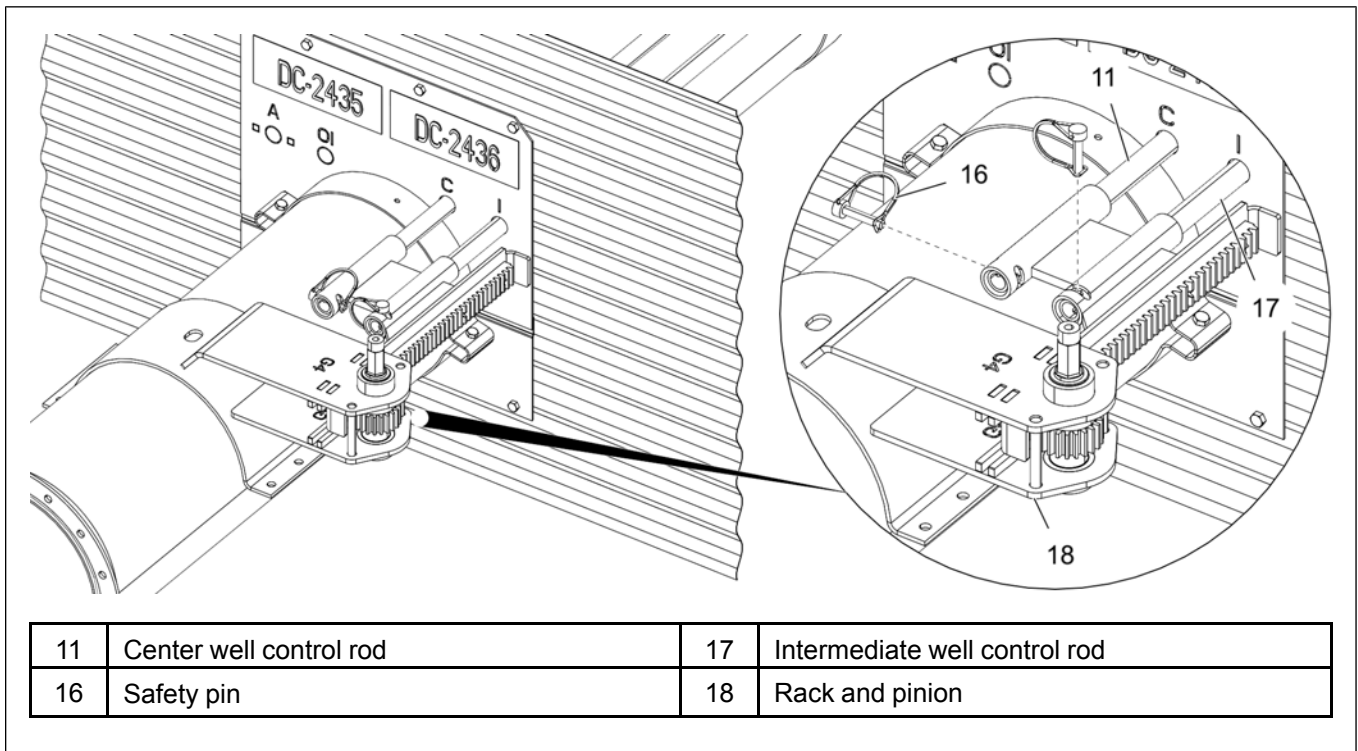

Chapter 3: Installation

5. With double rack and pinion (92) resting on unload tube and tube holes aligned, place the safety snap-on pins (16) to the rack and pinion tubes (18) through the center gate and intermediate well control rods (11 and 17) on one side and through the auxiliary and outside intermediate control rods (74 and 91) on the other side as shown.

NOTE: If there is no auxiliary control rod, do not place the safety pin.

Figure 3-18 Installing the double rack and pinion (42 ft bins and larger)

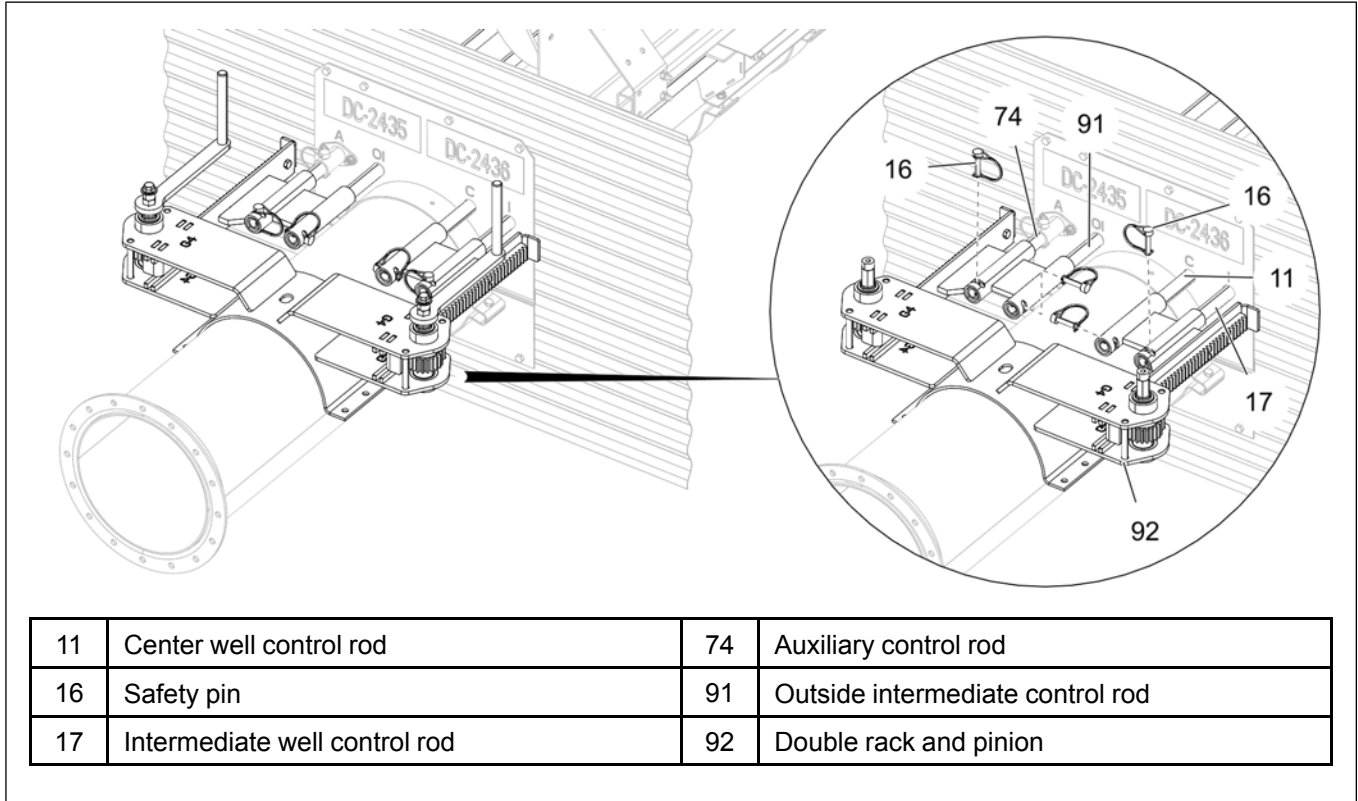

6. Slide the handle (34) over shaft on rack and pinion. Fasten down with serrated flange bolt (4) and flat washer (19).

Figure 3-19 *Installing the handle to single rack and pinion (30 ft to 36 ft bins)*

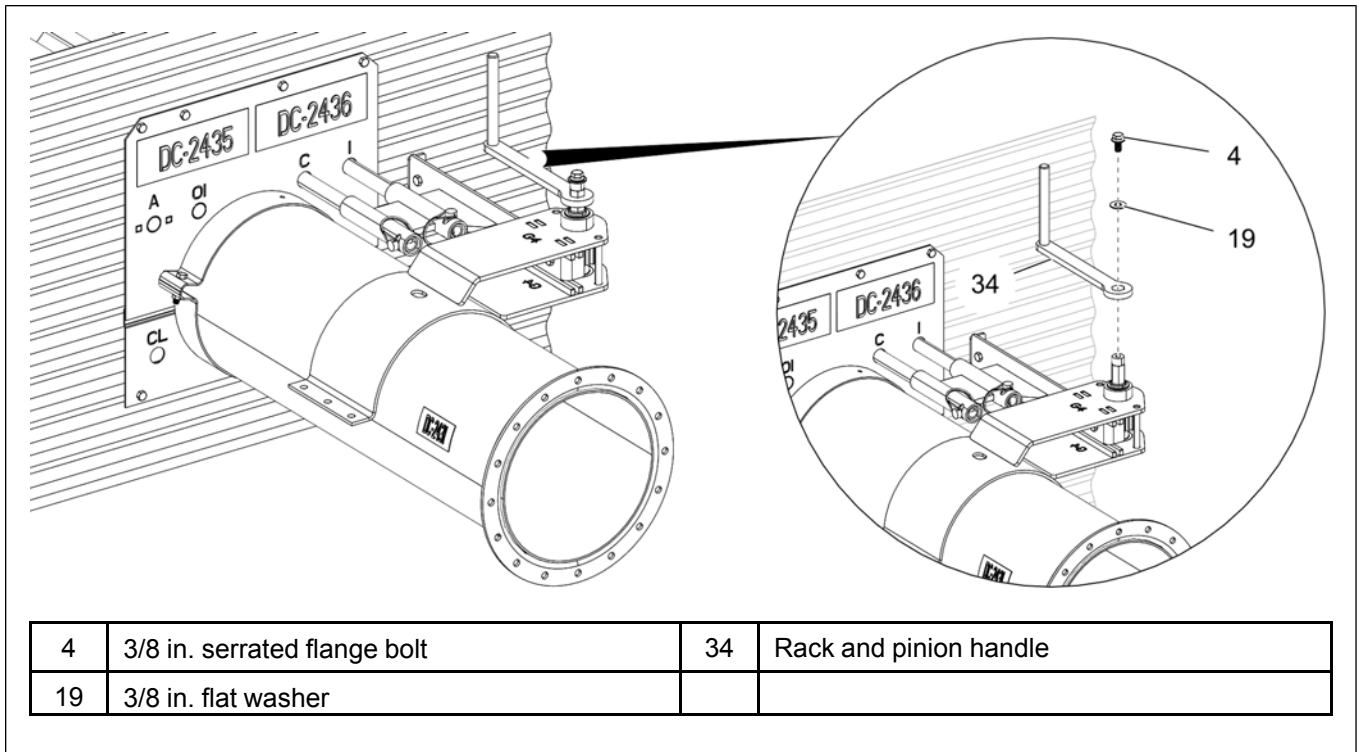

Chapter 3: Installation

- Slide a handle (34) over shaft at both sides on the double rack and pinion. Fasten down with serrated flange bolts (4) and flat washers (19).

Figure 3-20 *Installing the handles to double rack and pinion (42 ft bins and larger)*

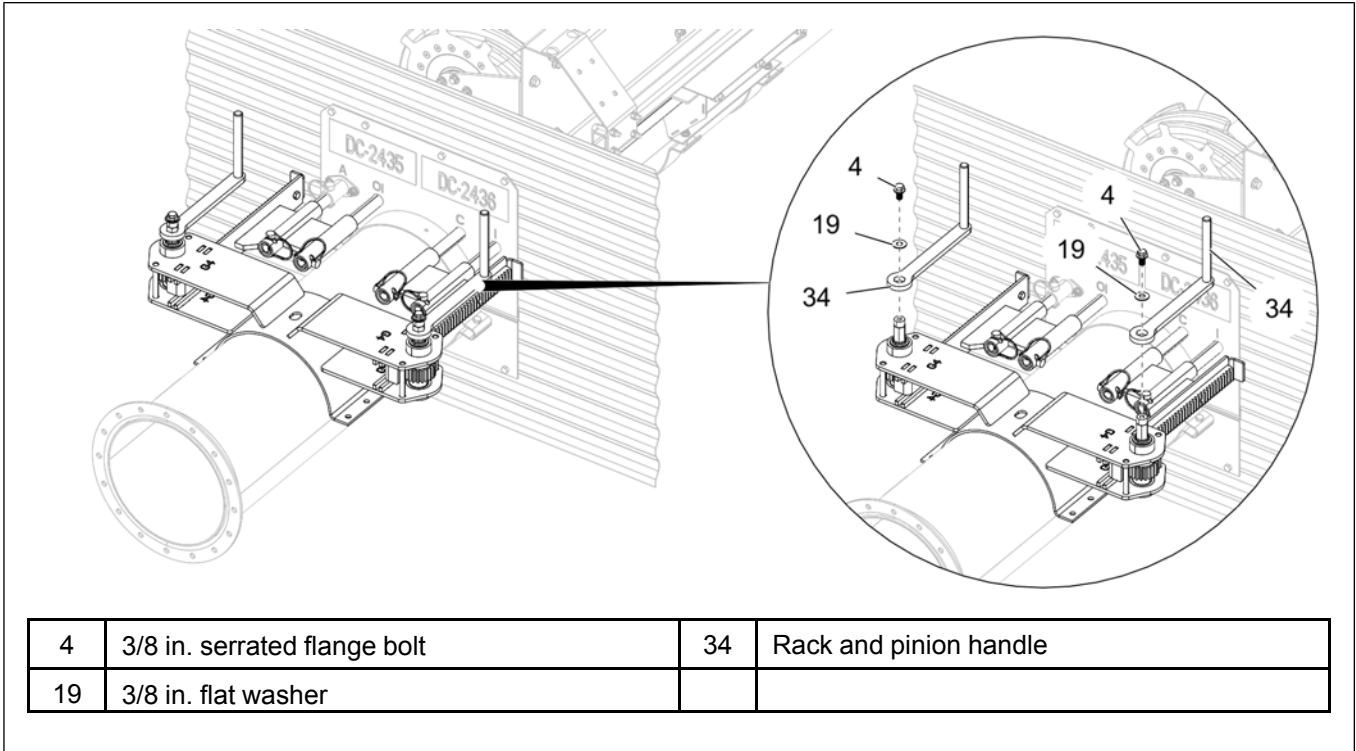

8. With rack and pinion fully extended towards the bin wall, attach lower half band (20) and secure to unload tube with HHCS bolts (8), flat washers (14) and serrated flange nuts (9).

Figure 3-21 Installing the lower half band

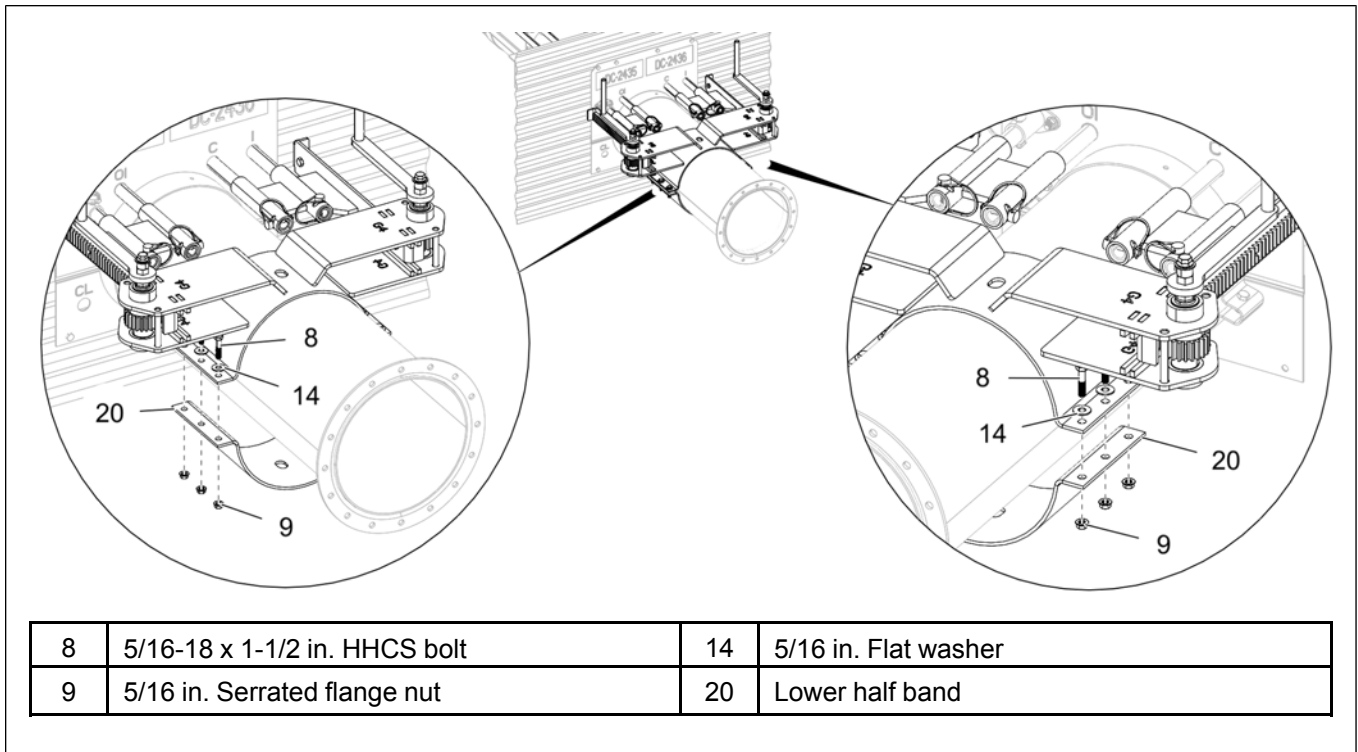

Installing the Clutch Control

1. Install the clutch control rod guides (23) to the left side of the intermediate well (65) using HHCS bolts (64) and serrated flange nuts (9).
2. Slide the clutch control rod (22) through the bin flange (6), rod guides (23) on the intermediate wells and through the back of center well.

Figure 3-22 Sliding the clutch control rod through support brackets

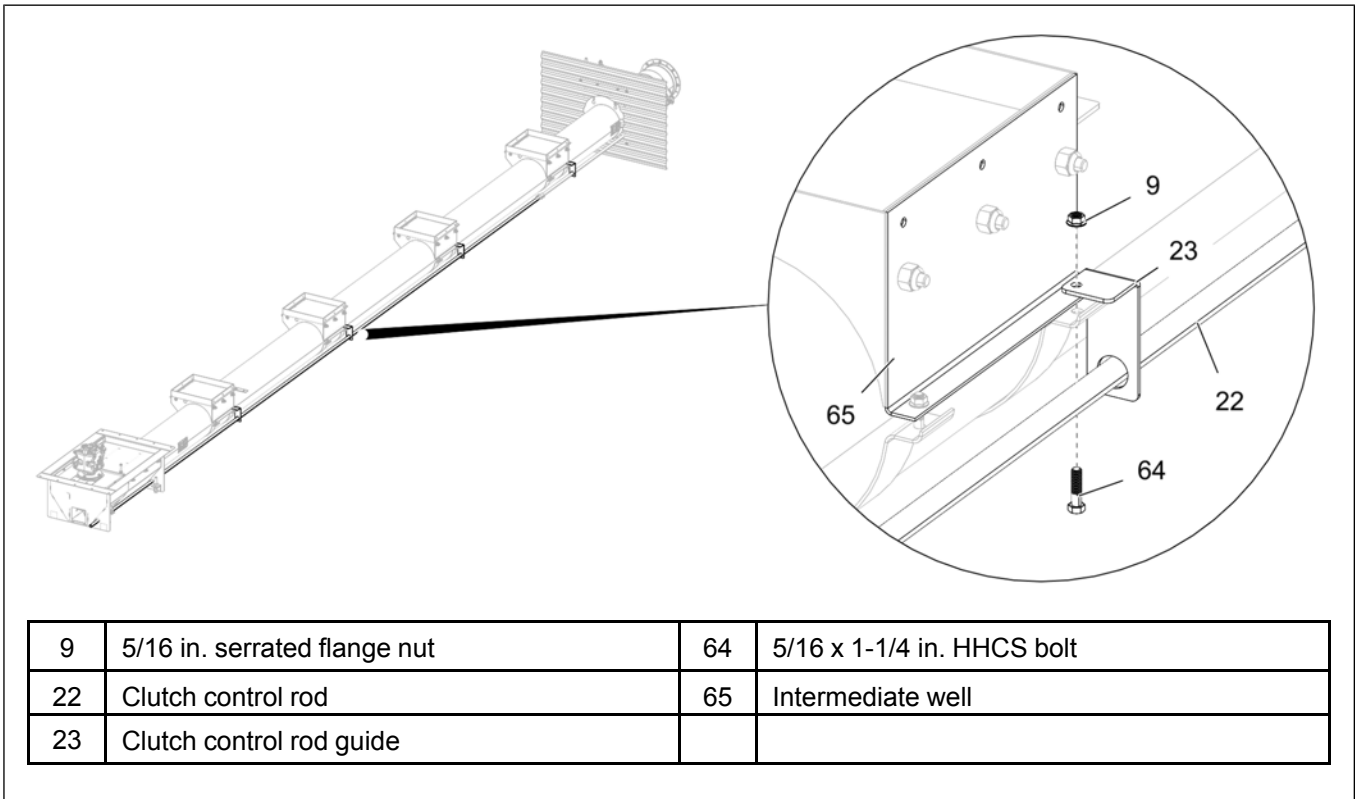

3. Bolt the clutch control rod to the center well linkage plate (24) using HHTB bolt (25), flat washer (14) and nylock nut (66).

NOTE: Make sure that bolt head is inside. Do not over tighten the nylock nut. The linkage plate should slide freely on bolt.

NOTE: The clutch control rod should slide freely and should not interfere with floor supports.

Figure 3-23 Installing the clutch control rod to center well linkage

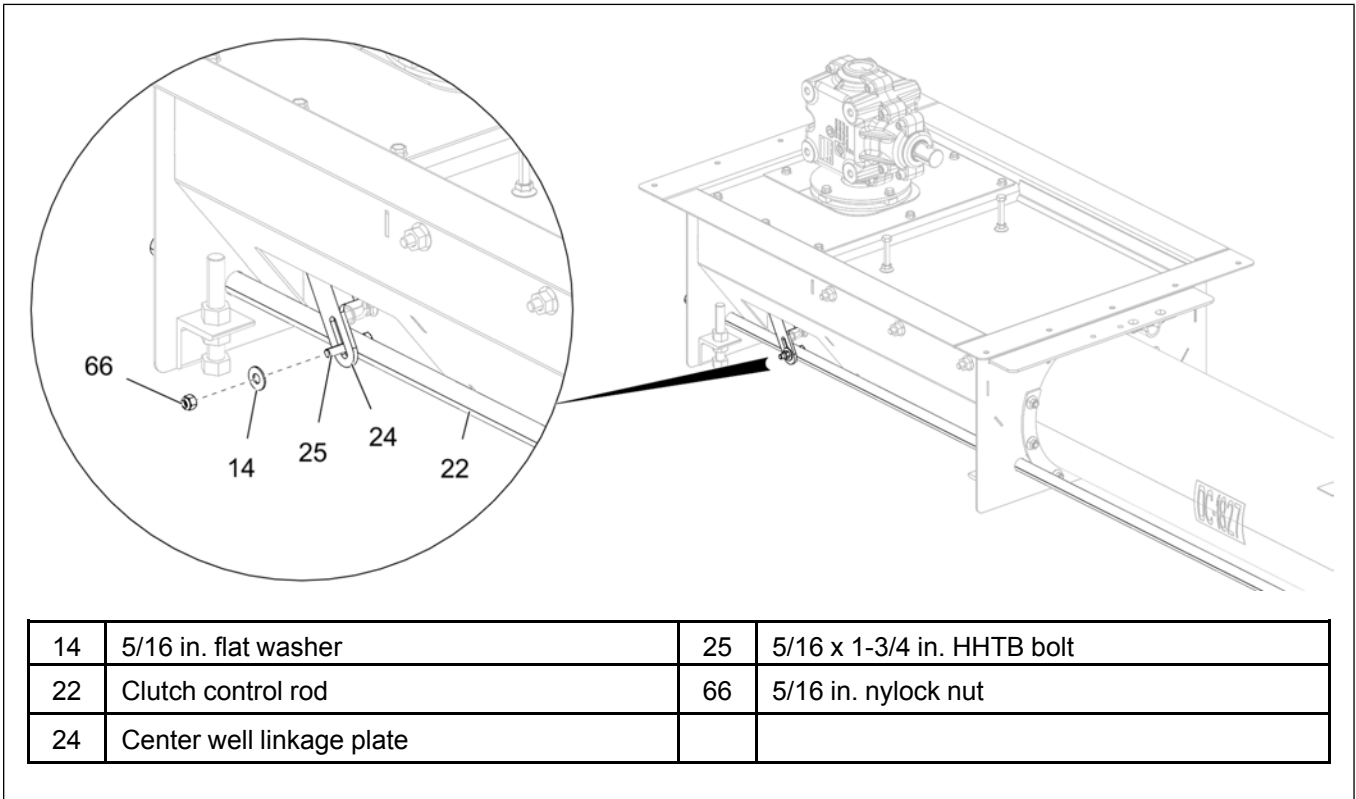

Chapter 3: Installation

- Attach the two clutch control rods (21 and 22) with a control rod coupler (67) using the HHTB bolts (25) and nylock nuts (66) as shown.

NOTE: The connecting rod coupler is used for sweeps in 42' diameter bins and larger.

Figure 3-24 Assembling the two clutch control rods

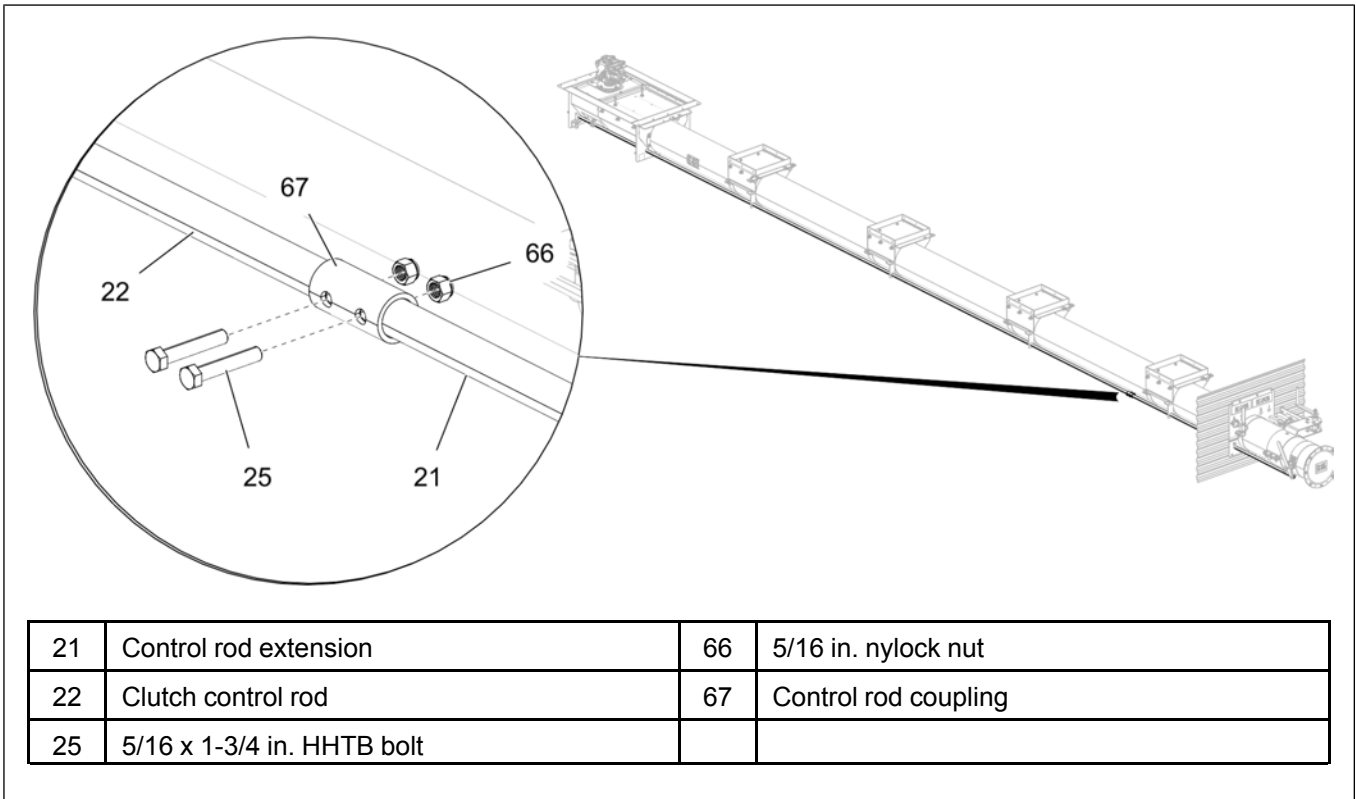

5. Attach the clutch handle (30) to pivot bracket (29) using HHCS bolt (26), nylock nut (85).

NOTE: Do not over tighten. Handle must pivot freely.

Figure 3-25 Attaching the clutch handle to pivot bracket

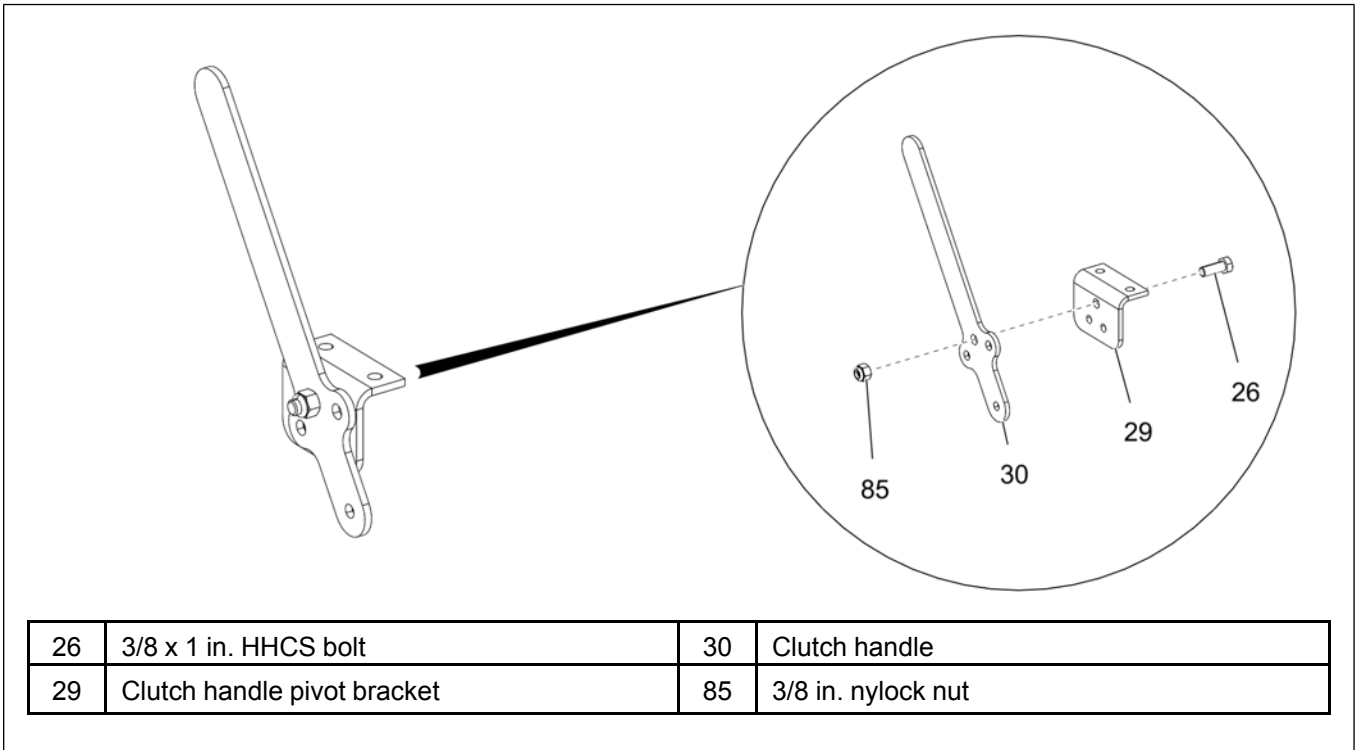

Chapter 3: Installation

- Attach the clutch pivot bracket (29) between the half bands (31). Secure the bracket with bands using flange bolts (27) and serrated flange nuts (9). Secure the bands together using flange bolts (28) and serrated flange nuts (9) on the other side.

NOTE: Clutch pivot bracket must be clamped tight between the half bands.

Figure 3-26 Attaching the clutch pivot bracket between the half bands

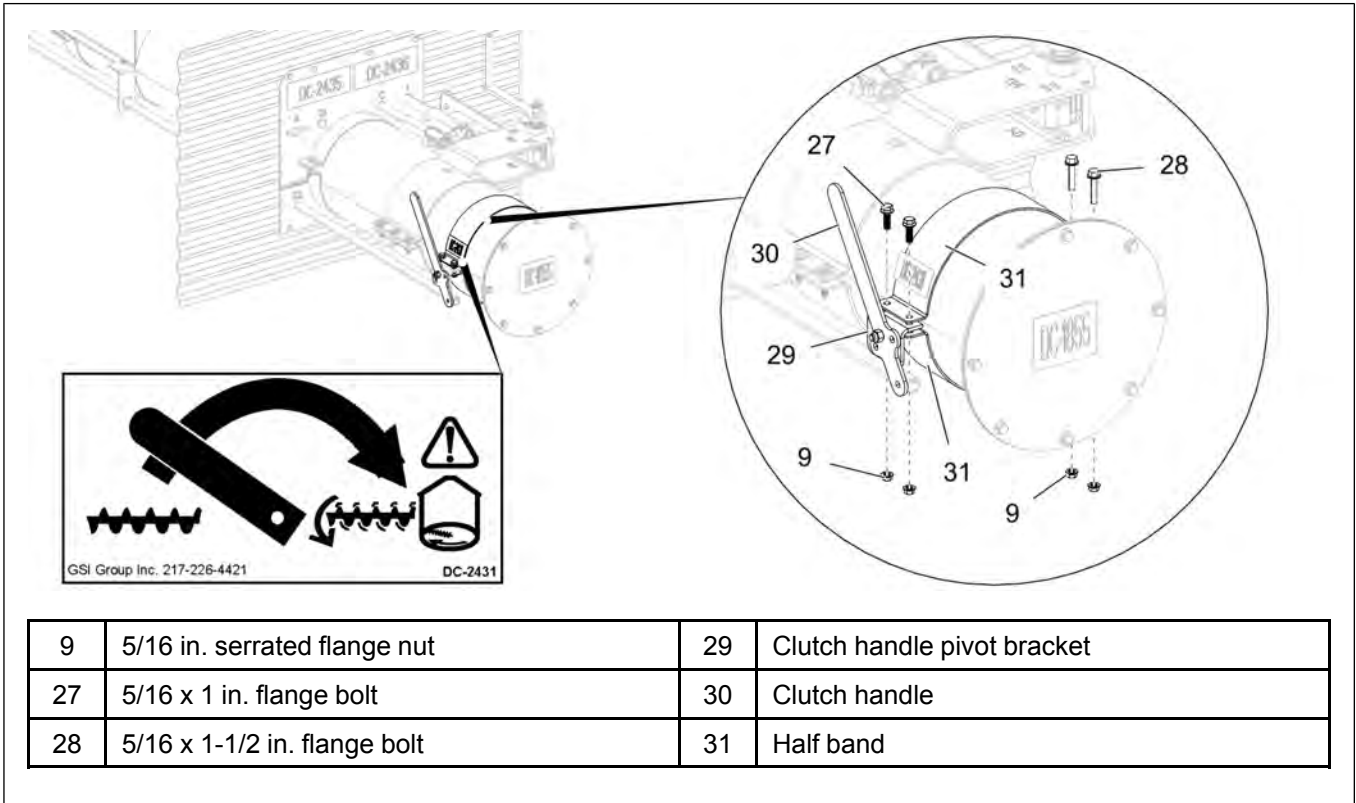

- 7. Insert the lock pin (16) through the disengaged holes in the clutch handle (30) and pivot bracket (29).

Figure 3-27 Inserting the lock pin

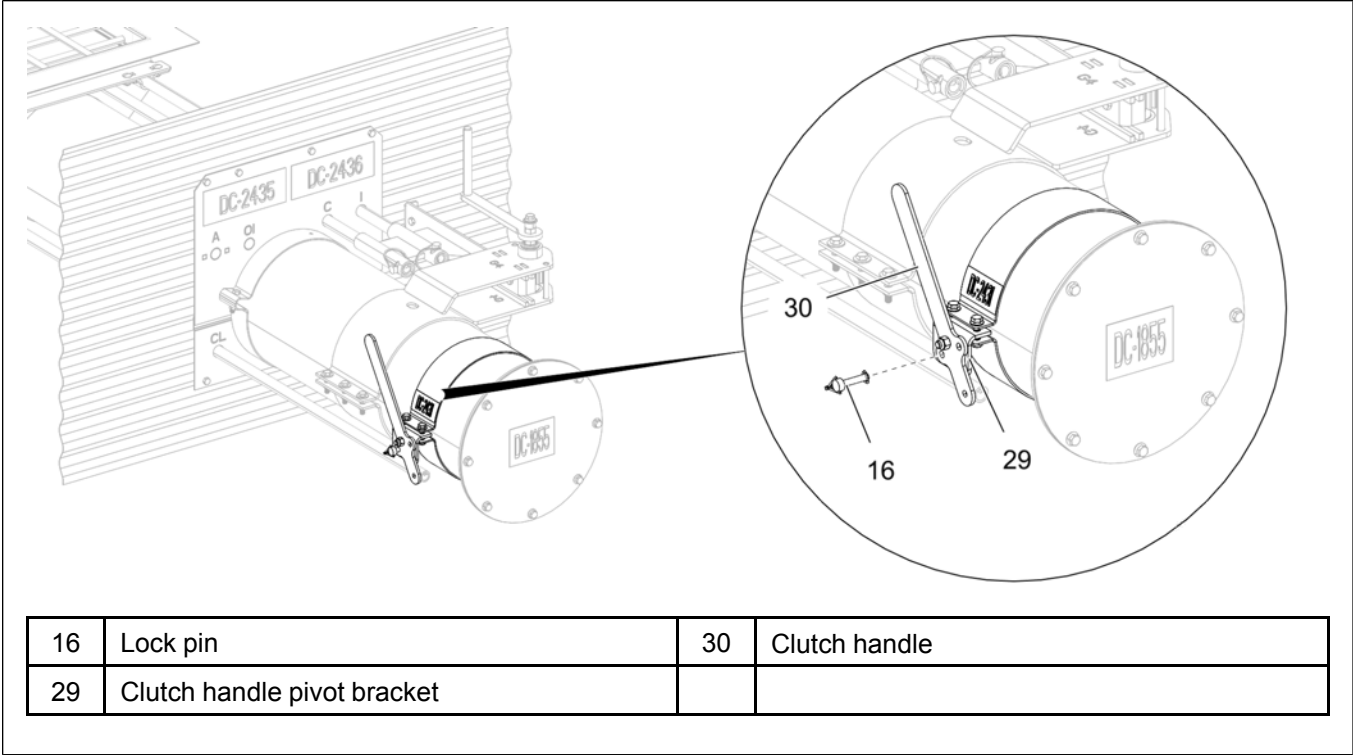

Chapter 3: Installation

- Attach the clutch handle (30) to the clutch control rod extension (21) using HHTB bolt (25) and serrated flange nut (9).

NOTE: Make sure the control rod is fully disengaged (pulled out) and the clutch handle is in disengaged position.

Figure 3-28 Installing clutch handle to clutch control rod

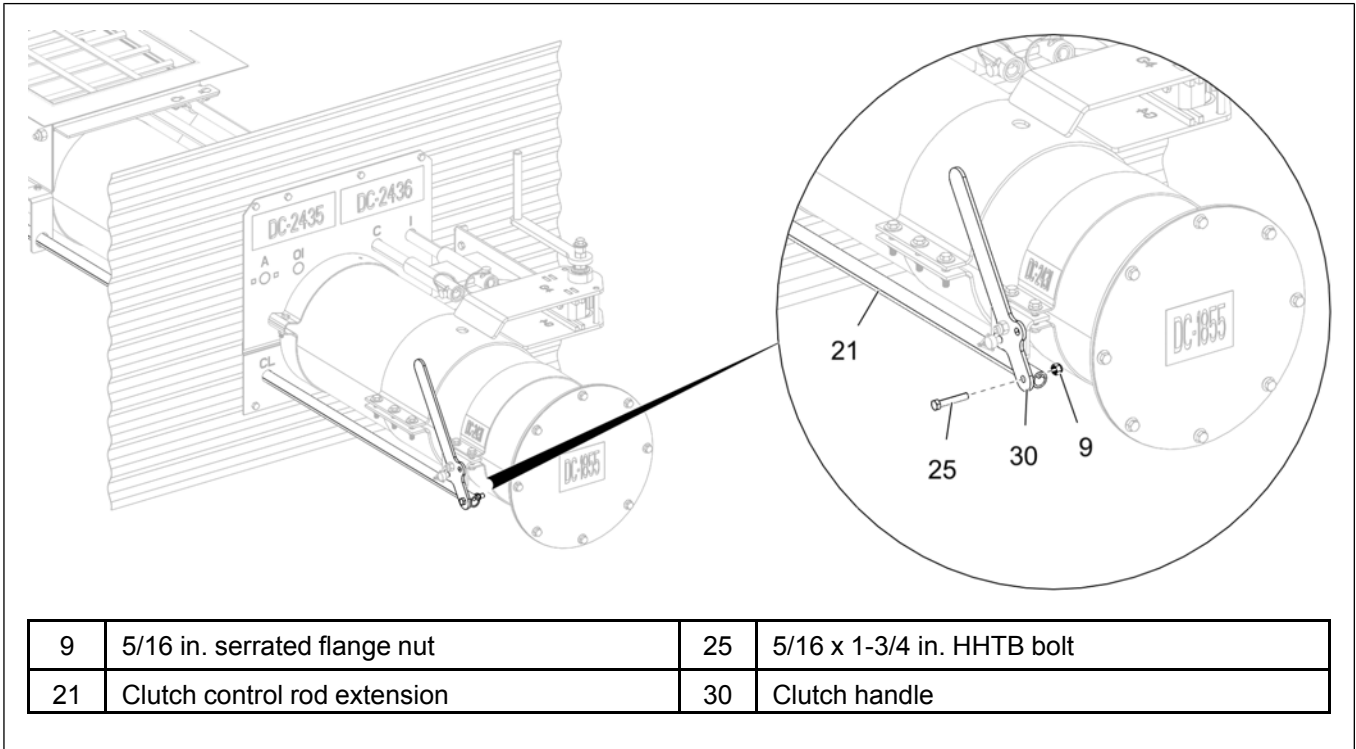

NOTE: Move the half bands on the tube as required to make necessary adjustments before locking the clutch in either disengaged or engaged position.

NOTE: Make sure to check the operation of the clutch rod by pulling the handle to engage the clutch and pushing the handle to disengage it.

Figure 3-29 Clutch positions

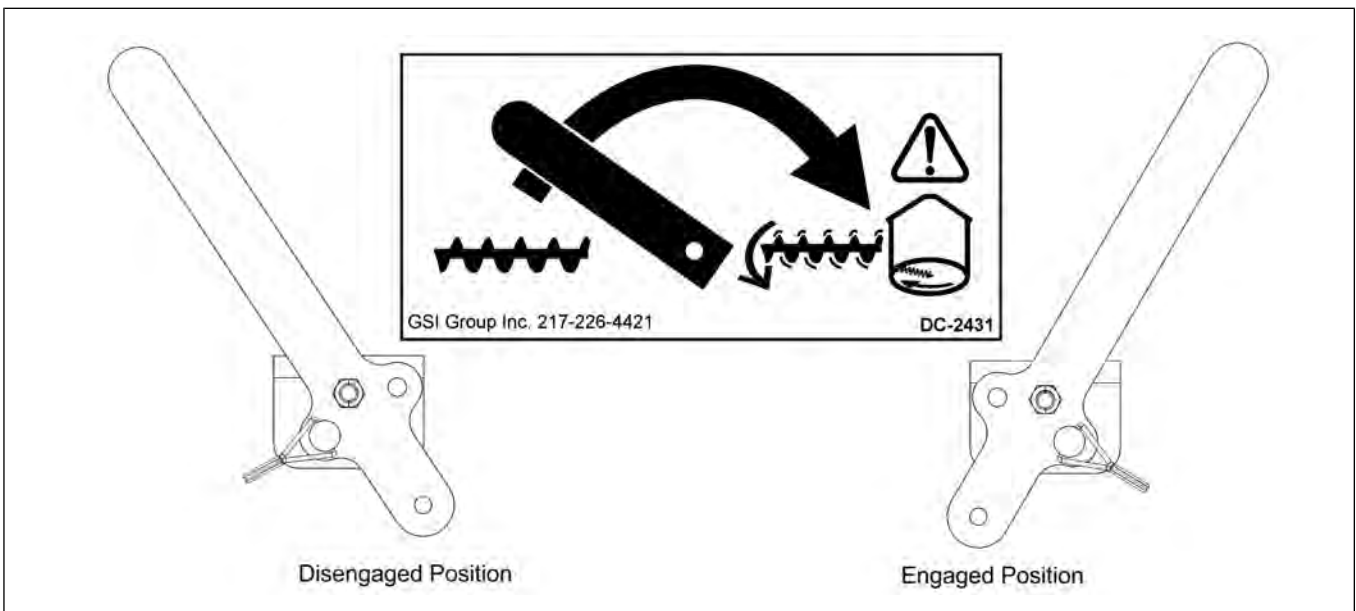

Installing the Unload Tube Flight

1. Begin by removing the tube end cap if you have not already done so.
2. Insert the flight (32) into the tube (2) with the square bushing end facing the center well and the round bushing end facing the discharge end of the tube.

Figure 3-30 *Installing the flight into unload tube*

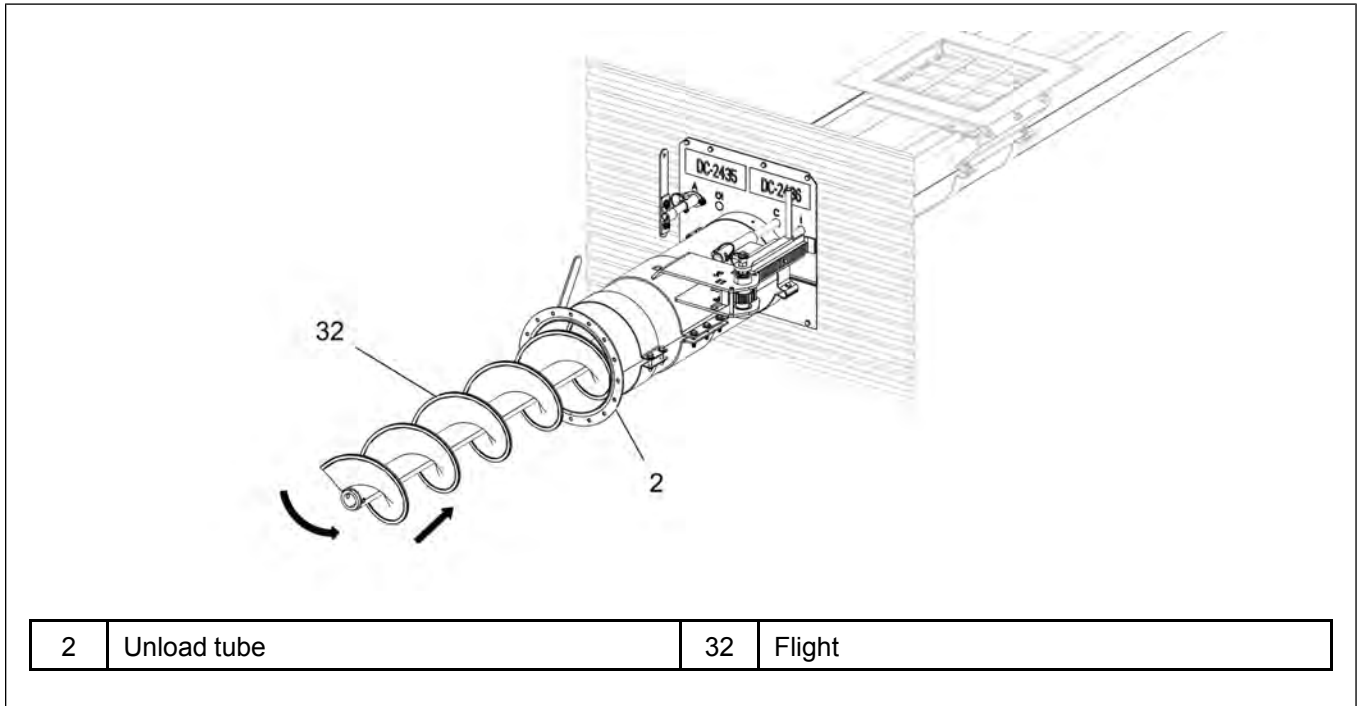

Chapter 3: Installation

3. When the flight (32) is approaching the center well shaft, it will be necessary to rotate the flight counter clockwise in order to get it to seat properly on the square shaft (33). When the flight is properly seated, the flight should be entirely inside the unload tube. It may be necessary to pull the flight out, a small amount and attempt this step multiple times in order to seat the flight properly.

Figure 3-31 Attaching flight to center well shaft

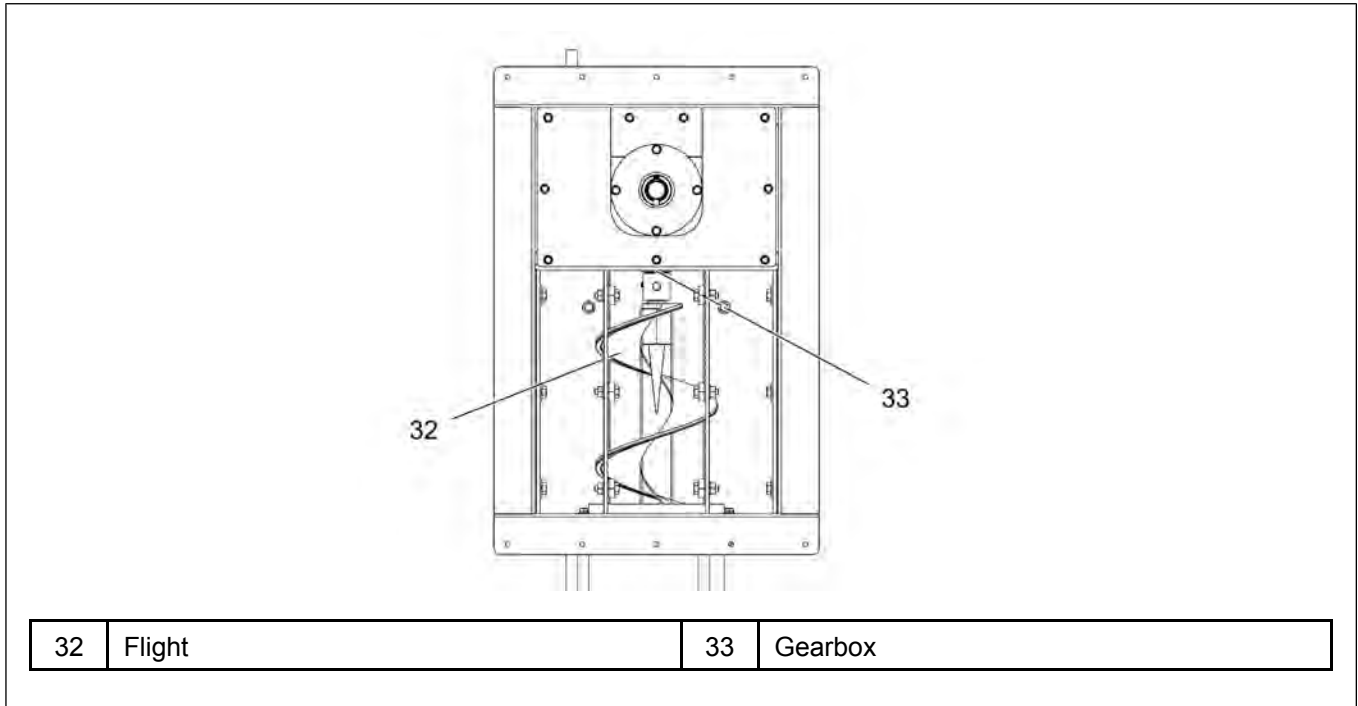

4. Open the center well gate and enter the bin to check and see that the flight is seated.

Installing Intermediate Well Flange

1. Place the intermediate well flange (77) onto the intermediate well.
2. Install self-drilling screws (13) to secure the intermediate well flange (77) to the bin floor.

Figure 3-32 *Installing the intermediate flange well*

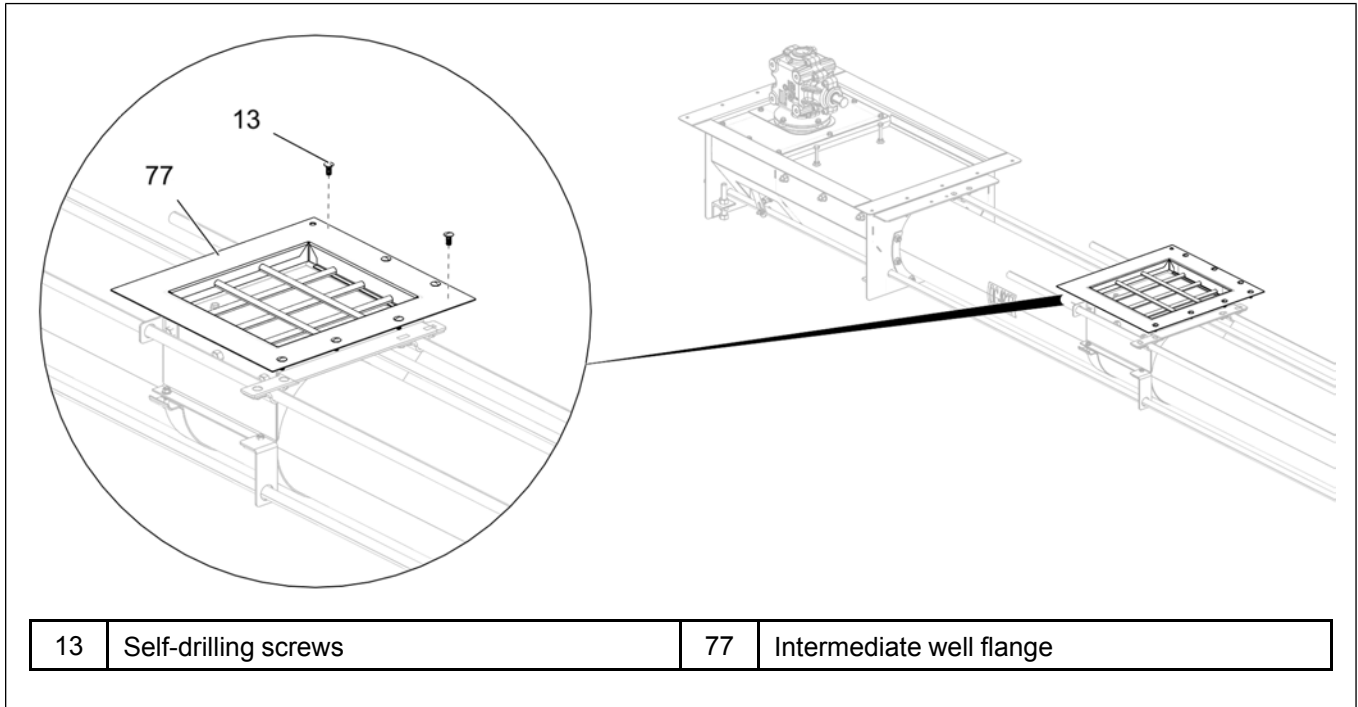

After You Finish

Repeat the above procedure to install the intermediate well flange in all the remaining intermediate wells.

Assembling the Sweep Flighting to the Backshield (60 Ft — 72 Ft Bins)

For sweeps up to 54 ft diameter bins, the sweep flighting is pre-assembled to the shield before being shipped. For sweeps above 60 ft diameter bins, the sweep flighting and the shield are not pre-assembled and will need to be assembled before installing them to the U-joint shaft attached to the gear box.

1. Attach the first hanger bracket assembly (82) to the backshield (99).
2. Slide the connecting shaft (95) into the hanger bracket assembly (82).
3. Attach the first flight section (98) to one end of the connecting shaft (95) using HHCS bolts (93) and stover nuts (94).

NOTE: Make sure to assemble the augers with the Dura-Edge on the grain side (discharge to the pivot) of the flighting.

Figure 3-33 Attaching the first flight section with hanger bracket to the backshield

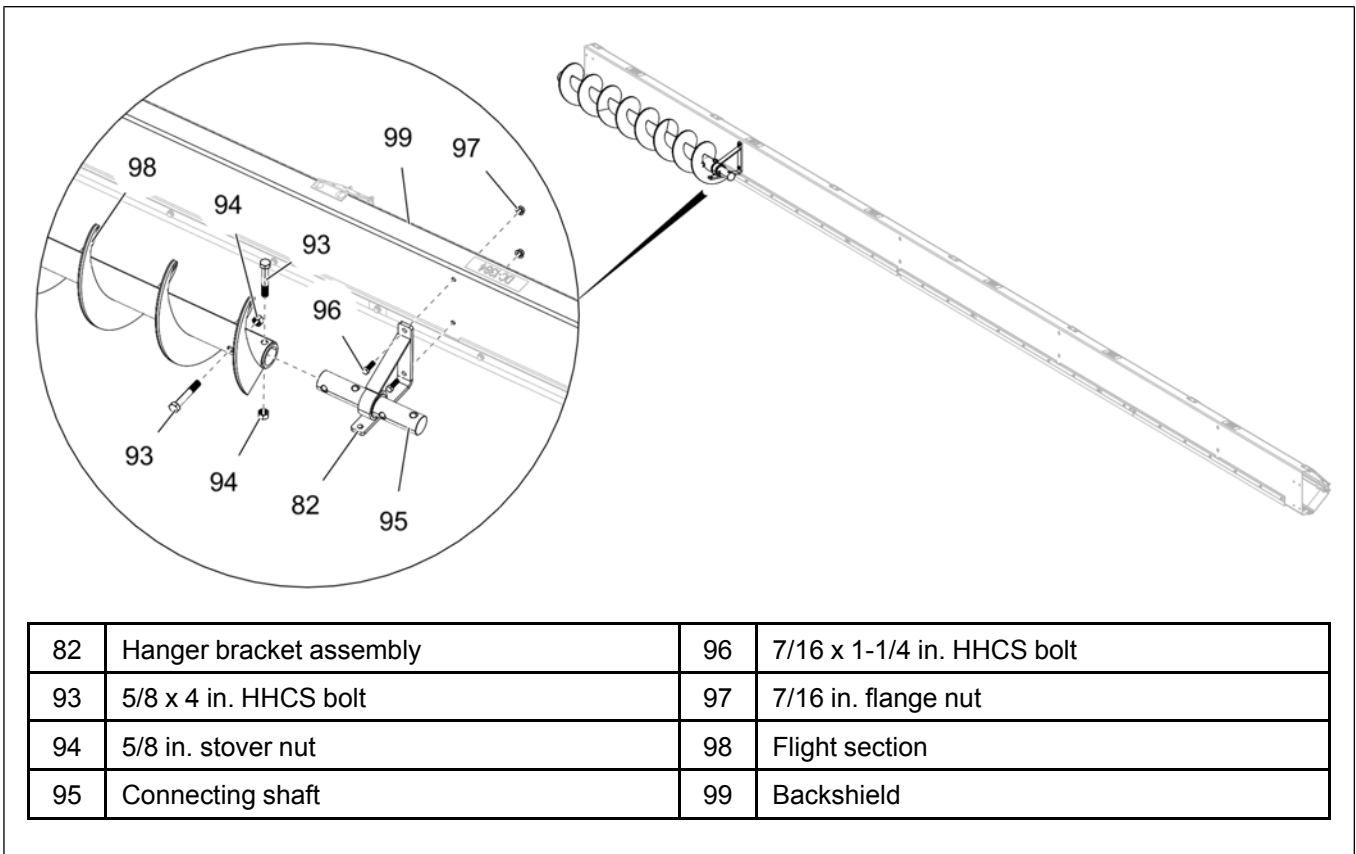

4. Attach the second hanger bracket assembly (82) to the backshield (99).
5. Slide the connecting shaft (95) into the hanger bracket assembly (82).
6. Attach one end of second flight section (98) to the connecting shaft (95) in the first hanger bracket assembly (82) and the other to the connecting shaft (95) in the second hanger bracket assembly (82) using HHCS bolts (93) and stover nuts (94).
7. Repeat the above steps to continue installing the remaining flight sections to the backshield.

Figure 3-34 Attaching the second flight section with hanger bracket to the backshield

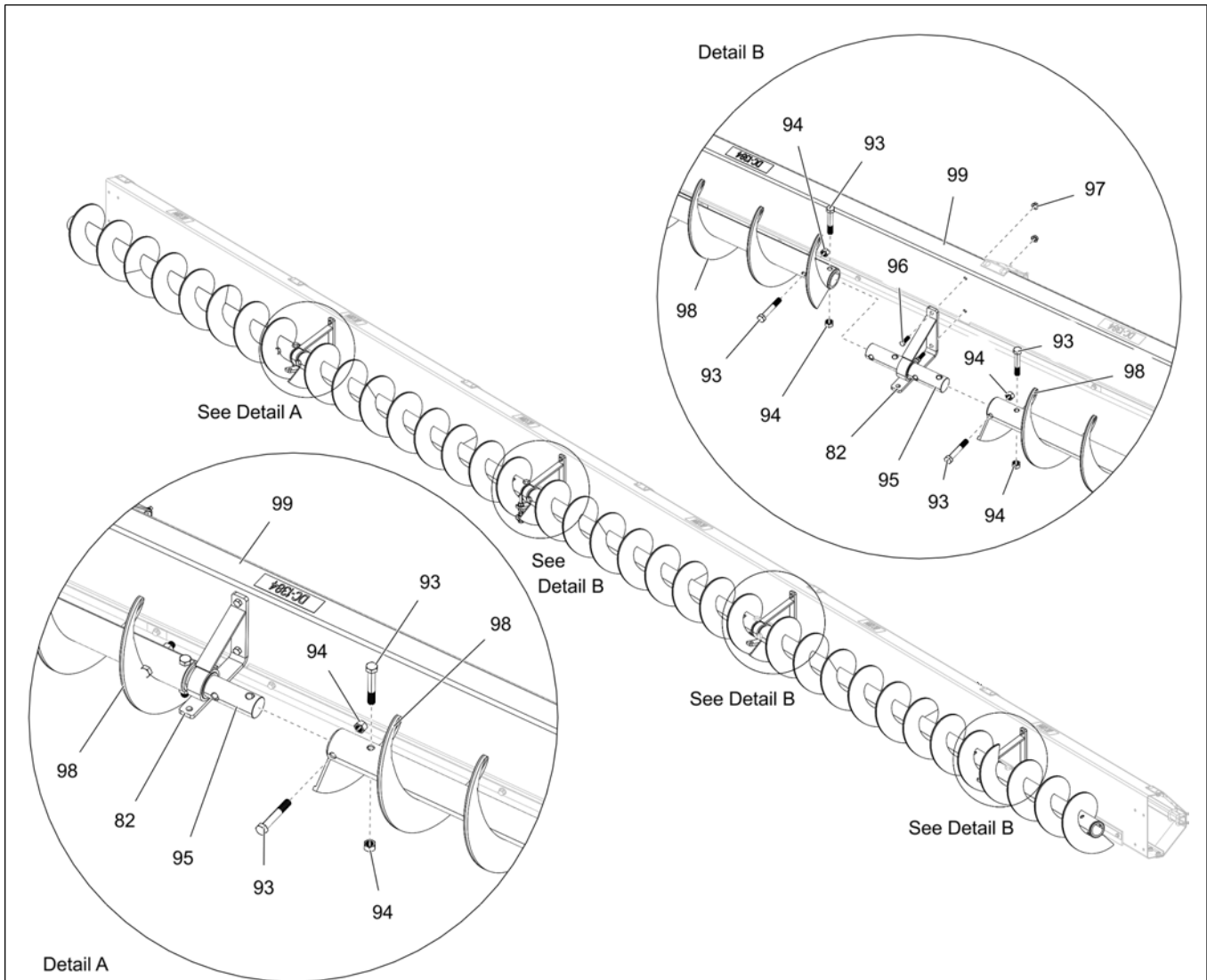

82	Hanger bracket assembly	96	7/16 x 1-1/4 in. HHCS bolt
93	5/8 x 4 in. HHCS bolt	97	7/16 in. flange nut
94	5/8 in. stover nut	98	Flight section
95	Connecting shaft	99	Backshield

Assembling the Sweep Support Skid

1. Attach the sweep support skid (83) to the hanger bracket assembly (82) using HHTB bolt (84), two flat washers (45), stover nut (37) and two flange nuts (100) at the front side of the shield.
2. Attach the sweep support skid (83) to the to the backshield using FHSCS bolt (101) and nylock nut (85) at the backside of the shield.

Figure 3-35 Assembling the Sweep support skid

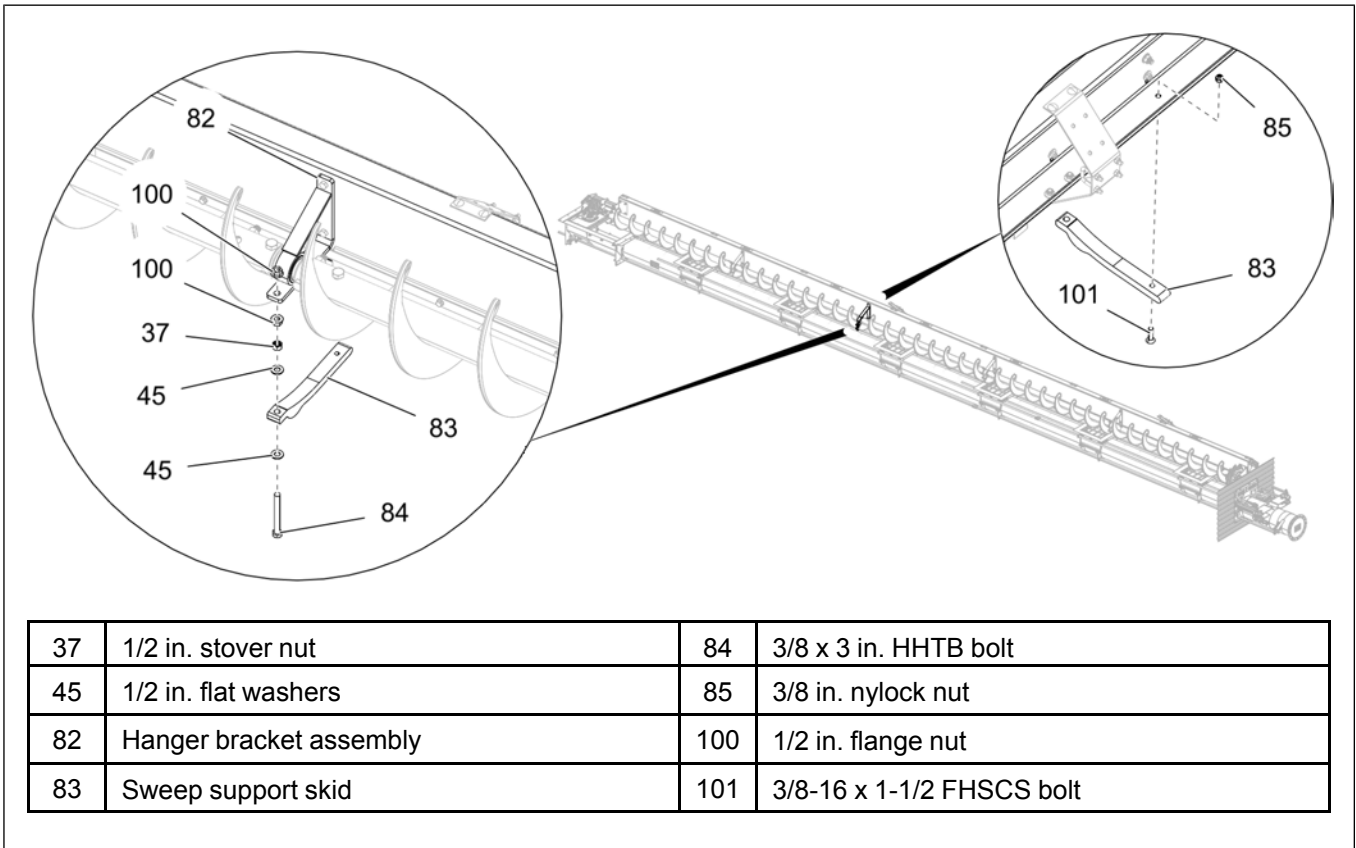

Installing the Sweep Flighting

1. Assemble the U-joint.

NOTE:

- Insert the stub (39) into the U-joint.
- Secure the U-joint (35) using a HHCS bolt (36), stover nut (37) and key (38).

Figure 3-36 Assembling the U-joint

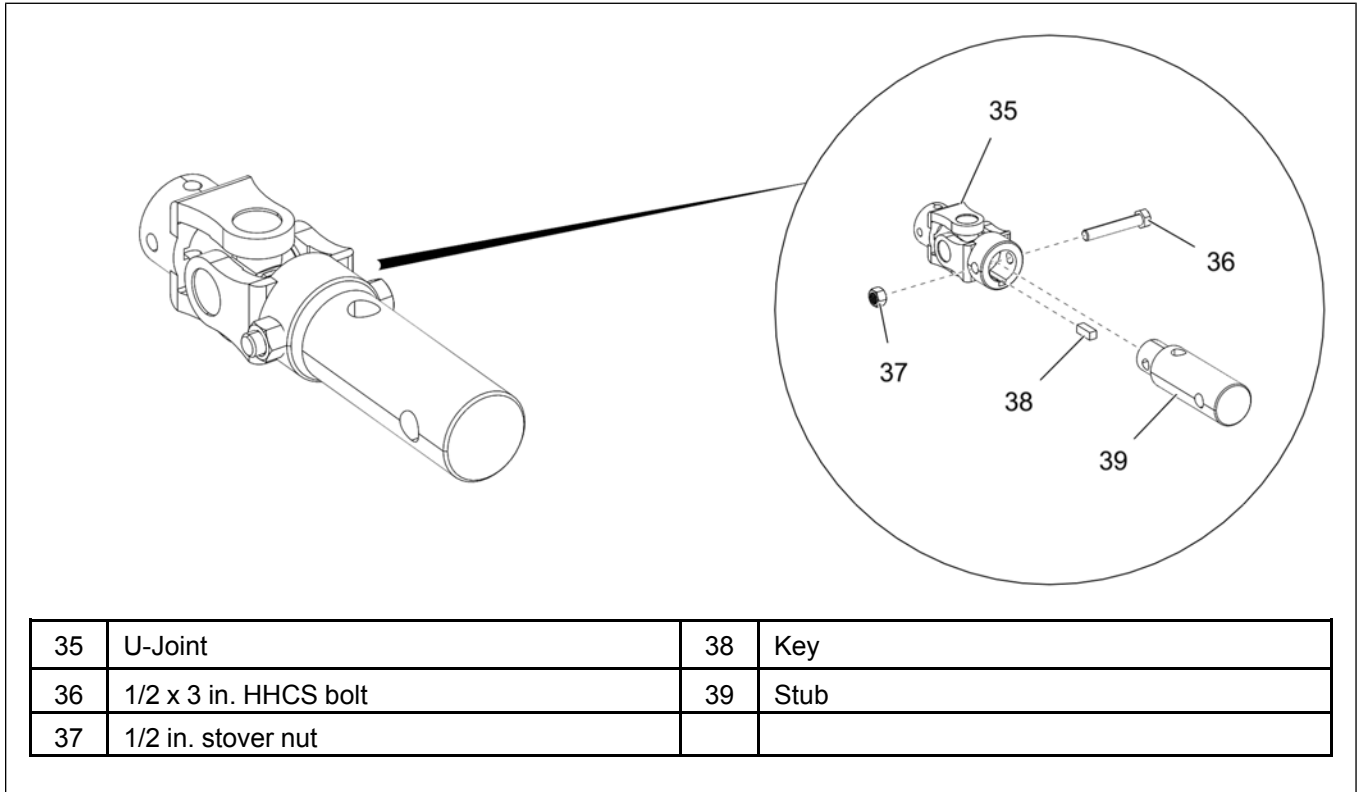

Chapter 3: Installation

2. Attach the U-joint.

NOTE:

- Slide the U-joint (35) onto the top gearbox (40) output shaft.
- Secure the U-joint using a HHCS bolt (41), stover nut (42) and key (90).

Figure 3-37 Attaching the U-joint to the gearbox

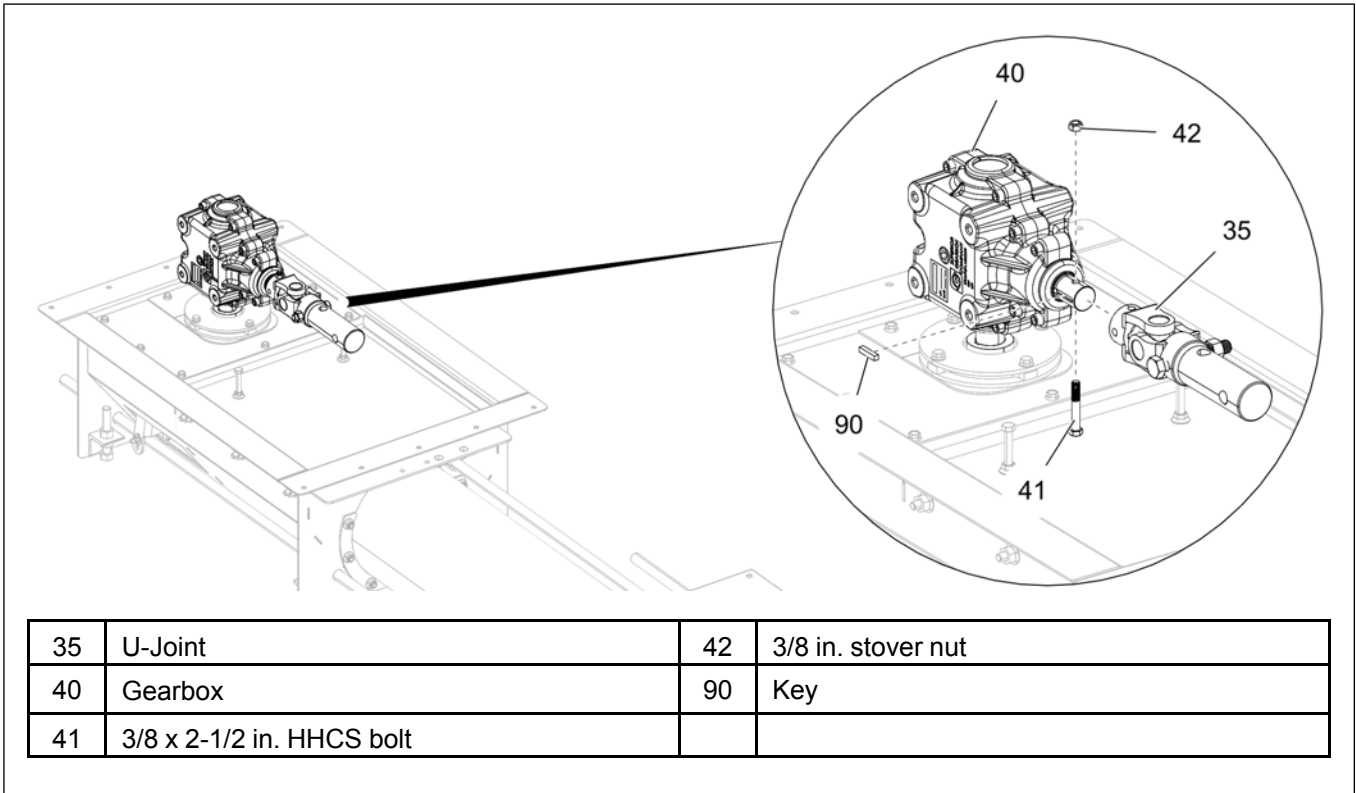

3. Attach the first auger section to the U-joint shaft (35). Making sure that the Dura-Edge® side of the flight (43) faces the center of the bin. Secure it with bolts (93) and stover nuts (94).

Figure 3-38 Attaching the auger to the U-joint

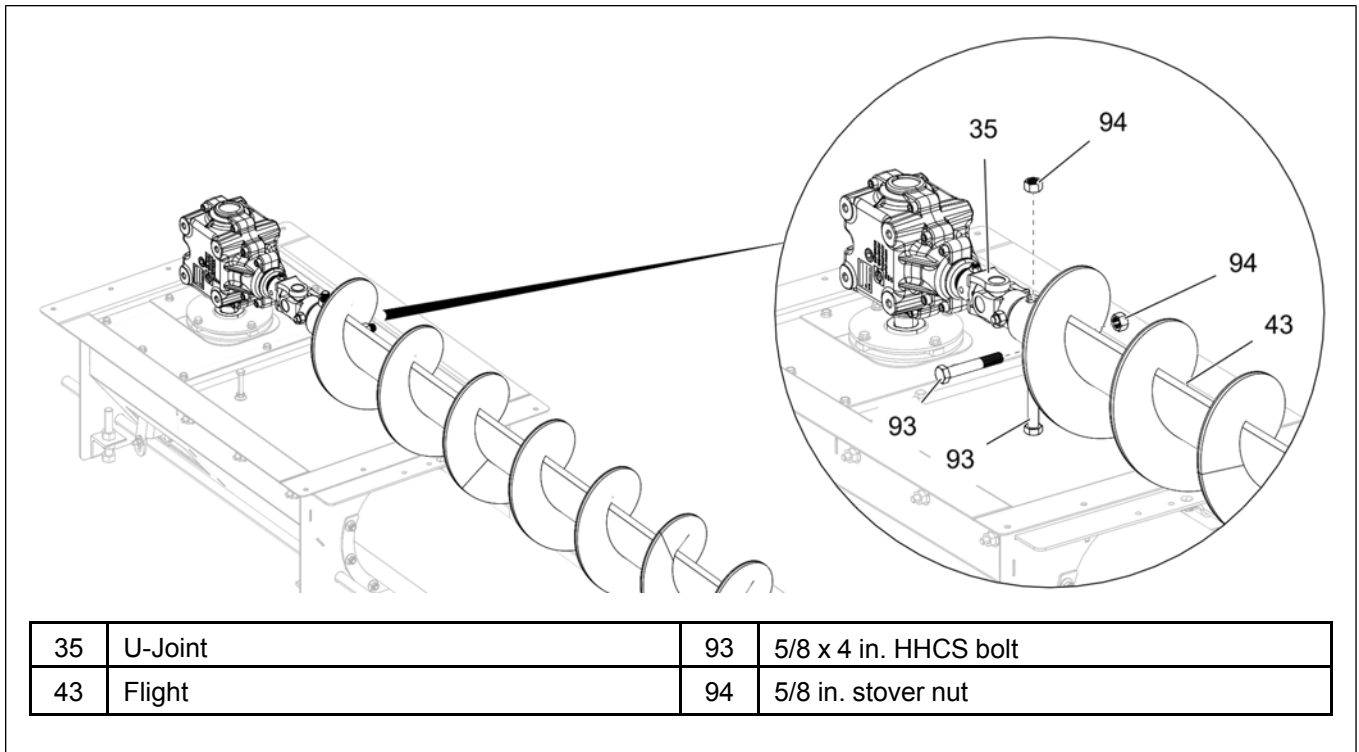

Chapter 3: Installation

4. Attach the pivot bracket (50) to the side of the gearbox using flange bolts (44) and flat washers (45).

NOTE: Do not tighten the bolts.

Figure 3-39 Attaching the pivot bracket to the gearbox

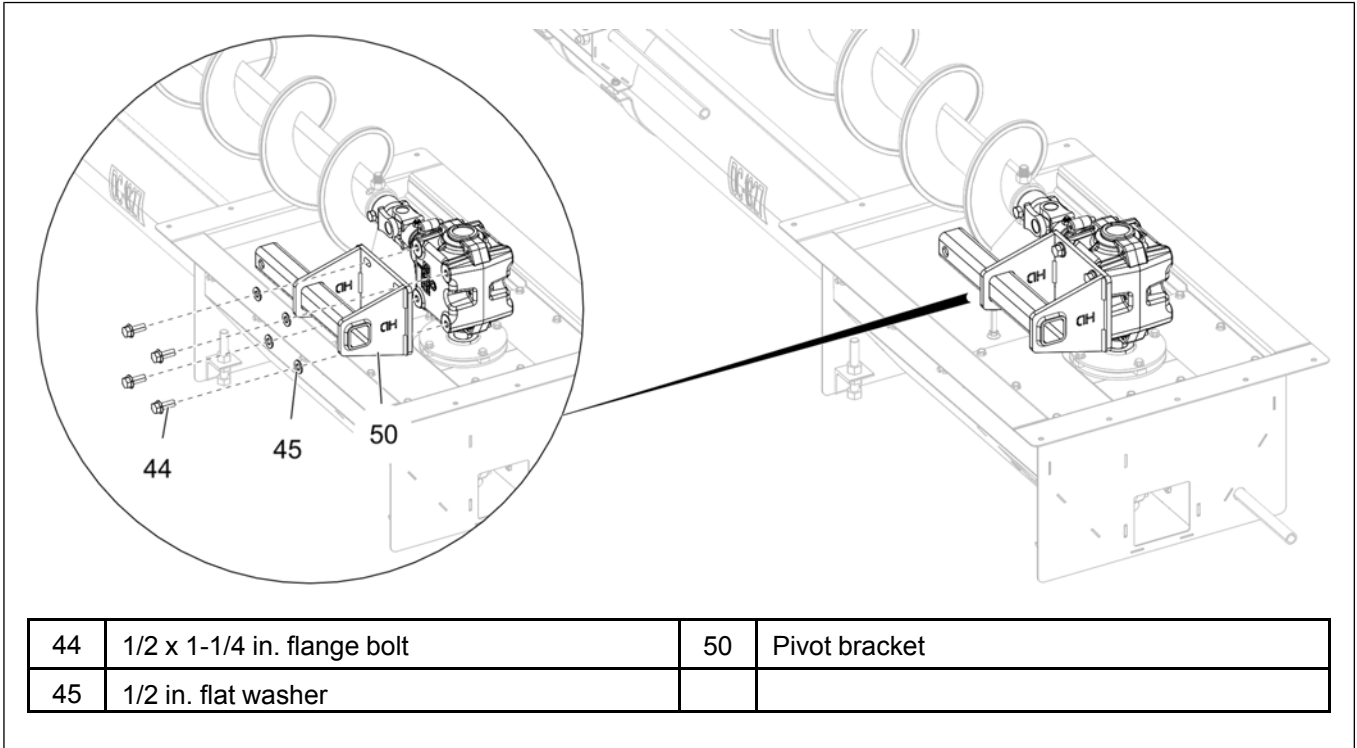

Installing the Flighting Shield

1. Assemble the flighting shield to the shield pivot bracket (49) using four flange bolts (51), and four flange nuts (5).

NOTE: Do not tighten the bolts.

Figure 3-40 Assembling the flighting shield to shield pivot bracket

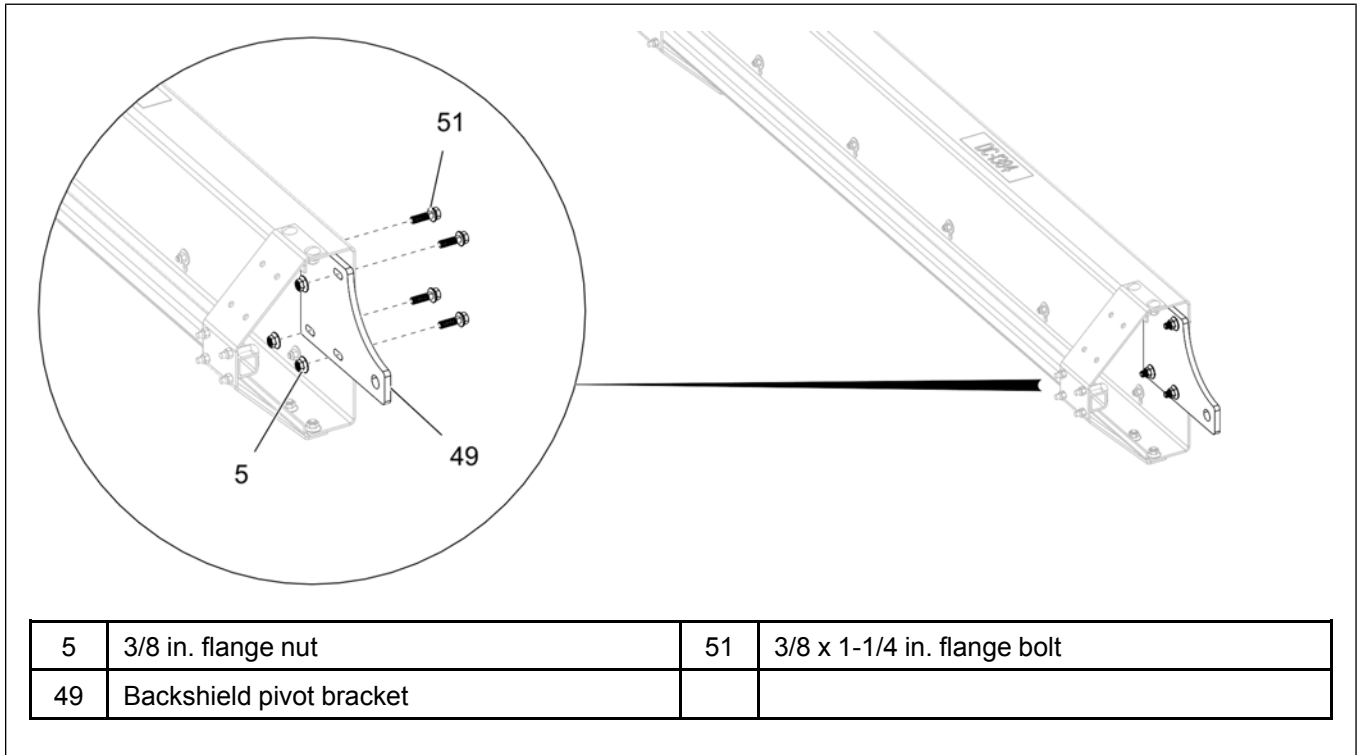

Chapter 3: Installation

2. Install the flighting shield pivot bracket assembly (49) to the pivot bracket (50) using a HHCS bolt (46), two flat washers (47) and a nylock nut (48).

NOTE: Do not tighten bolt (46) and nut (48). It should be snug-tighten to pivot freely.

Figure 3-41 Installing the flighting shield pivot bracket assembly to pivot bracket

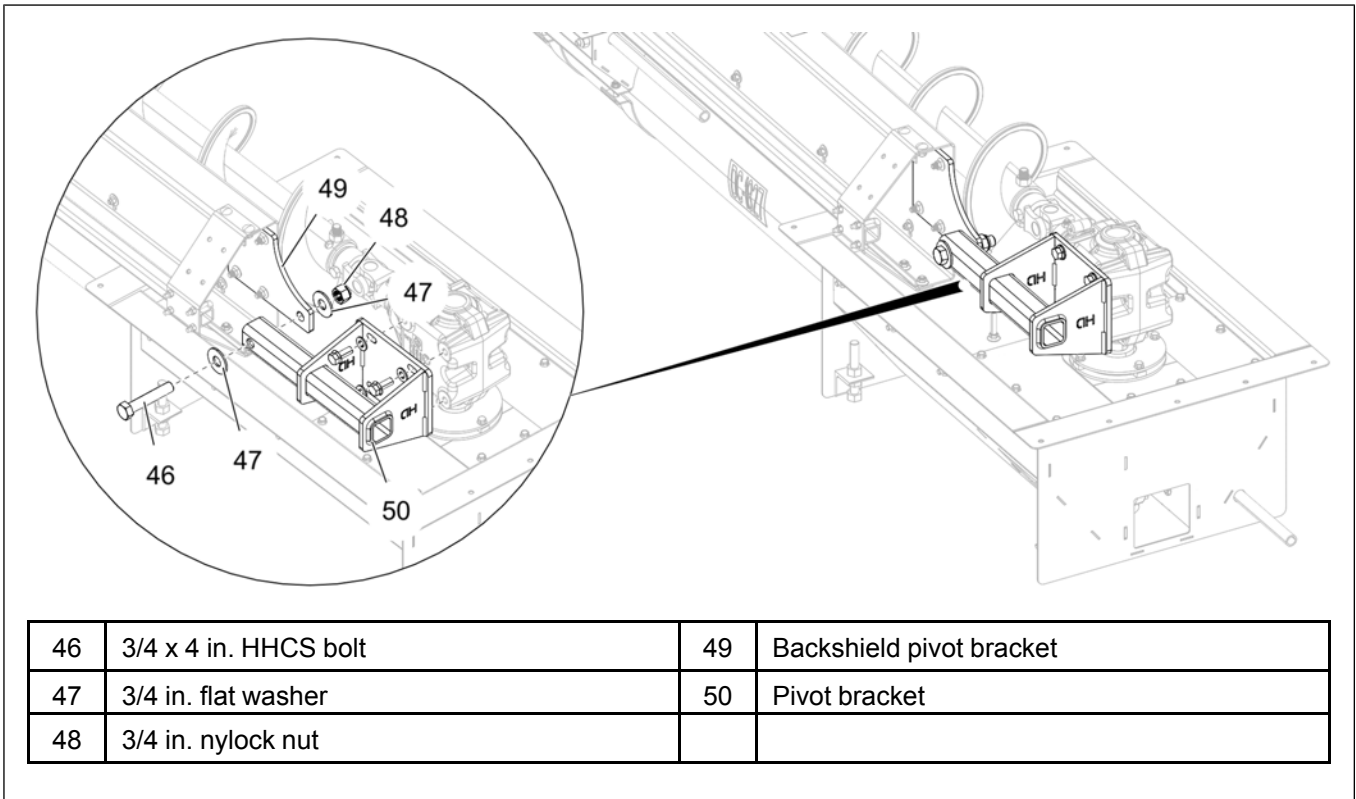

NOTE: Pick up at pivot bolt location *PRIOR* to tightening the four gearbox bolts and four backshield bolts. This will help raise the sweep arm for additional floor clearance.

Installing the Sweep Wheel

1. Attach the wheel (57) to the wheel mount (54) using eleven flange bolts (55) and eleven flat washers (56).

Figure 3-42 Attaching the wheel to wheel mount

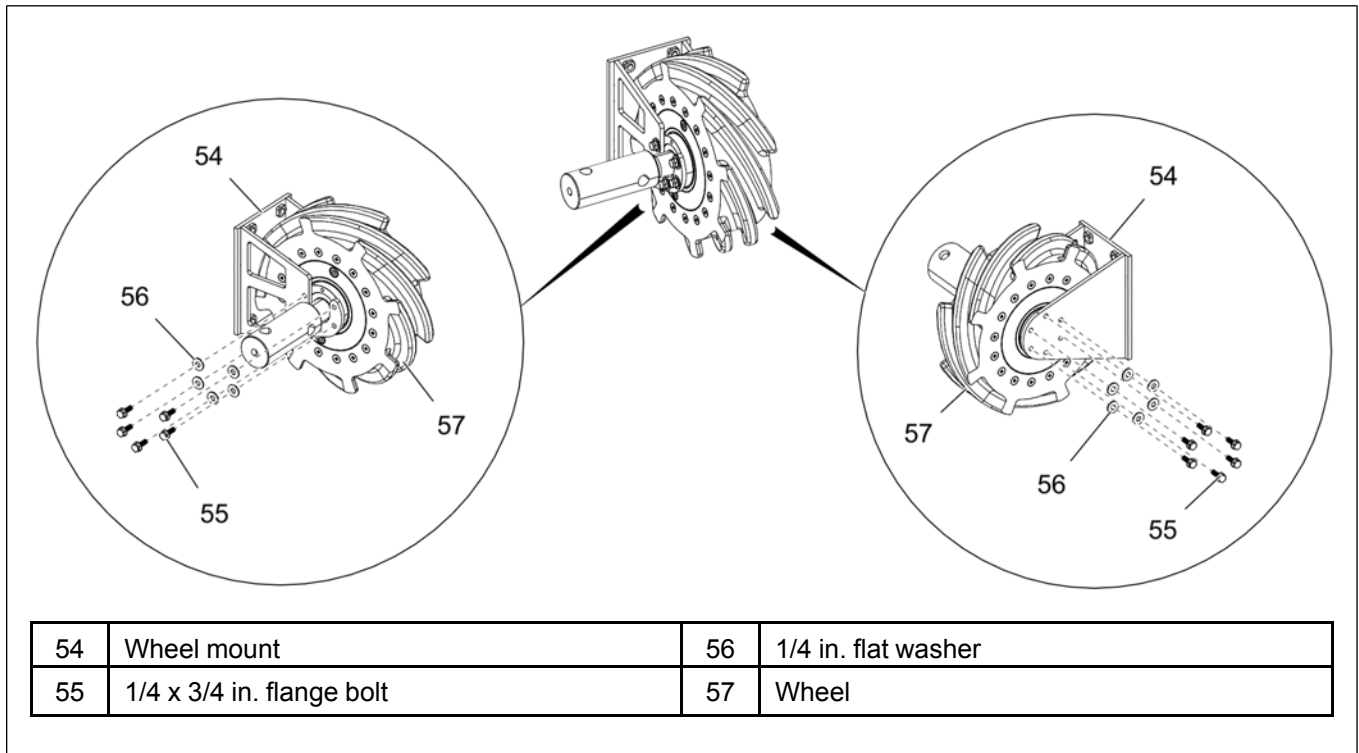

Chapter 3: Installation

- Slide wheel shaft (57) into the auger. Attach the wheel mount (54) to the shield (58) using four serrated flange bolts (4).

Figure 3-43 Attaching the wheel mount to shield

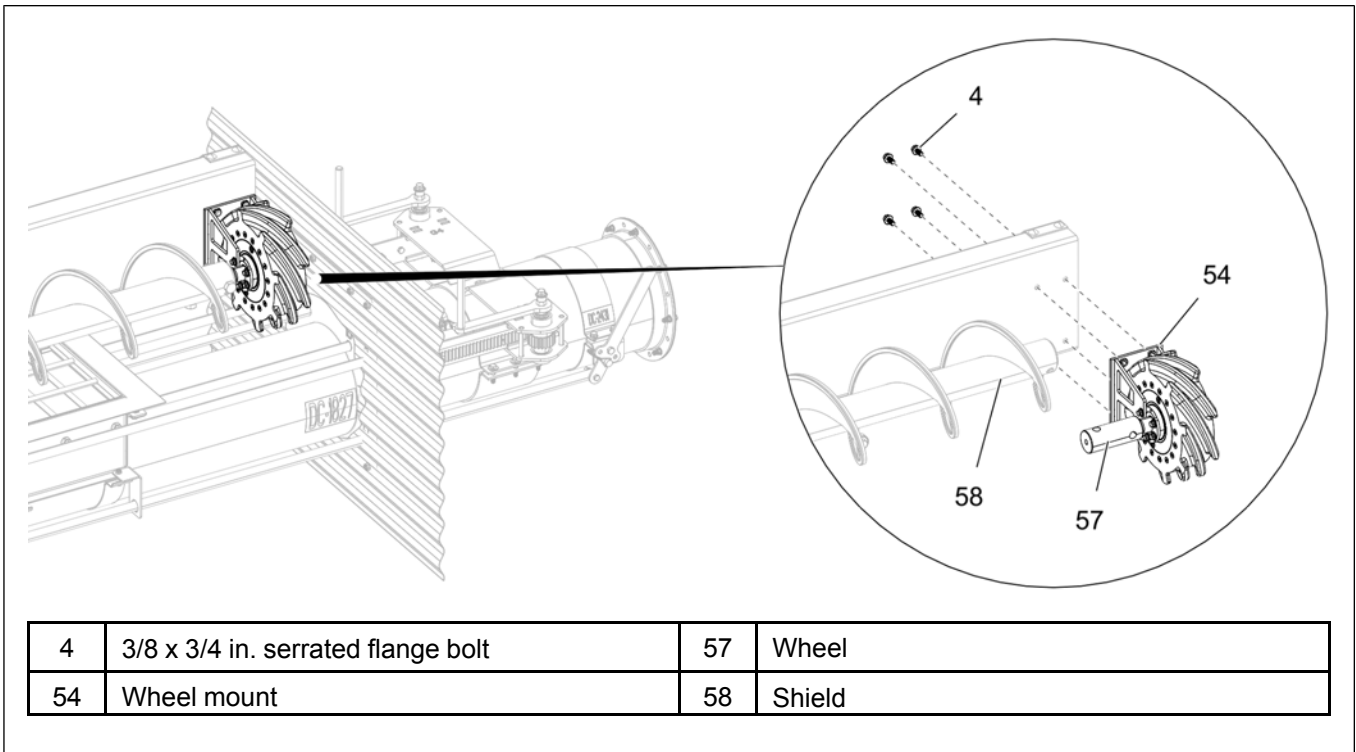

3. Attach the wheel (57) to the flight (59) with two HHCS bolts (93) and stover nuts (94).

Figure 3-44 Installing the wheel to auger

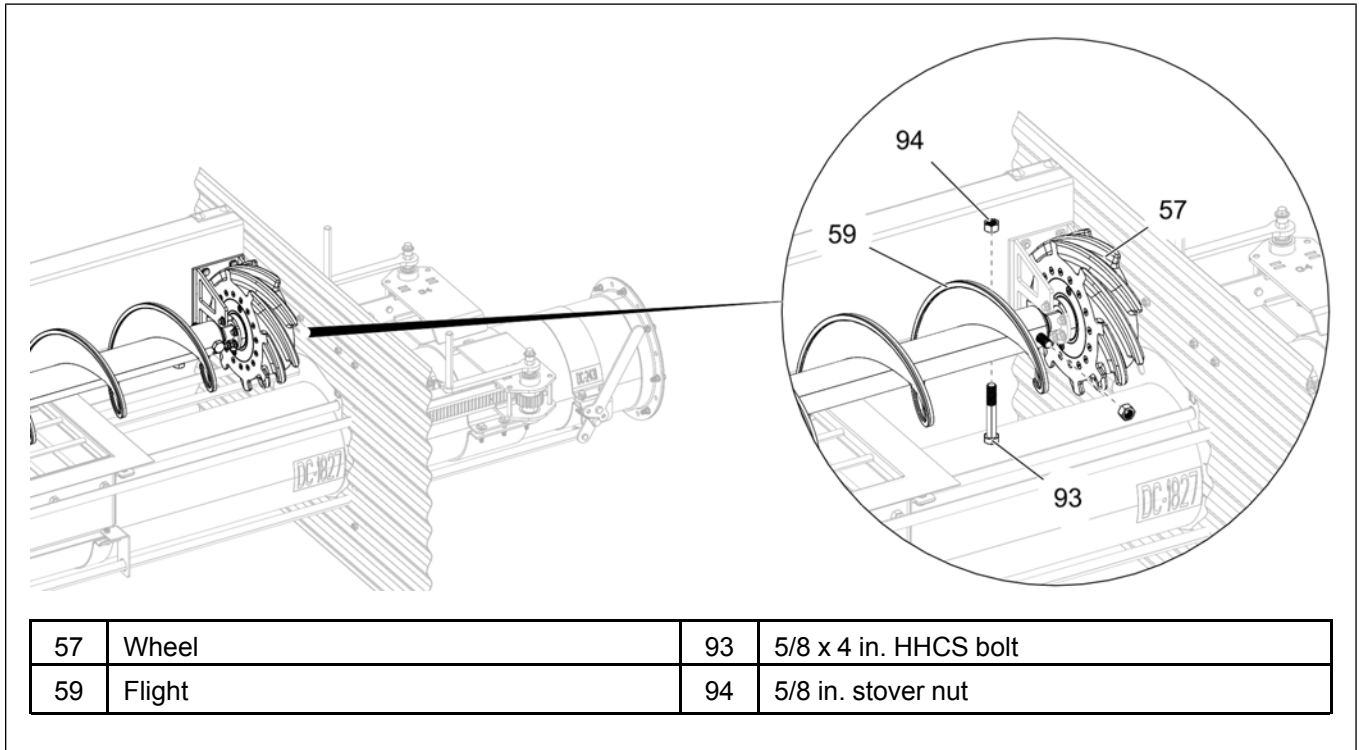

Adjusting the Wiper

What You Should Know

The sweep should be adjusted based on the highest point of the floor so that the sweep can run around the bin with proper clearance. Otherwise the sweep will not work as intended.

1. Loosen the flange bolts (27) in the backshield assembly to adjust the wiper (78) position.
2. Adjust the wiper (78) UP/DOWN depending on the highest point of the floor within the slots in the backshield assembly.
3. Tighten the wiper in position after adjustment using flange bolts (27), flat washers (14) and nylock nuts (66).

Figure 3-45 Wiper in UP position

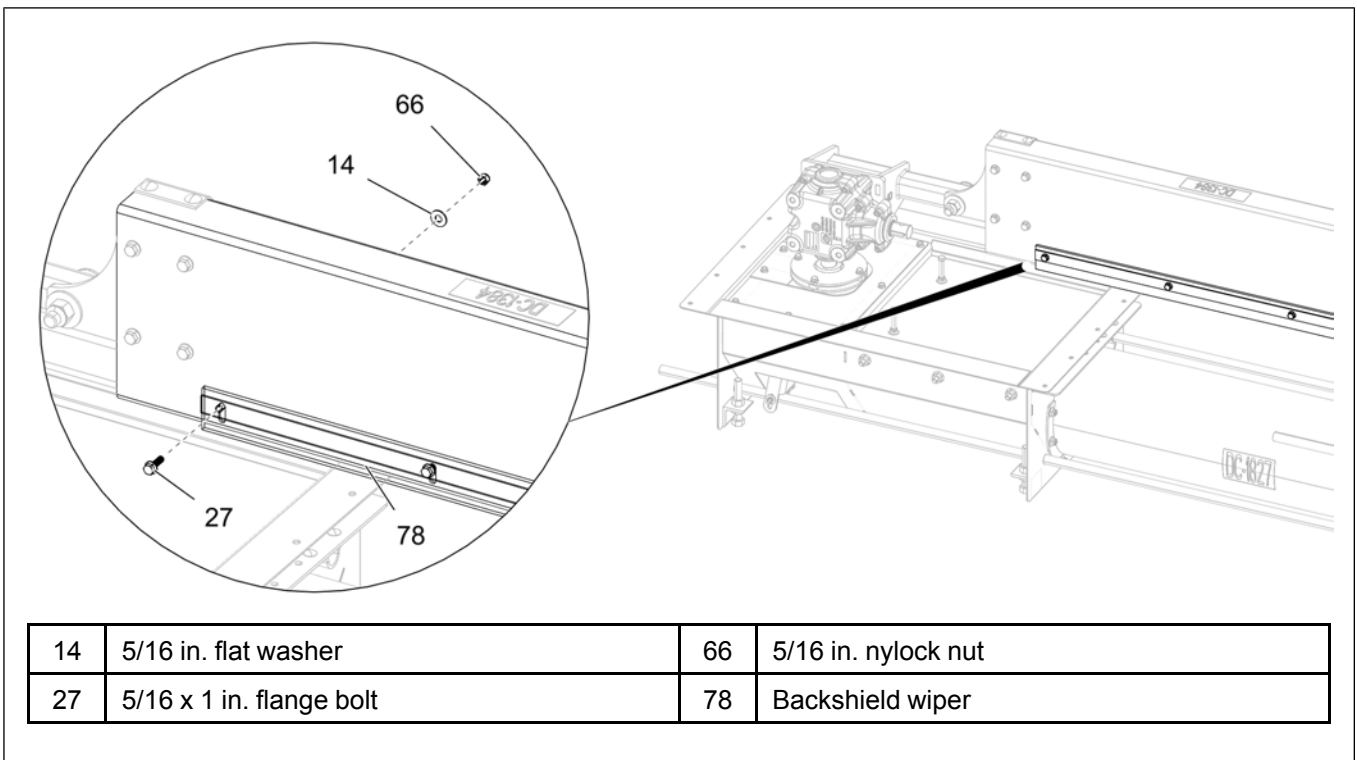
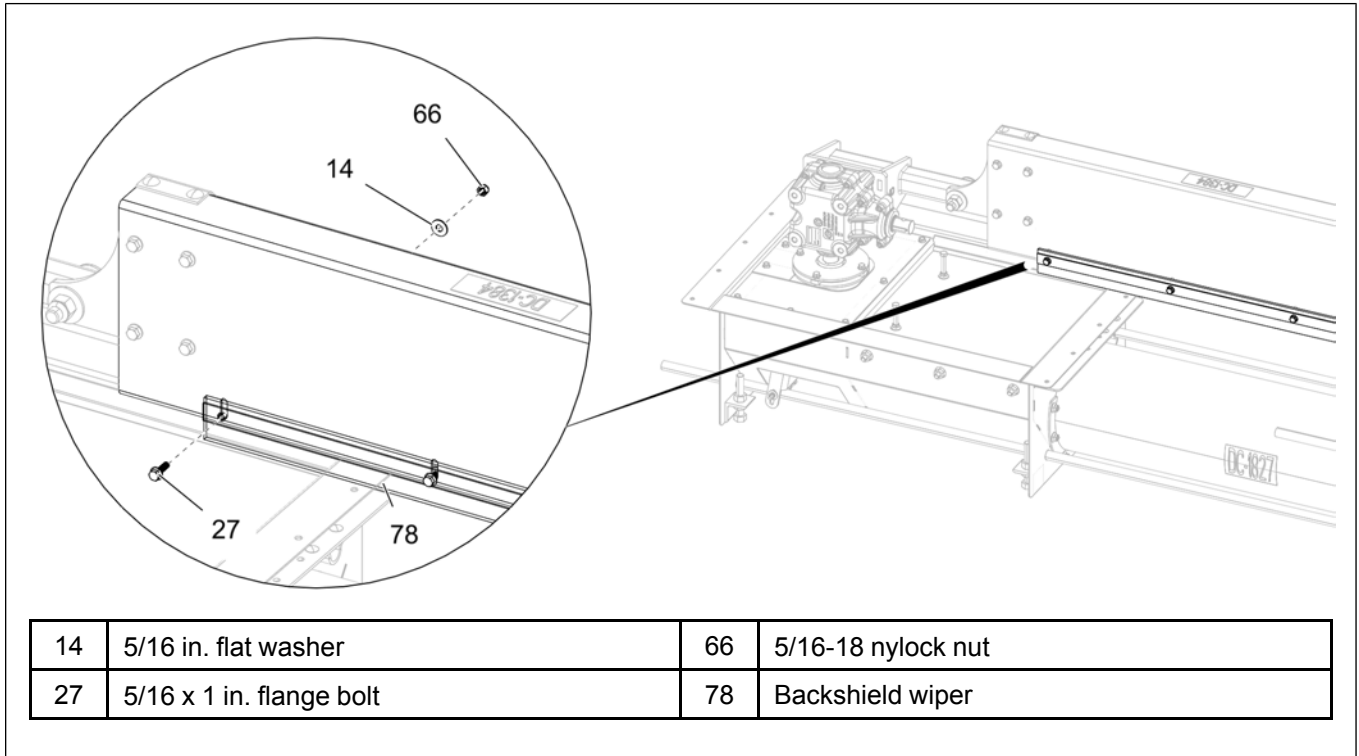

Figure 3-46 Wiper in DOWN position



Adjusting the Sweep Support Skid

Sweep support skid (83) is for 48 ft and larger sweeps.

If necessary, use the HHTB bolt (84) and nuts (100) in the hanger bracket assembly (82) to adjust the height of the auger off the floor for clearance.

Figure 3-47 Adjusting the sweep support skid

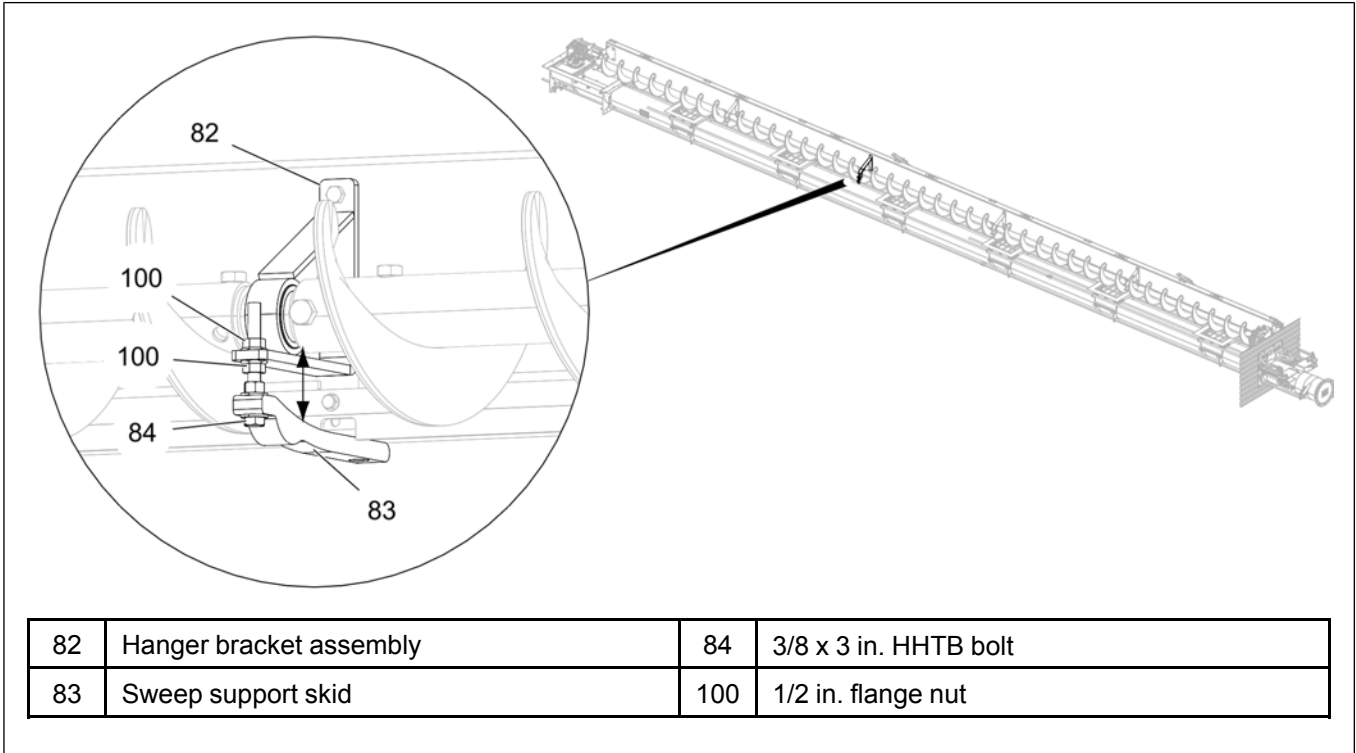

Installing the Backshield Support Assembly

Backshield support assembly is for 42 ft and 48 ft sweeps only.

1. Install the backshield support assembly (79) to the torque tube bracket (53) using mounting plate (80), HHCS bolts (81) and nylock nuts (66).

NOTE: *The backshield support assembly should be installed at the bracket location that does not allow it to interfere with any intermediate wells.*

Figure 3-48 *Installing the backshield support assembly*

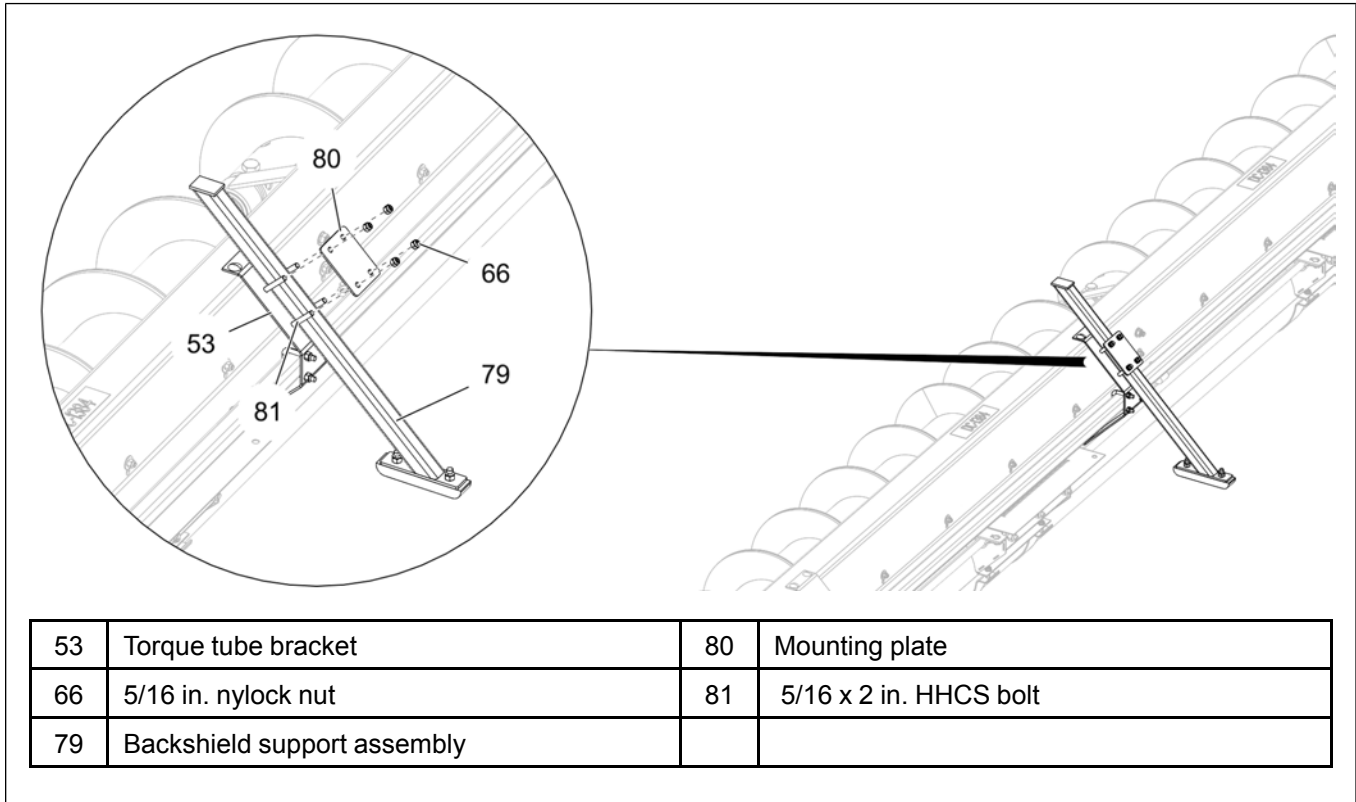

Chapter 3: Installation

- The backshield support assembly (79) can be adjusted in the direction (as shown) for proper sweep clearance.

NOTE: When sliding the support down closer to the floor, it will raise the sweep off the floor and put down pressure onto the reduction wheel.

Figure 3-49 Adjusting the backshield assembly

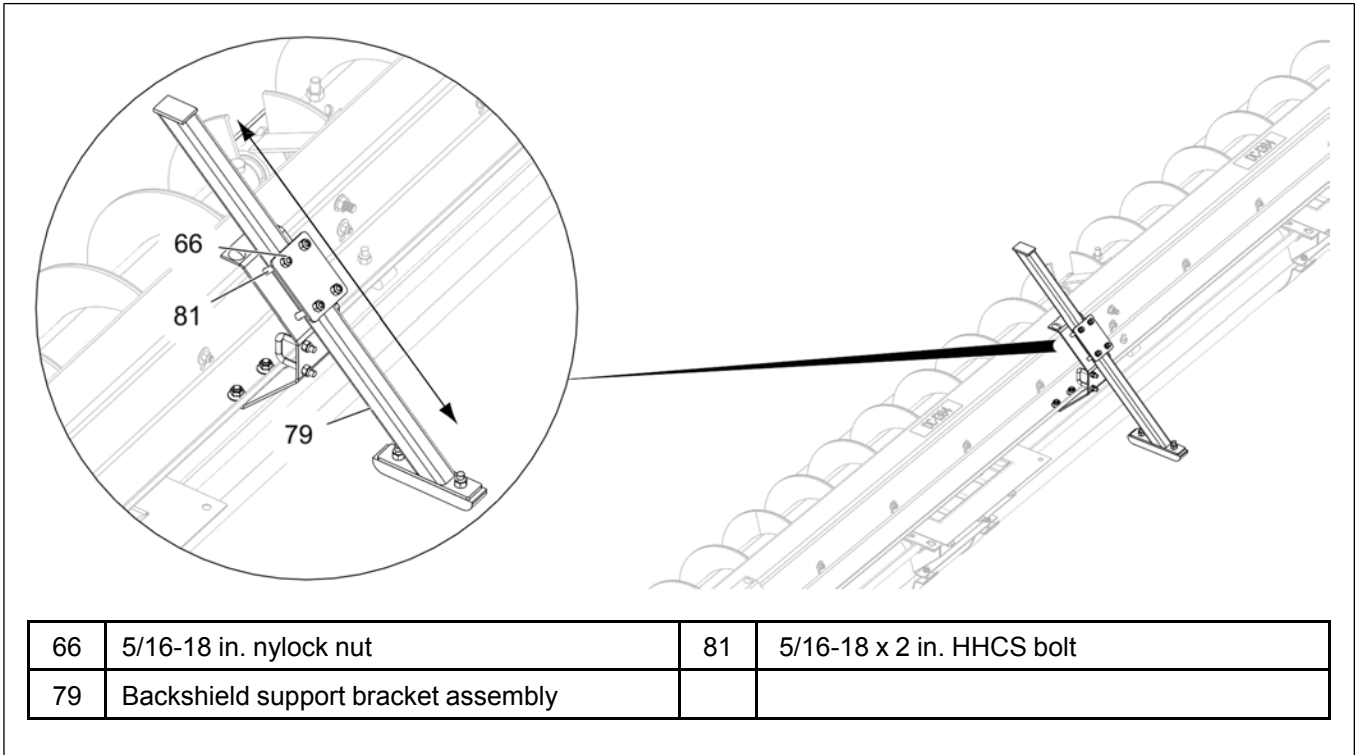

4 Operation

Topics Covered in this Chapter

- Power Recommendations
- Before Filling the Bin
- Performing Pre–Start Checks
- Operating the Auger
- Engaging the Clutch for Bin Sweep
- Final Clean Out

Power Recommendations

1. The horsepower recommendations are to auger reasonably dry grain. High moisture grain above (15%) will require greater power if maximum capacity is to be maintained. The maximum possible capacity will be less with high moisture grain than with dry grain. Use the electric motor of the correct size that operates at 1750 RPM. DO NOT use a motor size that is greater than what is shown for the largest bin size in the column.
2. Consideration should be given to the proper size auger for a batch drying or any intermittent type operations. When augers are stopped and restarted under full load, it may result in damage to the auger. Using a larger diameter auger and reducing its load level will be far better than subjecting a smaller diameter auger to big loads. If an auger is kept from absolute filling, it will make start-up easier and will convey more efficiently.

NOTE: *The auger capacity can fluctuate greatly under varying conditions. Moisture content, different commodities, amount of foreign matter and speeds all play a part in the performance of the auger. Twenty-five percent (25%) moisture may cut capacity by as much as forty percent (40%) under some conditions.*

Bin Dia (Ft.)	Horizontal Head	25° Head	Vertical Power Head
	Std HP	Std HP	Std HP
30	10	10	10
33	10	10	10
36	15	15	10
42	15	15	10
48	15	15	10
54	20	20	10
60	20	20	10
72	20	20	10



Electric motors and controls must be installed by a qualified electrician and must meet the standards set by the National Electrical Code and all local and state codes.

A main power disconnect switch capable of being locked only in the OFF position shall be provided. This shall be locked whenever work is being done on the auger.



A magnetic starter should be used to protect the motor when starting and stopping. It should stop the motor in case of power interruption, conductor fault, low voltage, circuit interruption or motor overload. Then the motor must be restarted manually.

Some motors have built-in thermal overload protection. If this type motor is used, use only those with a manual reset.

The motor starting controls must be located outside the bin. Locate the motor starting controls outside the bin but near the bin door so the operator has full view of the operation inside the bin.

Disconnect power before resetting motor overloads.

Reset and motor starting controls must be located so that the operator has full view of the entire operation.

Make certain electric motors are grounded.

Shut OFF power to adjust, service or clean.

Before Filling the Bin

1. Read the instructional decal located on the upper bin flange to learn how to control the direct gear drive power sweep well gates.
2. Close the center well and the intermediate well gates.
3. Position the sweep auger alongside of the intermediate wells.
4. Make sure the clutch is disengaged and locked out with pin.



1. DO NOT enter the grain bin unless all power driven equipment has been shut down and locked out. Never enter the grain bin unless monitored by another person.
2. DO NOT enter the bin if the grain has bridged or has flowed abnormally out of the bin as shown. Suffocation can occur if grain suddenly breaks loose, burying persons who are inside the bin.

Figure 4-1 *Abnormal grain flow*

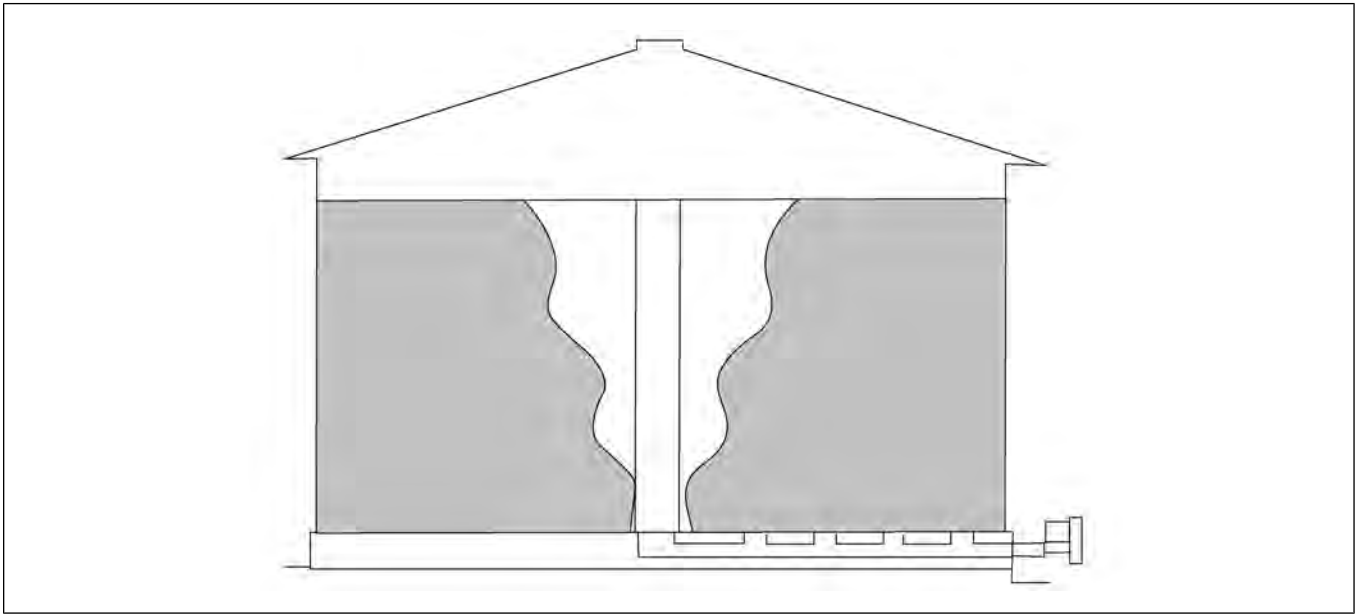

Abnormal grain flow can easily fall and bury a person, suffocating them. DO NOT enter a bin with abnormal grain flow.

Figure 4-2 *Bridged grain flow*

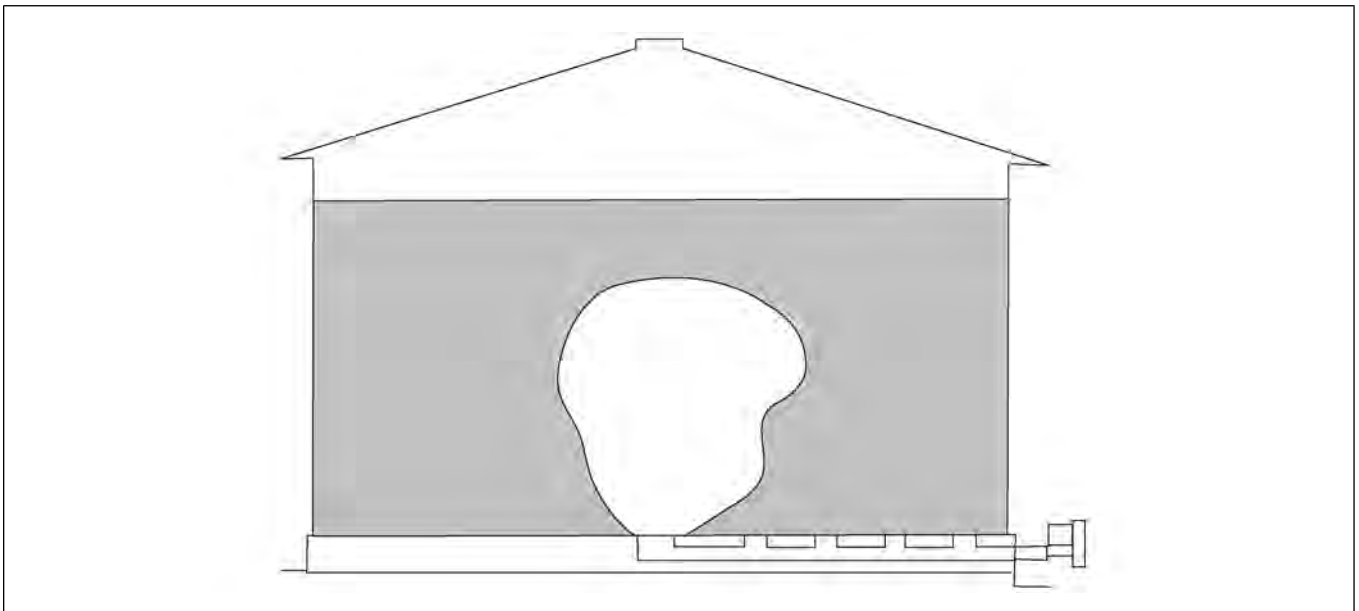

Bridged grain can easily break loose and bury a person, suffocating them. DO NOT enter a bin with bridged grain.

Performing Pre-Start Checks



*Failure to perform any or all of these pre-start checks may cause damage to the equipment and/or cause **SERIOUS INJURY** or **DEATH** to those in the work area. Failure to perform any or all of these pre-start checks may also be a misuse of the equipment. Any misuse of the equipment may void the warranty.*

1. Make sure ALL belts are tensioned properly.
2. Make sure ALL shields are in place and that the belt(s) and pulley(s) are able to move freely.



***ALWAYS** keep ALL guards and shields in place, until all the power is disconnected and locked out.*

3. Inspect the drive unit for any problems or potential problems.
4. Be aware of any emergency shut down procedures. Two people must always be in a position where the operation of the equipment can be monitored.
5. Before starting the auger for the first time, make sure that all parts are assembled correctly according to the instructions in this manual.



*Make certain **ONLY** trained operators are in the work area before operating or moving the machine. Two (2) people must always be in a position where the operation of the equipment can be monitored.*

Operating the Auger



DO NOT start/stop the auger while it is under load, this may cause the auger to “jam”.



Failures may occur if the auger is run full before it has been “polished” during the “break-in” period.



Be aware of any unusual vibration or noises during the initial start-up and “break-in” period. If anything unusual is detected, immediately shut down the auger and disconnect and lock out the power supply before servicing. Visually inspect the auger periodically during operation.

1. Start the unloading auger. The motor is located on the power head outside the bin on the unload tube. To figure out the horsepower needed for the equipment, use the horsepower chart.
2. Make sure the lock pin is inserted through the rack and pinion tube (18) and center well control rod (11). Make sure the intermediate well control rod is not attached to the rack and pinion tube (18).

Figure 4-3 Opening the center well gate

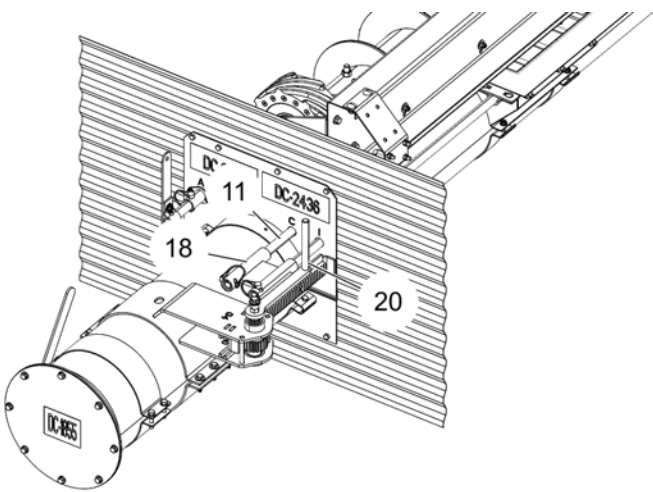

11	Center well control rod	20	Rack and pinion handle
18	Rack and pinion tube		

3. Using the handle (20) on rack and pinion, open center gate (indicated with “C”) until desired flow is established. It should not be necessary to open gate more than 3 in. to 6 in. Do not open the gate more than 3 in. to 6 in. as the flow of grain into the center well will be at a higher rate than what the unload system can remove. This will cause the auger to plug or jam.
4. Always close the well gates and allow the unloader to clean out before stopping the unloader.

Chapter 4: Operation

- When grain flow stops from the center well, close the center well gate and remove the pin. Insert the pin through the intermediate well control rod (17) (indicated with "I"). Remaining grain should look like as shown below.

Figure 4-4 Intermediate well control rod

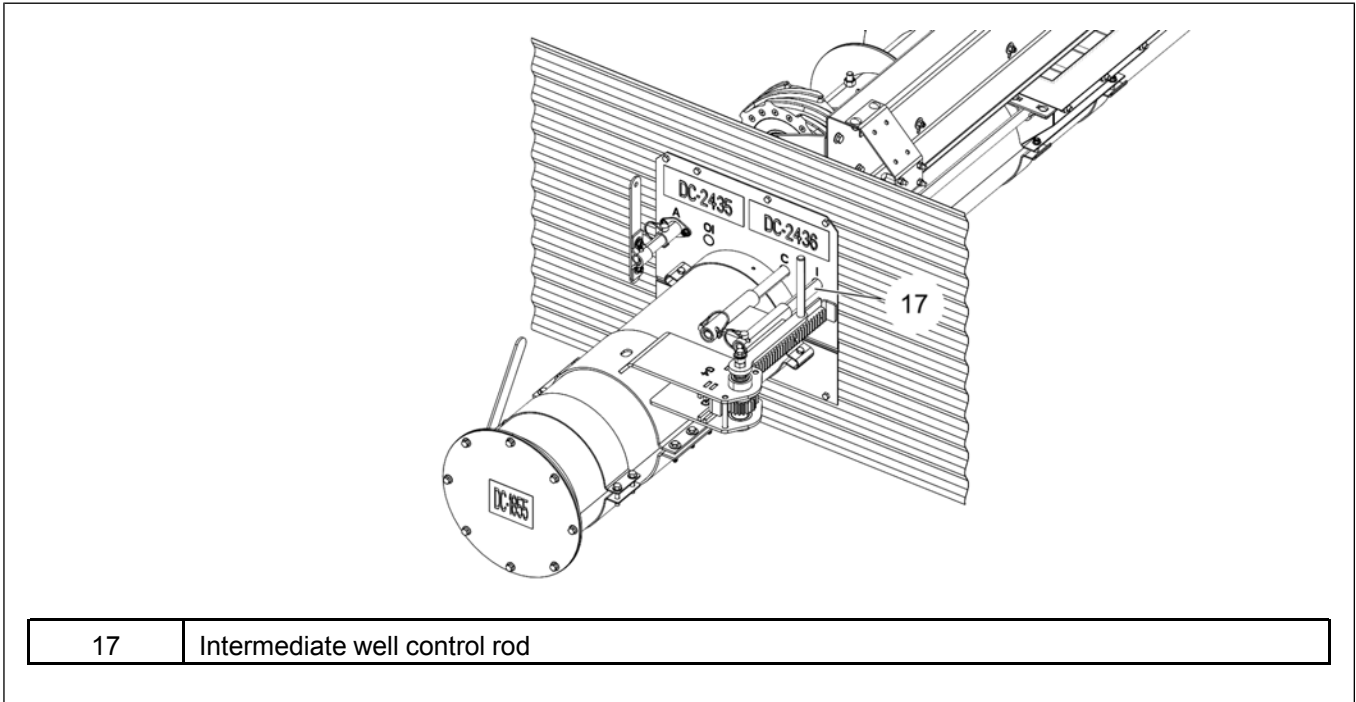
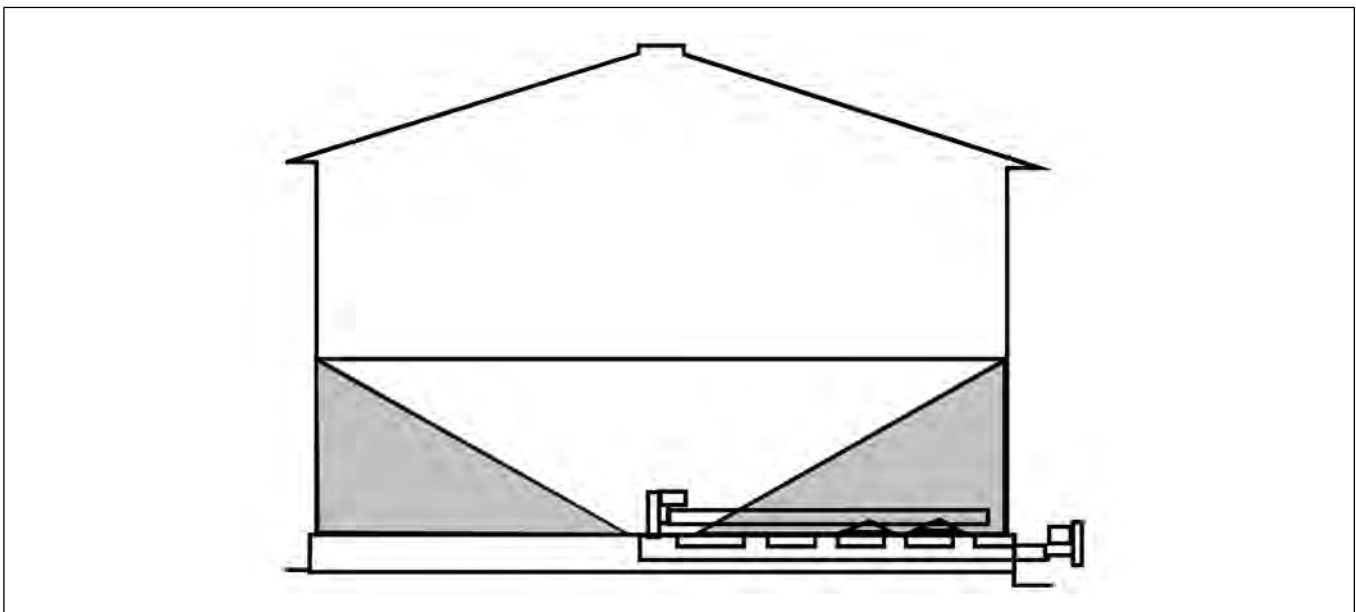

Figure 4-5 Grain flow from the center well gate



6. Gradually open the gates until the desired flow of grain is reached. You should not open the gate more than 2 in. to 4 in. The remaining grain should look like as shown below.

NOTE: *If auxiliary well is installed, open it before opening intermediate gates.*

Figure 4-6 Grain flow from the intermediate gates

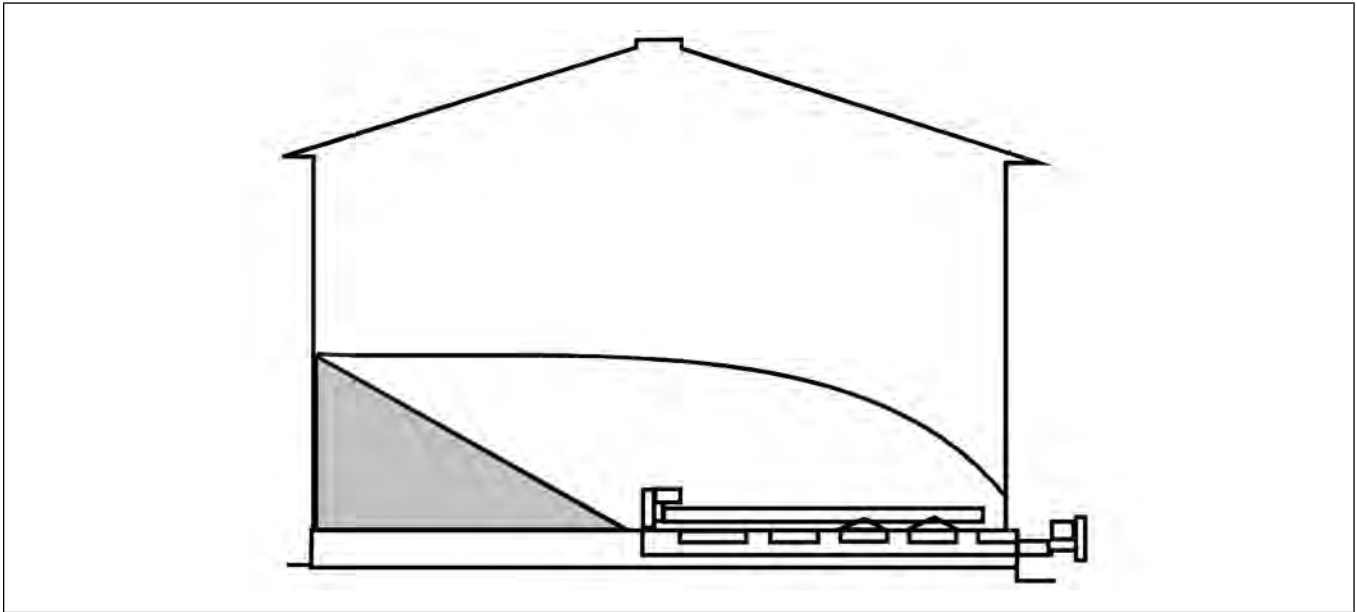

Engaging the Clutch for Bin Sweep

1. All power should be OFF and locked out before starting.
2. Close the intermediate wells.
3. Remove the pin (16) from the clutch handle (30).
4. Pull the clutch handle (30) away from the bin to engage the gearbox clutch.

Figure 4-7 Engaging the clutch

16	Lock pin	29	Clutch handle pivot
21	Clutch control rod	30	Clutch handle

Letter	How to operate	Sweep operating instructions
A: Auxiliary well control	Pull to open (if equipped)	<p>IMPORTANT: Before filling bin, close center well and intermediate well gates</p> <p>Instructions:</p> <ol style="list-style-type: none"> a. Be sure power sweep clutch control is DIS-ENGAGED and ensure locking pin is inserted. b. Start unloading auger. Open center well gate. c. When grain stops flowing from center well gate, close center well gate and open intermediate wells. d. When grain stops flowing from intermediate wells, stop auger and close intermediate wells. Engage power sweep and open center well gate. Start auger.
C: Center well control	To open, rotate handle so rod pulls out of bin	
I: Intermediate well control	To open, rotate handle so rod pulls out of bin	
CL: Power sweep clutch control	Pull handle to engage power sweep	
OI: Outer intermediate well control	To open, rotate handle so rod pulls out of bin (available only for 10 in. HD sweeps for 42 ft – 72 ft. bins)	

- Assemble the pin (16) through the clutch handle (30) and pivot bracket (29). If they do not align, start the motor and pull the handle until the holes align and insert pin (16).

Figure 4-8 Locking the clutch handle

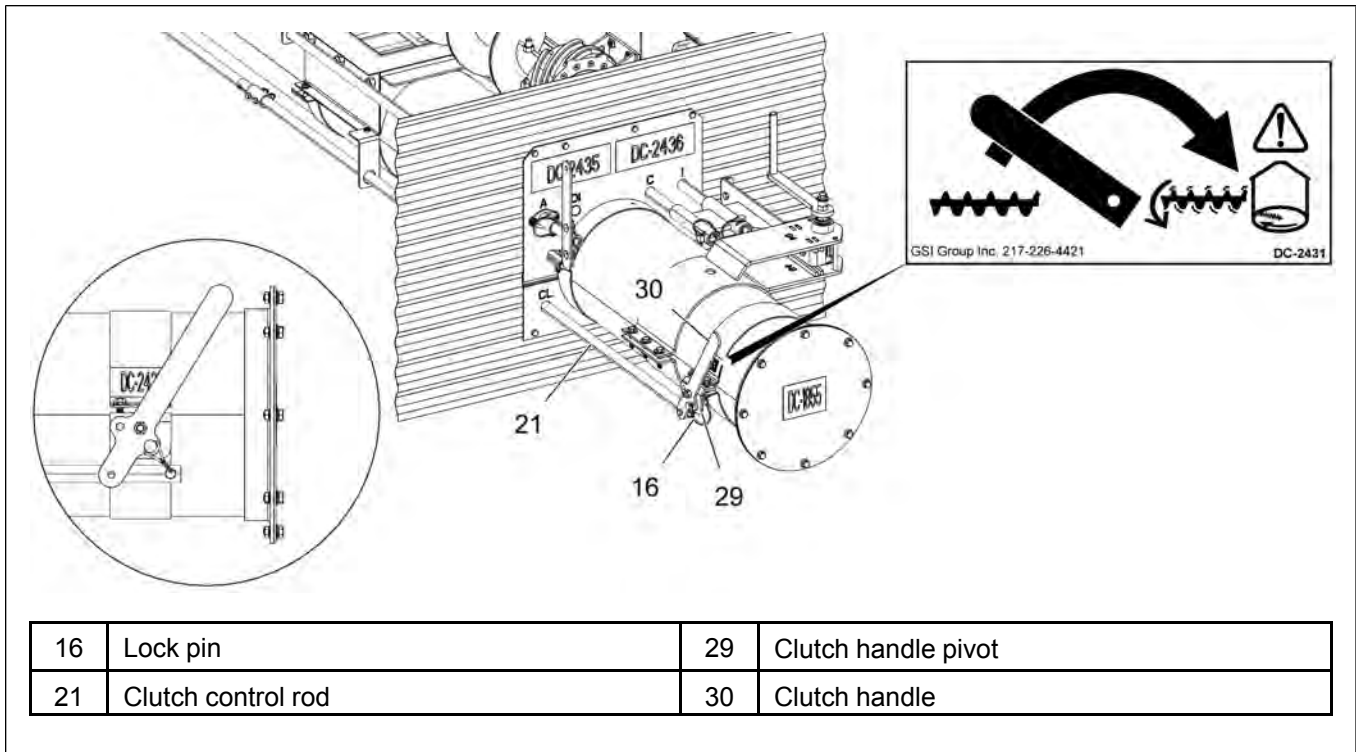

The center well gate must be FULLY open during the bin sweep operation.

- Restore power and start the power sweep motor. The sweep auger will start along with the unload auger. The sweep auger will remain on the floor and clear most of the grain in one pass. A second pass will clean out additional grain, before final clean out.

Final Clean Out

The following procedure is recommended for cleaning the floor of the bin after the sweep auger has removed as much grain as possible.



Keep out of bin while sweep is in operation. Rapidly traveling sweep auger. The sweep auger will move rapidly around the bin when the bin is nearly empty.



Stay clear of the under floor unloader at the bin wells. The under floor unloader is exposed at these locations in the bin floor.



ALWAYS keep ALL guards and shields in place, until all the power is disconnected and locked out.

1. Clean (scoop and sweep by hand) the outer area of the floor into a circular pile towards the center of the bin.
2. Get out of the bin.
3. After making sure everyone is outside the bin and clear of the equipment, start the under floor unloader and the sweep auger. In a short time, the circular pile towards the center of the bin will have been removed.



Stay clear of the under floor unloader at the bin wells. The under floor unloader is exposed at these locations in the bin floor.

4. Scoop and sweep by hand the remaining floor area to the center of the bin.
5. Get out of the bin.
6. Repeat the above steps (step-3 to step-6) until all grain has been removed from the bin.

Figure 4-9 *Cleaning the floor*

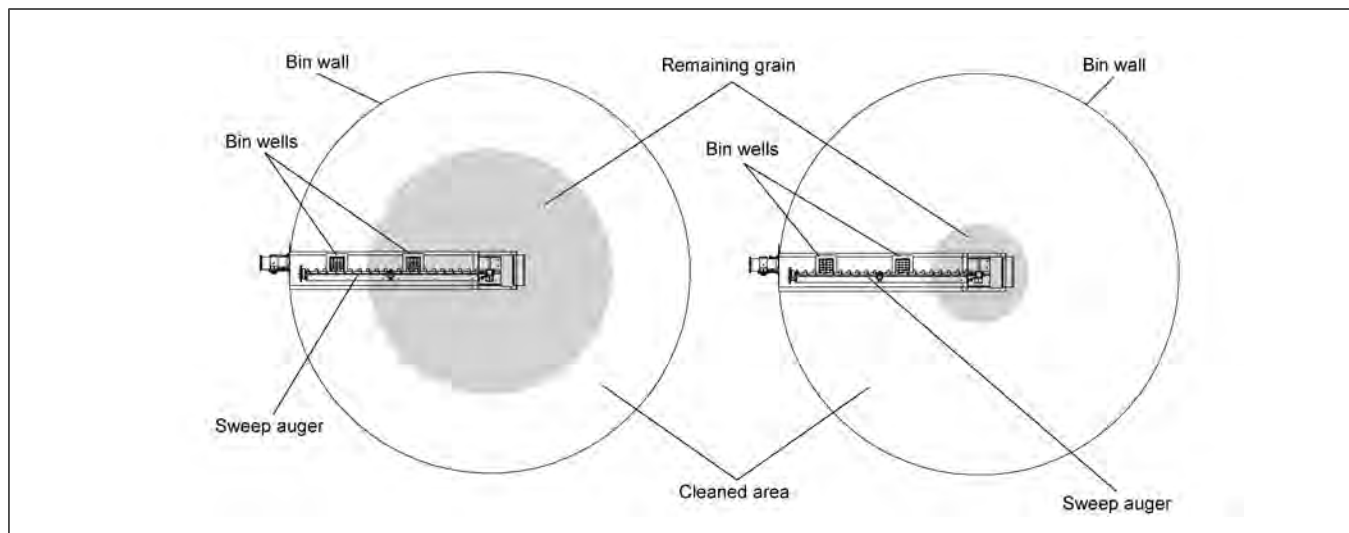

5 Shut Down

Topics Covered in this Chapter

- Normal Shut Down
- Emergency Shut Down
- Storage Preparation

Normal Shut Down

1. Before shutting down the unit, be sure the augers are empty.
2. Disconnect and lock out the power source before leaving the work area.

Emergency Shut Down

1. Know how to shut down the auger in case of an emergency.
2. Do not restart the auger while it is under load.



NEVER start the equipment under load. Doing so may cause damage. This type of damage is considered a misuse of the equipment. Any misuse of the equipment may void the warranty.

3. Close the bin well control gates.
4. Reconnect and unlock the power source.
5. Clear the auger gradually, until there is no grain and there are no obstructions.

Storage Preparation

1. Read the instructional decal located on the upper bin flange to learn how to control the direct gear drive power sweep well gates.
2. Close the center well and the intermediate well gates.
3. Position the sweep auger alongside of the intermediate wells.
4. Make sure the clutch is disengaged and locked out with pin.
5. Be sure the unload tube is empty.
6. Shut down the auger.
7. Make sure all fasteners are tight.



DO NOT enter the grain bin unless all power driven equipment has been shut down.

NOTES

6 Maintenance and Troubleshooting

Topics Covered in this Chapter

- Maintaining the Auger
- Troubleshooting

Maintaining the Auger

IMPORTANT: *For locations that will be operating, the sweep in temperatures colder than -5° Fahrenheit, the grease in both gearboxes should be removed and replaced with 80W90 gear oil (40 fluid oz. each).*



Properly maintaining this equipment will help to ensure it continues to work properly. Failure to properly maintain this equipment may result in damage to the equipment or may cause *SERIOUS INJURY* or *DEATH* to the operator.

Failure to properly maintain this equipment may also be a misuse of the equipment. Any misuse of the equipment may void the warranty.

1. The U-joint must be lubricated with SAE multipurpose grease every 10 operational hours or after each use.
2. The upper and lower gearboxes are grease filled and do not need operational maintenance. If repairing the gearboxes, it is recommended to fill them each with 40 fluid oz. of Mobilux EP 023 grease. If this grease is not used, 40 fluid oz. of SAE 80W90 gear oil is suggested.
3. Use caution when repairing or replacing equipment parts.
4. Make sure ALL decals are legible and tightly attached to the auger. If necessary, replace them **FREE OF CHARGE** by contacting the dealer, warehouse or the manufacturer.
5. Mount controls for any electric motors at a safe distance from the machine and in a location accessible in case of an emergency.
6. Make sure ALL electrical wiring is not damaged and that it meets proper wiring codes.
7. Make sure ALL components are in good working condition before use.

Troubleshooting

Problem	Possible Cause	Solution
The auger is vibrating.	The drive belt may be too tight, binding the head stub and flight. Damage can occur to the auger flighting, causing noise. Damage usually is caused from foreign material being run through the auger.	Adjust the drive belt to the proper tightness.
		It may be necessary to remove the flighting for inspection.
Capacity is too low.	There may not be enough grain reaching the auger.	Make sure the intake has not bridged over, restricting flow. The flighting at the intake should be covered with grain for maximum capacity.
	The auger is moving too slowly.	Check the auger speed. Low capacity will result from speeds slower than recommended.
The auger plugs.	The auger may be "jamming" because too much grain is reaching the auger.	Decrease the amount of grain the auger is gathering.
	The motor may be too small or wired improperly.	If the motor is a newer light weight aluminum type, the next larger size may be desirable.
	The grain may be wet.	If wet grain or other hard-to-move material is being augered, use a larger size motor than recommended for normal use.
	The auger may be jammed with foreign material.	Remove any foreign material in the auger.
	The discharge end may be plugged.	Unplug any plugs at the discharge end of the auger.
The sweep flight and shield are no longer moving.	Too much drag.	Check the clearance between the shield and the bin floor. Make sure there is room for the auger to move. Adjusting the shield may be necessary.
	Worn sweep wheel.	The sweep wheel wears down over time. Replace the wheel.
	Unconditioned grain.	Moisture and/or insects can cause the grain to harden or "Cake-up". Disconnect and lock out the power to the auger before going into the bin to correct this problem or to address any other problem.
	Clutch disengaged.	Pull the clutch hand to engage and use pin to lock it in place.

7 Parts List

Topics Covered in this Chapter

- Center Well
- Intermediate Well (30 Ft — 36 Ft Bins)
- Outside Intermediate Well (For 42 Ft and Larger Bins)
- Auxiliary Kits (Optional)
- Single Rack and Pinion (30 Ft — 36 Ft)
- Double Rack and Pinion (42 Ft — 72 Ft)
- Bin Flange
- Sweep Wheel
- Unload Tube Flight
- Clutch Control
- Backshield with Two Augers for Standard Sweeps (30 Ft Bins)
- Backshield with Two Augers for Short Sweeps (30 Ft Bins)
- Backshield with Three Augers for Standard Sweeps (33 Ft – 42 Ft Bins)
- Backshield with Three Augers for Short Sweeps (33 Ft – 42 Ft Bins)
- Backshield with Four Augers for Standard Sweeps (48 Ft and 54 Ft Bins)
- Backshield with Four Augers Short Sweeps (48 Ft and 54 Ft Bins)
- Backshield with Five Augers for Standard Sweeps (60 Ft and 66 Ft Bins)
- Backshield with Five Augers for Short Sweeps (60 Ft and 66 Ft Bins)
- Backshield with Six Augers for Standard Sweeps (72 Ft Bins)
- Backshield with Six Augers for Short Sweeps (72 Ft Bins)
- Backshield Connections

Center Well

Figure 7-1 Center well – Exploded view

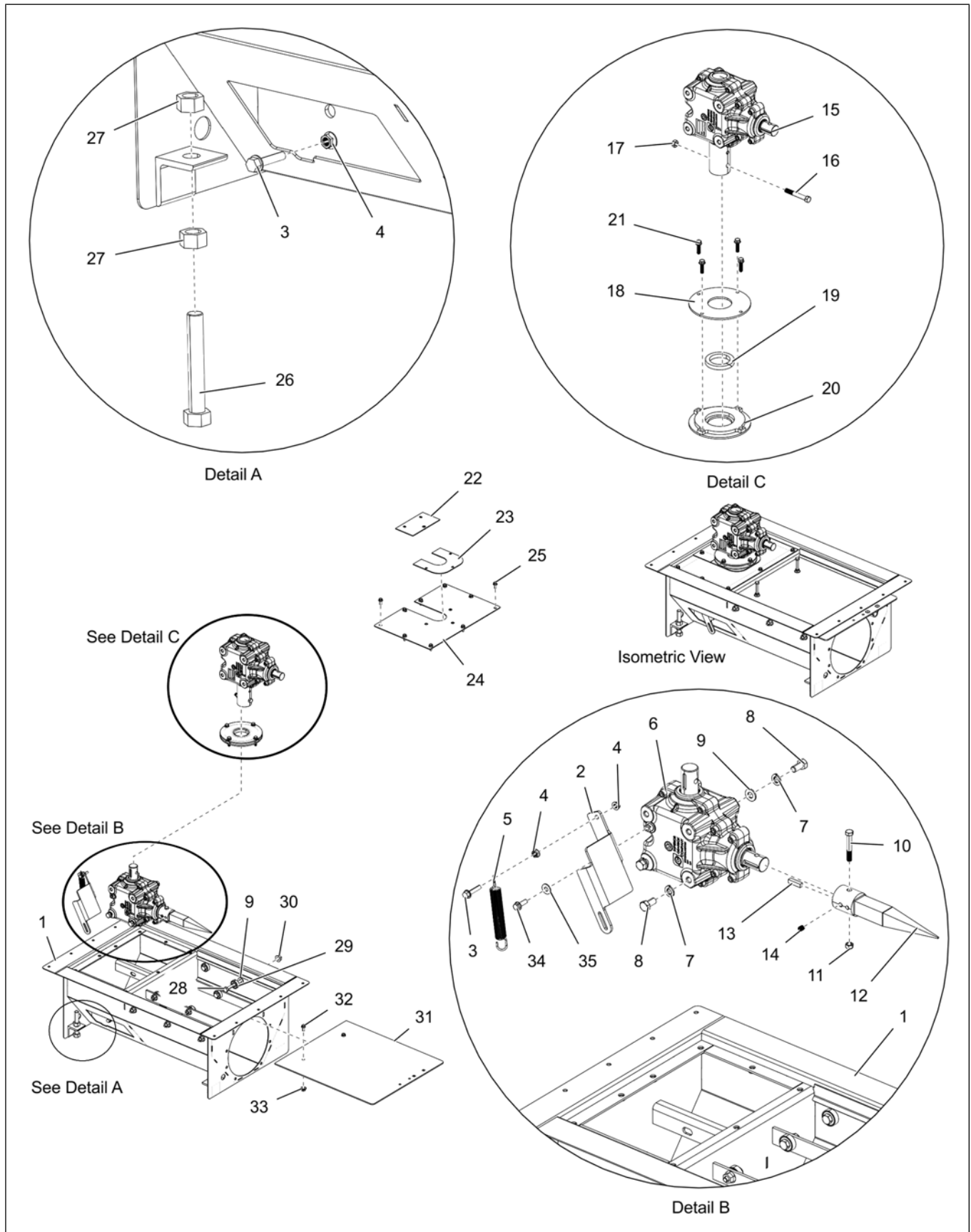

Table 7-1 Center well – Parts list

Ref #	Part #	Description
1	GC20575-Y	Center well weldment 10 in. ochre
2	GK80541	Center well linkage plate
3	S-10185	5/16 x 1-1/2 in. flange bolt
4	S-3611	5/16 in. flange nut
5	GK80655	Spring, extension 6.5L x .75D x .120 wire galv. HDMB
6	GK80597	Gearbox, DGD lower shifting 1.25:1 ratio
7	S-236	1/2 in. split lock washer
8	S-7935	1/2 x 1 in. HHCS bolt
9	S-2120	1/2 in. flat washer
10	S-10107	3/8 x 2-1/2 in. HHCS bolt
11	S-8251	3/8 in. stover nut
12	GK80540	Center well square shaft
13	S-10335	5/16 x 1-1/4 in. square key
14	S-7256	3/8 x 3/8 in. set screw
15	GK80600	Gearbox, DGD upper 1.35:1 ratio, external shaft w/ coupler
16	S-8316	7/16 x 3 in. HHCS bolt
17	S-8317	7/16 in. stover nut
18	GC20413-Y	Seal retainer flange
19	GK80364	Coupler seal
20	GK80363-Y	Seal retainer weldment
21	S-8135	5/16 x 1-1/4 in. flange bolt
22	GK80366	Center well back cover weldment
23	GK80542	Center well front cover
24	GK80365	Center well front cover weldment
25	S-6606	5/16 x 3/4 in. flange bolt
26	S-9154	5/8 x 4 in. HHTB bolt
27	S-4110	5/8 in. hex nut
28	S-8760	1/2 x 1-1/2 in. HHTB bolt
29	MHC01055	Bearing, radial 1.375 OD, 0.50 ID double-shielded
30	S-8506	1/2 in. flange nut
31	GK80361	Center well gate
32	S-9067	3/8 x 3/4 in. flange bolt
33	S-968	3/8 in. flange nut
34	S-7470	5/16 x 1 in. flange bolt
35	S-845	5/16 in. flat washer

Intermediate Well (30 Ft — 36 Ft Bins)

Figure 7-2 Intermediate well – Exploded view

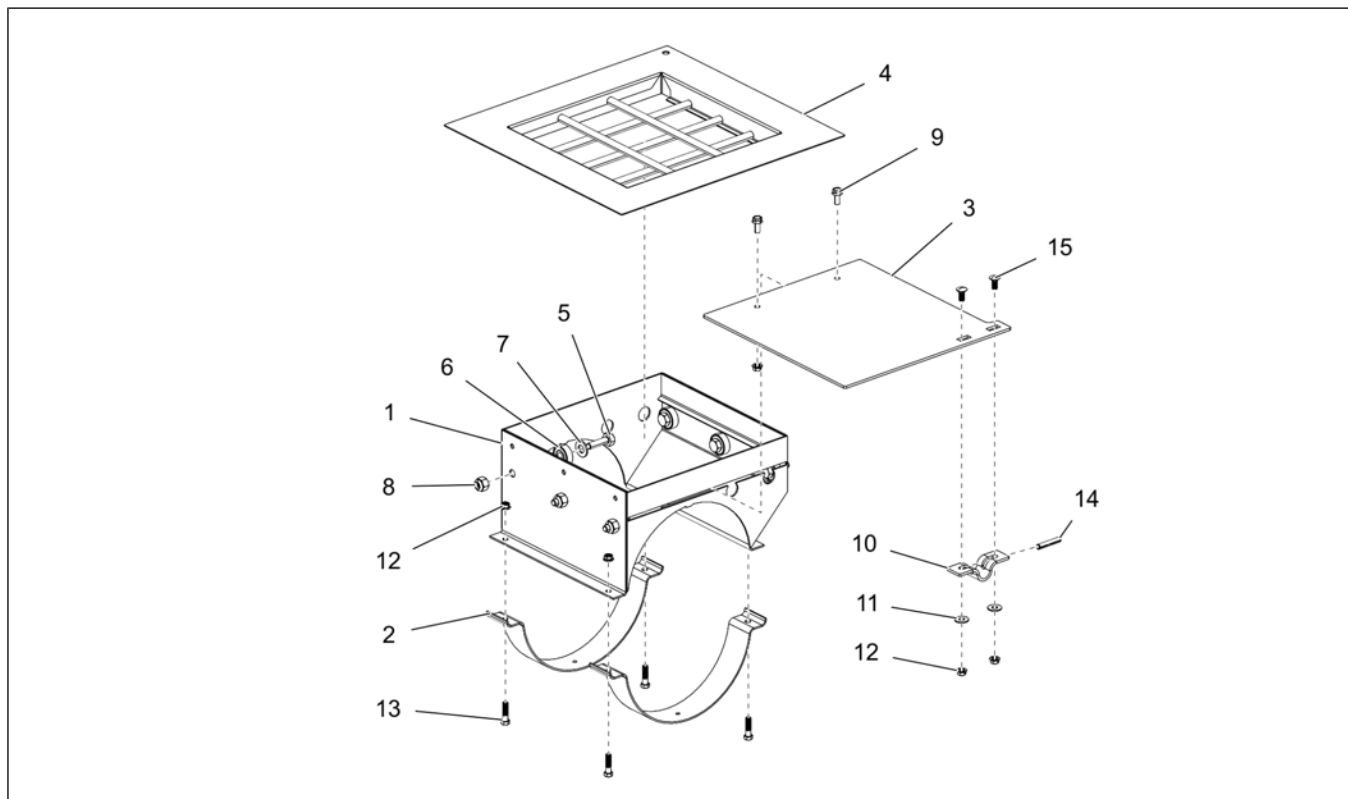

Table 7-2 Intermediate well - Parts list

Ref #	Part #	Description
1	GK80554-Y	Intermediate well weldment – 10 in. ochre
2	GK1057	Half band, 10 in. x 2 in. 12 ga. galv.
3	GK80556	Intermediate well gate
4	GK80561-Y	Intermediate well top flange – 10 in. ochre
5	S-8760	1/2 x 1-1/2 in. HHTB bolt
6	MHC01055	Bearing, radial 1.375 OD, 0.50 ID double-shielded
7	S-2120	1/2 in. flat washer
8	S-8260	1/2 in. nylock nut
9	S-6606	5/16 x 3/4 in. flange bolt
10	GK1726	Control gate clamp for SCH 40 x 1/2 in.
11	S-1937	5/16 in. flat washer SAE
12	S-3611	5/16 in. flange nut
13	S-9350	5/16 x 1-1/4 in. HHCS bolt
14	S-8397	5/16 x 1-3/4 in. spring pin
15	S-6076	5/16 x 3/4 in. carriage bolt

Outside Intermediate Well (For 42 Ft and Larger Bins)

Figure 7-3 Outside intermediate well – Exploded view

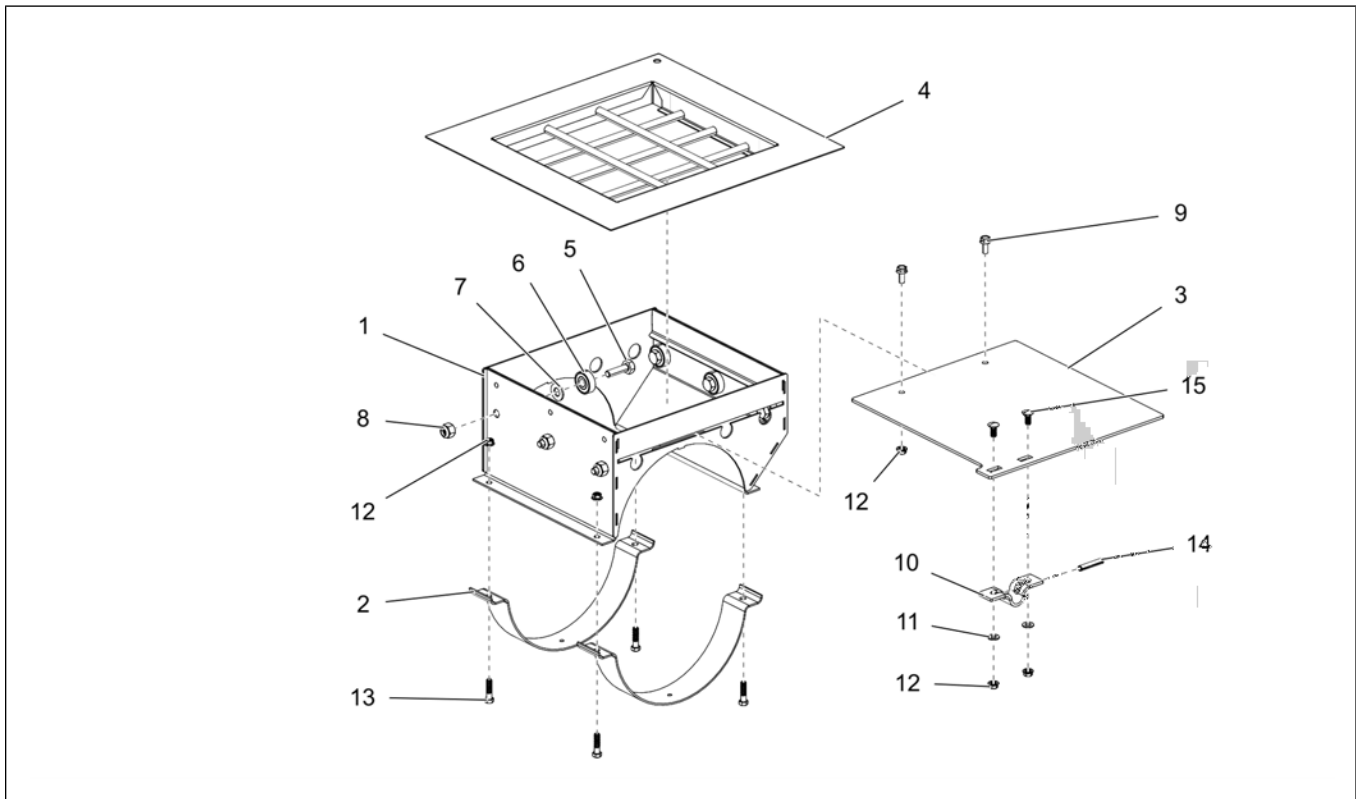

Table 7-3 Outside intermediate well – Parts list

Ref #	Part #	Description
1	GK80557-Y	Outside intermediate well weldment – 10 in. ochre
2	GK1057	Half band, 10 in. x 2 in. 12 ga. galv.
3	GK80556	Intermediate well gate
4	GK80561-Y	Intermediate well top flange – 10 in. ochre
5	S-8760	1/2 x 1-1/2 in. HHTB bolt
6	MHC01055	Bearing, radial 1.375 OD, 0.50 ID double-shielded
7	S-2120	1/2 in. flat washer
8	S-8260	1/2 in. nylock nut
9	S-6606	5/16 x 3/4 in. flange bolt
10	GK1726	Control gate clamp for SCH 40 x 1/2 in.
11	S-1937	5/16 in. flat washer SAE
12	S-3611	5/16 in. flange nut
13	S-9350	5/16 x 1-1/4 in. HHCS bolt
14	S-8397	5/16 x 1-3/4 in. spring pin
15	S-6076	5/16 x 3/4 in. carriage bolt

Auxiliary Kits (Optional)

Figure 7-4 10 in. Auxiliary kit (30 ft – 36 ft) – Exploded view

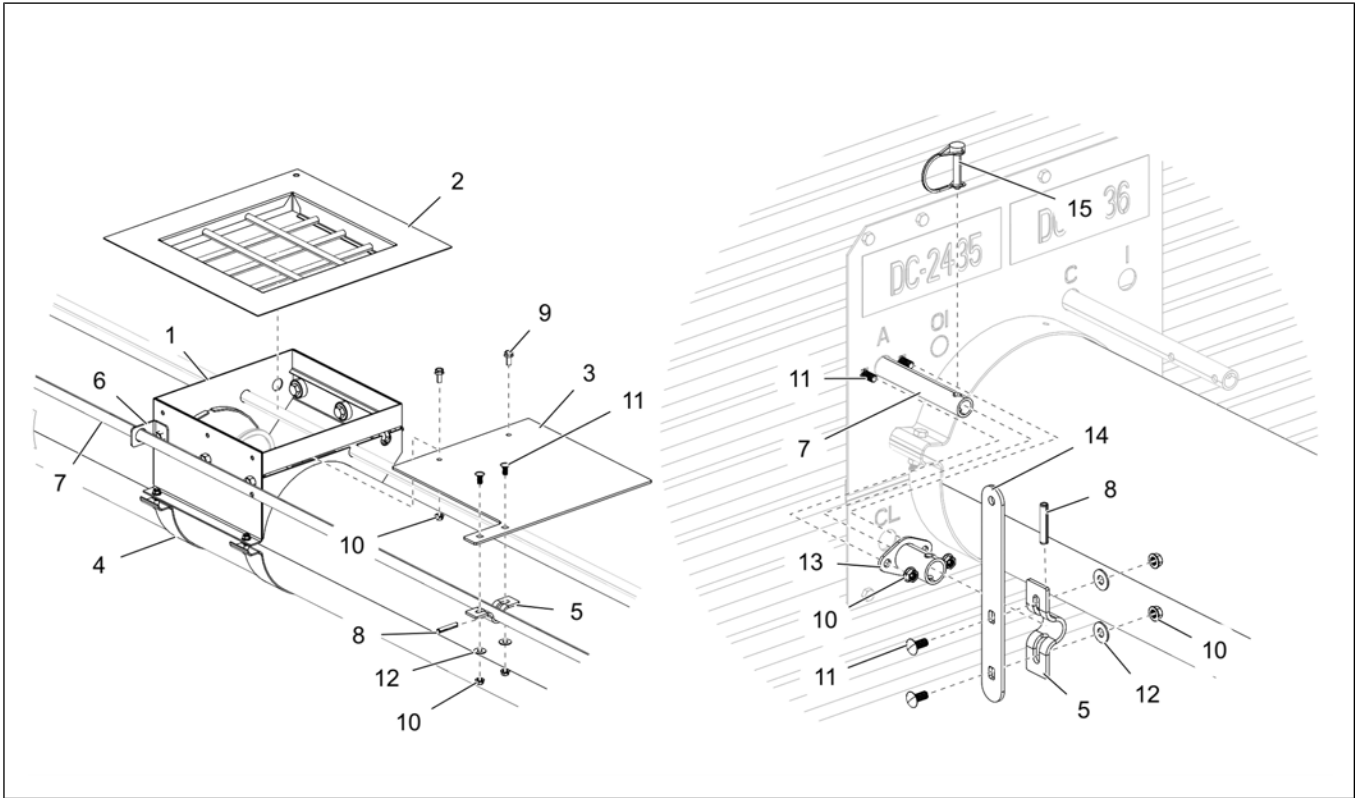

Figure 7-5 10 in. Auxiliary kit (42 ft – 48 ft) – Exploded view

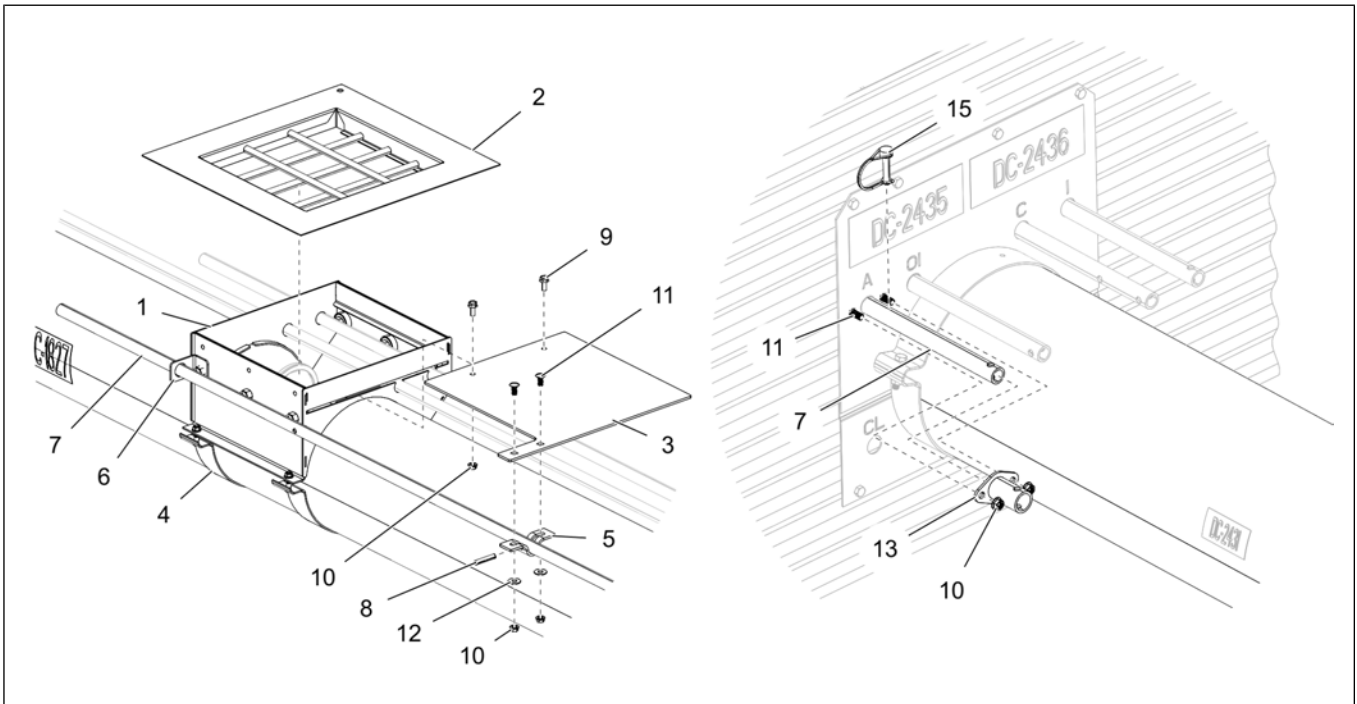

Table 7-4 Auxiliary kits (30 ft – 48 ft) – Parts list

Ref #	Part #	Description
1	GK80554-Y	Intermediate well weldment – 10 in. ochre
2	GK80561-Y	Intermediate well top flange – 10 in. ochre
3	GK80560	Auxiliary well gate – 10 in.
4	GK1057	Half band, 10 in. x 2 in. 12 ga. galv.
5	GK1726	Control gate clamp for SCH 40 x 1/2 in.
6	GK80559	Auxiliary well control rod guide
7	See table below	Auxiliary well control rod
8	S-8397	5/16 x 1-3/4 in. spring pin
9	S-6606	5/16 x 3/4 in. flange bolt
10	S-3611	5/16 in. flange nut
11	S-6076	5/16 x 3/4 in. carriage bolt
12	S-1937	5/16 in. flat washer SAE
13	GK80613-BS	Auxiliary well lock collar
14	GC12074	Auxiliary clutch control rod handle
15	S-10547	5/16 x 1-3/8 in. safety snap pin

Table 7-5 Auxiliary well control rod

Ref #	Part #	Description
7	GK80633	Auxiliary well control rod – 30 Ft
	GK80634	Auxiliary well control rod – 33 Ft
	GK80635	Auxiliary well control rod – 36 Ft
	GK80752	Auxiliary well control rod – 42 Ft
	GK80753	Auxiliary well control rod – 48 Ft

Chapter 7: Parts List

Figure 7-6 10 in. Auxiliary kit (54 ft – 72 ft) – Exploded view

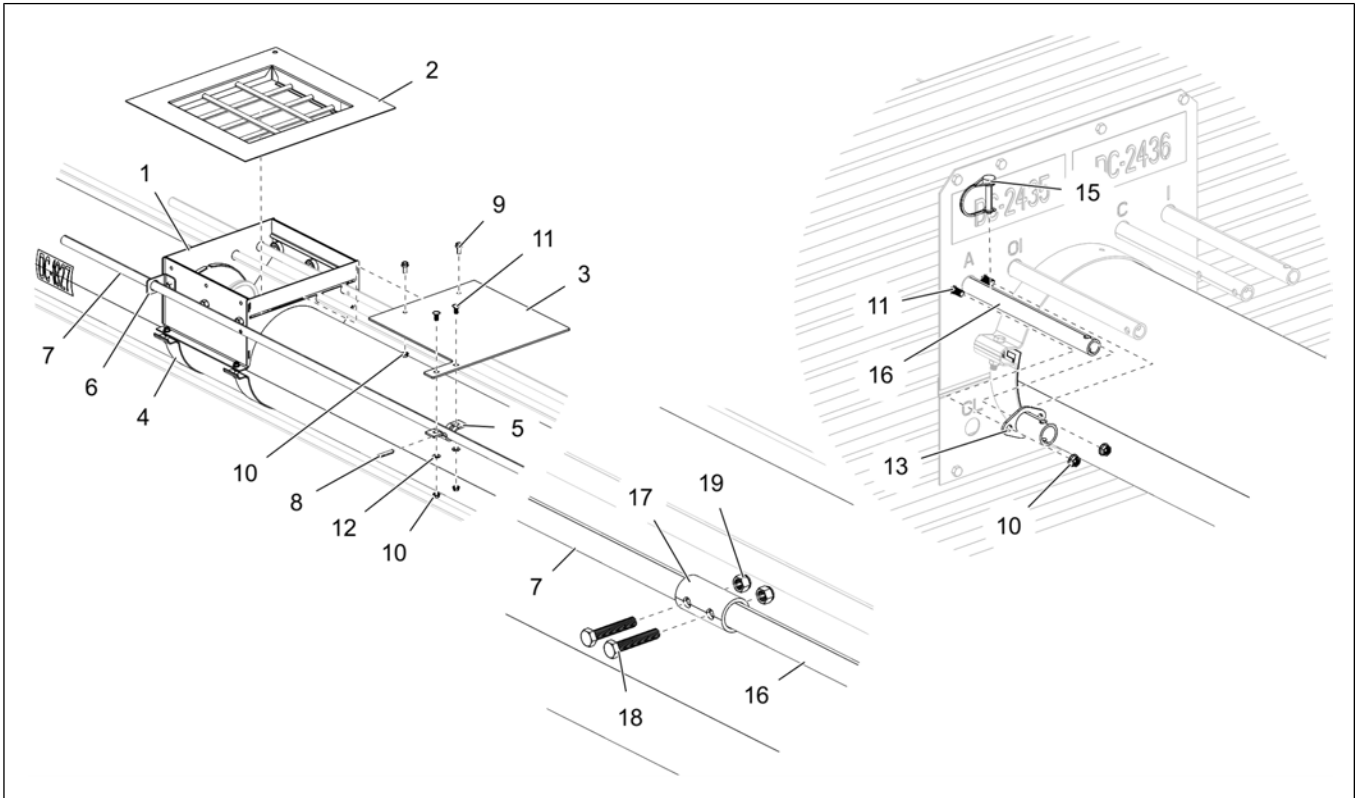

Table 7-6 Auxiliary kits (54 ft – 72 ft) – Parts list

Ref #	Part #	Description
1	GK80554-Y	Intermediate well weldment – 10 in. ochre
2	GK80561-Y	Intermediate well top flange – 10 in. ochre
3	GK80560	Auxiliary well gate – 10 in.
4	GK1057	Half band, 10 in. x 2 in. 12 ga. galv.
5	GK1726	Control gate clamp for SCH 40 x 1/2 in.
6	GK80559	Auxiliary well control rod guide
7	See table below	Auxiliary well control rod
8	S-8397	5/16 x 1-3/4 in. spring pin
9	S-6606	5/16 x 3/4 in. flange bolt
10	S-3611	5/16 in. flange nut
11	S-6076	5/16 x 3/4 in. carriage bolt
12	S-1937	5/16 in. flat washer SAE
13	GK80613-BS	Auxiliary well lock collar
15	S-10547	5/16 x 1-3/8 in. safety snap pin
16	See table below	Auxiliary well control rod extension
17	GK80532-BS	Clutch control rod coupling bin silver
18	S-7149	5/16 x 1-3/4 in. HHTB bolt
19	S-7382	5/16 in. nylock nut

Table 7-7 Auxiliary well control rod

Ref #	Bin Dia (Ft)	Part #	Description
7	54, 60	GK80761	Auxiliary well control rod – 54 Ft
	66	GK80765	Clutch control rod extension – 72 Ft
	72	GK80785	Auxiliary well control rod – 66 Ft
16	54	GK80759	Intermediate well control rod extension IS – 54 Ft
	60	GK80777	Intermediate well control rod extension IS – 60 Ft
	66	GK80783	Intermediate well control rod extension IS – 66 Ft
	72	GK80793	Auxiliary well control rod extension – 72 Ft

Single Rack and Pinion (30 Ft — 36 Ft)

Figure 7-7 Single rack and pinion (30 ft –36 ft) – Exploded view

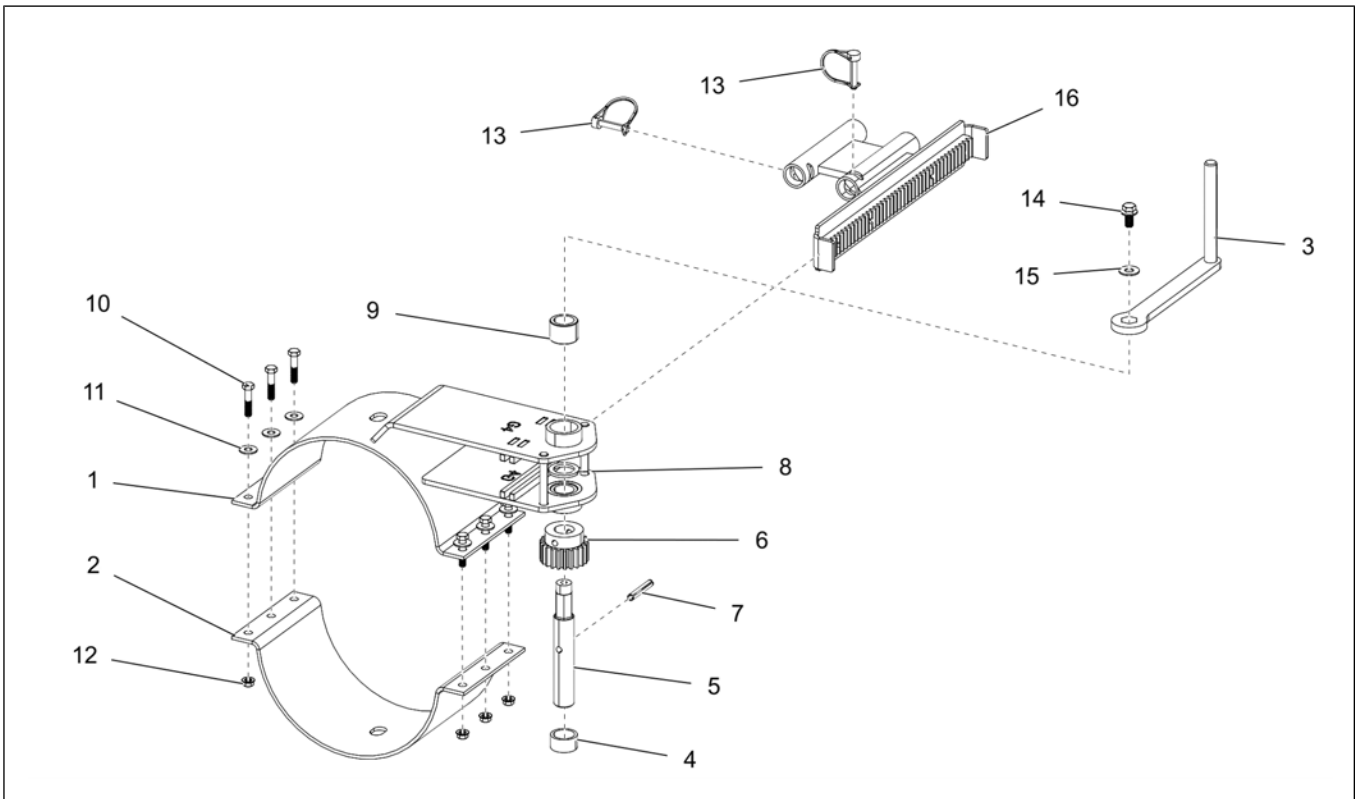

Table 7-8 Single rack and pinion (30 ft –36 ft) – Parts list

Ref #	Part #	Description
1	GK80567-BS	Rack and pinion housing weldment – 10 in. bin silver
2	GK1509-BS	10 in. x 6 in. 7 ga. half band – 10 in. bin silver
3	GK80404-BS	Crank gate weldment painted
4	GK6841	Rack and pinion spacer tube
5	GK6845	Rack and pinion crank shaft hex
6	GC09859	Gear, spur 10 DP 14.5 PA 1 in. F x 22T Martin #S1022; 1 in. bore w/ 0.313 pin hole
7	S-4377	5/16 x 2 in. spring pin
8	GK4211	1 x 1-1/2 in. 10 ga. ZN flat washer
9	GK1070	Bronze bushing 1.377 x 1.013 ID x 1 in. L
10	S-2741	5/16 x 1-1/2 in. bolt
11	S-845	5/16 in. flat washer
12	S-3611	5/16 in. flange nut
13	S-10547	5/16 x 1-3/8 in. safety snap pin
14	S-9067	3/8 x 3/4 in. flange bolt
15	S-248	3/8 in. 7/16 in. ID 1 in. OD flat washer
16	GK80568	Rack bar assembly – 10 in.

Double Rack and Pinion (42 Ft — 72 Ft)

Figure 7-8 Double rack and pinion – Exploded view

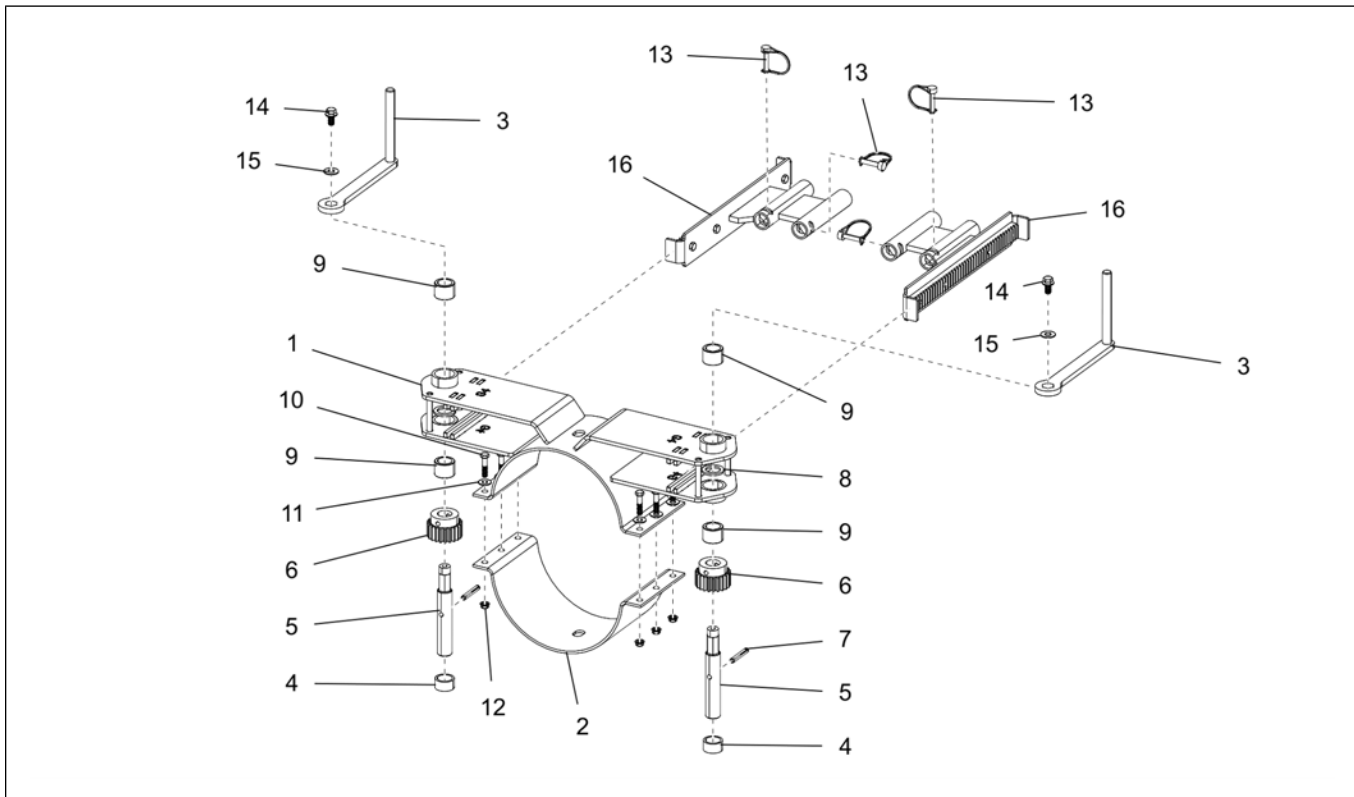

Table 7-9 Double rack and pinion (42 ft – 72 ft) – Parts list

Ref #	Part #	Description
1	GK80573-BS	Double rack and pinion housing weldment – 10 in. bin silver
2	GK1509-BS	10 in. x 6 in. 7 ga. half band – 10 in. bin silver
3	GK80404-BS	Crank gate weldment painted
4	GK6841	Rack and pinion spacer tube
5	GK6845	Rack and pinion crank shaft hex
6	GC09859	Gear, spur 10 DP 14.5 PA 1 in. F x 22T Martin #S1022; 1 in. bore w/ 0.313 pin hole
7	S-4377	5/16 x 2 in. spring pin
8	GK4211	1 x 1-1/2 in. 10 ga. ZN flat washer
9	GK1070	Bronze bushing 1.377 x 1.013 ID x 1 in. L
10	S-2741	5/16 x 1-1/2 in. bolt
11	S-845	5/16 in. flat washer
12	S-3611	5/16 in. flange nut
13	S-10547	5/16 x 1-3/8 in. safety snap pin
14	S-9067	3/8 x 3/4 in. flange bolt
15	S-248	3/8 in. 7/16 in. ID 1 in. OD flat washer
16	GK80568	Rack bar assembly – 10 in.

Bin Flange

Figure 7-9 10 in. Bin flange – Exploded view

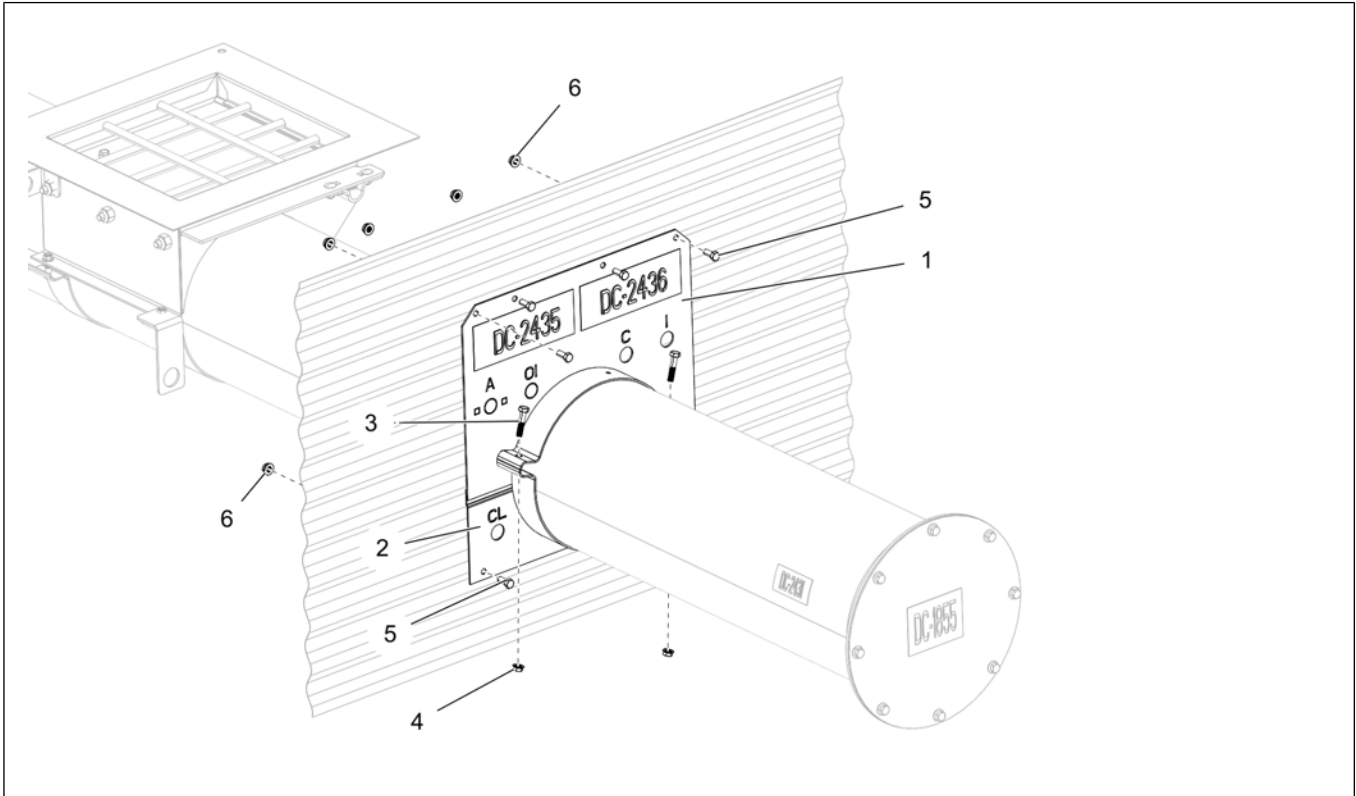

Table 7-10 Bin flange – Parts list

Ref #	Part #	Description
1	GK80595	Top wall flange – 10 in.
2	GK80596	Bottom wall flange – 10 in.
3	S-2741	5/16 x 1-1/2 in. HHCS bolt
4	S-3611	5/16 in. flange nut
5		Standard bin bolt
6		Flange nut

Sweep Wheel

Figure 7-10 Sweep wheel – Exploded view

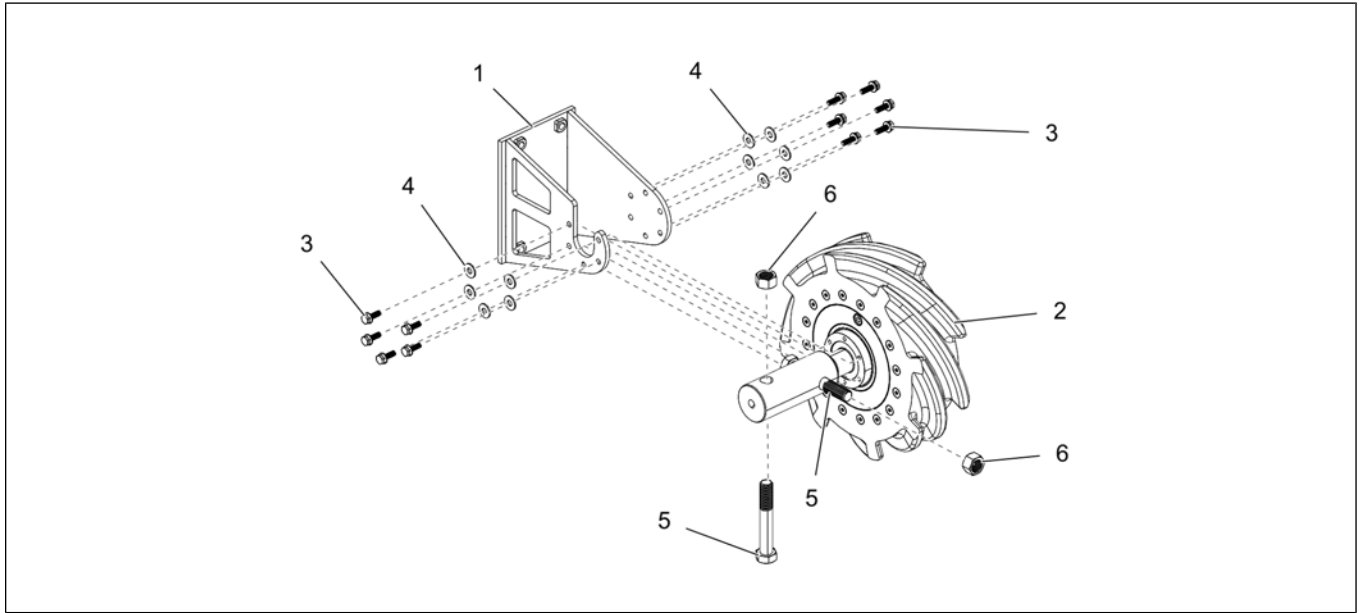

Table 7-11 Sweep wheel – Parts list

Ref #	Part #	Description
1	GK80714-Y	Wheel housing weldment – 10 in. HD
2	GK80627	Sweep wheel 10.875 in. x 8.5:1 ratio
3	S-8680	1/4 in. flange bolt
4	S-1430	1/4 in flat washer
5	S-7893	5/8 x 4 in. HHCS bolt
6	S-8606	5/8 in. stover nut

Unload Tube Flight

Figure 7-11 Unload tube flight (30 ft – 36 ft) – Exploded view

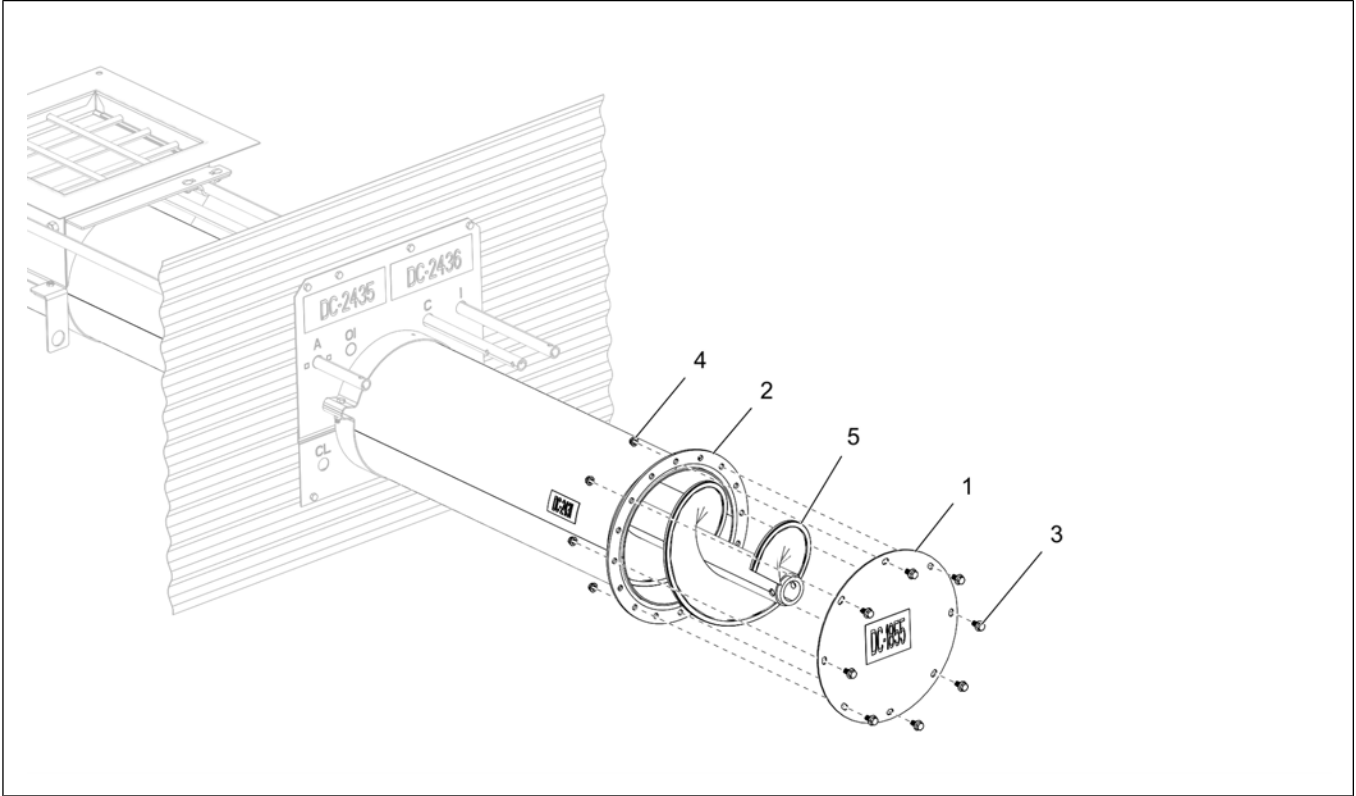

Figure 7-12 Unload tube flight (42 ft – 48 ft) – Exploded view

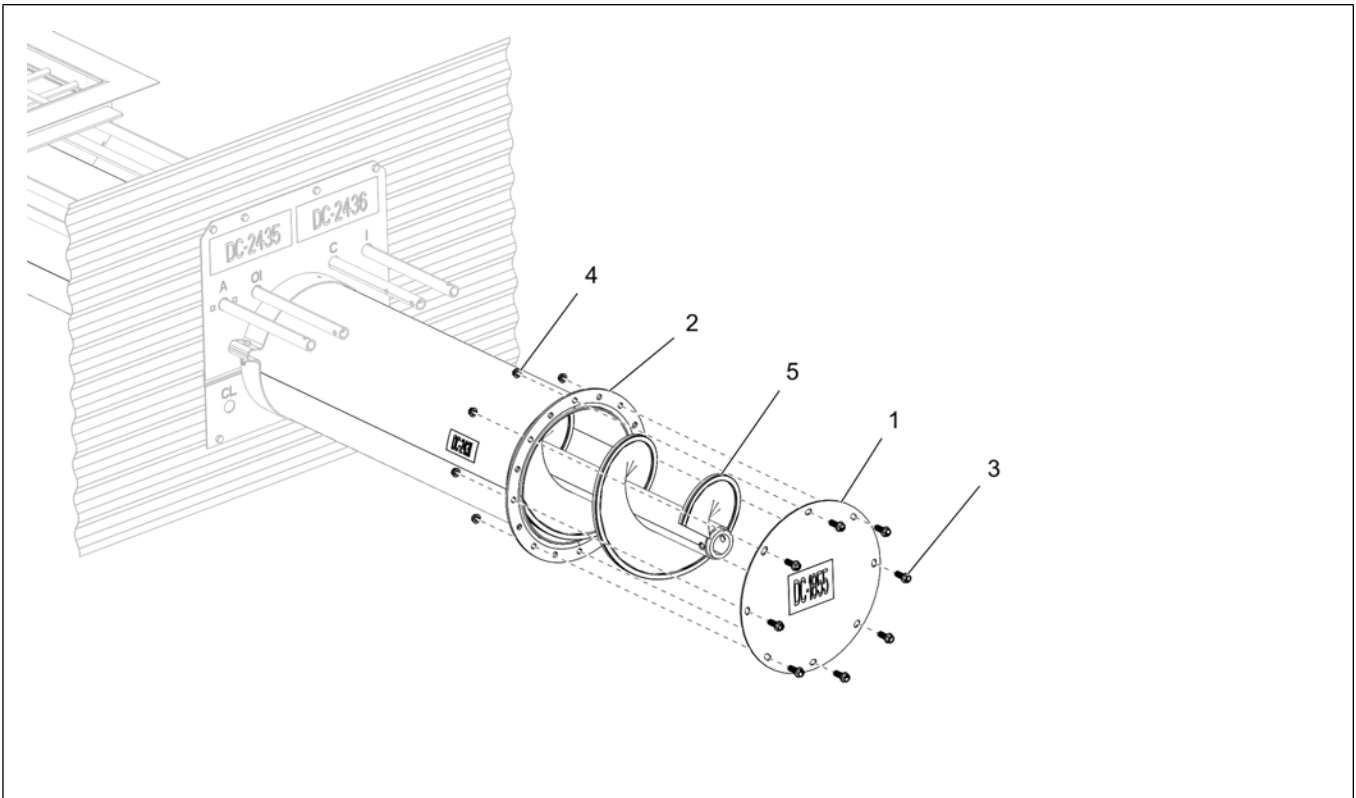

Table 7-12 *Unload tube flight (30 ft – 48 ft) – Parts list*

Ref #	Part #	Description
1	GK2184	End cap – 10 in.
2	See table below	Tube weldment – 10 in.
3	S-10260	5/16 x 3/4 in. flange bolt
4	S-3611	5/16 in. flange nut
5	See table below	Flight weldment – 10 in.

Table 7-13 *Tube weldment*

Ref #	Bin Dia (Ft)	Part #	Description
2	30	GK80549	Tube weldment – 10 in. x 30 Ft
	33	GK80550	Tube weldment – 10 in. x 33 Ft
	36	GK80551	Tube weldment – 10 in. x 36 Ft
	42	GK80552	Tube weldment – 10 in. x 42 Ft
	48	GK80553	Tube weldment – 10 in. x 48 Ft

Table 7-14 *Flight weldment*

Ref #	Bin Dia (Ft)	Part #	Description
5	30	GK80754	Flight weldment 200.125 in. – 10 in. x 30 Ft
	33	GK80755	Flight weldment 218.125 in. – 10 in. x 33 Ft
	36	GK80756	Flight weldment 236.125 in. – 10 in. x 36 Ft
	42	GK80757	Flight weldment 272.125 in. – 10 in. x 42 Ft
	48	GK80758	Flight weldment 308.125 in. – 10 in. x 48 Ft

Chapter 7: Parts List

Figure 7-13 Unload tube flight (54 ft – 66 ft) – Exploded view

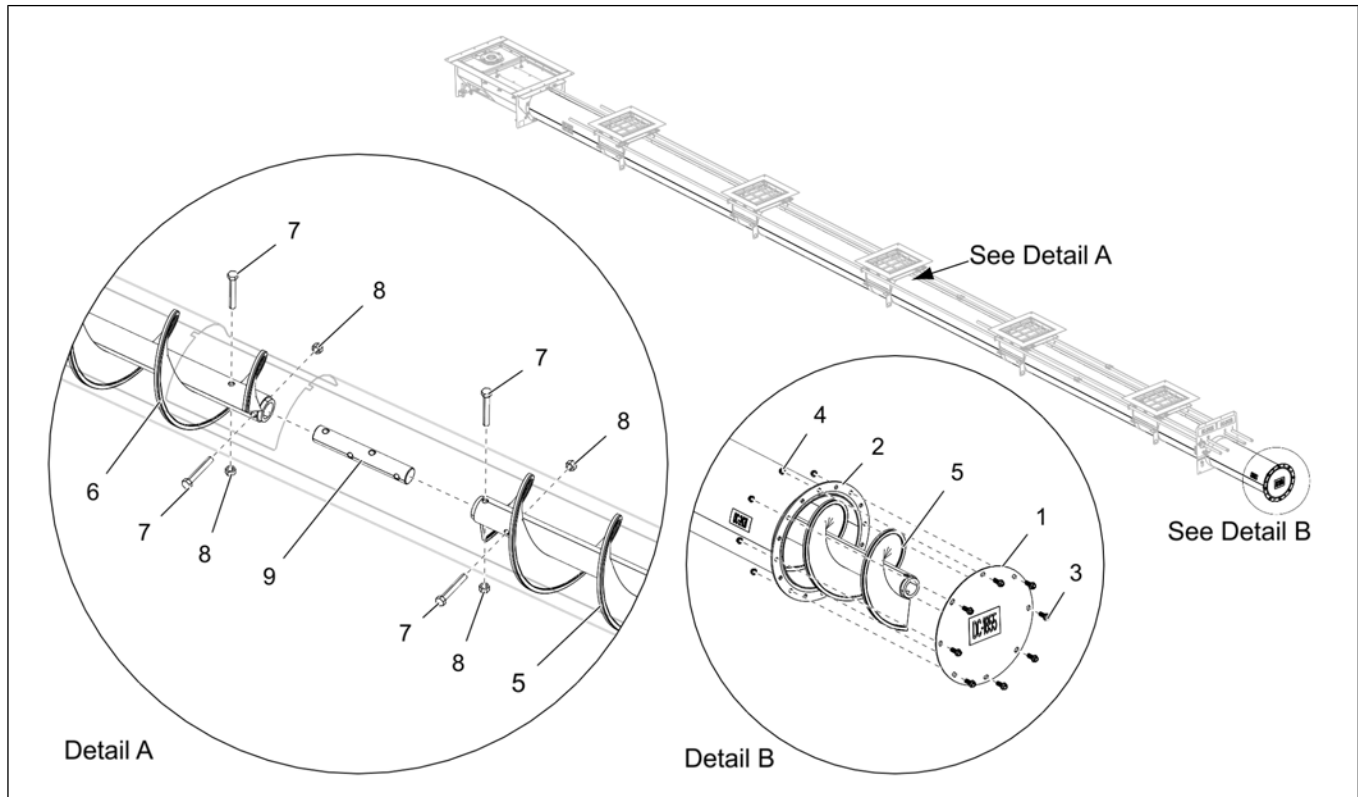

Table 7-15 Unload tube flight (54 ft – 66 ft) Parts list

Ref #	Part #	Description
1	GK2184	End cap – 10 in.
2	See table below	Tube weldment – 10 in.
3	S-10260	5/16 x 3/4 in. flange bolt
4	S-3611	5/16 in. flange nut
5	See table below	Flight weldment – 10 in.
6	See table below	Flight weldment extension – 10 in.
7	S-8314	1/2 x 3-1/2 in. HHCS bolt
8	S-8315	1/2 in. lock nut
9	GK1339	1.5 in. OD x 9.5 in. connecting shaft

Table 7-16 Tube weldment

Ref #	Bin Dia (Ft)	Part #	Description
2	54	GK80743	Tube weldment – 10 in. x 54 Ft
	60	GK80744	Tube weldment – 10 in. x 60 Ft
	66	GK80745	Tube weldment – 10 in. x 66 Ft

Table 7-17 Flight weldment

Ref #	Bin Dia (Ft)	Ref # 5	Description
5	54, 60, 66	GK80754	Flight weldment 200.125 in. – 10 in. x 30 Ft
6	54	GK80816	Flight weldment 143.750 in. – 10 in. x 54 Ft
	60	GK80815	Flight weldment 179.750 in. – 10 in. x 60 Ft
	66	GK80814	Flight weldment 215.750 in. – 10 in. x 66 Ft

Figure 7-14 Unload tube flight (72 ft) – Exploded view

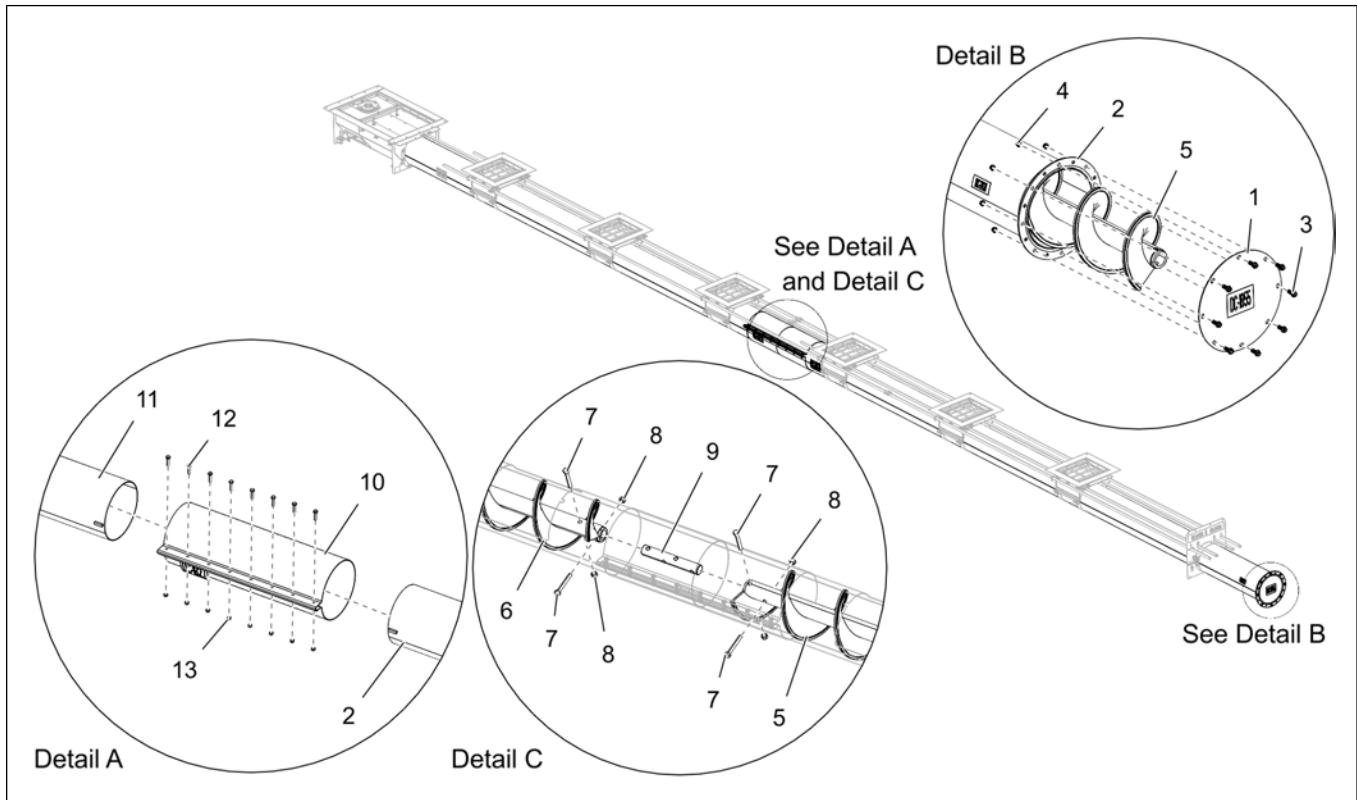

Table 7-18 Unload tube flight (72 ft) Parts list

Ref #	Part #	Description
1	GK2184	End cap – 10 in.
2	GK80746	Tube weldment – 10 in. x 72 ft IS
3	S-10260	5/16 x 3/4 in. flange bolt
4	S-3611	5/16 in. flange nut
5	GK80754	Flight weldment 200.125 in. – 10 in. x 30 Ft
6	GK80813	Flight weldment 253.750 in. – 10 in. x 72 Ft
7	S-8314	1/2 x 3-1/2 in. HHCS bolt
8	S-8315	1/2 in. lock nut
9	GK1339	1.5 in. OD x 9.5 in. connecting shaft
10	GK1883	10 in. x 30 in. connecting band
11	GK80747	Tube weldment – 10 in. x 72 ft OS
12	S-10275	3/8 x 1-1/2 in. HHCS bolt
13	S-8251	3/8 in. stover nut

Clutch Control

Figure 7-15 Clutch control – Exploded view

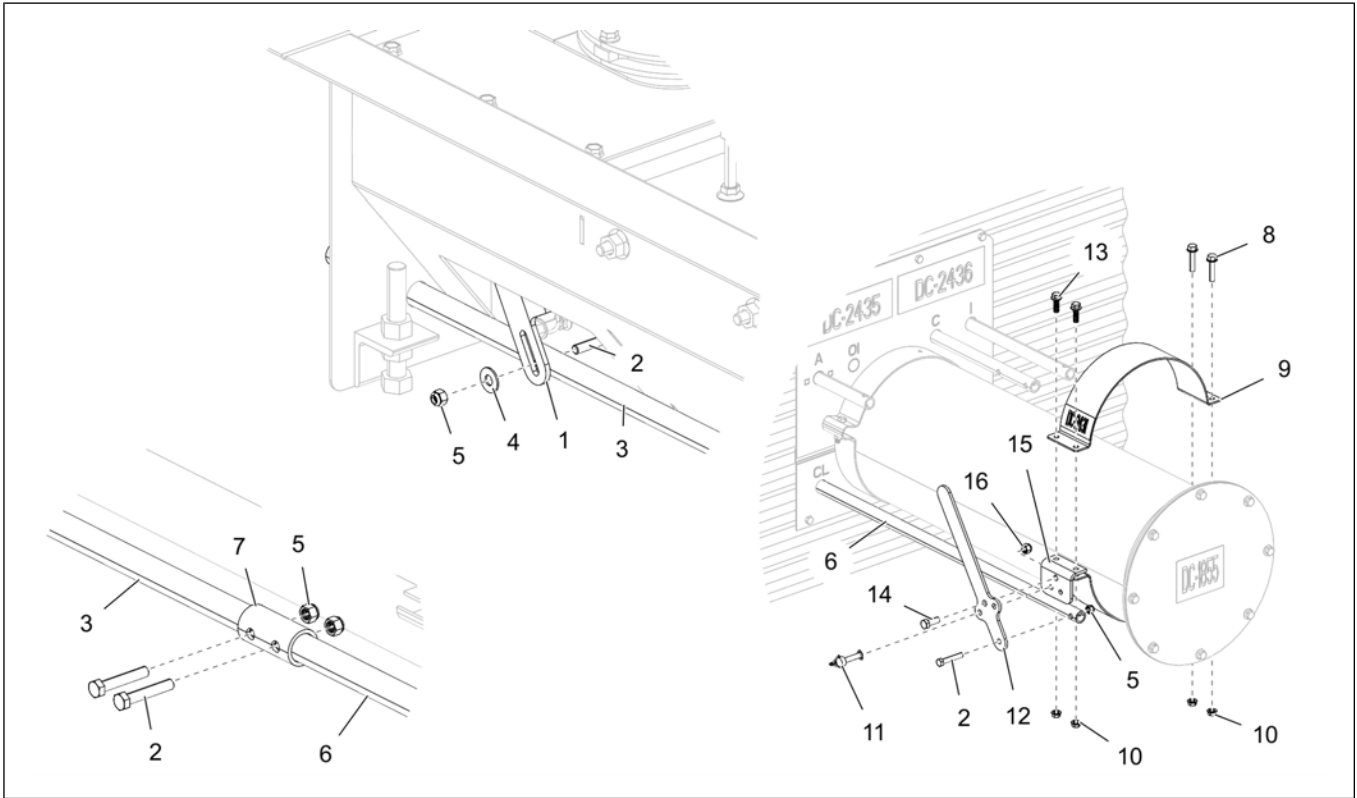

Table 7-19 *Clutch control – Parts list*

Ref #	Part #	Description
1	GK80541	Center well linkage plate – 10 in.
2	S-7149	5/16 x 1-3/4 in. HHTB bolt
3	See table below	Clutch control rod
4	S-845	5/16 in. flat washer
5	S-7382	5/16 in. nylock nut
6	See table below	Clutch control rod extension
7	GK80532-BS	Clutch control rod coupling bin silver (42 ft to 72 ft)
8	S-10185	5/16 x 1-1/2 in. flange bolt
9	GK80562	Half band, 10 in. x 3 in. 12 ga. galv.
10	S-3611	5/16 in. flange nut
11	S-10547	5/16 x 1-3/8 in. safety snap pin
12	GK80390	Clutch handle
13	S-7470	5/16 x 1 in. flange bolt
14	S-7469	3/8 x 1 in. HHCS bolt
15	GK80389	Clutch pivot handle
16	S-7383	3/8 in. nylock nut

Table 7-20 *Clutch control rod*

Ref #	Part #	Description
3	GK80456	Clutch control rod – 30 ft
	GK80457	Clutch control rod – 33 ft
	GK80458	Clutch control rod – 36 ft
	GK80458	Clutch control rod – 42 ft to 72 ft

Table 7-21 *Clutch control rod extension*

Ref #	Part #	Description
6	GK80459	Clutch control rod extension – 42 ft
	GK80460	Clutch control rod extension – 48 ft
	GK80762	Clutch control rod extension – 54 ft
	GK80763	Clutch control rod extension – 60 ft
	GK80764	Clutch control rod extension – 66 ft
	GK80765	Clutch control rod extension – 72 ft

Backshield with Two Augers for Standard Sweeps (30 Ft Bins)

Figure 7-16 Backshield with two augers – Exploded view

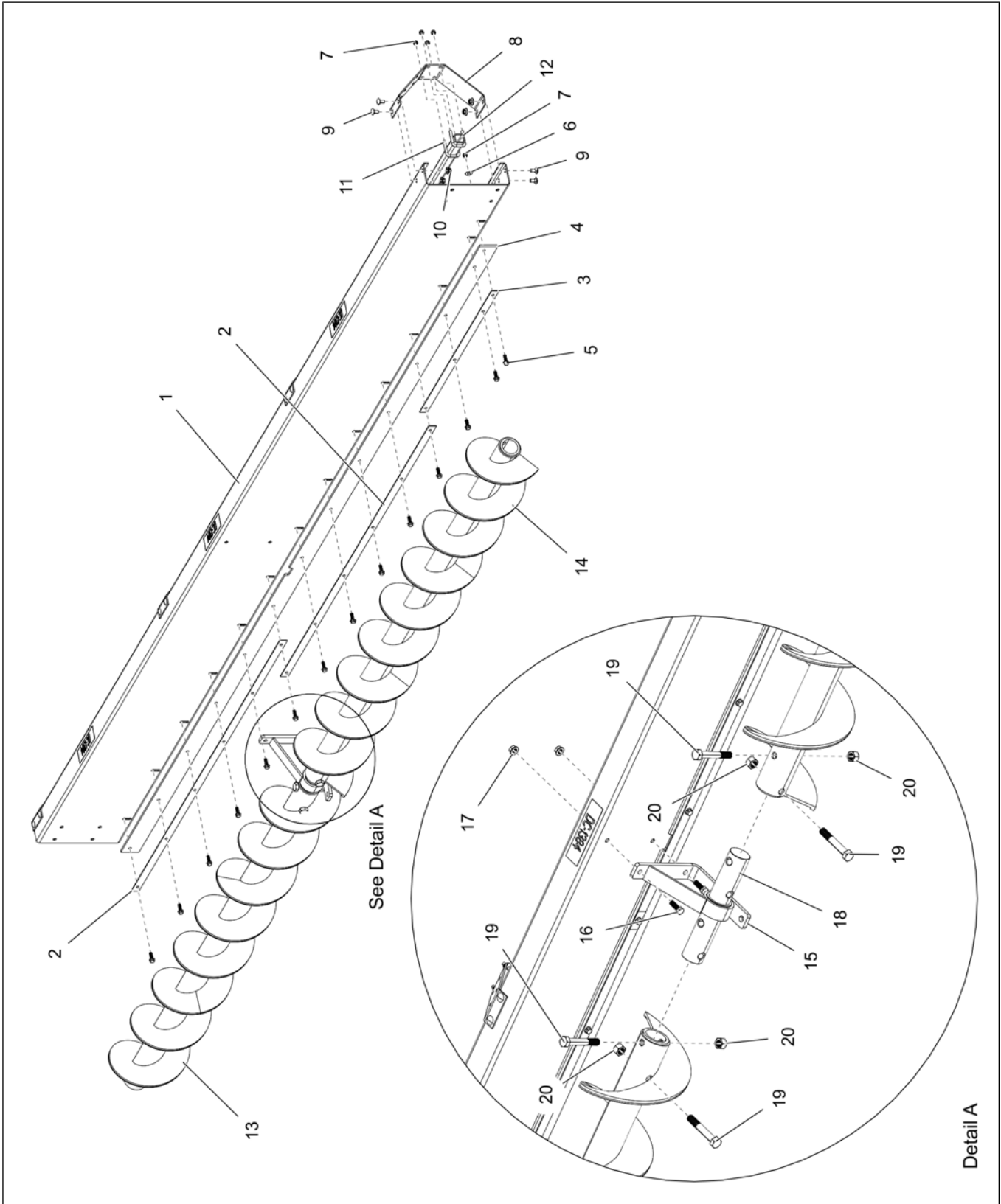

Table 7-22 Backshield with two augers – Parts list

Ref #	Part #	Description
1	GK80693	Backshield – 10 in. x 30 ft bin
2	GK80534	Wiper retainer standard – 30 ft to 72 ft bins
3	GK80489	Wiper retainer – 30 ft bins
4	GK80500	Backshield wiper – 30 ft bin
5	S-7470	5/16 x 1 in. flange bolt
6	S-845	5/16 in. flat washer
7	S-7382	5/16 in. nylock nut
8	GK80715	Torque tube bracket
9	S-7391	3/8 x 3/4 in. carriage bolt
10	S-968	3/8 in. flange nut
11	S-10521	U-bolt
12	GK80478	Torque tube – 30 ft bin
13	GK80727	9 in. x 6 ft. 1.50 in. 1/4 in. flight weldment standard
14	GK80728	9 in. x 6 ft. 9.25 in. 1/4 in. flight weldment – 30 ft bin
15	GK80711	Hanger bracket assembly – 10 in. HD
16	S-3886	7/16 x 1-1/4 in. HHCS bolt
17	S-9073	7/16 in. flange nut
18	GK2222	2 in. OD x 11.5 in. connecting shaft
19	S-7893	5/8 x 4 in. HHCS bolt
20	S-8606	5/8 in. stover nut

Backshield with Two Augers for Short Sweeps (30 Ft Bins)

Figure 7-17 Backshield with two augers for short sweeps – Exploded view

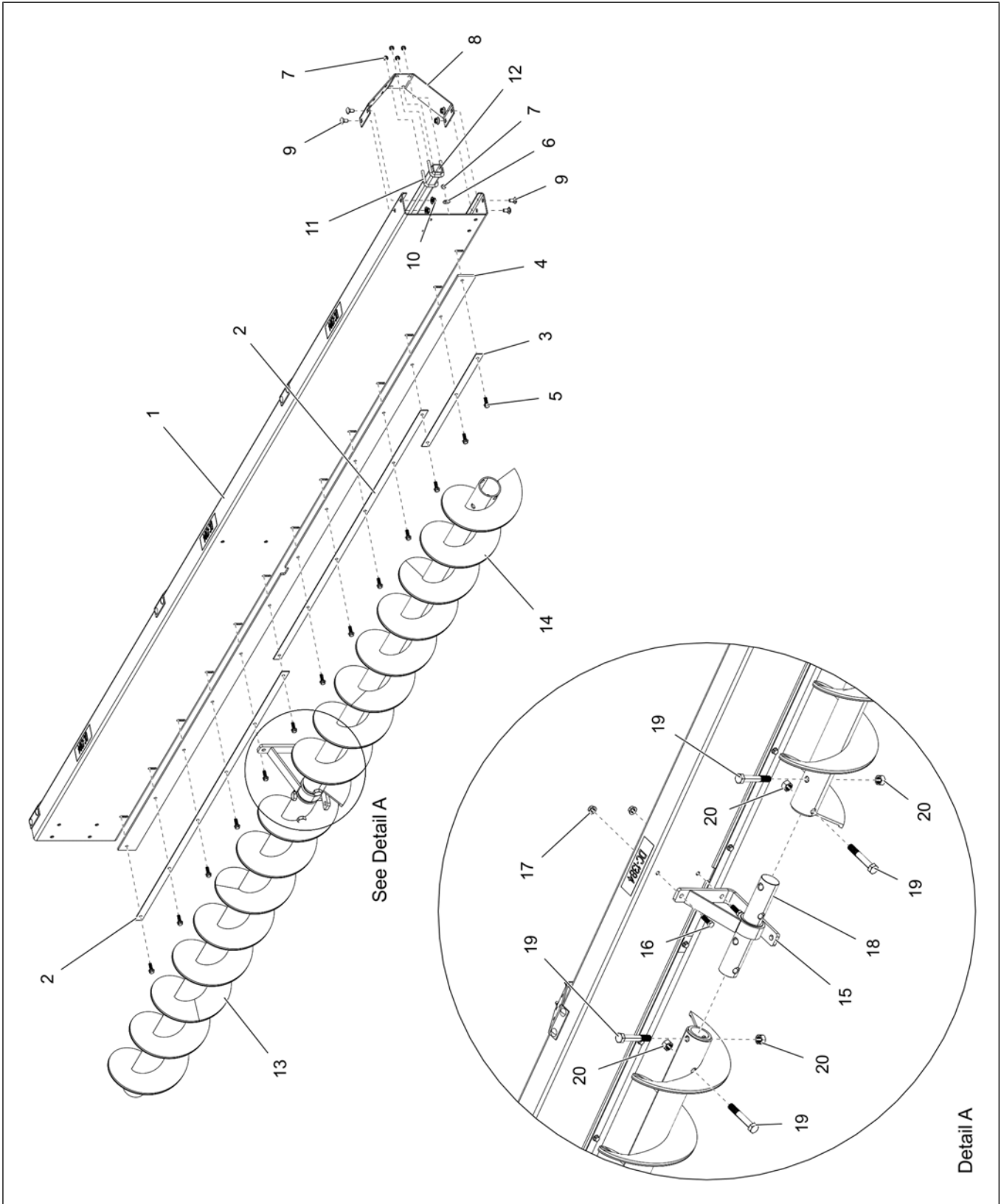

Table 7-23 Backshield with two augers for short sweeps – Parts list

Ref #	Part #	Description
1	GK80850	Backshield – 10 in. x 30 ft bin – short
2	GK80534	Wiper retainer extension standard – 30 ft to 72 ft bins
3	GK80680	Wiper retainer – 30 ft bin – short
4	GK80675	Backshield wiper – 30 ft bin – short
5	S-7470	5/16 x 1 in. flange bolt
6	S-845	5/16 in. flat washer
7	S-7382	5/16 in. nylock nut
8	GK80715	Torque tube bracket
9	S-7391	3/8 x 3/4 in. carriage bolt
10	S-968	3/8 in. flange nut
11	S-10521	U-bolt
12	GK80665	Torque tube – 30 ft bin – short
13	GK80727	9 in. x 6 ft. 1.50 in. 1/4 in. flight weldment standard
14	GK80822	9 in. x 6 ft. 2.25 in. 1/4 in. flight weldment – short
15	GK80711	Hanger bracket assembly – 10 in. HD
16	S-3886	7/16 x 1-1/4 in. HHCS bolt
17	S-9073	7/16 in. flange nut
18	GK2222	2 in. OD x 11.5 in. connecting shaft
19	S-7893	5/8 x 4 in. HHCS bolt
20	S-8606	5/4 in. stover nut

Backshield with Three Augers for Standard Sweeps (33 Ft – 42 Ft Bins)

Figure 7-18 Backshield with three augers – Exploded view

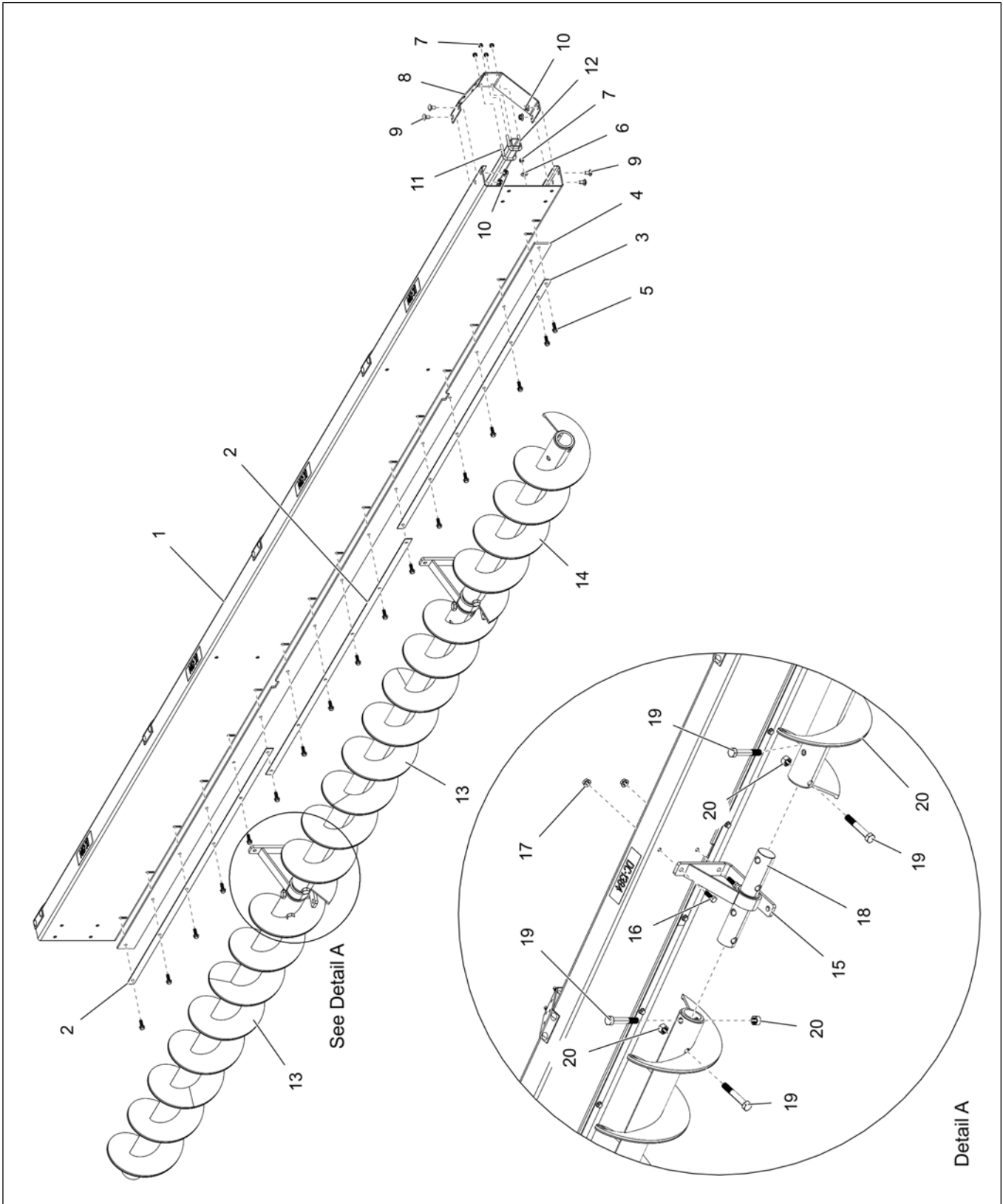

Table 7-24 Backshield with three augers – Parts list

Ref #	Part #	Description
1	GK80694	Backshield – 10 in. x 33 ft bin
	GK80695	Backshield – 10 in. x 36 ft bin
	GK80696	Backshield – 10 in. x 42 ft bin
2	GK80534	Wiper retainer standard – 30 ft to 72 ft bins
3	GK80490	Wiper retainer – 33 ft bin
	GK80491	Wiper retainer – 36 ft bin
	GK80492	Wiper retainer – 42 ft bin
4	GK80501	Backshield wiper – 33 ft bin
	GK80502	Backshield wiper – 36 ft bin
	GK80503	Backshield wiper – 42 ft bin
5	S-7470	5/16 x 1 in. flange bolt
6	S-845	5/16 in. flat washer
7	S-7382	5/16 in. nylock nut
8	GK80715	Torque tube bracket
9	S-7391	3/8 x 3/4 in. carriage bolt
10	S-968	3/8 in. flange nut
11	S-10521	U-bolt
12	GK80479	Torque tube – 33 ft bin
	GK80480	Torque tube – 36 ft bin
	GK80481	Torque tube – 42 ft bin
13	GK80727	9 in. x 6 ft. 1.50 in. 1/4 in. flight weldment standard
14	GK80729	9 in. x 1 ft. 11.50 in. 1/4 in. flight weldment – 33 ft bin
	GK80730	9 in. x 3 ft. 5.00 in. 1/4 in. flight weldment – 36 ft bin
	GK80731	9 in. x 6 ft. 4.50 in. 3/16 in. flight weldment – 42 ft bin
15	GK80711	Hanger bracket assembly – 10 in. HD
16	S-3886	7/16 x 1-1/4 in. HHCS bolt
17	S-9073	7/16 in. flange nut
18	GK2222	2 in. OD x 11.5 in. connecting shaft
19	S-7893	5/8 x 4 in. HHCS bolt
20	S-8606	5/8 in. stover nut

Backshield with Three Augers for Short Sweeps (33 Ft – 42 Ft Bins)

Figure 7-19 Backshield with three augers short sweeps – Exploded view

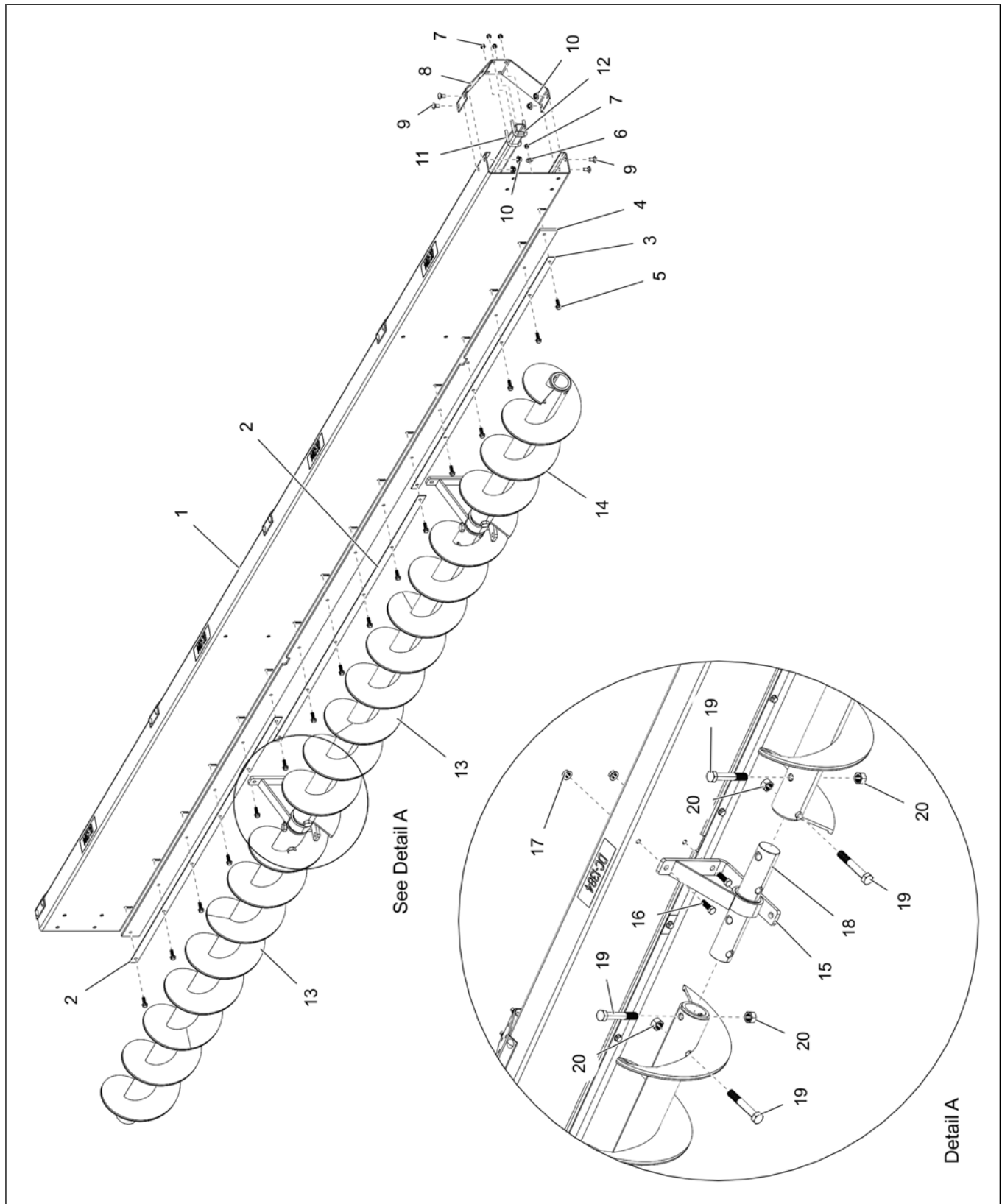

Table 7-25 Backshield with three augers for short sweeps – Parts list

Ref #	Part #	Description
1	GK80851	Backshield – 10 in. x 33 ft bin – short
	GK80852	Backshield – 10 in. x 36 ft bin – short
	GK80853	Backshield – 10 in. x 42 ft bin – short
2	GK80534	Wiper retainer standard – 30 ft to 72 ft bins
3	GK80681	Wiper retainer – 33 ft bin – short
	GK80682	Wiper retainer – 36 ft bin – short
	GK80859	Wiper retainer – 42 ft bin – short
4	GK80676	Backshield wiper – 33 ft bin – short
	GK80677	Backshield wiper – 36 ft bin – short
	GK80848	Backshield wiper – 42 ft bin – short
5	S-7470	5/16 x 1 in. flange bolt
6	S-845	5/16 in. flat washer
7	S-7382	5/16 in. nylock nut
8	GK80715	Torque tube bracket
9	S-7391	3/8 x 3/4 in. carriage bolt
10	S-968	3/8 in. flange nut
11	S-10521	U-bolt
12	GK80666	Torque tube – 33 ft bin – short
	GK80667	Torque tube – 36 ft bin – short
	GK80874	Torque tube – 42 ft bin – short
13	GK80727	9 in. x 6 ft. 1.50 in. 1/4 in. flight weldment standard
14	GK80823	9 in. x 1 ft. 4.50 in. 1/4 in. flight weldment – 33 ft bin – short
	GK80824	9 in. x 2 ft. 10 in. 1/4 in. flight weldment – 36 ft bin – short
	GK80825	9 in. x 5 ft. 8.5 in. 1/4 in. flight weldment – 42 ft bin – short
15	GK80711	Hanger bracket assembly – 10 in. HD
16	S-3886	7/16 x 1-1/4 in. HHCS bolt
17	S-9073	7/16 in. flange nut
18	GK2222	2 in. OD x 11.5 in. connecting shaft
19	S-7893	5/8 x 4 in. HHCS bolt
20	S-8606	5/8 in. stover nut

Backshield with Four Augers for Standard Sweeps (48 Ft and 54 Ft Bins)

Figure 7-20 Backshield with four augers (48 ft) – Exploded view

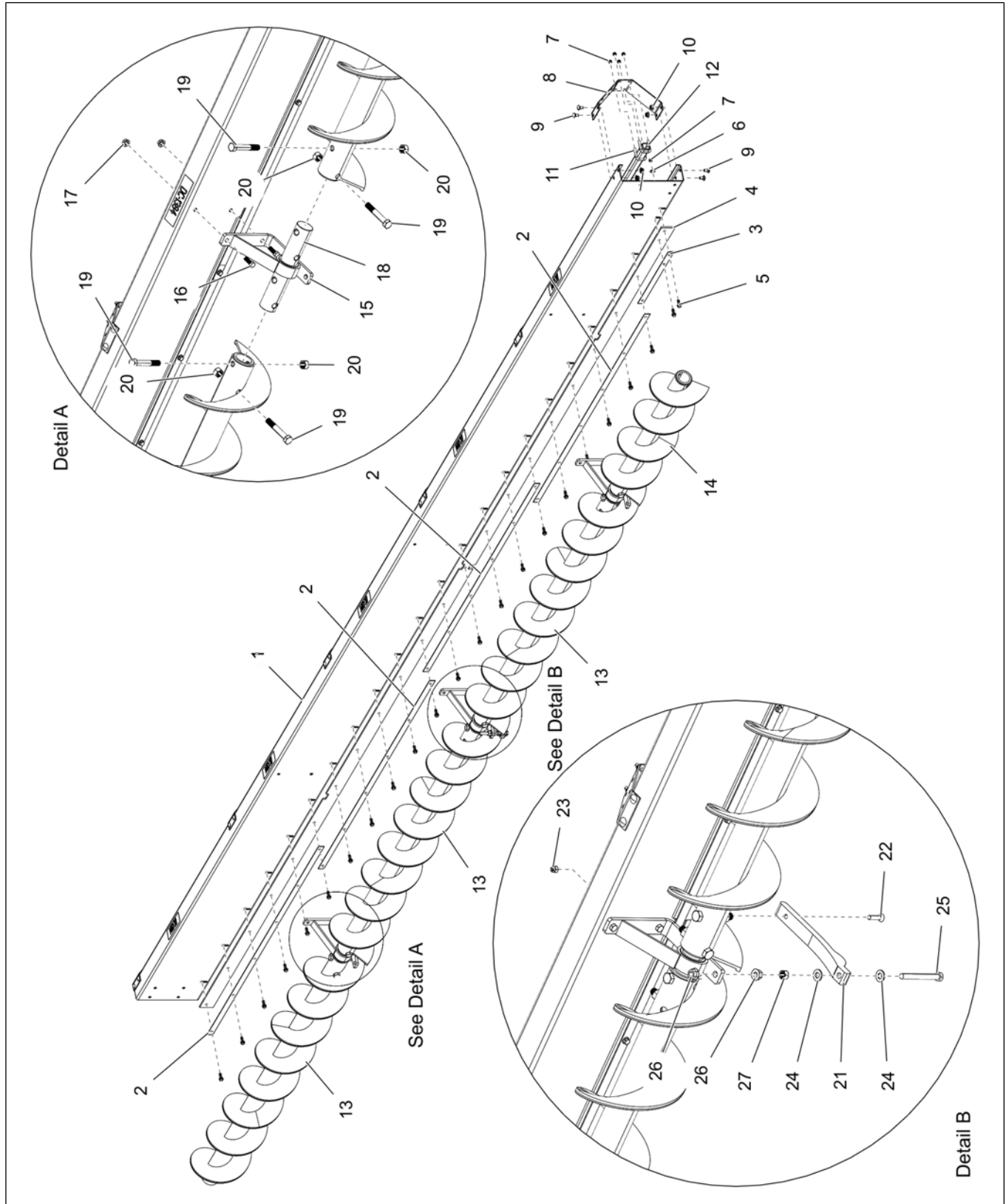

Table 7-26 Backshield with four augers (48 ft) – Parts list

Ref #	Part #	Description
1	GK80697	Backshield – 10 in. x 48 ft bin
2	GK80534	Wiper retainer standard – 30 ft to 72 ft bins
3	GK80493	Wiper retainer – 48 ft
4	GK80504	Backshield wiper – 48 ft bin
5	S-7470	5/16 x 1 in. flange bolt
6	S-845	5/16 in. flat washer
7	S-7382	5/16 in. nylock nut
8	GK80715	Torque tube bracket
9	S-7391	3/8 x 3/4 in. carriage bolt
10	S-968	3/8 in. flange nut
11	S-10521	U-bolt
12	GK80482	Torque tube – 48 ft bin
13	GK80727	9 in. x 6 ft. 1.50 in. 1/4 in. flight weldment standard
14	GK80732	9 in. x 3 ft. 0.75 in. 1/4 in. flight weldment – 48 ft bin
15	GK80711	Hanger bracket assembly – 10 in. HD
16	S-3886	7/16 x 1-1/4 in. HHCS bolt
17	S-9073	7/16 in. flange nut
18	GK2222	2 in. OD x 11.5 in. connecting shaft
19	S-7893	5/8 x 4 in. HHCS bolt
20	S-8606	5/8 in. stover nut
21	GK80725	Support skid
22	S-8255	3/8 x 1-1/2 in. screw
23	S-7383	3/8 in. nylock nut
24	S-2120	1/2 in. flat washer SAE
25	2FH1038	1/2 x 4-1/2 in. HHTB bolt
26	S-8506	1/2 in. flange nut
27	S-8315	1/2 in. stover nut

Figure 7-21 Backshield with four augers (54 ft) – Exploded view

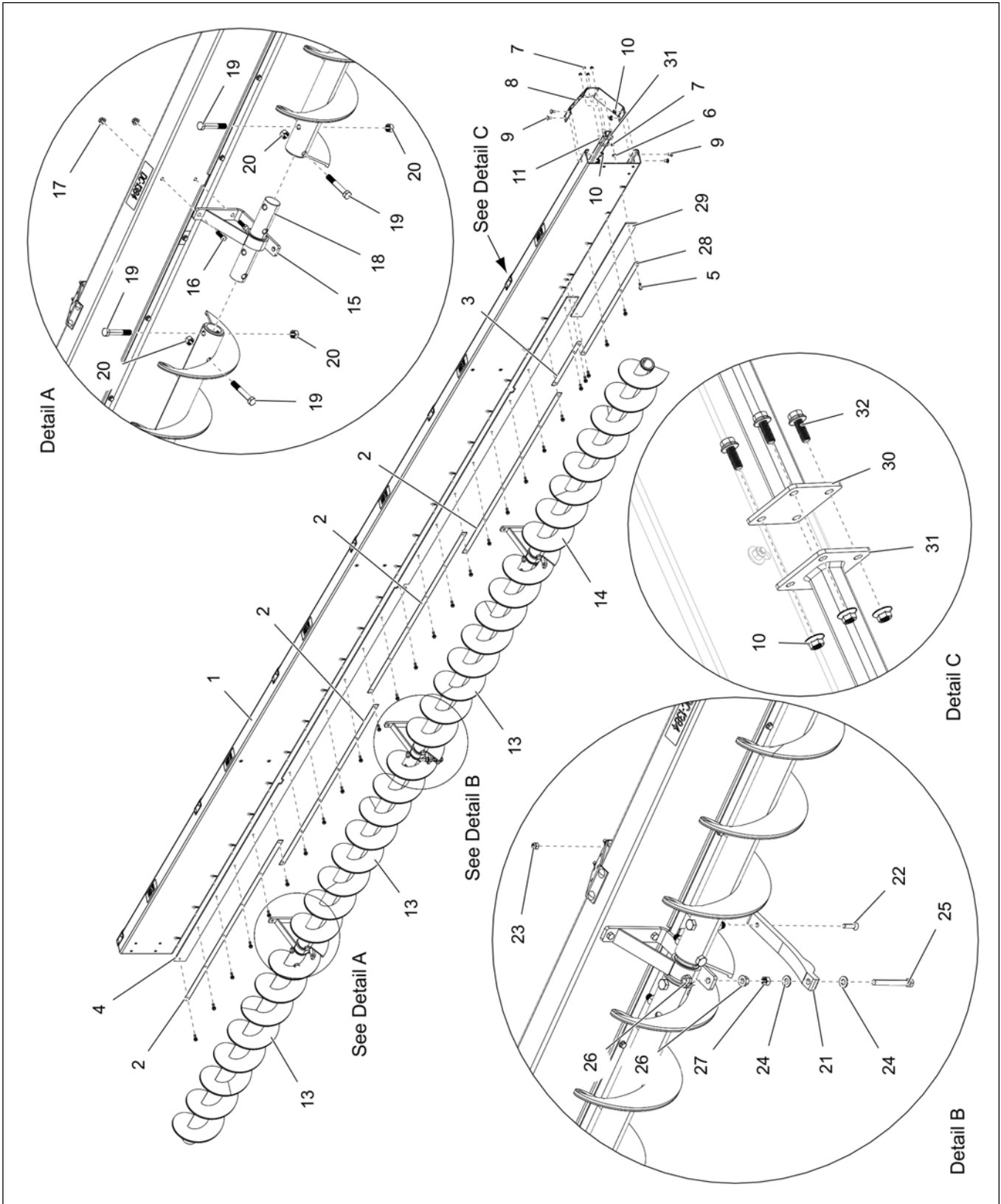

Table 7-27 Backshield with four augers (54 ft) – Parts list

Ref #	Part #	Description
1	GK80698	Backshield – 10 in. x 54 ft bin
2	GK80534	Wiper retainer standard – 30 ft to 72 ft bins
3	GK80493	Wiper retainer – 48 ft bin
4	GK80504	Backshield wiper – 48 ft bin
5	S-7470	5/16 x 1 in. flange bolt
6	S-845	5/16 in. flat washer
7	S-7382	5/16 in. nylock nut
8	GK80715	Torque tube bracket
9	S-7391	3/8 x 3/4 in. carriage bolt
10	S-968	3/8 in. flange nut
11	S-10521	U-bolt
13	GK80727	9 in. x 6 ft. 1.50 in. 1/4 in. flight weldment standard
14	GK80798	9 in. x 6 ft. 0.75 in. 1/4 in. flight weldment – 54 ft bin
15	GK80711	Hanger bracket assembly – 10 in. HD
16	S-3886	7/16 x 1-1/4 in. HHCS bolt
17	S-9073	7/16 in. flange nut
18	GK2222	2 in. OD x 11.5 in. connecting shaft
19	S-7893	5/8 x 4 in. HHCS bolt
20	S-8606	5/8 in. stover nut
21	GK80725	Support skid
22	S-8255	3/8 x 1-1/2 in. screw
23	S-7383	3/8 in. nylock nut
24	S-2120	1/2 in. flat washer SAE
25	2FH1038	1/2 x 4-1/2 in. HHTB bolt
26	S-8506	1/2 in. flange nut
27	S-8315	1/2 in. stover nut
28	GK80797	Wiper retainer extension – 54 ft bin
29	GK80772	Wiper extension – 54 ft bin
30	GK80768	Torque tube weldment standard – 54 ft bin
31	GK80769	Torque tube weldment – 54 ft bin
32	S-9065	3/8 x 1 in. flange bolt

Backshield with Four Augers Short Sweeps (48 Ft and 54 Ft Bins)

Figure 7-22 Backshield with four augers for short sweep (48 ft) – Exploded view

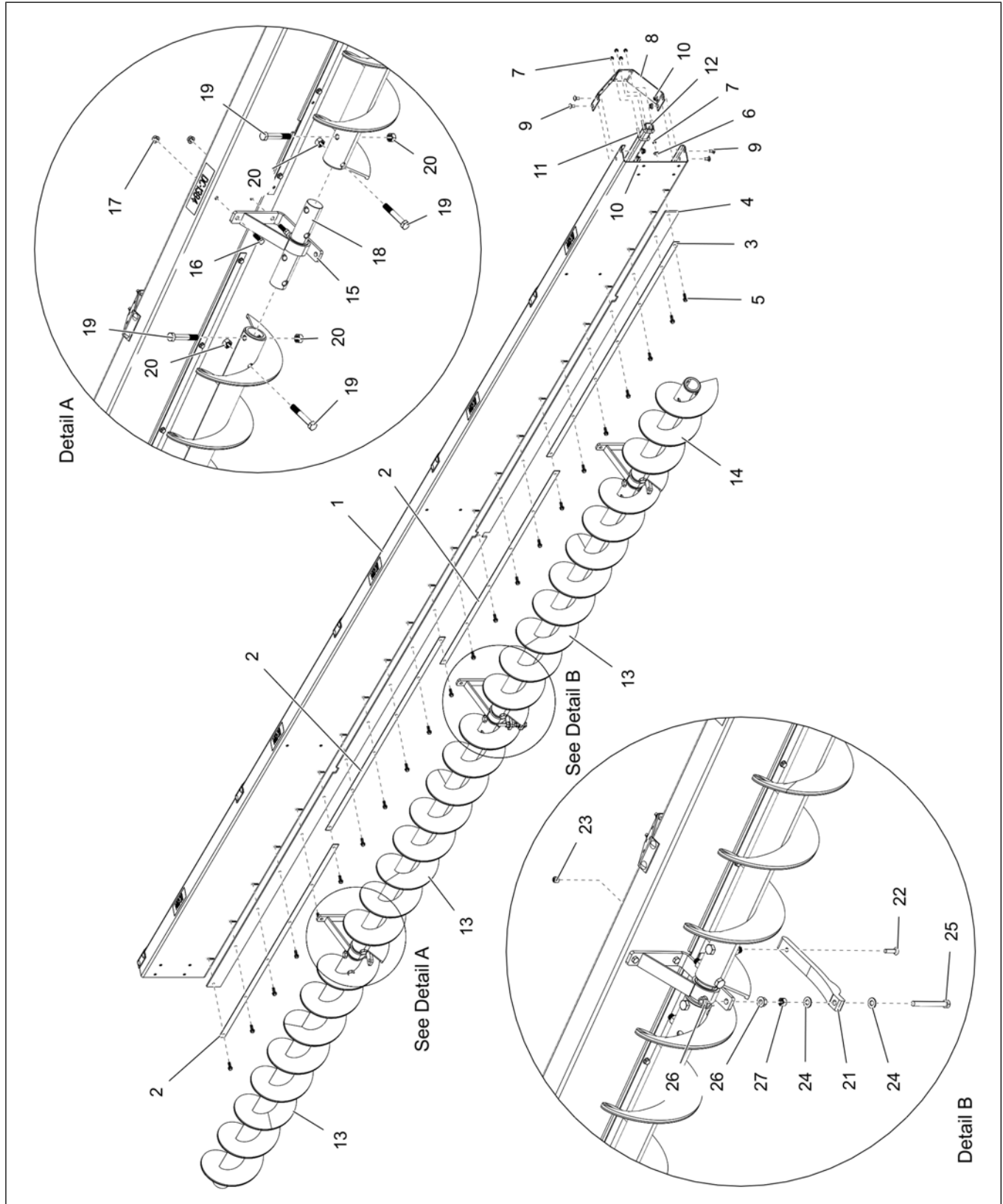

Table 7-28 Backshield with four augers for short sweep (48 ft) – Parts list

Ref #	Part #	Description
1	GK80854	Backshield – 10 in. x 48 ft bin – short
2	GK80534	Wiper retainer standard – 30 ft to 72 ft bins
3	GK80860	Wiper retainer – 48 ft bin – short
4	GK80849	Backshield wiper – 48 ft bin – short
5	S-7470	5/16 x 1 in. flange bolt
6	S-845	5/16 in. flat washer
7	S-7382	5/16 in. nylock nut
8	GK80715	Torque tube bracket
9	S-7391	3/8 x 3/4 in. carriage bolt
10	S-968	3/8 in. flange nut
11	S-10521	U-bolt
12	GK80875	Torque tube – 48 ft bin – short
13	GK80727	9 in. x 6 ft. 1.50 in. 1/4 in. flight weldment standard
14	GK80826	9 in. x 2 ft. 4.75 in. 1/4 in. flight weldment – 48 ft bin – short
15	GK80711	Hanger bracket assembly – 10 in. HD
16	S-3886	7/16 x 1-1/4 in. HHCS bolt
17	S-9073	7/16 in. flange nut
18	GK2222	2 in. OD x 11.5 in. connecting shaft
19	S-7893	5/8 x 4 in. HHCS bolt
20	S-8606	5/8 in. stover nut
21	GK80725	Support skid
22	S-8255	3/8 x 1-1/2 in. screw
23	S-7383	3/8 in. nylock nut
24	S-2120	1/2 in. flat washer SAE
25	2FH1038	1/2 x 4-1/2 in. HHTB bolt
26	S-8506	1/2 in. flange nut
27	S-8315	1/2 in. stover nut

Figure 7-23 Backshield with four augers for short sweep (54 ft) – Exploded view

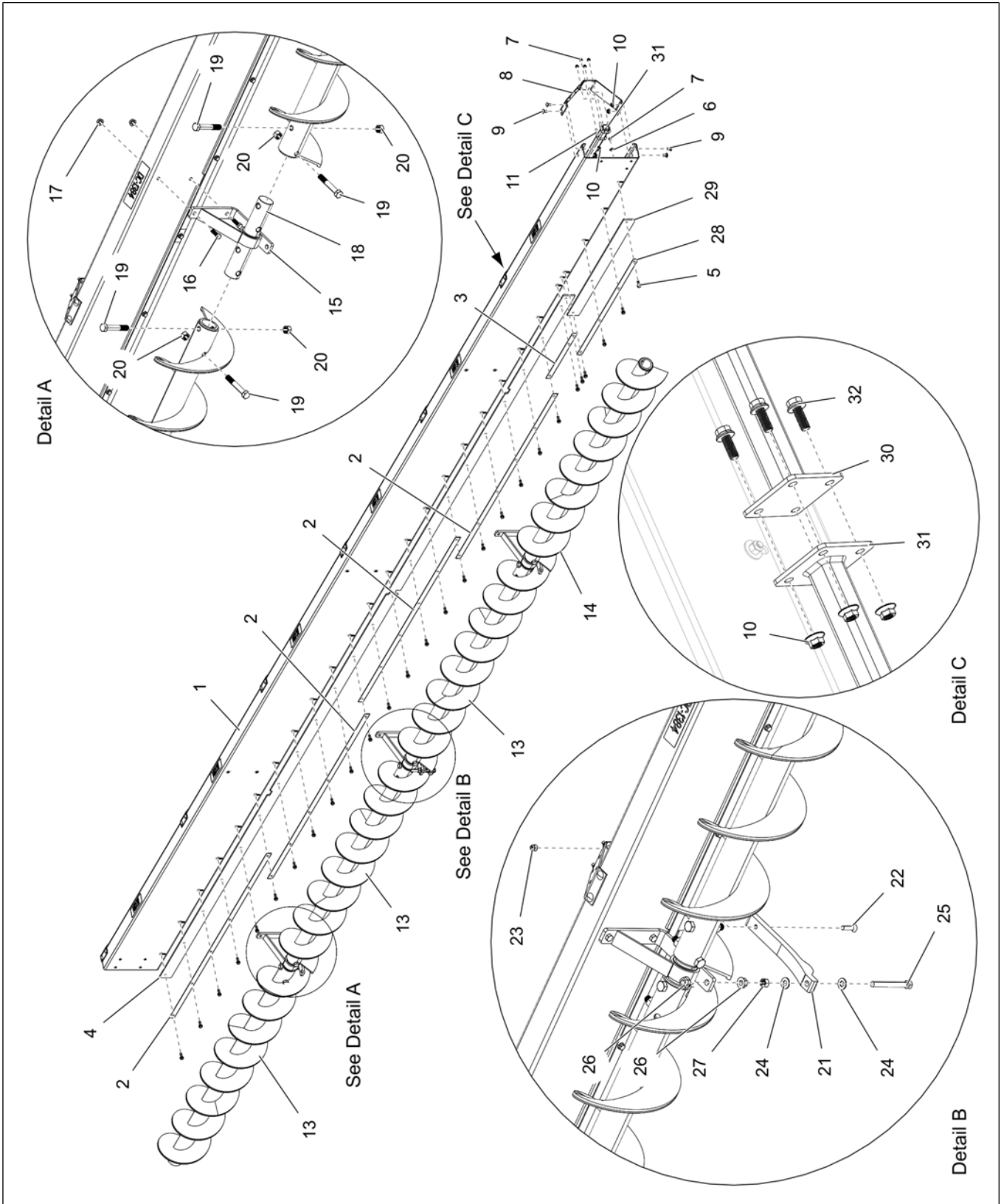

Table 7-29 Backshield with four augers for short sweep (54 ft) – Parts list

Ref #	Part #	Description
1	GK80855	Backshield – 10 in. x 54 ft bin – short
2	GK80534	Wiper retainer standard – 30 ft to 72 ft bins
3	GK80493	Wiper retainer – 48 ft bin
4	GK80504	Backshield wiper – 48 ft bin
5	S-7470	5/16 x 1 in. flange bolt
6	S-845	5/16 in. flat washer
7	S-7382	5/16 in. nylock nut
8	GK80715	Torque tube bracket
9	S-7391	3/8 x 3/4 in. carriage bolt
10	S-968	3/8 in. flange nut
11	S-10521	U-bolt
13	GK80727	9 in. x 6 ft. 1.50 in. 1/4 in. flight weldment standard
14	GK80827	9 in. x 5 ft. 4.75 in. 1/4 in. flight weldment – 54 ft bin – short
15	GK80711	Hanger bracket assembly – 10 in. HD
16	S-3886	7/16 x 1-1/4 in. HHCS bolt
17	S-9073	7/16 in. flange nut
18	GK2222	2 in. OD x 11.5 in. connecting shaft
19	S-7893	5/8 x 4 in. HHCS bolt
20	S-8606	5/8 in. stover nut
21	GK80725	Support skid
22	S-8255	3/8 x 1-1/2 in. screw
23	S-7383	3/8 in. nylock nut
24	S-2120	1/2 in. flat washer SAE
25	2FH1038	1/2 x 4-1/2 in. HHTB bolt
26	S-8506	1/2 in. flange nut
27	S-8315	1/2 in. stover nut
28	GK80861	Wiper retainer extension – 54 ft bin – short
29	GK80844	Wiper extension – 54 ft bin – short
30	GK80768	Torque tube weldment standard – 54 ft bin
31	GK80880	Torque tube weldment – 54 ft bin – short
32	S-9065	3/8 x 1 in. flange bolt

Backshield with Five Augers for Standard Sweeps (60 Ft and 66 Ft Bins)

Figure 7-24 Backshield with five augers (60 ft) – Exploded view

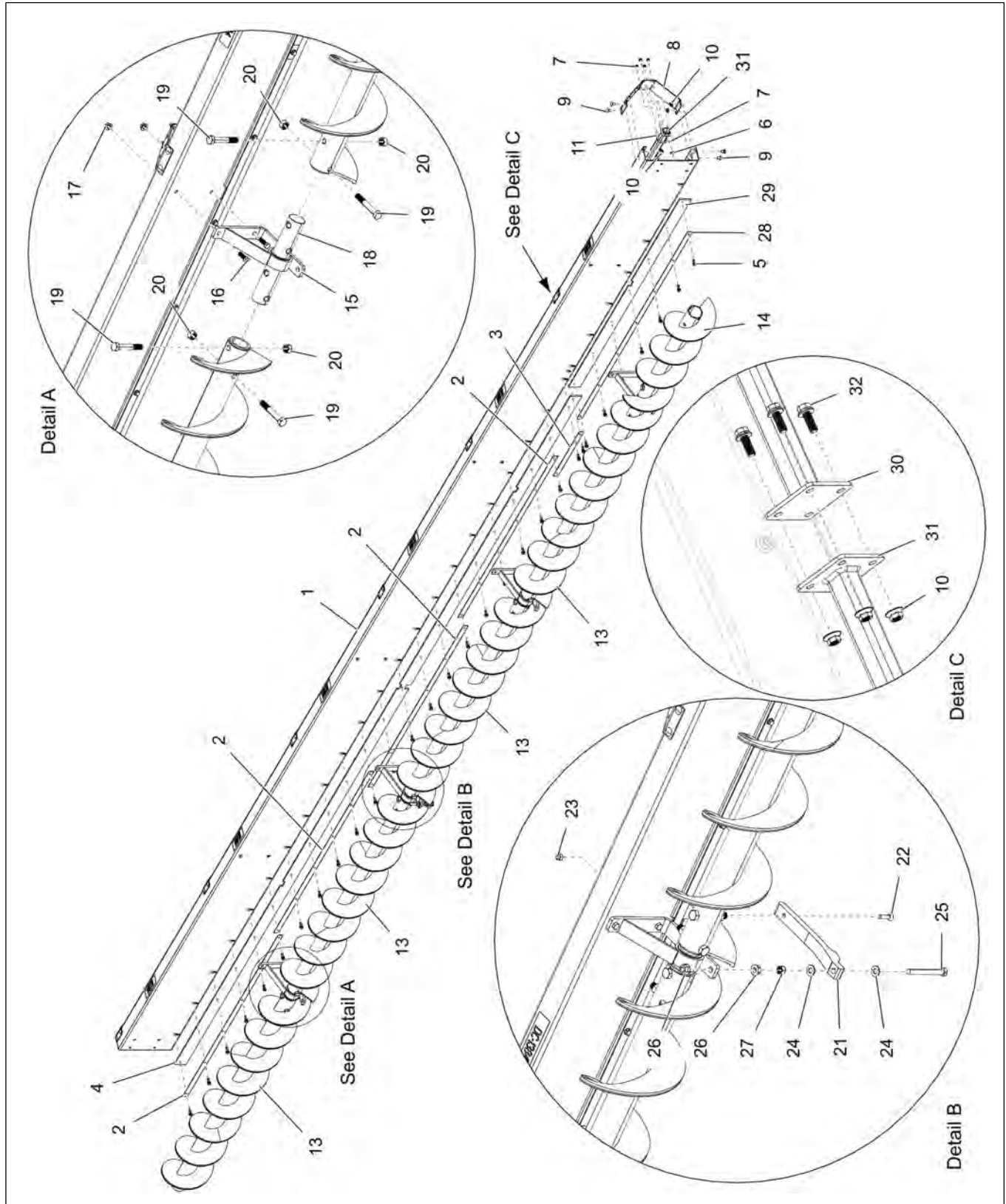

Table 7-30 Backshield with five augers (60 ft) – Parts list

Ref #	Part #	Description
1	GK80699	Backshield – 10 in. x 60 ft bin
2	GK80534	Wiper retainer standard – 30 ft to 72 ft bins
3	GK80493	Wiper retainer – 48 ft bin
4	GK80504	Backshield wiper – 48 ft bin
5	S-7470	5/16 x 1 in. flange bolt
6	S-845	5/16 in. flat washer
7	S-7382	5/16 in. nylock nut
8	GK80715	Torque tube bracket
9	S-7391	3/8 x 3/4 in. carriage bolt
10	S-968	3/8 in. flange nut
11	S-10521	U-bolt
13	GK80727	9 in. x 6 ft. 1.50 in. 1/4 in. flight weldment standard
14	GK80799	9 in. x 2 ft. 9 in. 1/4 in. flight weldment – 60 ft bin
15	GK80711	Hanger bracket assembly – 10 in. HD
16	S-3886	7/16 x 1-1/4 in. HHCS bolt
17	S-9073	7/16 in. flange nut
18	GK2222	2 in. OD x 11.5 in. connecting shaft
19	S-7893	5/8 x 4 in. HHCS bolt
20	S-8606	5/8 in. stover nut
21	GK80725	Support skid
22	S-8255	3/8 x 1-1/2 in. screw
23	S-7383	3/8 in. nylock nut
24	S-2120	1/2 in. flat washer SAE
25	2FH1038	1/2 x 4-1/2 in. HHTB bolt
26	S-8506	1/2 in. flange nut
27	S-8315	1/2 in. stover nut
28	GK80782	Wiper retainer extension – 60 ft bin
29	GK80773	Wiper extension – 60 ft bin
30	GK80778	Torque tube weldment standard – 60 ft bin
31	GK80779	Torque tube weldment – 60 ft bin
32	S-9065	3/8 x 1 in. flange bolt

Figure 7-25 Backshield with five augers (66 ft) – Exploded view

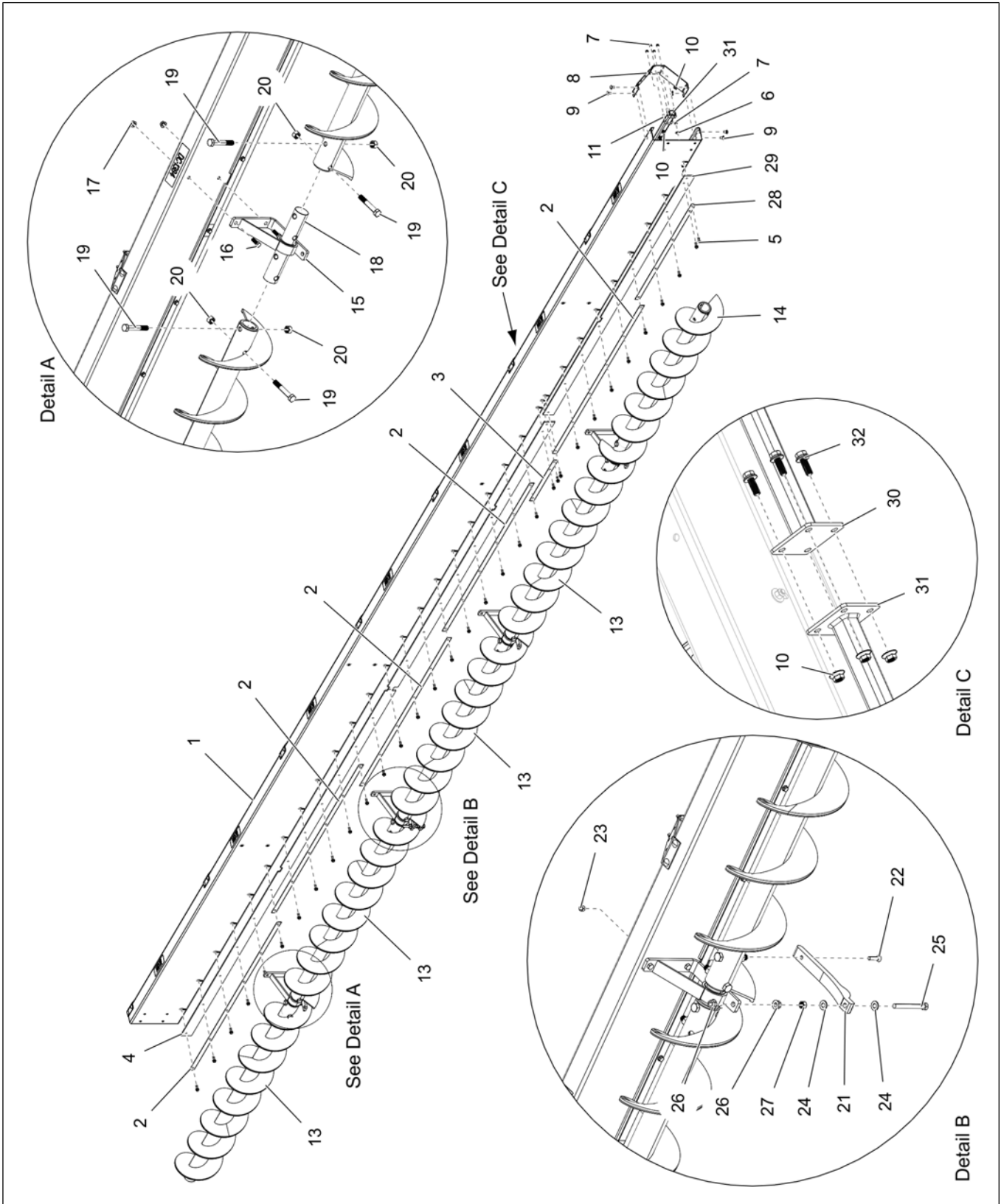

Table 7-31 Backshield with five augers (66 ft) – Parts list

Ref #	Part #	Description
1	GK80700	Backshield – 10 in. x 66 ft bin
2	GK80534	Wiper retainer standard – 30 ft to 72 ft bins
3	GK80493	Wiper retainer – 48 ft bin
4	GK80504	Backshield wiper – 48 ft bin
5	S-7470	5/16 x 1 in. flange bolt
6	S-845	5/16 in. flat washer
7	S-7382	5/16 in. nylock nut
8	GK80715	Torque tube bracket
9	S-7391	3/8 x 3/4 in. carriage bolt
10	S-968	3/8 in. flange nut
11	S-10521	U-bolt
13	GK80727	9 in. x 6 ft. 1.50 in. 1/4 in. flight weldment standard
14	GK80800	9 in. x 5 ft. 9 in. 1/4 in. flight weldment – 66 ft bin
15	GK80711	Hanger bracket assembly – 10 in. HD
16	S-3886	7/16 x 1-1/4 in. HHCS bolt
17	S-9073	7/16 in. flange nut
18	GK2222	2 in. OD x 11.5 in. connecting shaft
19	S-7893	5/8 x 4 in. HHCS bolt
20	S-8606	5/8 in. stover nut
21	GK80725	Support skid
22	S-8255	3/8 x 1-1/2 in. screw
23	S-7383	3/8 in. nylock nut
24	S-2120	1/2 in. flat washer SAE
25	2FH1038	1/2 x 4-1/2 in. HHTB bolt
26	S-8506	1/2 in. flange nut
27	S-8315	1/2 in. stover nut
28	GK80786	Wiper retainer extension – 66 ft bin
29	GK80774	Wiper extension – 66 ft bin
30	GK80778	Torque tube weldment standard – 60 ft bin
31	GK80788	Torque tube weldment – 66 ft bin
32	S-9065	3/8 x 1 in. flange bolt

Backshield with Five Augers for Short Sweeps (60 Ft and 66 Ft Bins)

Figure 7-26 Backshield with five augers for short sweep (60 ft) – Exploded view

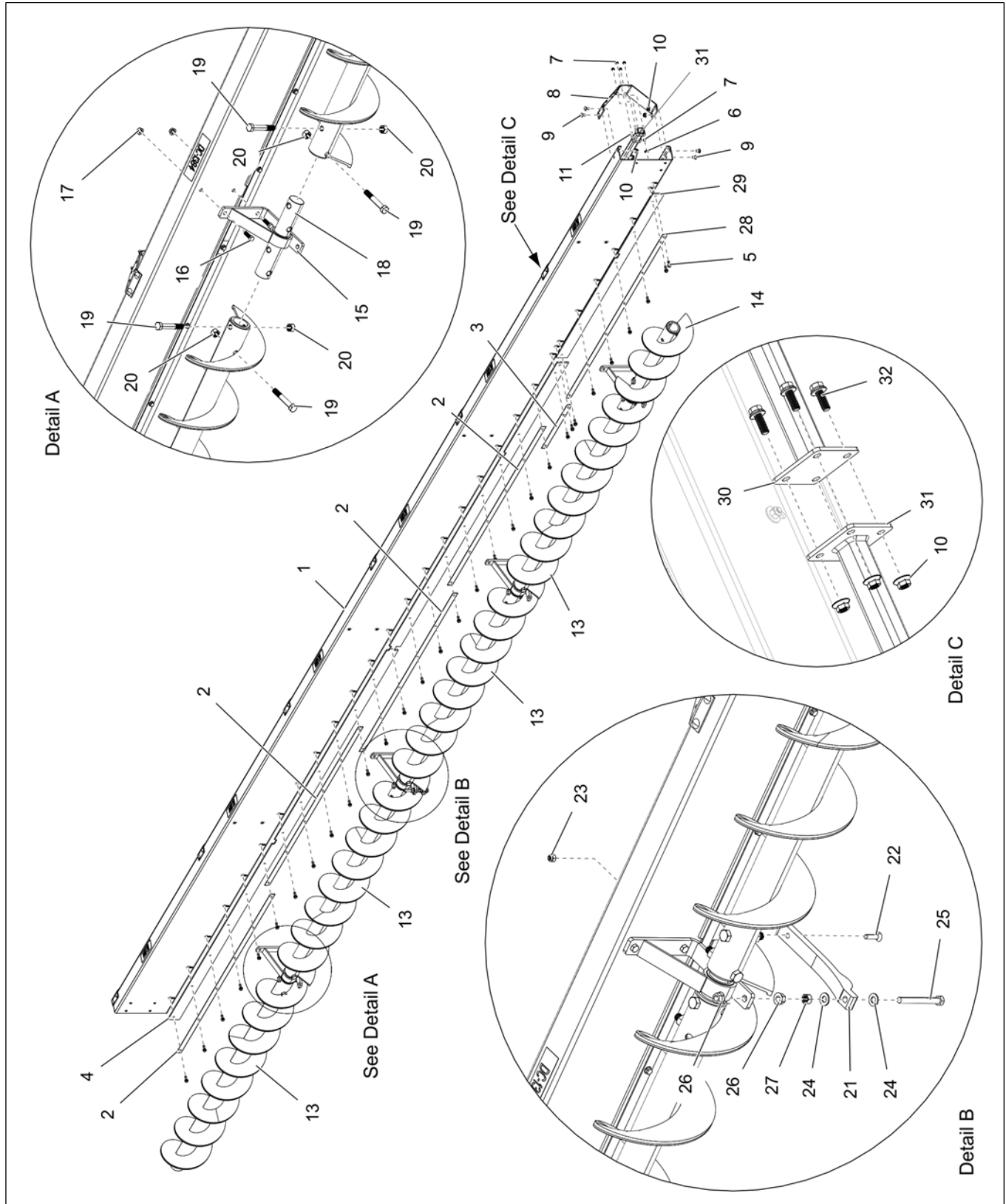

Table 7-32 Backshield with five augers for short sweep (60 ft) – Parts list

Ref #	Part #	Description
1	GK80856	Backshield – 10 in. x 60 ft bin – short
2	GK80534	Wiper retainer standard – 30 ft to 72 ft bins
3	GK80493	Wiper retainer – 48 ft bin
4	GK80504	Backshield wiper – 48 ft bin
5	S-7470	5/16 x 1 in. flange bolt
6	S-845	5/16 in. flat washer
7	S-7382	5/16 in. nylock nut
8	GK80715	Torque tube bracket
9	S-7391	3/8 x 3/4 in. carriage bolt
10	S-968	3/8 in. flange nut
11	S-10521	U-bolt
13	GK80727	9 in. x 6 ft. 1.50 in. 1/4 in. flight weldment standard
14	GK80828	9 in. x 2 ft. 1 in. 1/4 in. flight weldment – 60 ft bin – short
15	GK80711	Hanger bracket assembly – 10 in. HD
16	S-3886	7/16 x 1-1/4 in. HHCS bolt
17	S-9073	7/16 in. flange nut
18	GK2222	2 in. OD x 11.5 in. connecting shaft
19	S-7893	5/8 x 4 in. HHCS bolt
20	S-8606	5/8 in. stover nut
21	GK80725	Support skid
22	S-8255	3/8 x 1-1/2 in. screw
23	S-7383	3/8 in. nylock nut
24	S-2120	1/2 in. flat washer SAE
25	2FH1038	1/2 x 4-1/2 in. HHTB bolt
26	S-8506	1/2 in. flange nut
27	S-8315	1/2 in. stover nut
28	GK80862	Wiper retainer extension – 60 ft bin – short
29	GK80845	Wiper extension – 60 ft bin – short
30	GK80778	Torque tube weldment standard – 60 ft bin
31	GK80881	Torque tube weldment – 60 ft bin – short
32	S-9065	3/8 x 1 in. flange bolt

Figure 7-27 Backshield with five augers for short sweep (66 ft) – Exploded view

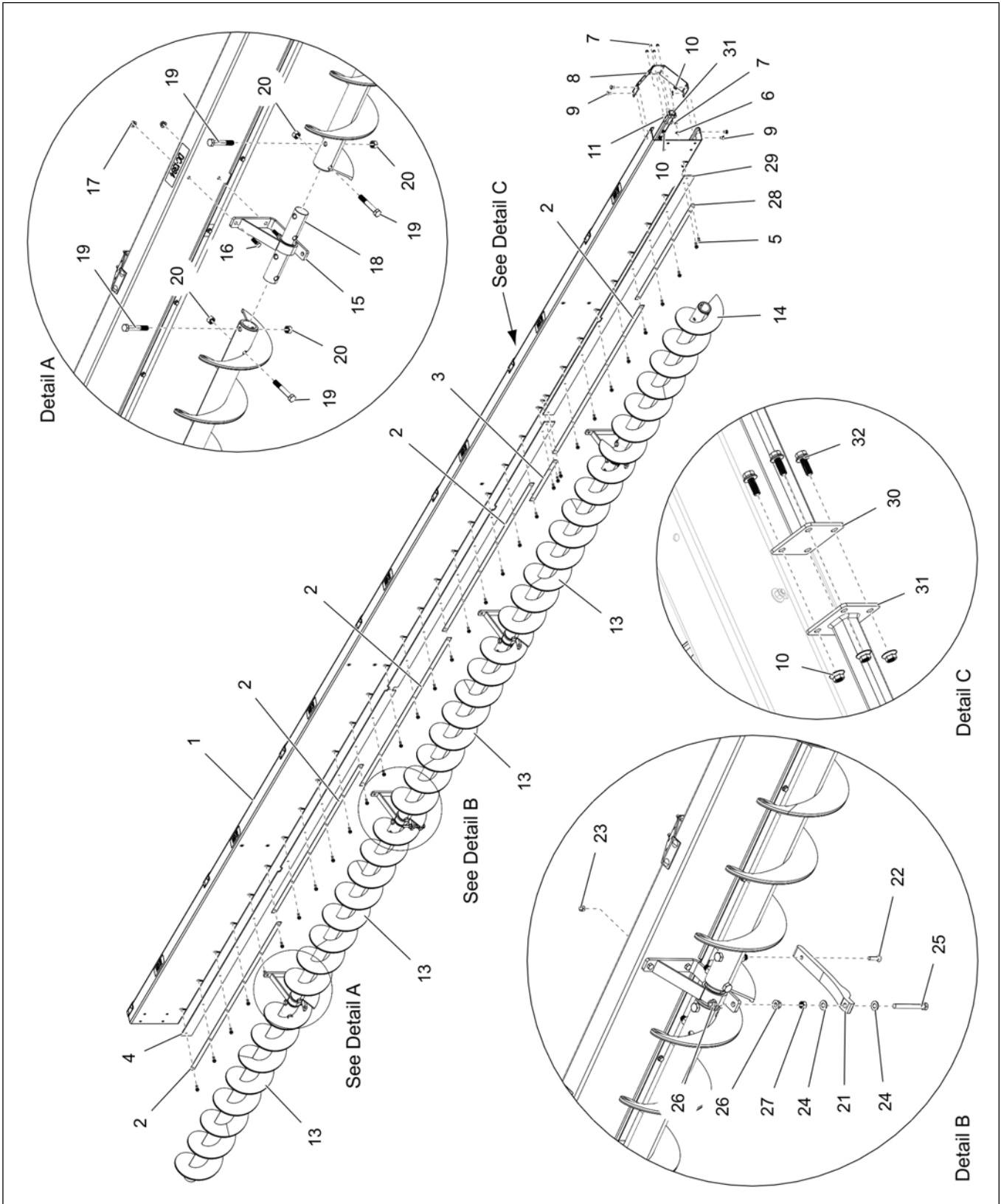

Table 7-33 Backshield with five augers for short sweep (66 ft) – Parts list

Ref #	Part #	Description
1	GK80857	Backshield – 10 in. x 66 ft bin – short
2	GK80534	Wiper retainer standard – 30 ft to 72 ft bins
3	GK80493	Wiper retainer – 48 ft bin
4	GK80504	Backshield wiper – 48 ft bin
5	S-7470	5/16 x 1 in. flange bolt
6	S-845	5/16 in. flat washer
7	S-7382	5/16 in. nylock nut
8	GK80715	Torque tube bracket
9	S-7391	3/8 x 3/4 in. carriage bolt
10	S-968	3/8 in. flange nut
11	S-10521	U-bolt
13	GK80727	9 in. x 6 ft. 1.50 in. 1/4 in. flight weldment standard
14	GK80829	9 in. x 5 ft. 1 in. 1/4 in. flight weldment – 66 ft bin – short
15	GK80711	Hanger bracket assembly – 10 in. HD
16	S-3886	7/16 x 1-1/4 in. HHCS bolt
17	S-9073	7/16 in. flange nut
18	GK2222	2 in. OD x 11.5 in. connecting shaft
19	S-7893	5/8 x 4 in. HHCS bolt
20	S-8606	5/8 in. stover nut
21	GK80725	Support skid
22	S-8255	3/8 x 1-1/2 in. screw
23	S-7383	3/8 in. nylock nut
24	S-2120	1/2 in. flat washer SAE
25	2FH1038	1/2 x 4-1/2 in. HHTB bolt
26	S-8506	1/2 in. flange nut
27	S-8315	1/2 in. stover nut
28	GK80863	Wiper retainer extension – 66 ft bin – short
29	GK80846	Wiper extension – 66 ft bin – short
30	GK80778	Torque tube weldment standard – 60 ft bin
31	GK80882	Torque tube weldment – 66 ft bin – short
32	S-9065	3/8 x 1 in. flange bolt

Backshield with Six Augers for Standard Sweeps (72 Ft Bins)

Figure 7-28 Backshield with six augers – Exploded view

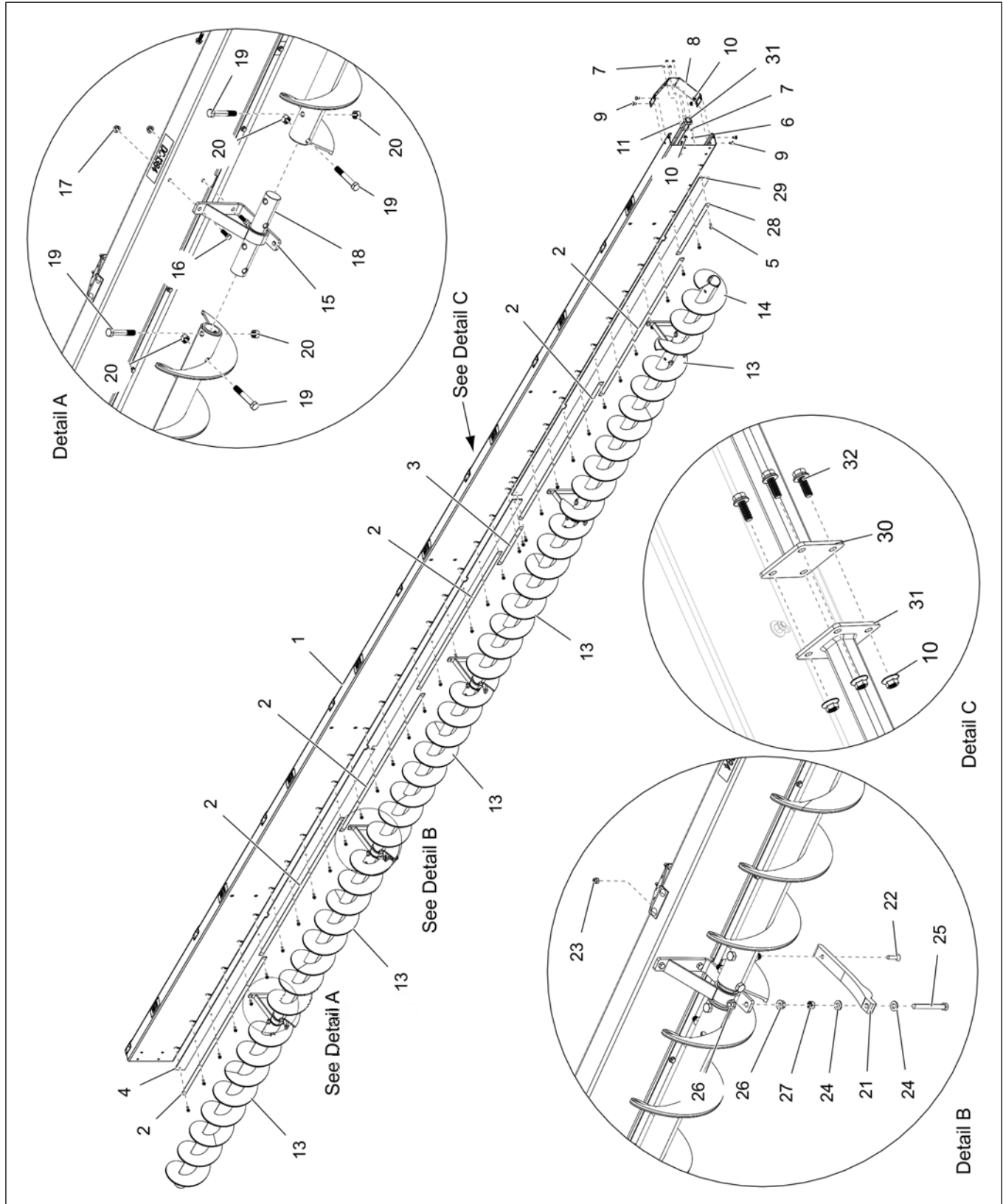

Table 7-34 Backshield with six augers – Parts list

Ref #	Part #	Description
1	GK80701	Backshield – 10 in. x 72 ft bin
2	GK80534	Wiper retainer standard – 30 ft to 72 ft bins
3	GK80493	Wiper retainer – 48 ft bin
4	GK80504	Backshield wiper – 48 ft bin
5	S-7470	5/16 x 1 in. flange bolt
6	S-845	5/16 in. flat washer
7	S-7382	5/16 in. nylock nut
8	GK80715	Torque tube bracket
9	S-7391	3/8 x 3/4 in. carriage bolt
10	S-968	3/8 in. flange nut
11	S-10521	U-bolt
13	GK80727	9 in. x 6 ft. 1.50 in. 1/4 in. flight weldment standard
14	GK80801	9 in. x 2 ft. 4.50 in. 1/4 in. flight weldment – 72 ft bin
15	GK80711	Hanger bracket assembly – 10 in. HD
16	S-3886	7/16 x 1-1/4 in. HHCS bolt
17	S-9073	7/16 in. flange nut
18	GK2222	2 in. OD x 11.5 in. connecting shaft
19	S-7893	5/8 x 4 in. HHCS bolt
20	S-8606	5/8 in. stover nut
21	GK80725	Support skid
22	S-8255	3/8 x 1-1/2 in. screw
23	S-7383	3/8 in. nylock nut
24	S-2120	1/2 in. flat washer SAE
25	2FH1038	1/2 x 4-1/2 in. HHTB bolt
26	S-8506	1/2 in. flange nut
27	S-8315	1/2 in. stover nut
28	GK80786	Wiper retainer extension – 30 ft bin – short
29	GK80775	Wiper extension – 72 ft bin
30	GK80768	Torque tube weldment standard – 54 ft bin
31	GK80795	Torque tube weldment – 72 ft bin
32	S-9065	3/8 x 1 in. flange bolt

Backshield with Six Augers for Short Sweeps (72 Ft Bins)

Figure 7-29 Backshield with six augers for short sweep – Exploded view

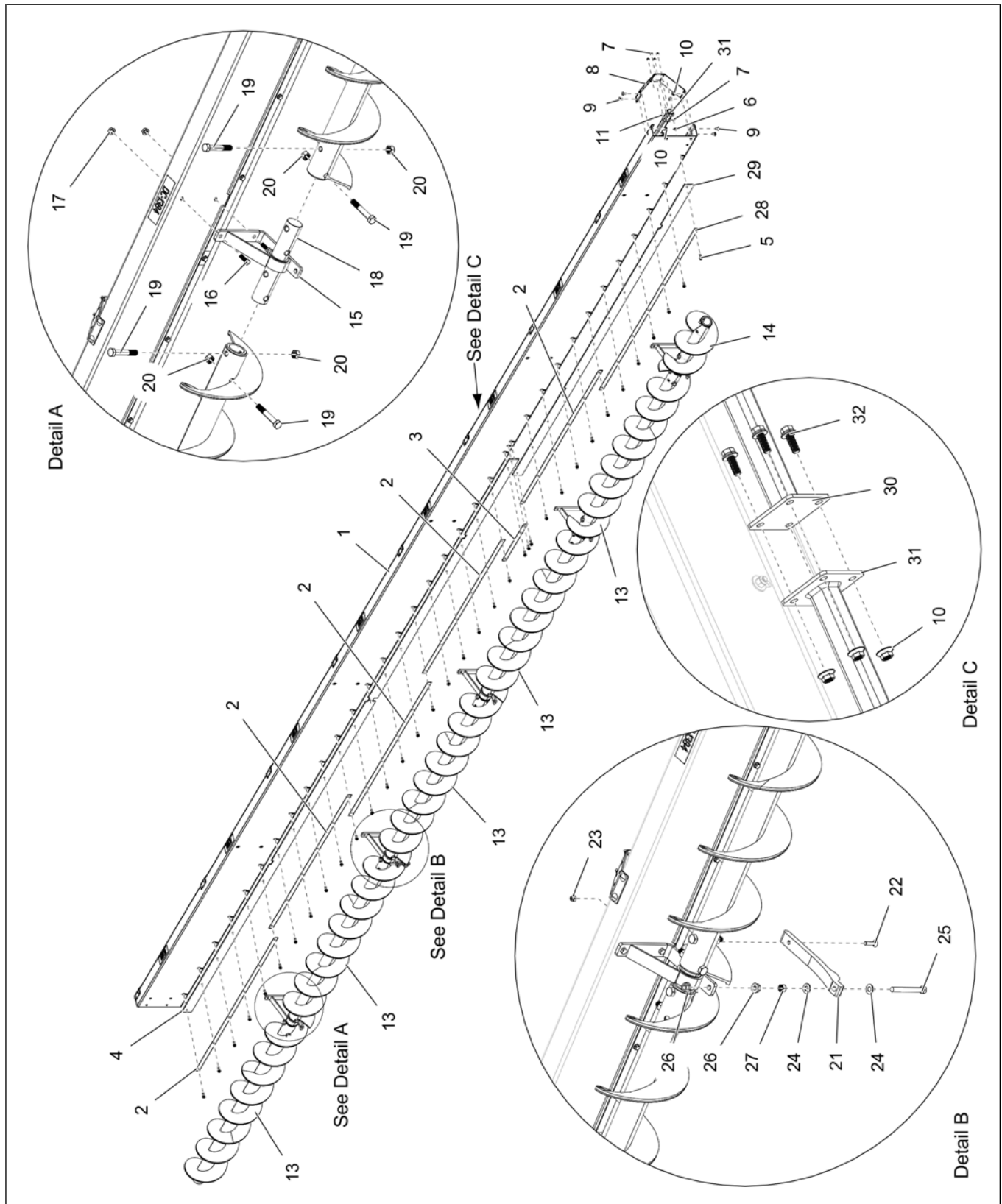

Table 7-35 Backshield with six augers for short sweep – Parts list

Ref #	Part #	Description
1	GK80858	Backshield – 10 in. x 72 ft bin – short
2	GK80534	Wiper retainer standard – 30 ft to 72 ft bins
3	GK80493	Wiper retainer – 48 ft bin
4	GK80504	Backshield wiper – 48 ft bin
5	S-7470	5/16 x 1 in. flange bolt
6	S-845	5/16 in. flat washer
7	S-7382	5/16 in. nylock nut
8	GK80715	Torque tube bracket
9	S-7391	3/8 x 3/4 in. carriage bolt
10	S-968	3/8 in. flange nut
11	S-10521	U-bolt
13	GK80727	9 in. x 6 ft. 1.50 in. 1/4 in. flight weldment standard
14	GK80830	9 in. x 1 ft. 8.25 in. 1/4 in. flight weldment – 72 ft bin – short
15	GK80711	Hanger bracket assembly – 10 in. HD
16	S-3886	7/16 x 1-1/4 in. HHCS bolt
17	S-9073	7/16 in. flange nut
18	GK2222	2 in. OD x 11.5 in. connecting shaft
19	S-7893	5/8 x 4 in. HHCS bolt
20	S-8606	5/8 in. stover nut
21	GK80725	Support skid
22	S-8255	3/8 x 1-1/2 in. screw
23	S-7383	3/8 in. nylock nut
24	S-2120	1/2 in. flat washer SAE
25	2FH1038	1/2 x 4-1/2 in. HHTB bolt
26	S-8506	1/2 in. flange nut
27	S-8315	1/2 in. stover nut
28	GK80864	Wiper retainer extension – 72 ft bin – short
29	GK80847	Wiper extension – 72 ft bin – short
30	GK80768	Torque tube weldment standard – 54 ft bin
31	GK80883	Torque tube weldment – 72 ft bin – short
32	S-9065	3/8 x 1 in. flange bolt

Backshield Connections

Figure 7-30 Backshield connections – Exploded view

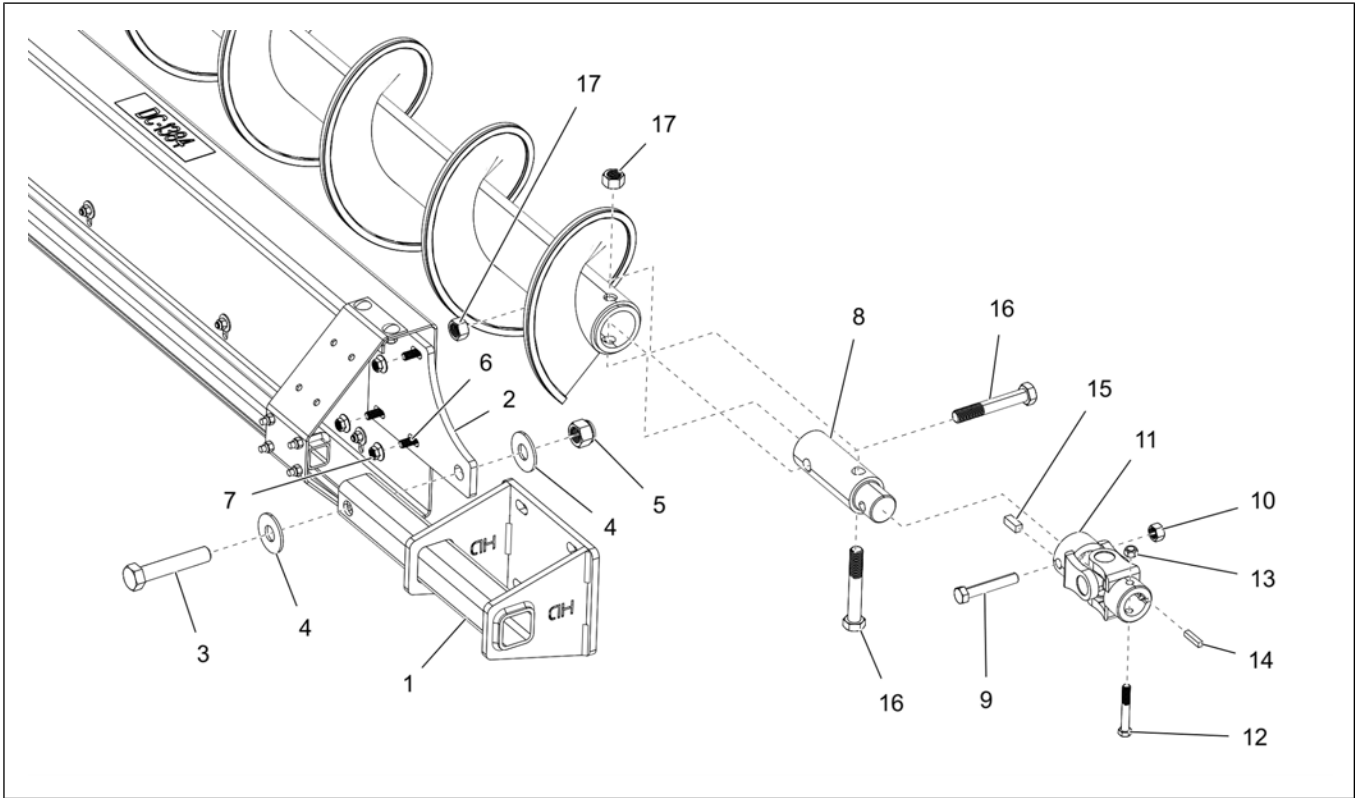

Table 7-36 Backshield connections – Parts list

Ref #	Part #	Description
1	GK80713-Y	Gearbox mount assembly – 10 in. HD
2	GK80608-Y	Backshield pivot bracket – 8 in.
3	S-7884	3/4 x 4 in. HHCS bolt
4	S-866	3/4 in. flat washer
5	S-7217	3/4 in. nylock nut
6	S-9066	3/8 in. flange bolt
7	S-968	3/8 in. flange nut
8	GK80726	2 in. x 6.5 in. U-joint connecting shaft
9	S-8252	1/2 x 3 in. HHCS bolt
10	S-8315	1/2 in. stover nut
11	GK7614	U-joint 1.25 in. B and 1.5 in. B x 5.50 in. long 12E
12	S-10107	3/8 in. HHCS bolt
13	S-8251	3/8 in. stover nut
14	S-8382	1/4 x 1/4 x 1-1/4 in. square key
15	GC03540	3/8 x 3/8 x 1 in. key
16	S-7893	5/8 x 4 in. HHCS bolt
17	S-8606	5/8 in. stover nut

GSI Group, LLC Limited Warranty

The GSI Group, LLC (“GSI”) warrants products which it manufactures to be free of defects in materials and workmanship under normal usage and conditions for a period of 12 months after sale to the original end-user or if a foreign sale, 14 months from arrival at port of discharge, whichever is earlier. The end-user’s sole remedy (and GSI’s only obligation) is to repair or replace, at GSI’s option and expense, products that in GSI’s judgment, contain a material defect in materials or workmanship. Expenses incurred by or on behalf of the end-user without prior written authorization from the GSI Warranty Group shall be the sole responsibility of the end-user.

Warranty Extensions: The Limited Warranty period is extended for the following products:

	Product	Warranty Period
AP Fans and Flooring	Performer Series Direct Drive Fan Motor	3 Years
	All Fiberglass Housings	Lifetime
	All Fiberglass Propellers	Lifetime
AP/Cumberland	Flex-Flo/Pan Feeding System Motors	2 Years
Cumberland Feeding/Watering Systems	Feeder System Pan Assemblies	5 Years **
	Feed Tubes (1-3/4" and 2.00")	10 Years *
	Centerless Augers	10 Years *
	Watering Nipples	10 Years *
Grain Systems	Grain Bin Structural Design	5 Years
Grain Systems Farm Fans Zimmerman	Portable and Tower Dryers	2 Years
	Portable and Tower Dryer Frames and Internal Infrastructure †	5 Years

* Warranty prorated from list price:
 0 to 3 years - no cost to end-user
 3 to 5 years - end-user pays 25%
 5 to 7 years - end-user pays 50%
 7 to 10 years - end-user pays 75%

** Warranty prorated from list price:
 0 to 3 years - no cost to end-user
 3 to 5 years - end-user pays 50%

† Motors, burner components and moving parts not included.
 Portable dryer screens included.
 Tower dryer screens not included.

GSI further warrants that the portable and tower dryer frame and basket, excluding all auger and auger drive components, shall be free from defects in materials for a period of time beginning on the twelfth (12th) month from the date of purchase and continuing until the sixtieth (60th) month from the date of purchase (extended warranty period). During the extended warranty period, GSI will replace the frame or basket components that prove to be defective under normal conditions of use without charge, excluding the labor, transportation, and/or shipping costs incurred in the performance of this extended warranty.

Conditions and Limitations:

THERE ARE NO WARRANTIES THAT EXTEND BEYOND THE LIMITED WARRANTY DESCRIPTION SET FORTH ABOVE. SPECIFICALLY, GSI MAKES NO FURTHER WARRANTY OF ANY KIND, EXPRESS OR IMPLIED, INCLUDING, WITHOUT LIMITATION, WARRANTIES OF MERCHANTABILITY OR FITNESS FOR A PARTICULAR PURPOSE OR USE IN CONNECTION WITH: (I) PRODUCT MANUFACTURED OR SOLD BY GSI OR (II) ANY ADVICE, INSTRUCTION, RECOMMENDATION OR SUGGESTION PROVIDED BY AN AGENT, REPRESENTATIVE OR EMPLOYEE OF GSI REGARDING OR RELATED TO THE CONFIGURATION, INSTALLATION, LAYOUT, SUITABILITY FOR A PARTICULAR PURPOSE, OR DESIGN OF SUCH PRODUCTS.

GSI shall not be liable for any direct, indirect, incidental or consequential damages, including, without limitation, loss of anticipated profits or benefits. The sole and exclusive remedy is set forth in the Limited Warranty, which shall not exceed the amount paid for the product purchased. This warranty is not transferable and applies only to the original end-user. GSI shall have no obligation or responsibility for any representations or warranties made by or on behalf of any dealer, agent or distributor.

GSI assumes no responsibility for claims resulting from construction defects or unauthorized modifications to products which it manufactured. Modifications to products not specifically delineated in the manual accompanying the equipment at initial sale will void the Limited Warranty.

This Limited Warranty shall not extend to products or parts which have been damaged by negligent use, misuse, alteration, accident or which have been improperly/inadequately maintained. This Limited Warranty extends solely to products manufactured by GSI.

Prior to installation, the end-user has the responsibility to comply with federal, state and local codes which apply to the location and installation of products manufactured or sold by GSI.

9101239_1_CR_rev8.xml (revised January 2014)

This equipment shall be installed in accordance with the current installation codes and applicable regulations which should be carefully followed in all cases. Authorities having jurisdiction should be consulted before installations are made.



1004 E. Illinois St.
Assumption, IL 62510-0020
Phone: 1-217-226-4421
Fax: 1-217-226-4420
www.gsiag.com



GSI is a worldwide brand of AGCO Corporation.