

# Series II Sweep Retrofit Kit Instructions

Instruction Manual

**PNEG-2155**

**Version 1.0**

**Date: 06-30-17**



PNEG-2155

---

**All information, illustrations, photos, and specifications in this manual are based on the latest information available at the time of publication. The right is reserved to make changes at any time without notice.**

---

# Contents

<b>Chapter 1</b>	<b>Safety Cautions</b> .....	<b>5</b>
	Safety Guidelines .....	5
	Cautionary Symbol Definitions.....	6
	Safety Precautions .....	7
	Safety Sign-off Sheet.....	12
<b>Chapter 2</b>	<b>Motor Frame Swap Instructions</b> .....	<b>13</b>
<b>Chapter 3</b>	<b>Parts List</b> .....	<b>23</b>
	Series II Sweep Retrofit Kit Parts List.....	24
	<b>GSI Group, LLC Limited Warranty</b> .....	<b>27</b>

---

# NOTES

# 1 Safety Cautions

## Topics Covered in this Chapter

- Safety Guidelines
- Cautionary Symbol Definitions
- Safety Precautions
- Safety Sign-off Sheet

## Safety Guidelines

Safety guidelines are general-to-specific safety rules that must be followed at all times. This manual is written to help you understand safe operating procedures and problems that can be encountered by the operator and other personnel when using this equipment. Save these safety guidelines for future reference.

As owner or operator, you are responsible for understanding the requirements, hazards, and precautions that exist and to inform others as required. Unqualified persons must stay out of the work area at all times.

Alterations must not be made to the equipment. Alterations can produce dangerous situations resulting in **SERIOUS INJURY** or **DEATH**.

This equipment must be installed in accordance with the current installation codes and applicable regulations, which must be carefully followed in all cases. Authorities having jurisdiction must be consulted before installations are made.

When necessary, you must consider the installation location relative to electrical, fuel and water utilities.







Personnel operating or working around equipment must read this manual. This manual must be delivered with equipment to its owner. Failure to read this manual and its safety instructions is a misuse of the equipment.

ST-0001-3

## Cautionary Symbol Definitions

Cautionary symbols appear in this manual and on product decals. The symbols alert the user of potential safety hazards, prohibited activities and mandatory actions. To help you recognize this information, we use the symbols that are defined below.

**Table 1-1** Description of the different cautionary symbols

Symbol	Description
	This symbol indicates an imminently hazardous situation which, if not avoided, <b>will result in serious injury or death.</b>
	This symbol indicates a potentially hazardous situation which, if not avoided, <b>can result in serious injury or death.</b>
	This symbol indicates a potentially hazardous situation which, if not avoided, <b>can result in minor or moderate injury.</b>
	This symbol is used to address practices not related to personal injury.
	This symbol indicates a general hazard.
	This symbol indicates a prohibited activity.
	This symbol indicates a mandatory action.

ST-0005-2

## Safety Precautions

This is all the topics contained in the Master Safety Reference File. Mainly used to verify formatting before releasing the topic.

### Use Personal Protective Equipment

- Use appropriate personal protective equipment:

**Eye Protection**



**Respiratory Protection**



**Foot Protection**



**Hearing Protection**



**Head Protection**



**Fall Protection**



**Hand Protection**



- Wear clothing appropriate to the job.
- Remove all jewelry.
- Tie long hair up and back.

ST-0004-1

## Chapter 1: Safety Cautions

### Follow Safety Instructions

- Carefully read all safety messages in this manual and safety signs on your machine. Keep signs in good condition. Replace missing or damaged safety signs. Be sure new equipment components and repair parts include the current safety signs. Replacement safety signs are available from the manufacturer.
- Learn how to operate the machine and how to use controls properly. Do not let anyone operate without instruction.
- If you do not understand any part of this manual or need assistance, contact your dealer.



ST-0002-1

### Lifting Hazard

- Single person lift can cause injury.
- Use a mechanical lifting device to lift or move the equipment during installation.



ST-0021-2

### Maintain Equipment and Work Area

- Understand service procedures before doing work. Keep area clean and dry.
- Never service equipment while it is operating. Keep hands, feet, and clothing away from moving parts.
- Keep your equipment in proper working condition. Replace worn or broken parts immediately.



ST-0003-1

### Sharp Edge Hazard

- This product has sharp edges, which can cause serious injury.
- To avoid injury, handle sharp edges with caution and always use proper protective clothing and equipment.



ST-0036-2



## Rotating Auger Hazard

- Keep clear of rotating augers and moving parts.
- Do not remove or modify guards or covers.
- Lock-out power source before making adjustments, cleaning, or maintaining equipment.
- Failure to follow these precautions will result in serious injury or death.



ST-0037-1

## Stay Clear of Moving Parts

- Entanglement in rotating sprocket or moving chain will cause serious injury or death.
- Keep all guards and covers in place at all times.
- Lock-out power source before making adjustments, cleaning, or maintaining equipment.



ST-0063-1

## Operate Motor Properly

- All electrical connections must be made in accordance with applicable local codes (National Electrical Code for the US, Canadian Electric Code, or EN60204 along with applicable European Directives for Europe). Make sure equipment and bins are properly grounded.
- Lock-out power before resetting motor overloads.
- Do not repetitively stop and start the drive in order to free a plugged condition. Jogging the drive in this manner can damage the equipment and drive components.

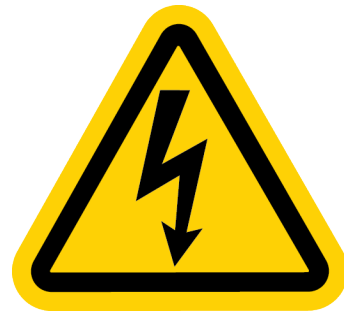

ST-0009-3

### Do Not Enter Bin

- Rotating flighting will kill or dismember.
- Flowing material will trap and suffocate.
- Crusted material will collapse and suffocate.
  - If you must enter the bin:
    1. Shut off and lock out all power sources.
    2. Use a safety harness and safety line.
    3. Station another person outside the bin.
    4. Avoid the center of the bin.
    5. Wear proper breathing equipment or respirator.



ST-0061-1

**Use Unload Equipment Properly**

- Do not operate this equipment alone. Make sure someone nearby is aware of the proper shut down sequence in the event of an emergency.
- Do not allow any person intoxicated or under the influence of drugs to operate this equipment. All operators must be adequately rested and prepared to perform all functions of operating the equipment.
- Do not start equipment until all persons are clear of the work area and safety guards are in place.
- Do not allow anyone inside a bin, truck, or wagon which is being unloaded by an auger. Flowing grain can trap and suffocate in seconds.
- Use ample overhead lighting after sunset to light the work area.
- Always use caution to not hit the auger when positioning the load.
- Do not leave equipment operating while unattended.
- Be aware of pinch points, which can trap or catch objects and cause injury.
- Be sure all equipment is locked in position before operating.
- Always lock out all power sources to the equipment when unloading is finished.



ST-0051-1



# 2 Motor Frame Swap Instructions

## What You Should Know

This retrofit kit is used for fixing the problem that occurs with Series II Sweeps. This kit will replace the auger motor frame with a heavier motor frame similar to the existing X-Series Sweep.

1. Disconnect the electrical power and unbolt the conduit from the first section of sweep frame.
2. Remove the existing belt guards (1, 4, 5 and 6), belts (3), pulleys (2 and 19), motor mount (11) and motor (10) from the center pivot assembly.

**Figure 2-1** Removing the belt guards, belts, motor and pulley

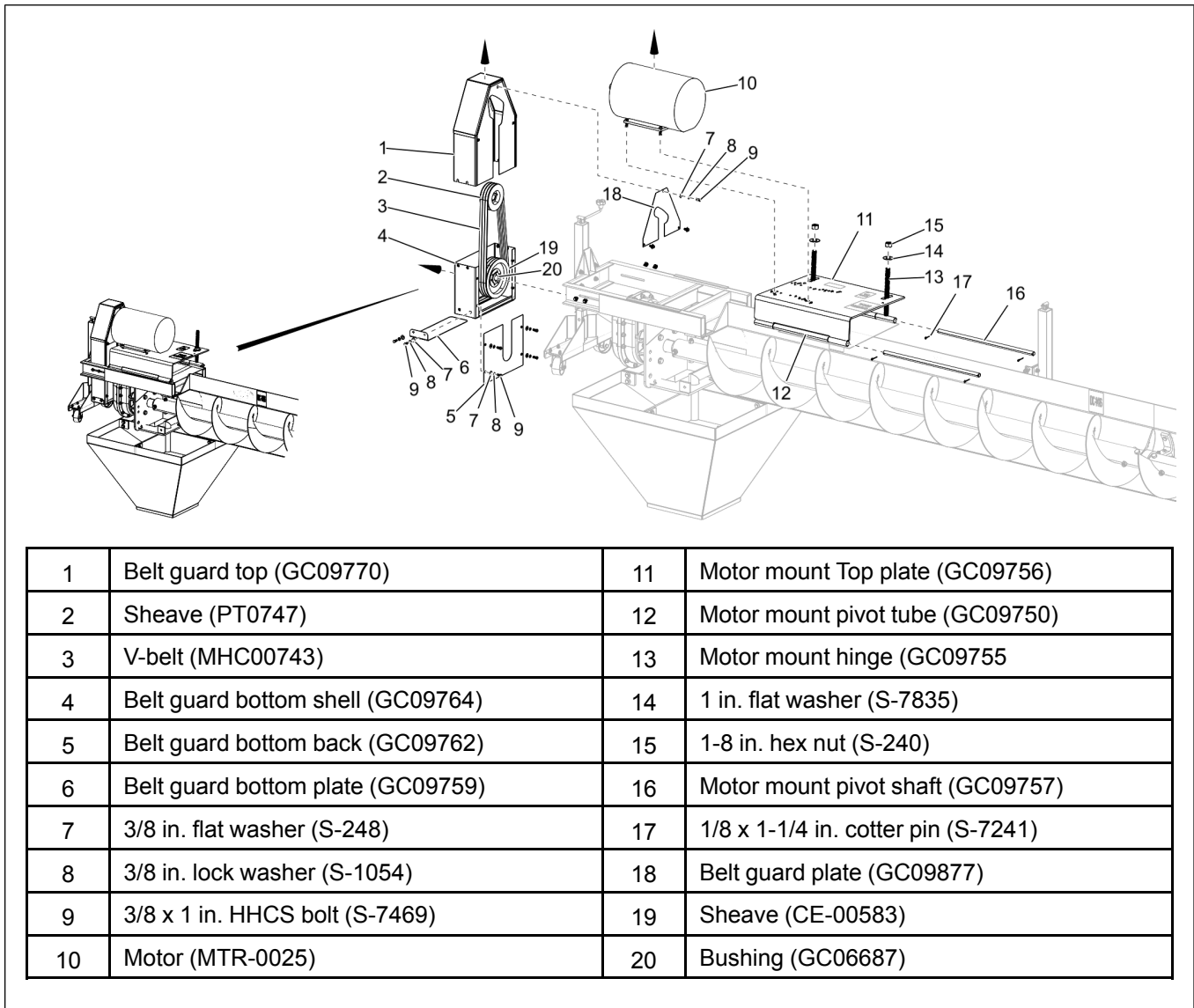

## Chapter 2: Motor Frame Swap Instructions

- Remove the existing motor frame (22) along with motor jack assembly (21) from the center pivot assembly.

**Figure 2-2** Removing the motor frame

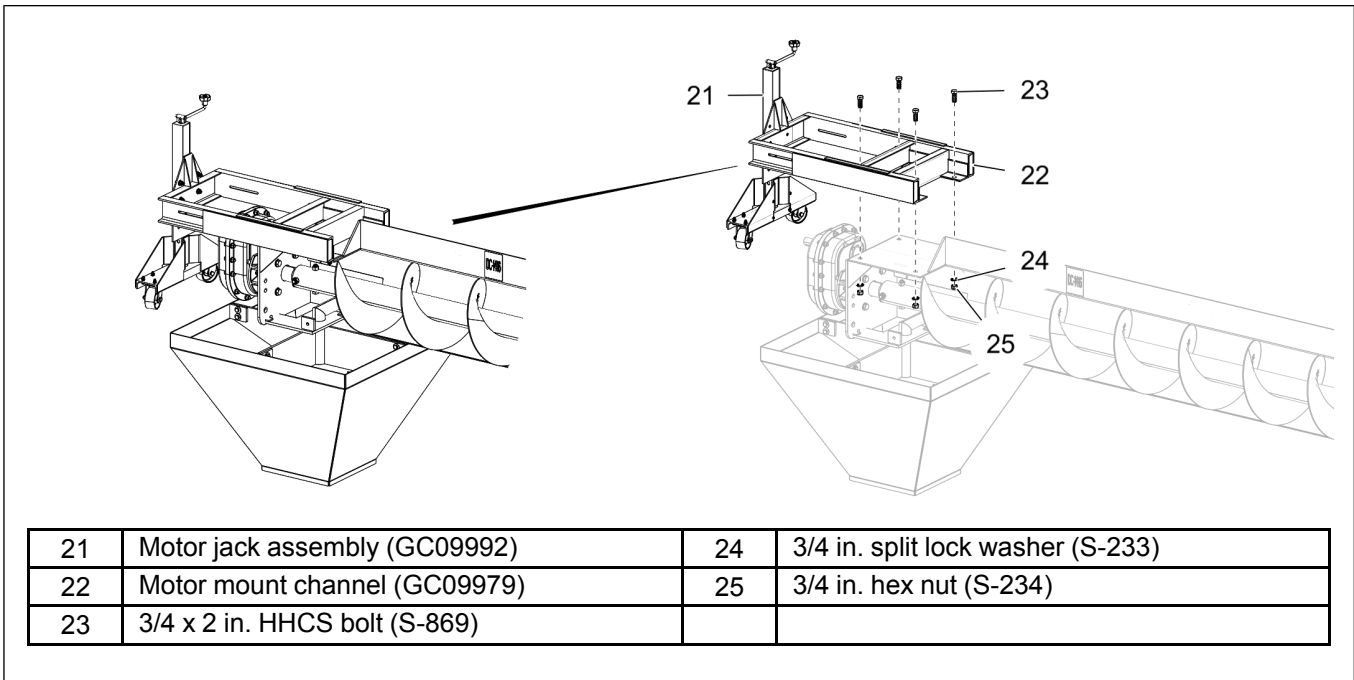

- Move the reducer and sweep section (26) along with the auger away from the center well (29) to access the existing spider assembly (27).

**Figure 2-3** Separating the center well

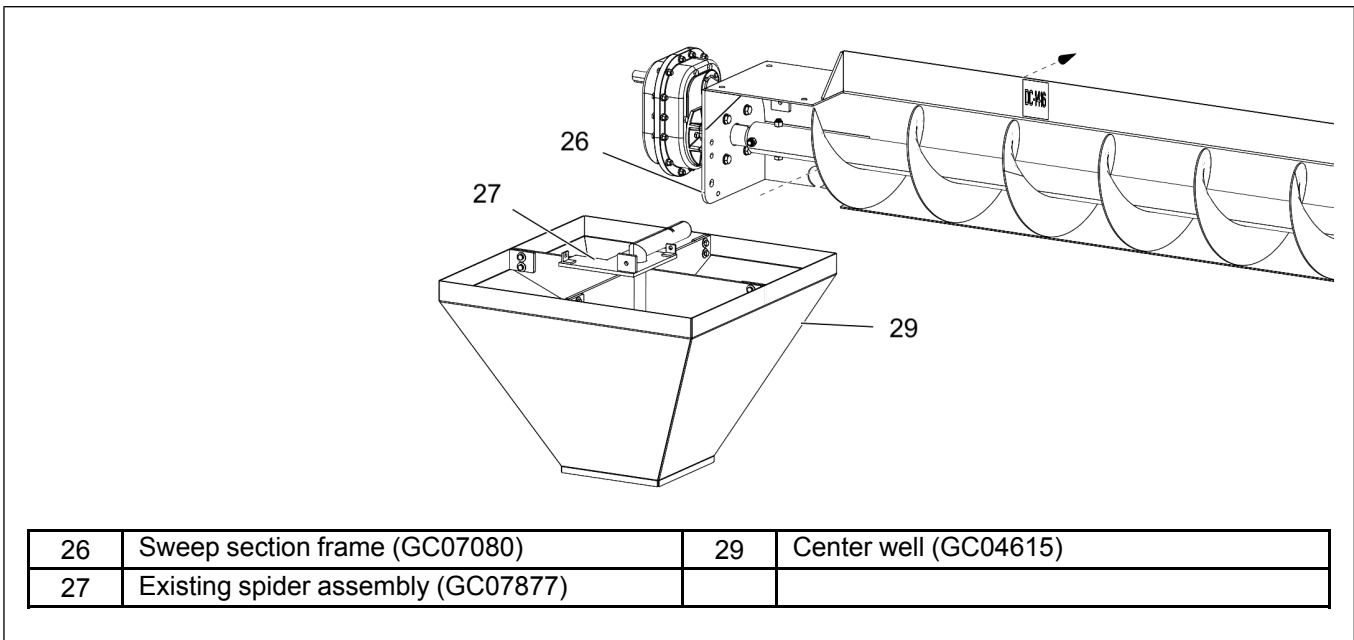

5. Remove the existing spider assembly (27) from the center well (29) and replace with new spider assembly (28).

**Figure 2-4** Replacing the spider assembly

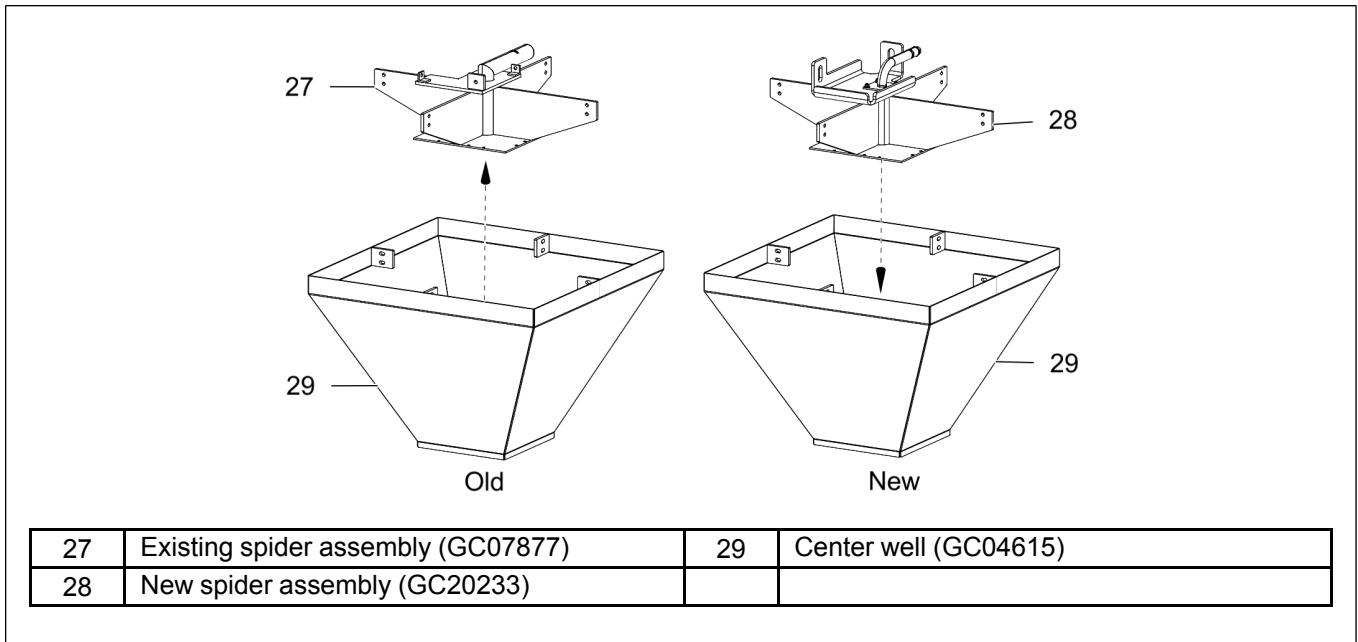

6. Using the template (52), cut out 3 holes (54) into the rear plate of existing sweep center section (26).
7. Using the template (53), cut out 3 holes and a slot (55) into the side plate of existing sweep center section (26).

**Figure 2-5** Plasma cutting holes and slot

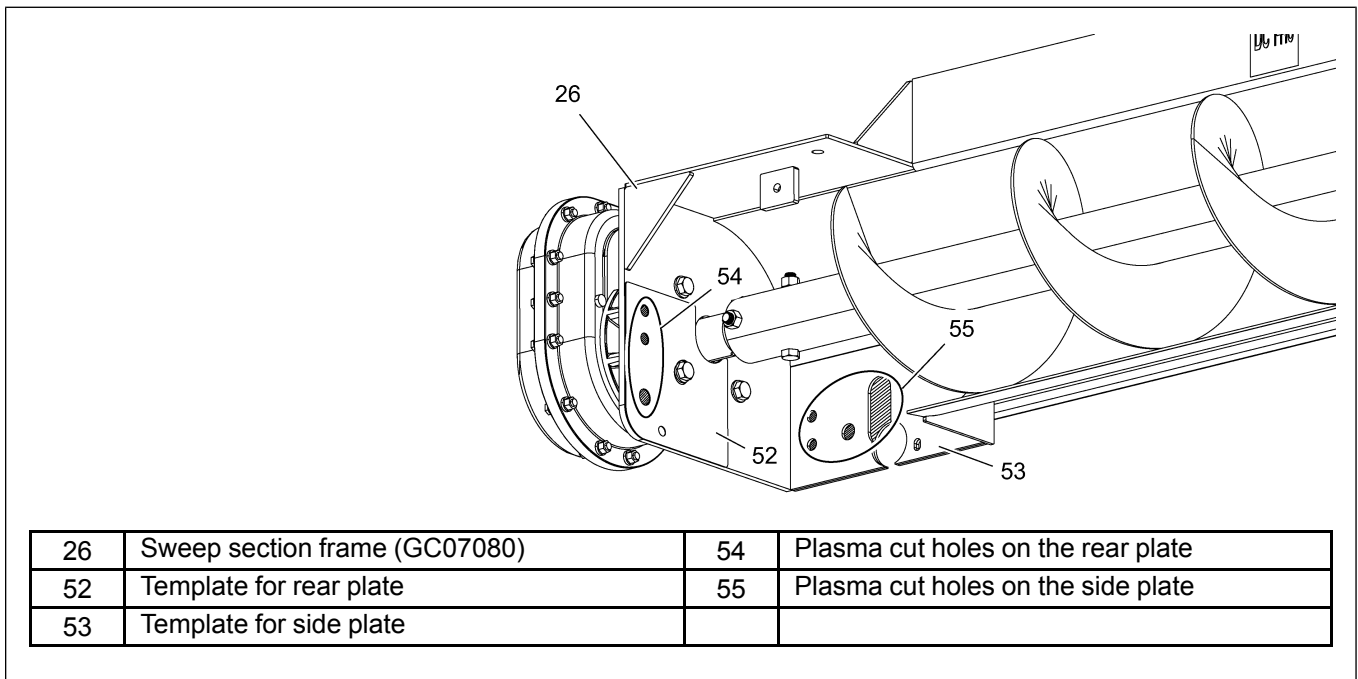

## Chapter 2: Motor Frame Swap Instructions

8. Move the reducer and sweep section (26) back along with the auger and attach it to the spider assembly (28) using the provided bolts (30 and 31), washers (14 and 24) and nuts (25 and 32).

**NOTE:** The new sweep section connection is floating type, when compared to the previous connection.

**Figure 2-6** Attaching the sweep section to the spider assembly

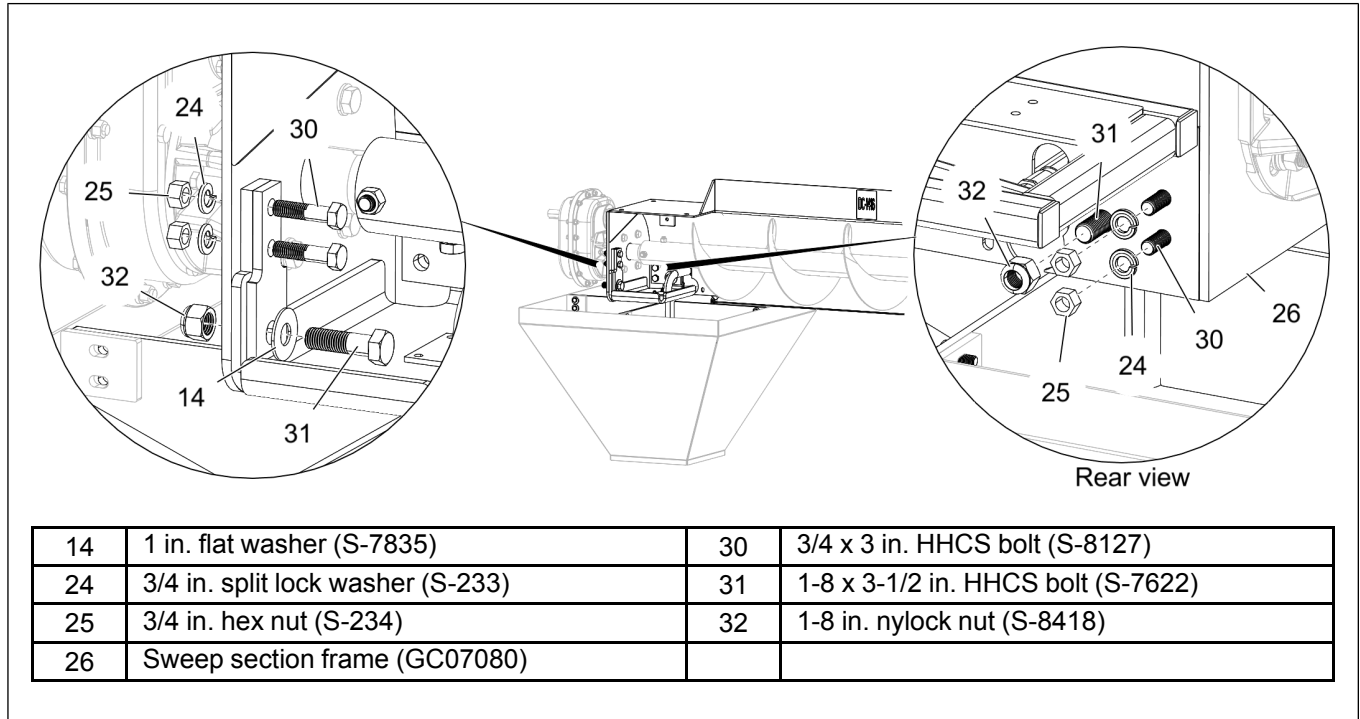

9. Install skids (34) and caster mounts (46) to motor frame (33) using bolts (35), washers (36) and nuts (37).

**Figure 2-7** Installing the skids and caster mount to the motor frame

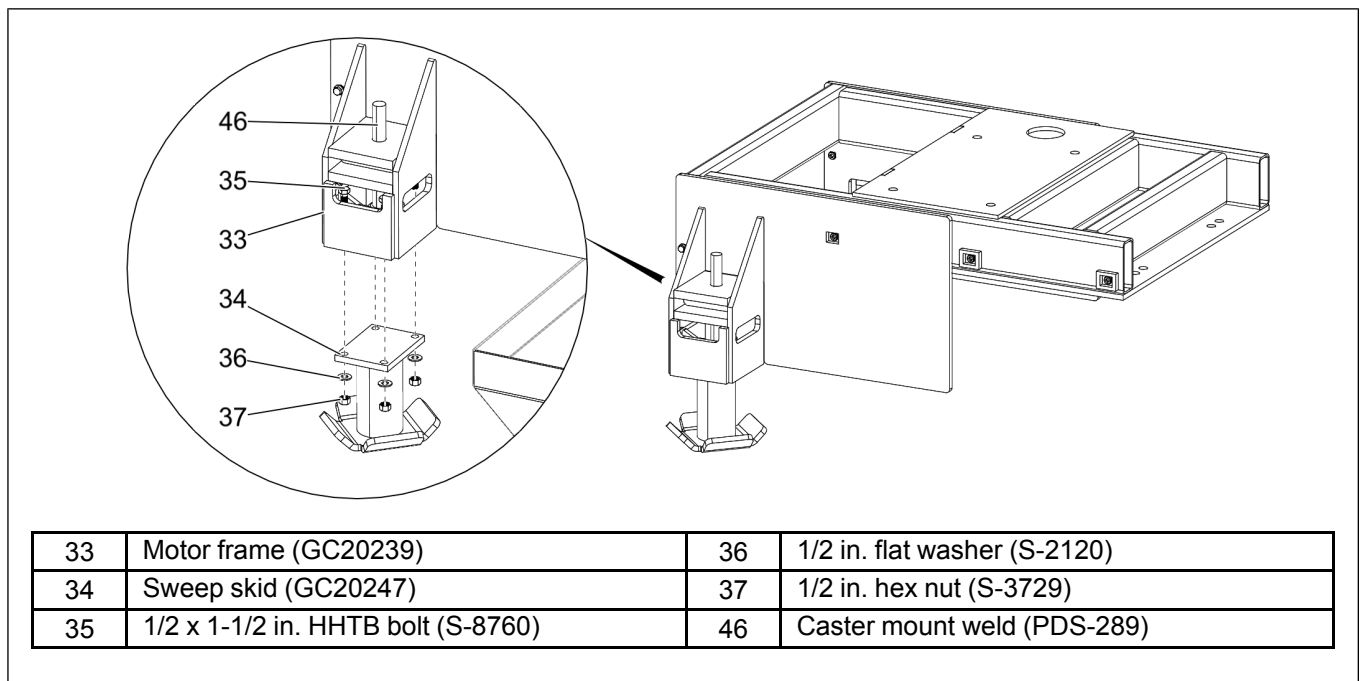



10. Install new motor frame assembly (33) to the center pivot using the bolts (23), washers (24) and nuts (25).

**Figure 2-8** *Installing the new motor frame to the sweep center section*

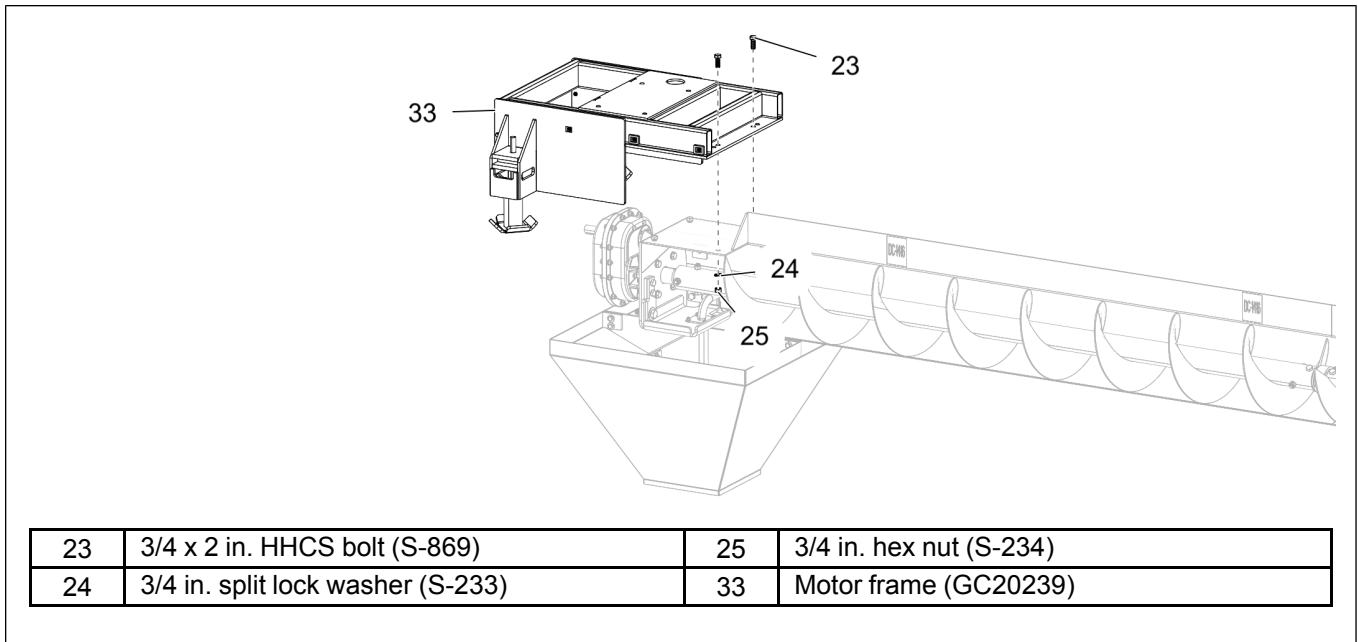

11. Install the motor mount plate (38) to the motor frame (33) using the thread rod (39), washers (40) and nuts (25).

**Figure 2-9** *Installing the motor mount plate to the motor frame*

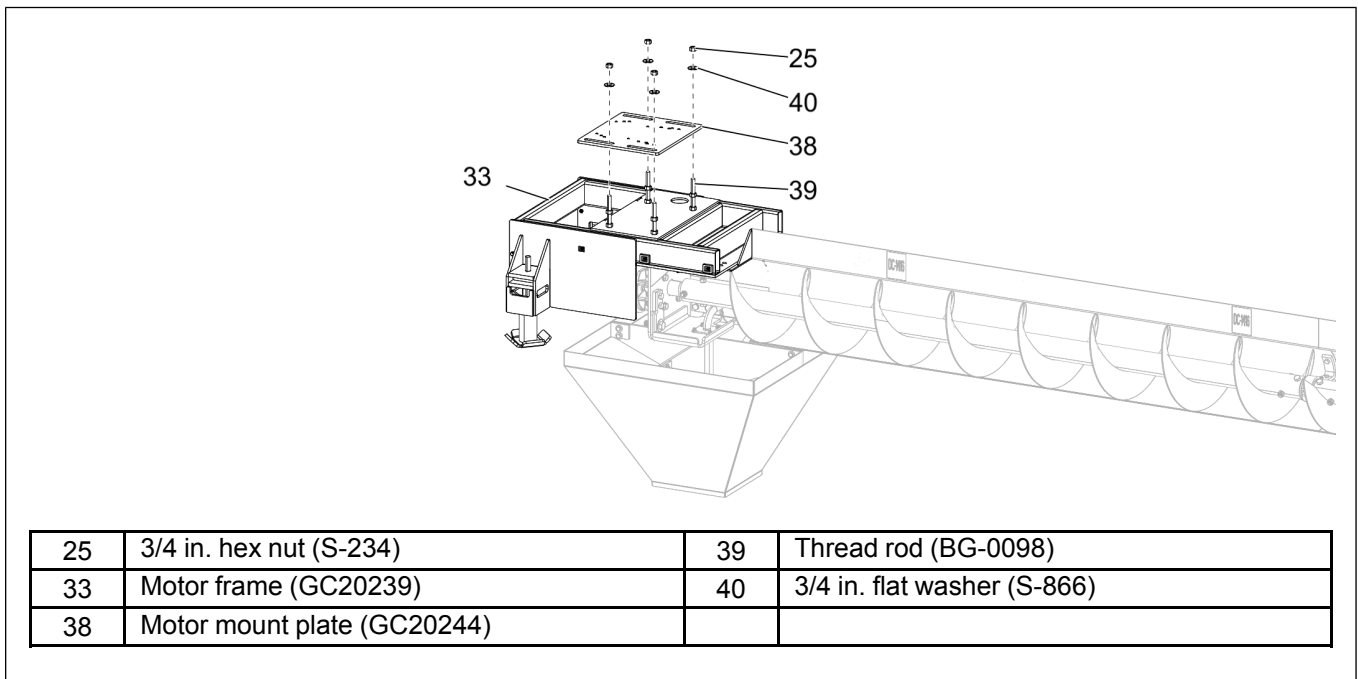

## Chapter 2: Motor Frame Swap Instructions

12. Install the pulley (2), belts (3) and motor (10) to the motor mount plate (38) using bolts (41), washers (42) and nuts (37).

**Figure 2-10** *Installing the pulley, belts and motor to the motor frame*

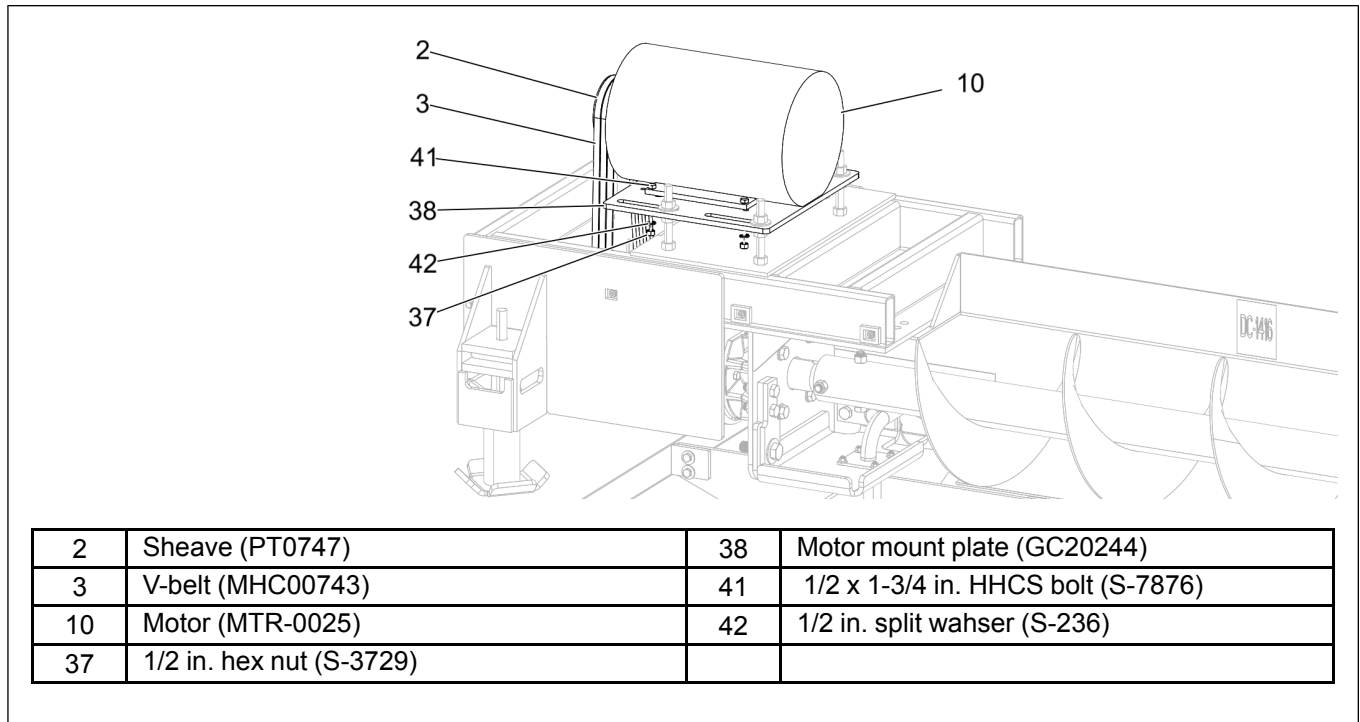

13. Install the motor cover (43) to the motor frame (33) along with the end panels (44) using the bolts (45).

**Figure 2-11** *Installing the motor cover and end panels to the motor frame*

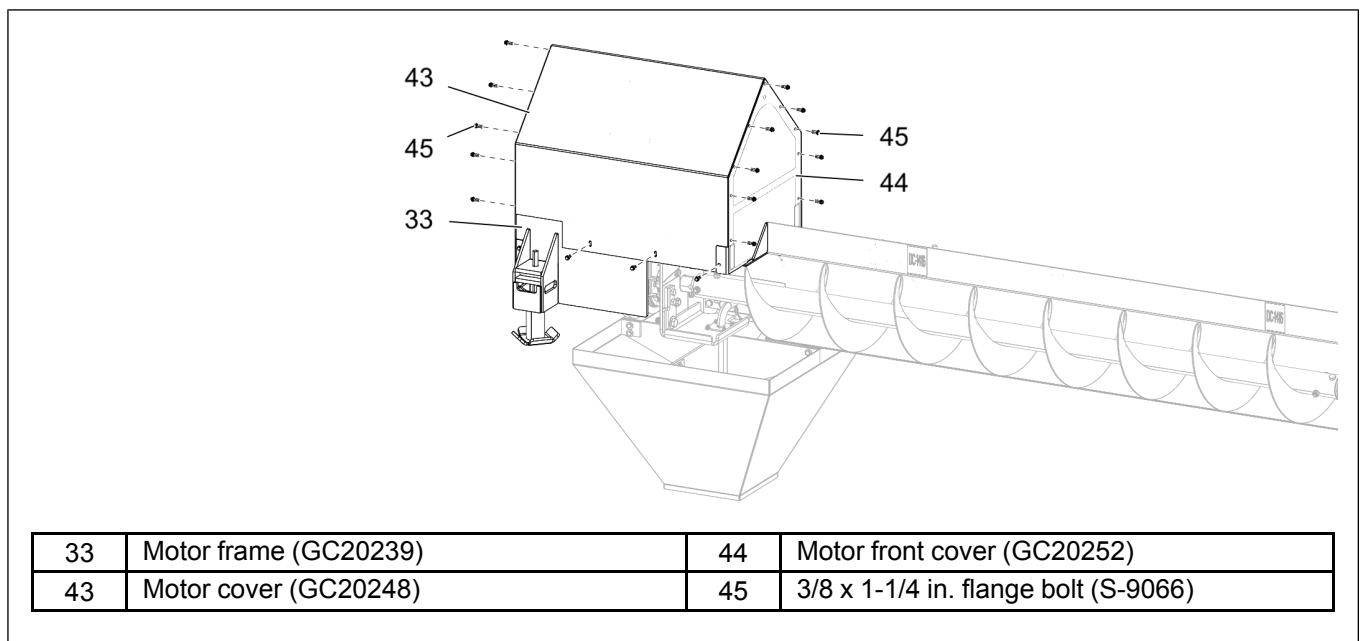

14. Field cut the diagonal tube of section frame for the supplied dimensions to install the rear support, wheel assembly and front wheel strut.

**Figure 2-12** Position of wheel assembly, rear support and front wheel strut

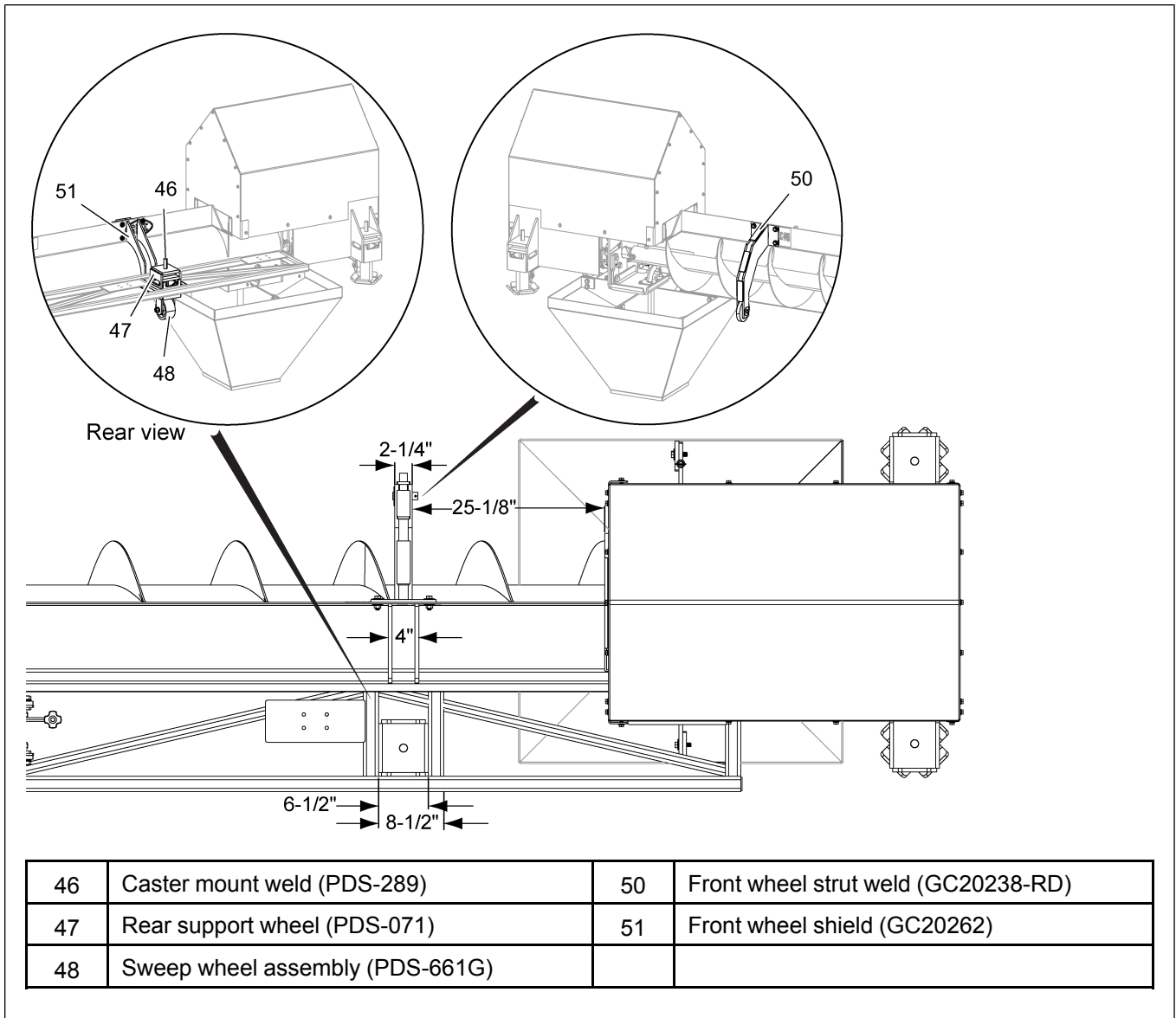

## Chapter 2: Motor Frame Swap Instructions

15. Position the front wheel strut (50) against the backshield to the supplied dimensions and field drill four (4) holes for 1/2 in. bolts to attach the front wheel strut.

**Figure 2-13** Field drill holes for front wheel strut

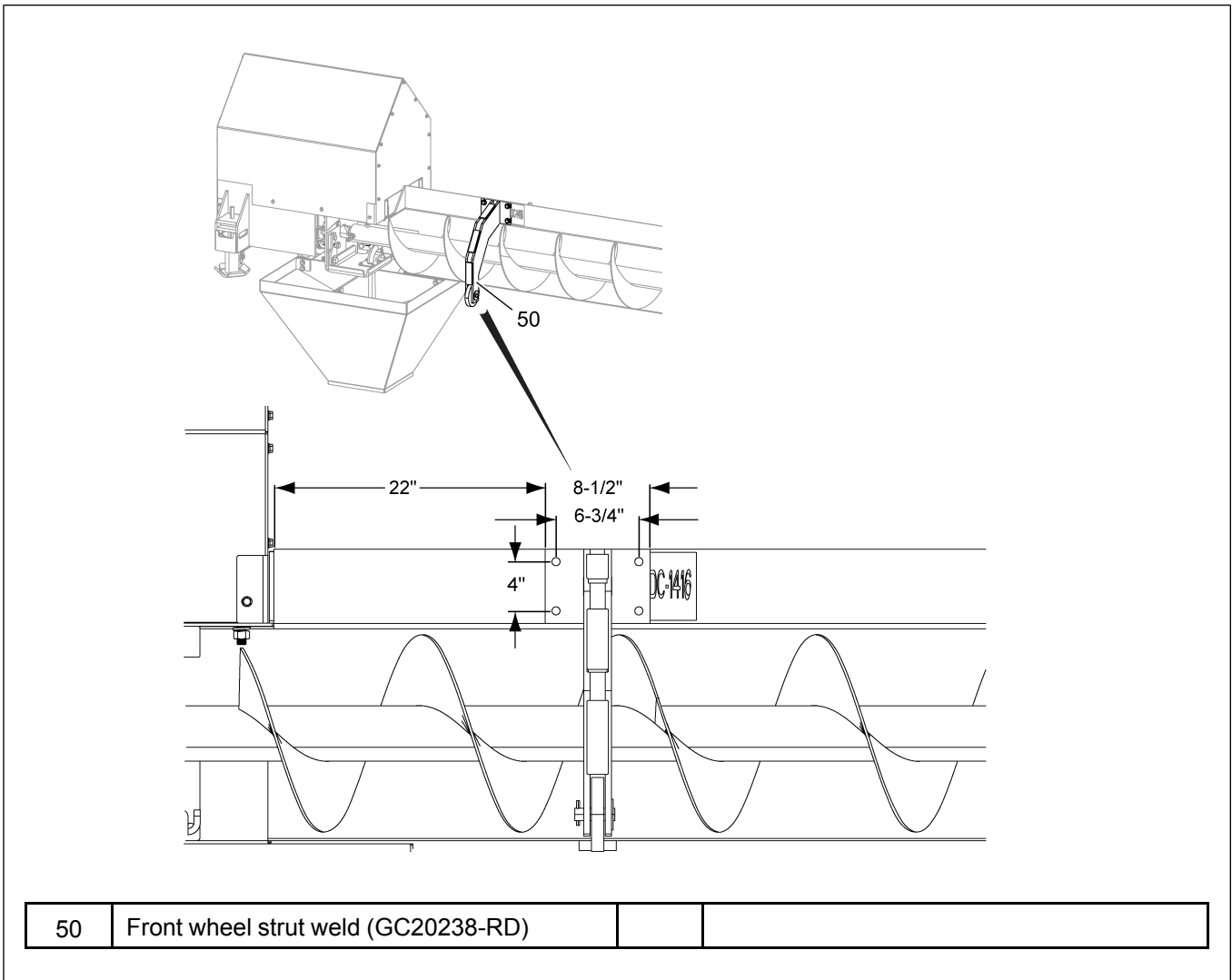

16. Weld the rear support (47) and wheel assembly (48) to the section frame.

**NOTE:** Field cut the angular frame tube as required to allow the positioning of support wheel.

17. Weld the short frame tube (49) to the section frame.

**Figure 2-14** Welding the rear support and wheel assembly

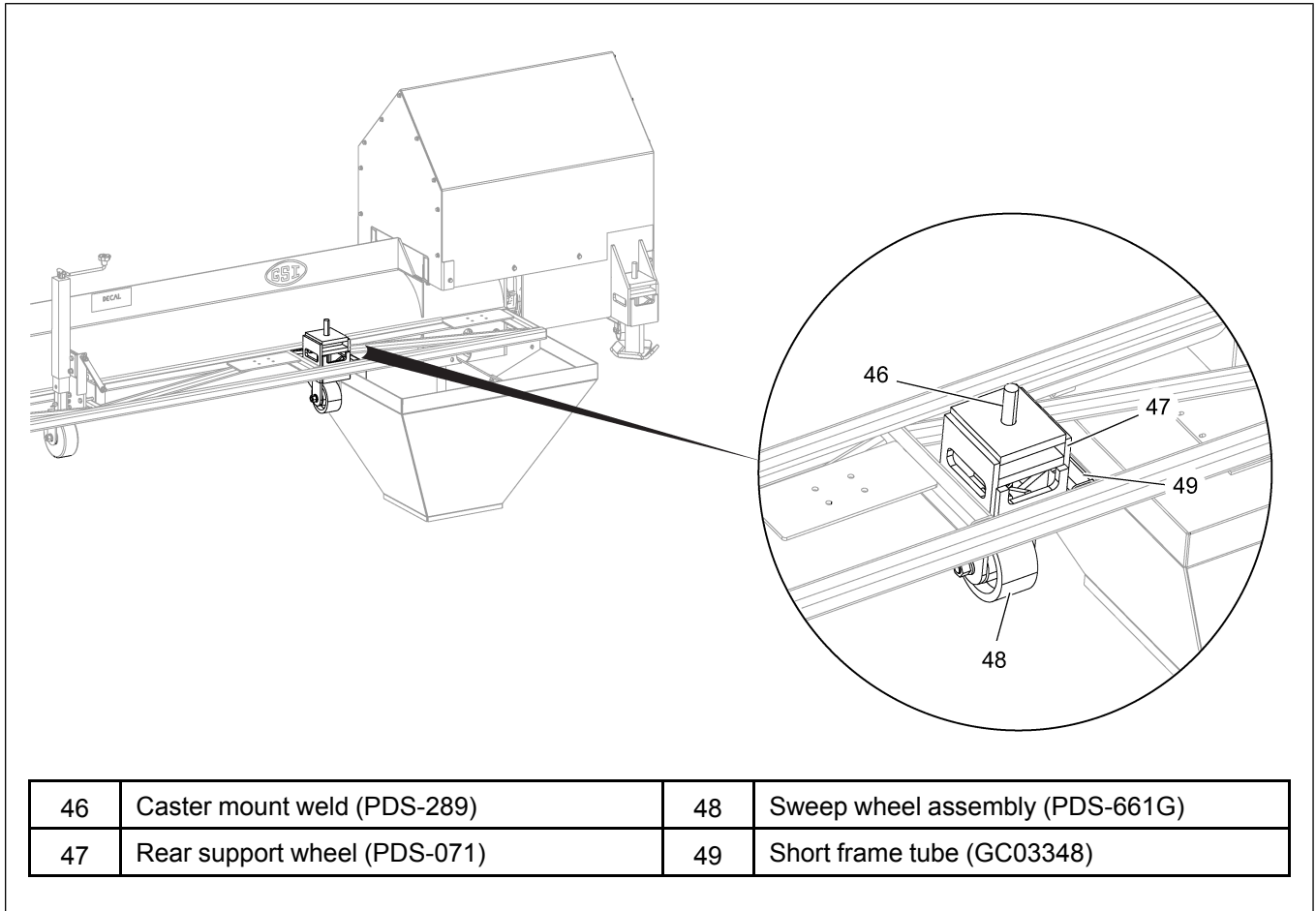

## Chapter 2: Motor Frame Swap Instructions

18. Install the front wheel strut (50) to the backshield using bolts (35), washers (36) and nuts (37).
19. Position the two (2) front wheel shield supports (51) to the supplied dimensions and weld it to the backshield. Refer to [Figure 2-12, page 19](#).

**Figure 2-15** Assembling the front wheel strut

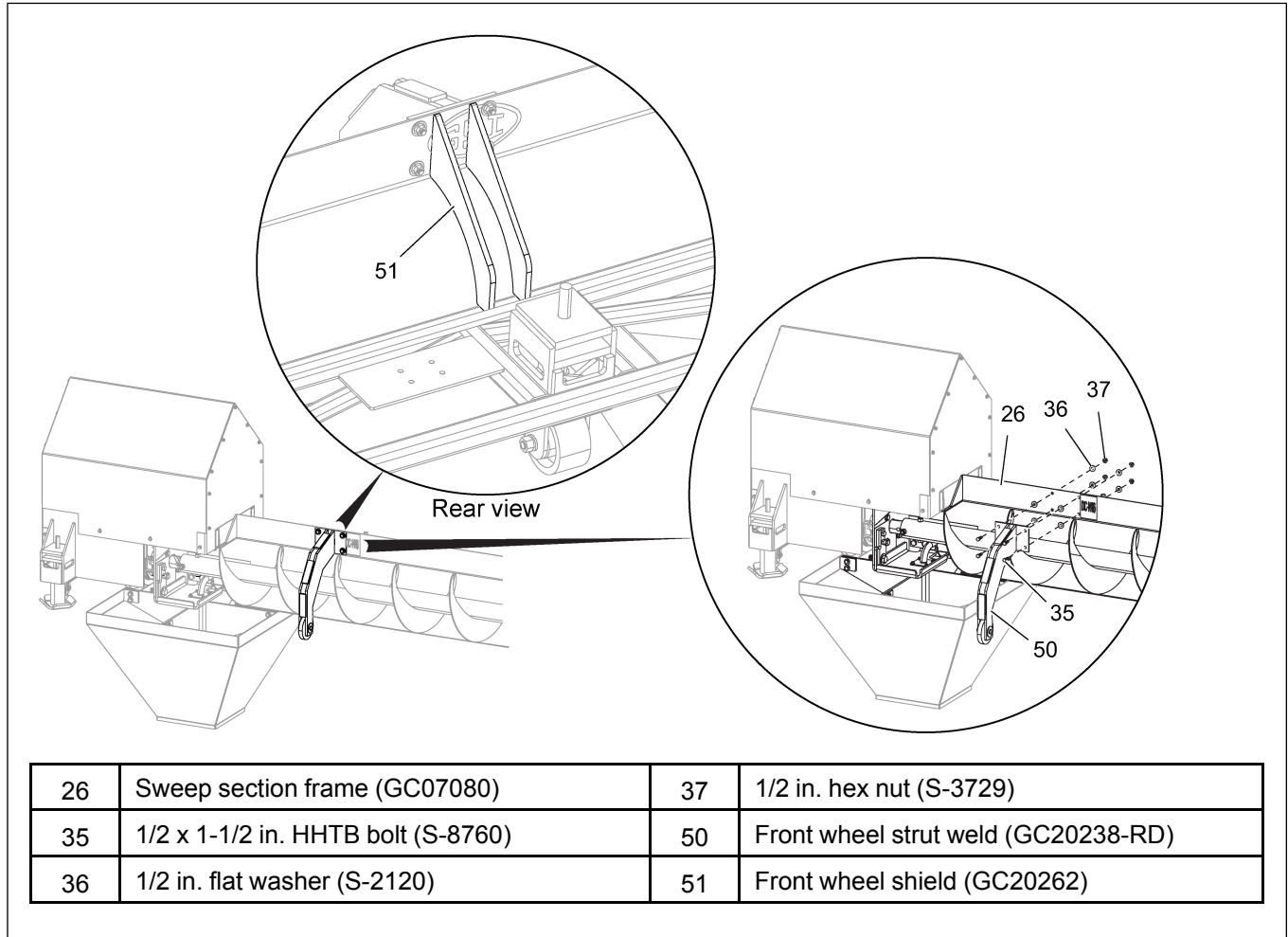

20. Repeat the steps from 14 - 19 to install the sweep wheel strut and wheel supports for each section of sweep.

# 3 Parts List

## Topics Covered in this Chapter

- Series II Sweep Retrofit Kit Parts List





Table 3-1 Series II sweep retrofit kit parts list

Ref #	Part #	Description
1	GC20239	Series II Motor Mount Assembly - 16 in. Field Fix
2	PDS-289	X-Series Caster Mount Weldment Red
3	GC20247	X-Series Sweep Skid Weldment
4	GC20244	Series II Motor Mount Plate Field Fix
5	MTR-0025	Motor, 20 HP 3 PH 1750 RPM 1-5/8 in. Shaft
6	S-7876	1/2 x 1-3/4 in. HHCS Bolt
7	S-236	1/2 in. Split Lock Washer
8	S-3729	1/2 in. Hex Nut
9	S-866	3/4 in. Flat Washer
10	S-234	3/4 in. Hex Nut
11	GC20253	Series II Sweep Auger Motor Back Cover
12	GC20248	Series II Sweep Auger Motor Cover Weldment
13	GC20252	Series II Sweep Auger Motor Front cover
14	S-9066	3/8 x 1-1/4 in. Flange Bolt
15	S-869	3/4 x 2 in. HHCS Bolt
16	S-233	3/4 in. Split Lock Washer
17	S-8127	3/4 x 3 in. HHCS Bolt
18	S-7622	1-8 in. x 3-1/2 HHCS Bolt
19	S-7835	1 in. ID Flat Washer
20	GC20235-BS	Series II Sweep - Pivot Pipe Weldment - 16 in. 50K Field Fix
21	PDS-359	X-Series Sweep HD Pivot Plate
22	GC07080	Series II Sweep HD SEC 16 x 144 in. Pivot
23	S-8418	1-8 in. Nylock Nut
24	PDS-071	Rear Support Wheel Strut
25	PDS-661G	X-Series Sweep Wheel Assembly
26	GC20262	Series II Sweep Front Wheel Shield Support - 16 in.
27	GC20238	Series II Sweep Front Wheel Strut Weldment - 16 in. Field Fix
28	PDS-054	X-Series Sweep Front Support Wheel Machined
29	PDS-341	X-Series Front Wheel Pin Weldment
30	S-1341	3/16 x 2 in. Slotted Rolled Spring Pin
31	S-8760	1/2 x 1-1/2 in. HHTB Bolt
32	S-2121	1/2 in. Flat Washer
33	S-8506	1/2 in. Flange Nut
34	GC06851	Series II Sweep Coil Ring Sump Brace
35	PDS-079	Plate Slot Spacer
36	PDS-078	Plate Pivot Slot
N/S	GC03348	188 x 2 x 2 x 12 in. Tube

---

# NOTES

## GSI Group, LLC Limited Warranty

The GSI Group, LLC (“GSI”) warrants products which it manufactures to be free of defects in materials and workmanship under normal usage and conditions for a period of 12 months after sale to the original end-user or if a foreign sale, 14 months from arrival at port of discharge, whichever is earlier. The end-user’s sole remedy (and GSI’s only obligation) is to repair or replace, at GSI’s option and expense, products that in GSI’s judgment, contain a material defect in materials or workmanship. Expenses incurred by or on behalf of the end-user without prior written authorization from the GSI Warranty Group shall be the sole responsibility of the end-user.

**Warranty Extensions:** The Limited Warranty period is extended for the following products:

	Product	Warranty Period
AP Fans and Flooring	Performer Series Direct Drive Fan Motor	3 Years
	All Fiberglass Housings	Lifetime
	All Fiberglass Propellers	Lifetime
AP/Cumberland	Flex-Flo/Pan Feeding System Motors	2 Years
Cumberland Feeding/Watering Systems	Feeder System Pan Assemblies	5 Years **
	Feed Tubes (1-3/4" and 2.00")	10 Years *
	Centerless Augers	10 Years *
	Watering Nipples	10 Years *
Grain Systems	Grain Bin Structural Design	5 Years
Grain Systems Farm Fans Zimmerman	Portable and Tower Dryers	2 Years
	Portable and Tower Dryer Frames and Internal Infrastructure †	5 Years

\* Warranty prorated from list price:  
0 to 3 years - no cost to end-user  
3 to 5 years - end-user pays 25%  
5 to 7 years - end-user pays 50%  
7 to 10 years - end-user pays 75%

\*\* Warranty prorated from list price:  
0 to 3 years - no cost to end-user  
3 to 5 years - end-user pays 50%

† Motors, burner components and moving parts not included.  
Portable dryer screens included.  
Tower dryer screens not included.

GSI further warrants that the portable and tower dryer frame and basket, excluding all auger and auger drive components, shall be free from defects in materials for a period of time beginning on the twelfth (12<sup>th</sup>) month from the date of purchase and continuing until the sixtieth (60<sup>th</sup>) month from the date of purchase (extended warranty period). During the extended warranty period, GSI will replace the frame or basket components that prove to be defective under normal conditions of use without charge, excluding the labor, transportation, and/or shipping costs incurred in the performance of this extended warranty.

### Conditions and Limitations:

THERE ARE NO WARRANTIES THAT EXTEND BEYOND THE LIMITED WARRANTY DESCRIPTION SET FORTH ABOVE. SPECIFICALLY, GSI MAKES NO FURTHER WARRANTY OF ANY KIND, EXPRESS OR IMPLIED, INCLUDING, WITHOUT LIMITATION, WARRANTIES OF MERCHANTABILITY OR FITNESS FOR A PARTICULAR PURPOSE OR USE IN CONNECTION WITH: (I) PRODUCT MANUFACTURED OR SOLD BY GSI OR (II) ANY ADVICE, INSTRUCTION, RECOMMENDATION OR SUGGESTION PROVIDED BY AN AGENT, REPRESENTATIVE OR EMPLOYEE OF GSI REGARDING OR RELATED TO THE CONFIGURATION, INSTALLATION, LAYOUT, SUITABILITY FOR A PARTICULAR PURPOSE, OR DESIGN OF SUCH PRODUCTS.

GSI shall not be liable for any direct, indirect, incidental or consequential damages, including, without limitation, loss of anticipated profits or benefits. The sole and exclusive remedy is set forth in the Limited Warranty, which shall not exceed the amount paid for the product purchased. This warranty is not transferable and applies only to the original end-user. GSI shall have no obligation or responsibility for any representations or warranties made by or on behalf of any dealer, agent or distributor.

GSI assumes no responsibility for claims resulting from construction defects or unauthorized modifications to products which it manufactured. Modifications to products not specifically delineated in the manual accompanying the equipment at initial sale will void the Limited Warranty.

This Limited Warranty shall not extend to products or parts which have been damaged by negligent use, misuse, alteration, accident or which have been improperly/inadequately maintained. This Limited Warranty extends solely to products manufactured by GSI.

Prior to installation, the end-user has the responsibility to comply with federal, state and local codes which apply to the location and installation of products manufactured or sold by GSI.

9101239\_1\_CR\_rev8.xml (revised January 2014)

**This equipment shall be installed in accordance with the current installation codes and applicable regulations which should be carefully followed in all cases. Authorities having jurisdiction should be consulted before installations are made.**



1004 E. Illinois St.  
Assumption, IL 62510-0020  
Phone: 1-217-226-4421  
Fax: 1-217-226-4420  
[www.gsiag.com](http://www.gsiag.com)



GSI is a worldwide brand of AGCO Corporation.