

# Chain Loop Power Sweep

**Models:**  
8", 10" AND 12"

Installation and Operation Manual

**PNEG-2212**

**Version 1.0**

**Date: 07-24-18**



PNEG-2212

---

**All information, illustrations, photos, and specifications in this manual are based on the latest information available at the time of publication. The right is reserved to make changes at any time without notice.**

---

# Contents

<b>Chapter 1</b>	<b>Safety Precautions</b> .....	<b>5</b>
	Safety Guidelines .....	5
	Cautionary Symbol Definitions.....	6
	Safety Cautions.....	7
	Safety Decals .....	10
	Safety Sign-off Sheet.....	12
<b>Chapter 2</b>	<b>General Information</b> .....	<b>13</b>
	Sweep Offerings and Sweep Arm Details .....	13
	Short Sweeps .....	14
<b>Chapter 3</b>	<b>Installation</b> .....	<b>15</b>
	Power Sweeps in Bins with Concrete Floors.....	16
	Installing the Center Well .....	17
	Installing the Bin Flange for Unload Tube .....	19
	Intermediate Well Layout .....	22
	Installing the Intermediate Well.....	23
	Control Rod Layout .....	24
	Installing the Center Well Gate .....	25
	Installing the Intermediate Well Gate.....	26
	Installing the Auxiliary Intermediate Well (Optional).....	28
	Connecting the Control Rods .....	34
	Installing the Single Rack and Pinion (30 ft - 39 ft).....	35
	Installing the Double Rack and Pinion (42 ft - 72 ft) .....	42
	Installing Intermediate Well Flanges .....	46
	Assembling the Sweep Flighting to the Backshield (60 ft - 72 ft Bins).....	47
	Assembling the Sweep Support Skid .....	49
	Installing the Sweep Flighting.....	50
	Installing the Flighting Shield.....	53
	Installing the Sweep Wheel.....	54
	Adjusting the Wiper .....	56
	Adjusting the Sweep Support Skid.....	58
	Installing the Backshield Support Assembly.....	59
	Drive Assembly and Power Tube Layout.....	61
	Installing the Power Tube.....	62
	Assembling the Drive Shafts (42 ft - 72 ft Only) .....	64
	Installing the Bin Flanges for Power tube.....	66
	Assembling the Drive Head.....	68
<b>Chapter 4</b>	<b>Operation</b> .....	<b>75</b>
	Power Recommendations .....	75
	Before Filling the Bin .....	76
	Performing Pre-Start Checks.....	78
	Operating the Auger .....	79
	Final Clean Out.....	82
<b>Chapter 5</b>	<b>Shut Down</b> .....	<b>83</b>
	Normal Shut Down .....	83
	Emergency Shut Down .....	83
	Storage Preparation .....	83
<b>Chapter 6</b>	<b>Maintenance and Troubleshooting</b> .....	<b>85</b>
	Maintaining the Auger.....	85
	Troubleshooting .....	86
<b>Chapter 7</b>	<b>Parts List</b> .....	<b>87</b>
	Center Well.....	88
	Intermediate Well .....	90
	Outside Intermediate Well (For 42 ft and Larger Bins) .....	91

---

Auxiliary Kits (Optional).....	92
Single Rack and Pinion (30 ft - 36 ft) .....	96
Double Rack and Pinion (42 ft - 72 ft).....	98
Bin Flange .....	100
Sweep Wheel .....	101
Backshield with Two Augers (30 ft Bins).....	102
Backshield with Three Augers (33 ft - 42 ft Bins) .....	104
Backshield with Four Augers (48 ft Bins) .....	106
Backshield with Four Augers (54 ft Bins) .....	108
Backshield with Five Augers (60 ft Bins).....	110
Backshield with Five Augers (66 Ft Bins).....	112
Backshield with Six Augers (72 ft Bins) .....	114
Drive Head .....	116
Backshield Connections .....	118
<b>GSI Group, LLC Limited Warranty .....</b>	<b>119</b>



# 1 Safety Precautions

## Topics Covered in this Chapter

- Safety Guidelines
- Cautionary Symbol Definitions
- Safety Cautions
- Safety Decals
- Safety Sign-off Sheet

## Safety Guidelines

Safety guidelines are general-to-specific safety rules that must be followed at all times. This manual is written to help you understand safe operating procedures and problems that can be encountered by the operator and other personnel when using this equipment. Save these safety guidelines for future reference.

As owner or operator, you are responsible for understanding the requirements, hazards, and precautions that exist and to inform others as required. Unqualified persons must stay out of the work area at all times.

Alterations must not be made to the equipment. Alterations can produce dangerous situations resulting in **SERIOUS INJURY** or **DEATH**.

This equipment must be installed in accordance with the current installation codes and applicable regulations, which must be carefully followed in all cases. Authorities having jurisdiction must be consulted before installations are made.

When necessary, you must consider the installation location relative to electrical, fuel and water utilities.








Personnel operating or working around equipment must read this manual. This manual must be delivered with equipment to its owner. Failure to read this manual and its safety instructions is a misuse of the equipment.

ST-0001-3

## Cautionary Symbol Definitions

Cautionary symbols appear in this manual and on product decals. The symbols alert the user of potential safety hazards, prohibited activities and mandatory actions. To help you recognize this information, we use the symbols that are defined below.

**Table 1-1** Description of the different cautionary symbols








Symbol	Description
	This symbol indicates an imminently hazardous situation which, if not avoided, <b>will result in serious injury or death.</b>
	This symbol indicates a potentially hazardous situation which, if not avoided, <b>can result in serious injury or death.</b>
	This symbol indicates a potentially hazardous situation which, if not avoided, <b>can result in minor or moderate injury.</b>
	This symbol is used to address practices not related to personal injury.
	This symbol indicates a general hazard.
	This symbol indicates a prohibited activity.
	This symbol indicates a mandatory action.

ST-0005-2

## Safety Cautions

### Use Personal Protective Equipment

- Use appropriate personal protective equipment:

<b>Eye Protection</b>		<b>Respiratory Protection</b>		<b>Foot Protection</b>	
<b>Hearing Protection</b>		<b>Head Protection</b>		<b>Fall Protection</b>	
<b>Hand Protection</b>					

- Wear clothing appropriate to the job.
- Remove all jewelry.
- Tie long hair up and back.

ST-0004-1

### Follow Safety Instructions

- Carefully read all safety messages in this manual and safety signs on your machine. Keep signs in good condition. Replace missing or damaged safety signs. Be sure new equipment components and repair parts include the current safety signs. Replacement safety signs are available from the manufacturer.
- Learn how to operate the machine and how to use controls properly. Do not let anyone operate without instruction.
- If you do not understand any part of this manual or need assistance, contact your dealer.



ST-0002-1

## Chapter 1: Safety Precautions

### Maintain Equipment and Work Area

- Understand service procedures before doing work. Keep area clean and dry.
- Never service equipment while it is operating. Keep hands, feet, and clothing away from moving parts.
- Keep your equipment in proper working condition. Replace worn or broken parts immediately.



ST-0003-1

### Operate Motor Properly

- All electrical connections must be made in accordance with applicable local codes (National Electrical Code for the US, Canadian Electric Code, or EN60204 along with applicable European Directives for Europe). Make sure equipment and bins are properly grounded.
- Lock-out power before resetting motor overloads.
- Do not repetitively stop and start the drive in order to free a plugged condition. Jogging the drive in this manner can damage the equipment and drive components.



ST-0009-3

### Rotating Auger Hazard

- Keep clear of rotating augers and moving parts.
- Do not remove or modify guards or covers.
- Lock-out power source before making adjustments, cleaning, or maintaining equipment.
- Failure to follow these precautions will result in serious injury or death.



ST-0037-1

### Stay Clear of Hoisted Equipment

- Always use proper lifting or hoisting equipment when assembling or disassembling equipment
- Do not walk or stand under hoisted equipment.
- Always use sturdy and stable supports when needed for installation. Not following these safety precautions creates the risk of falling equipment, which can crush personnel and cause serious injury or death.



ST-0047-1

**Stay Clear of Rotating Parts**

- Do not enter the bin while the equipment is in operation.
- Entanglement in rotating augers will cause serious injury or death.
- Keep all guards and covers in place at all times.
- Lock-out power source before making adjustments, cleaning, or maintaining equipment.



ST-0008-2

**Use Unload Equipment Properly**

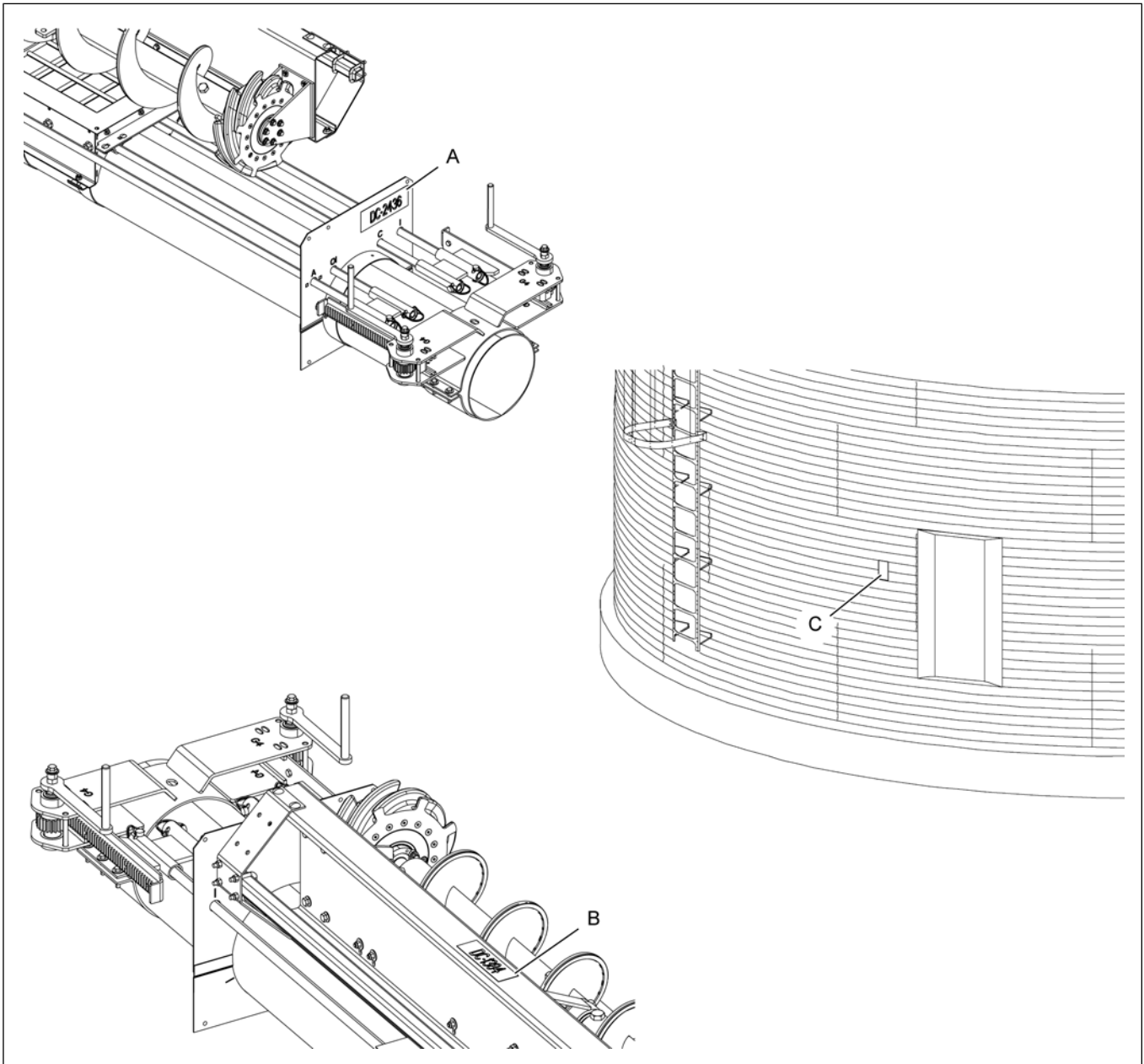
- Do not operate this equipment alone. Make sure someone nearby is aware of the proper shut down sequence in the event of an emergency.
- Do not allow any person intoxicated or under the influence of drugs to operate this equipment. All operators must be adequately rested and prepared to perform all functions of operating the equipment.
- Do not start equipment until all persons are clear of the work area and safety guards are in place.
- Do not allow anyone inside a bin, truck, or wagon which is being unloaded by an auger. Flowing grain can trap and suffocate in seconds.
- Use ample overhead lighting after sunset to light the work area.
- Always use caution to not hit the auger when positioning the load.
- Do not leave equipment operating while unattended.
- Be aware of pinch points, which can trap or catch objects and cause injury.
- Be sure all equipment is locked in position before operating.
- Always lock out all power sources to the equipment when unloading is finished.




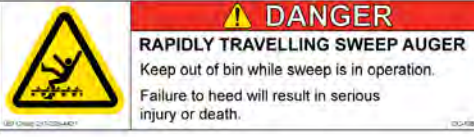

ST-0051-1

### Safety Decals

Check components shown below to ensure that the safety decals are in place and in good condition. If a decal cannot be easily read for any reason or has been painted over, replace it immediately. Contact your dealer or the manufacturer to order a replacement decal free of charge.





Ref #	Location	Decal No.	Decal	Description
A	Upper bin flange	DC-2436		Decal, Danger Sweep auger
B	Flighting shield top	DC-1384		Decal, keep out of bin
C	Bin sidewall	DC-1395		Decal, rotating flight

To replace a damaged or missing decal, contact us to receive a free replacement.

**GSI Decals**

1004 E. Illinois St.  
 Assumption, IL 62510  
 Tel: 1-217-226-4421





# 2 General Information

## Topics Covered in this Chapter

- Sweep Offerings and Sweep Arm Details
- Short Sweeps

## Sweep Offerings and Sweep Arm Details

When sweep is used with standard 2-ring farm door on all plenum heights, standard sweep length can be used.

Figure 2-1 Sweep details

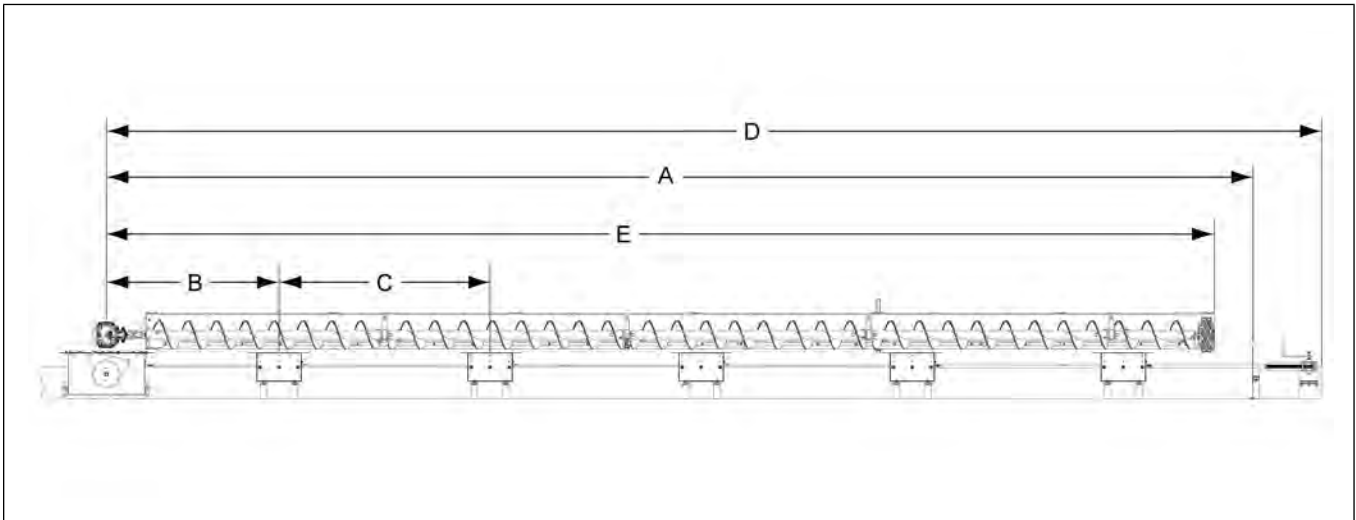


Table 2-1 Details for 10 in.

Bin diameter	# of intermediate wells	Distance from center of bin to wall (A)	Distance between center of bin and first intermediate well (B)	Distance between intermediate wells (C)	Distance from center of bin to tube end (D)	Distance between center of bin to end of sweep (E)
30'	2	14' - 11-17/32"	6' - 6"	72"	16' - 8-3/16"	14' - 7-1/16"
33'	3	16' - 5-1/2"	4' - 6-1/4"	48"	18' - 2-1/8"	16' - 1-1/16"
36'	3	17' - 11-3/8"	4' - 6"	60"	19' - 8"	17' - 6-9/16"
39'	3	16' - 5-3/8"	5' - 4-1/4"	42"	18' - 1-1/16"	16' - 9/16"
42'	4	20' - 11-3/16"	4' - 6"	54"	22' - 7-13/16"	20' - 6-1/16"
48'	4	23' - 11"	5'	62"	25' - 7-5/8"	23' - 6-1/16"
54'	4	26' - 10-13/16"	5'	66"	28' - 7-7/16"	26' - 6-1/16"
60'	5	29' - 10-5/8"	5'	66"	31' - 7-1/4"	29' - 6-1/16"
66'	6	35' - 10-1/2"	4'	60"	34' - 7-1/8"	32' - 6-1/16"
72'	6	35' - 10-5/16"	4'	60"	37' - 6-15/16"	35' - 5-1/16"

## Short Sweeps

A shortened sweep is required when using welded sleeve or double frame door with a plenum other than 12 in. The sweep arm is shortened approximately 7 in. from standard length for short sweep.

Figure 2-2 Short sweep details

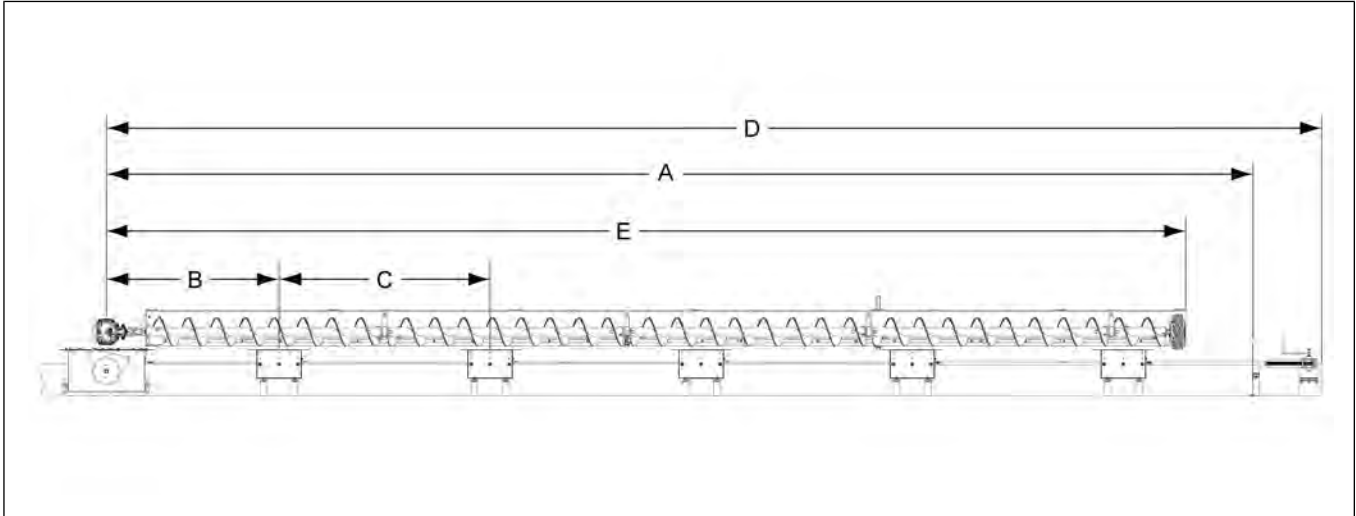


Table 2-2 Details for 10 in.

Bin diameter	# of intermediate wells	Distance from center of bin to wall (A)	Distance between center of bin and first intermediate well (B)	Distance between intermediate wells (C)	Distance from center of bin to tube end (D)	Distance between center of bin to end of sweep (E)
30'	2	14' - 11-17/32"	6' - 6"	72"	16' - 8-3/16"	14' - 1/16"
33'	3	16' - 5-1/2"	4' - 6-1/4"	48"	18' - 2-1/8"	15' - 6-1/16"
36'	3	17' - 11-3/8"	4' - 6"	60"	19' - 8"	16' - 11-9/16"
39'	3	16' - 5-3/8"	5' - 4-1/4"	42"	18' - 1-1/16"	15' - 5-9/16"
42'	4	20' - 11-3/16"	4' - 6"	54"	22' - 7-13/16"	19' - 11-1/16"
48'	4	23' - 11"	5'	62"	25' - 7-5/8"	22' - 11-1/16"
54'	4	26' - 10-13/16"	5'	66"	28' - 7-7/16"	25' - 11-1/16"
60'	5	29' - 10-5/8"	5'	66"	31' - 7-1/4"	28' - 11-1/16"
66'	6	35' - 10-1/2"	4'	60"	34' - 7-1/8"	31' - 11-1/16"
72'	6	35' - 10-5/16"	4'	60"	37' - 6-15/16"	34' - 10-1/16"

# 3 Installation

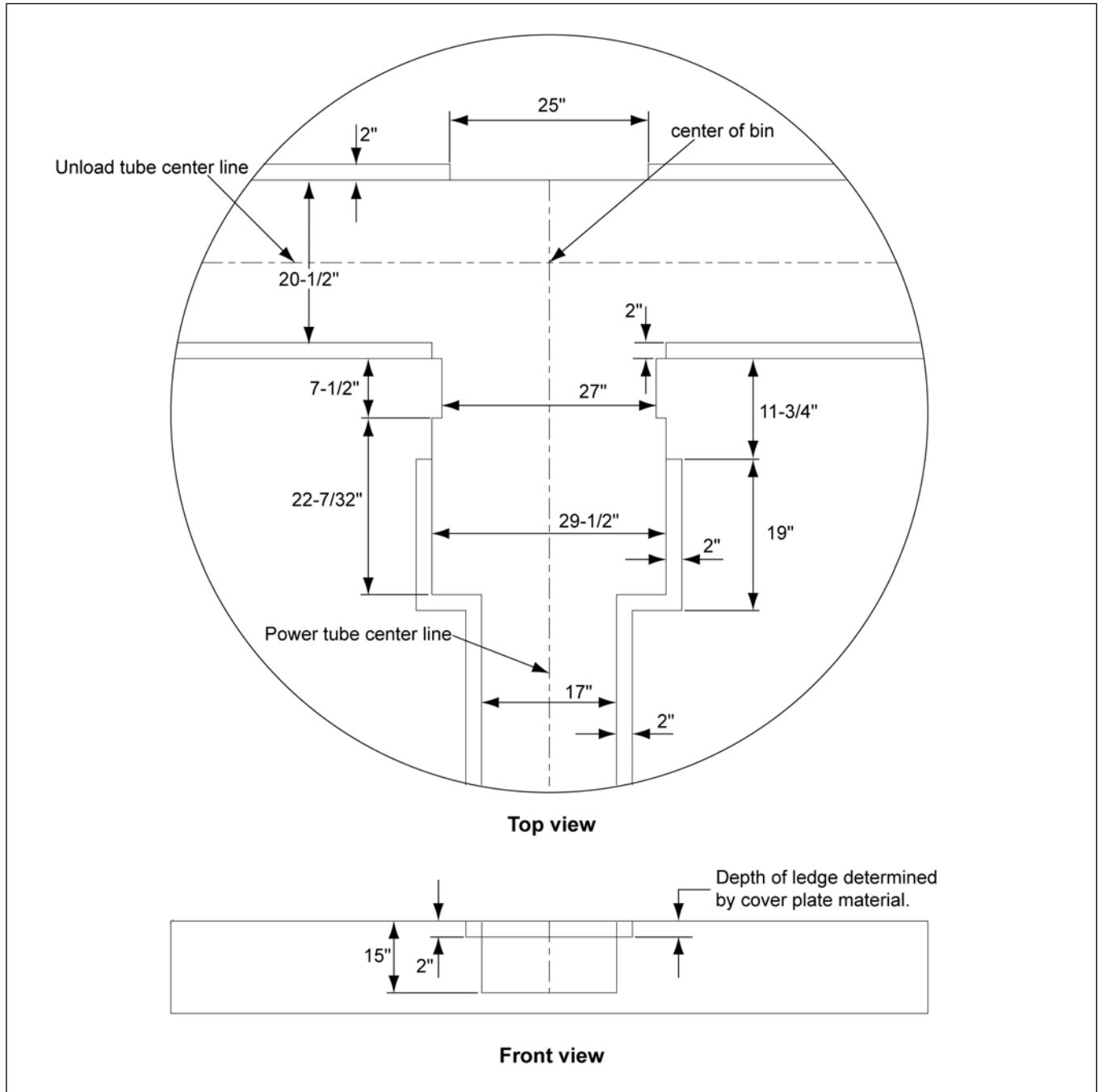
## Topics Covered in this Chapter

- Power Sweeps in Bins with Concrete Floors
- Installing the Center Well
- Installing the Bin Flange for Unload Tube
- Intermediate Well Layout
- Installing the Intermediate Well
- Control Rod Layout
- Installing the Center Well Gate
- Installing the Intermediate Well Gate
- Installing the Auxiliary Intermediate Well (Optional)
- Connecting the Control Rods
- Installing the Single Rack and Pinion (30 ft - 39 ft)
- Installing the Double Rack and Pinion (42 ft - 72 ft)
- Installing Intermediate Well Flanges
- Assembling the Sweep Flighting to the Backshield (60 ft - 72 ft Bins)
- Assembling the Sweep Support Skid
- Installing the Sweep Flighting
- Installing the Flighting Shield
- Installing the Sweep Wheel
- Adjusting the Wiper
- Adjusting the Sweep Support Skid
- Installing the Backshield Support Assembly
- Drive Assembly and Power Tube Layout
- Installing the Power Tube
- Assembling the Drive Shafts (42 ft - 72 ft Only)
- Installing the Bin Flanges for Power tube
- Assembling the Drive Head

## Power Sweeps in Bins with Concrete Floors

**NOTE:** GSI does not recommend installing the Direct Gear Drive Power Sweep in concrete. When flush-floor installations are necessary, a pre-formed trench is needed. A steel trench cover adequate for the grain height and trench size must be installed. Consult the factory for further information.

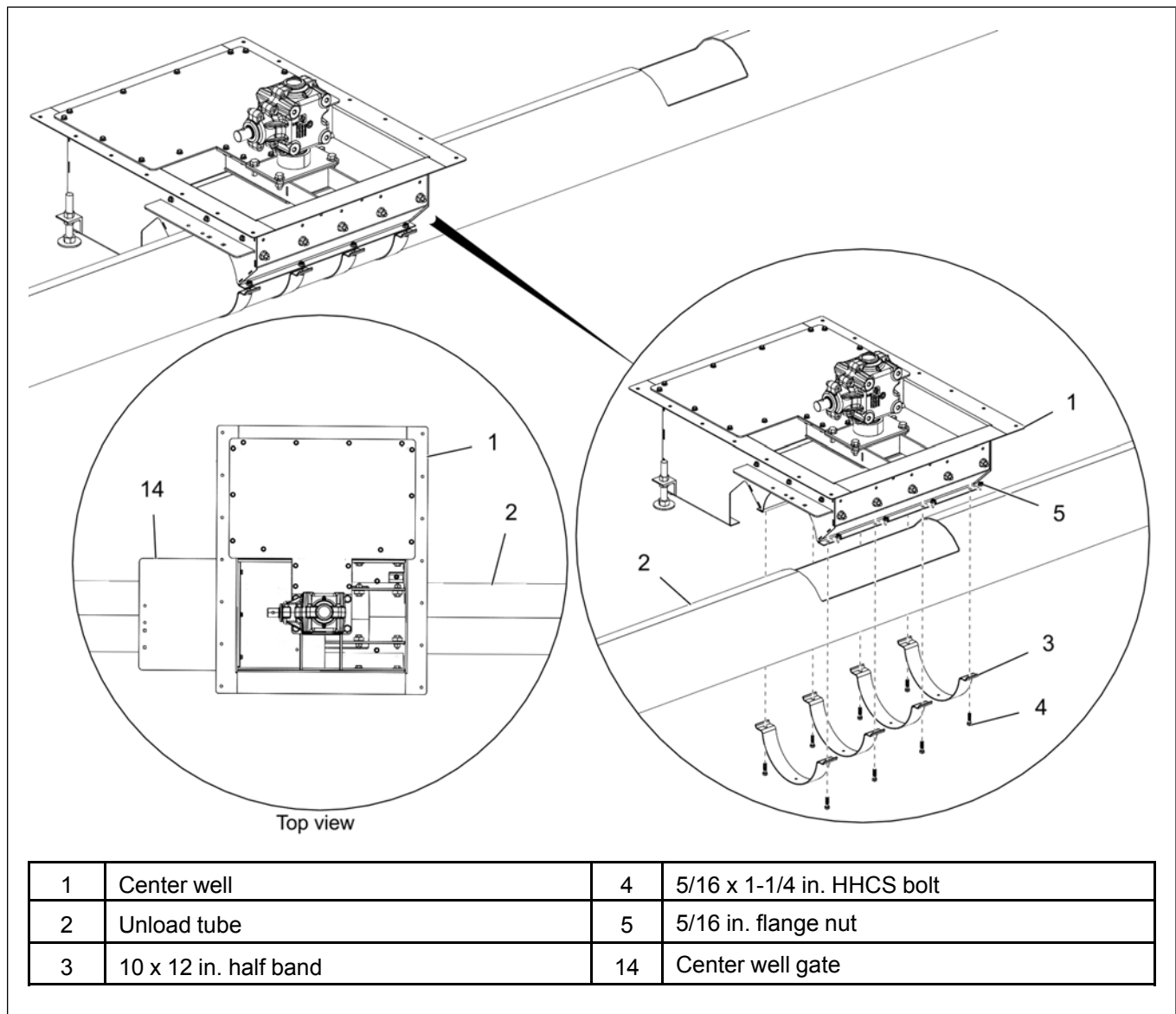
Figure 3-1 Power sweep dimensions - floor view



## Installing the Center Well

1. Locate the center of the bin and place the center well (1) into position with the vertical shaft in the gearbox at the center of the bin.
2. Attach the center well (1) to the unload tube (2) using four half bands (3), eight 5/16 x 1-1/4 in. HHCS bolts (4) and eight 5/16 in. flange nuts (5).

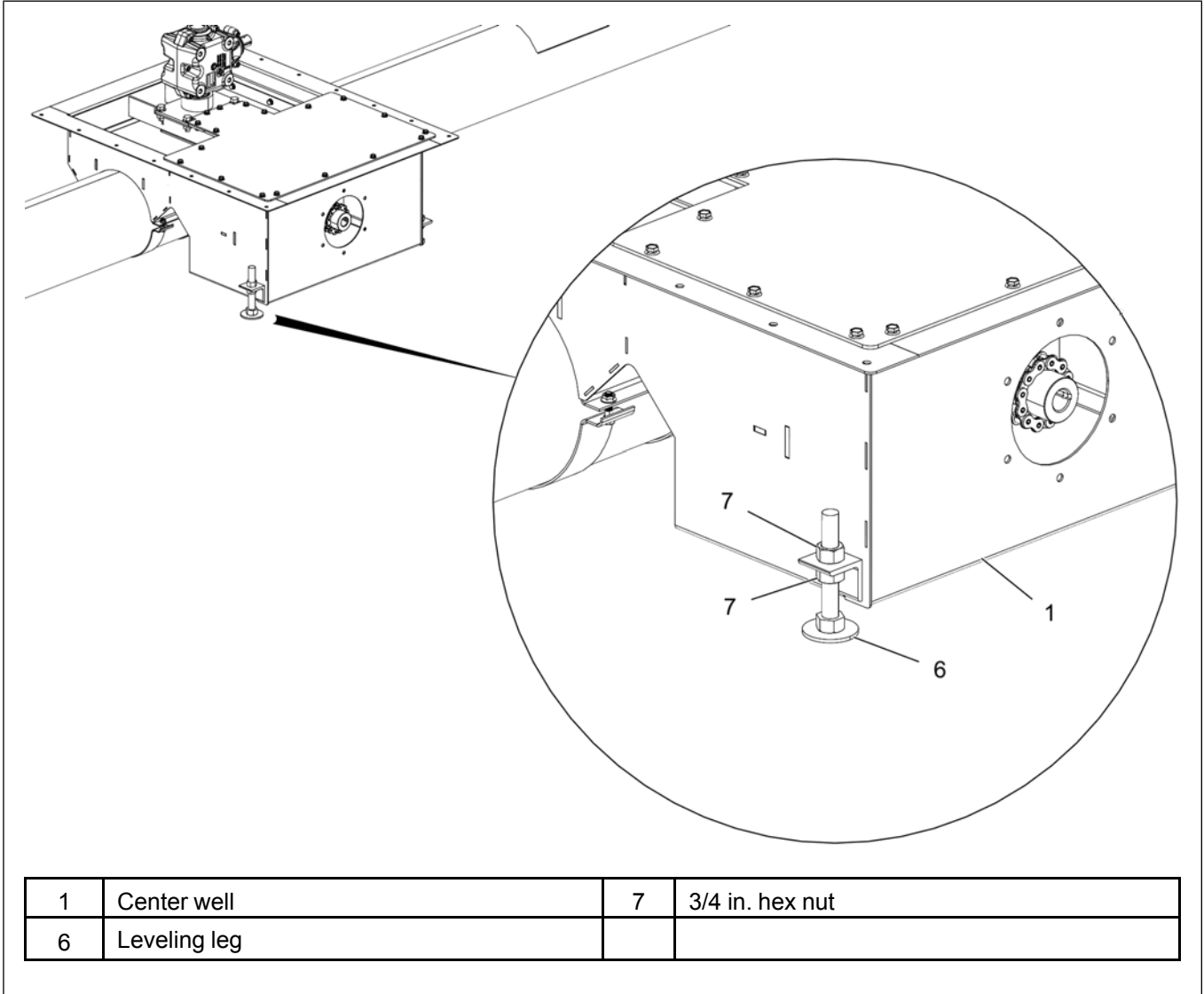
**Figure 3-2** Attaching the center well to the unload tube



## Chapter 3: Installation

- Level the center well (1) to the concrete floor by adjusting the length of the leveling leg (6) using both 3/4 in. hex nuts (7) (above and below the center well flange) located at the bottom corners of the center well (1).

**Figure 3-3** *Leveling of center well*



## Installing the Bin Flange for Unload Tube

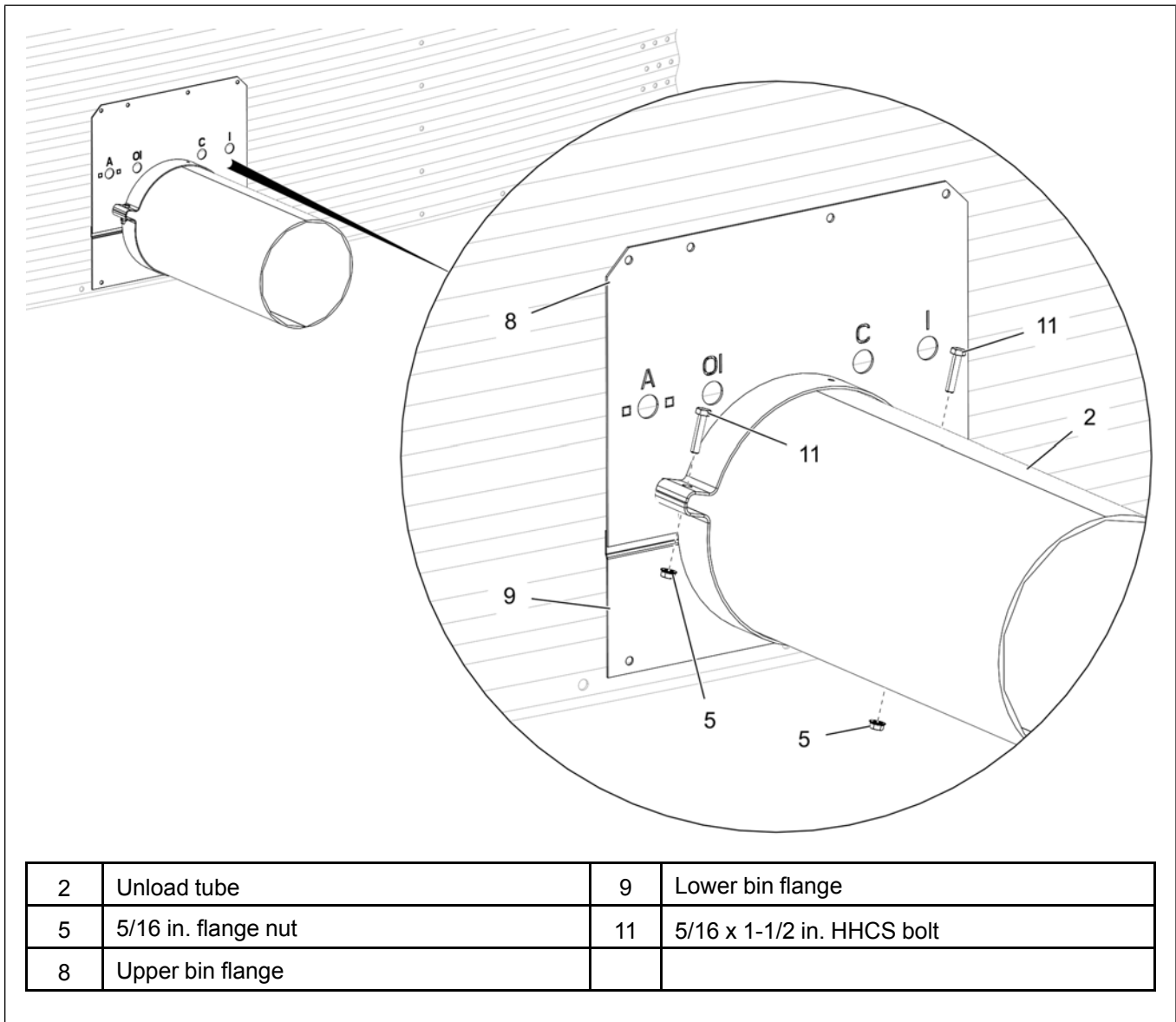
### Before You Begin

Knock out the holes in the upper bin flange for the center control rod to pass through.

1. Attach the upper bin flange (8) and lower bin flange (9) loosely to the unload tube (2) using 5/16 x 1-1/2 in. HHCS bolts (11) and 5/16 in. flange nuts (5).

**NOTE:** The upper bin flange (8) has knock out holes for both center well and intermediate well control rods. Install this upper bin flange (8) on the center well gate opening side.

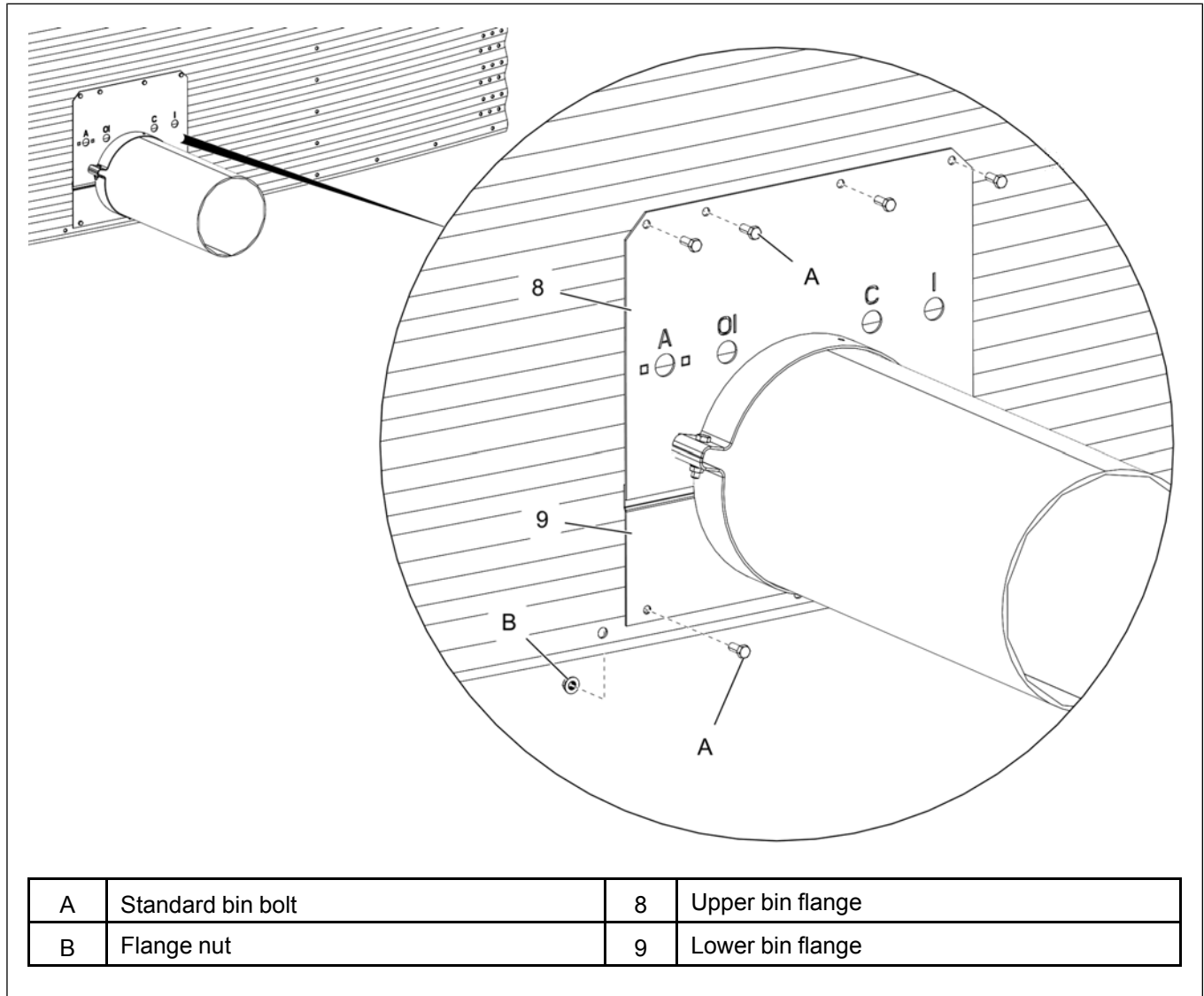
**Figure 3-4** Installing the upper and lower bin flanges (gate side)



## Chapter 3: Installation

2. Make sure that the bin wall opening is large enough for the well control rods to pass through the bin wall before connecting the flange to the bin wall.
3. Slide the bin flanges flush up to the bin wall and tighten the bolts connecting the two flanges.
4. Drill the holes in the bin wall through the four holes located in the upper bin flange (8) and two holes located in lower bin flange (9) and secure the bin flanges to the bin wall using six standard bin bolts (A) and flange nuts (B).

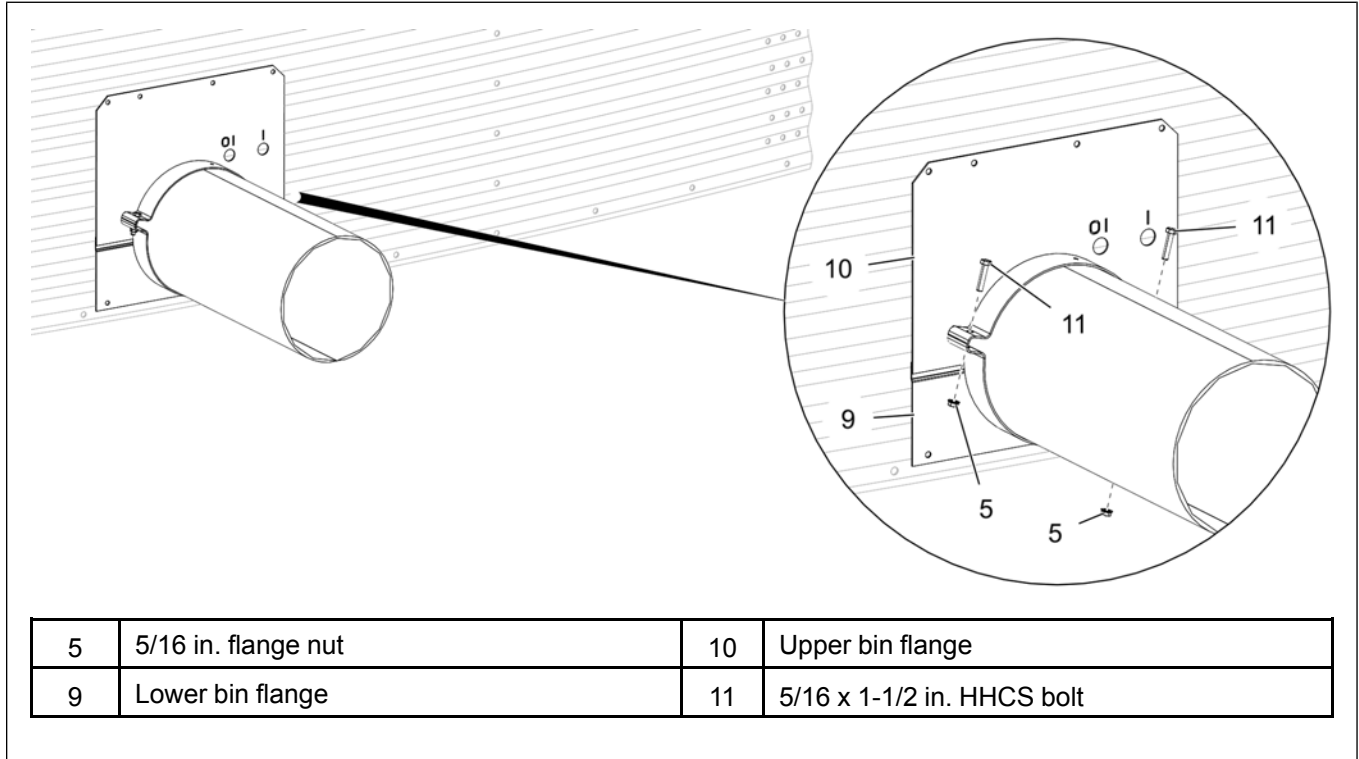
**Figure 3-5** Secure the upper and lower bin flanges (gate side)



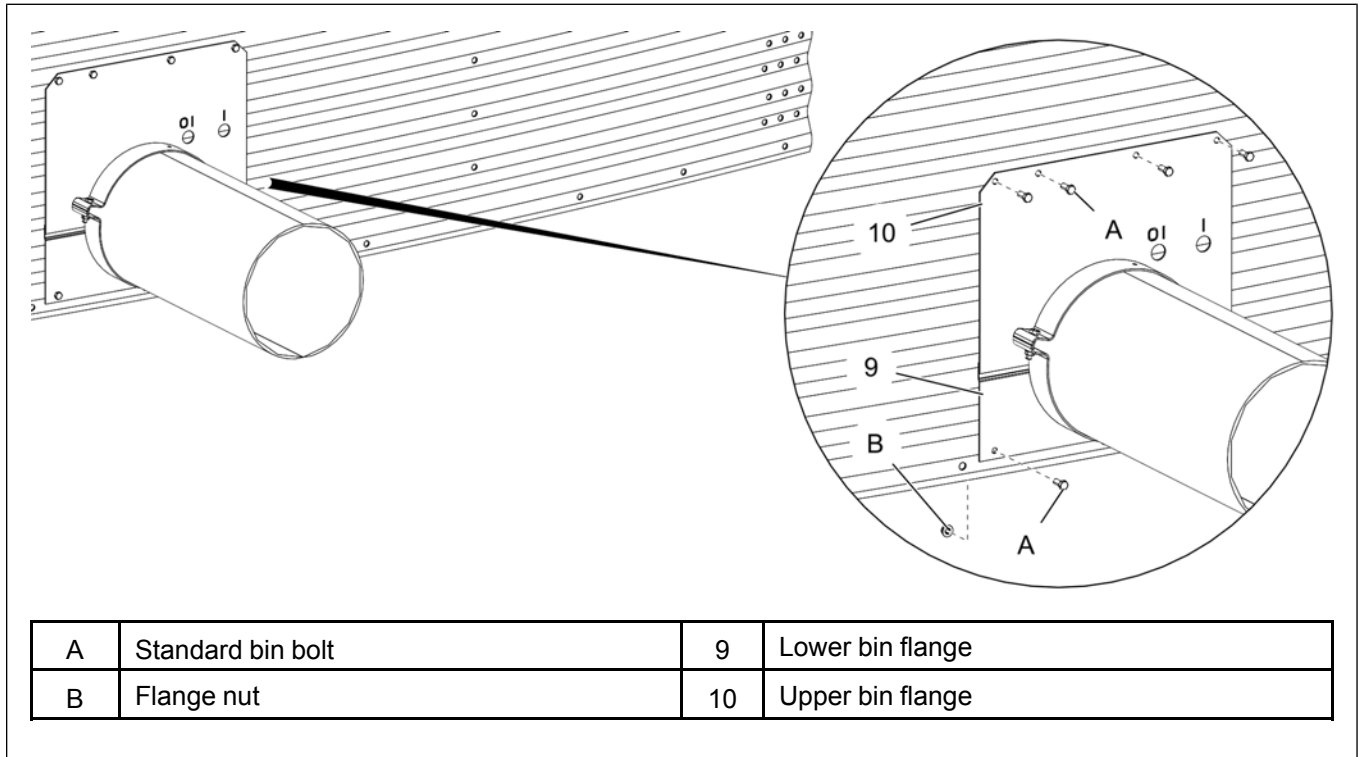


**NOTE:** Follow the steps from 1-4 to install the upper bin flange and lower bin flange to the opposite side of the bin.

**Figure 3-6** Installing the upper and lower bin flanges (opposite side)



**Figure 3-7** Secure the upper and lower bin flanges (opposite side)



## Intermediate Well Layout

Refer to the below intermediate well details for all the diameters.

Figure 3-8 Intermediate well layout

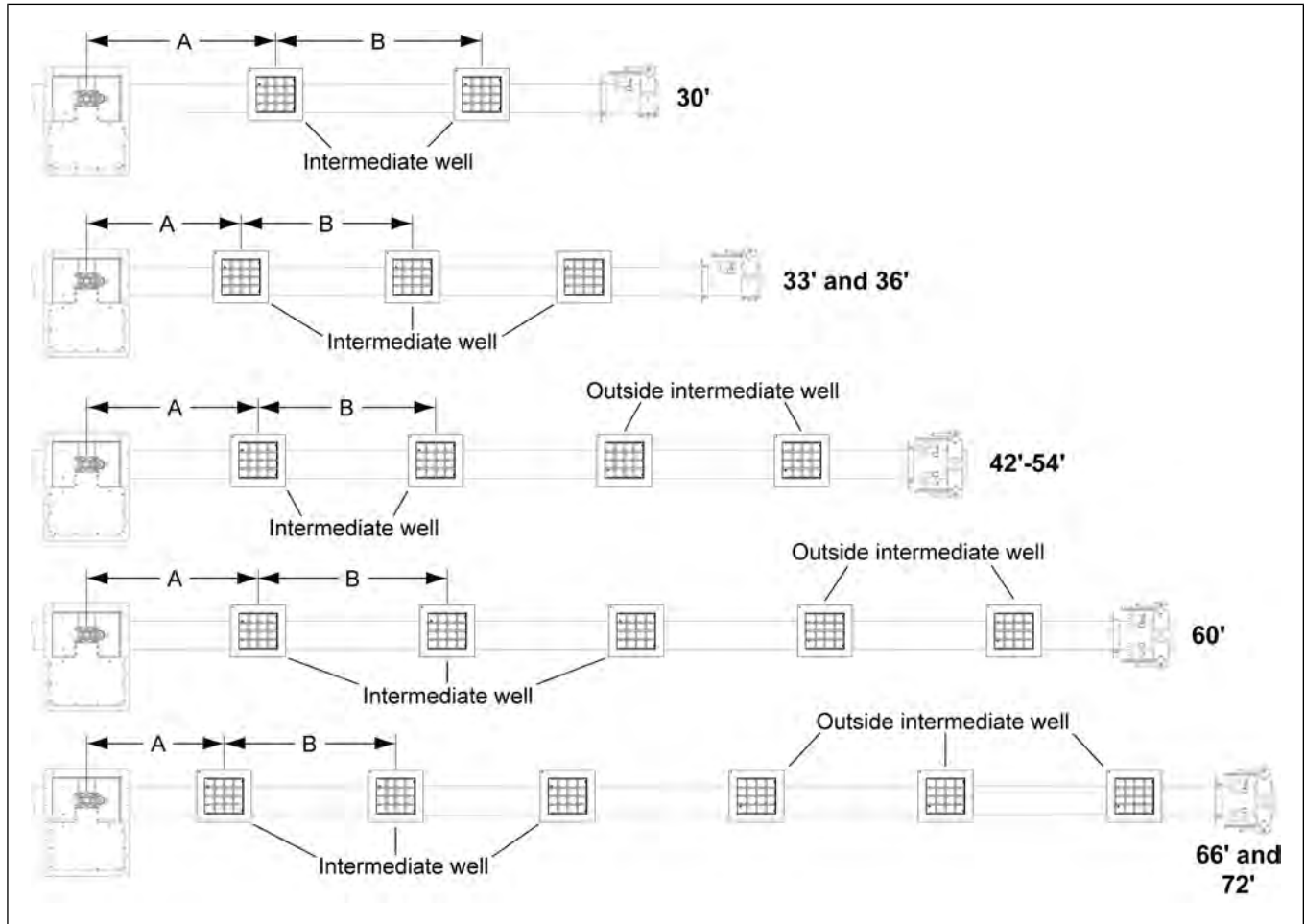


Table 3-1 Intermediate well dimensions

Bin diameter	# of intermediate wells	Distance between center of bin and first intermediate well (A)	Distance between intermediate wells (B)
30'	2	6' - 6"	72"
33'	3	4' - 6-1/4"	48"
36'	3	4' - 6"	60"
39'	3	5' - 4-1/4"	42"
42'	4	4' - 6"	54"
48'	4	5'	62"
54'	4	5'	66"
60'	5	5'	66"
66'	6	4'	60"
72'	6	4'	60"

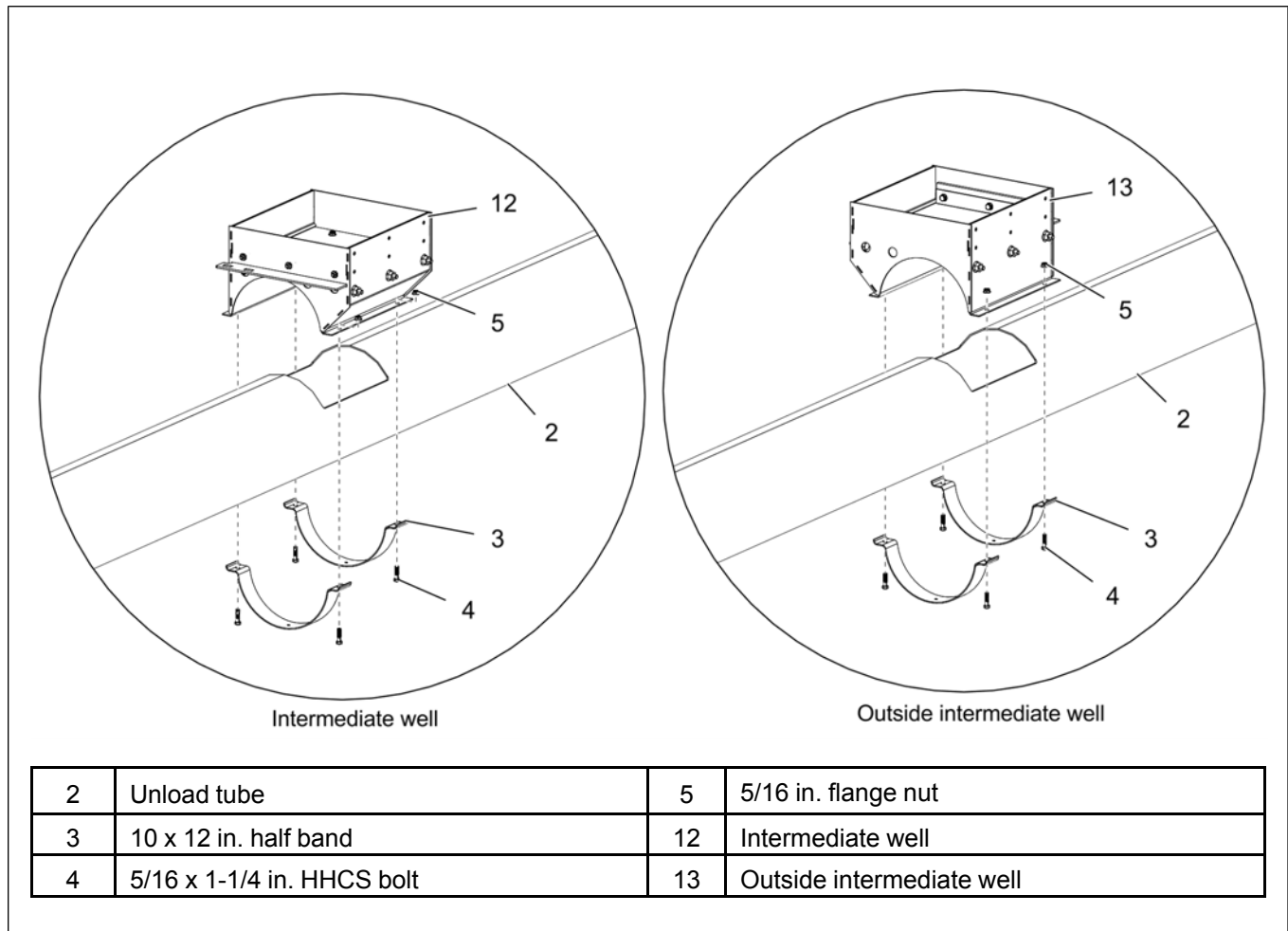
## Installing the Intermediate Well

1. Install the intermediate wells (12) to the unload tube (2) near the center well using half bands (3), 5/16 x 1-1/4 in. HHCS bolts (4) and 5/16 in. flange nuts (5).
2. Install the outside intermediate wells (13) to the unload tube (2) using half bands (3), 5/16 x 1-1/4 in. HHCS bolts (4) and 5/16 in. flange nuts (5).

### NOTE:

- a. The intermediate wells on the center well gate side should be installed with the gate opening in the same direction as the center well gate opening.
- b. The intermediate wells on the opposite side should be installed with the gate opening direction opposite to the center well gate opening.

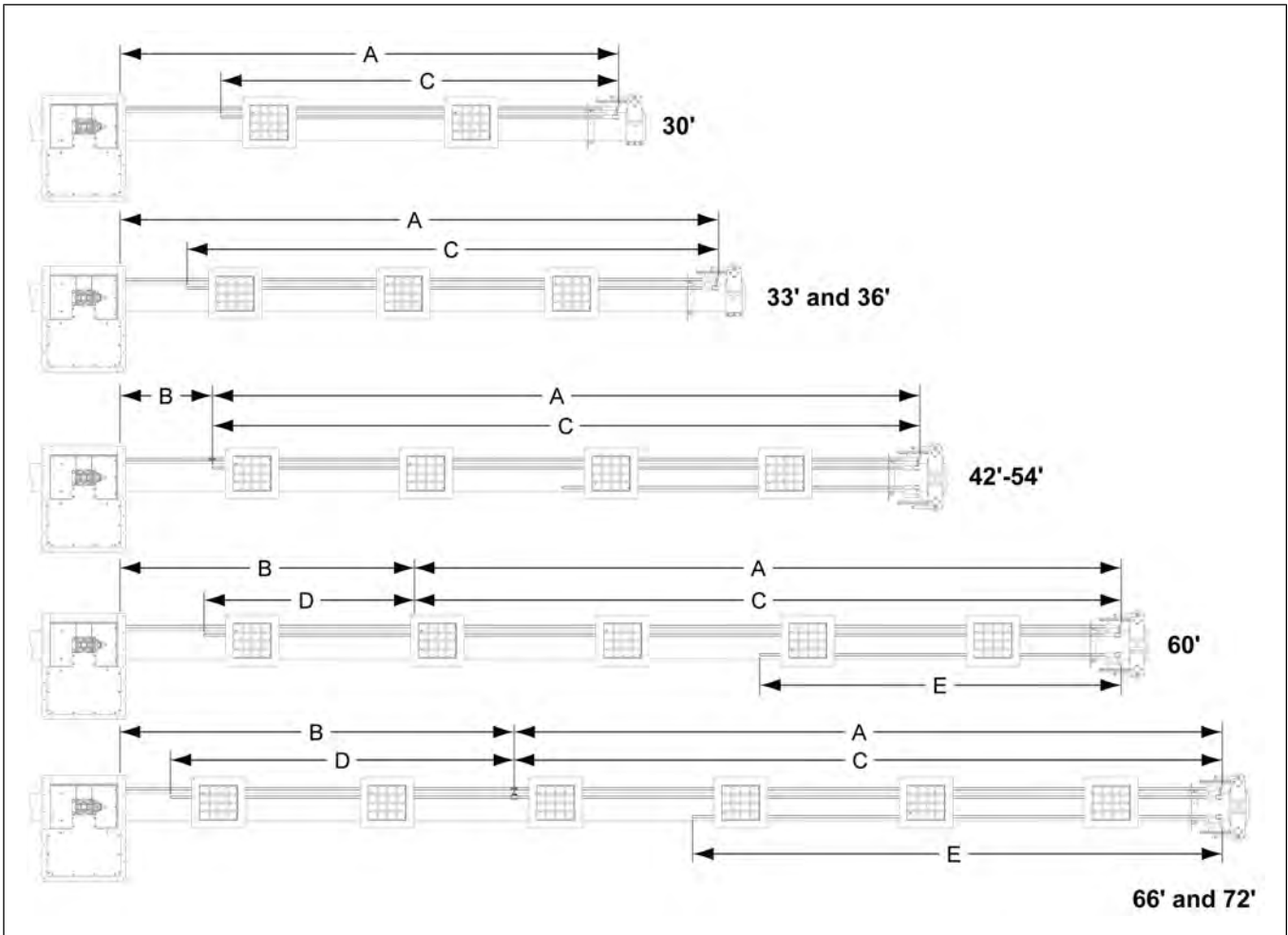
Figure 3-9 Installing the intermediate wells



# Control Rod Layout

Refer to the below control rods details for all the diameters.

Figure 3-10 Control rod layout dimensions



Bin diameter	# of intermediate wells	Center well control rod length (A)	Center well control rod extension length (B)	Intermediate well control rod length (C)	Intermediate well control rod extension length (D)	Outside intermediate well control rod length (E)
30'	2	14' - 9-7/8"	-	12' - 1/8"	-	-
33'	3	16' - 3-7/8"	-	14' - 6-1/8"	-	-
36'	3	17' - 9-11/16"	-	15' - 11-15/16"	-	-
39'	3	16' - 2-3/4"	-	13' - 4-15/16"	-	-
42'	4	20' - 9-1/2"	-	18' - 11-3/4"	-	9' - 11-3/4"
48'	4	21'	2' - 9-5/16"	21'	-	10' - 9-9/16"
54'	4	21'	5' - 9-3/16"	21'	3' - 5-7/16"	18' - 11-7/16"
60'	5	21'	8' - 9"	21'	6' - 5-1/4"	10' - 11-1/4"
66'	6	21'	11' - 8-13/16"	21'	10' - 5-1/16"	15' - 11-1/16"
72'	6	21'	14' - 8-5/8"	21'	13' - 4-7/8"	18' - 10-7/8"

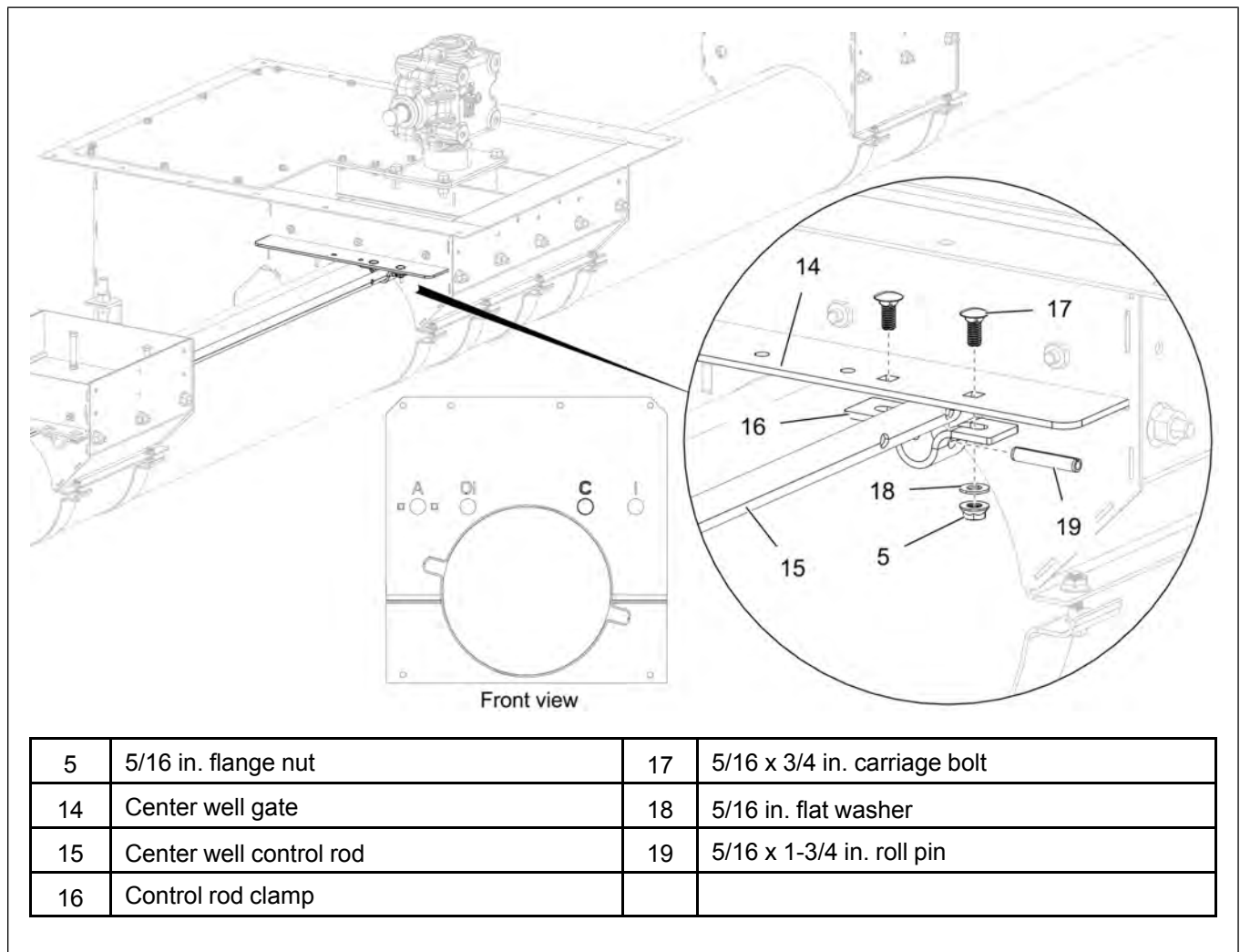
## Installing the Center Well Gate

### Before You Begin

Knock out the holes in the upper bin flange for the center and intermediate well control rods to pass through.

1. Slide the center well control rod (15) through the hole marked with a 'C' on the bin flange and through the intermediate wells until it reaches the center well gate (14).
2. Close the center well gate (14).
3. Align the center well control rod (15) between the square holes on the gate (14).
4. Attach the control rod clamp (16) to the control rod (15) with a 5/16 x 1-3/4 in. roll pin (19) aligning with the last hole in the control rod (15).
5. Secure the control rod clamp (16) to the center well gate (14) using 5/16 x 3/4 in. carriage bolts (17), 5/16 in. flat washers (18) and 5/16 in. flange nuts (5).

**Figure 3-11** Center well gate assembly



### After You Finish

Make sure the gate operates smoothly and closes completely. Make any necessary adjustments.

### Installing the Intermediate Well Gate

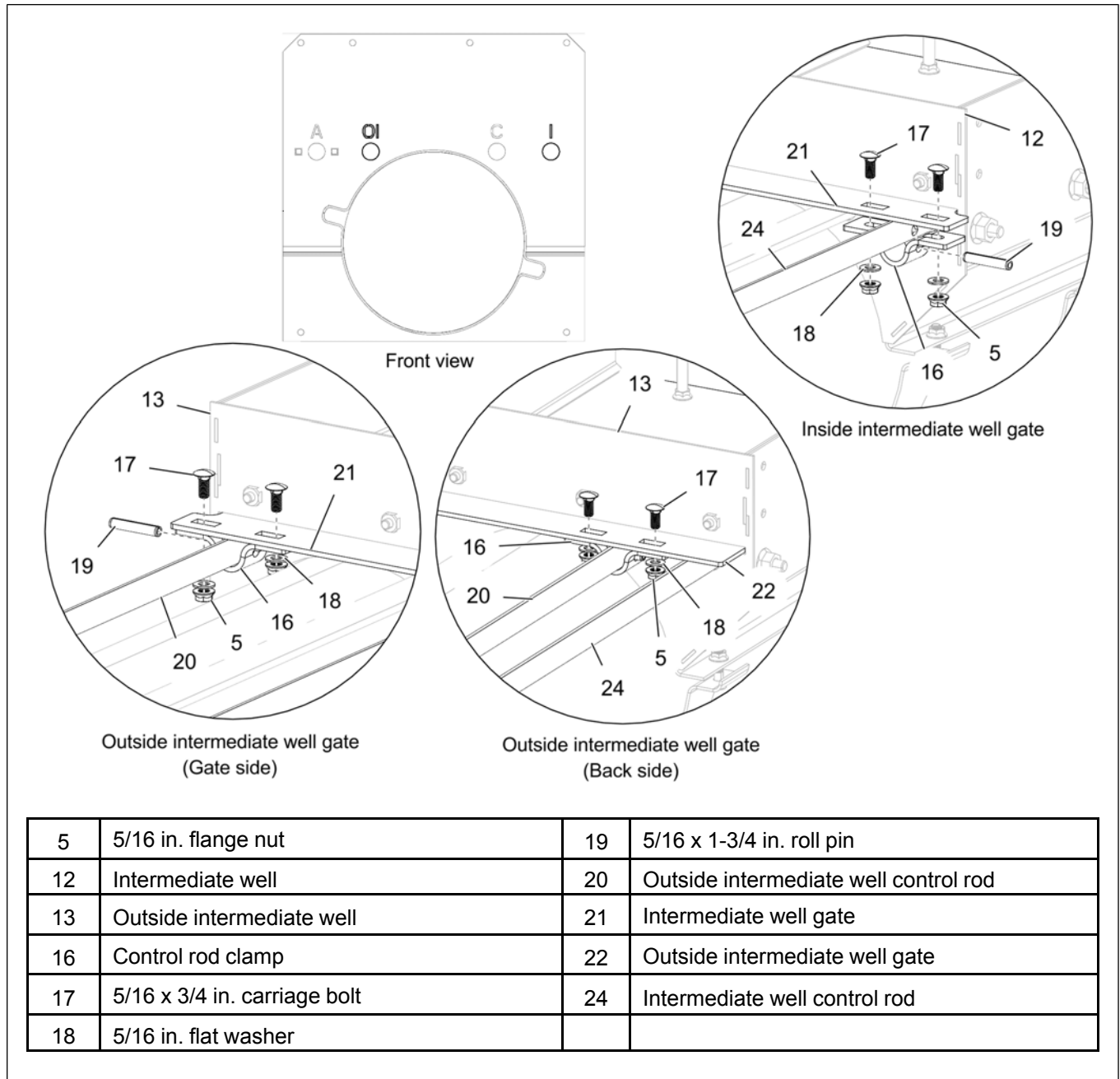
#### Before You Begin

Knock out the holes in the upper bin flange for the intermediate well control rods to pass through.

1. Slide the intermediate well control rod (24) through the holes marked with 'I' on the bin flange and through the intermediate wells until it reaches the last intermediate well (12) from the bin flange.
2. Slide the outside intermediate well control rod (20) through the hole marked with 'OI' on the bin flange and through the intermediate wells until it reaches last outside intermediate well (13) from the bin flange.
3. Close the intermediate well gates completely.
4. Align the intermediate well control rod (24) between the holes in the intermediate well gates (21) and attach the control rod clamps (16) to control rod (24) with 5/16 x 1-3/4 in. roll pin (19) through the clamps and holes in the control rod.
5. Secure the control rod clamps (16) to the gates (21) by using 5/16 x 3/4 in. carriage bolts (17), 5/16 in. flat washers (18) and 5/16 in. flange nuts (5).
6. Align the outside intermediate well control rod (20) between the holes on the outside intermediate well gates (22) and attach the control rod clamps (16) to the control rod (20) with 5/16 x 1-3/4 in. roll pin (19) through the clamps and the holes in the control rod.
7. Secure the control rod clamps (16) to the gates (22) by using 5/16 x 3/4 in. carriage bolts (17), 5/16 in. flat washers (18) and 5/16 in. flange nuts (5).

**NOTE:** *Similarly install the intermediate control rods and outside intermediate control rods on opposite side of the bin.*

Figure 3-12 Intermediate well gate assembly



**After You Finish**

Make sure gates operate smoothly and close completely. Make any necessary adjustments.



## Installing the Auxiliary Intermediate Well (Optional)

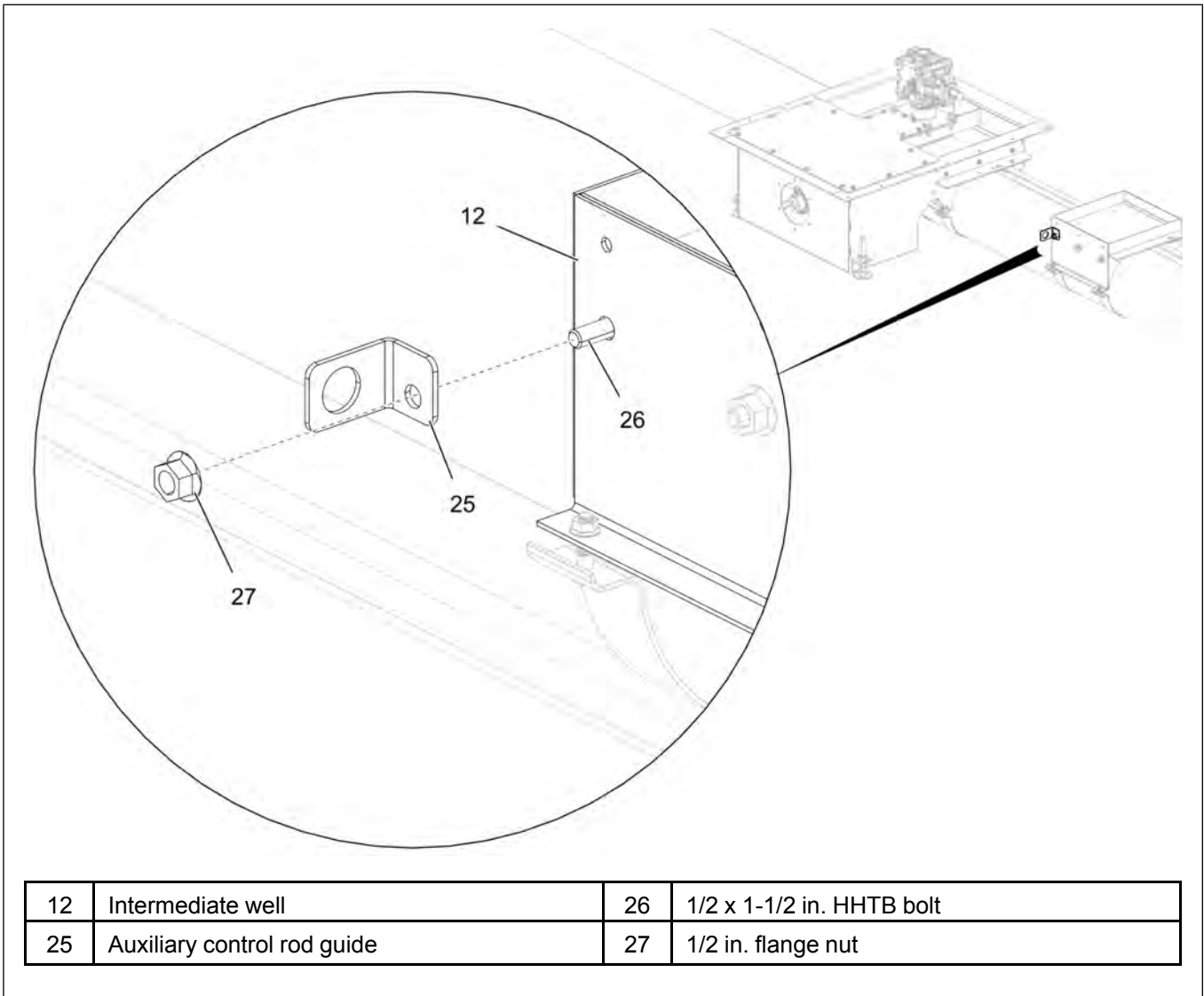
### What You Should Know

If the center well becomes plugged during gravity unloading, this option allows the bin to still be unloaded until the plugged center well can be addressed. This control option allows the end user to independently control the intermediate closest to the center well

1. Install the auxiliary control rod guides (25) to all intermediate wells (12) using 1/2 x 1-1/2 in. HHTB bolts (26) and 1/2 in. flange nuts (27).

**NOTE:** *The control rod guide must mount to the intermediate well as shown for proper rod alignment to gate and wall flange.*

Figure 3-13 Installing the auxiliary rod guide to intermediate well

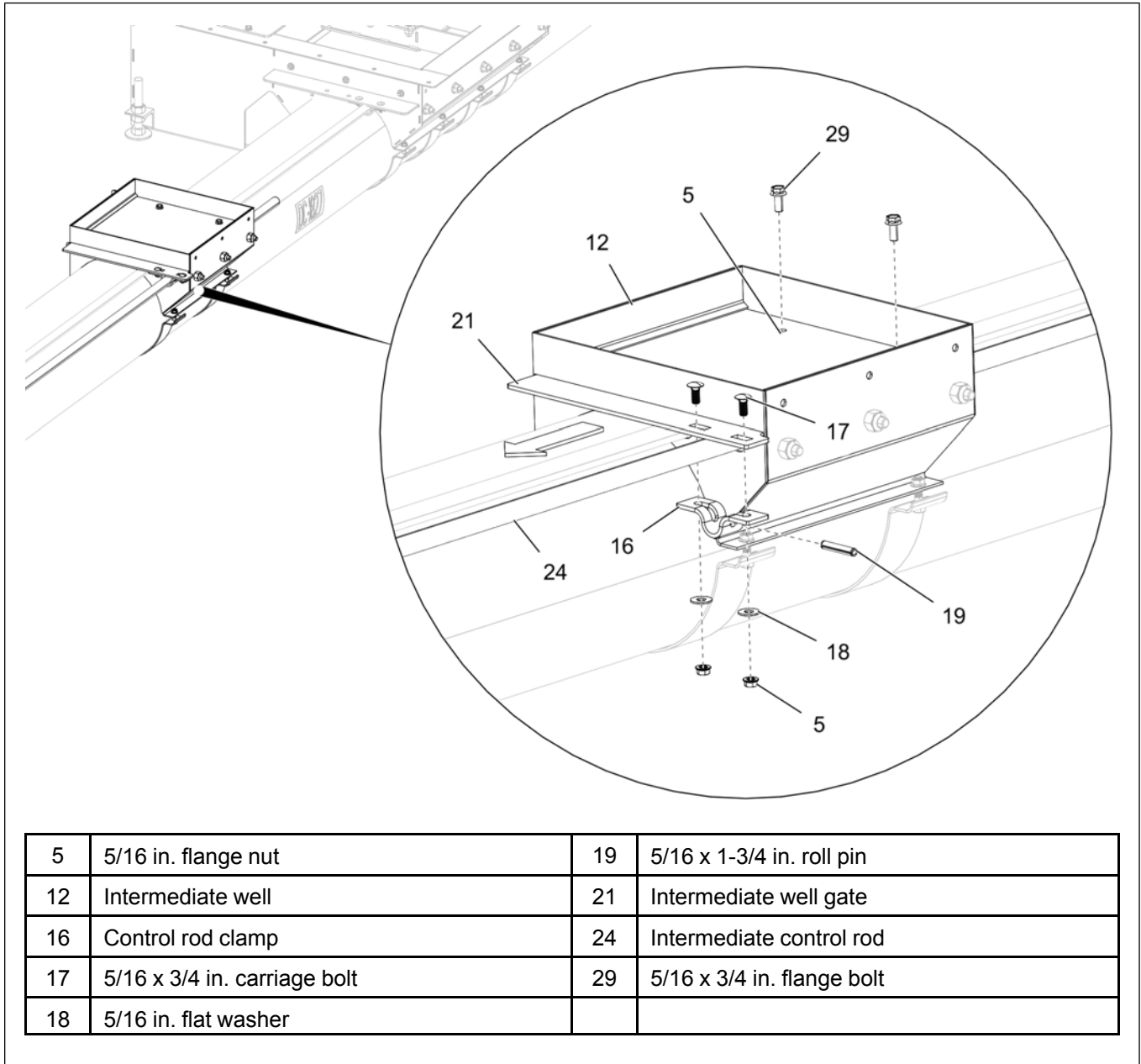




- Slide and remove the intermediate gate (21) from the intermediate well (12) next to the center well.

**NOTE:** Make sure to partially pull the intermediate gate (21) out to allow gap for removing the gate clamp (16), pin (19), bolts (29), washers (18) and nuts (5) at the outside of the intermediate well to remove the intermediate gate in a 10 in. sweep.

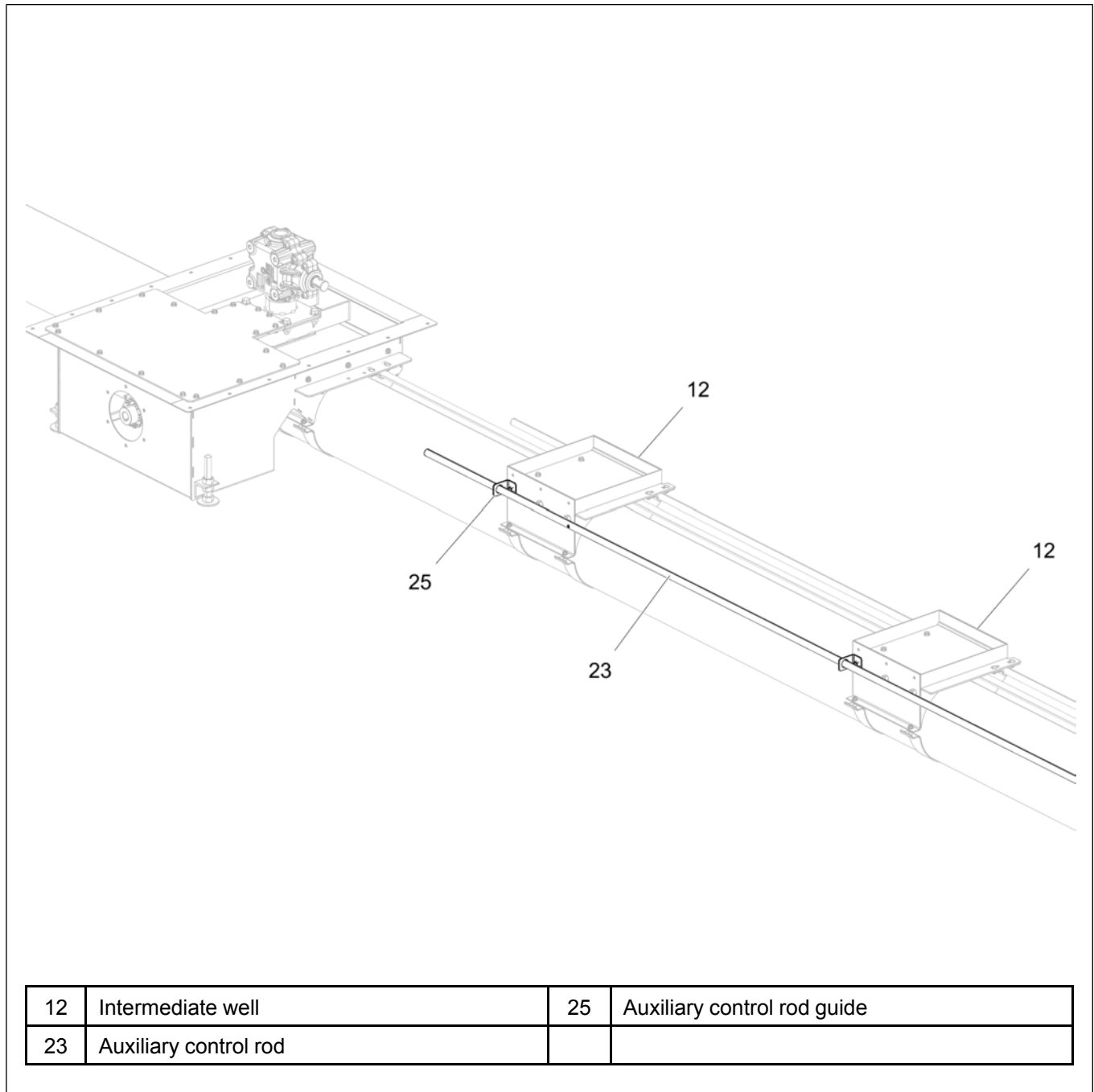
**Figure 3-14** Removing the intermediate gate (10 in. sweep)



## Chapter 3: Installation

- Slide the auxiliary control rod (23) through the bin flange and auxiliary well control rod guide brackets (25) in the intermediate wells (12).

**Figure 3-15** Sliding the auxiliary control rod through rod guide bracket



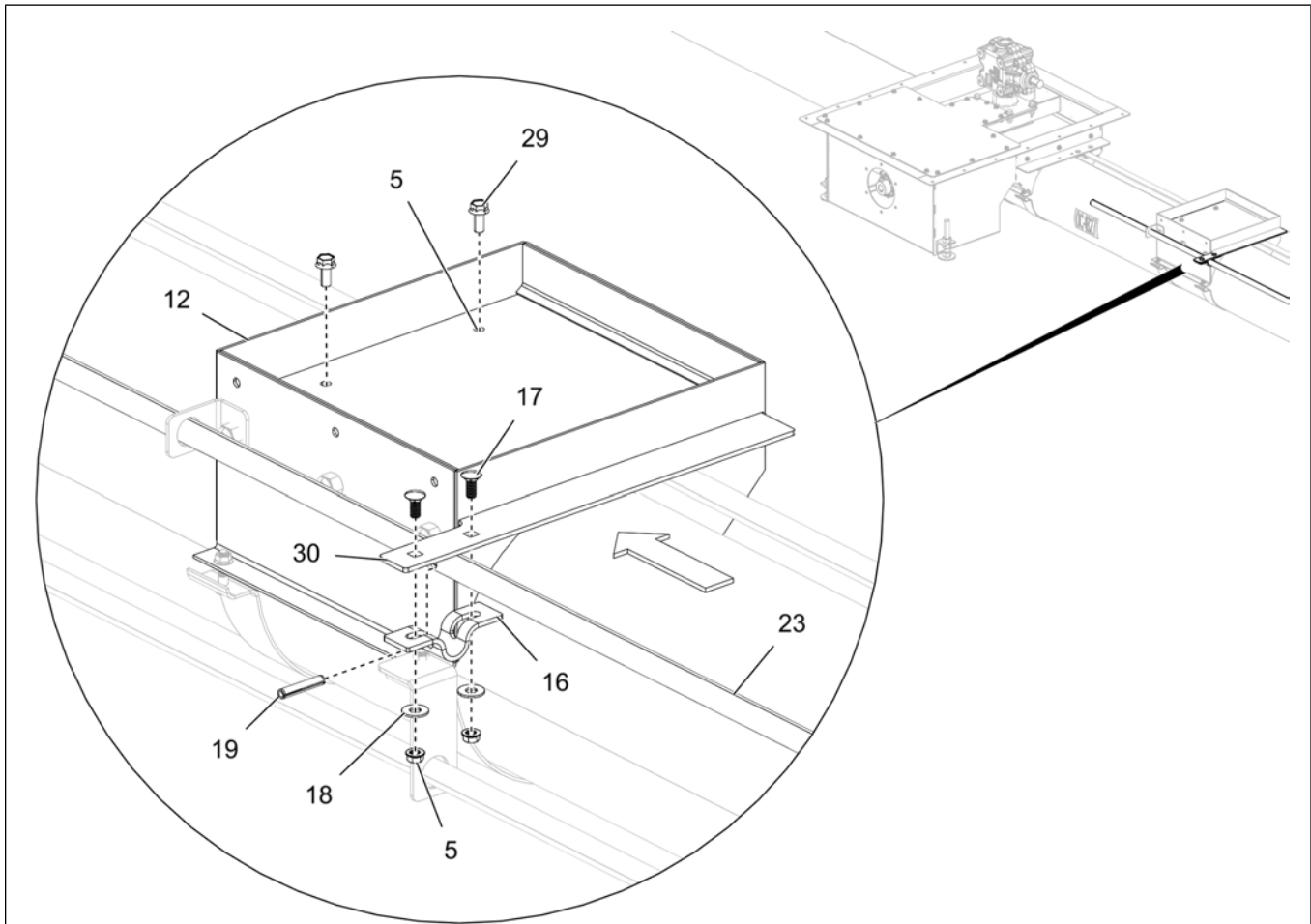
- Install the auxiliary well gate (30) using the 5/16 x 3/4 in. flange bolts (29) and 5/16 in. flange nuts (5). Install the gate clamp (16), 5/16 x 3/4 in. carriage bolts (17), 5/16 in. flat washers (18), 5/16 in. flange nuts (5) and 5/16 x 1-3/4 in. roll pin (19) at the outside of the intermediate well (12).

**NOTE:**

- Make sure to provide gap in the intermediate well (12) to install the bolts (29) and serrated flange nuts (5) in the auxiliary gate (30) before closing.
- Make sure to install the gate clamp (16), carriage bolts (17), flat washers (18), flange nuts (5) and pin (19) to the auxiliary gate (30) with the auxiliary control rod (23) at the outside of the intermediate well (12).

**IMPORTANT:** Carriage bolts (17) must be installed from top down as shown, if not, they will interfere with the flooring and will not open.

Figure 3-16 Installing the auxiliary intermediate gate

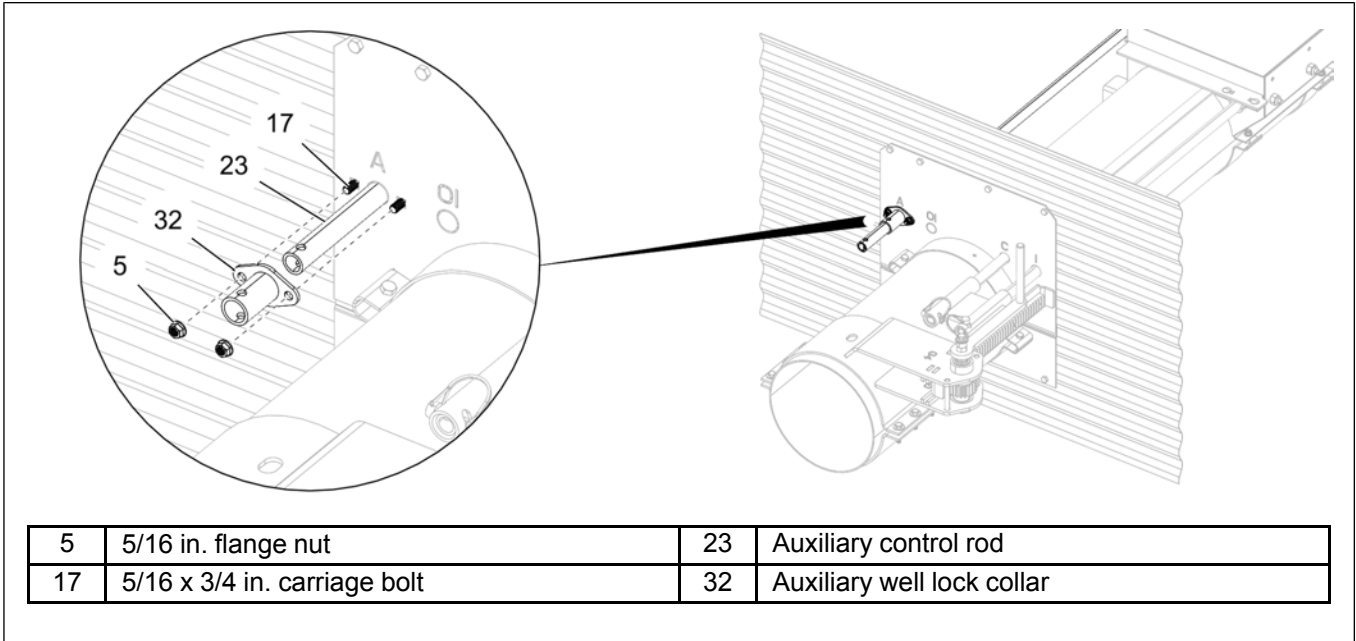


5	5/16 in. flange nut	19	5/16 x 1-3/4 in. roll pin
12	Intermediate well	23	Auxiliary control rod
16	Control rod clamp	29	5/16 x 3/4 in. flange bolt
17	5/16 x 3/4 in. carriage bolt	30	Auxiliary well gate
18	5/16 in. flat washer		

## Chapter 3: Installation

5. Insert the auxiliary well lock collar (32) onto the auxiliary control rod (23) and install to the bin flange using 5/16 x 3/4 in. carriage bolts (17) and 5/16 in. flange nuts (5).

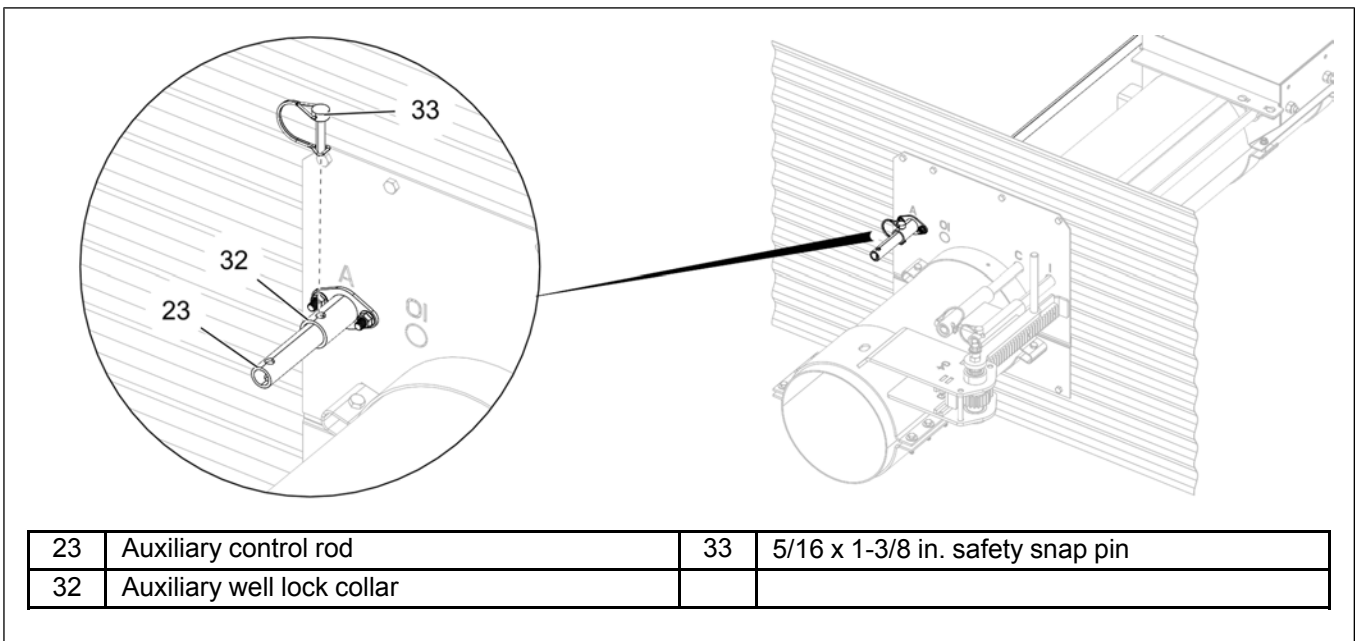
**Figure 3-17** Installing the auxiliary well lock collar to bin flange



6. Insert the lock pin (33) through the auxiliary lock collar (32) and auxiliary control rod (23).

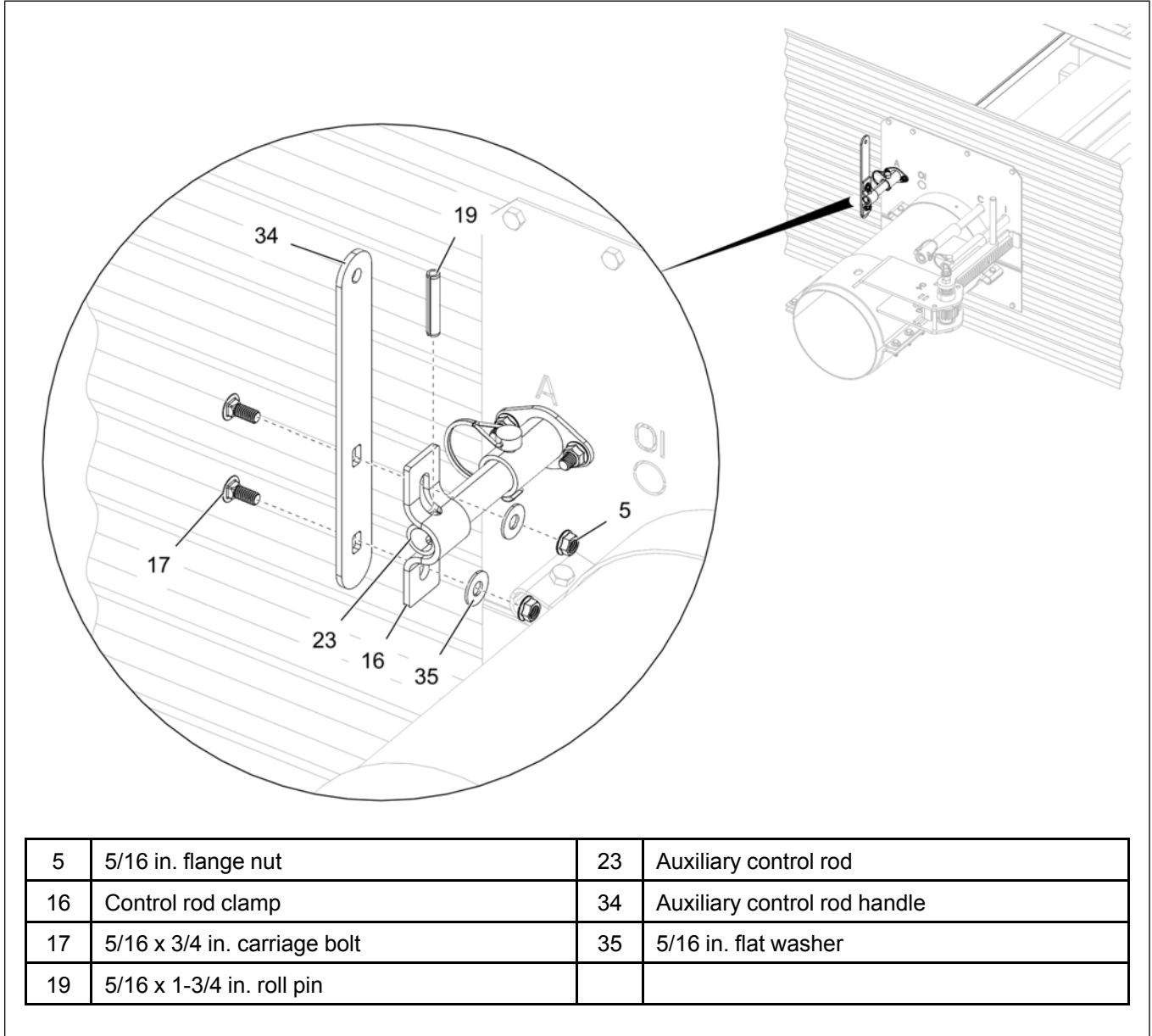
**NOTE:** Make sure the auxiliary well gate is completely closed, drill a hole in the auxiliary control rod using the auxiliary lock collar as drilling guide to insert the lock pin.

**Figure 3-18** Installing the lock pin



7. Install the auxiliary control rod handle (34) to the auxiliary control rod (23) using control rod clamp (16), 5/16 x 3/4 in. carriage bolts (17), 5/16 in. flat washers (35), 5/16 in. flange nuts (5) and 5/16 x 1-3/4 in. roll pin (19).

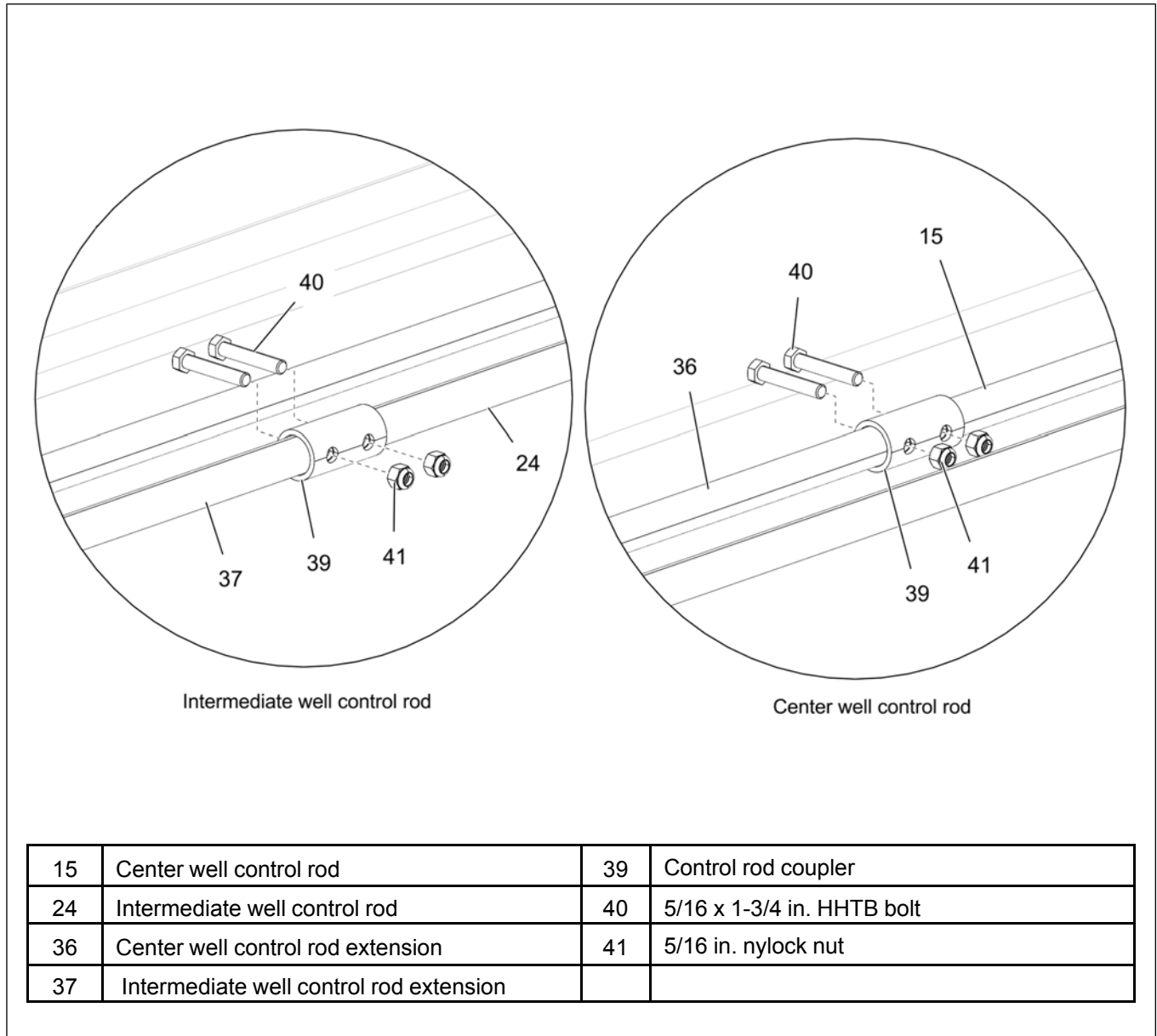
Figure 3-19 Installing the auxiliary control lever



## Connecting the Control Rods

1. Install the center well control rod extension (36) to the center well control rod (15) using the control rod coupler (39), 5/16 x 1-3/4 in. HHTB bolts (40) and 5/16 in. nylock nuts (41).
2. Install the intermediate well control rod extension (37) to the intermediate well control rod (24) using the control rod coupler (39), 5/16 x 1-3/4 in. HHTB bolts (40) and 5/16 in. nylock nuts (41).

Figure 3-20 Connecting the control rods



## Installing the Single Rack and Pinion (30 ft - 39 ft)

**NOTE:** The single rack and pinion can control the center well and intermediate well control rods. Install this single rack and pinion to the center well gate opening side for 30 ft. to 39 ft. diameter bins.

1. Make sure all gates are fully closed.
2. Slide the rack and pinion (47 and 120) over the control rods (15 and 24).

**NOTE:** Make sure rack and pinion is fully extended towards the bin wall and resting on the unload tube (2).

3. Align the holes in the control rods with the holes in the rack and pinion tubes.
4. For 10 in. unload tube, insert the snap-on pins (33) through the rack and pinion tubes and the control rods.
5. For 8 in. and 12 in. unload tubes, insert the 5/16 x 1-3/4 in. HHTB bolts (40) and 5/16 in. nylock nuts (41) through the rack and pinion tubes and the control rods.

**Figure 3-21** Installing the rack and pinion - 10 in. (gate opening side)

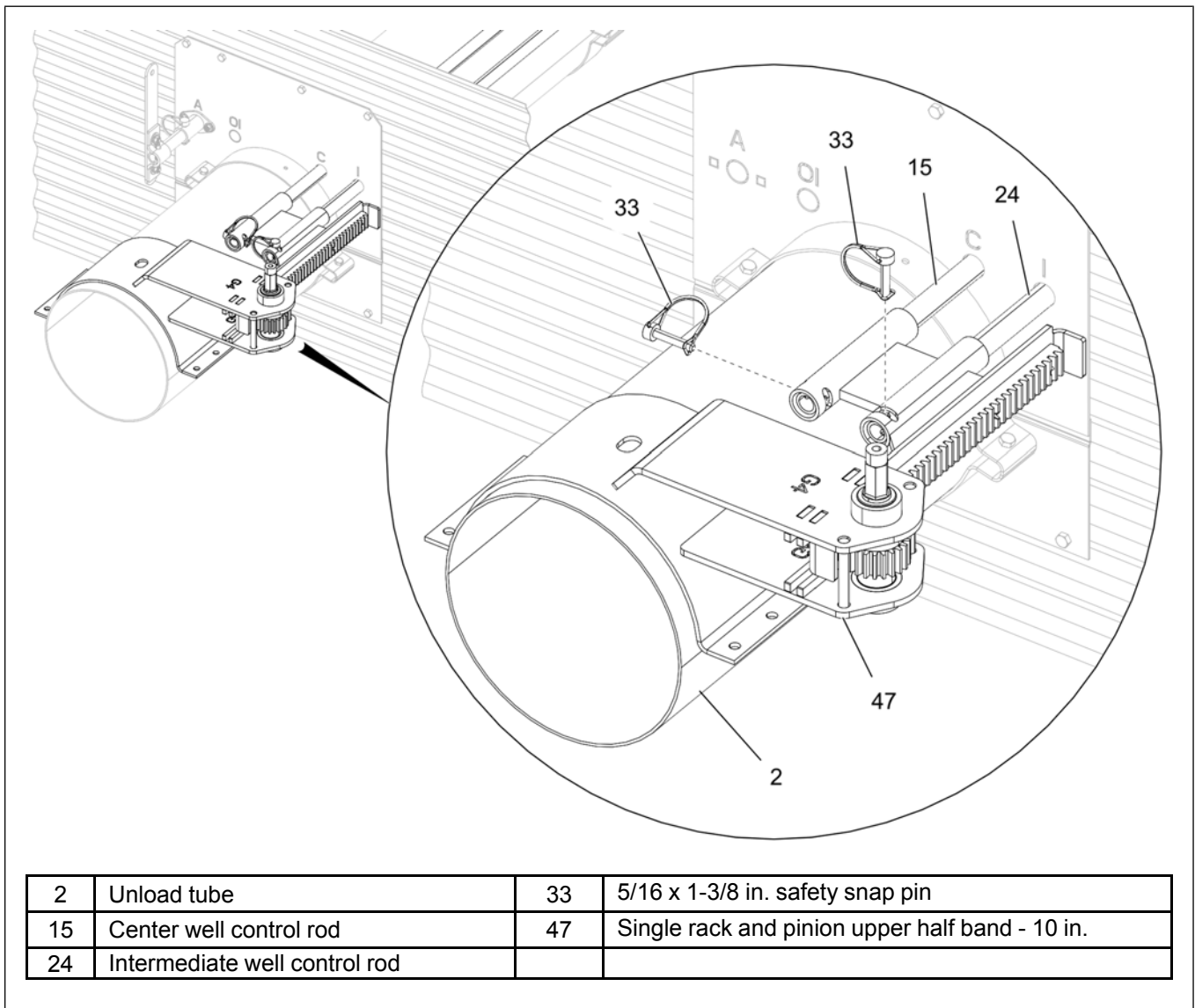
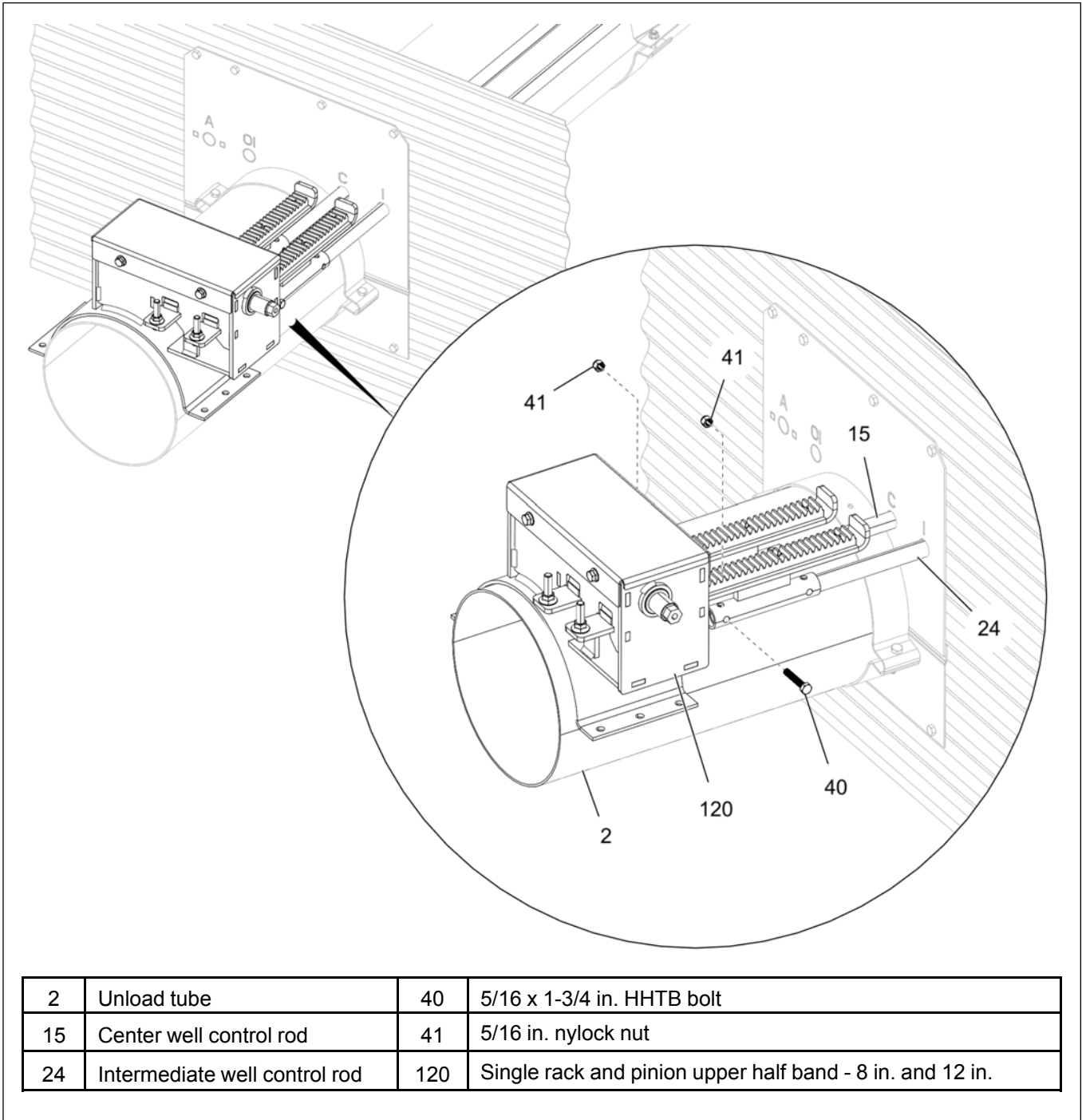




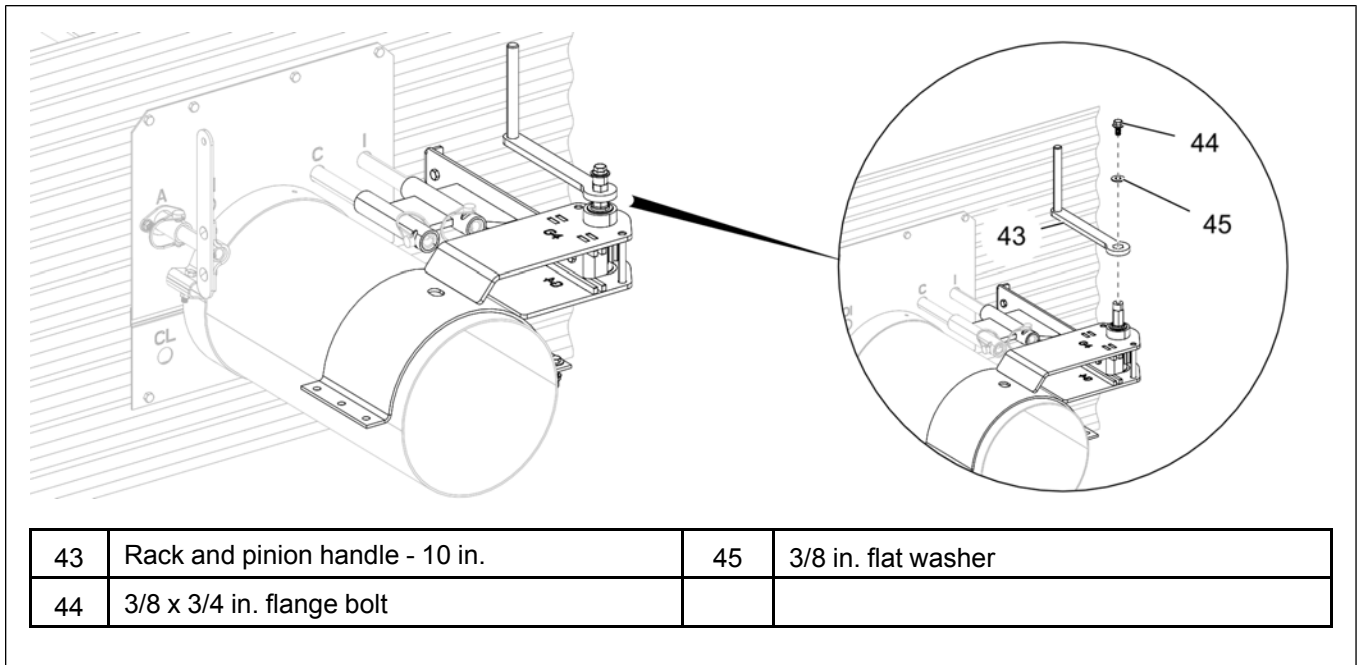
Figure 3-22 Installing the rack and pinion - 8 in. and 12 in. (gate opening side)



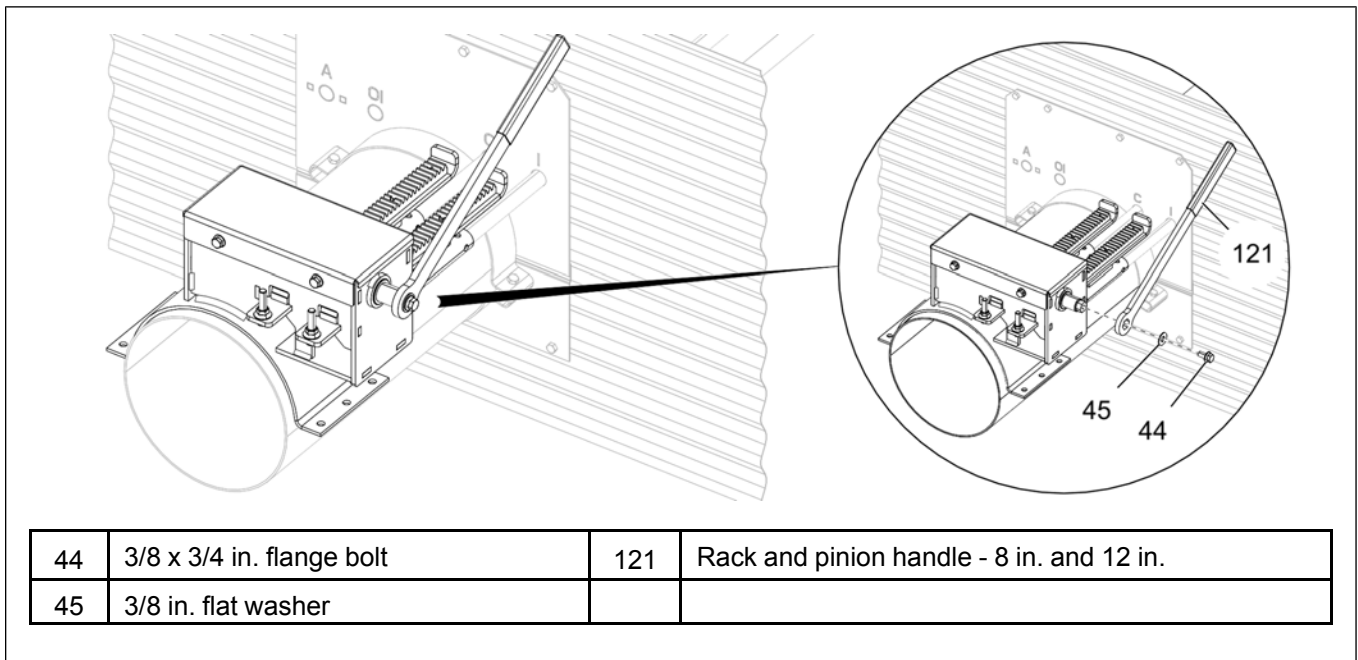


6. Slide the handle (43 and 121) over the shaft on the rack and pinion and install with 3/8 x 3/4 in. flange bolt (44) and 3/8 in. flat washer (45).

**Figure 3-23** *Installing the handle to rack and pinion - 10 in. (gate opening side)*



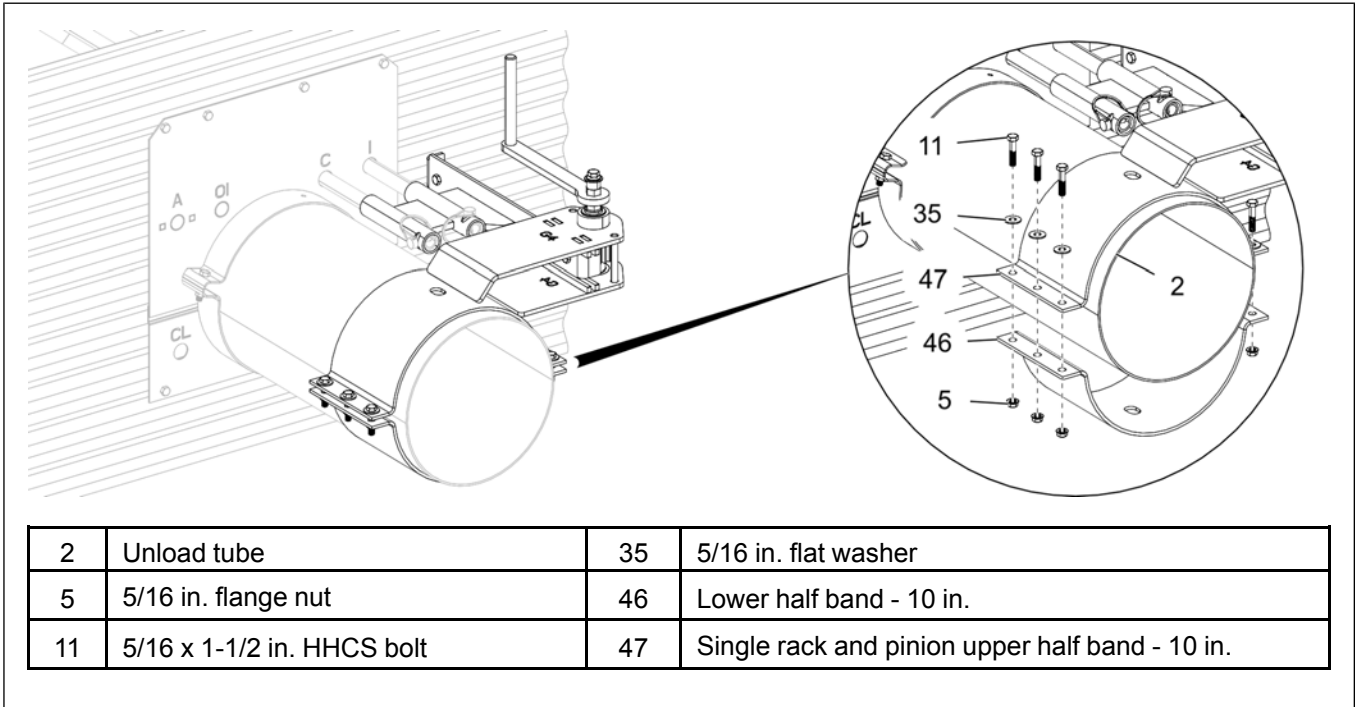
**Figure 3-24** *Installing the handle to rack and pinion - 8 in. and 12 in. (gate opening side)*



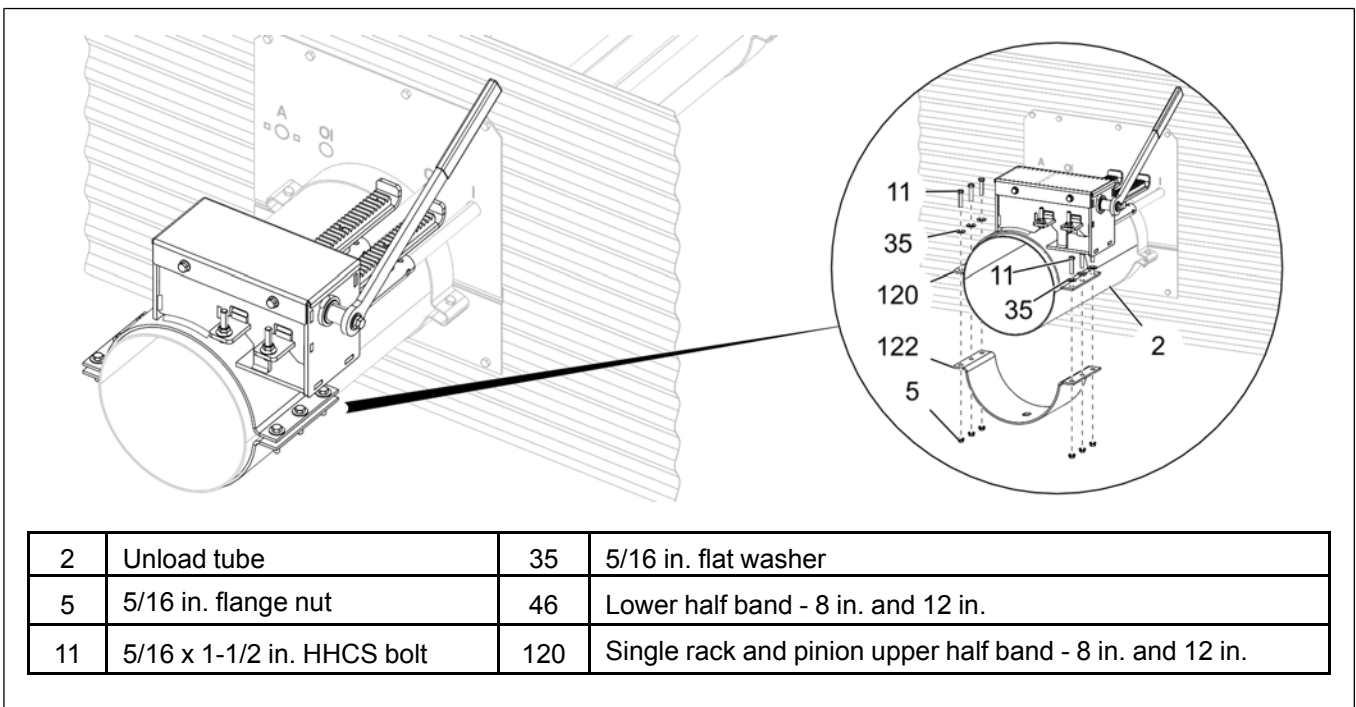
## Chapter 3: Installation

7. With rack and pinion fully extended towards the bin wall, attach the lower half band (46 and 122) to the rack and pinion (47 and 120) and install to the unload tube (2) with 5/16 x 1-1/2 in. HHCS bolts (11), 5/16 in. flat washers (35) and 5/16 in. flange nuts (5).

**Figure 3-25** Installing the lower half band to rack and pinion - 10 in. (gate opening side)

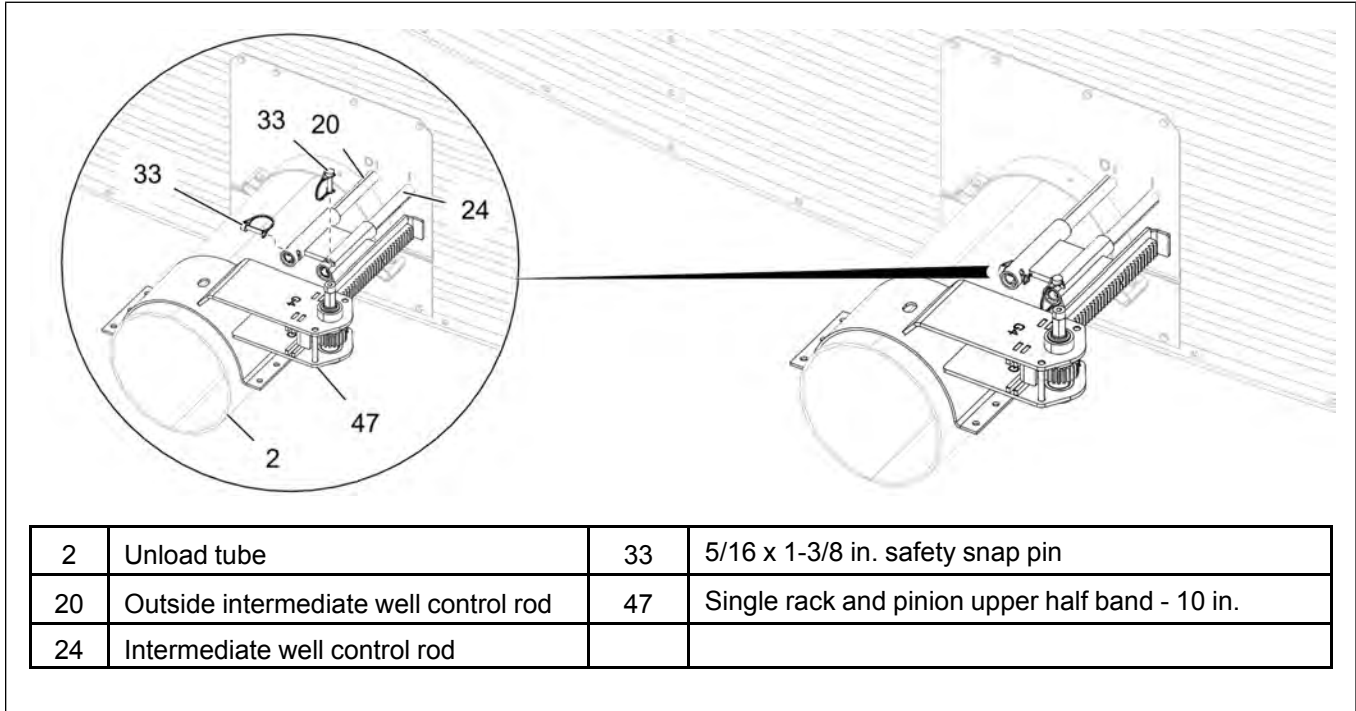


**Figure 3-26** Installing the lower half band to rack and pinion - 8 in. and 12 in. (gate opening side)

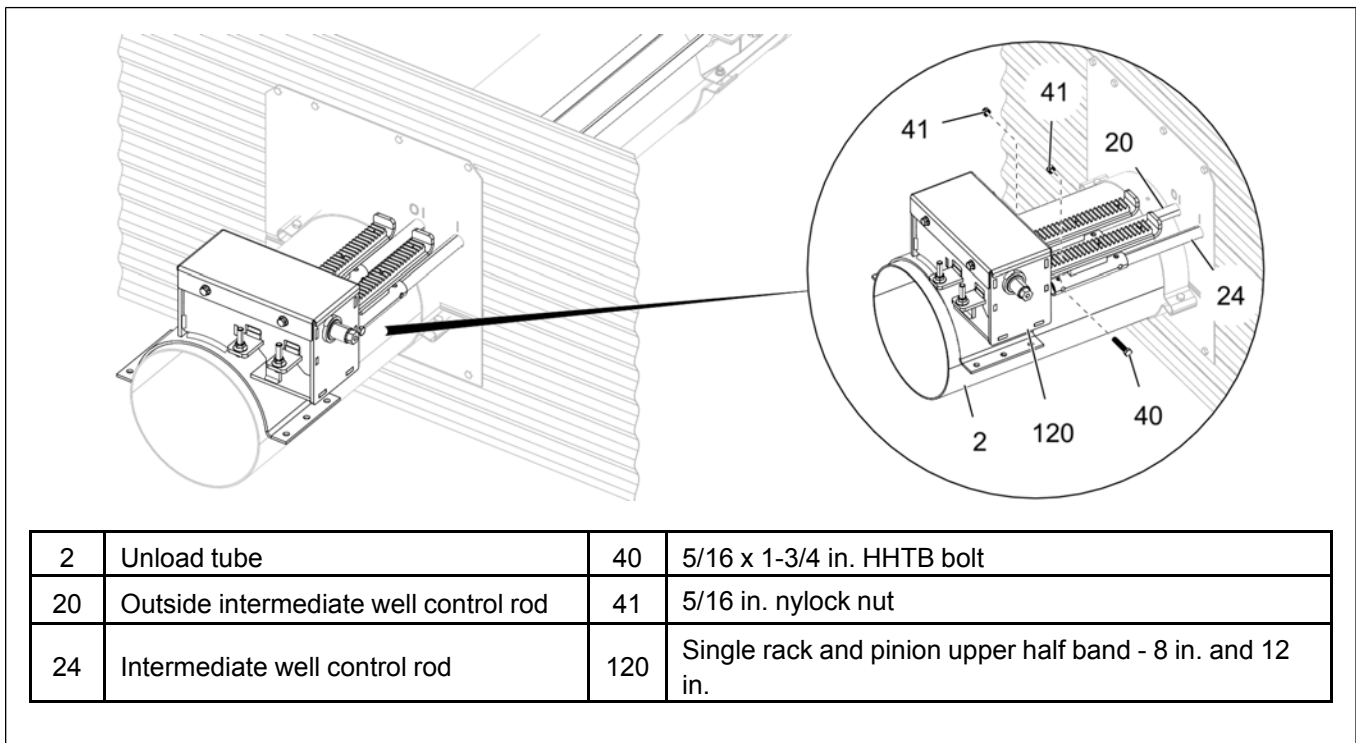


**NOTE:** The single rack and pinion is also installed on the opposite side of the bin for all the diameters. Follow the steps 1-6 to install the single rack and pinion for the opposite side of the bin.

**Figure 3-27** Installing the rack and pinion - 10 in. (opposite side)

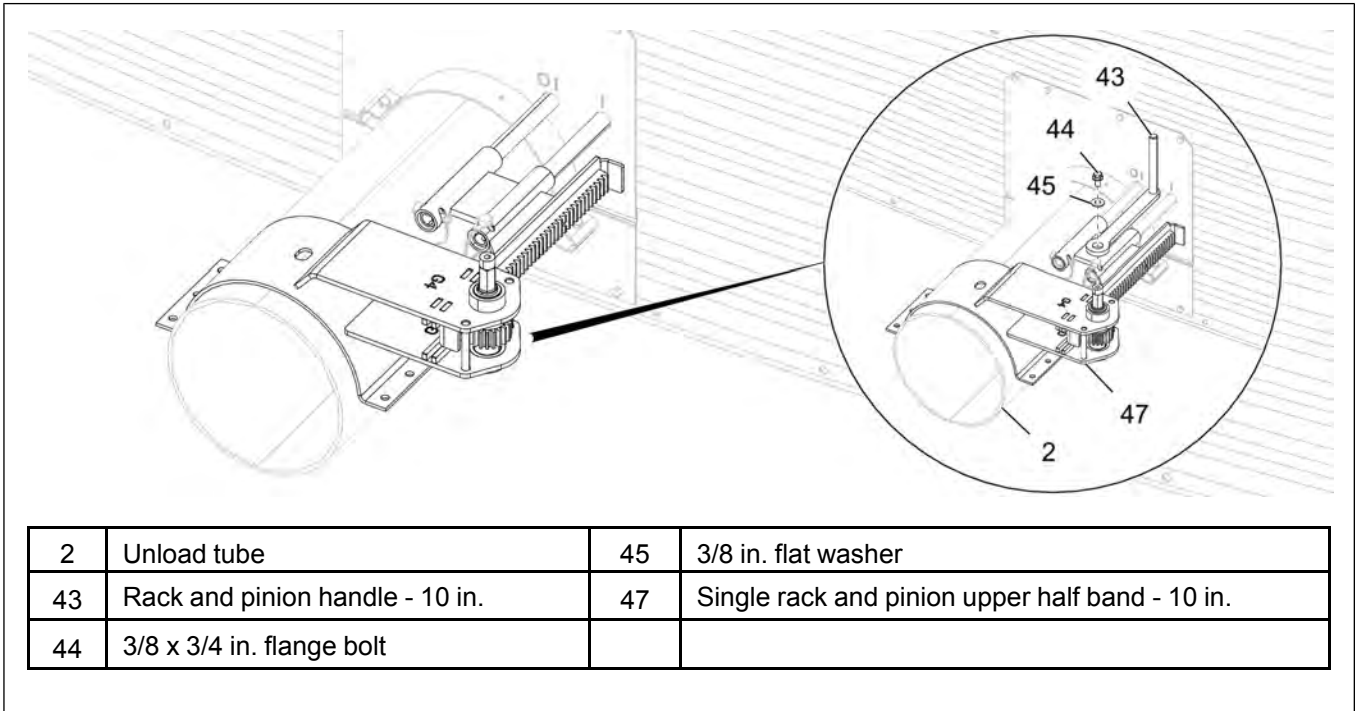


**Figure 3-28** Installing the rack and pinion - 8 in. and 12 in. (opposite side)



## Chapter 3: Installation

**Figure 3-29** Installing the handle to rack and pinion - 10 in. (opposite side)



**Figure 3-30** Installing the handle to rack and pinion - 8 in and 12 in. (opposite side)

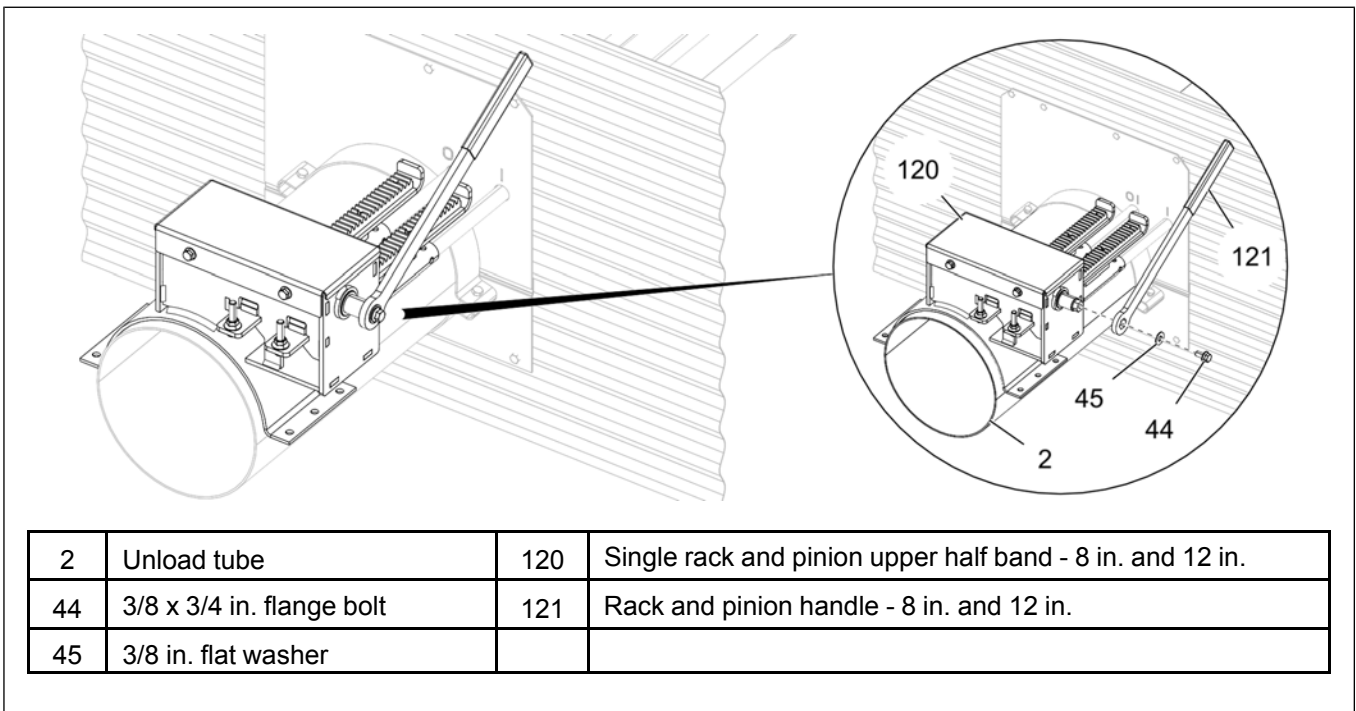




Figure 3-31 Installing the lower half band to rack and pinion - 10 in. (opposite side)

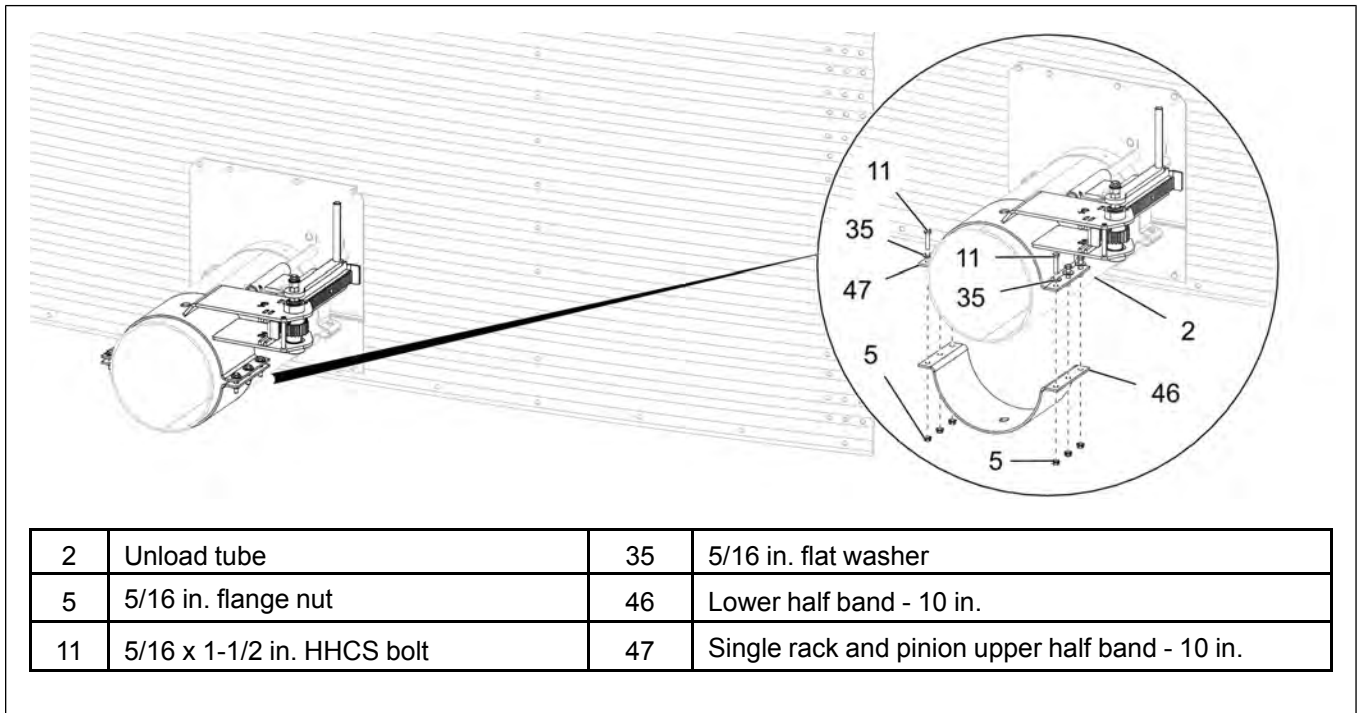
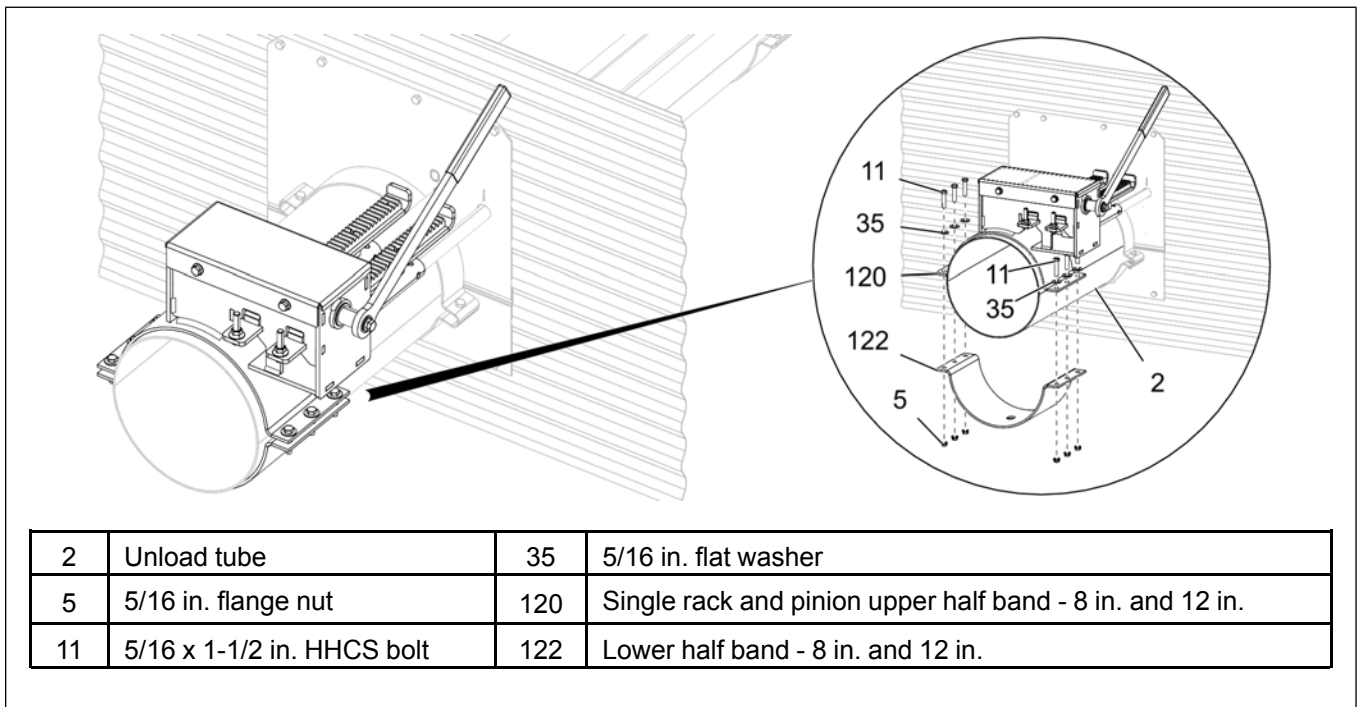


Figure 3-32 Installing the lower half band to rack and pinion - 8 in. and 12 in. (opposite side)



## Installing the Double Rack and Pinion (42 ft - 72 ft)

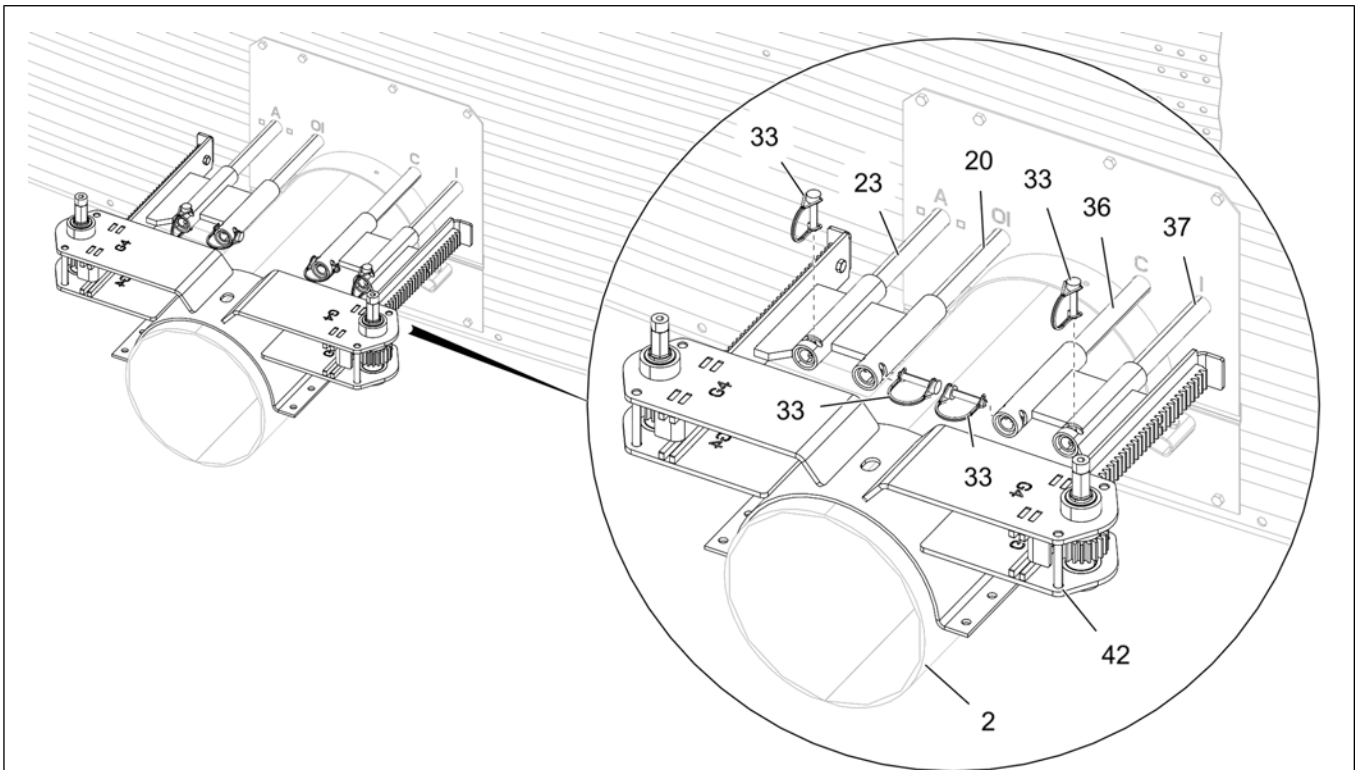
**NOTE:** The double rack and pinion can control the center well, intermediate well, outside intermediate well and auxiliary well control rods. Install the double rack and pinion on the center well gate opening side for 42 ft. to 72 ft. diameter bins.

1. Make sure all gates are fully closed.
2. Slide the rack and pinion (42 and 123) over the control rods (20, 23, 36 and 37).

**NOTE:** Make sure rack and pinion is fully extended toward bin wall and resting on the unload tube (2).

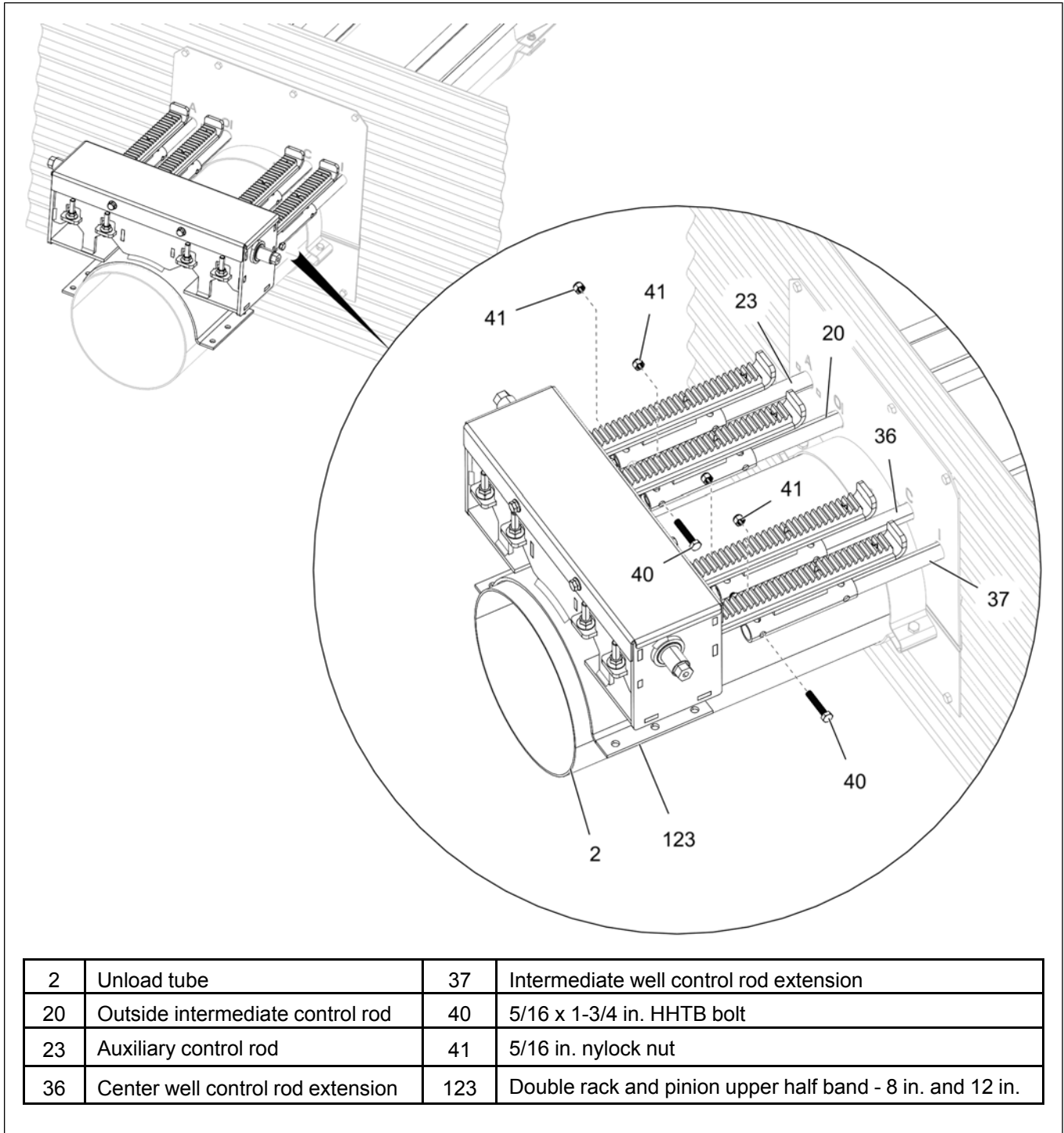
3. Align the holes in the control rods with the holes in the rack and pinion tubes.
4. For 10 in. unload tube, insert the snap-on pins (33) through the rack and pinion tubes and the control rods.
5. For 8 in. and 12 in. unload tubes, insert the 5/16 x 1-3/4 in. HHTB bolts (40) and 5/16 in. nylock nuts (41) through the rack and pinion tubes and the control rods.

**Figure 3-33** Installing the double rack and pinion - 10 in.



2	Unload tube	36	Center well control rod extension
20	Outside intermediate control rod	37	Intermediate well control rod extension
23	Auxiliary control rod	42	Double rack and pinion upper half band - 10 in.
33	5/16 x 1-3/8 in. safety snap pin		

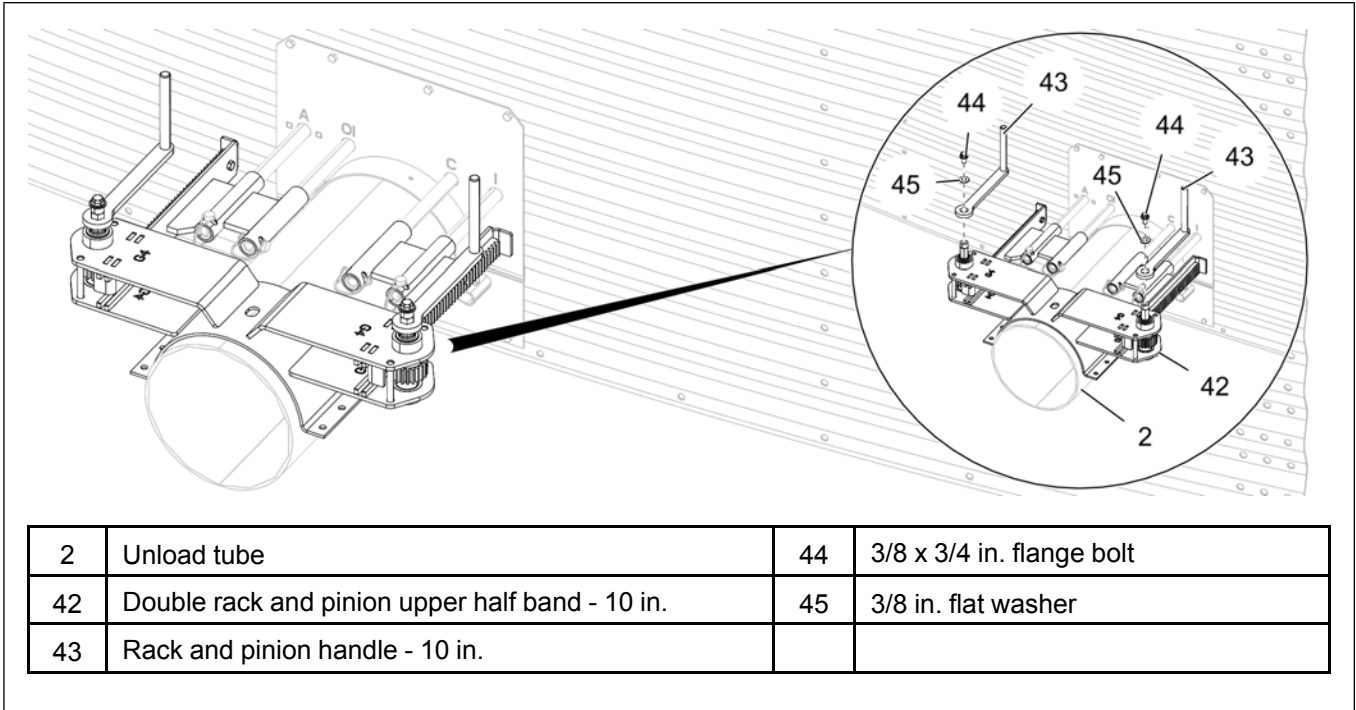
Figure 3-34 Installing the double rack and pinion - 8 in. and 12 in.



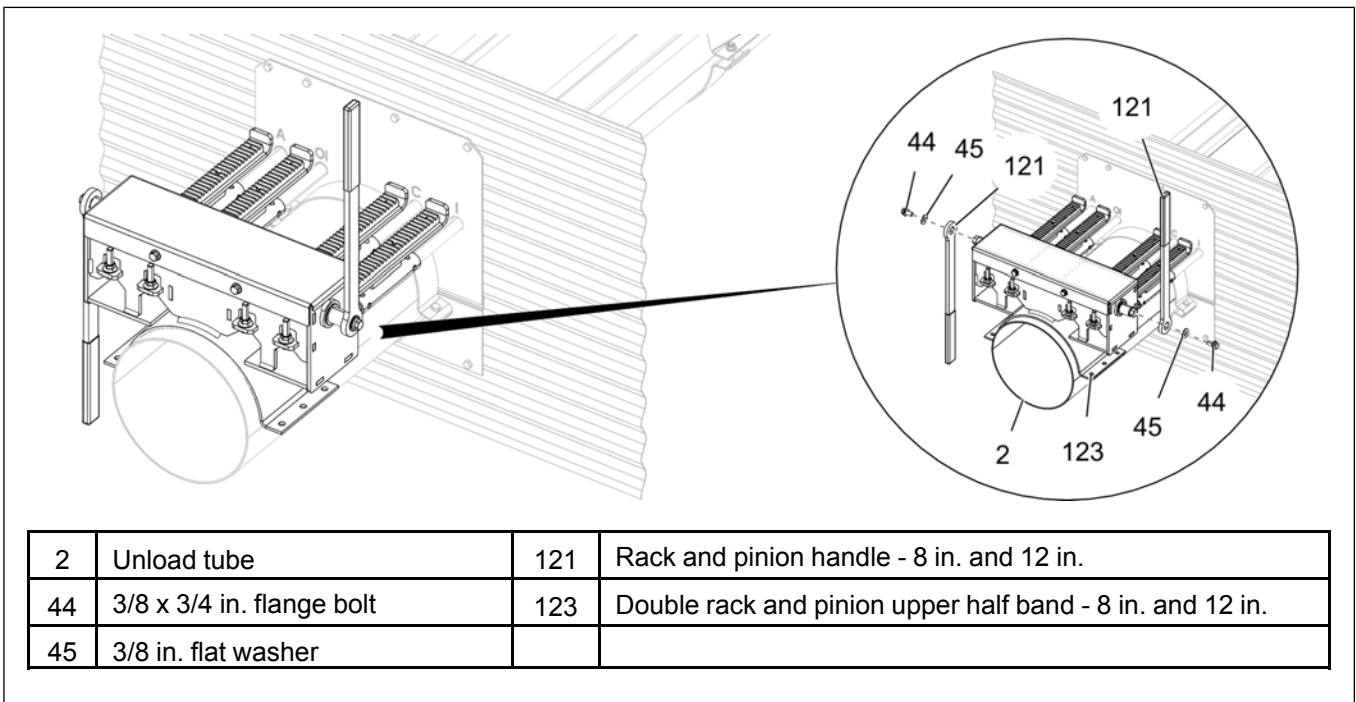
## Chapter 3: Installation

- Slide a handle (43 and 121) over the shafts on each side of the double rack and pinion (42 and 123) and install with 3/8 x 3/4 in. flange bolts (44) and 3/8 in. flat washers (45).

**Figure 3-35** Installing the handle to double rack and pinion - 10 in.



**Figure 3-36** Installing the handle to double rack and pinion - 8 in. and 12 in.





- With rack and pinion fully extended towards the bin wall, attach the lower half band (46 and 122) to the double rack and pinion (42 and 123) and install to the unload tube (2) with 5/16 x 1-1/2 in. HHCS bolts (11), 5/16 in. flat washers (35) and 5/16 in. flange nuts (5).

Figure 3-37 Installing the lower half band to double rack and pinion - 10 in.

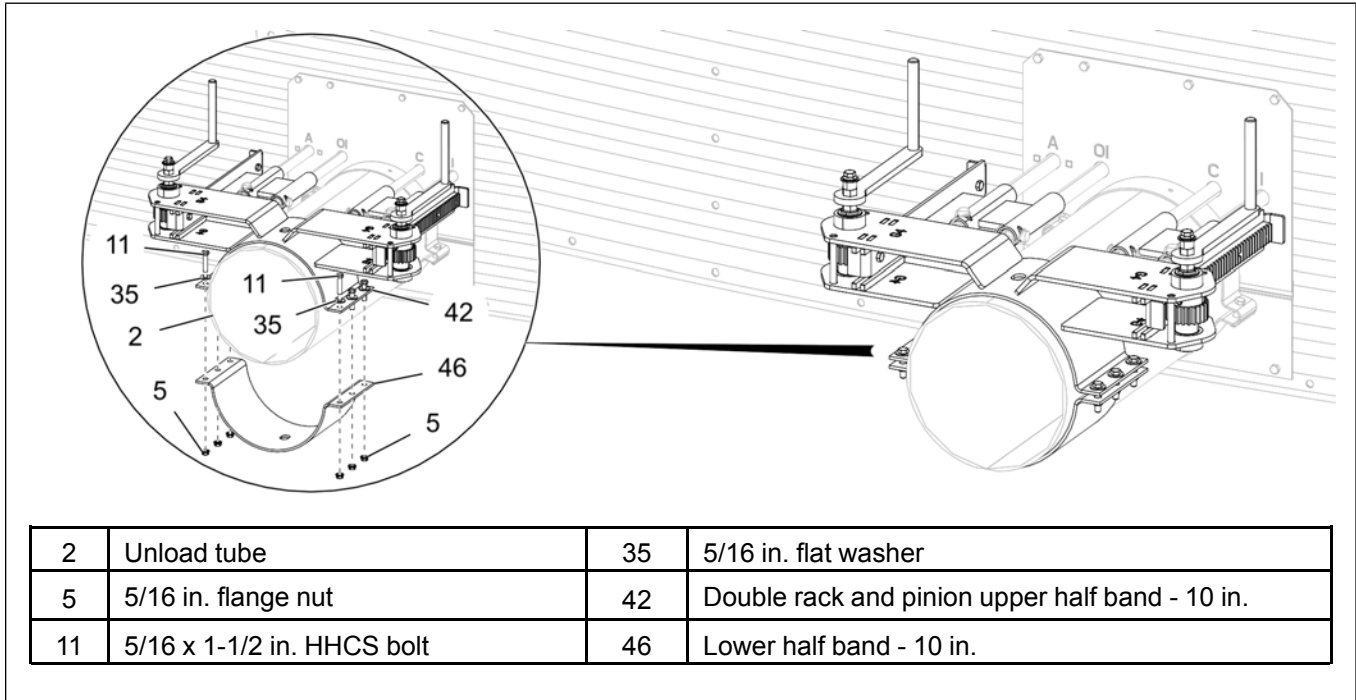
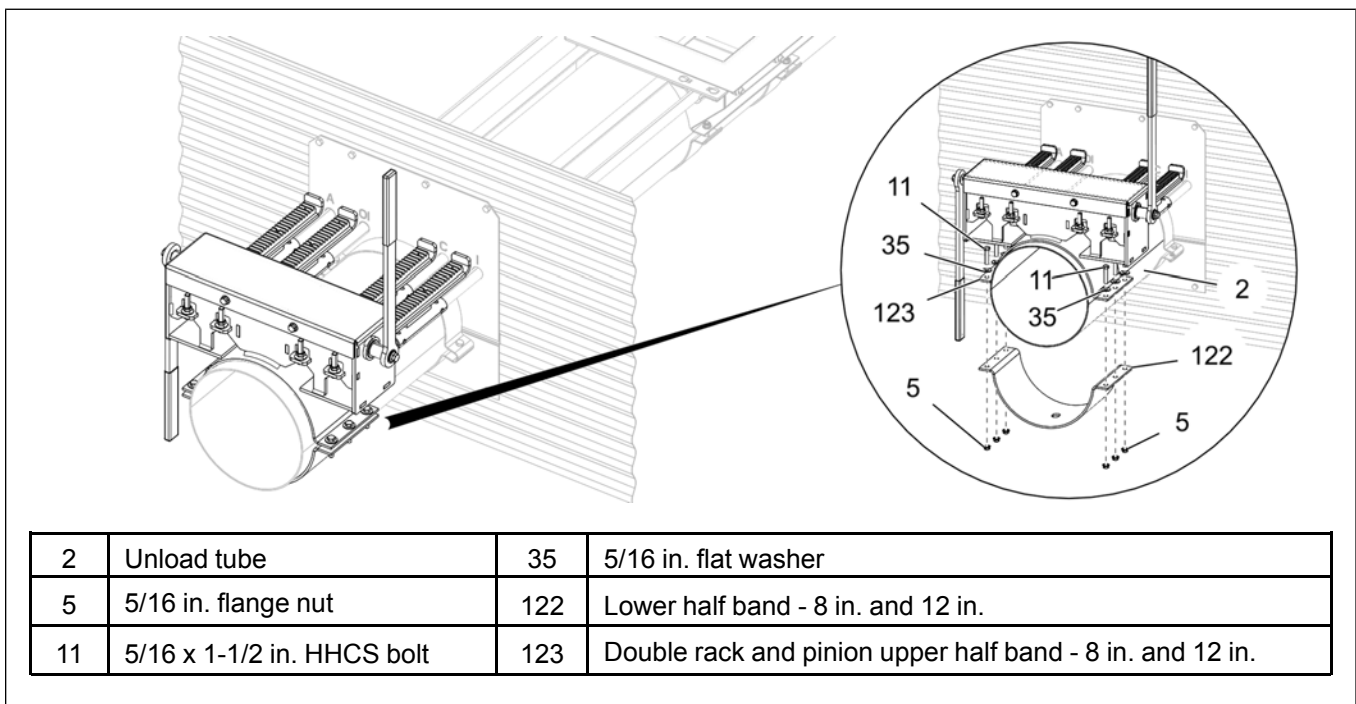


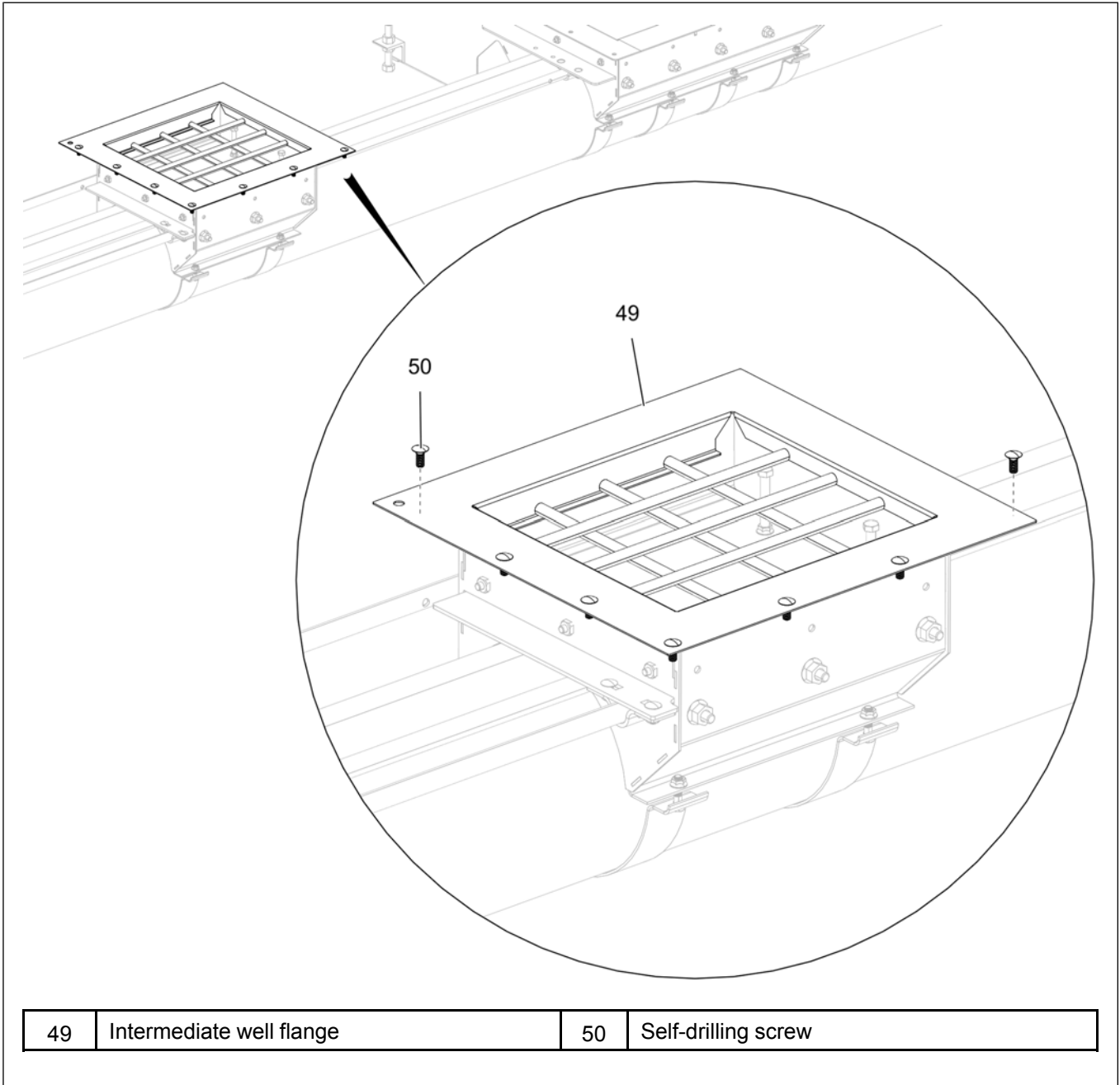
Figure 3-38 Installing the lower half band to double rack and pinion - 8 in. and 12 in.



## Installing Intermediate Well Flanges

1. Place the intermediate well flanges (49) onto the intermediate wells.
2. Use self-drilling screws (50) to install the intermediate well flange (49) to the bin floor.

**Figure 3-39** *Installing the intermediate well flange*



## Assembling the Sweep Flighting to the Backshield (60 ft - 72 ft Bins)

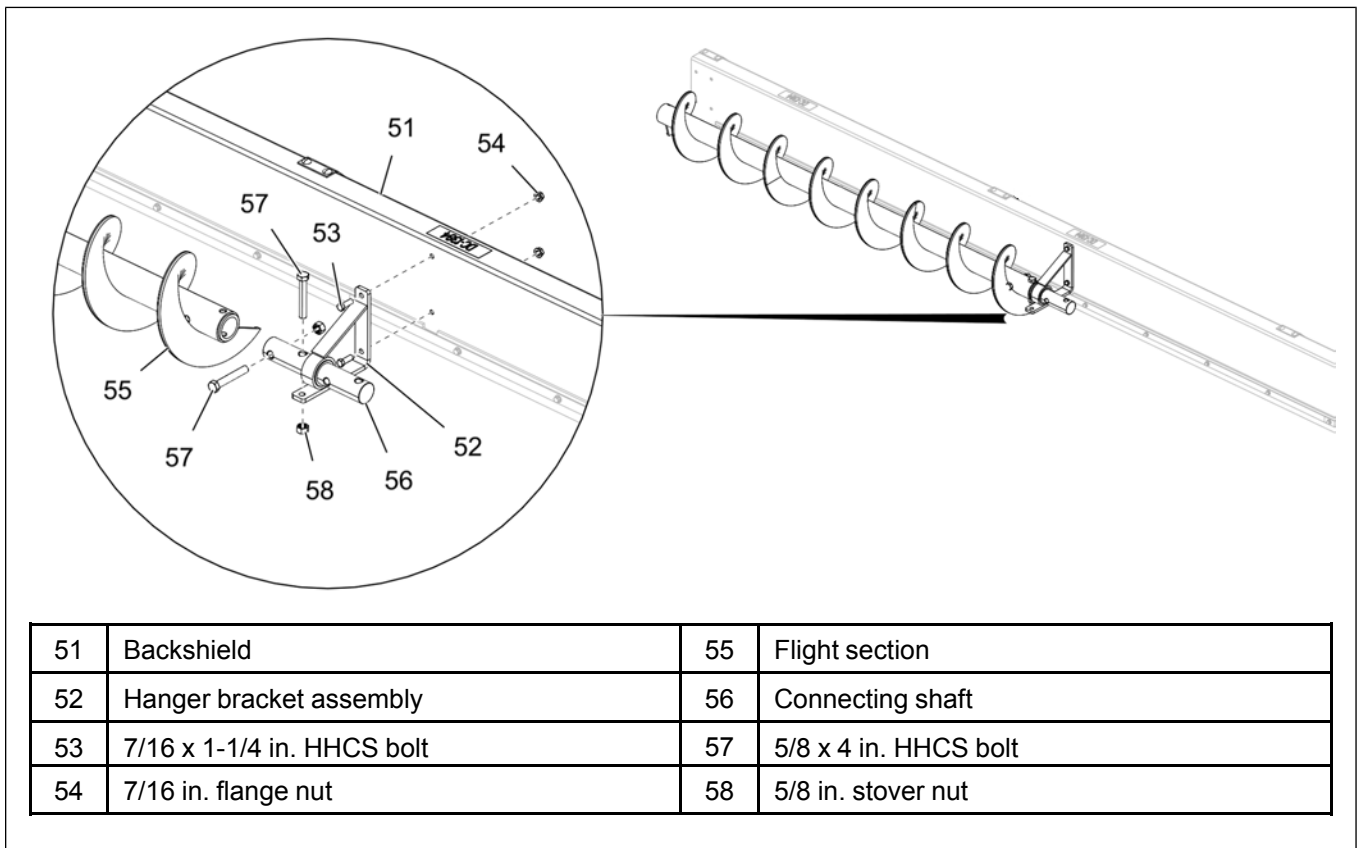
For sweeps up to 54 ft diameter bins, the sweep flighting is pre-assembled to the shield before being shipped. For sweeps above 60 ft diameter bins, the sweep flighting and the shield are not pre-assembled and will need to be assembled before installing them to the U-joint shaft attached to the gearbox.

1. Attach the first hanger bracket assembly (52) to the backshield (51).
2. Slide the connecting shaft (56) into the hanger bracket assembly (52).
3. Attach the first flight section (55) to one end of the connecting shaft (56) using 5/8 x 4 in. HHCS bolts (57) and 5/8 in. stover nuts (58).

**NOTE:** Make sure to assemble the augers with the Dura-Edge® on the grain side (discharge to the pivot) of the flighting.

4. Install the hanger bracket assembly (52) to the backshield (51) using 7/16 x 1-1/4 in. HHCS bolts (53) and 7/16 in. flange nuts (54).

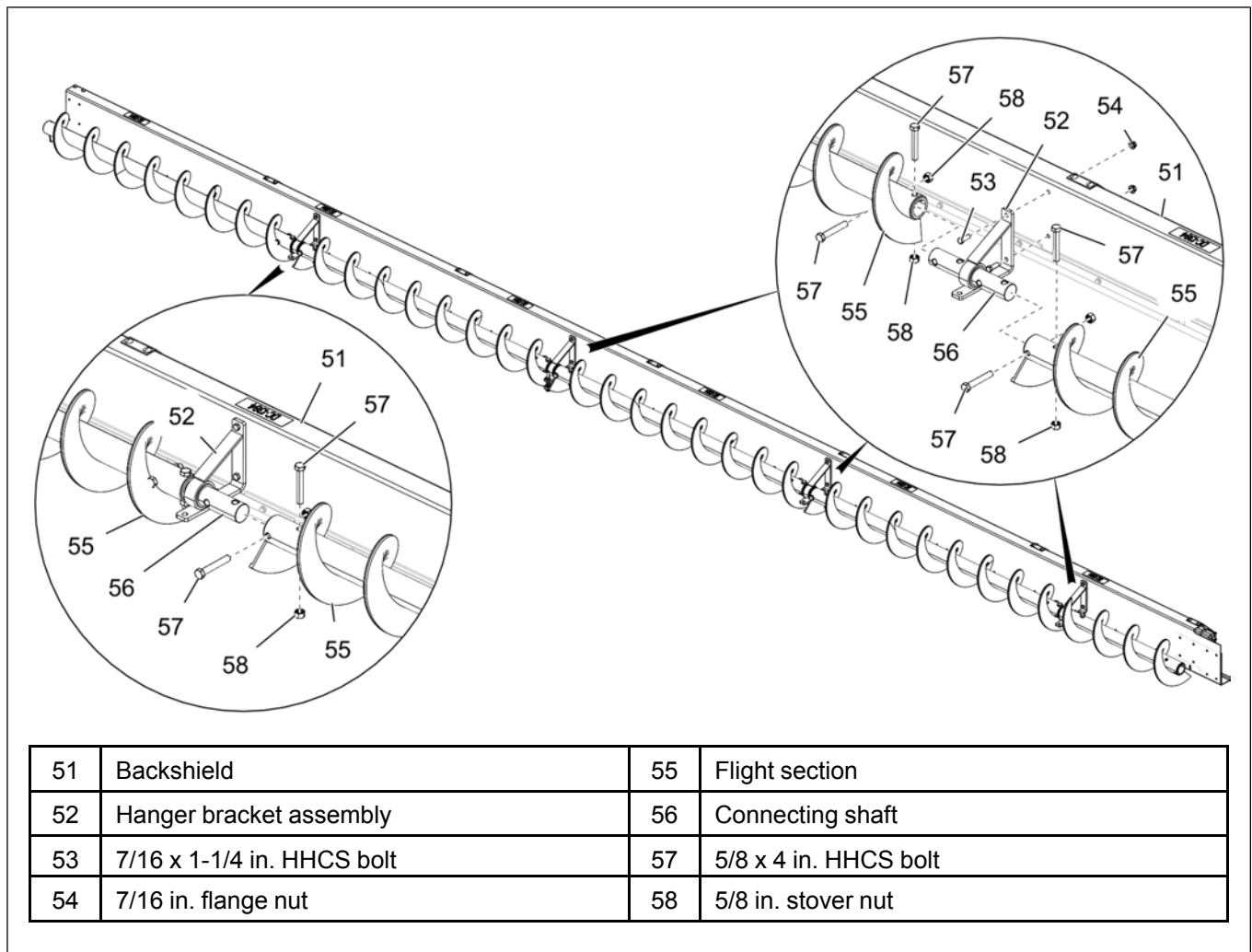
**Figure 3-40** Attaching the first flight section with hanger bracket to the backshield



## Chapter 3: Installation

5. Attach the second hanger bracket assembly (52) to the backshield (51).
6. Slide the connecting shaft (56) into the hanger bracket assembly (52).
7. Attach one end of second flight section (55) to the connecting shaft (56) in the first hanger bracket assembly (52) and the other to the connecting shaft (56) in the second hanger bracket assembly (52) using 5/8 x 4 in. HHCS bolts (57) and 5/8 in. stover nuts (58).
8. Install the hanger bracket assembly (52) to the backshield (51) using 7/16 x 1-1/4 in. HHCS bolts (53) and 7/16 in. flange nuts (54).
9. Repeat the above steps to continue installing the remaining flight sections to the backshield (51).

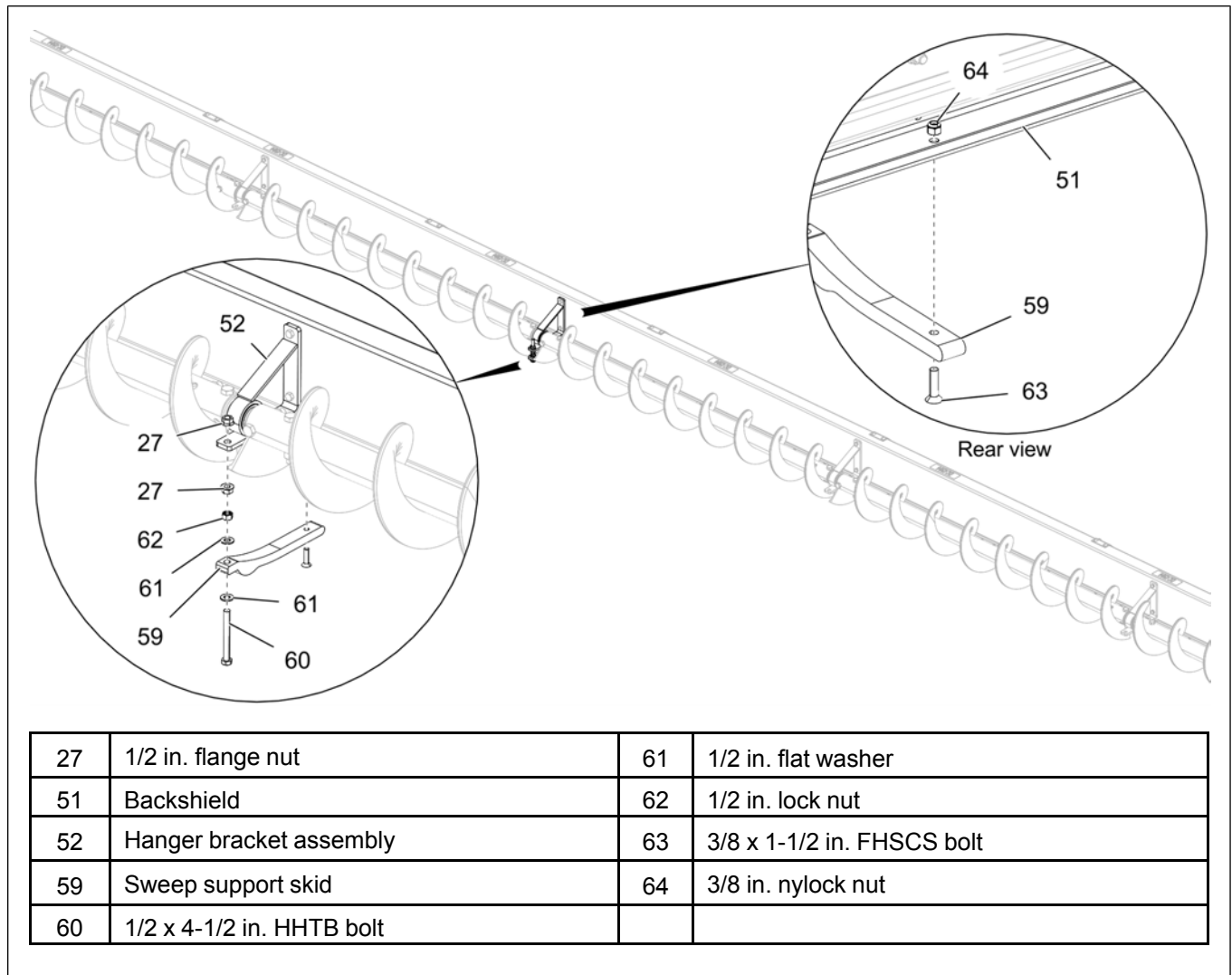
**Figure 3-41** Attaching the second flight section with hanger bracket to the backshield



## Assembling the Sweep Support Skid

1. Attach the sweep support skid (59) to the hanger bracket assembly (52) using 1/2 x 4-1/2 in. HHTB bolt (60), two 1/2 in. flat washers (61), 1/2 in. lock nut (62) and two 1/2 in. flange nuts (27) at the front side of the shield.
2. Attach the sweep support skid (59) to the backshield (51) using 3/8 x 1-1/2 in. FHSCS bolt (63) and 3/8 in. nylock nut (64) at the backside of the shield.

**Figure 3-42** Assembling the sweep support skid

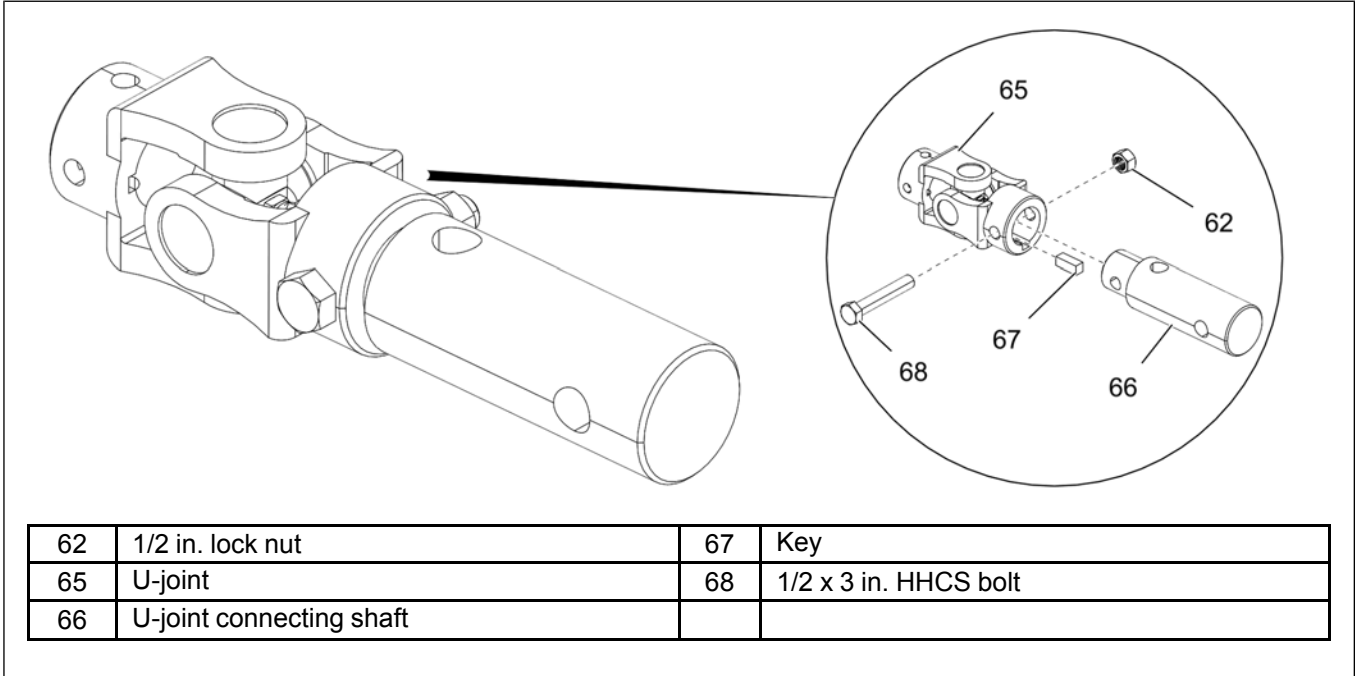


## Installing the Sweep Flighting

1. Assemble the U-joint (65).

**NOTE:** Insert the connecting shaft (66) into the U-joint (65) and secure using a 1/2 x 3 in. HHCS bolt (68), 1/2 in. lock nut (62) and key (67).

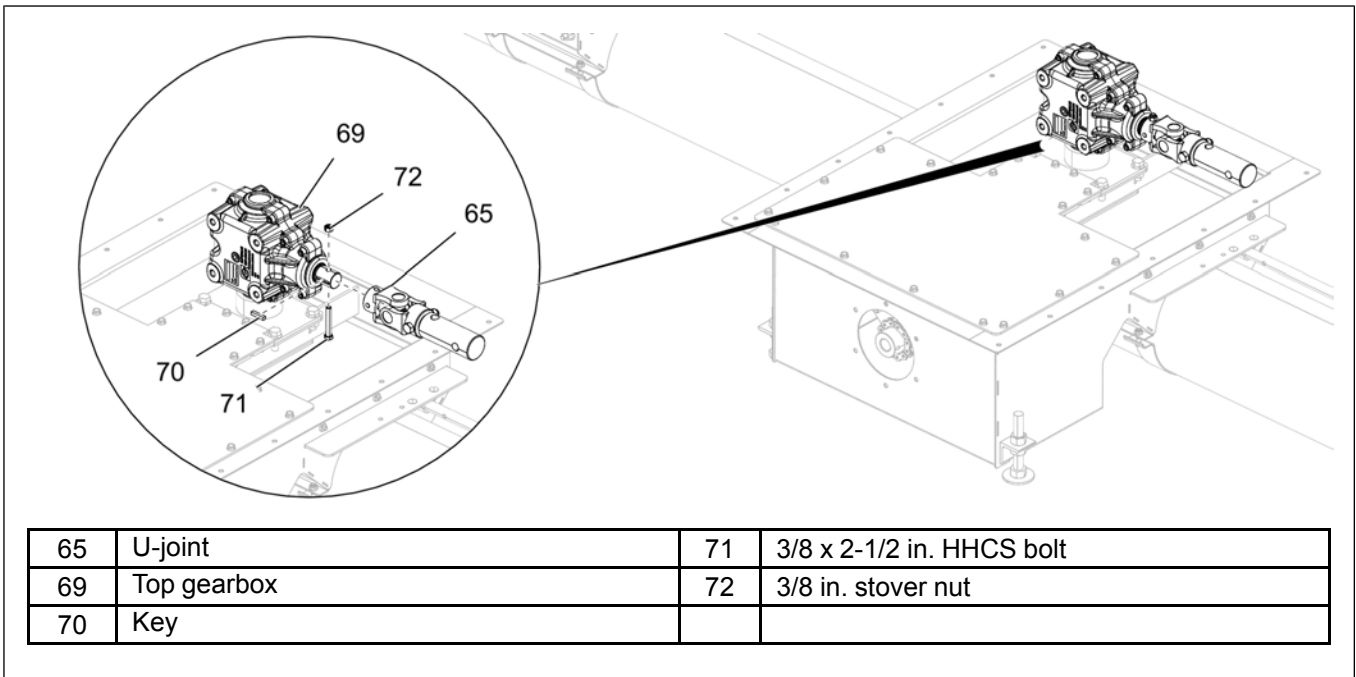
Figure 3-43 Assembling the U-joint



2. Attach the U-joint (65).

**NOTE:** Slide the U-joint (65) onto the top gearbox (69) output shaft and secure using a 3/8 x 2-1/2 in. HHCS bolt (71), 3/8 in. stover nut (72) and key (70).

Figure 3-44 Attaching the U-joint to the gearbox

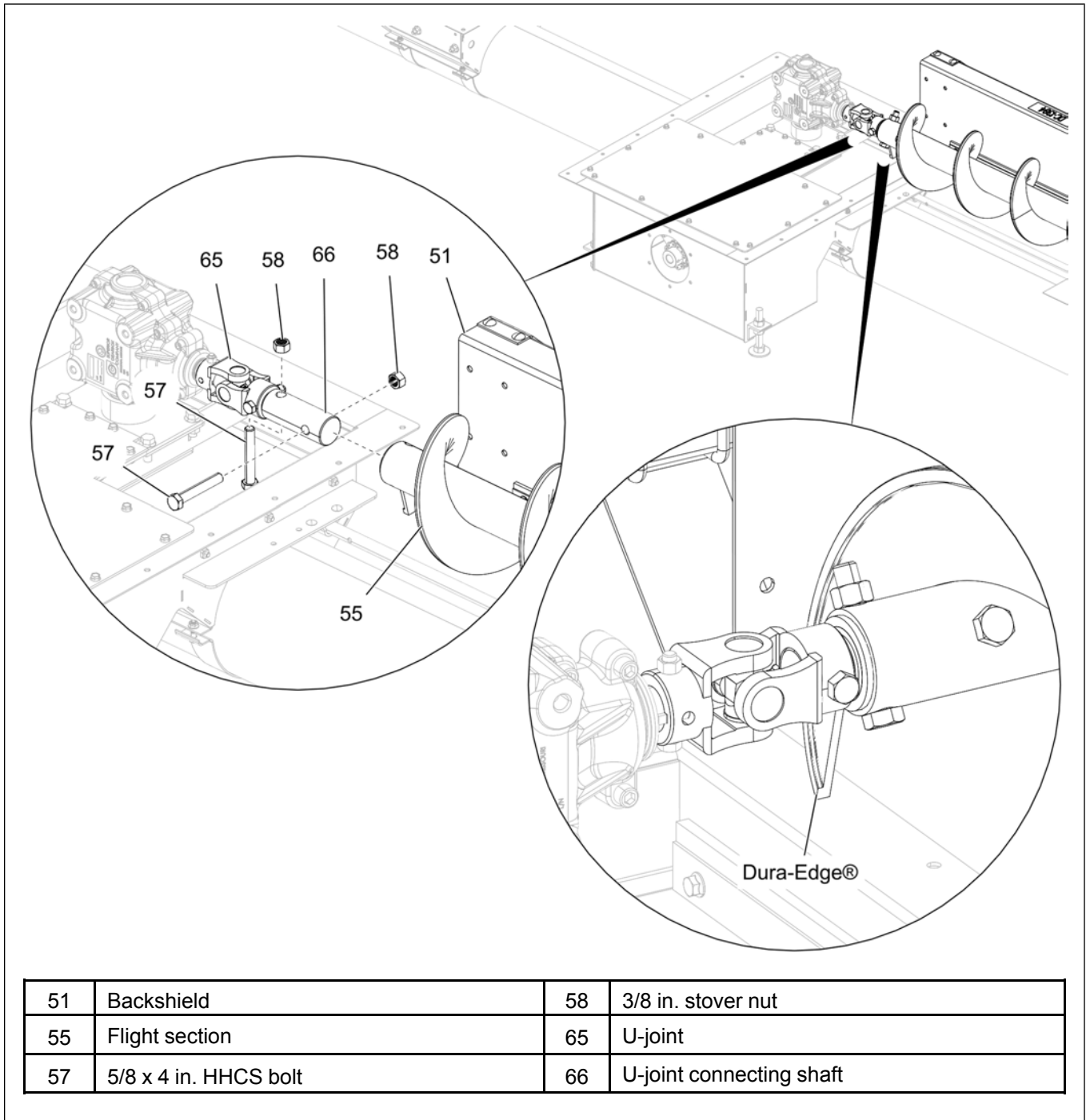




- Attach the first auger section (55) to the U-joint shaft (66) using 5/8 x 4 in. HHCS bolts (57) and 5/8 in. stover nuts (58).

**NOTE:** Make sure that the Dura-Edge® side of the flight (55) faces the center of the bin.

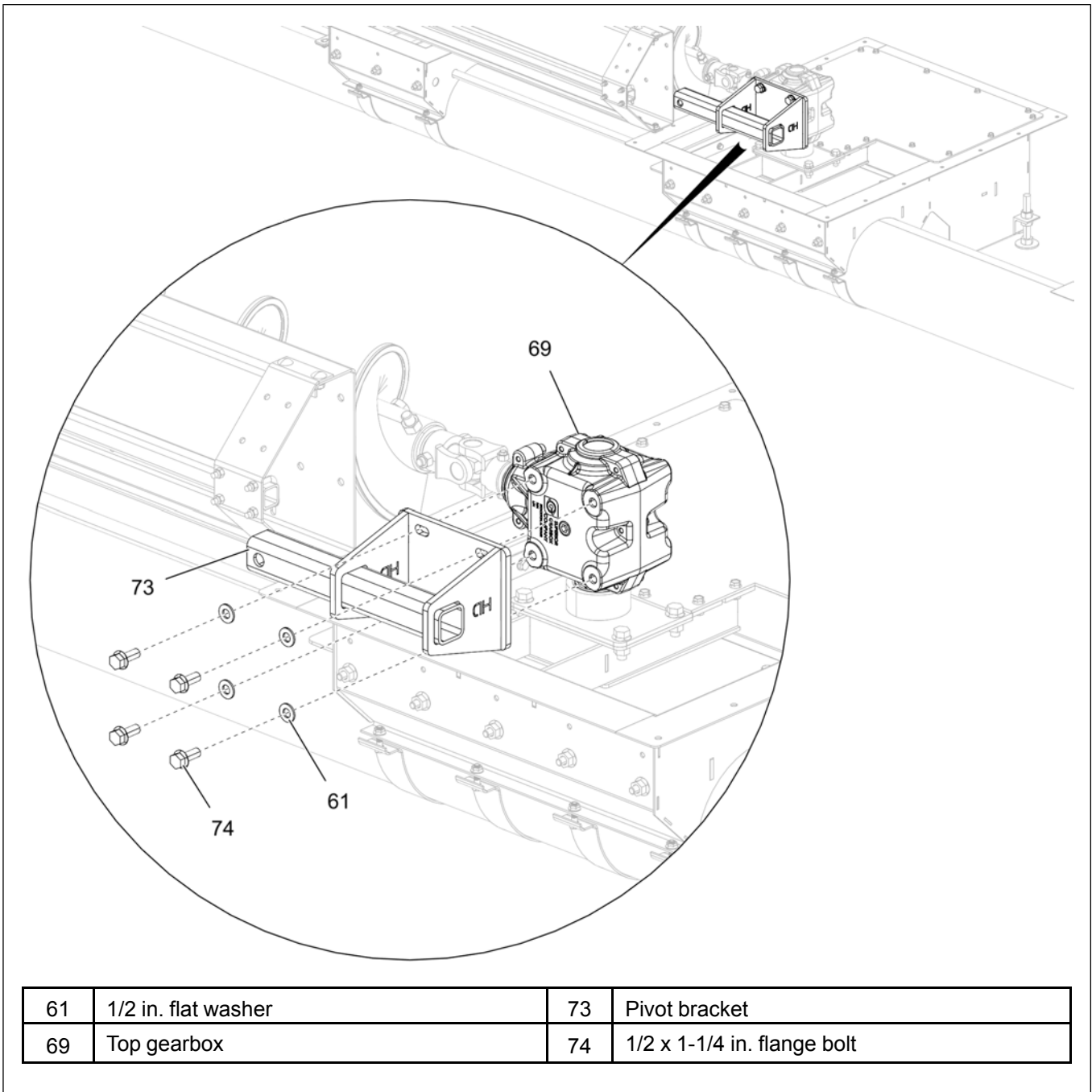
Figure 3-45 Attaching the auger to the U-joint



## Chapter 3: Installation

- Attach the pivot bracket (73) to the side of the gearbox (69) using 1/2 x 1-1/4 in. flange bolts (74) and 1/2 in. flat washers (61).

**Figure 3-46** Attaching the pivot bracket to the gearbox



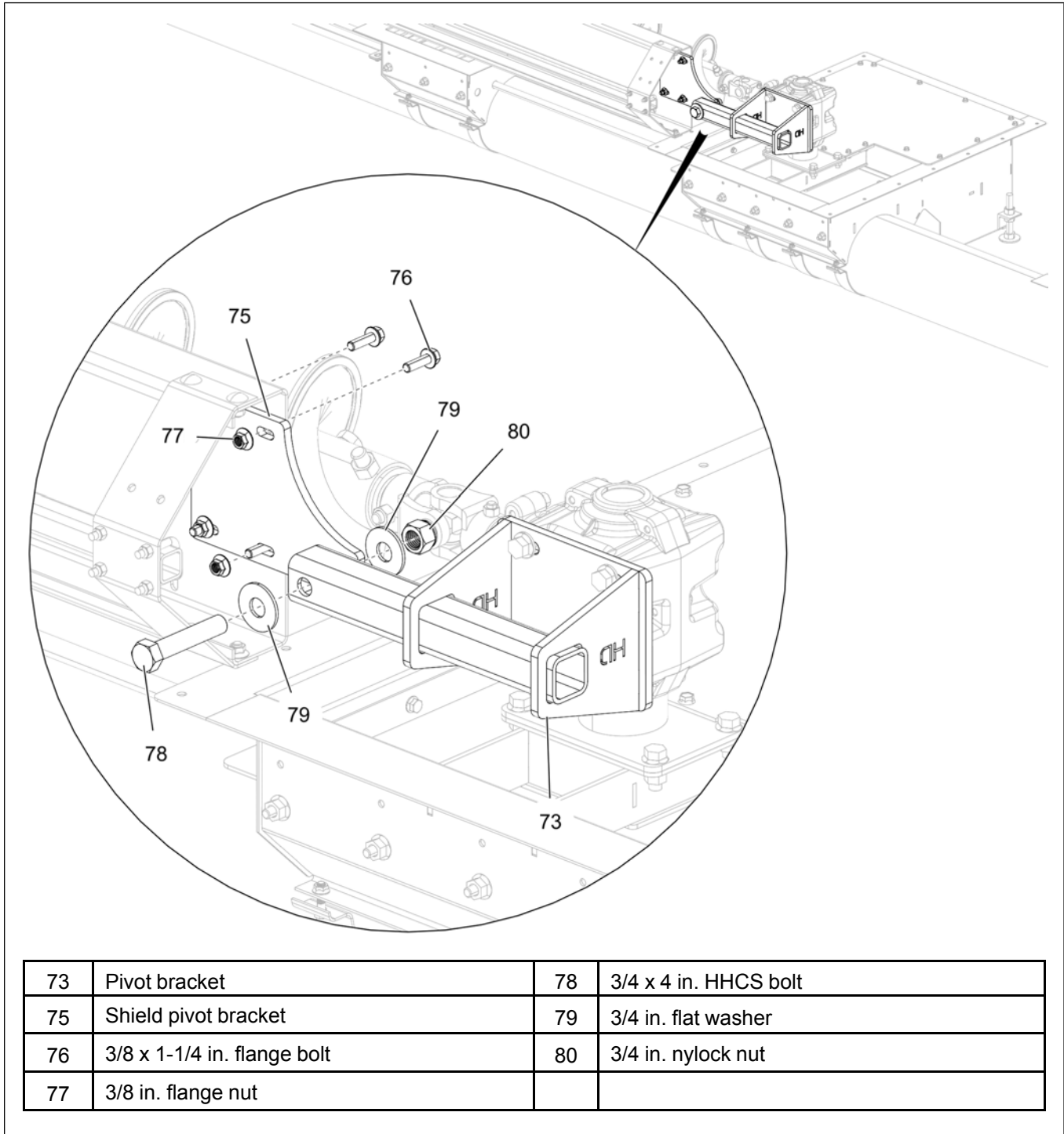


## Installing the Flighting Shield

1. Assemble the shield pivot bracket (75) to the flighting shield using four 3/8 x 1-1/4 in. flange bolts (76) and four 3/8 in. flange nuts (77).
2. Attach the flighting shield pivot bracket (75) to the pivot bracket (73) using a 3/4 x 4 in. HHCS bolt (78), two 3/4 in. flat washers (79) and a 3/4 in. nylock nut (80).

**NOTE:** Do not tighten bolt (78) and nut (80). It should be snug-tightened to pivot freely.

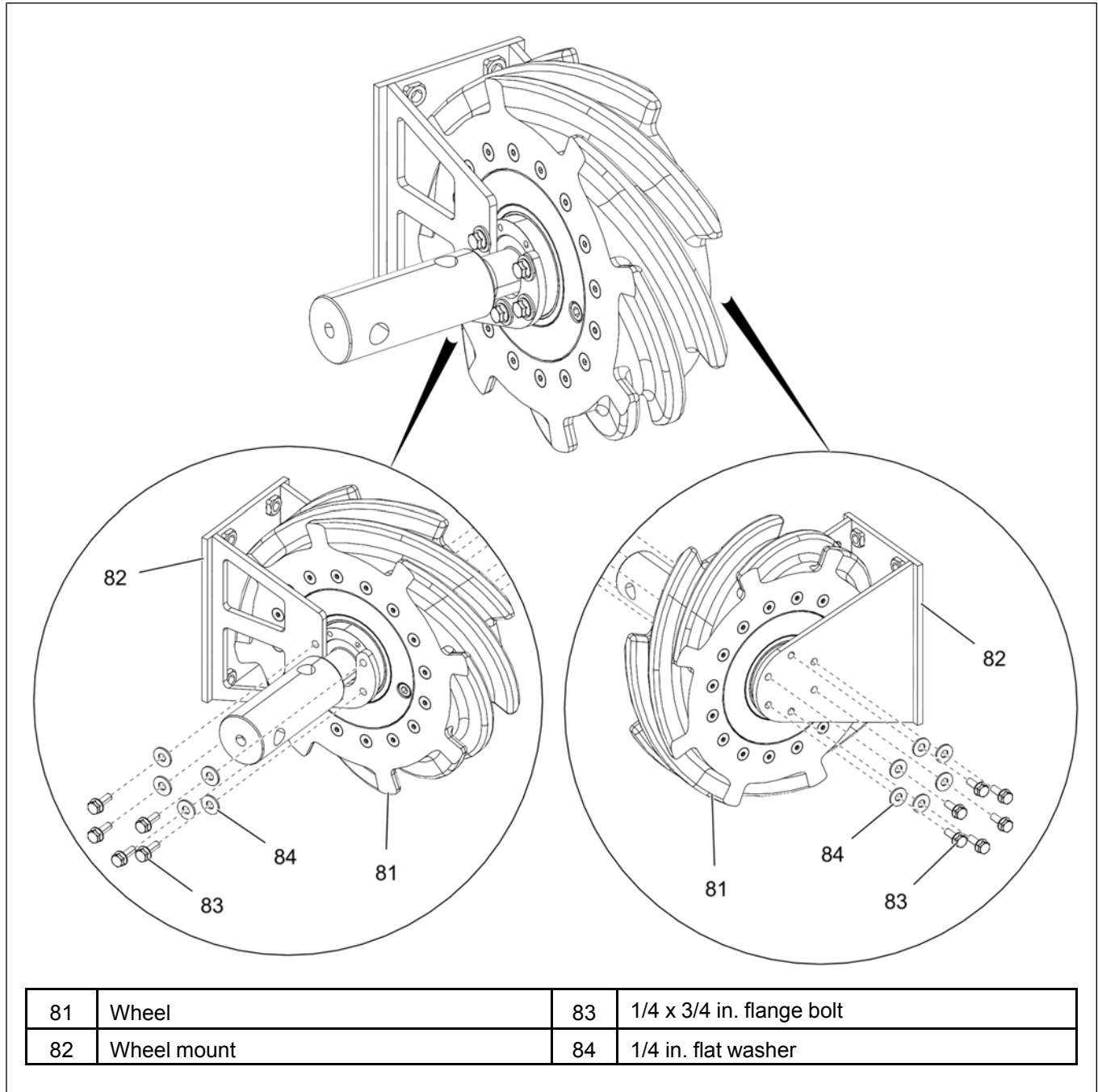
**Figure 3-47** Attaching the flighting shield pivot bracket to pivot bracket



## Installing the Sweep Wheel

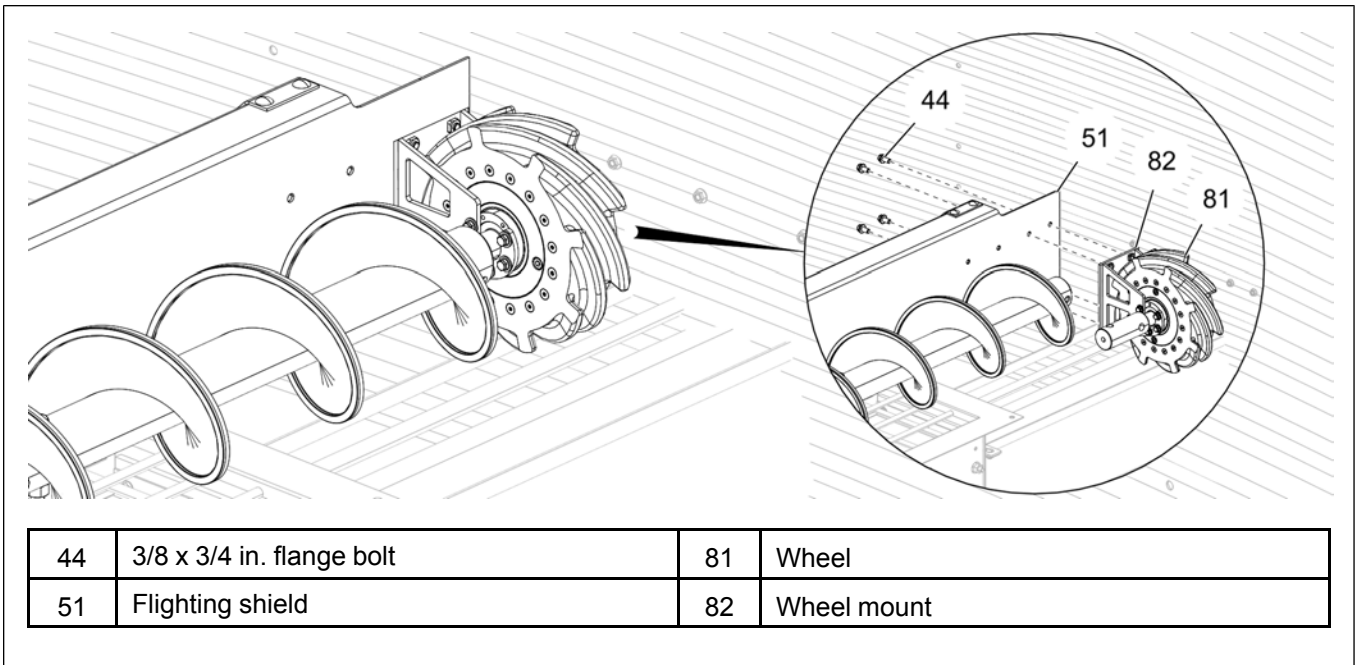
1. Attach the wheel (81) to the wheel mount (82) using eleven 1/4 x 3/4 in. flange bolts (83) and eleven 1/4 in. flat washers (84).

Figure 3-48 Attaching the wheel to wheel mount



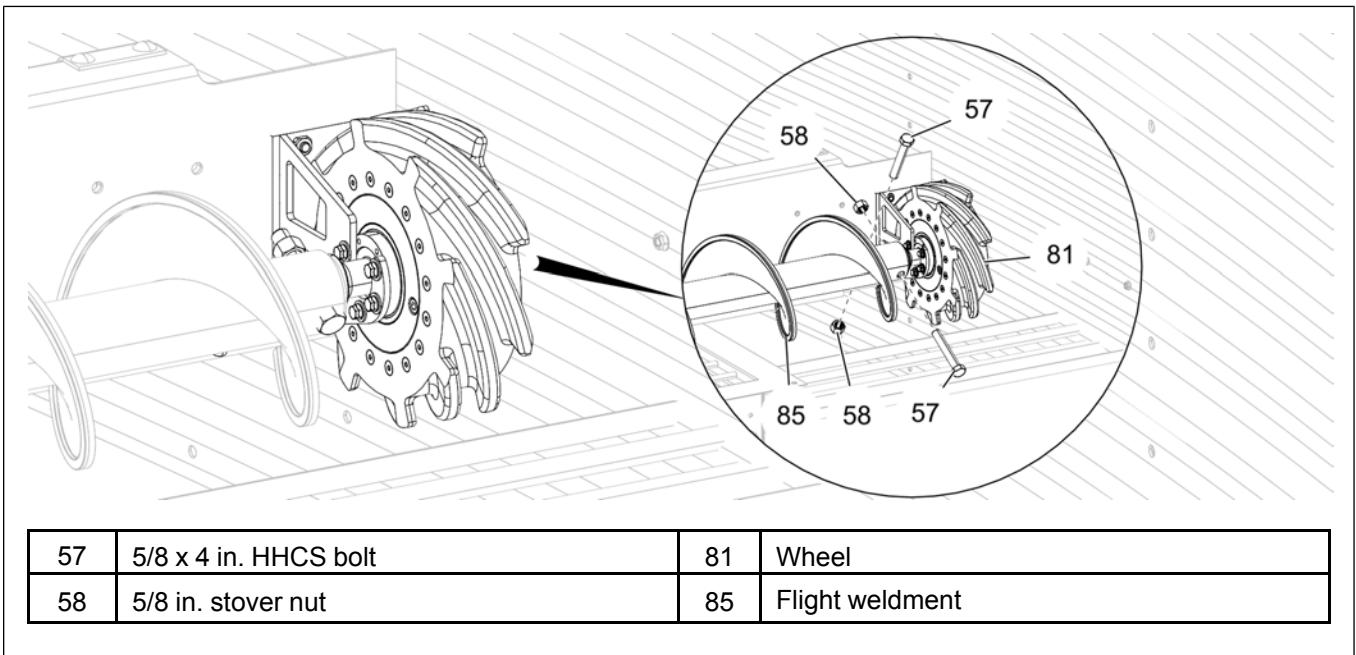
- Slide the wheel shaft (81) into the auger end and install the wheel mount (82) to the shield (51) using four 3/8 x 3/4 in. flange bolts (44).

Figure 3-49 Attaching the wheel mount to shield



- Attach the wheel (81) to the flight weldment (85) with two 5/8 x 4 in. HHCS bolts (57) and 5/8 in. stover nuts (58).

Figure 3-50 Installing the wheel to auger



### Adjusting the Wiper

#### What You Should Know

The wiper should be adjusted based on the highest point of the floor to allow proper clearance, otherwise the sweep will not work as intended.

1. Loosen the 5/16 x 1 in. flange bolts (87) in the backshield assembly to adjust the wiper (86) position.
2. Adjust the wiper (86) UP/DOWN depending on the highest point of the floor within the slots in the backshield assembly.
3. Tighten the wiper (86) in position after adjustment using 5/16 x 1 in. flange bolts (87), 5/16 in. flat washers (35) and 5/16 in. nylock nuts (41).

**Figure 3-51** Wiper in UP position

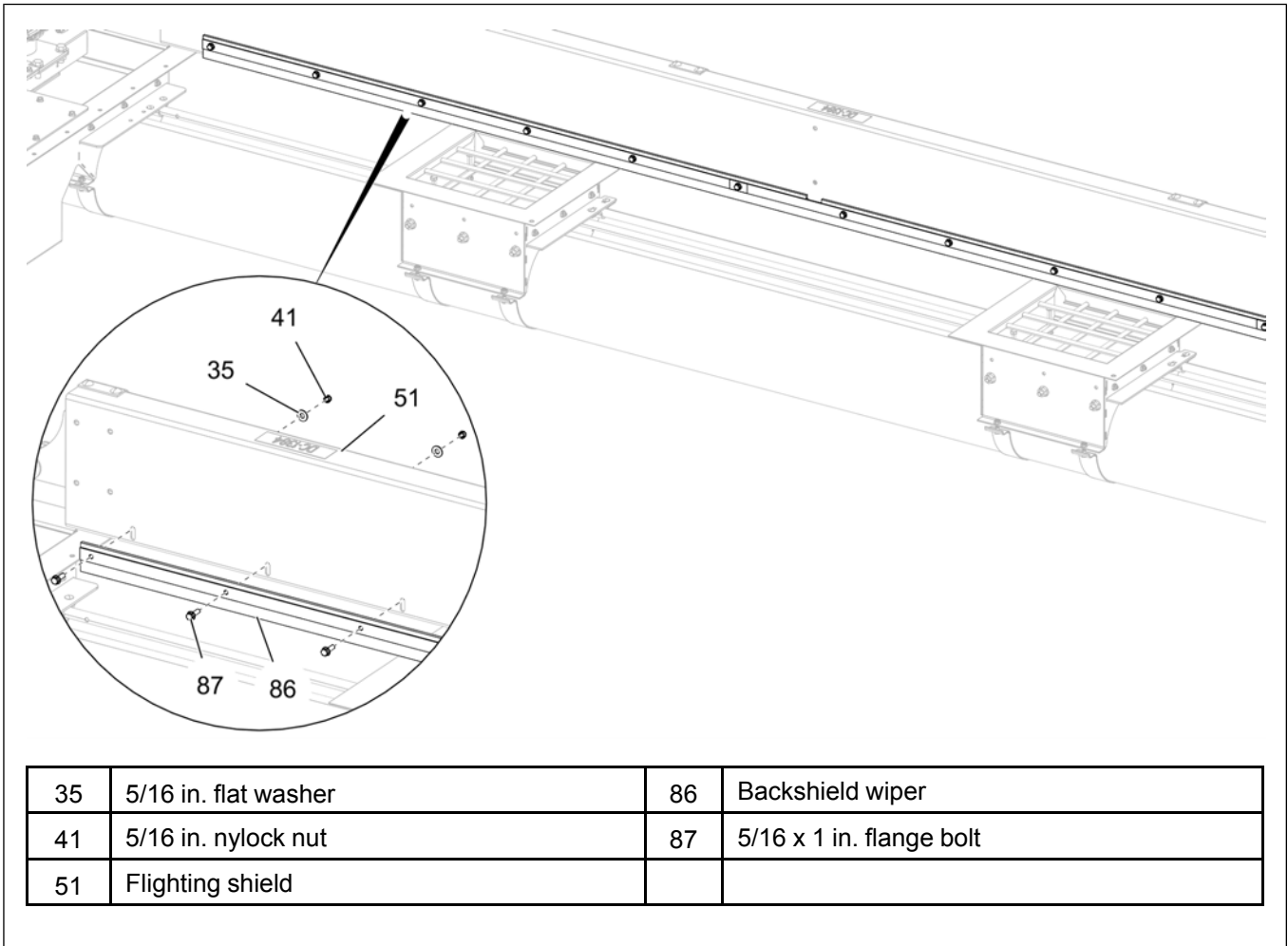
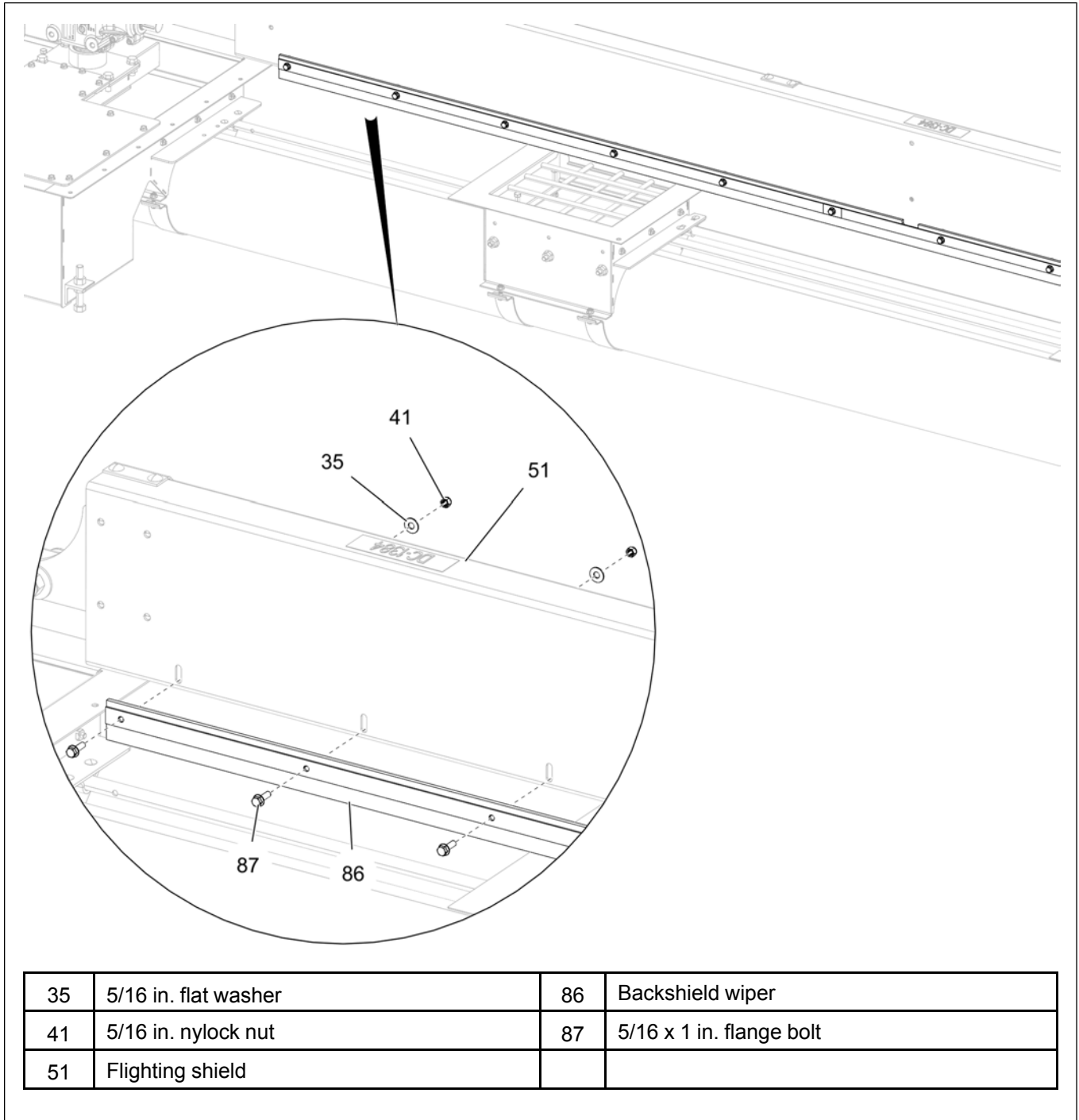


Figure 3-52 Wiper in DOWN position

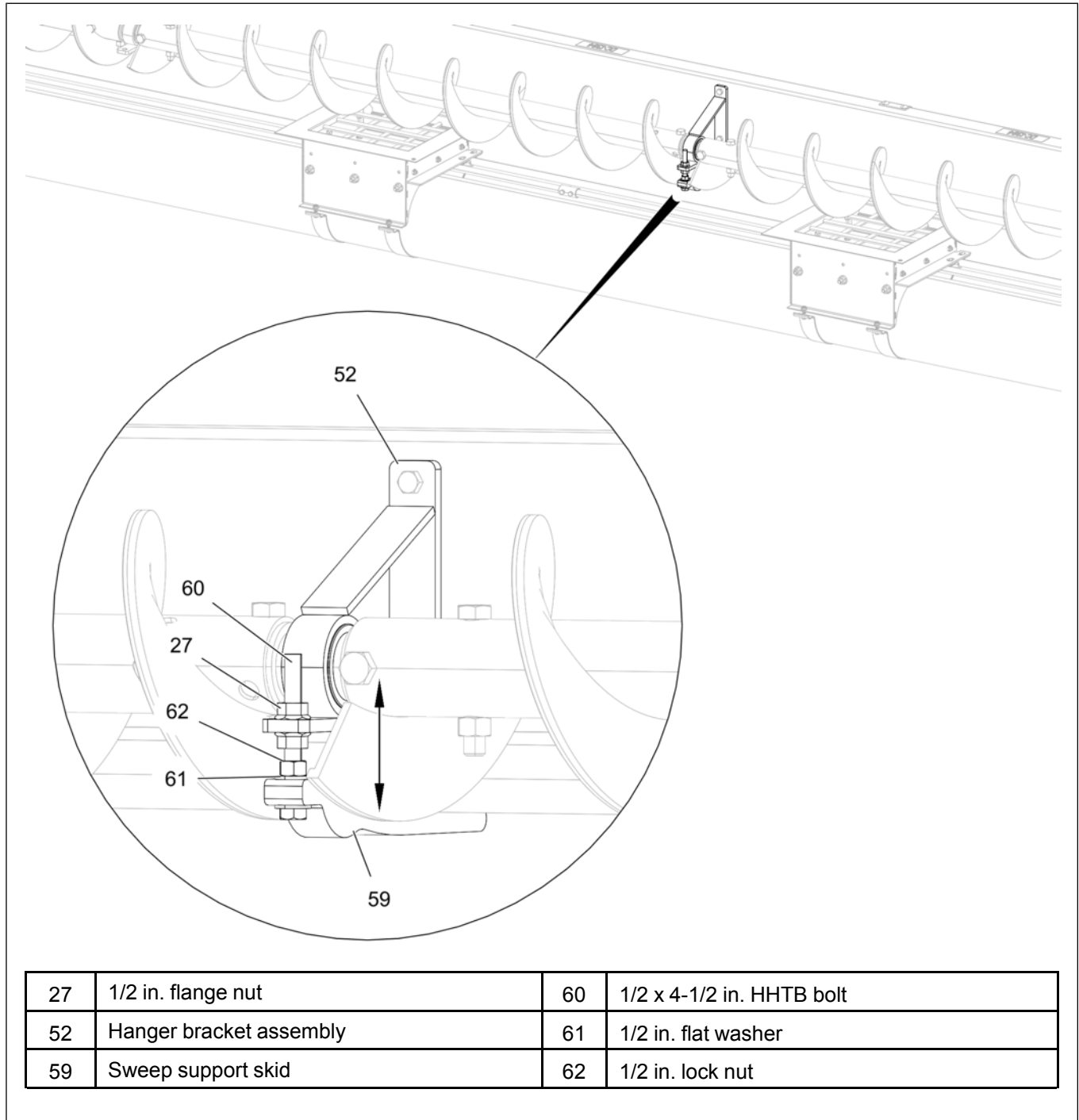


## Adjusting the Sweep Support Skid

Sweep support skid (59) is for 48 ft and larger sweeps.

If necessary, use the 1/2 x 4-1/2 in. HHTB bolts (60) and 1/2 in. flange nuts (27) in the hanger bracket assembly (52) to adjust the height of the auger off the floor for clearance.

**Figure 3-53** Adjusting the sweep support skid



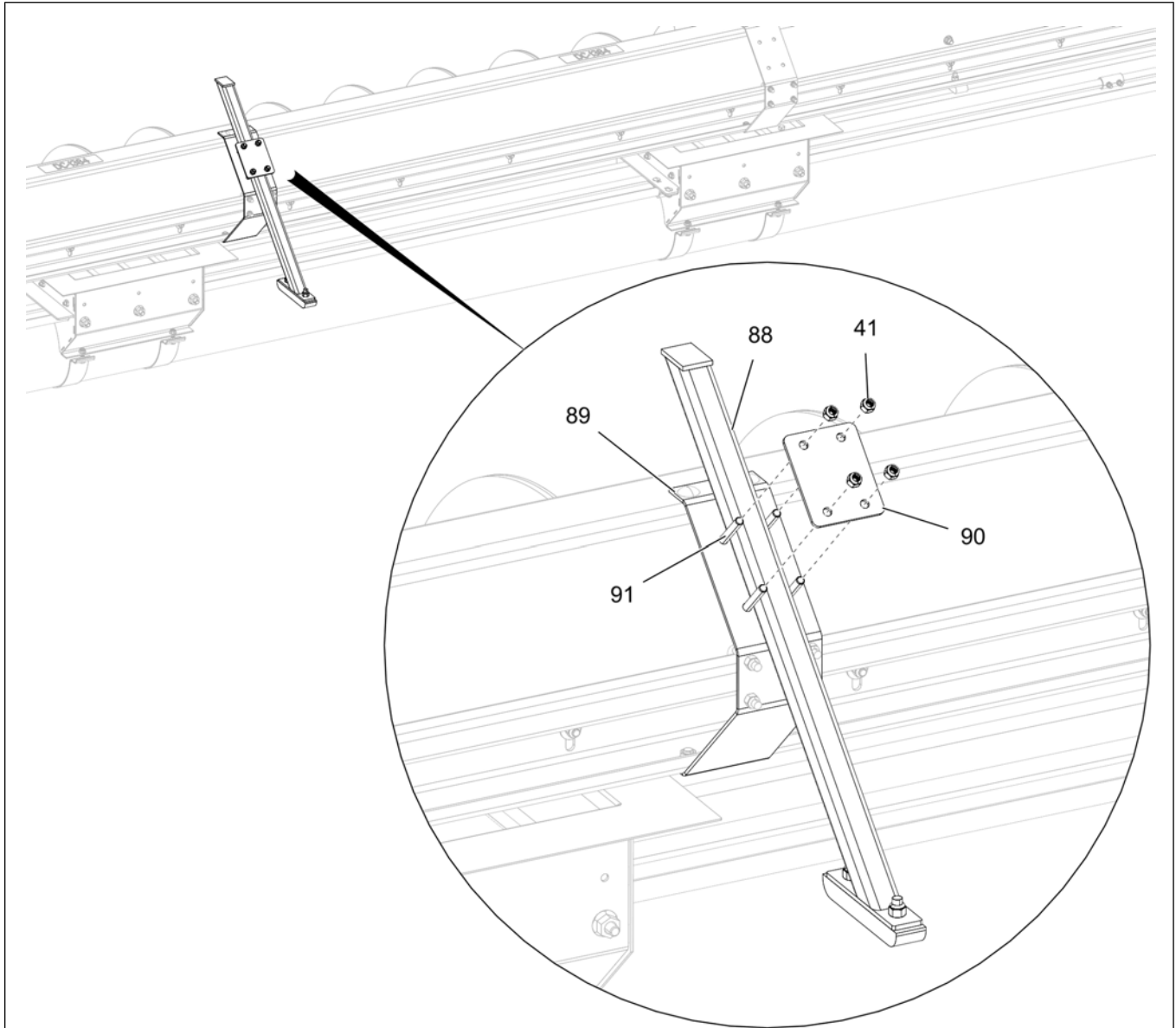


## Installing the Backshield Support Assembly

1. Install the backshield support assembly (88) to the torque tube bracket (89) using mounting plate (90), 5/16 x 2 in. HHCS bolts (91) and 5/16 in. nylock nuts (41).

**NOTE:** The backshield support assembly (88) should be installed at a bracket location that does not interfere with any intermediate wells.

**Figure 3-54** Installing the backshield support assembly



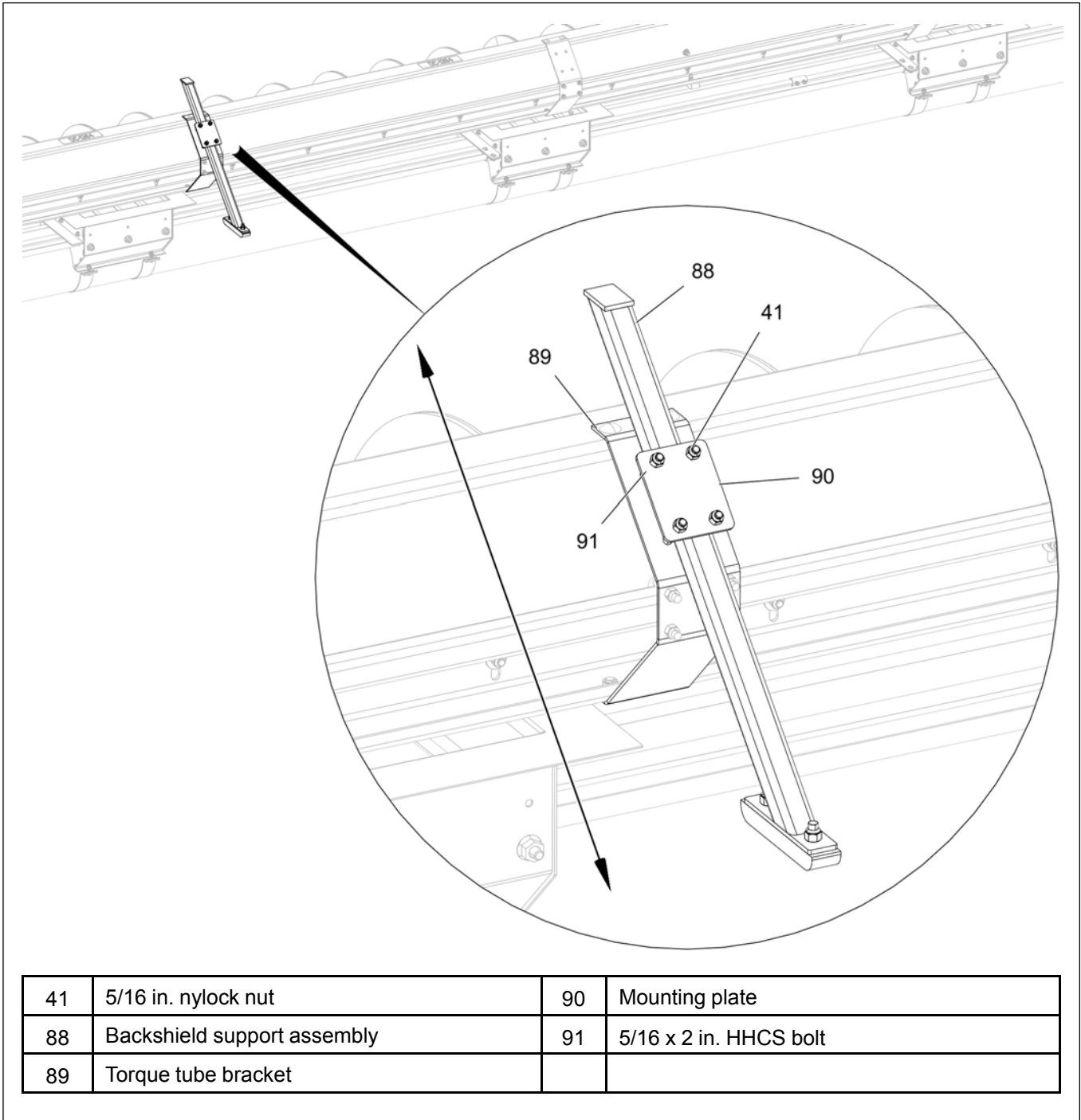
41	5/16 in. nylock nut	90	Mounting plate
88	Backshield support assembly	91	5/16 x 2 in. HHCS bolt
89	Torque tube bracket		

## Chapter 3: Installation

- The backshield support assembly (88) can be adjusted in the direction (as shown) for proper sweep clearance.

**NOTE:** When sliding the support down closer to the floor, it will raise the sweep off the floor and put pressure onto the reduction wheel.

**Figure 3-55** Adjusting the backshield assembly

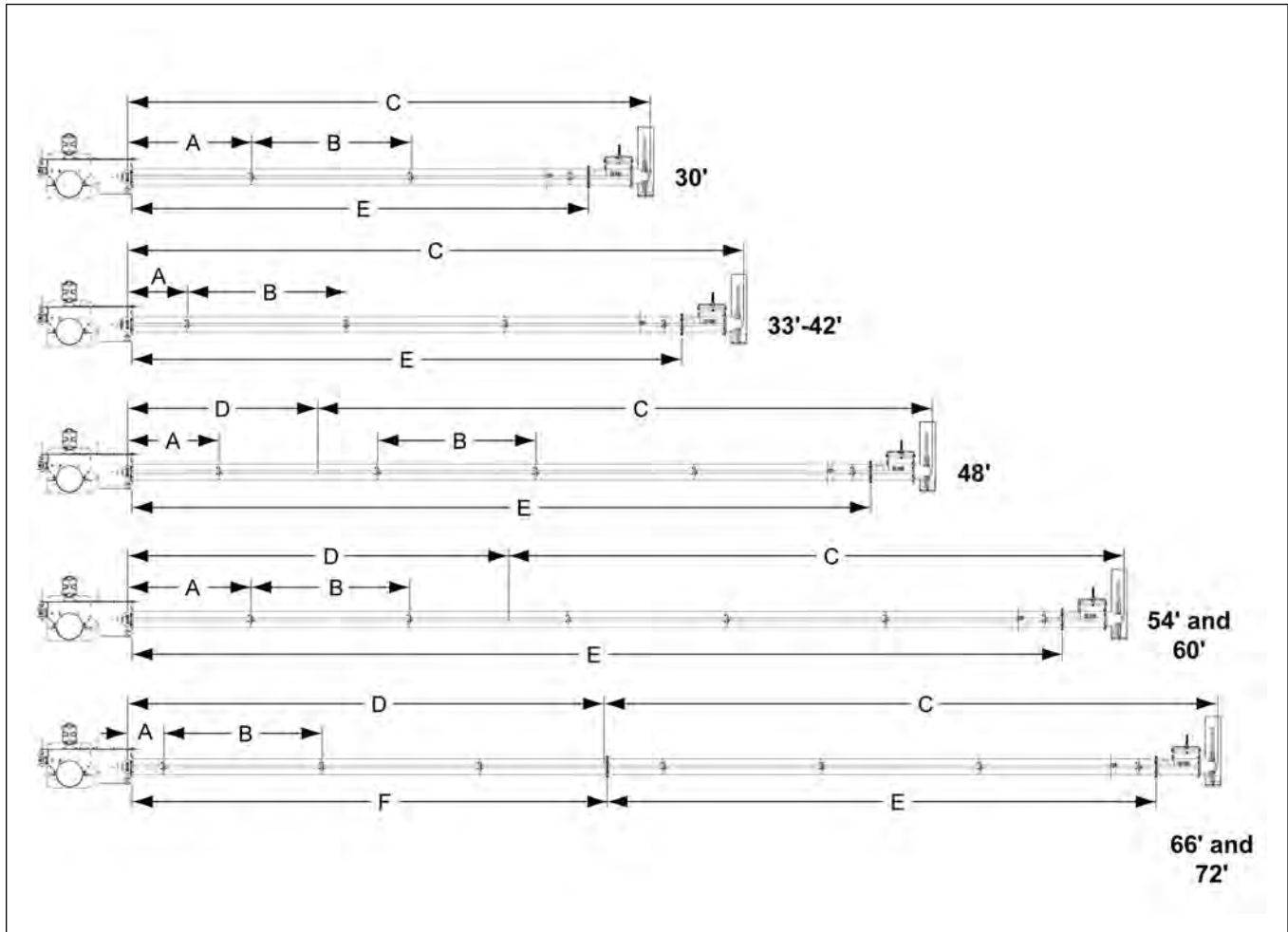




## Drive Assembly and Power Tube Layout

The drive shaft and its housing tube can now be assembled. On bin diameters of 48 ft. through 72 ft. there will be two sections of drive shafts. On bin diameters of 66 ft. and 72 ft. there will be two housing tubes that will be joined together. Lay the sections of housing tubes and drive shafts in an open area and using the chart and illustration below, determine the proper order of each prior to actual placement in the bin.

Figure 3-56 Drive assembly and power tube layout

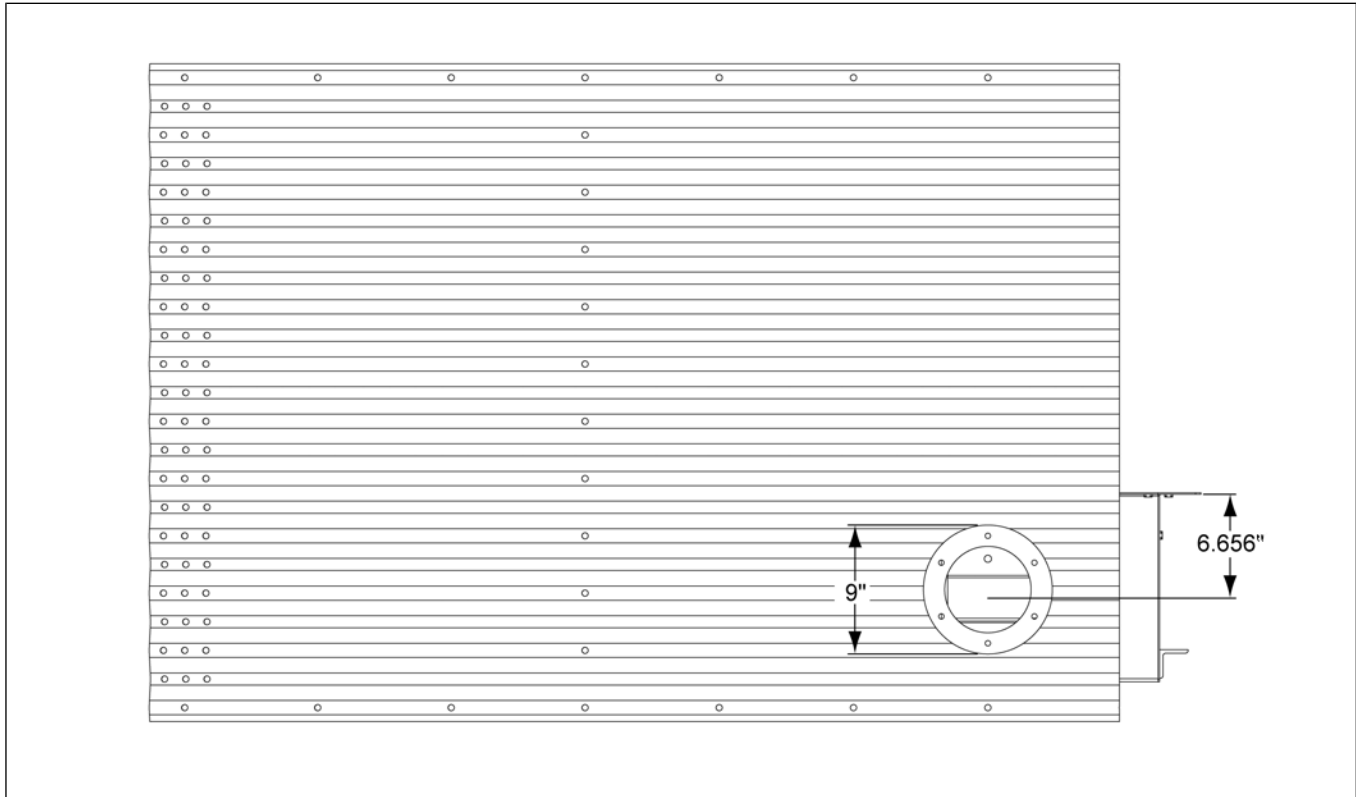


Bin diameter	# of bearings	Distance from drive coupler to first bearing (A)	Distance between support bearings (B)	Power shaft length (C)	Power shaft extension length (D)	Power housing tube length (E)	Power housing tube length (F)
30'	3	3' - 10-5/8"	60"	16' - 4-5/8"	-	14' - 4"	-
33'	4	4-5/8"	60"	17' - 10-5/8"	-	15' - 10"	-
36'	4	1' - 10-5/8"	60"	19' - 4-5/8"	-	17' - 4"	-
39'	4	4 - 5/8"	60"	17' - 10-5/8"	-	15' - 10"	-
42'	4	4' - 10-5/8"	60"	19' - 4-5/8"	3'	20' - 4"	-
48'	5	2' - 10-5/8"	60"	19' - 4-5/8"	6'	23' - 4"	-
54'	6	10-5/8"	60"	19' - 4-5/8"	9'	26' - 4"	-
60'	6	3' - 10-5/8"	60"	19' - 4-5/8"	12'	29' - 4"	-
66'	7	1' - 1-3/4"	60"	19' - 4-5/8"	15' - 7/16"	17' - 4"	15' - 3/8"
72'	7	4' - 1-3/4"	60"	19' - 4-5/8"	18' - 7/16"	17' - 4"	15' - 3/8"

### Installing the Power Tube

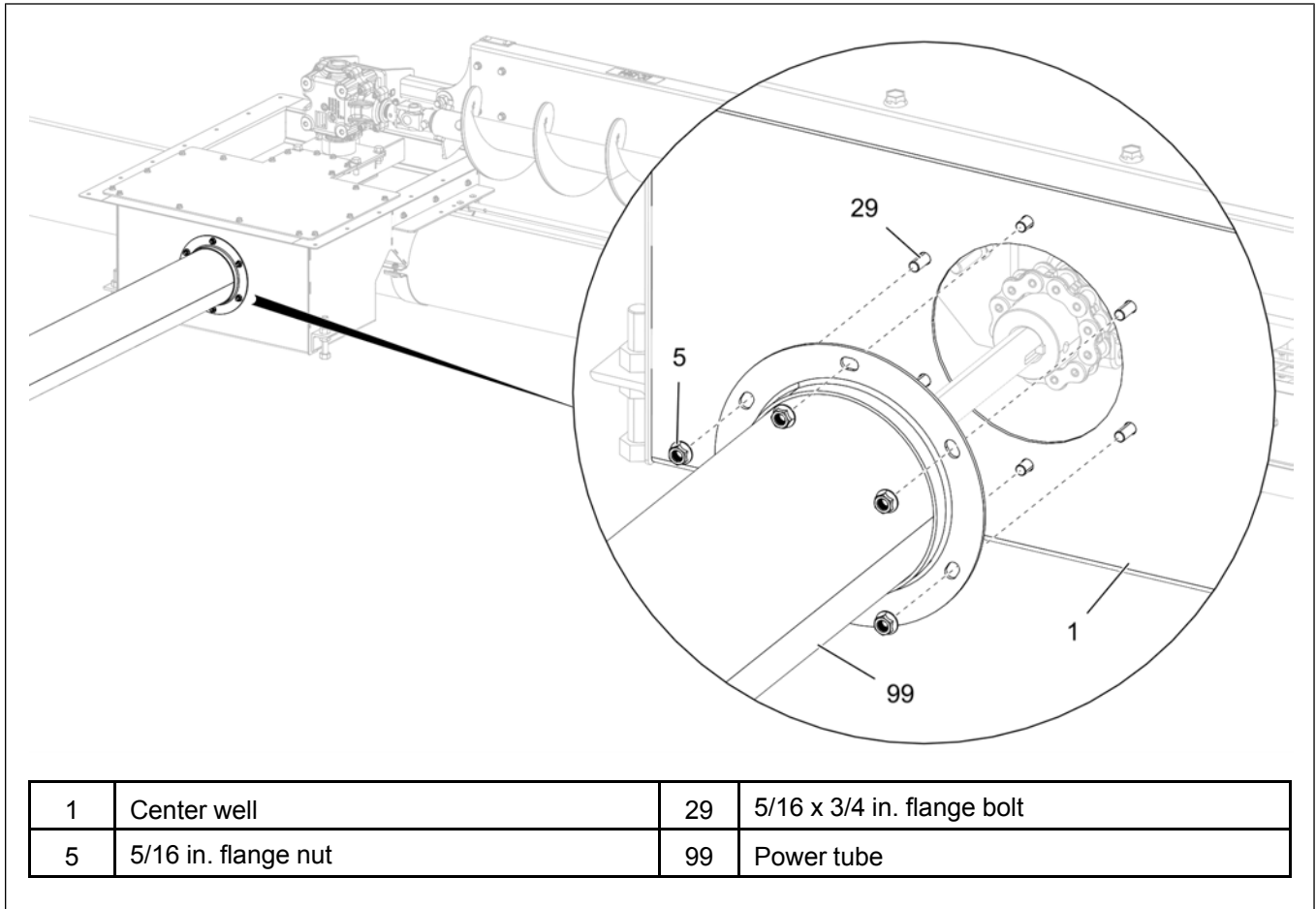
1. Mark the location for the power tube in the bin wall and cut an opening for the power tube to pass through.

Figure 3-57 Sidewall opening details (power tube)



2. Insert the power tube (99) through the hole in the bin wall and align the tube flange with the outside of the center well (1).
3. Secure the power tube (99) to the center well (1) using 5/16 x 3/4 in. flange bolts (29) and 5/16 in. flange nuts (5).

Figure 3-58 Secure the power tube to the center well



The chart shows the minimum number of supports that should be placed beneath the span of tubing. Even though the smaller diameter bins may not require any supports, it is always a good idea to have at least one support positioned in the center of these shorter spans.

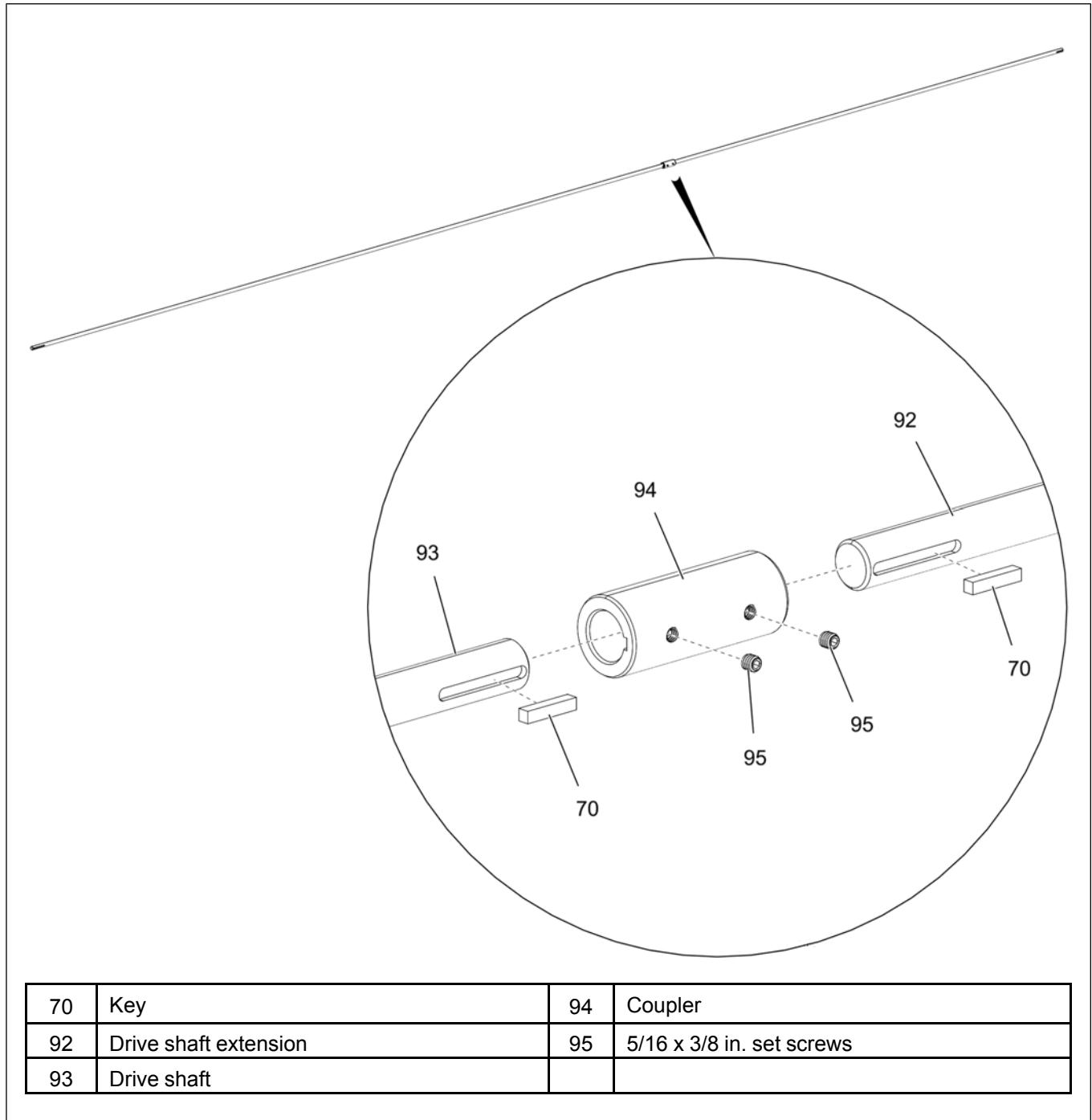
Bin diameter	Minimum No. of Supports
24'-42'	1
48'-60'	2
66'-72'	3

## Assembling the Drive Shafts (42 ft - 72 ft Only)

1. Assemble the drive shaft (93) and drive shaft extension (92) together using the coupler (94), 5/16 x 3/8 in. set screws (95) and keys (70).

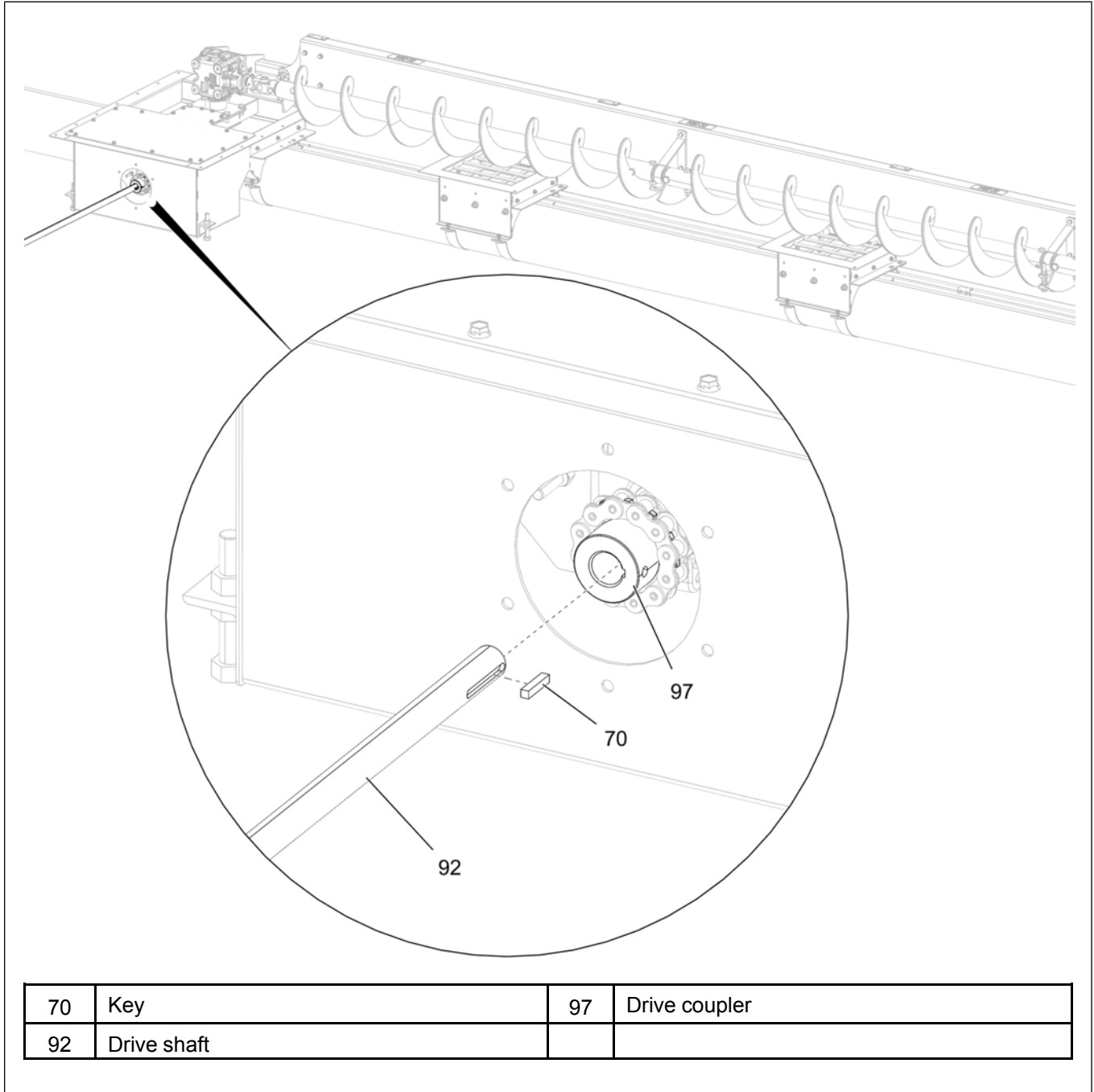
**NOTE:** Loosen the set screws (95) from the coupler (94) before sliding in the shafts (92 and 93). After the shafts are inserted completely, re-tighten the set screws.

Figure 3-59 Assembling the drive shafts (42 ft - 72 ft only)



- Loosen the set screws on the drive coupler (97) in the center well and insert the drive shaft (92) into the drive coupler (97). Secure the drive shaft (92) with a key (70) and re-tighten the set screws.

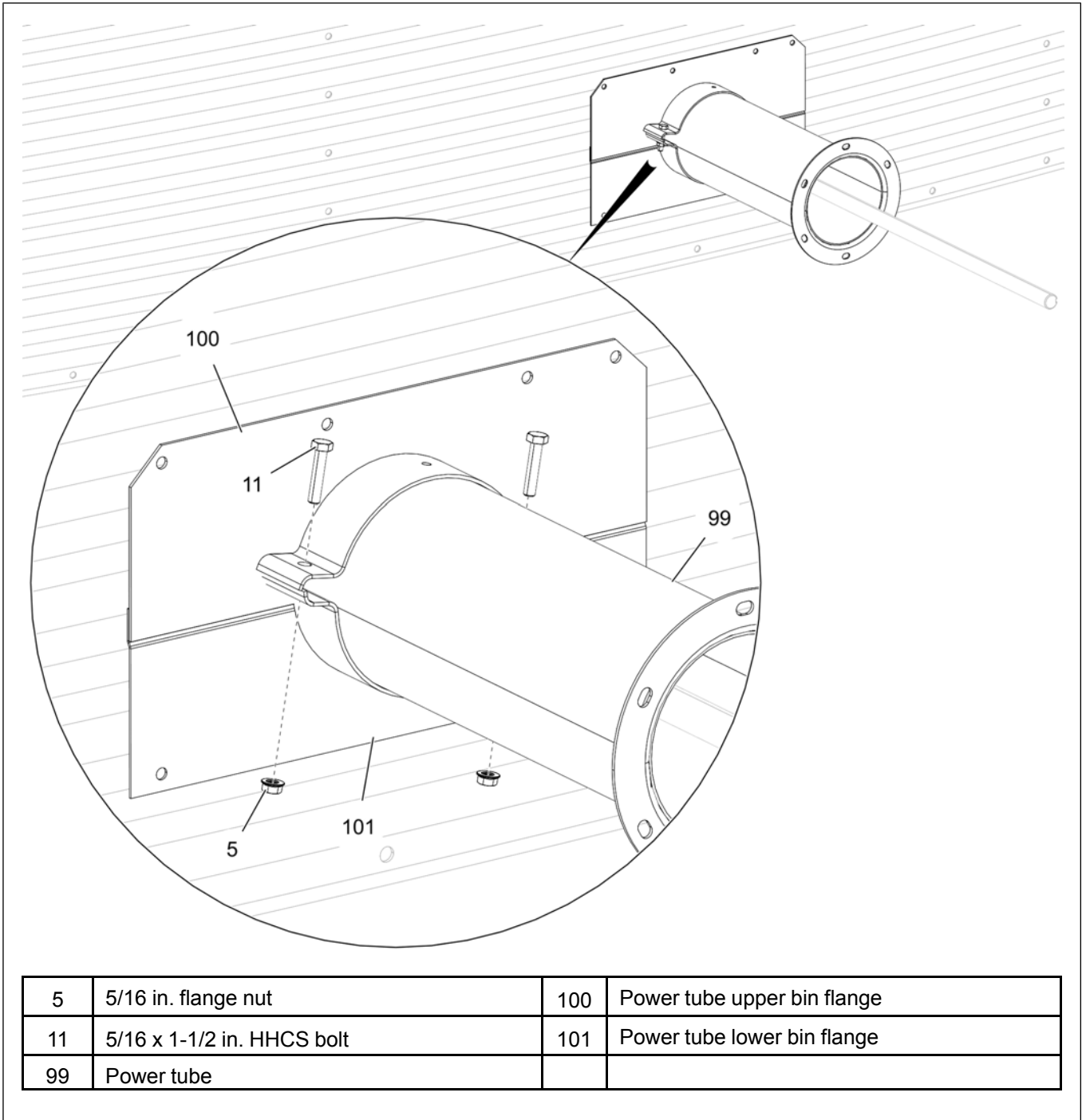
**Figure 3-60** *Installing the drive shaft to the center well drive coupler*



## Installing the Bin Flanges for Power tube

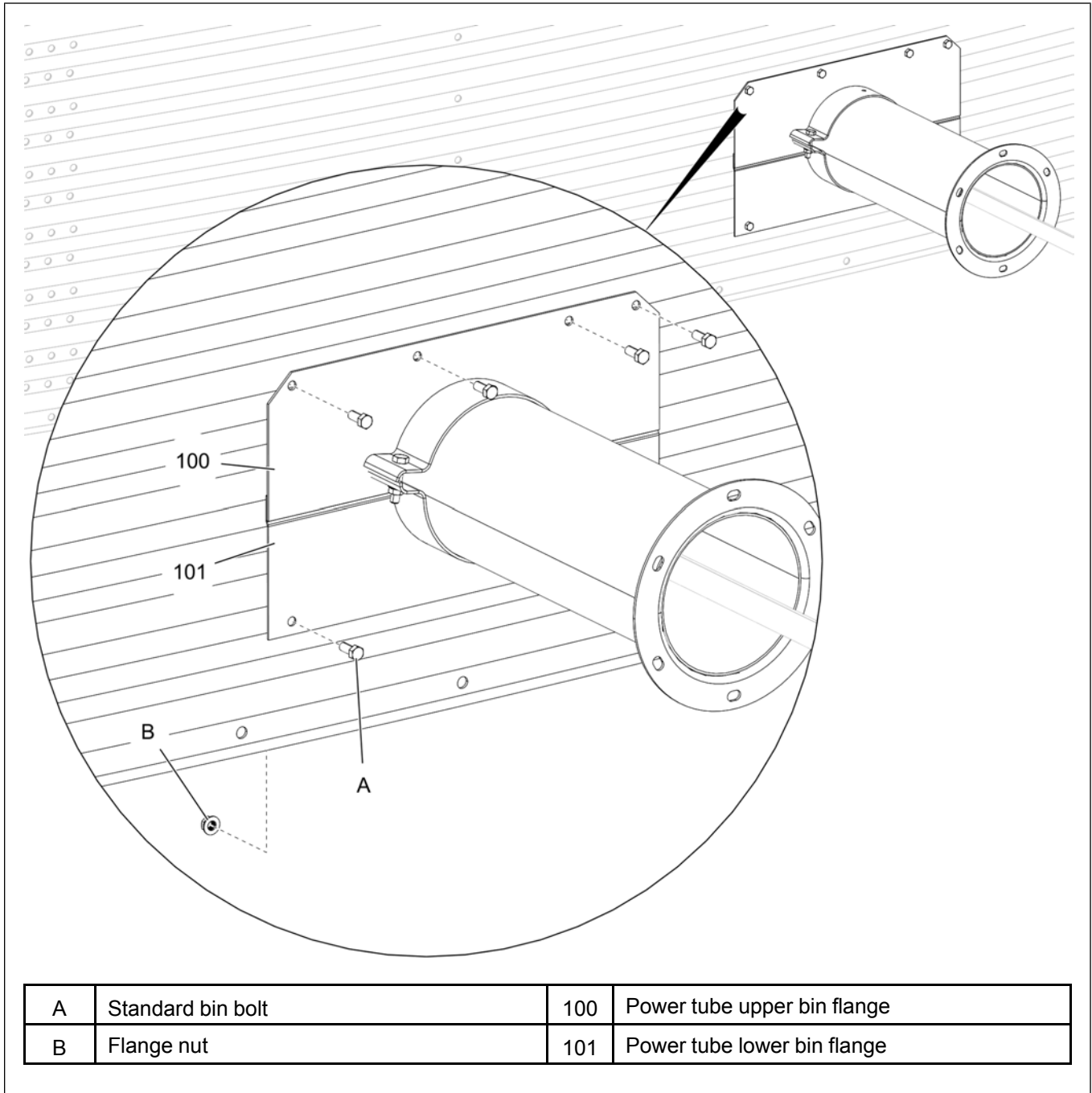
1. Attach the upper bin flange (100) and lower bin flange (101) loosely to the power tube (99) using 5/16 x 1-1/2 in. HHCS bolts (11) and 5/16 in. flange nuts (5).

Figure 3-61 Installing the upper and lower bin flanges for power tube



2. Slide the bin flanges flush with the bin wall and tighten the bolts connecting the two flanges.
3. Drill the holes in the bin wall through the four holes located in the upper bin flange (100) and two holes located in the lower bin flange (101) and secure the bin flanges to the bin wall using six standard bin bolts (A) and flange nuts (B).

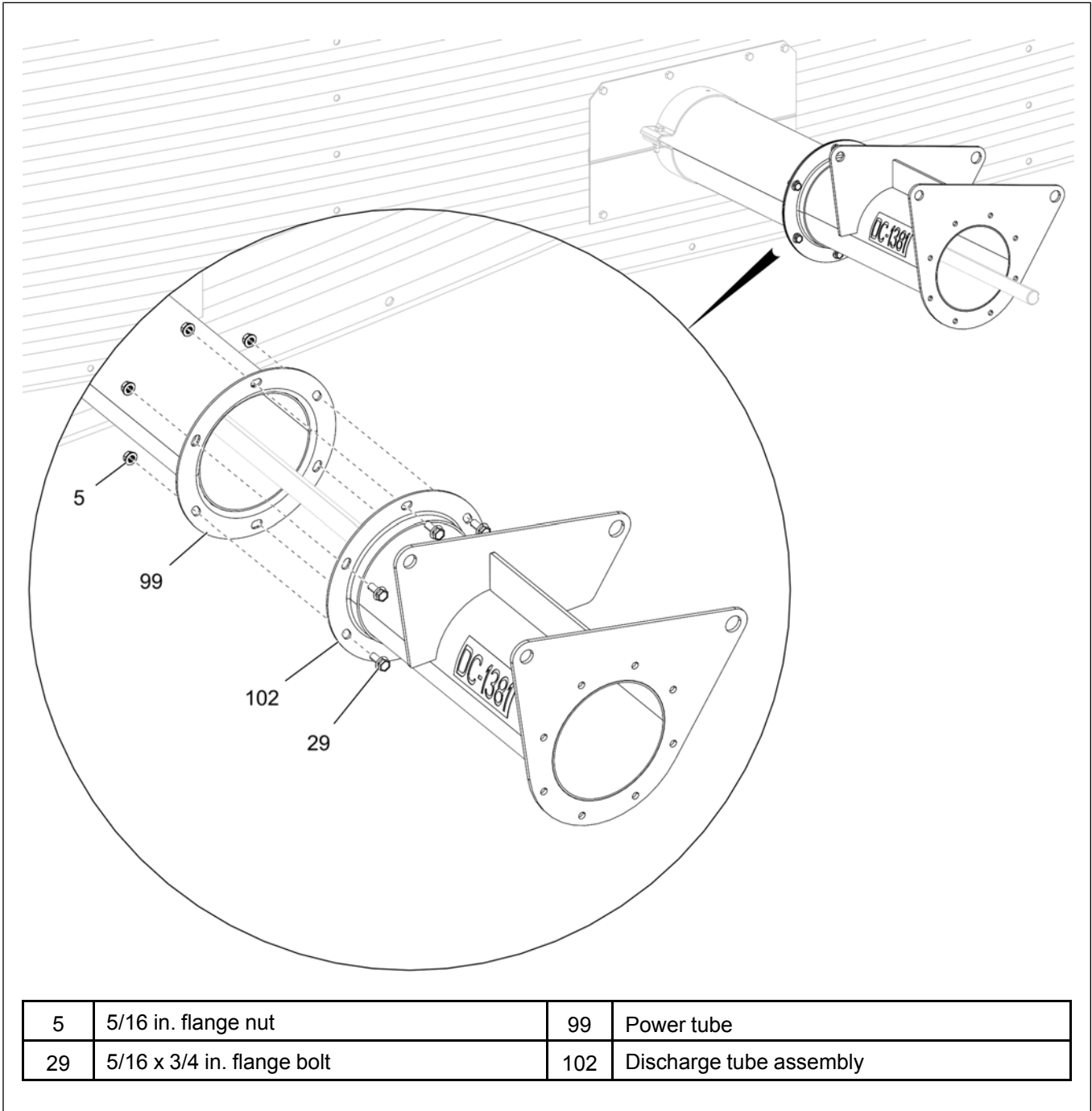
**Figure 3-62** *Secure the upper and lower bin flanges*



## Assembling the Drive Head

1. Align the flange of the power tube (99) with the flange of the drive tube assembly (102) and install using 5/16 x 3/4 in. flange bolts (29) and 5/16 in. flange nuts (5).

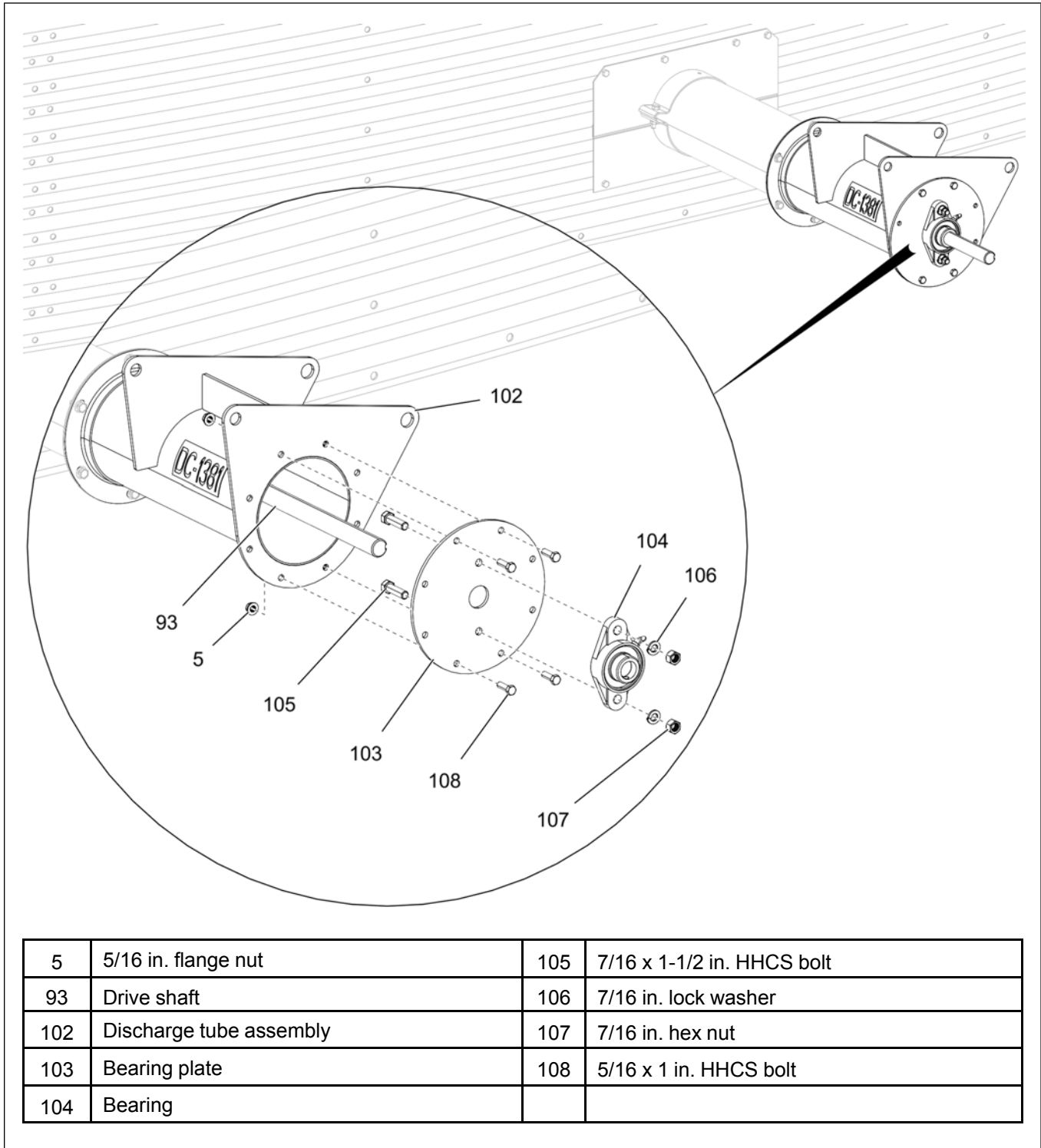
Figure 3-63 Attaching the power tube assembly to the drive head tube assembly





2. Install the bearing (104) to the bearing plate (103) using 7/16 x 1-1/2 in. HHCS bolts (105), 7/16 in. lock washers (106) and 7/16 in. hex nuts (107).
3. Slide the bearing plate assembly over the drive shaft (93) and attach it to the motor end of the tube assembly (102) using four 5/16 x 1 in. HHCS bolt (108) and four 5/16 in. flange nuts (5) as shown.

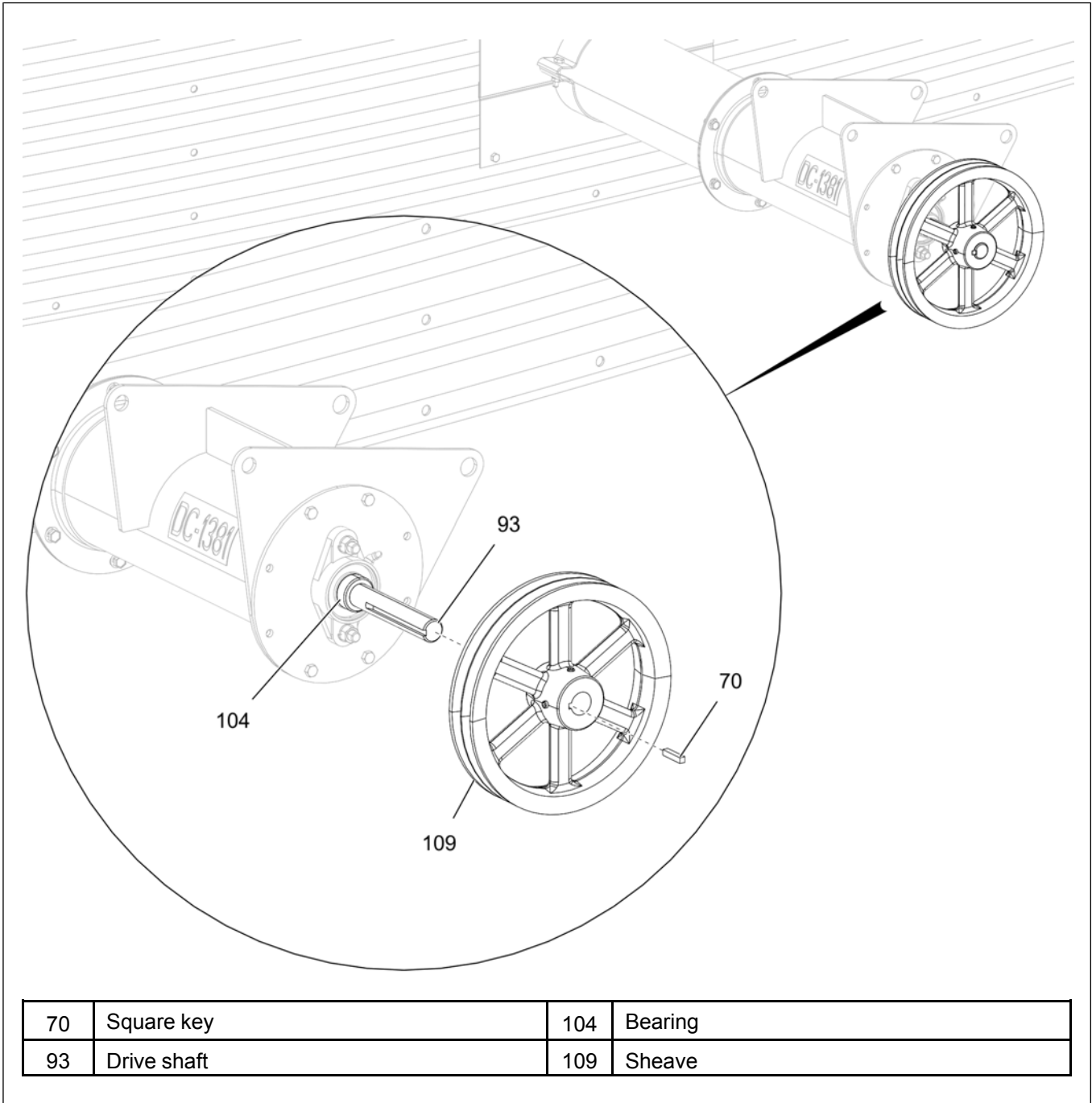
Figure 3-64 Assembling the bearing and bearing plate to the drive head tube



## Chapter 3: Installation

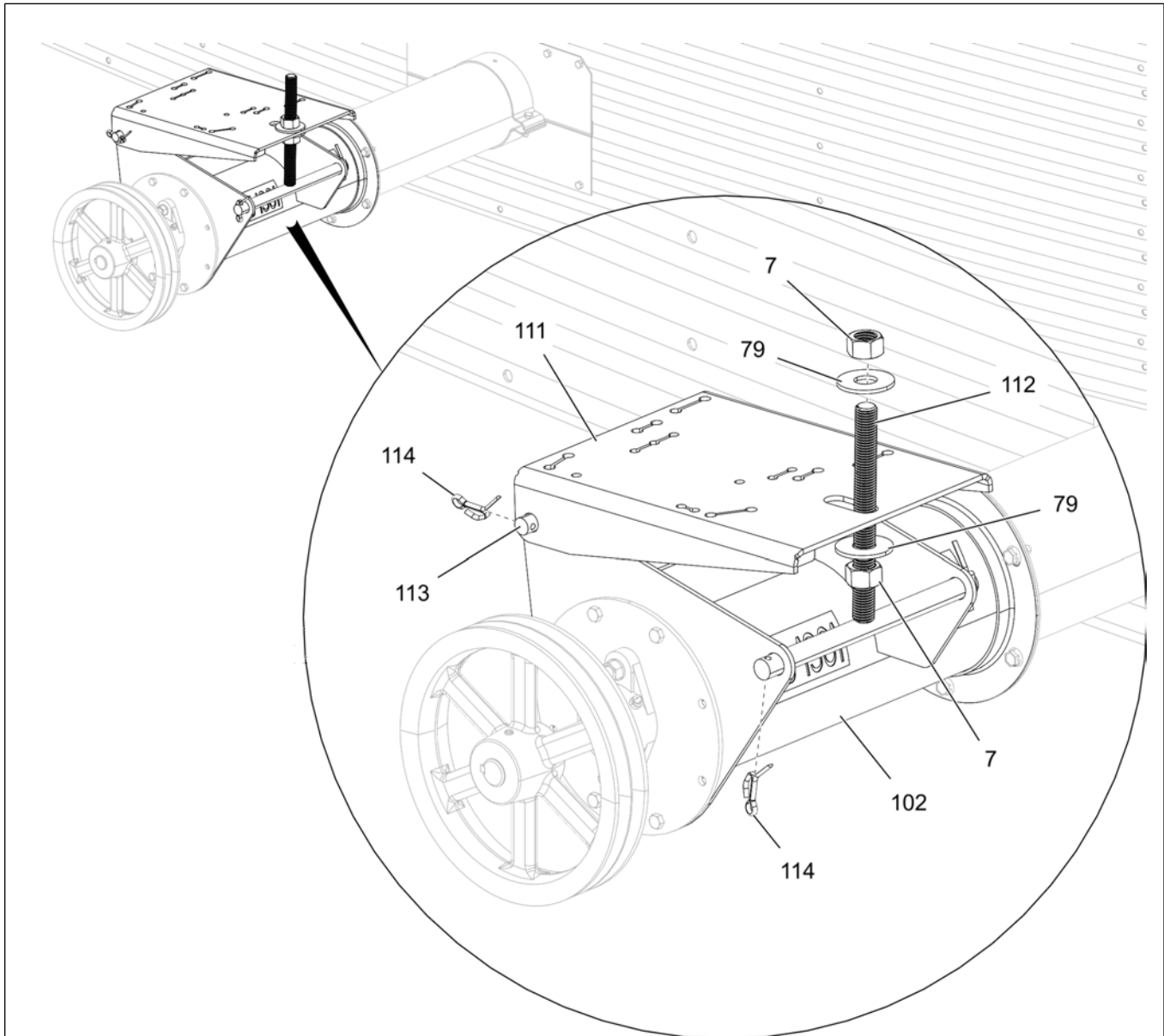
4. Install the bearing lock collar (104) over the drive shaft but DO NOT tighten the lock collar (104) at this time.
5. Slide the sheave (109) over the drive shaft (93) close to the bearing assembly. Once the sheave (109) is set at the correct position, secure the sheave (109) using the square key (70). Tighten the lock collar (104) on the bearing and then the set screws in the sheave (109).

**Figure 3-65** *Installing the sheave to the drive shaft*



6. Install the threaded weld rod (112) to the tube assembly (102) using cotter pins (114).
7. Install one end of motor mount plate (111) to the support plate of the tube assembly (102) using motor mount pivot rod (113) and cotter pins (114).
8. Install the other end of the motor mount plate (111) to the threaded weld rod (112) with 3/4 in. flat washers (79) and 3/4 in. hex nuts (7). This rod allows for the adjustment of the motor mount plate (111).

Figure 3-66 Installing the motor mount plate

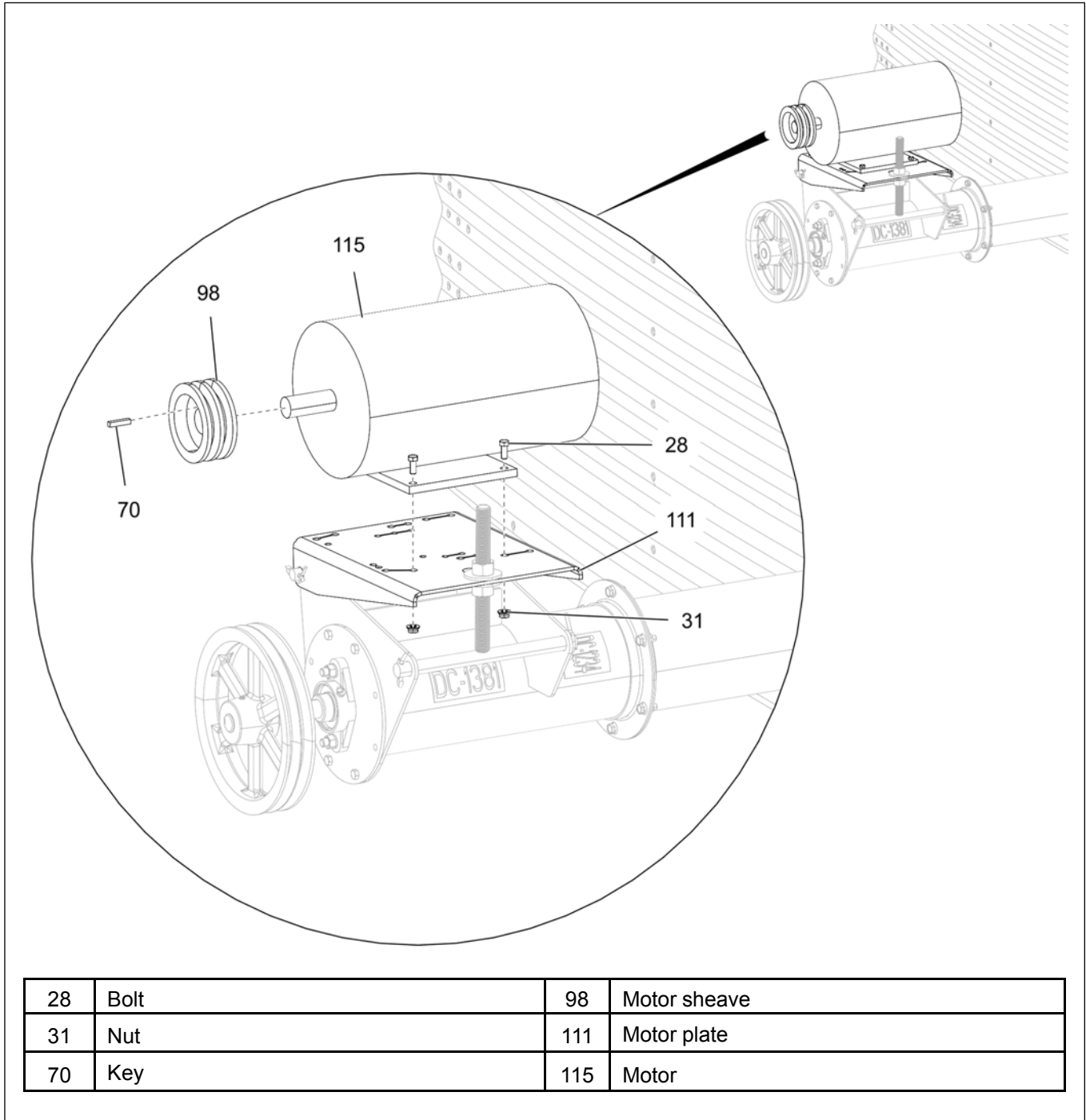


7	3/4 in. hex nut	112	Adjustment weld rod
79	3/4 in. flat washer	113	Pivot rod
102	Discharge tube assembly	114	Cotter pin
111	Motor plate		

## Chapter 3: Installation

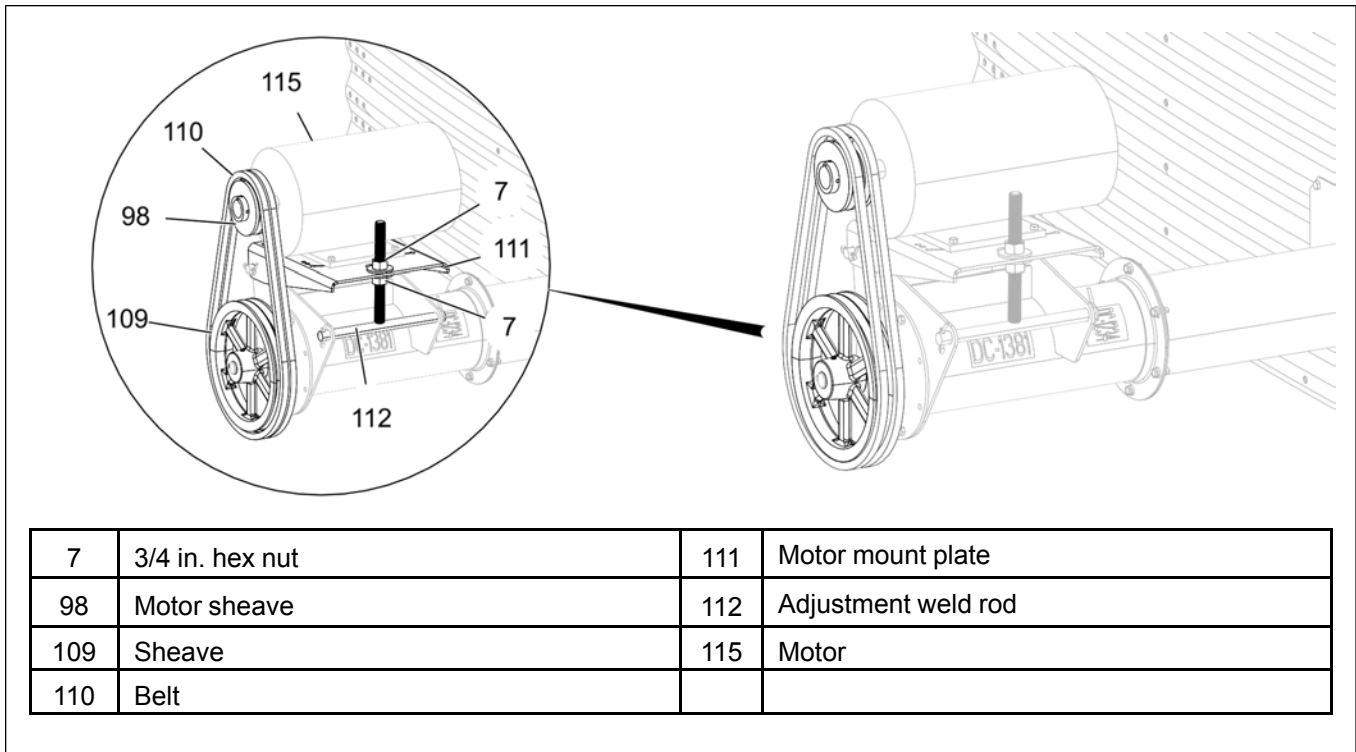
9. Install the motor sheave (98) to the motor shaft (115) using key (70).
10. Install the motor (115) along with pulley (98) to the motor mount plate (111) using bolts (28) and nuts (31).

Figure 3-67 Installing the motor



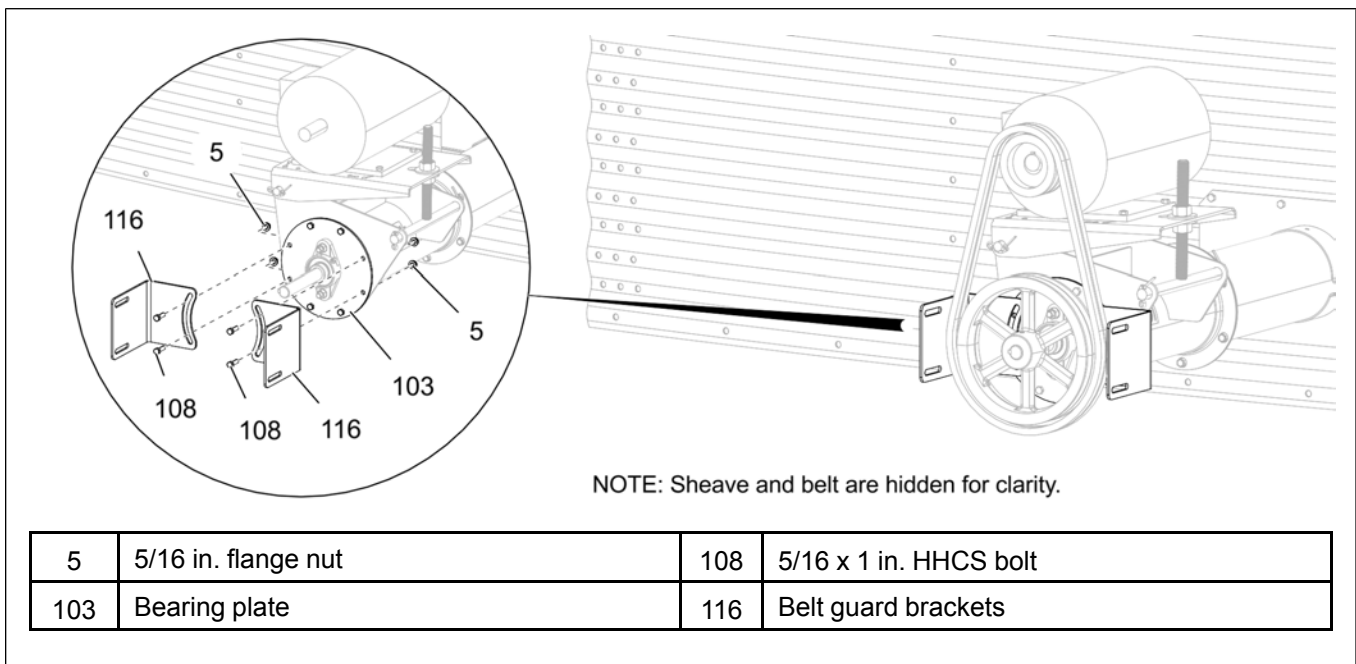
11. Untie and align the belts (110) to the sheaves (98 and 109) and tighten them by adjusting the nuts (7) of the weld rod (112) on the motor mount plate (111).

Figure 3-68 Installing the belt



12. Install the belt guard brackets (116) to the bearing plate assembly (103) using 5/16 x 1 in. HHCS bolt (108) and 5/16 in. flange nuts (5).

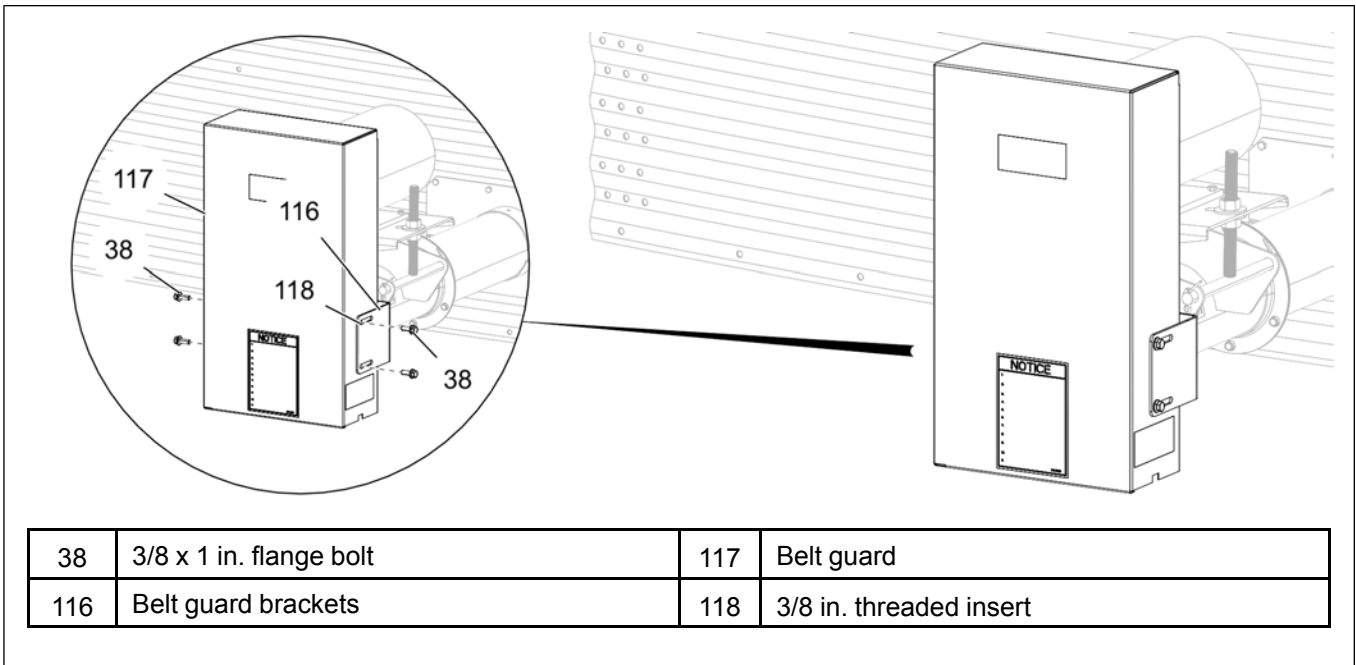
Figure 3-69 Installing the belt guard brackets



## Chapter 3: Installation

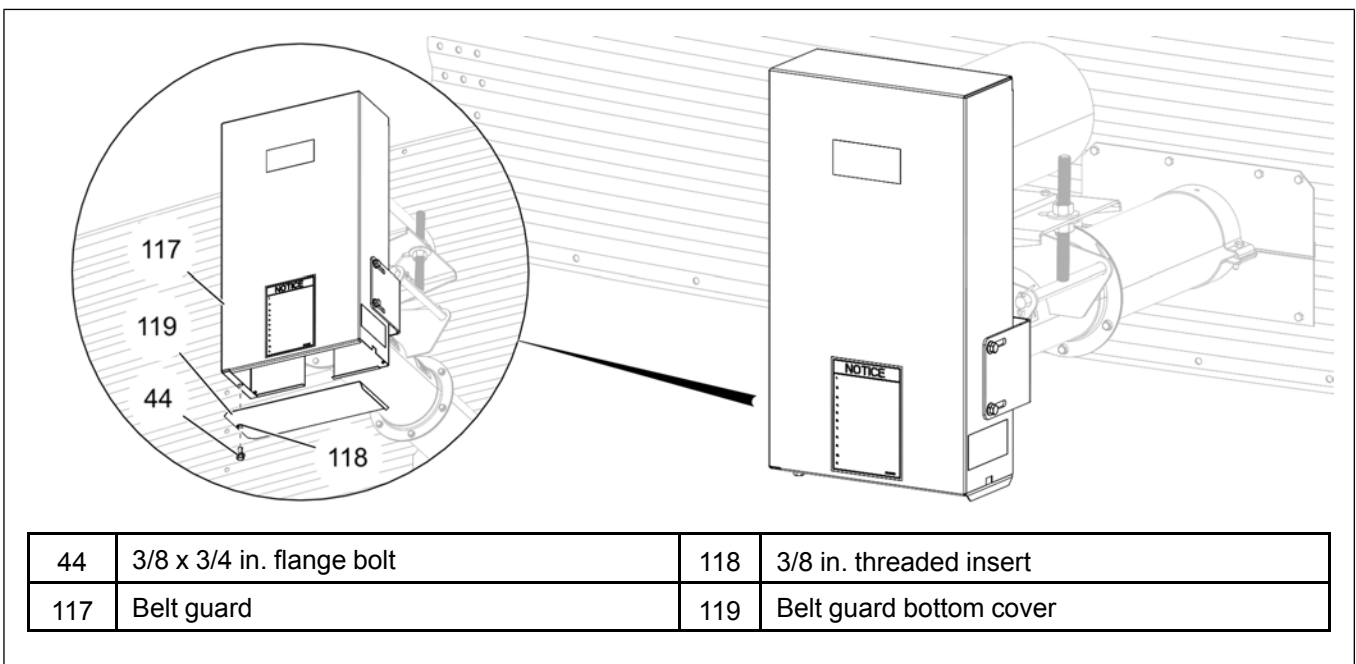
13. Assemble the belt guard (117) to the belt guard brackets (116) using 3/8 x 1 in. flange bolts (38) and 3/8 in. threaded insert (118).

**Figure 3-70** *Installing the belt guard*



14. Slide the belt guard bottom cover (119) into the belt guard (117) and install using 3/8 x 3/4 in. flange bolt (44) and 3/8 in. threaded insert (118).

**Figure 3-71** *Installing the belt guard bottom cover*



# 4 Operation

## Topics Covered in this Chapter

- Power Recommendations
- Before Filling the Bin
- Performing Pre–Start Checks
- Operating the Auger
- Final Clean Out

## Power Recommendations

1. The horsepower recommendations are to auger reasonably dry grain. High moisture grain above (15%) will require greater power if maximum capacity is to be maintained. The maximum possible capacity will be less with high moisture grain than with dry grain. Use the electric motor of the correct size that operates at 1750 RPM. DO NOT use a motor size that is greater than what is shown for the largest bin size in the column.
2. Consideration should be given to the proper size auger for a batch drying or any intermittent type operations. When augers are stopped and restarted under full load, it may result in damage to the auger. Using a larger diameter auger and reducing its load level will be far better than subjecting a smaller diameter auger to big loads. If an auger is kept from absolute filling, it will make start-up easier and will convey more efficiently.

**NOTE:** *The auger capacity can fluctuate greatly under varying conditions. Moisture content, different commodities, amount of foreign matter and speeds all play a part in the performance of the auger. Twenty-five percent (25%) moisture may cut capacity by as much as forty percent (40%) under some conditions.*





**Electric motors and controls must be installed by a qualified electrician and must meet the standards set by the National Electrical Code and all local and state codes.**

**A main power disconnect switch capable of being locked only in the OFF position shall be provided. This shall be locked whenever work is being done on the auger.**



**A magnetic starter should be used to protect the motor when starting and stopping. It should stop the motor in case of power interruption, conductor fault, low voltage, circuit interruption or motor overload. Then the motor must be restarted manually.**

**Some motors have built-in thermal overload protection. If this type motor is used, use only those with a manual reset.**

**The motor starting controls must be located outside the bin. Locate the motor starting controls outside the bin but near the bin door so the operator has full view of the operation inside the bin.**

**Disconnect power before resetting motor overloads.**

**Reset and motor starting controls must be located so that the operator has full view of the entire operation.**

**Make certain electric motors are grounded.**

**Shut OFF power to adjust, service or clean.**

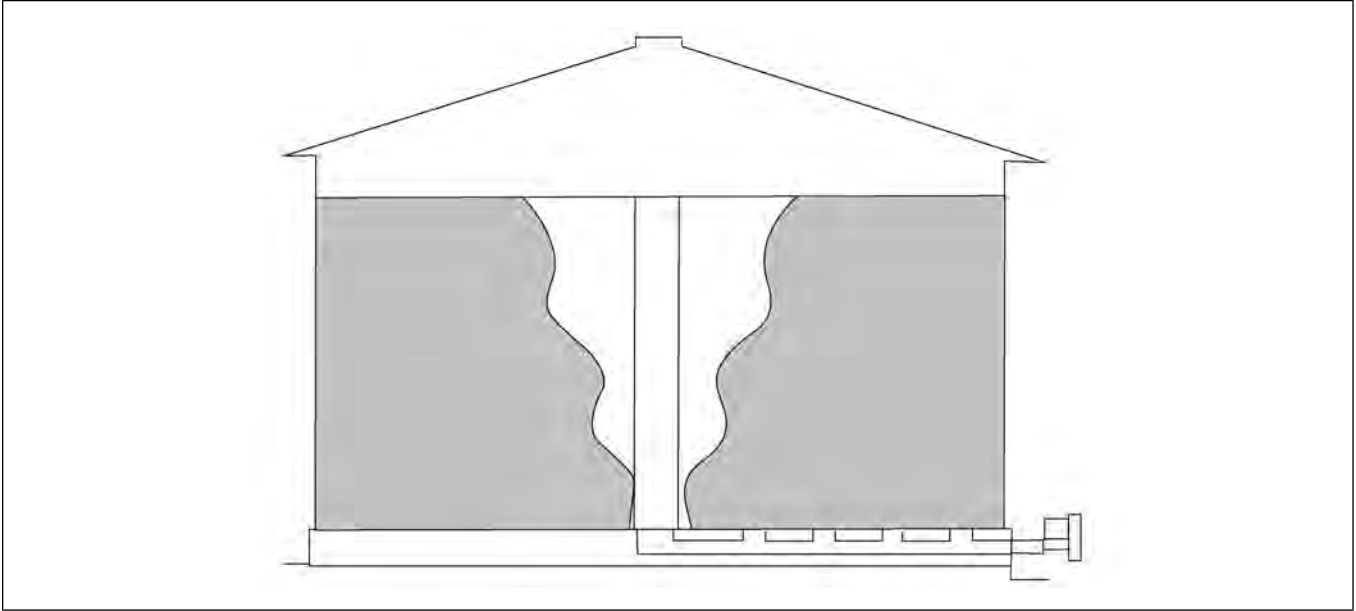
### Before Filling the Bin

1. Read the instructional decal located on the upper bin flange to learn how to control the power sweep well gates.
2. Close the center well and the intermediate well gates.
3. Position the sweep auger alongside of the intermediate wells.
4. Make sure the motor is off and the power source is locked out.

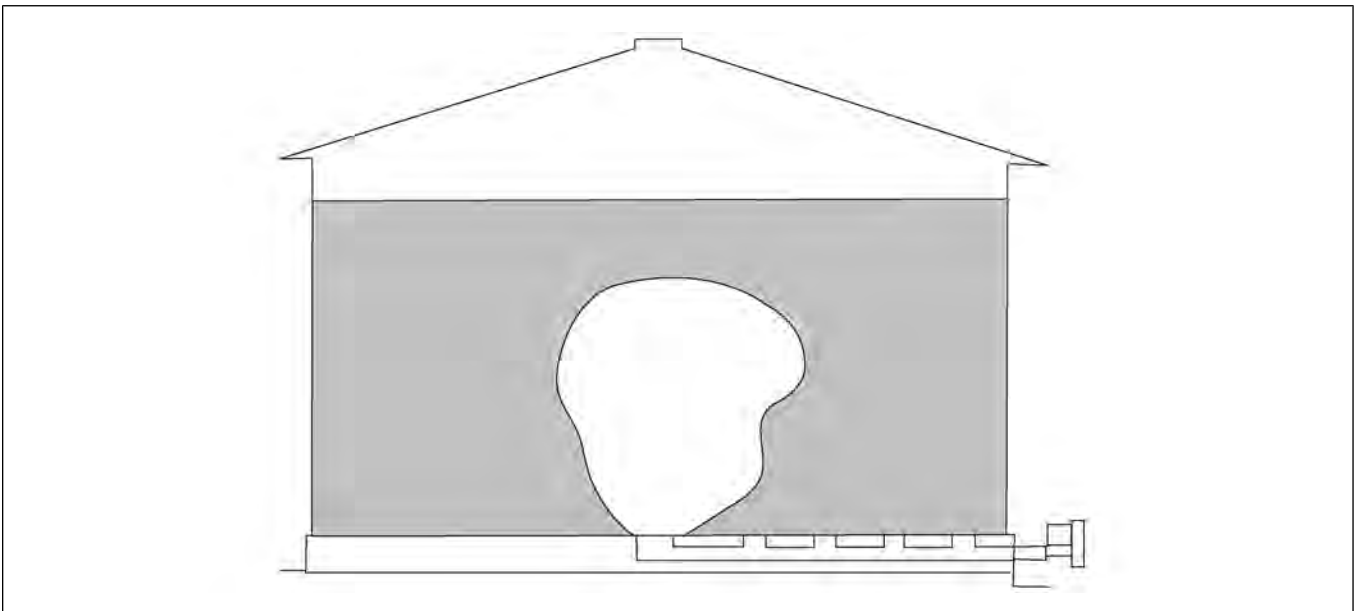


1. DO NOT enter the grain bin unless all power driven equipment has been shut down and locked out. Never enter the grain bin unless monitored by another person.
2. DO NOT enter the bin if the grain has bridged or has flowed abnormally out of the bin as shown. Suffocation can occur if grain suddenly breaks loose, burying persons who are inside the bin.



**Figure 4-1** *Abnormal grain flow*

Abnormal grain flow can easily fall and bury a person, suffocating them. DO NOT enter a bin with abnormal grain flow.

**Figure 4-2** *Bridged grain flow*

Bridged grain can easily break loose and bury a person, suffocating them. DO NOT enter a bin with bridged grain.

### Performing Pre-Start Checks



**Failure to perform any or all of these pre-start checks may cause damage to the equipment and/or cause *SERIOUS INJURY* or *DEATH* to those in the work area. Failure to perform any or all of these pre-start checks may also be a misuse of the equipment. Any misuse of the equipment may void the warranty.**

1. Make sure ALL belts are tensioned properly.
2. Make sure ALL shields are in place and that the belt(s) and pulley(s) are able to move freely.



***ALWAYS keep ALL guards and shields in place, until all the power is disconnected and locked out.***

3. Inspect the drive unit for any problems or potential problems.
4. Be aware of any emergency shut down procedures. Two people must always be in a position where the operation of the equipment can be monitored.
5. Before starting the auger for the first time, make sure that all parts are assembled correctly according to the instructions in this manual.



***Make certain ONLY trained operators are in the work area before operating or moving the machine. Two (2) people must always be in a position where the operation of the equipment can be monitored.***

## Operating the Auger



**DO NOT start/stop the auger while it is under load, this may cause the auger to “jam”.**



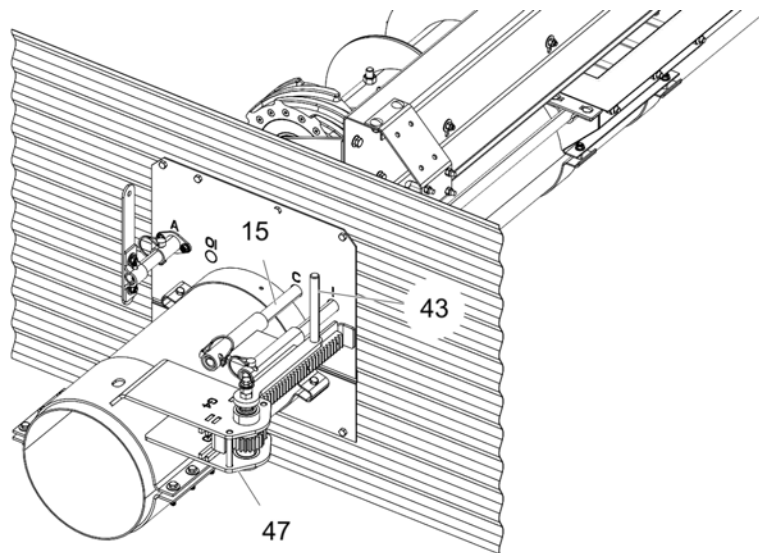
**Failures may occur if the auger is run full before it has been “polished” during the “break-in” period.**



**Be aware of any unusual vibration or noises during the initial start-up and “break-in” period. If anything unusual is detected, immediately shut down the auger and disconnect and lock out the power supply before servicing. Visually inspect the auger periodically during operation.**

1. Start the chain loop drive motor. To figure out the horsepower needed for the equipment, use the horsepower chart.
2. Make sure the lock pin is inserted through the rack and pinion tube (47) and center well control rod (15). Make sure the intermediate well control rod is not attached to the rack and pinion tube (47).

**Figure 4-3** Opening the center well gate



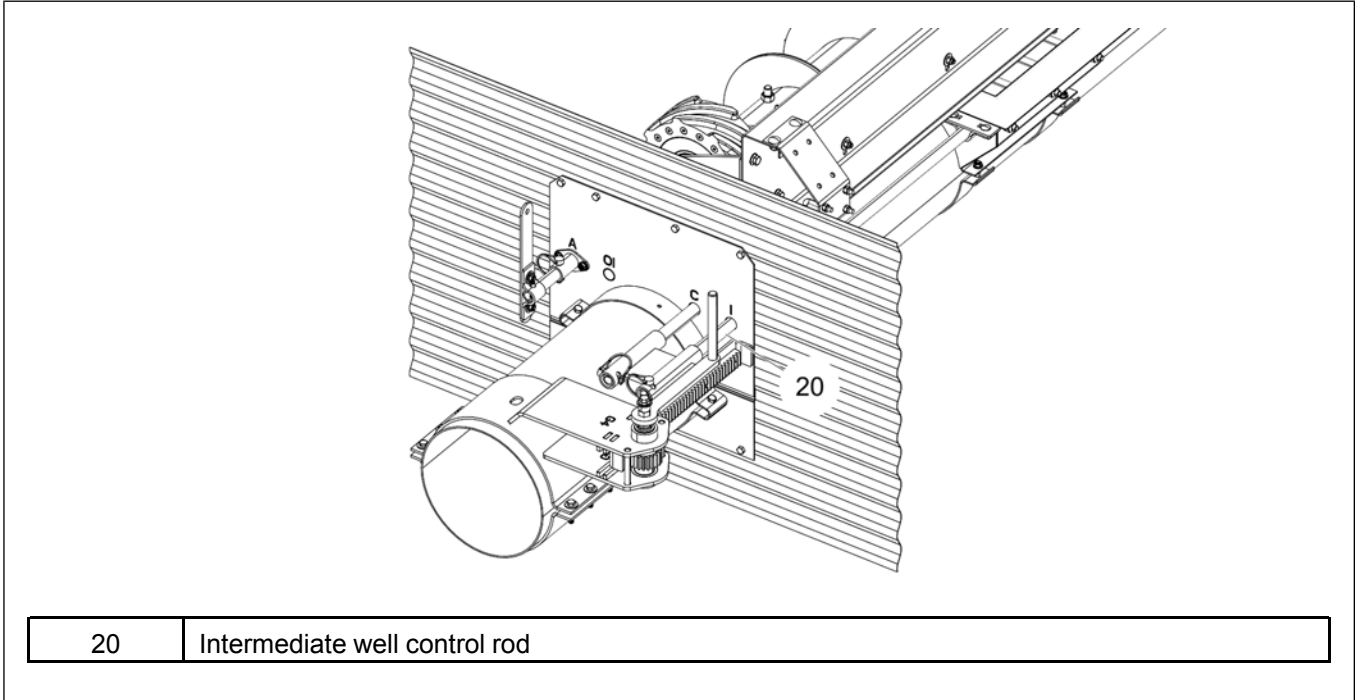
15	Center well control rod	43	Rack and pinion handle
47	Rack and pinion tube		

3. Using the handle (43) on rack and pinion, open center gate (indicated with “C”) until desired flow is established. It should not be necessary to open gate more than 3 in. to 6 in. Do not open the gate more than 3 in. to 6 in. as the flow of grain into the center well will be at a higher rate than what the unload system can remove. This will cause the chain loop system to plug or jam.
4. Always close the well gates and allow the unloader to clean out before stopping the unloader.

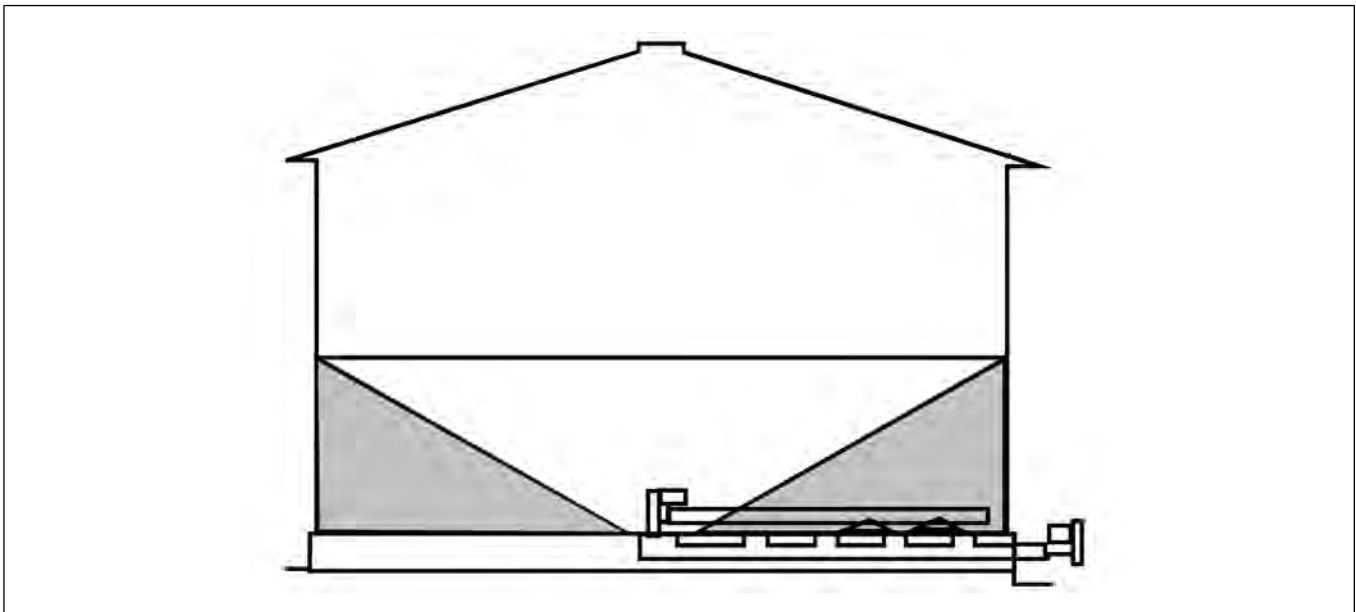
## Chapter 4: Operation

- When grain flow stops from the center well gate, close the center well gate and remove the pin. Insert the pin through the intermediate well control rod (20) (indicated with "I"). Remaining grain should look like as shown below.

**Figure 4-4** Intermediate well control rod



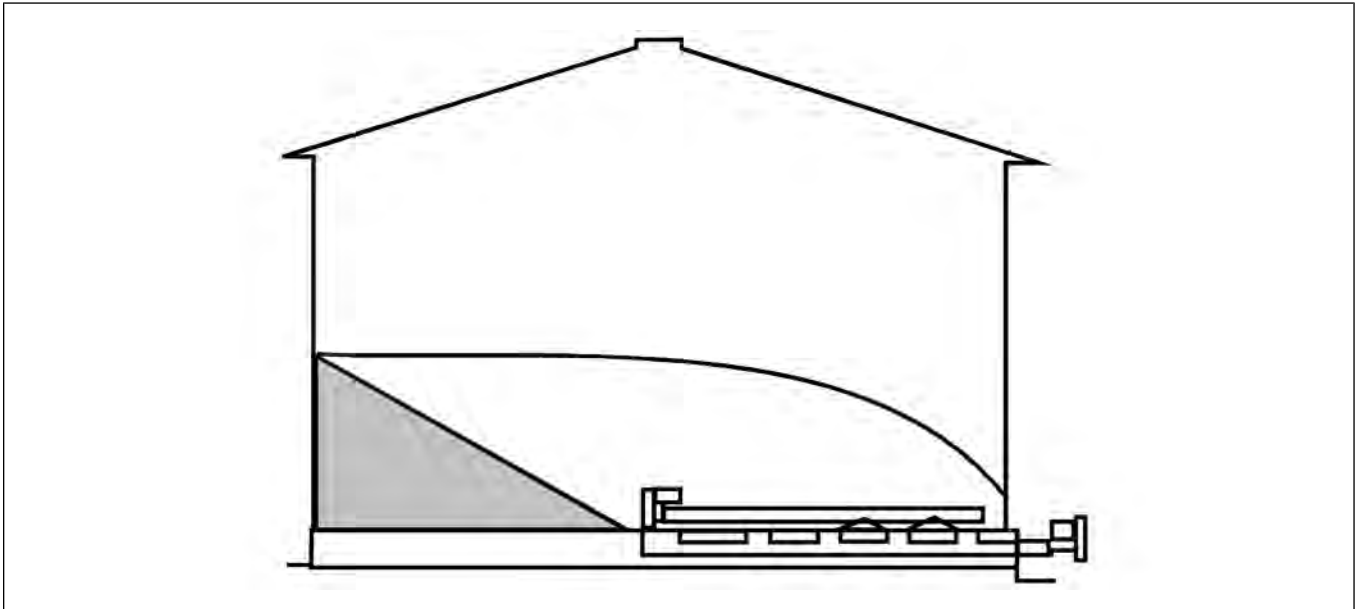
**Figure 4-5** Grain flow from the center well gate



6. Gradually open the gates until the desired flow of grain is reached. You should not open the gate more than 2 in. to 4 in. The remaining grain should look like as shown below.

**NOTE:** *If auxiliary well is installed, open it before opening intermediate gates.*

**Figure 4-6** Grain flow from the intermediate gates



### Final Clean Out

The following procedure is recommended for cleaning the floor of the bin after the sweep auger has removed as much grain as possible.



**Keep out of bin while sweep is in operation. Rapidly traveling sweep auger. The sweep auger will move rapidly around the bin when the bin is nearly empty.**



**Stay clear of the under floor unloader at the bin wells. The under floor unloader is exposed at these locations in the bin floor.**



**ALWAYS keep ALL guards and shields in place, until all the power is disconnected and locked out.**

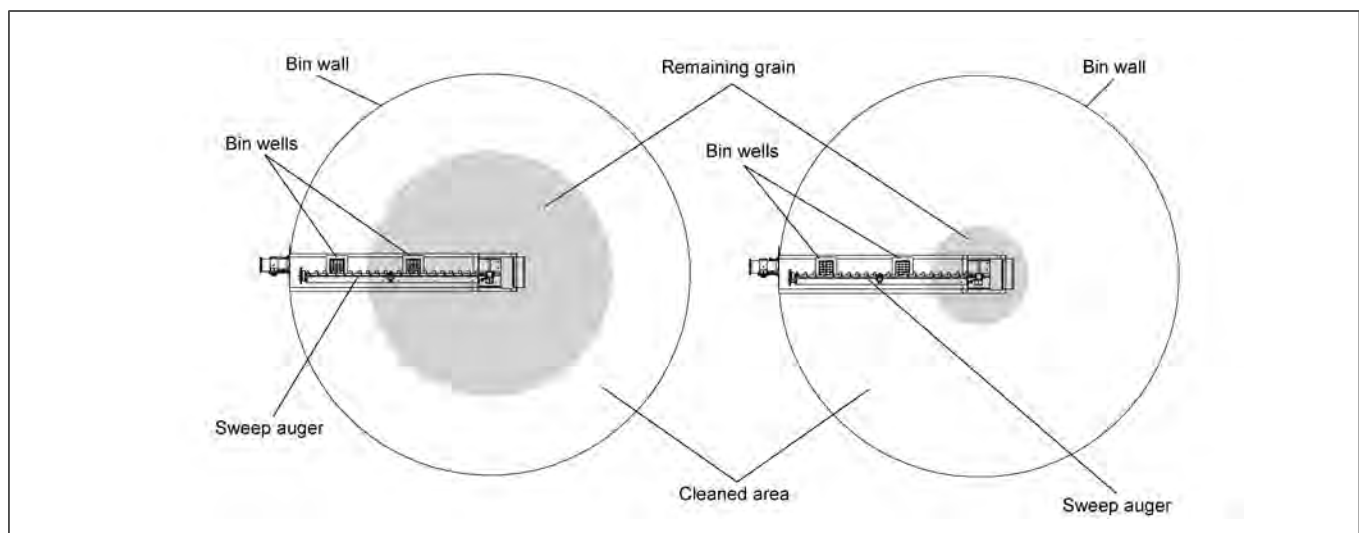
1. Clean (scoop and sweep by hand) the outer area of the floor into a circular pile towards the center of the bin.
2. Get out of the bin.
3. After making sure everyone is outside the bin and clear of the equipment, start the under floor unloader and the sweep auger. In a short time, the circular pile towards the center of the bin will have been removed.



**Stay clear of the under floor unloader at the bin wells. The under floor unloader is exposed at these locations in the bin floor.**

4. Scoop and sweep by hand the remaining floor area to the center of the bin.
5. Get out of the bin.
6. Repeat the above steps (step-3 to step-6) until all grain has been removed from the bin.

**Figure 4-7** *Cleaning the floor*



# 5 Shut Down

## Topics Covered in this Chapter

- Normal Shut Down
- Emergency Shut Down
- Storage Preparation

## Normal Shut Down

1. Before shutting down the unit, be sure the augers are empty.
2. Disconnect and lock out the power source before leaving the work area.

## Emergency Shut Down

1. Know how to shut down the auger in case of an emergency.
2. Do not restart the auger while it is under load.



***NEVER start the equipment under load. Doing so may cause damage. This type of damage is considered a misuse of the equipment. Any misuse of the equipment may void the warranty.***

3. Close the bin well control gates.
4. Reconnect and unlock the power source.
5. Clear the auger gradually, until there is no grain and there are no obstructions.

## Storage Preparation

1. Read the instructional decal located on the upper bin flange to learn how to control the power sweep well gates.
2. Close the center well and the intermediate well gates.
3. Position the sweep auger alongside of the intermediate wells.
4. Make sure the motor is off and the power source is locked out.
5. Be sure the unload tube is empty.
6. Shut down the auger.
7. Make sure all fasteners are tight.



***DO NOT enter the grain bin unless all power driven equipment has been shut down.***



---

# NOTES

# 6 Maintenance and Troubleshooting

## Topics Covered in this Chapter

- Maintaining the Auger
- Troubleshooting

## Maintaining the Auger

**IMPORTANT:** *For locations that will be operating, the sweep in temperatures colder than -5° Fahrenheit, the grease in both gearboxes should be removed and replaced with 80W90 gear oil (40 fluid oz. each).*



**Properly maintaining this equipment will help to ensure it continues to work properly. Failure to properly maintain this equipment may result in damage to the equipment or may cause *SERIOUS INJURY* or *DEATH* to the operator.**

***Failure to properly maintain this equipment may also be a misuse of the equipment. Any misuse of the equipment may void the warranty.***

1. The U-joint must be lubricated with SAE multipurpose grease every 10 operational hours or after each use.
2. The upper and lower gearboxes are grease filled and do not need operational maintenance. If repairing the gearboxes, it is recommended to fill them each with 40 fluid oz. of Mobilux EP 023 grease. If this grease is not used, 40 fluid oz. of SAE 80W90 gear oil is suggested.
3. Use caution when repairing or replacing equipment parts.
4. Make sure ALL decals are legible and tightly attached to the auger. If necessary, replace them **FREE OF CHARGE** by contacting the dealer, warehouse or the manufacturer.
5. Mount controls for any electric motors at a safe distance from the machine and in a location accessible in case of an emergency.
6. Make sure ALL electrical wiring is not damaged and that it meets proper wiring codes.
7. Make sure ALL components are in good working condition before use.

## Troubleshooting

Table 6-1 Troubleshooting guide

Problem	Possible Cause	Solution
Capacity is too low.	There may not be enough grain reaching the auger.	Make sure the intake has not bridged over, restricting flow. The flighting at the intake should be covered with grain for maximum capacity.
	The auger is moving too slowly.	Check the auger speed. Low capacity will result from speeds slower than recommended.
The sweep flight and shield are no longer moving.	Too much drag.	Check the clearance between the shield and the bin floor. Make sure there is room for the auger to move. Adjusting the shield may be necessary.
	Worn sweep wheel.	The sweep wheel wears down over time. Replace the wheel.
	Unconditioned grain.	Moisture and/or insects can cause the grain to harden or "Cake-up". Disconnect and lock out the power to the auger before going into the bin to correct this problem or to address any other problem.

# 7 Parts List

## Topics Covered in this Chapter

- Center Well
- Intermediate Well
- Outside Intermediate Well (For 42 ft and Larger Bins)
- Auxiliary Kits (Optional)
- Single Rack and Pinion (30 ft - 36 ft)
- Double Rack and Pinion (42 ft - 72 ft)
- Bin Flange
- Sweep Wheel
- Backshield with Two Augers (30 ft Bins)
- Backshield with Three Augers (33 ft - 42 ft Bins)
- Backshield with Four Augers (48 ft Bins)
- Backshield with Four Augers (54 ft Bins)
- Backshield with Five Augers (60 ft Bins)
- Backshield with Five Augers (66 Ft Bins)
- Backshield with Six Augers (72 ft Bins)
- Drive Head
- Backshield Connections

# Center Well

Figure 7-1 Center well parts

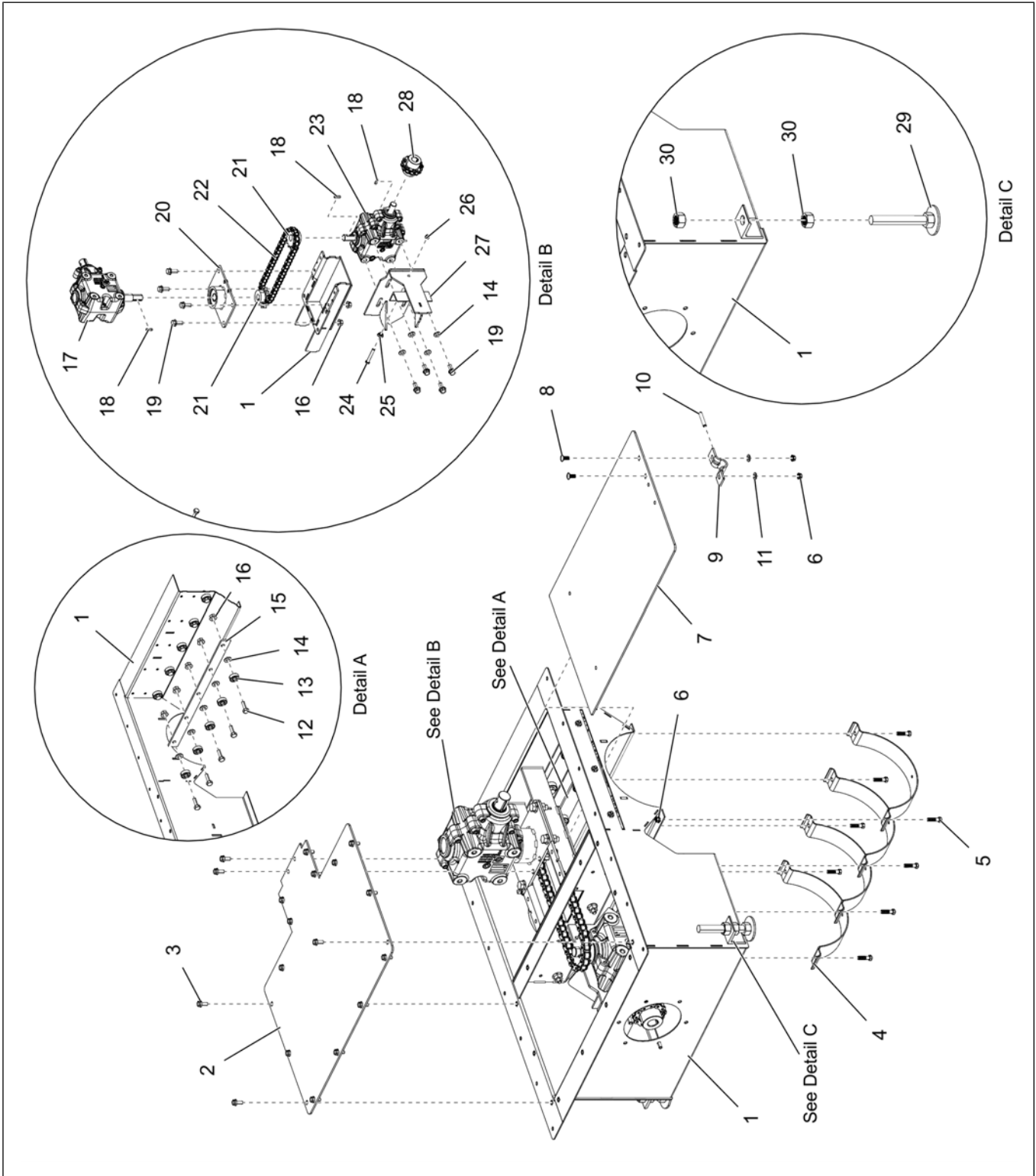


Table 7-1 Center well parts list

Ref #	Part #	Description
1	8101885-Y	Chain Loop DGD: Center Well Weldment Ochre - 8 in.
	8101676-Y	Chain Loop DGD: Center Well Weldment Ochre - 10 in.
	8120331-Y	Chain Loop DGD: Center Well Weldment Ochre - 12 in.
2	8101667	Chain Loop DGD: Center Well Plate Cover
3	S-6606	Bolt, Flange 5/16-18 x 3/4 in. ZN Clear Grade 5
4	GK1055	Band: Half 8 in. x 2 in. 12 Gauge Galvanized
	GK1057	Band: Half 10 in. x 2 in. 12 Gauge Galvanized
	GK1409	Band: Half 12 in. x 2 in. 12 Gauge Galvanized
5	S-9350	Bolt, HHCS 5/16-18 x 1-1/4 in. YDP Grade 8
6	S-3611	Nut, Flange 5/16-18 in. YDP Grade 2
7	8101689	Chain Loop DGD: Center Well Gate
8	S-6076	Bolt, Carriage 5/16-18 x 3/4 in. ZN Grade 2
9	GK1726	Clamp: Control Gate F/SSH 0.40 x 1/2 in.
10	S-8397	Pin, Spring 5/16 x 1-3/4 in. Plain Steel Slotted Rolled
11	S-1937	Washer, Flat 5/16 in. ZN SAE Grade 2
12	S-8760	Bolt, HHTB 1/2-13 x 1-1/2 in. ZN Grade 5
13	MHC01055	Bearing, Radial 1.375 OD, 0.50 ID
14	S-2120	Washer, Flat 1/2 in. SAE ZN
15	8101670	Chain Loop DGD: Center Well Gate Reinforcement Straps
16	S-8506	Nut, Flange 1/2-13 in. ZN
17	8101766	Gearbox, CGD Upper 1.35:1 Ratio, Extended Shaft
18	S-9168	Key, Square 1/4 in. x 1 in.
19	S-9062	Bolt, Flange 1/2-13 x 1-1/4 in. ZN Grade 5
20	8101715	Chain Loop DGD: Pivot Plate Assembly
21	AS-0920	Sprocket, #60 13T 1 in. Bore with Set Screws
22	8101726	Chain Loop DGD: Roller Chain #60, 47 Pitches
23	8101767	Gearbox, CGD Lower 1.25:1 Ratio
24	S-8132	Bolt, HHTB 3/8-16 x 3 in. ZN Grade 2
25	S-968	Nut, Flange 3/8-16 in. ZN Grade 5 Wide Flange
26	S-7383	Nut, Nylock 3/8-16 in. ZN Clear Grade 5
27	8101725	Chain Loop DGD: Gearbox Tension Angle IRN
28	8101901	Chain Loop DGD: Flex Coupler with Chain
29	C-7519	Leveling Leg
30	S-234	Nut, Hex 3/4-10 in. ZN Grade 5, Zinc Plated

## Intermediate Well

Figure 7-2 Intermediate well parts

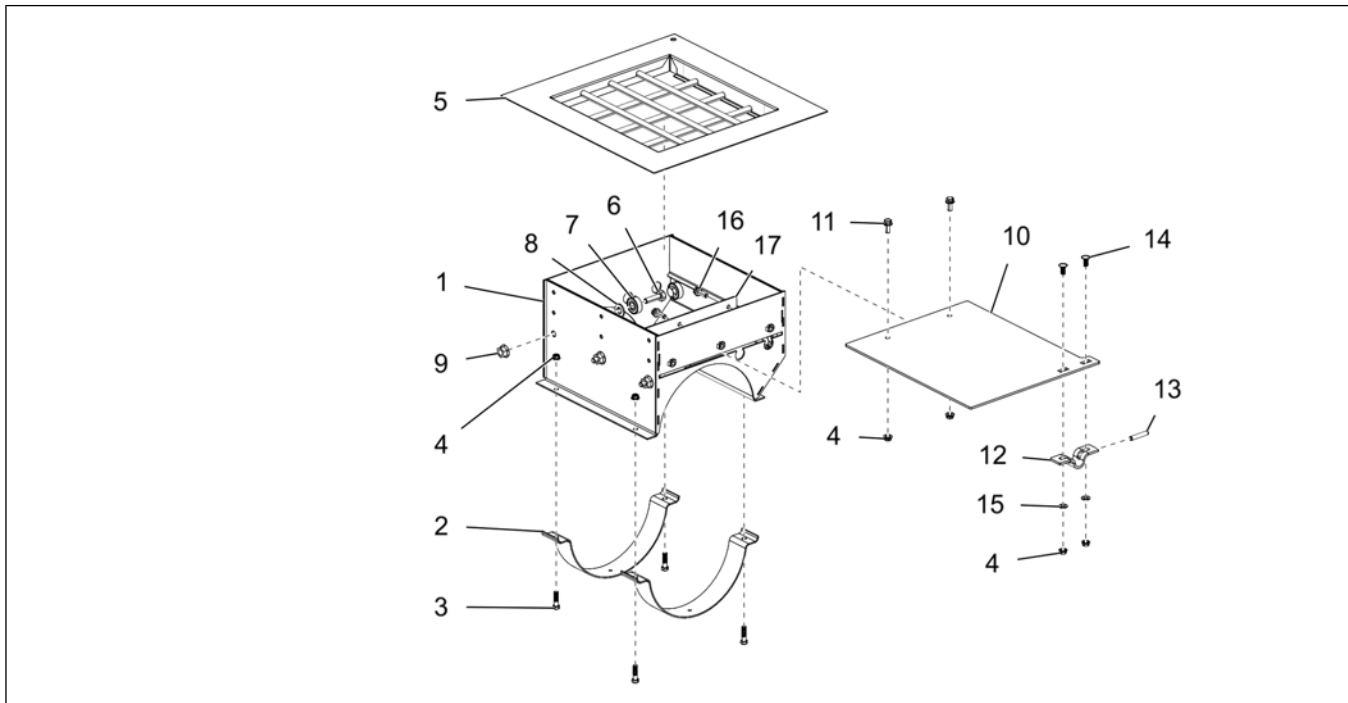


Table 7-2 Intermediate well parts list

Ref #	Part #	Description
1	8081392-Y	Chain Loop DGD: Intermediate Well Weldment, 2 Hole Ochre - 8 in.
	8101694-Y	Chain Loop DGD: Intermediate Well Weldment, 2 Hole Ochre - 10 in.
	8120339-Y	Chain Loop DGD: Intermediate Well Weldment, 2 Hole Ochre - 12 in
2	GK1055	Band: Half 8 in. x 2 in. 12 Gauge Galvanized
	GK1057	Band: Half 10 in. x 2 in. 12 Gauge Galvanized
	GK1409	Band: Half 12 in. x 2 in. 12 Gauge Galvanized
3	S-9350	Bolt, HHCS 5/16-18 x 1-1/4 in. YDP Grade 8
4	S-3611	Nut, Flange 5/16-18 in. YDP Grade 2
5	8101742-Y	Chain Loop DGD: Intermediate Well Top Flange Weld Assembly Ochre
6	S-8760	Bolt, HHTB 1/2-13 x 1-1/2 in. ZN Grade 5
7	MHC01055	Bearing, Radial 1.375 OD, 0.50 ID
8	S-2120	Washer, Flat 1/2 in. SAE ZN
9	S-8506	Nut, Flange 1/2-13 in. ZN
10	8101688	Chain Loop DGD: Intermediate Well Gate
11	S-6606	Bolt, Flange 5/16-18 x 3/4 in. ZN Clear Grade 5
12	GK1726	Clamp: Control Gate F/SSH 0.40 x 1/2 in.
13	S-8397	Pin, Spring 5/16 x 1-3/4 in. Plain Steel Slotted Rolled
14	S-6076	Bolt, Carriage 5/16-18 x 3/4 in. ZN Grade 2
15	S-1937	Washer, Flat 5/16 in. ZN SAE Grade 2
16	S-7470	Bolt, Flange 5/16-18 x 1 in. ZN Grade 5
17	8101675	Chain Loop DGD: Center Well Wiper Strap



## Outside Intermediate Well (For 42 ft and Larger Bins)

Figure 7-3 Outside intermediate well parts

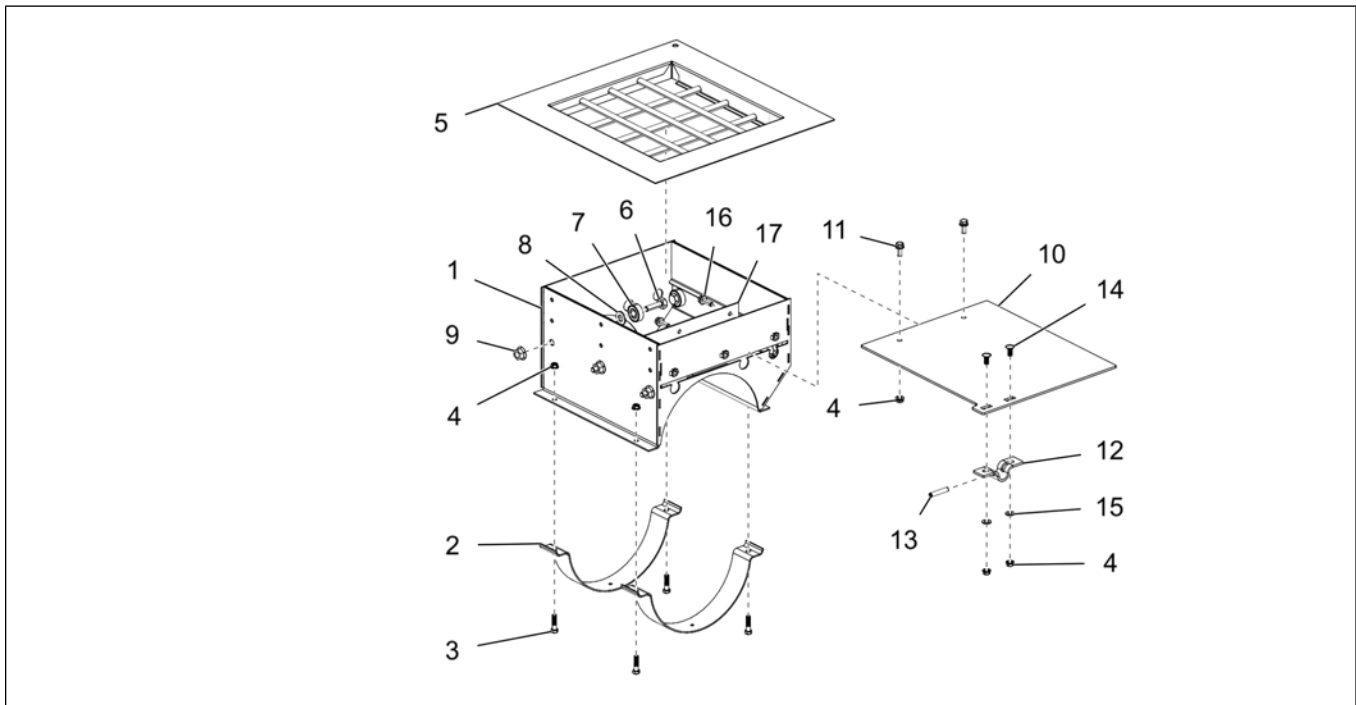


Table 7-3 Outside intermediate well parts list

Ref #	Part #	Description
1	8081400	Chain Loop DGD: Intermediate Well Weldment, 3 Hole Ochre - 8 in.
	8101693-Y	Chain Loop DGD: Intermediate Well Weldment, 3 Hole Ochre - 10 in.
	8120338-Y	Chain Loop DGD: Intermediate Well Weldment, 3 Hole Ochre - 12 in.
2	GK1055	Band: Half 8 in. x 2 in. 12 Gauge Galvanized
	GK1057	Band: Half 10 in. x 2 in. 12 Gauge Galvanized
	GK1409	Band: Half 12 in. x 2 in. 12 Gauge Galvanized
3	S-9350	Bolt, HHCS 5/16-18 x 1-1/4 in. YDP Grade 8
4	S-3611	Nut, Flange 5/16-18 in. YDP Grade 2
5	8101742-Y	Chain Loop DGD: Intermediate Well Top Flange Weld Assembly Ochre
6	S-8760	Bolt, HHTB 1/2-13 x 1-1/2 in. ZN Grade 5
7	MHC01055	Bearing, Radial 1.375 OD, 0.50 ID
8	S-2120	Washer, Flat 1/2 in. SAE ZN
9	S-8506	Nut, Flange 1/2-13 in. ZN
10	8101688	Chain Loop DGD: Intermediate Well Gate
11	S-6606	Bolt, Flange 5/16-18 x 3/4 in. ZN Clear Grade 5
12	GK1726	Clamp: Control Gate F/SSH 0.40 x 1/2 in.
13	S-8397	Pin, Spring 5/16 x 1-3/4 in. Plain Steel Slotted Rolled
14	S-6076	Bolt, Carriage 5/16-18 x 3/4 in. ZN Grade 2
15	S-1937	Washer, Flat 5/16 in. ZN SAE Grade 2
16	S-7470	Bolt, Flange 5/16-18 x 1 in. ZN Grade 5
17	8101675	Chain Loop DGD: Center Well Wiper Strap

## Auxiliary Kits (Optional)

Figure 7-4 Auxiliary kit parts (30 ft - 36 ft)

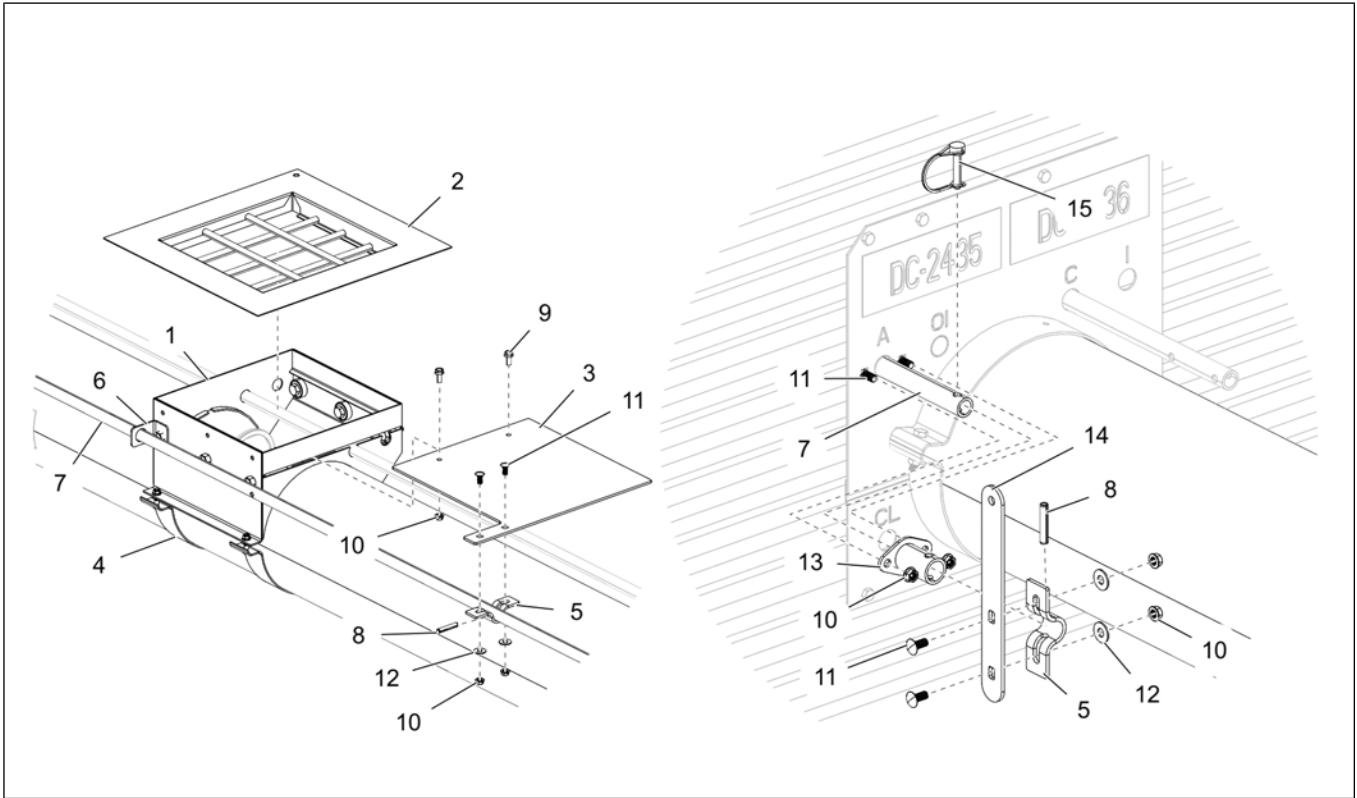


Figure 7-5 Auxiliary kit parts (42 ft - 48 ft)

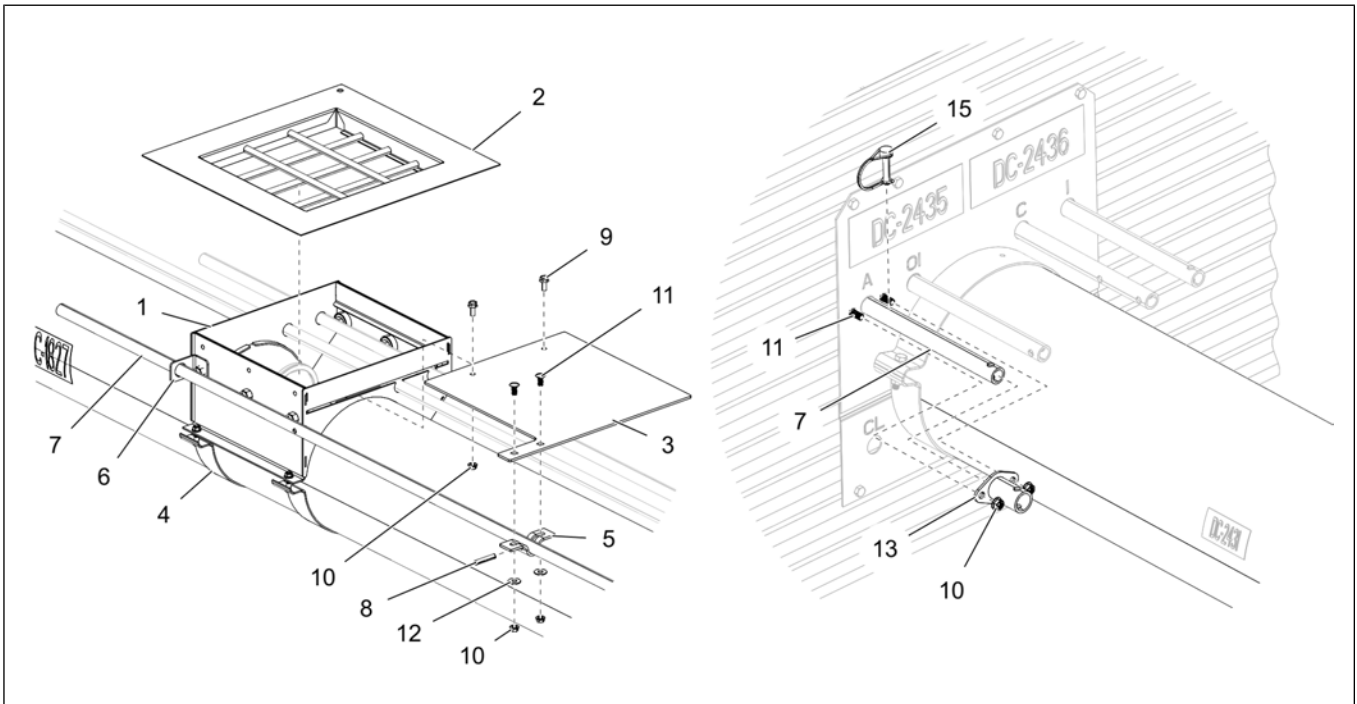


Table 7-4 Auxiliary kits parts list (30 ft - 48 ft)

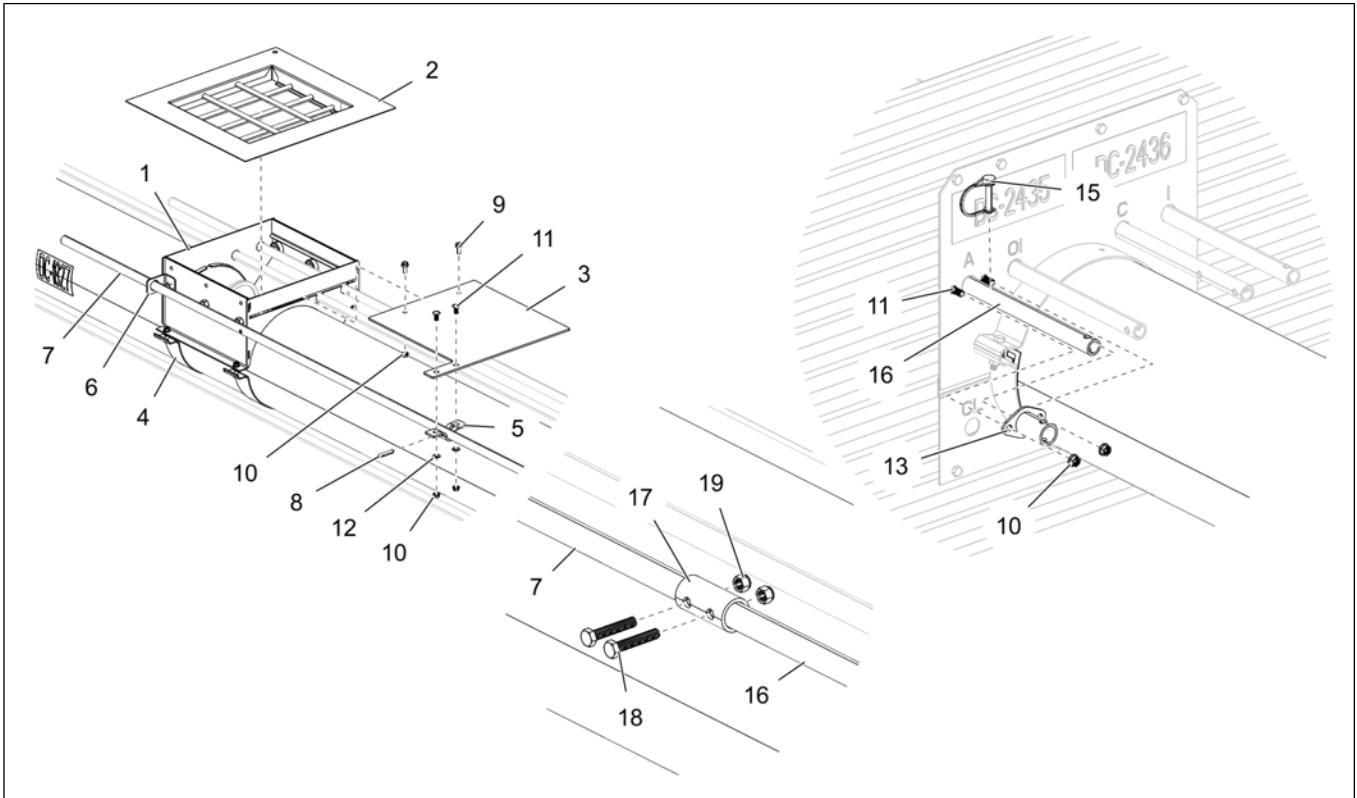
Ref #	Part #	Description
1	GK80554-Y	Intermediate Well Weldment Ochre
2	GK80561-Y	Intermediate Well Top Flange Ochre
3	GK80560	Auxiliary Well Gate - 10 in.
4	GK1055	Half Band, 8 in. x 2 in. 12 Gauge Galvanized
	GK1057	Half Band, 10 in. x 2 in. 12 Gauge Galvanized
	GK1409	Half Band, 12 in. x 2 in. 12 Gauge Galvanized
5	GK1726	Control Gate Clamp for SCH 40 x 1/2 in.
6	GK80559	Auxiliary Well Control Rod Guide
7	See table below	Auxiliary Well Control Rod
8	S-8397	5/16 x 1-3/4 in. Spring Pin
9	S-6606	5/16 x 3/4 in. Flange Bolt
10	S-3611	5/16 in. Flange Nut
11	S-6076	5/16 x 3/4 in. Carriage Bolt
12	S-1937	5/16 In. Flat Washer SAE
13	GK80613-BS	Auxiliary Well Lock Collar
14	GC12074	Auxiliary Clutch Control Rod Handle
15	S-10547	5/16 x 1-3/8 in. Safety Snap Pin

Table 7-5 Auxiliary well control rod parts list

Ref #	Part #	Description
7	GK80633	Auxiliary Well Control Rod - 30 ft.
	GK80634	Auxiliary Well Control Rod - 33 ft.
	GK80635	Auxiliary Well Control Rod - 36 ft.
	GK80752	Auxiliary Well Control Rod - 42 ft.
	GK80753	Auxiliary Well Control Rod - 48 ft.

# Chapter 7: Parts List

Figure 7-6 10 in. Auxiliary kit parts (54 ft - 72 ft)



**Table 7-6** Auxiliary kits parts list (54 ft - 72 ft)

Ref #	Part #	Description
1	GK80554-Y	Intermediate Well Weldment Ochre
2	GK80561-Y	Intermediate Well Top Flange Ochre
3	GK80560	Auxiliary Well Gate - 10 in.
4	GK1055	Half Band, 8 in. x 2 in. 12 Gauge Galvanized
	GK1057	Half Band, 10 in. x 2 in. 12 Gauge Galvanized
	GK1409	Half Band, 12 in. x 2 in. 12 Gauge Galvanized
5	GK1726	Control Gate Clamp For SCH 40 x 1/2 In.
6	GK80559	Auxiliary Well Control Rod Guide
7	See table below	Auxiliary Well Control Rod
8	S-8397	5/16 x 1-3/4 in. Spring Pin
9	S-6606	5/16 x 3/4 in. Flange Bolt
10	S-3611	5/16 in. Flange Nut
11	S-6076	5/16 x 3/4 in. Carriage Bolt
12	S-1937	5/16 In. Flat Washer SAE
13	GK80613-BS	Auxiliary Well Lock Collar
15	S-10547	5/16 x 1-3/8 in. Safety Snap Pin
16	See table below	Auxiliary Well Control Rod Extension
17	GK80532-BS	Clutch Control Rod Coupling - Bin Silver
18	S-7149	5/16 x 1-3/4 in. HHTB Bolt
19	S-7382	5/16 in. Nylock Nut

**Table 7-7** Auxiliary well control rod parts list

Ref #	Bin Dia (Ft)	Part #	Description
7	54, 60	GK80761	Auxiliary Well Control Rod - 54 ft.
	66	GK80765	Clutch Control Rod Extension - 72 ft.
	72	GK80785	Auxiliary Well Control Rod - 66 ft.
16	54	GK80759	Intermediate Well Control Rod Extension IS - 54 ft.
	60	GK80777	Intermediate Well Control Rod Extension IS - 60 ft.
	66	GK80783	Intermediate Well Control Rod Extension IS - 66 ft.
	72	GK80793	Auxiliary Well Control Rod Extension - 72 ft.

## Single Rack and Pinion (30 ft - 36 ft)

Figure 7-7 Single rack and pinion parts - 10 in.

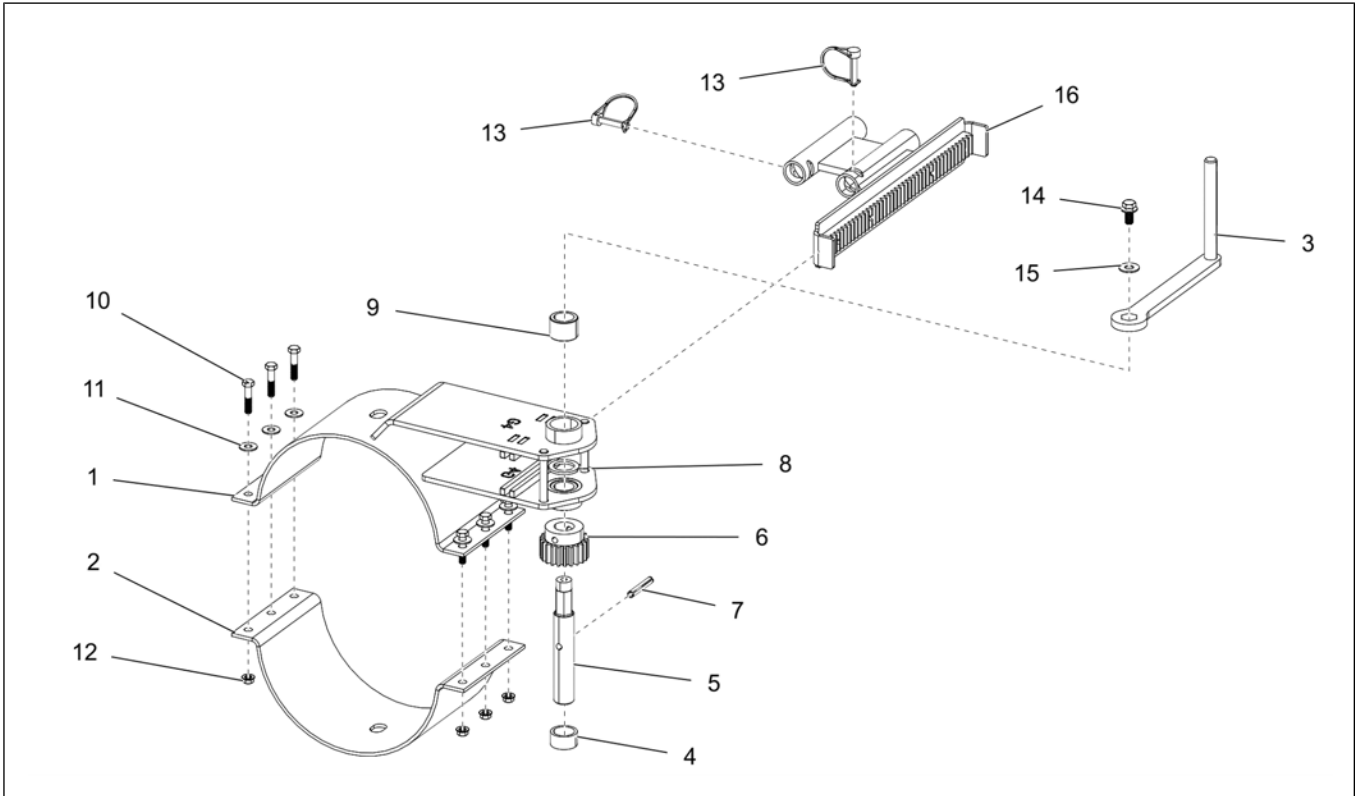


Table 7-8 Single rack and pinion (30 ft - 36 ft) parts list - 10 in.

Ref #	Part #	Description
1	GK80567-BS	Rack and Pinion Housing Weldment 10 in. Farm DGD - Bin Silver
2	GK1509-BS	Band: Half 10 in. x 6 in. 7 Gauge - Bin Silver
3	GK80404-BS	DGD Sweep Gate Crank Weldment, Painted
4	GK6841	Rack and Pinion Spacer Tube
5	GK6845	Rack and Pinion Crank Shaft Hex
6	GC09859	Gear, Spur 10 DP 14.5 PA 1 in. F x 22T Martin #S1022; 1 in. Bore with .313 Pin H
7	S-4377	Pin, Spring 5/16 x 2 in. Plain Steel Slotted Rolled
8	GK4211	Washer, Flat 1 x 1.1/2 in. 10 Gauge ZN
9	GK1070	Bushing Bronze 1.377 x 1.013 ID x 1 in. L GC09359 Machined To Specified ID
10	S-2741	Bolt, HHCS 5/16-18 x 1-1/2 in. ZN Grade 5
11	S-845	Washer, Flat 5/16 in. USS ZN
12	S-3611	Nut, Flange 5/16-18 in. YDP Grade 2
13	S-10547	Pin, Safety Snap 5/16 x 1-3/8 in. ZN C1008-C1010 Carbon Steel
14	S-9067	Bolt, Flange 3/8-16 x 3/4 in. ZN Grade 5
15	S-248	Washer, Flat 3/8 in. 7/16 in. ID 1 in. OD YDP
16	GK80568	Rack and Pinion Rack Bar Assembly 10 in. - Farm DGD

Figure 7-8 Single rack and pinion parts - 8 in. and 12 in.

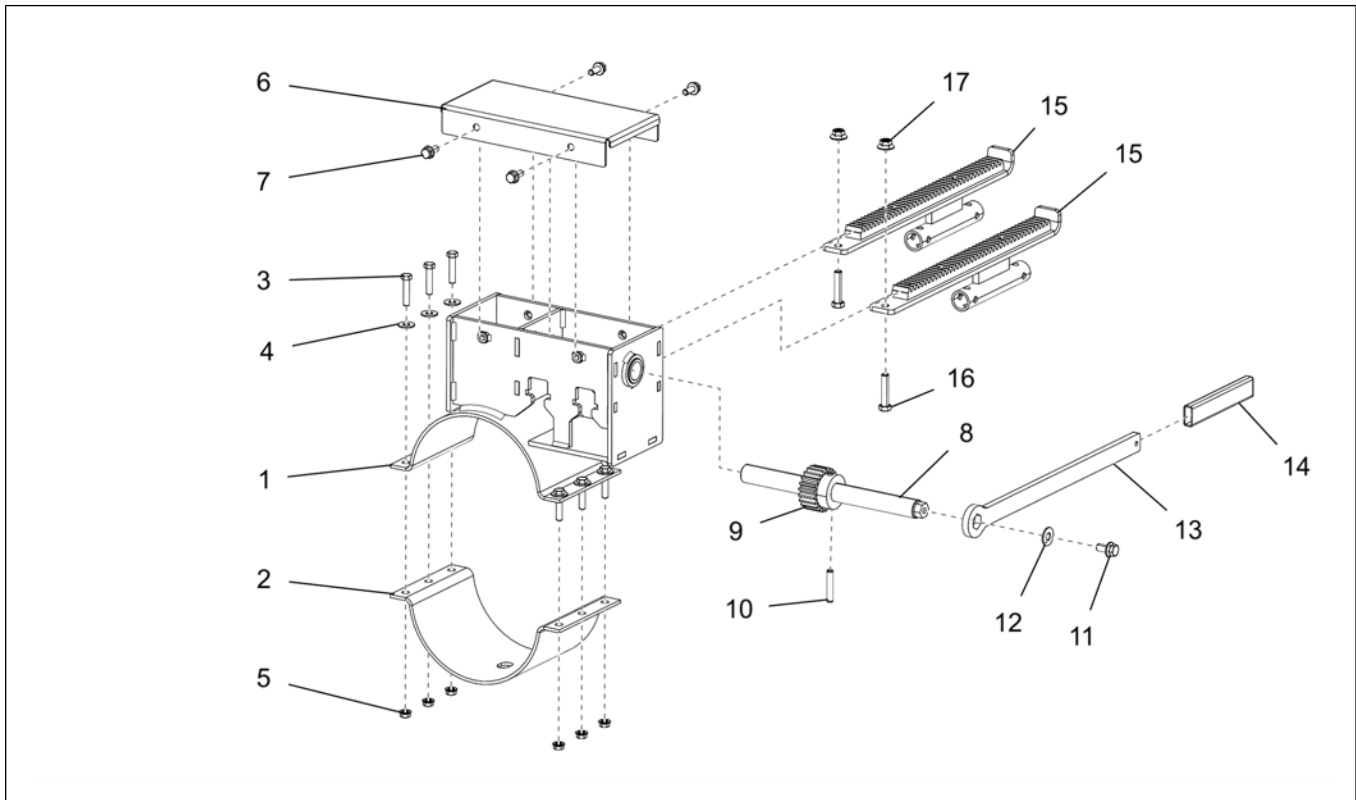


Table 7-9 Single rack and pinion (30 ft - 36 ft) parts list - 8 in. and 12 in.

Ref #	Part #	Description
1	GK81013	CGD Sweep: 8 in. Standard Rack and Pinion Housing Assembly
	GK81026	CGD Sweep: 12 in. Standard Rack and Pinion Housing Assembly
2	GK1326-BS	Band: Half 8 in. x 6 in. 7 Gauge - Bin Silver
	GC11749-BS	Band: Half 12 in. x 6 in. 7 Gauge - Bin Silver
3	S-2741	Bolt, HHCS 5/16-18 x 1-1/2 in. ZN Grade 5
4	S-845	Washer, Flat 5/16 in. USS ZN
5	S-3611	Nut, Flange 5/16-18 in. YDP Grade 2
6	GC20899	CGD Sweep: Standard Rack and Pinion Cover
7	S-6606	Bolt, Flange 5/16-18 x 3/4 in. ZN Clear Grade 5
8	GK81012	CGD Sweep: Rack and Pinion Shaft
9	GC09859	Gear, Spur 10 DP 14.5 PA 1 in. F x 22 T Martin
10	S-8397	Pin, Spring 5/16 x 1-3/4 in. Plain Steel SL
11	S-9067	Bolt, Flange 3/8-16 x 3/4 in. ZN Grade 5
12	S-248	Washer, Flat 3/8 in. 7/16 in. ID 1 in. OD YDP
13	GK7258	Wrench, 3/4 in. Hex, 16-7/8 in. Plated
14	GK7259	Cap, 0.368 x 0.970 x 6 - 701-UV-89-Black
15	GK80968	CGD Sweep: Rack and Pinion Rack Bar Assembly
16	S-8706	Bolt, HHTB 3/8-16 x 1-3/4 in. ZN Grade 5 Full
17	S-968	Nut, Flange 3/8-16 in. ZN Grade 5 Wide Flange



## Double Rack and Pinion (42 ft - 72 ft)

Figure 7-9 Double rack and pinion parts - 10 in.

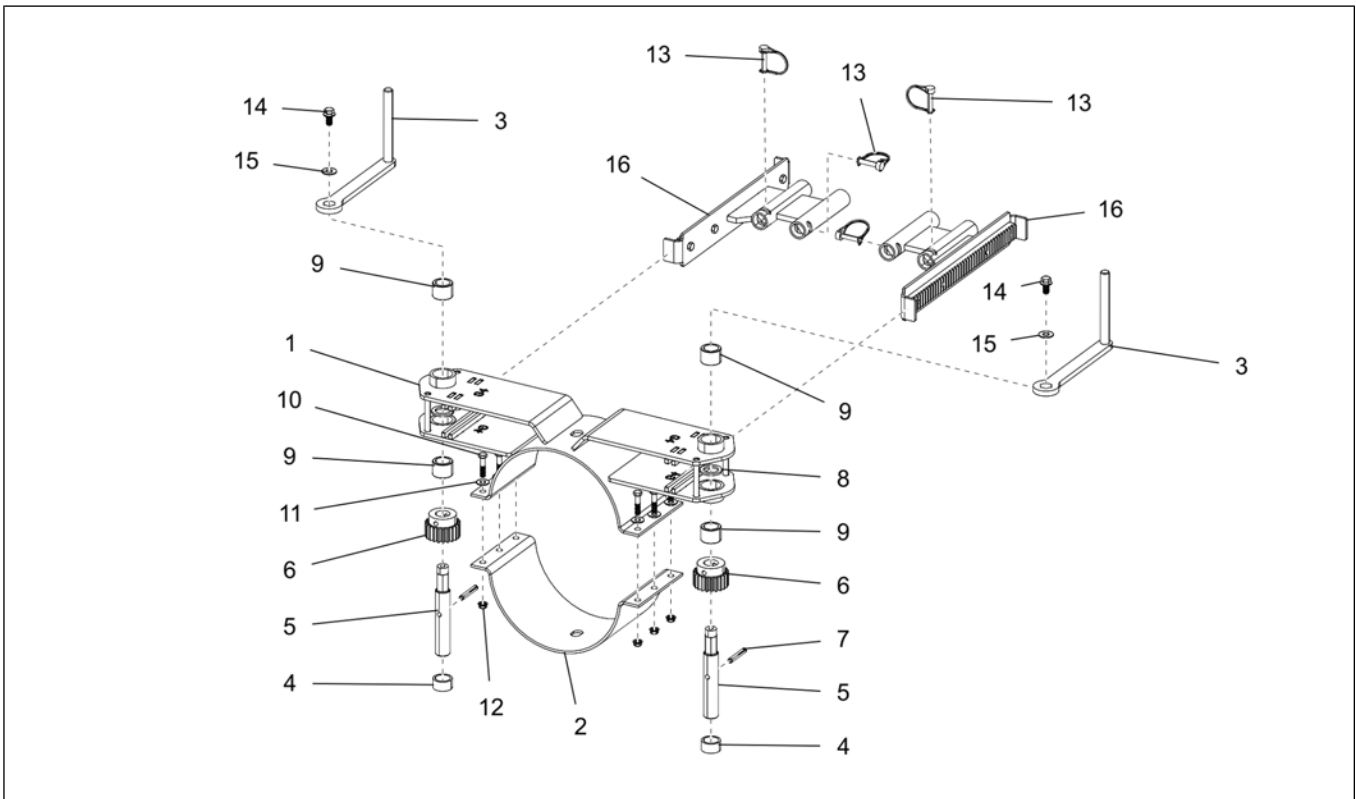


Table 7-10 Double rack and pinion (42 ft - 72 ft) parts list - 10 in.

Ref #	Part #	Description
1	GK80573-BS	Rack and Pinion Housing Weldment 10 in. Double DGD - Bin Silver
2	GK1509-BS	Band: Half 10 in. x 6 in. 7 Gauge - Bin Silver
3	GK80404-BS	DGD Sweep Gate Crank Weldment, Painted
4	GK6841	Rack and Pinion Spacer Tube
5	GK6845	Rack and Pinion Crank Shaft Hex
6	GC09859	Gear, Spur 10 DP 14.5 PA 1 in. F x 22T Martin #S1022; 1 in. Bore with .313 Pin H
7	S-4377	Pin, Spring 5/16 x 2 in. Plain Steel Slotted Rolled
8	GK4211	Washer, Flat 1 x 1.1/2 in. 10 Gauge ZN
9	GK1070	Bushing Bronze 1.377 x 1.013 ID x 1 in. L GC09359 Machined To Specified ID
10	S-2741	Bolt, HHCS 5/16-18 x 1-1/2 in. ZN Grade 5
11	S-845	Washer, Flat 5/16 in. USS ZN
12	S-3611	Nut, Flange 5/16-18 in. YDP Grade 2
13	S-10547	Pin, Safety Snap 5/16 x 1-3/8 in. ZN C1008-C1010 Carbon Steel
14	S-9067	Bolt, Flange 3/8-16 x 3/4 in. ZN Grade 5
15	S-248	Washer, Flat 3/8 in. 7/16 in. ID 1 in. OD YDP
16	GK80568	Rack and Pinion Rack Bar Assembly 10 in. - Farm DGD

Figure 7-10 Double rack and pinion parts - 8 in. and 12 in.

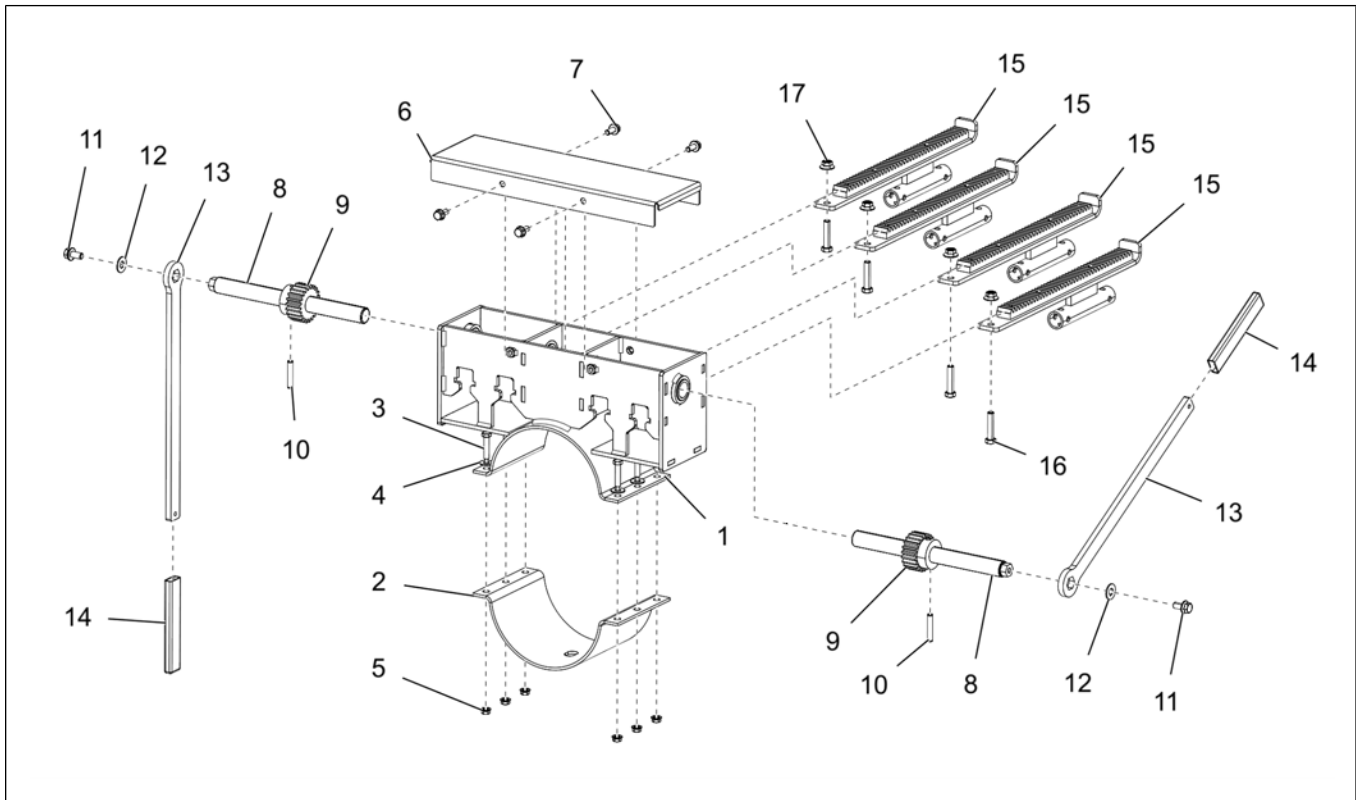


Table 7-11 Double rack and pinion (42 ft - 72 ft) parts list - 8 in. and 12 in.

Ref #	Part #	Description
1	GK81010	CGD Sweep: 8 in. Double Rack and Pinion Housing Assembly
	GK81024	CGD Sweep: 12 in. Double Rack and Pinion Housing Assembly
2	GK1326-BS	Band: Half 8 in. x 6 in. 7 Gauge - Bin Silver
	GC11749-BS	Band: Half 12 in. x 6 in. 7 Gauge - Bin Silver
3	S-2741	Bolt, HHCS 5/16-18 x 1-1/2 in. ZN Grade 5
4	S-845	Washer, Flat 5/16 in. USS ZN
5	S-3611	Nut, Flange 5/16-18 in. YDP Grade 2
6	GC20894	CGD Sweep: Double Rack and Pinion Cover
7	S-6606	Bolt, Flange 5/16-18 x 3/4 in. ZN Clear Grade 5
8	GK81012	CGD Sweep: Rack and Pinion Shaft
9	GC09859	Gear, Spur 10 DP 14.5 PA 1 in. F x 22T Martin
10	S-8397	Pin, Spring 5/16 x 1-3/4 in. Plain Steel SL
11	S-9067	Bolt, Flange 3/8-16 x 3/4 in. ZN Grade 5
12	S-248	Washer, Flat 3/8 in. 7/16 in. ID 1 in. OD YDP
13	GK7258	Wrench, 3/4 in. Hex, 16-7/8 in. Plated
14	GK7259	Cap, 0.368 x 0.970 x 6 - 701-UV-89-Black
15	GK80968	CGD Sweep: Rack and Pinion Rack Bar Assembly
16	S-8706	Bolt, HHTB 3/8-16 x 1-3/4 in. ZN Grade 5 Full
17	S-968	Nut, Flange 3/8-16 in. ZN Grade 5 Wide Flange

# Bin Flange

Figure 7-11 Bin flange parts

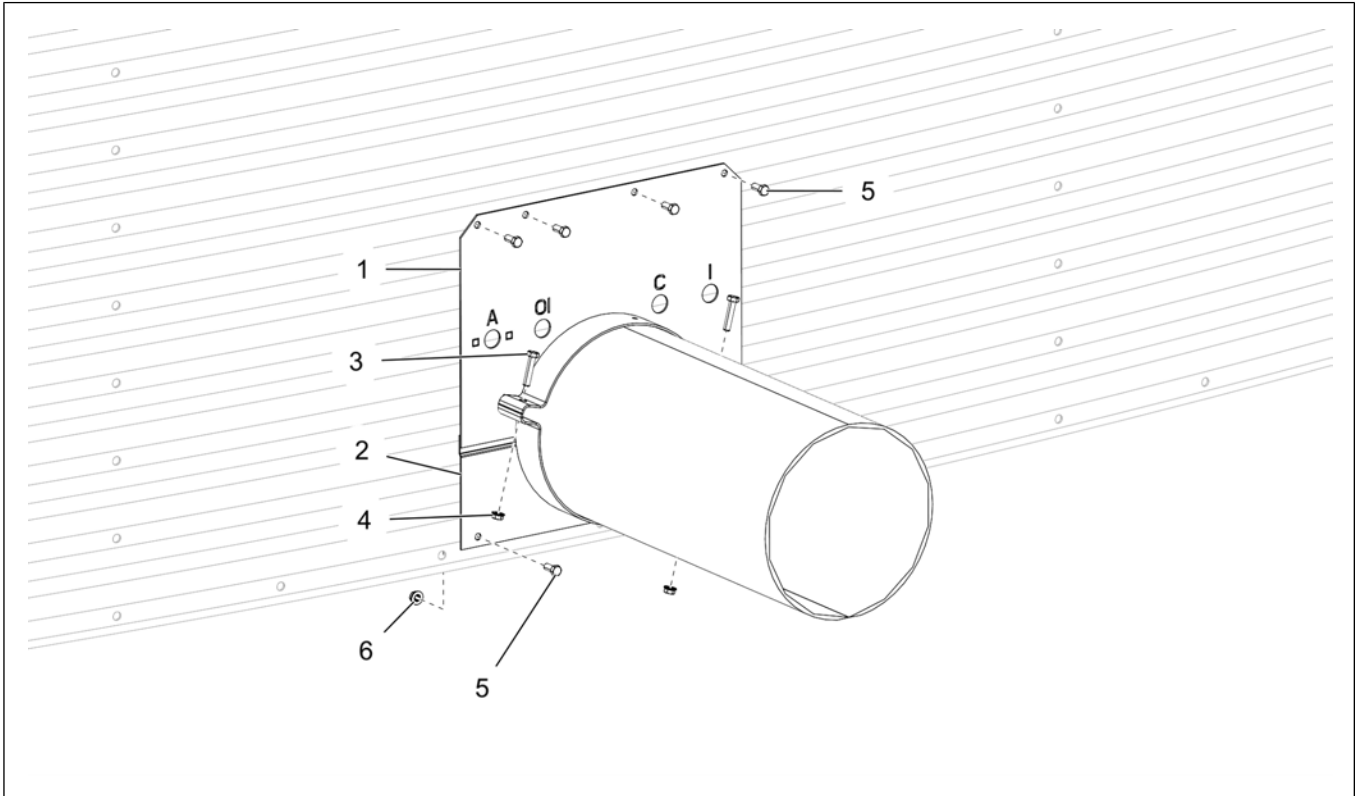


Table 7-12 Bin flange parts list

Ref #	Part #	Description
1	8101746	Chain Loop DGD: Control Rod Top Flange Assembly
	8101796	Chain Loop DGD: Back Side Control Rod Top Flange Assembly
2	8101747	Chain Loop DGD: Control Rod Bottom Flange Assembly
3	S-2741	Bolt, HHCS 5/16-18 x 1-1/2 in. ZN Grade 5
4	S-3611	Nut, Flange 5/16-18 in. YDP Grade 2
5		Standard Bin Bolt
6		Flange Nut

## Sweep Wheel

Figure 7-12 Sweep wheel parts

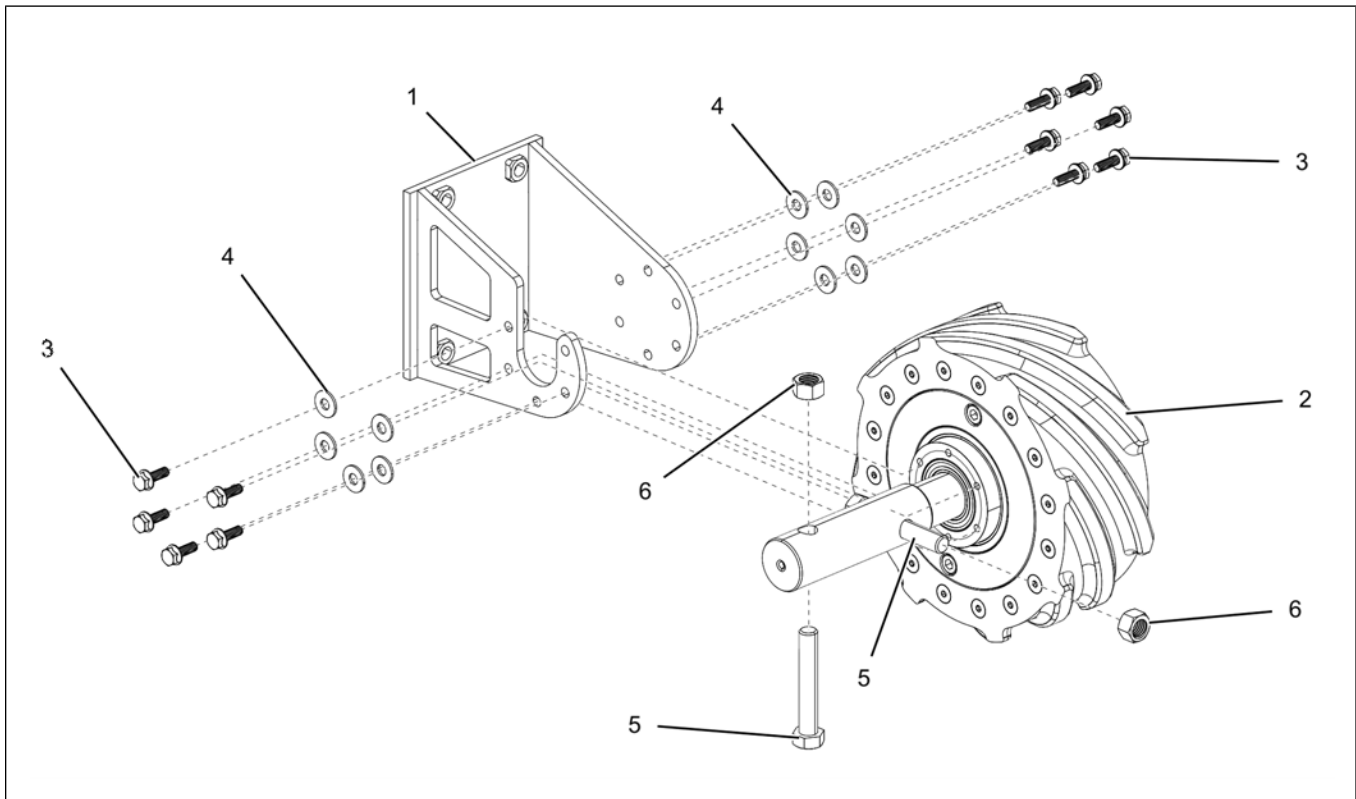


Table 7-13 Sweep wheel parts list

Ref #	Part #	Description
1	GK80714-Y	Wheel Housing Weldment – 10 in. HD
2	GK80627	Sweep Wheel 10.875 in. x 8.5:1 Ratio
3	S-8680	1/4 in. Flange Bolt
4	S-1430	1/4 in Flat Washer
5	S-7893	5/8 x 4 in. HHCS Bolt
6	S-8606	5/8 in. Stover Nut

# Backshield with Two Augers (30 ft Bins)

Figure 7-13 Backshield with two augers parts (30 ft)

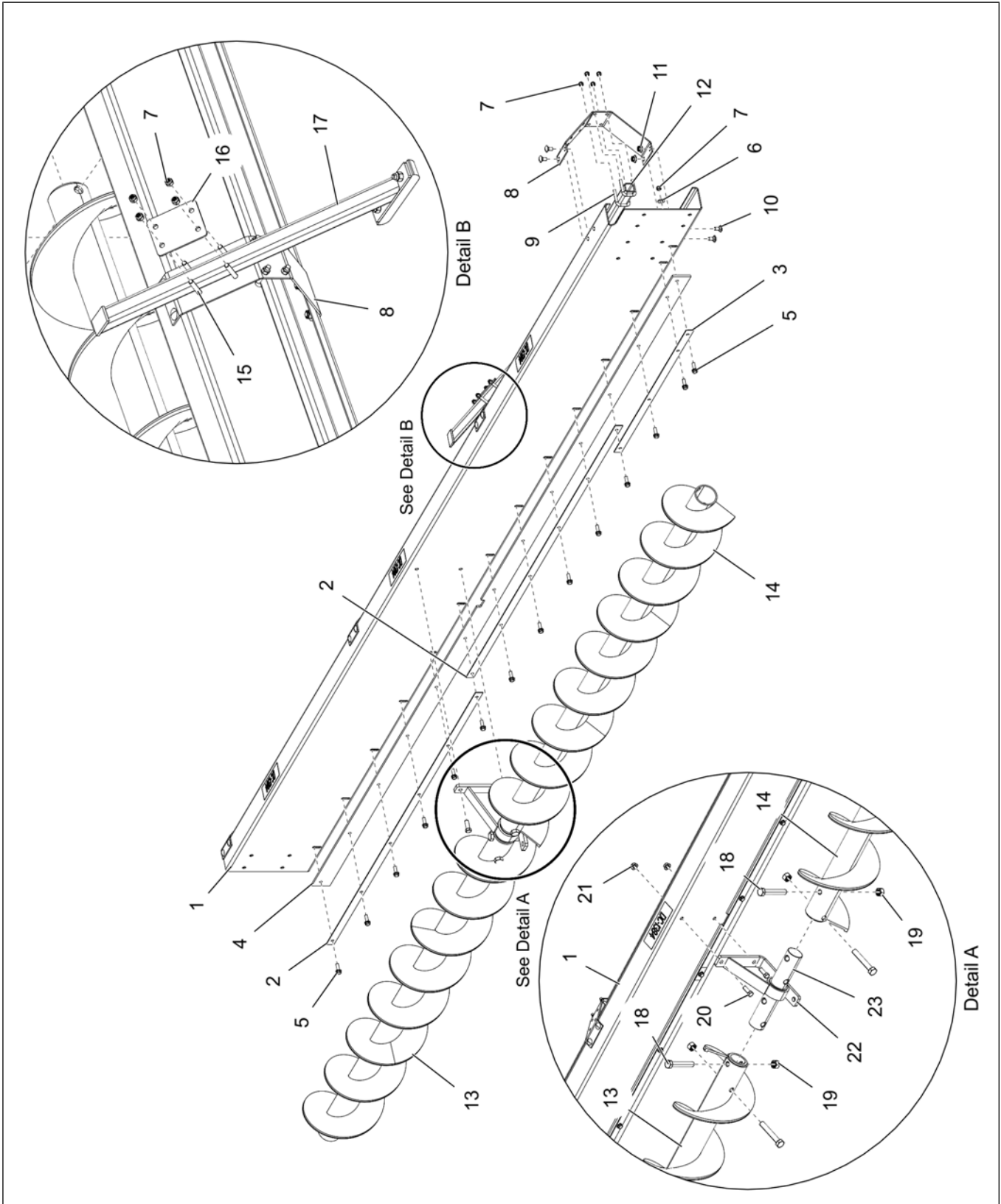


Table 7-14 Backshield with two augers parts list (30 ft)

Ref #	Part #	Description
1	GK80693	DGD Sweep Backshield - 10 in. x 30 ft. Bin HD
2	GK80534	DGD Sweep Wiper Retainer - Extension
3	GK80489	DGD Sweep Wiper Retainer
4	GK80500	DGD Sweep Backshield Wiper
5	S-7470	Bolt, Flange 5/16-18 x 1 in. ZN Grade 5
6	S-845	Washer, Flat 5/16 in. USS ZN
7	S-7382	Nut, Nylock 5/16-18 in. ZN Grade 5
8	GK80715	DGD Torque Tube Bracket
9	S-10521	Bolt, U-Bolt 5/16-18 x 1-1/4 in. IW x 2 in. IL x 3/4 in. TL ZN
10	S-7391	Bolt, Carriage 3/8-16 x 3/4 in. ZN Grade 5
11	S-968	Nut, Flange 3/8-16 in. ZN Grade 5 Wide Flange
12	GK81030	Torque Tube - 10 in.
	GK80478	Torque Tube - 8 in. and 12 in.
13	GK80727	Flight 9 in. x 6 ft. - 1.5 in. 1/4 in. Weldment
14	GK80728	Flight 9 in. x 6 ft. - 9.25 in. 1/4 in. Weldment
15	S-7877	Bolt, HHCS 5/16-18 x 2 in. ZN Grade 5
16	GK80610	DGD Backshield Support - Mount Plate
17	GK80609	DGD Sweep Backshield Support Bracket Assembly
18	S-7893	Bolt, HHCS 5/8-11 x 4 in. YDP Grade 8
19	S-8606	Nut, Stover 5/8-11 in. ZN Grade C
20	S-3886	Bolt, HHCS 7/16-14 x 1-1/4 in. ZN Grade 5
21	S-9073	Nut, Flange 7/16-14 in. ZN
22	GK80711	DGD Hanger Bracket Assembly - 10 in. HD
23	GK2222	Connecting Shaft 2.00 in. OD x 11.5 in.

# Backshield with Three Augers (33 ft - 42 ft Bins)

Figure 7-14 Backshield with three augers parts (33 ft - 42 ft)

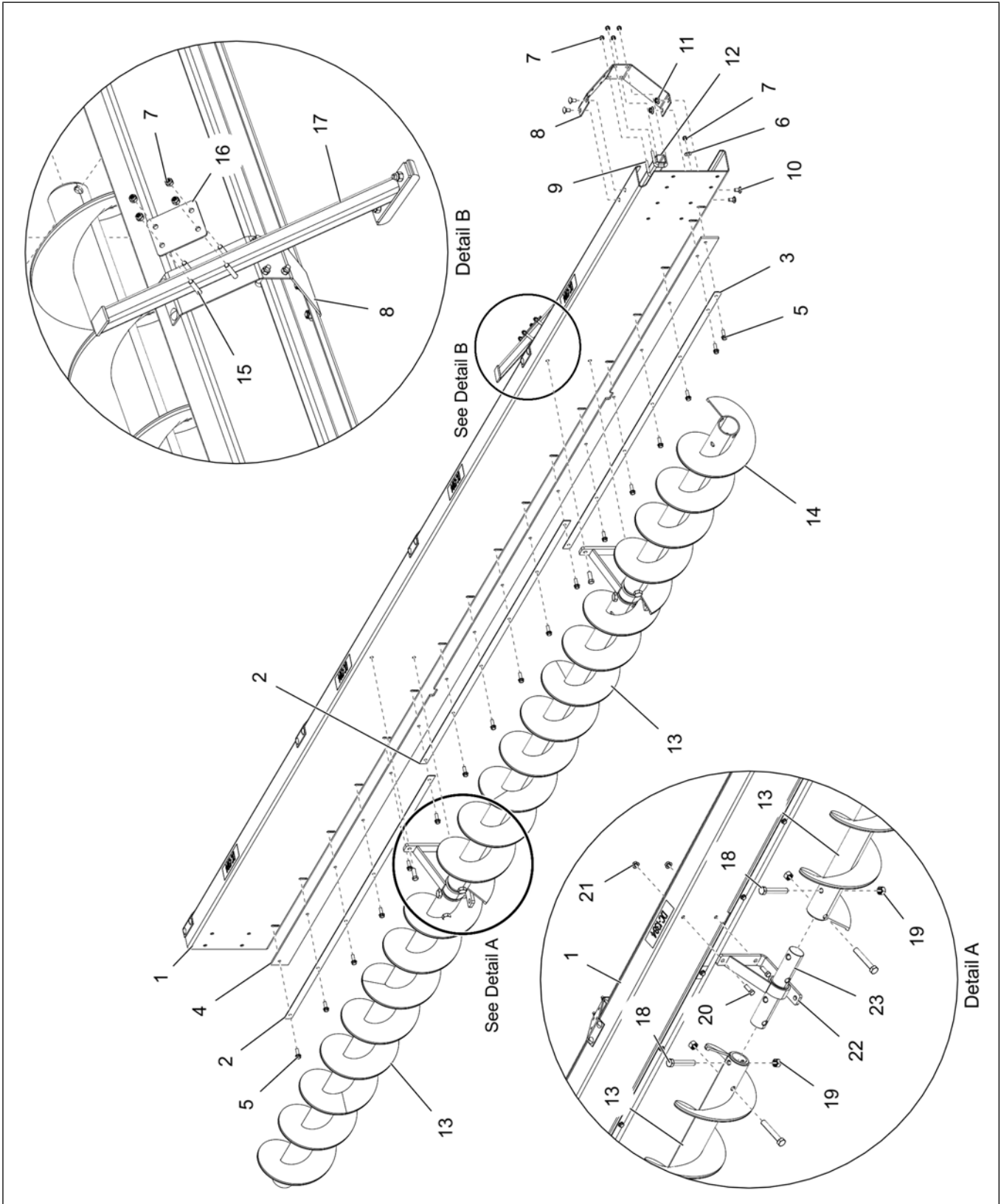




Table 7-15 Backshield with three augers parts list (33 ft - 42 ft)

Ref #	Part #	Description
1	GK80694	DGD Sweep Backshield - 10 in. x 33 ft. Bin HD
	GK80695	DGD Sweep Backshield - 10 in. x 36 ft. Bin HD
		DGD Sweep Backshield - 10 in. x 39 ft. Bin HD
	GK80696	DGD Sweep Backshield - 10 in. x 42 ft. Bin HD
2	GK80534	DGD Sweep Wiper Retainer - Extension
3	GK80490	DGD Sweep Wiper Retainer - 33 ft. Bin
	GK80491	DGD Sweep Wiper Retainer - 36 ft. Bin
		DGD Sweep Wiper Retainer - 39 ft. Bin
	GK80492	DGD Sweep Wiper Retainer - 42 ft. Bin
4	GK80501	DGD Sweep Backshield Wiper - 33 ft. Bin
	GK80502	DGD Sweep Backshield Wiper - 36 ft. Bin
		DGD Sweep Backshield Wiper - 39 ft. Bin
	GK80503	DGD Sweep Backshield Wiper - 42 ft. Bin
5	S-7470	Bolt, Flange 5/16-18 x 1 in. ZN Grade 5
6	S-845	Washer, Flat 5/16 in. USS ZN
7	S-7382	Nut, Nylock 5/16-18 in. ZN Grade 5
8	GK80715	DGD Torque Tube Bracket
9	S-10521	Bolt, U-Bolt 5/16-18 x 1-1/4 in. IW x 2 in. IL x 3/4 in. TL ZN
10	S-7391	Bolt, Carriage 3/8-16 x 3/4 in. ZN Grade 5
11	S-968	Nut, Flange 3/8-16 in. ZN Grade 5 Wide Flange
12	GK81031	Torque Tube - 33 ft. bin - 10 in.
	GK81032	Torque Tube - 36 ft. bin - 10 in.
		Torque Tube - 39 ft. bin - 10 in.
	GK81033	Torque Tube - 42 ft. bin - 10 in.
	GK80479	Torque Tube - 33 ft. bin - 8 in. and 12 in.
	GK80480	Torque Tube - 36 ft. bin - 8 in. and 12 in.
	GK80481	Torque Tube - 42 ft. bin - 8 in. and 12 in.
13	GK80727	Flight 9 in. x 6 ft. - 1.5 in. 1/4 in. Weldment
14	GK80729	Flight 9 in. x 1 ft. - 11.5 in. 1/4 in. Weldment - 33 ft. Bin
	GK80730	Flight 9 in. x 3 ft. - 5 in. 1/4 in. Weldment - 36 ft. Bin
		Flight - 39 ft. Bin
	GK80731	Flight 9 in. x 6 ft. - 4.5 in. 3/16 in. Weldment - 42 ft. Bin
15	S-7877	Bolt, HHCS 5/16-18 x 2 in. ZN Grade 5
16	GK80610	DGD Backshield Support - Mount Plate
17	GK80609	DGD Sweep Backshield Support Bracket Assembly
18	S-7893	Bolt, HHCS 5/8-11 x 4 in. YDP Grade 8
19	S-8606	Nut, Stover 5/8-11 in. ZN Grade C
20	S-3886	Bolt, HHCS 7/16-14 x 1-1/4 in. ZN Grade 5
21	S-9073	Nut, Flange 7/16-14 in. ZN
22	GK80711	DGD Hanger Bracket Assembly - 10 in. HD
23	GK2222	Connecting Shaft 2.00 in. OD x 11.5 in.

# Backshield with Four Augers (48 ft Bins)

Figure 7-15 Backshield with four augers parts (48 ft)

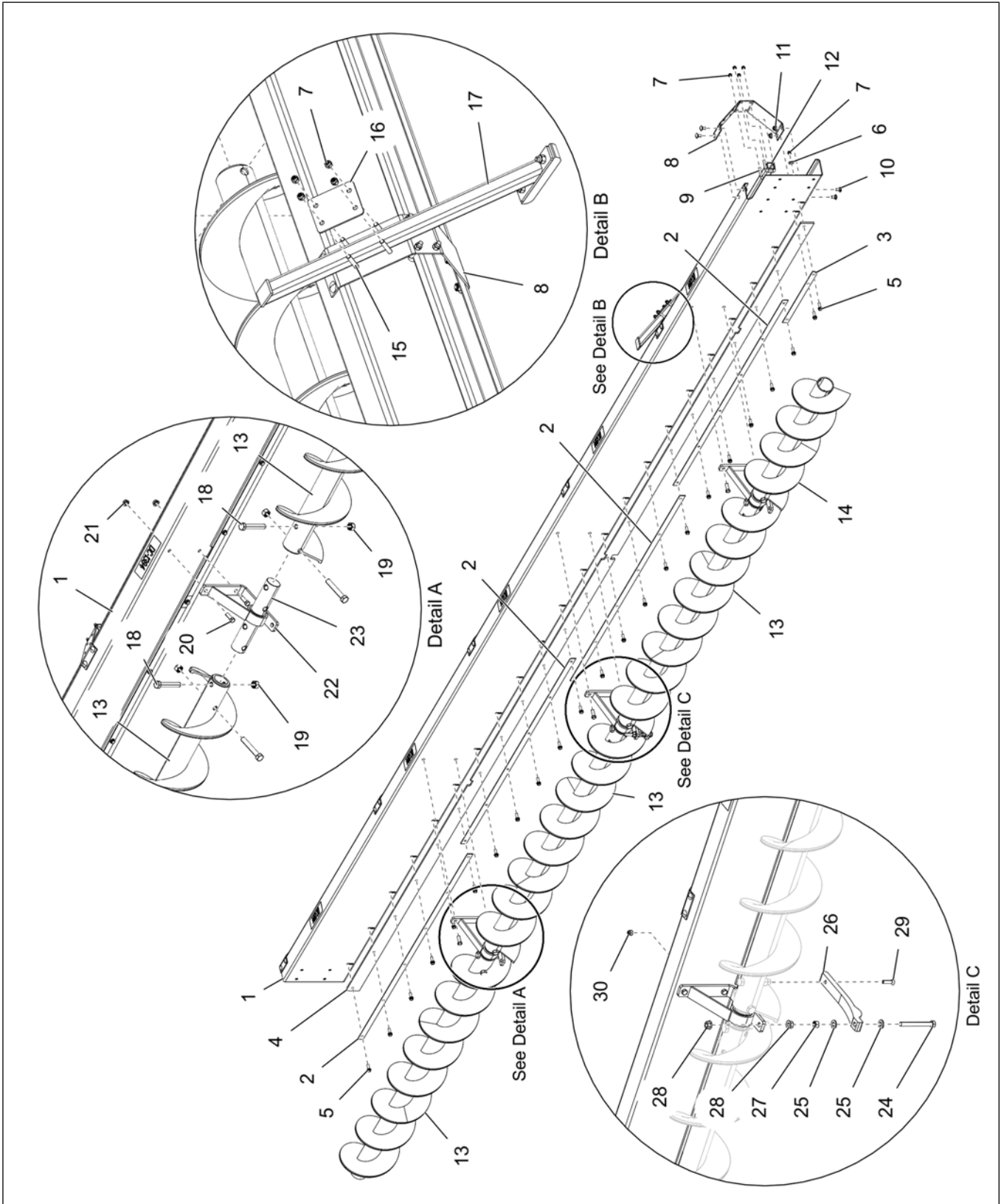


Table 7-16 Backshield with four augers parts list (48 ft)

Ref #	Part #	Description
1	GK80697	DGD Sweep Backshield - 10 in. x 48 ft. Bin HD
2	GK80534	DGD Sweep Wiper Retainer - Extension
3	GK80493	DGD Sweep Wiper Retainer
4	GK80504	DGD Sweep Backshield Wiper
5	S-7470	Bolt, Flange 5/16-18 x 1 in. ZN Grade 5
6	S-845	Washer, Flat 5/16 in. USS ZN
7	S-7382	Nut, Nylock 5/16-18 in. ZN Grade 5
8	GK80715	DGD Torque Tube Bracket
9	S-10521	Bolt, U-Bolt 5/16-18 x 1-1/4 in. IW x 2 in. IL x 3/4 in. TL ZN
10	S-7391	Bolt, Carriage 3/8-16 x 3/4 in. ZN Grade 5
11	S-968	Nut, Flange 3/8-16 in. ZN Grade 5 Wide Flange
12	GK81034	Torque Tube - 10 in.
	GK80482	Torque Tube - 12 in.
13	GK80727	Flight 9 in. x 6 ft. - 1.5 in. 1/4 in. Weldment
14	GK80732	Flight 9 in. x 1 ft. - 11.5 in. 1/4 in. Weldment
15	S-7877	Bolt, HHCS 5/16-18 x 2 in. ZN Grade 5
16	GK80610	DGD Backshield Support - Mount Plate
17	GK80609	DGD Sweep Backshield Support Bracket Assembly
18	S-7893	Bolt, HHCS 5/8-11 x 4 in. YDP Grade 8
19	S-8606	Nut, Stover 5/8-11 in. ZN Grade C
20	S-3886	Bolt, HHCS 7/16-14 x 1-1/4 in. ZN Grade 5
21	S-9073	Nut, Flange 7/16-14 in. ZN
22	GK80711	DGD Hanger Bracket Assembly - 10 in. HD
23	GK2222	Connecting Shaft 2.00 in. OD x 11.5 in.
24	2FH1038	Bolt, HHTB 1/2-13 x 4-1/2 in. ZN Grade 2
25	S-2120	Washer, Flat 1/2 in. SAE ZN
26	GK80725	DGD Sweep Support Skid - 10 in. HD
27	S-8315	Nut, Lock 1/2-13 in. ZN Grade C
28	S-8506	Nut, Flange 1/2-13 in. ZN
29	S-8255	Bolt, FHSCS 3/8-16 x 1-1/2 ZN 82 Degree
30	S-7383	Nut, Nylock 3/8-16 in. ZN Clear Grade 5

# Backshield with Four Augers (54 ft Bins)

Figure 7-16 Backshield with four augers parts (54 ft)

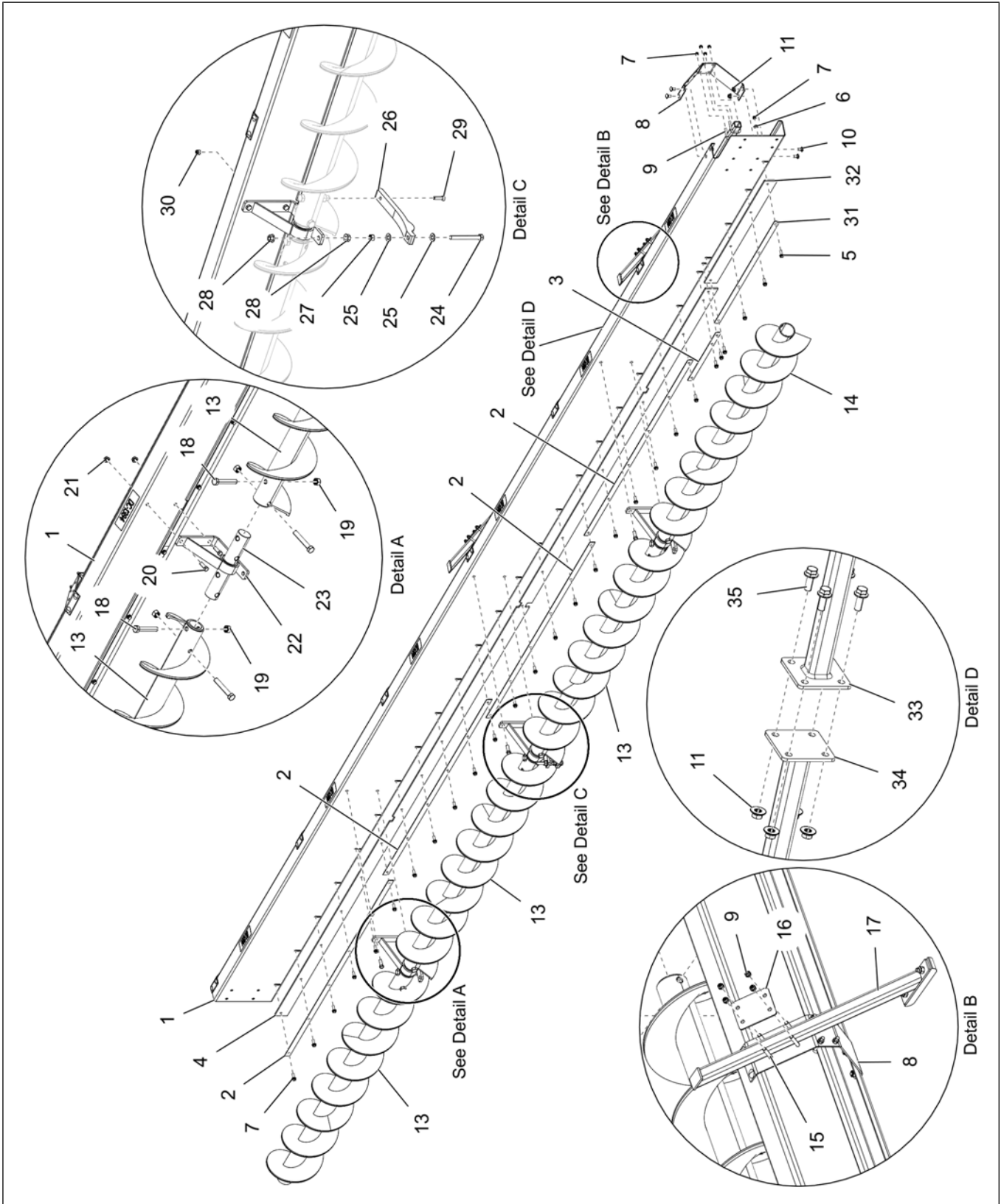


Table 7-17 Backshield with four augers parts list (54 ft)

Ref #	Part #	Description
1	GK80698	DGD Sweep Backshield - 10 in. x 54 ft. Bin HD
2	GK80534	DGD Sweep Wiper Retainer - Extension
3	GK80493	DGD Sweep Wiper Retainer
4	GK80504	DGD Sweep Backshield Wiper
5	S-7470	Bolt, Flange 5/16-18 x 1 in. ZN Grade 5
6	S-845	Washer, Flat 5/16 in. USS ZN
7	S-7382	Nut, Nylock 5/16-18 in. ZN Grade 5
8	GK80715	DGD Torque Tube Bracket
9	S-10521	Bolt, U-Bolt 5/16-18 x 1-1/4 in. IW x 2 in. IL x 3/4 in. TL ZN
10	S-7391	Bolt, Carriage 3/8-16 x 3/4 in. ZN Grade 5
11	S-968	Nut, Flange 3/8-16 in. ZN Grade 5 Wide Flange
13	GK80727	Flight 9 in. x 6 ft. - 1.5 in. 1/4 in. Weldment
14	GK80798	Flight 9 in. x 6 ft. - 0.75 in. 1/4 in. Weldment
15	S-7877	Bolt, HHCS 5/16-18 x 2 in. ZN Grade 5
16	GK80610	DGD Backshield Support - Mount Plate
17	GK80609	DGD Sweep Backshield Support Bracket Assembly
18	S-7893	Bolt, HHCS 5/8-11 x 4 in. YDP Grade 8
19	S-8606	Nut, Stover 5/8-11 in. ZN Grade C
20	S-3886	Bolt, HHCS 7/16-14 x 1-1/4 in. ZN Grade 5
21	S-9073	Nut, Flange 7/16-14 in. ZN
22	GK80711	DGD Hanger Bracket Assembly - 10 in. HD
23	GK2222	Connecting Shaft 2.00 in. OD x 11.5 in.
24	2FH1038	Bolt, HHTB 1/2-13 x 4-1/2 in. ZN Grade 2
25	S-2120	Washer, Flat 1/2 in. SAE ZN
26	GK80725	DGD Sweep Support Skid - 10 in. HD
27	S-8315	Nut, Lock 1/2-13 in. ZN GRC
28	S-8506	Nut, Flange 1/2-13 in. ZN
29	S-8255	Bolt, FHSCS 3/8-16 x 1-1/2 ZN 82 Degree
30	S-7383	Nut, Nylock 3/8-16 in. ZN Clear Grade 5
31	GK80497	DGD Sweep Backshield Wiper Retainer - 10 in.
	GK80797	DGD Sweep Backshield Wiper Retainer - 8 in. and 12 in.
32	GK80772	DGD Sweep Backshield Wiper
33	GK81036	DGD Sweep Torque Tube Weldment - 10 in.
	GK80769	DGD Sweep Torque Tube Weldment - 8 in. and 12 in.
34	GK80768	DGD Sweep Torque Tube Weldment
35	S-9065	Bolt, Flange 3/8-16 x 1 in. ZN Grade 5



# Backshield with Five Augers (60 ft Bins)

Figure 7-17 Backshield with five augers parts (60 ft)

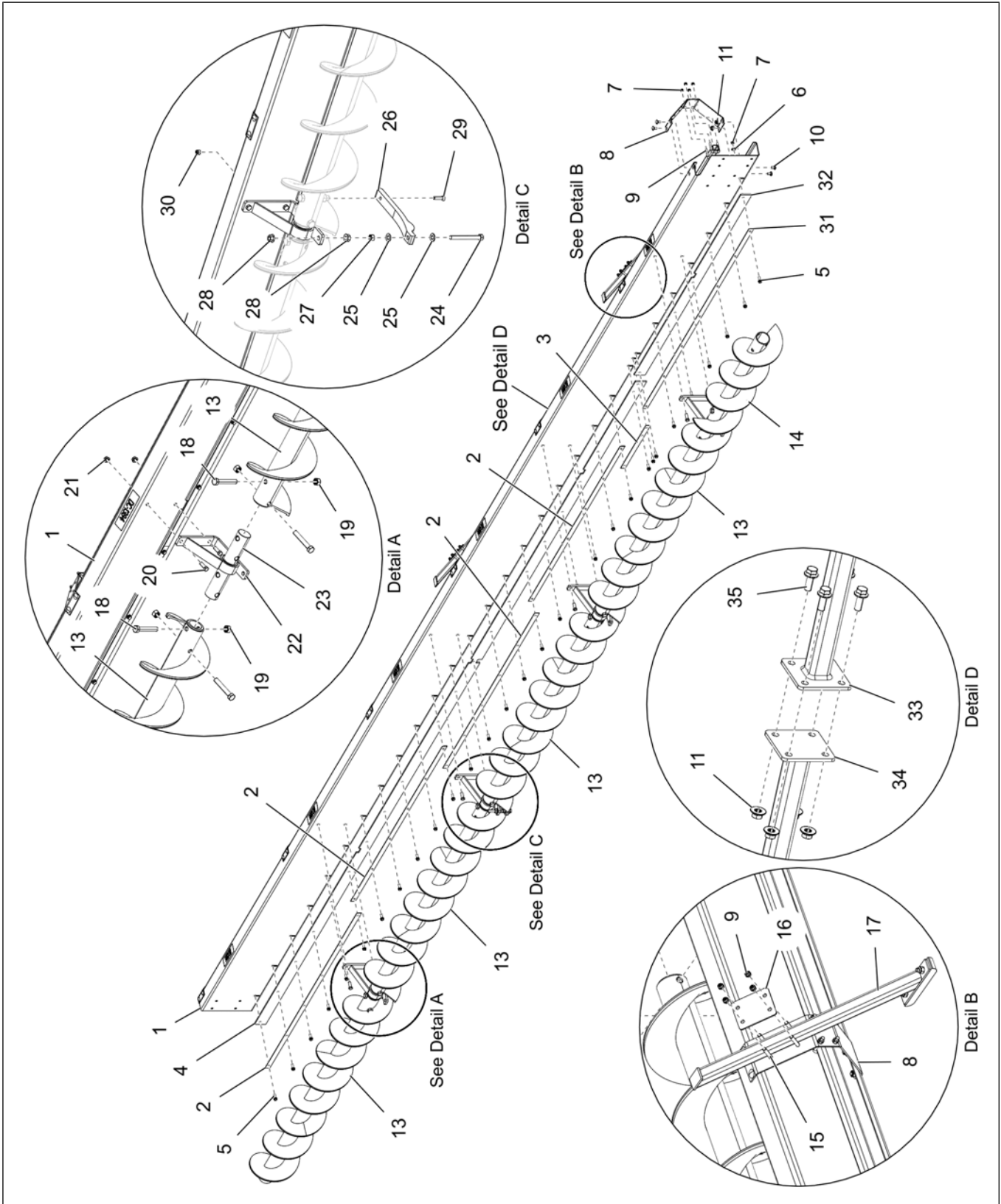


Table 7-18 Backshield with five augers parts list (60 ft)

Ref #	Part #	Description
1	GK80699	DGD Sweep Backshield - 10 in. x 60 ft. Bin HD
2	GK80534	DGD Sweep Wiper Retainer - Extension
3	GK80493	DGD Sweep Wiper Retainer
4	GK80504	DGD Sweep Backshield Wiper
5	S-7470	Bolt, Flange 5/16-18 x 1 in. ZN Grade 5
6	S-845	Washer, Flat 5/16 in. USS ZN
7	S-7382	Nut, Nylock 5/16-18 in. ZN Grade 5
8	GK80715	DGD Torque Tube Bracket
9	S-10521	Bolt, U-Bolt 5/16-18 x 1-1/4 in. IW x 2 in. IL x 3/4 in. TL ZN
10	S-7391	Bolt, Carriage 3/8-16 x 3/4 in. ZN Grade 5
11	S-968	Nut, Flange 3/8-16 in. ZN Grade 5 Wide Flange
13	GK80727	Flight 9 in. x 6 ft. - 1.5 in. 1/4 in. Weldment
14	GK80799	Flight 9 in. x 2 ft. - 9 in. 1/4 in. Weldment
15	S-7877	Bolt, HHCS 5/16-18 x 2 in. ZN Grade 5
16	GK80610	DGD Backshield Support - Mount Plate
17	GK80609	DGD Sweep Backshield Support Bracket Assembly
18	S-7893	Bolt, HHCS 5/8-11 x 4 in. YDP Grade 8
19	S-8606	Nut, Stover 5/8-11 in. ZN Grade C
20	S-3886	Bolt, HHCS 7/16-14 x 1-1/4 in. ZN Grade 5
21	S-9073	Nut, Flange 7/16-14 in. ZN
22	GK80711	DGD Hanger Bracket Assembly - 10 in. HD
23	GK2222	Connecting Shaft 2.00 in. OD x 11.5 in.
24	2FH1038	Bolt, HHTB 1/2-13 x 4-1/2 in. ZN Grade 2
25	S-2120	Washer, Flat 1/2 in. SAE ZN
26	GK80725	DGD Sweep Support Skid - 10 in. HD
27	S-8315	Nut, Lock 1/2-13 in. ZN Grade C
28	S-8506	Nut, Flange 1/2-13 in. ZN
29	S-8255	Bolt, FHSCS 3/8-16 x 1-1/2 ZN 82 Degree
30	S-7383	Nut, Nylock 3/8-16 in. ZN Clear Grade 5
31	GK80782	DGD Sweep Backshield Wiper Retainer
32	GK80773	DGD Sweep Backshield Wiper
33	GK80778	DGD Sweep Torque Tube Weldment
34	GK81038	DGD Sweep Torque Tube Weldment - 10 in.
	GK80779	DGD Sweep Torque Tube Weldment - 8 in. and 12 in.
35	S-9065	Bolt, Flange 3/8-16 x 1 in. ZN Grade 5



# Backshield with Five Augers (66 Ft Bins)

Figure 7-18 Backshield with five augers parts (66 ft)

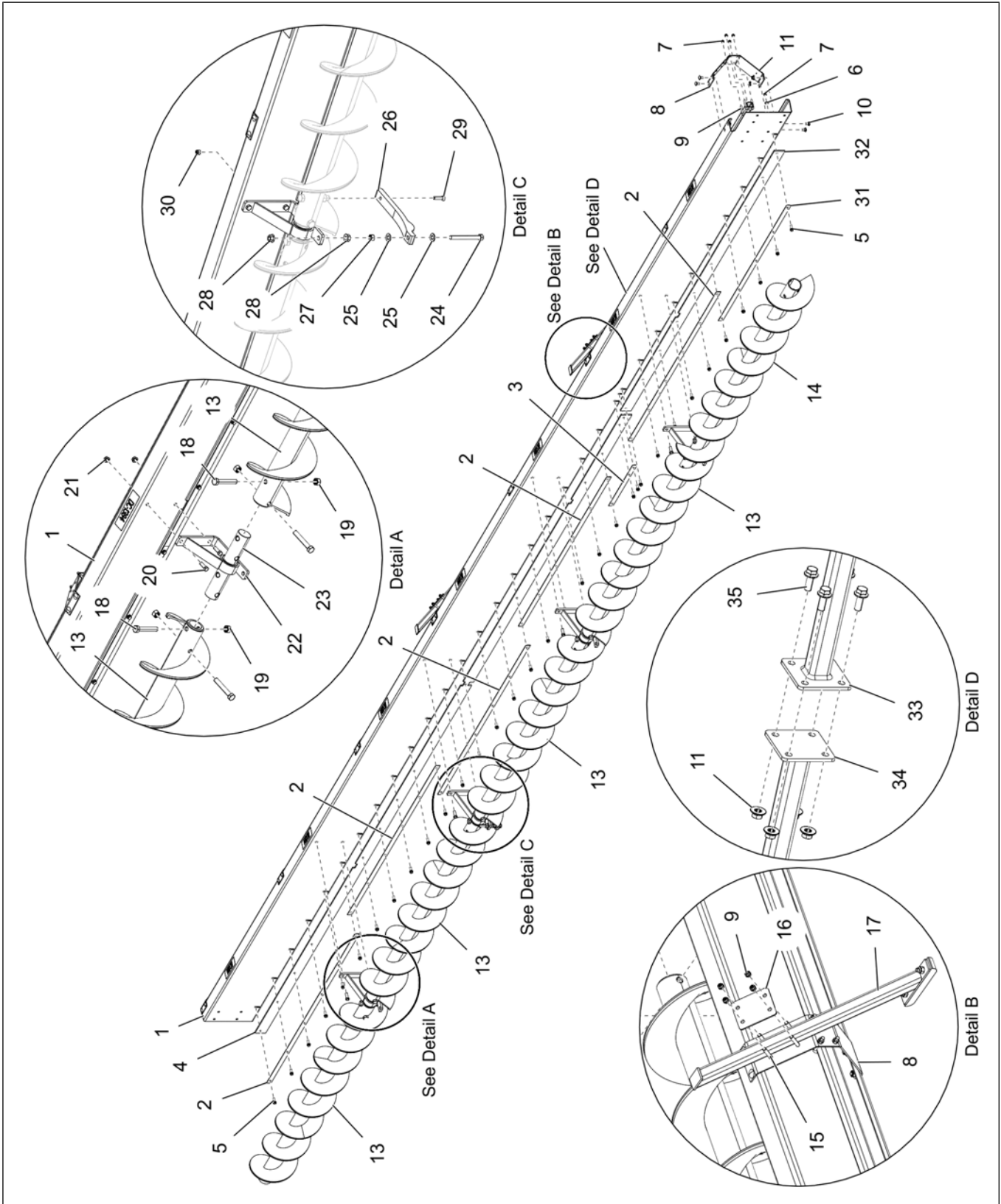


Table 7-19 Backshield with five augers parts list (66 ft)

Ref #	Part #	Description
1	GK80700	DGD Sweep Backshield - 10 in. x 66 ft. Bin HD
2	GK80534	DGD Sweep Wiper Retainer - Extension
3	GK80493	DGD Sweep Wiper Retainer
4	GK80504	DGD Sweep Backshield Wiper
5	S-7470	Bolt, Flange 5/16-18 x 1 in. ZN Grade 5
6	S-845	Washer, Flat 5/16 in. USS ZN
7	S-7382	Nut, Nylock 5/16-18 in. ZN Grade 5
8	GK80715	DGD Torque Tube Bracket
9	S-10521	Bolt, U-Bolt 5/16-18 x 1-1/4 in. IW x 2 in. IL x 3/4 in. TL ZN
10	S-7391	Bolt, Carriage 3/8-16 x 3/4 in. ZN Grade 5
11	S-968	Nut, Flange 3/8-16 in. ZN Grade 5 Wide Flange
13	GK80727	Flight 9 in. x 6 ft. - 1.5 in. 1/4 in. Weldment
14	GK80800	Flight 9 in. x 5 ft. - 9 in. 1/4 in. Weldment
15	S-7877	Bolt, HHCS 5/16-18 x 2 in. ZN Grade 5
16	GK80610	DGD Backshield Support - Mount Plate
17	GK80609	DGD Sweep Backshield Support Bracket Assembly
18	S-7893	Bolt, HHCS 5/8-11 x 4 in. YDP Grade 8
19	S-8606	Nut, Stover 5/8-11 in. ZN Grade C
20	S-3886	Bolt, HHCS 7/16-14 x 1-1/4 in. ZN Grade 5
21	S-9073	Nut, Flange 7/16-14 in. ZN
22	GK80711	DGD Hanger Bracket Assembly - 10 in. HD
23	GK2222	Connecting Shaft 2.00 in. OD x 11.5 in.
24	2FH1038	Bolt, HHTB 1/2-13 x 4-1/2 in. ZN Grade 2
25	S-2120	Washer, Flat 1/2 in. SAE ZN
26	GK80725	DGD Sweep Support Skid - 10 in. HD
27	S-8315	Nut, Lock 1/2-13 in. ZN GRC
28	S-8506	Nut, Flange 1/2-13 in. ZN
29	S-8255	Bolt, FHSCS 3/8-16 x 1-1/2 ZN 82 Degree
30	S-7383	Nut, Nylock 3/8-16 in. ZN Clear Grade 5
31	GK80786	DGD Sweep Backshield Wiper Retainer
32	GK80774	DGD Sweep Backshield Wiper
33	GK80778	DGD Sweep Torque Tube Weldment
34	GK81040	DGD Sweep Torque Tube Weldment - 10 in.
	GK80788	DGD Sweep Torque Tube Weldment - 8 in. and 12 in.
35	S-9065	Bolt, Flange 3/8-16 x 1 in. ZN Grade 5

# Backshield with Six Augers (72 ft Bins)

Figure 7-19 Backshield with six augers parts (72 ft)

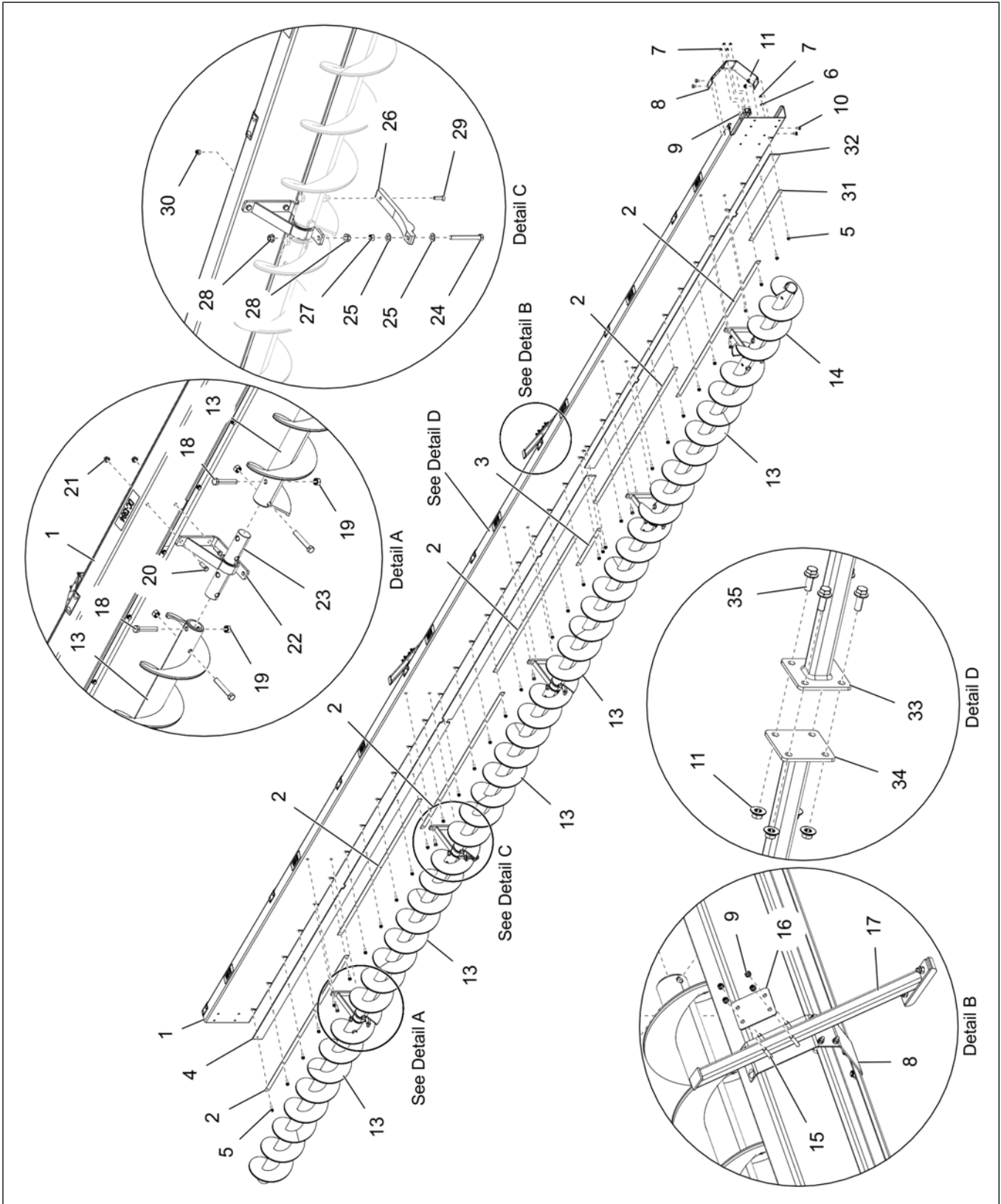


Table 7-20 Backshield with six augers parts list (72 ft)

Ref #	Part #	Description
1	GK80701	DGD Sweep Backshield - 10 in. x 72 ft. Bin HD
2	GK80534	DGD Sweep Wiper Retainer - Extension
3	GK80493	DGD Sweep Wiper Retainer
4	GK80504	DGD Sweep Backshield Wiper
5	S-7470	Bolt, Flange 5/16-18 x 1 in. ZN Grade 5
6	S-845	Washer, Flat 5/16 in. USS ZN
7	S-7382	Nut, Nylock 5/16-18 in. ZN Grade 5
8	GK80715	DGD Torque Tube Bracket
9	S-10521	Bolt, U-Bolt 5/16-18 x 1-1/4 in. IW x 2 in. IL x 3/4 in. TL ZN
10	S-7391	Bolt, Carriage 3/8-16 x 3/4 in. ZN Grade 5
11	S-968	Nut, Flange 3/8-16 in. ZN Grade 5 Wide Flange
13	GK80727	Flight 9 in. x 6 ft. - 1.5 in. 1/4 in. Weldment
14	GK80801	Flight 9 in. x 2 ft. - 4.25 in. 1/4 in. Weldment
15	S-7877	Bolt, HHCS 5/16-18 x 2 in. ZN Grade 5
16	GK80610	DGD Backshield Support - Mount Plate
17	GK80609	DGD Sweep Backshield Support Bracket Assembly
18	S-7893	Bolt, HHCS 5/8-11 x 4 in. YDP Grade 8
19	S-8606	Nut, Stover 5/8-11 in. ZN Grade C
20	S-3886	Bolt, HHCS 7/16-14 x 1-1/4 in. ZN Grade 5
21	S-9073	Nut, Flange 7/16-14 in. ZN
22	GK80711	DGD Hanger Bracket Assembly - 10 in. HD
23	GK2222	Connecting Shaft 2.00 in. OD x 11.5 in.
24	2FH1038	Bolt, HHTB 1/2-13 x 4-1/2 in. ZN Grade 2
25	S-2120	Washer, Flat 1/2 in. SAE ZN
26	GK80725	DGD Sweep Support Skid - 10 in. HD
27	S-8315	Nut, Lock 1/2-13 in. ZN GRC
28	S-8506	Nut, Flange 1/2-13 in. ZN
29	S-8255	Bolt, FHSCS 3/8-16 x 1-1/2 ZN 82 Degree
30	S-7383	Nut, Nylock 3/8-16 in. ZN Clear Grade 5
31	GK80680	DGD Sweep Wiper Retainer - Short
32	GK80775	DGD Sweep Backshield Wiper
33	GK80768	DGD Sweep Torque Tube Weldment
34	GK81042	DGD Sweep Torque Tube Weldment - 10 in.
	GK80794	DGD Sweep Torque Tube Weldment - 8 in. and 12 in.
35	S-9065	Bolt, Flange 3/8-16 x 1 in. ZN Grade 5

# Drive Head

Figure 7-20 Drive head parts

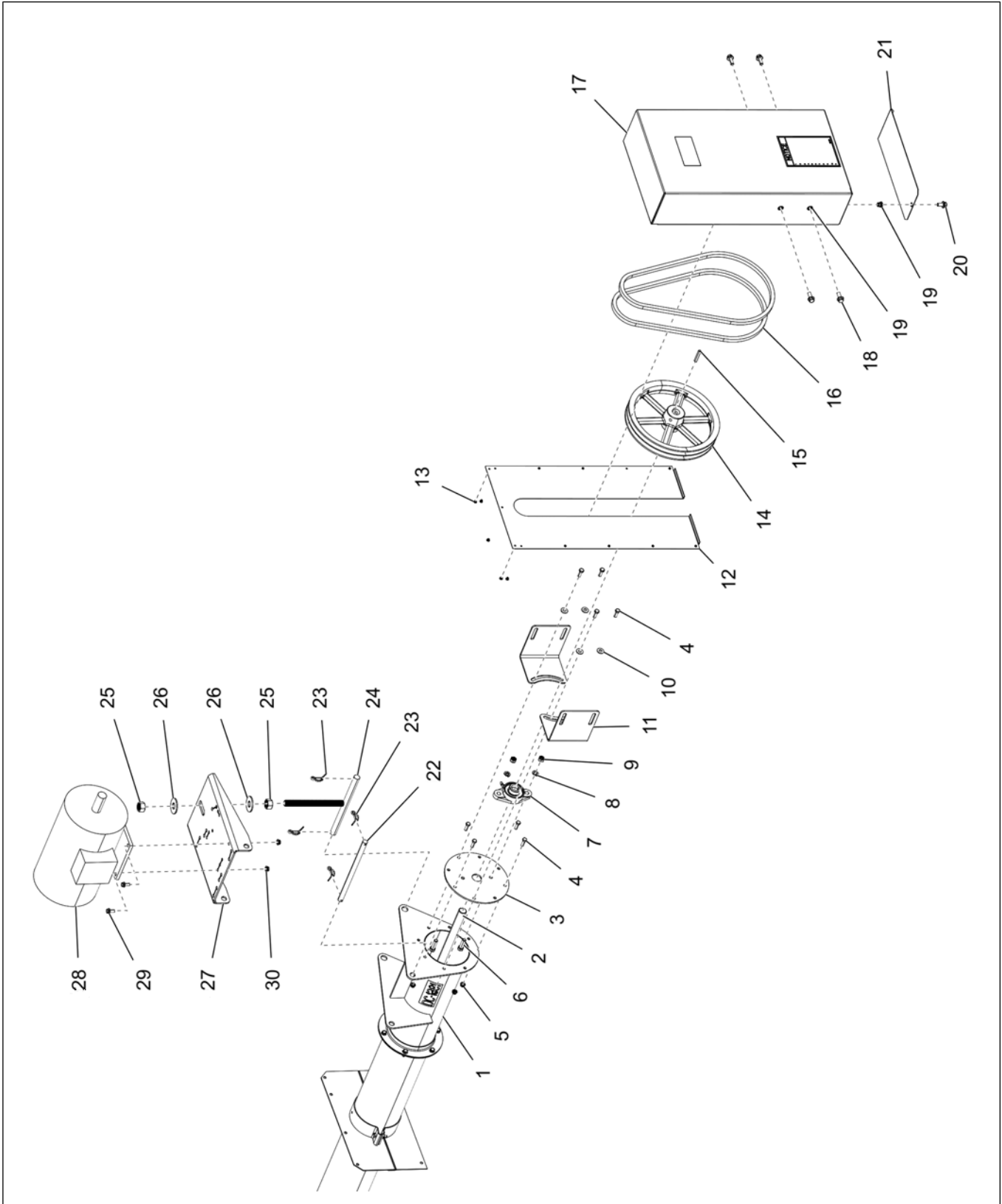


Table 7-21 Drive head parts list

Ref #	Part #	Description
1	GK6996X	Tube: 6 in. Horizontal Assembly No Discharge
2	8101799	OS Drive Shaft 36 ft. And Larger
3	GK7061-BS	Bearing Plate: 6 in. Horizontal - Bin Silver
4	S-1196	Bolt, HHCS 5/16-18 x 1 in. ZN Grade 5
5	S-3611	Nut, Flange 5/16-18 in. YDP Grade 2
6	S-7837	Bolt, HHCS 7/16-14 x 1-1/2 in. ZN Grade 5
7	GK1049	Bearing, Light Duty 1.00 in. Bore 2 Hole Flange W/ Locking Collar
8	S-7014	Washer, Split Lock 7/16 in. ZN MED
9	S-7332	Nut, Hex 7/16-14 in. YDP Grade 5
10	S-845	Washer, Flat 5/16 in. USS ZN
11	8101752	Chain Loop DGD: Belt Guard Brackets - 10 in.
12	GC20758	Chain Loop Sweep: Belt Guard Back 12 in.
13	S-7235	Rivet, PMG 3/16 in. Diameter x 0.440 Long ARSM 0.063 - 0.250 Grip Range
14	GK1321	Sheave, 2 Grade, B Belt, 1 in. B, 12 in. O.D. - Aluminium
15	S-4513	Key, 1/4 in. x 1/4 in. x 2 in. Stock For Shaft
16	GC06680	Belt, V B x 48
17	GC20757	Chain Loop Sweep: Belt Guard Front 12 in.
18	S-9065	Bolt, Flange 3/8-16 x 1 in. ZN Grade 5
19	50-0043	Insert, Threaded 3/8-16 in.
20	S-9067	Bolt, Flange 3/8-16 x 3/4 in. ZN Grade 5
21	GC20759	Chain Loop Sweep: Belt Guard Bottom 12 in.
22	GK7058	Motor Mount: Plate Pivot Rod 6 In.
23	S-6994	Pin, Cotter 3/16 x 2 in. ZN Grade 2
24	GK7060	Motor Mount: Adjustment Rod Weld 6 in.
25	S-234	Nut, Hex 3/4-10 in. ZN Grade 5, Zinc Plated
26	S-866	Washer, Flat 3/4 in. USS ZN
27	GK7052	Motor Plate: 6 in.
28		Motor
29		Bolt
30		Nut



## Backshield Connections

Figure 7-21 Backshield connections parts

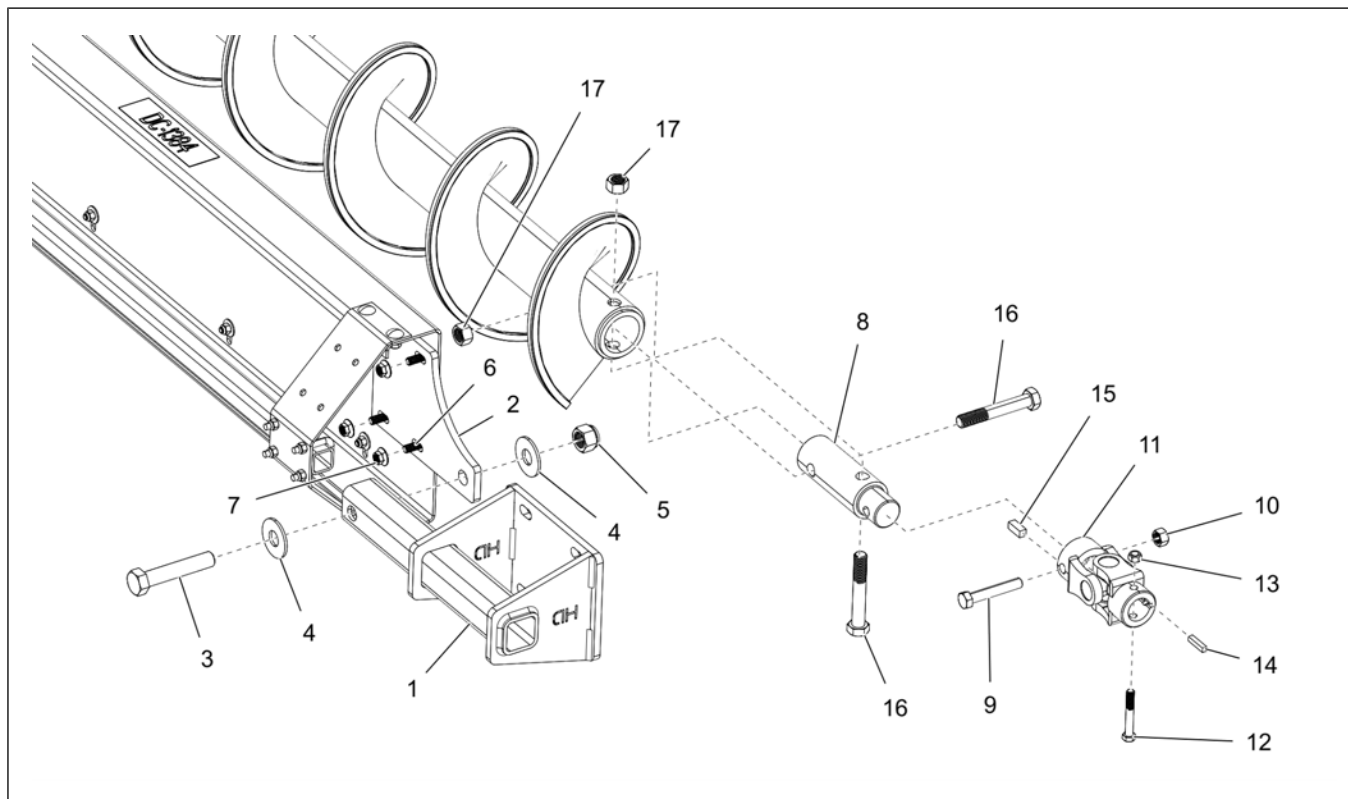


Table 7-22 Backshield connections parts list

Ref #	Part #	Description
1	GK80713-Y	Gearbox Mount Assembly - 10 in. HD
2	GK80608-Y	Backshield Pivot Bracket - 8 in.
3	S-7884	3/4 x 4 in. HHCS Bolt
4	S-866	3/4 in. Flat Washer
5	S-7217	3/4 in. Nylock Nut
6	S-9066	3/8 in. Flange Bolt
7	S-968	3/8 in. Flange Nut
8	GK80726	2 in. x 6.5 in. U-Joint Connecting Shaft
9	S-8252	1/2 x 3 in. HHCS Bolt
10	S-8315	1/2 in. Stover Nut
11	GK7614	U-Joint 1.25 in. B and 1.5 in. B x 5.50 in. Long 12E
12	S-10107	3/8 in. HHCS Bolt
13	S-8251	3/8 in. Stover Nut
14	S-8382	1/4 x 1/4 x 1-1/4 in. Square Key
15	GC03540	3/8 x 3/8 x 1 in. Key
16	S-7893	5/8 x 4 in. HHCS Bolt
17	S-8606	5/8 in. Stover Nut



## GSI Group, LLC Limited Warranty

The GSI Group, LLC (“GSI”) warrants products which it manufactures to be free of defects in materials and workmanship under normal usage and conditions for a period of 12 months after sale to the original end-user or if a foreign sale, 14 months from arrival at port of discharge, whichever is earlier. The end-user’s sole remedy (and GSI’s only obligation) is to repair or replace, at GSI’s option and expense, products that in GSI’s judgment, contain a material defect in materials or workmanship. Expenses incurred by or on behalf of the end-user without prior written authorization from the GSI Warranty Group shall be the sole responsibility of the end-user.

**Warranty Extensions:** The Limited Warranty period is extended for the following products:

	Product	Warranty Period
<b>AP Fans and Flooring</b>	Performer Series Direct Drive Fan Motor	3 Years
	All Fiberglass Housings	Lifetime
	All Fiberglass Propellers	Lifetime
<b>AP/Cumberland</b>	Flex-Flo/Pan Feeding System Motors	2 Years
<b>Cumberland Feeding/Watering Systems</b>	Feeder System Pan Assemblies	5 Years **
	Feed Tubes (1-3/4" and 2.00")	10 Years *
	Centerless Augers	10 Years *
	Watering Nipples	10 Years *
<b>Grain Systems</b>	Grain Bin Structural Design	5 Years
<b>Grain Systems Farm Fans Zimmerman</b>	Portable and Tower Dryers	2 Years
	Portable and Tower Dryer Frames and Internal Infrastructure †	5 Years

\* Warranty prorated from list price:  
 0 to 3 years - no cost to end-user  
 3 to 5 years - end-user pays 25%  
 5 to 7 years - end-user pays 50%  
 7 to 10 years - end-user pays 75%

\*\* Warranty prorated from list price:  
 0 to 3 years - no cost to end-user  
 3 to 5 years - end-user pays 50%

† Motors, burner components and moving parts not included.  
 Portable dryer screens included.  
 Tower dryer screens not included.

GSI further warrants that the portable and tower dryer frame and basket, excluding all auger and auger drive components, shall be free from defects in materials for a period of time beginning on the twelfth (12<sup>th</sup>) month from the date of purchase and continuing until the sixtieth (60<sup>th</sup>) month from the date of purchase (extended warranty period). During the extended warranty period, GSI will replace the frame or basket components that prove to be defective under normal conditions of use without charge, excluding the labor, transportation, and/or shipping costs incurred in the performance of this extended warranty.

### Conditions and Limitations:

THERE ARE NO WARRANTIES THAT EXTEND BEYOND THE LIMITED WARRANTY DESCRIPTION SET FORTH ABOVE. SPECIFICALLY, GSI MAKES NO FURTHER WARRANTY OF ANY KIND, EXPRESS OR IMPLIED, INCLUDING, WITHOUT LIMITATION, WARRANTIES OF MERCHANTABILITY OR FITNESS FOR A PARTICULAR PURPOSE OR USE IN CONNECTION WITH: (I) PRODUCT MANUFACTURED OR SOLD BY GSI OR (II) ANY ADVICE, INSTRUCTION, RECOMMENDATION OR SUGGESTION PROVIDED BY AN AGENT, REPRESENTATIVE OR EMPLOYEE OF GSI REGARDING OR RELATED TO THE CONFIGURATION, INSTALLATION, LAYOUT, SUITABILITY FOR A PARTICULAR PURPOSE, OR DESIGN OF SUCH PRODUCTS.

GSI shall not be liable for any direct, indirect, incidental or consequential damages, including, without limitation, loss of anticipated profits or benefits. The sole and exclusive remedy is set forth in the Limited Warranty, which shall not exceed the amount paid for the product purchased. This warranty is not transferable and applies only to the original end-user. GSI shall have no obligation or responsibility for any representations or warranties made by or on behalf of any dealer, agent or distributor.

GSI assumes no responsibility for claims resulting from construction defects or unauthorized modifications to products which it manufactured. Modifications to products not specifically delineated in the manual accompanying the equipment at initial sale will void the Limited Warranty.

This Limited Warranty shall not extend to products or parts which have been damaged by negligent use, misuse, alteration, accident or which have been improperly/inadequately maintained. This Limited Warranty extends solely to products manufactured by GSI.

Prior to installation, the end-user has the responsibility to comply with federal, state and local codes which apply to the location and installation of products manufactured or sold by GSI.

9101239\_1\_CR\_rev8.xml (revised January 2014)

**This equipment shall be installed in accordance with the current installation codes and applicable regulations which should be carefully followed in all cases. Authorities having jurisdiction should be consulted before installations are made.**



1004 E. Illinois St.  
Assumption, IL 62510-0020  
Phone: 1-217-226-4421  
Fax: 1-217-226-4420  
[www.gsiag.com](http://www.gsiag.com)



GSI is a worldwide brand of AGCO Corporation.