

12" and 16" Series II Sweep

Owner's Manual

PNEG-720-G2

Date: 07-21-10

GSI GROUP



PNEG-720-G2

Model Number of My Sweep:

Date Delivered:

Date Installed:

NOTE: *The manufacturer reserves the right to improve its product whenever possible and practical to do so. We reserve the right to change, improve and modify products at any time without obligation to make changes, improvements and modifications on equipment sold previously.*

Personnel operating or working around this equipment should read this manual. This manual must be delivered with equipment to its owner. Failure to read this manual and its safety instructions is a misuse of the equipment. Any misuse of the equipment may void the warranty.

Contents

Chapter 1 Safety	5
Safety Guidelines	5
Safety Instructions	6
Operator Qualifications	10
Chapter 2 Safety Decals	11
Chapter 3 Introduction	15
Product Introduction	15
Chapter 4 General Product Information	17
Product Information	17
General Information	17
Capacities and Specifications	19
Q-D Bushings - Reverse Mounting	23
Chapter 5 Assembly	25
Back Shield Assembly	25
Flighting Assembly	27
Hanger Bracket Assembly	28
Flange Bearing Assembly	29
Gear Reducer Assembly	29
Drive Axle Assembly and Bearing Support	30
Install Reducer Mounting Plate and Reducer	32
Key Alignment	33
Install Tractor Drive Motor	34
Guard Assembly	35
Tractor Wheel Assembly	37
Counterweight Placement	38
Channel Extension Kit for Sweeps Used in 72' Diameter Bins and Larger	39
Motor Jack and Base Assembly	40
Motor Installation	41
Sheave Installation	42
Electrical Assembly	44
Jack Support Assembly	50
Center Pivot Installation	52
Control Panel Setup	55
Calibration	60
Operation	61
Chapter 6 Start-up	62
Perform Pre-start Checks	62
Start the Auger	63
Chapter 7 Operation	64
Operating the Sweep Auger	64
Operating the Sweep Auger Control Panel	65
Chapter 8 Shut Down	66
Normal Shut Down	66
Emergency Shut Down	66
Storage Preparation	66
Chapter 9 Maintenance	67
Maintain the Auger	67
Lubrication	68

Table of Contents

Chapter 10 Control Panel Diagrams	74
Control Panel Schematic (460/3/60) Post-May 2010	74
Control Panel Schematic (460/3/60) Pre-June 2010	75
Control Panel Schematic (230/3/60) Pre-June 2010	76
Control Panel Schematic (380/3/50) Pre-June 2010	77
Chapter 11 Troubleshooting	78
FAQs	79
Chapter 12 Parts List	87
Main Auger Components	88
Flight Components	92
End Bearing Components	94
Auger Drive Components	96
Drive Assembly	98
Tractor Chain Guard Parts	100
Motor Mount Jack and Base Assembly (GC09993)	101
All 12" Sweep Jack Supports and 16" Jack Supports after 11-01-04	102
Old Style 16" Sweep Jack Support (Before 11-01-04)	104
Control Panel Components Pre-June 2010	106
Weight Extension Kit (GC08144)	109
Components	110
Chapter 13 Warranty	111

Safety Guidelines

This manual contains information that is important for you, the owner/operator, to know and understand. This information relates to protecting **personal safety** and **preventing equipment problems**. It is the responsibility of the owner/operator to inform anyone operating or working in the area of this equipment of these safety guidelines. To help you recognize this information, we use the symbols that are defined below. Please read the manual and pay attention to these sections. Failure to read this manual and its safety instructions is a misuse of the equipment and may lead to serious injury or death.



This is the safety alert symbol. It is used to alert you to potential personal injury hazards. Obey all safety messages that follow this symbol to avoid possible injury or death.



DANGER indicates an imminently hazardous situation which, if not avoided, will result in death or serious injury.



WARNING indicates a potentially hazardous situation which, if not avoided, could result in death or serious injury.



CAUTION indicates a potentially hazardous situation which, if not avoided, may result in minor or moderate injury.



CAUTION used without the safety alert symbol indicates a potentially hazardous situation which, if not avoided, may result in property damage.



NOTE indicates information about the equipment that you should pay special attention.

1. Safety

Safety Instructions

Our foremost concern is your safety and the safety of others associated with this equipment. We want to keep you as a customer. This manual is to help you understand safe operating procedures and some problems which may be encountered by the operator and other personnel.

As owner and/or operator, it is your responsibility to know what requirements, hazards and precautions exist, and to inform all personnel associated with the equipment or in the area. Safety precautions may be required from the personnel. Avoid any alterations to the equipment. Such alterations may produce a very dangerous situation, where SERIOUS INJURY or DEATH may occur.

This equipment shall be installed in accordance with the current installation codes and applicable regulations which should be carefully followed in all cases. Authorities having jurisdiction should be consulted before installations are made.

Follow Safety Instructions

Carefully read all safety messages in this manual and safety signs on your machine. Keep signs in good condition. Replace missing or damaged safety signs. Be sure new equipment components and repair parts include the current safety signs. Replacement safety signs are available from the manufacturer.

Learn how to operate the machine and how to use controls properly. Do not let anyone operate without instruction.

Keep your machinery in proper working condition. Unauthorized modifications to the machine may impair the function and/or safety and affect machine life.

If you do not understand any part of this manual or need assistance, contact your dealer.

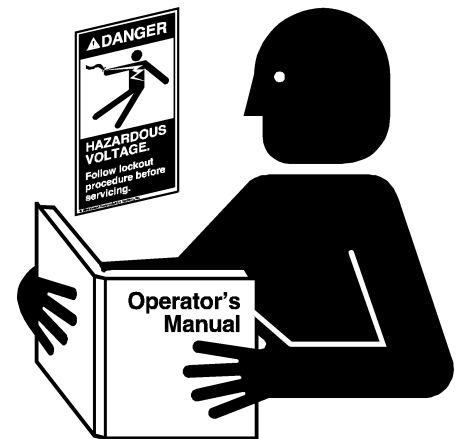

Read and Understand Manual

Keep Hands Away from Moving Parts

DO NOT put hand or arm in hopper. Rotating auger can crush and dismember.

DO NOT put any kind of tool inside hopper to try and clear debris while the auger is running. Damage to the equipment will result.

ALWAYS turn off and lock out all power sources before servicing equipment.

Keep all shields and covers in place during operation.



Rotating Auger

Operate Motor Properly

In an emergency, shut down the power source.

Turn OFF and lock out all power sources before performing any maintenance.

Do not operate electric motor equipped units until motors are properly grounded.

Disconnect power on electrical driven units before resetting motor overloads.

Do not repetitively stop and start the drive in order to free a plugged condition. Jogging the drive in this manner can damage the equipment and/or drive components.



Electric Shock Hazard

Practice Safe Maintenance

Understand service procedures before doing work. Keep area clean and dry.

Never lubricate, service, or adjust machine while it is in operation. Keep hands, feet and clothing away from rotating parts.

Keep all parts in good condition and properly installed. Fix damage immediately. Replace worn or broken parts. Remove any built up grease oil and debris.



**Maintain Equipment
and Work Area**

Prepare for Emergencies

Be prepared if fire starts.

Keep a first aid kit and fire extinguisher handy.

Keep emergency numbers for doctors, ambulance service, hospital and fire department near your telephone.

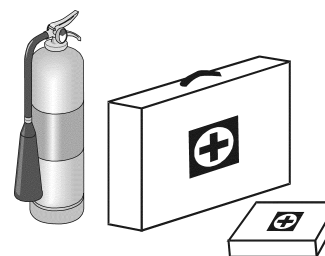

**Keep Emergency Equipment
Quickly Accessible**

1. Safety

Wear Protective Clothing

Wear close fitting clothing and safety equipment appropriate to the job.

Remove all jewelry.

Long hair should be tied up and back.

Safety glasses should be worn at all times to protect eyes from debris.

Wear gloves to protect your hands from sharp edges on plastic or steel parts.

Wear steel toe boots to help protect your feet from falling debris. Tuck in any loose or dangling shoe strings.

A respirator may be needed to prevent breathing potentially toxic fumes and dust.

Wear hard hat to help protect your head.

Wear appropriate fall protection equipment when working at elevations greater than six feet (6').

Eye Protection

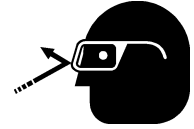

Gloves



Steel Toe Boots



Respirator



Hard Hat



Fall Protection



Operate Unload Equipment Properly



**Operate Unload
Equipment Safely**

- Untrained operators subject themselves and others to **SERIOUS INJURY** or **DEATH**. **NEVER** allow untrained personnel to operate this equipment.
- **NEVER** work alone.
- Keep children and other unqualified personnel out of the working area at **ALL** times. Refer to the **Start-Up** section of this manual for diagrams of the work area.
- Make sure **ALL** equipment is locked in position before operating.
- **NEVER** start equipment until **ALL** persons are clear of the work area.
- Keep hands and feet away from the auger intake and other moving parts.
- **NEVER** attempt to assist machinery operation or to remove trash from equipment while in operation.
- Be sure all operators are adequately rested and prepared to perform all functions of operating this equipment.
- **NEVER** allow any person intoxicated or under the influence of alcohol or drugs to operate the equipment.
- Make sure someone is nearby who is aware of the proper shut down sequence in the event of an accident or emergency.
- **ALWAYS** think before acting. **NEVER** act impulsively around the equipment.
- **NEVER** allow anyone inside a bin, truck or wagon which is being unloaded by an auger or conveyor. Flowing grain can trap and suffocate in seconds.
- Use ample overhead lighting after sunset to light the work area.
- Keep area around intake free of obstacles such as electrical cords, blocks, etc., that might trip workers.
- **NEVER** drive, stand or walk under the equipment.
- Use caution not to hit the auger when positioning the load.
- **ALWAYS** lock out **ALL** power to the equipment when finished unloading a bin.
- Be aware of pinch points. A pinch point is a narrow area between two surfaces that is likely to trap or catch objects and so is a potential safety hazard.

The images below show the location of the decals and safety signs which should appear on the Series II Sweep. *(Refer to Page 12-14 for decals.)*

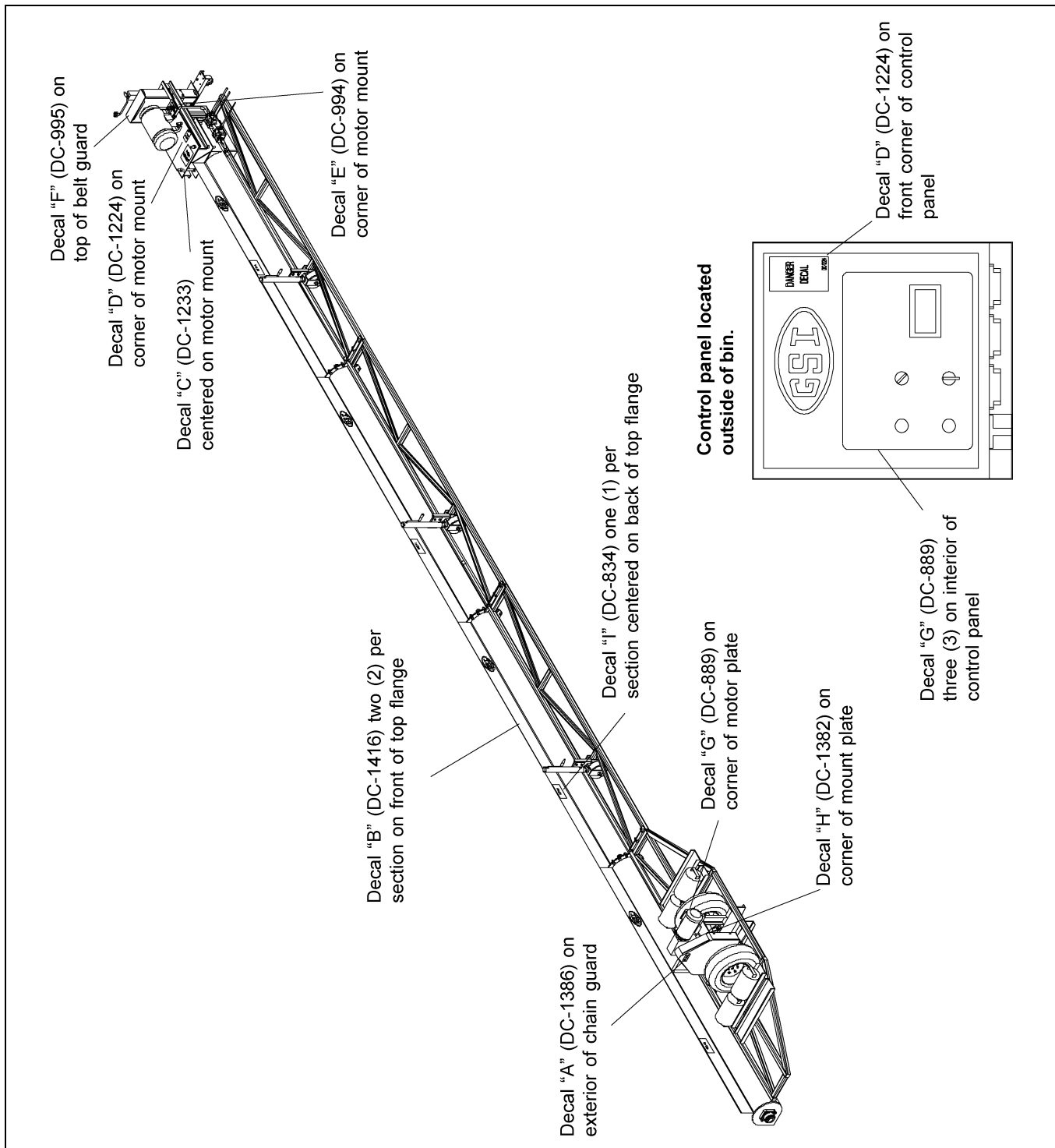

NOTE: Please remember safety signs provide important safety information for people working near bin unloading equipment that is in operation.

Any safety signs that are worn, missing, illegible or painted over should be replaced immediately. Obtain FREE replacements by contacting GSI.

2. Safety Decals



Decal "A"

Location: Exterior of chain guard
 Size: 2" x 4-1/2"
 Part No.: DC-1386



Decal "B"

Location: Two (2) per section on front of top flange
 Size: 4-5/16" x 5-7/16"
 Part No.: DC-1416

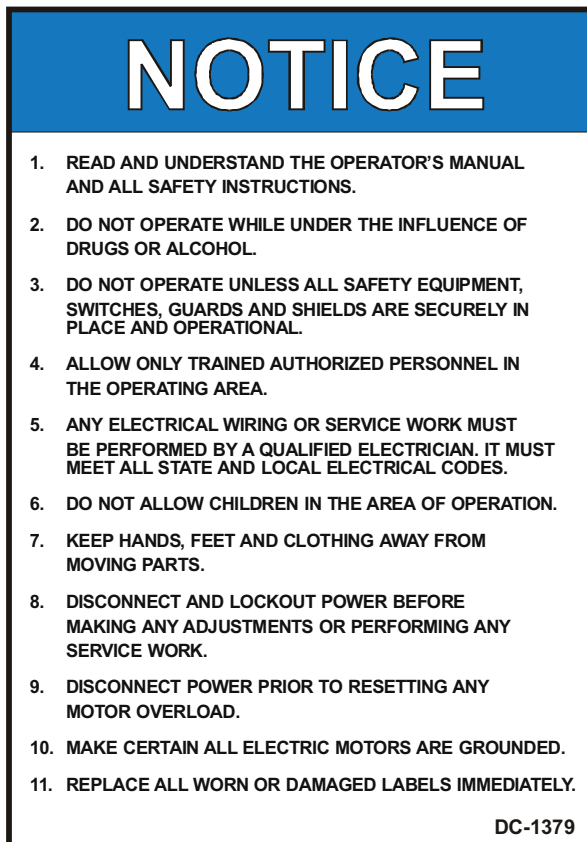

Decal "C"

Location: Centered on motor mount
 Size: 5-1/2" x 7-3/8"
 Part No.: DC-1379



Decal "D"

Location: Corner of motor mount
 Size: 2-7/8" x 5"
 Part No.: DC-1224

Figure 2A



Decal "E"

Location: Corner of motor mount
 Size: 4-1/2" x 2"
 Part No.: DC-994



Decal "F"

Location: Top of belt guard
 Size: 4-1/2" x 2"
 Part No.: DC-995



Decal "G"

Location: Corner of motor plate
 Size: 2-13/16" x 17/16"
 Part No.: DC-889



Decal "H"

Location: Corner of mount plate
 Size: 4" x 1-3/4"
 Part No.: DC-1382



Decal "I"

Location: One (1) per section centered on back of top flange
 Size: 9" x 3-3/4"
 Part No.: DC-834

Figure 2B

2. Safety Decals

- A. DANGER Sign No. DC-1395 was supplied with your bin unloading equipment. This safety sign should be applied to the side of the bin near the bin opening, so it will be viewed by people entering into the bin storage building. Do not cover any safety signs or any other signs that are already there.
- B. If the safety sign location suggested is not in full view because of equipment modifications, other equipment in the area or any reason, then locate the safety sign in a more suitable location.
- C. Be certain the surface is clean, dry and free of dirt and oil. Peel paper backing from decals and stick into place. The adhesive backing will bond on contact.

NOTE: *Please remember, safety signs provide important safety information for people working near bin unloading equipment that is in operation.*

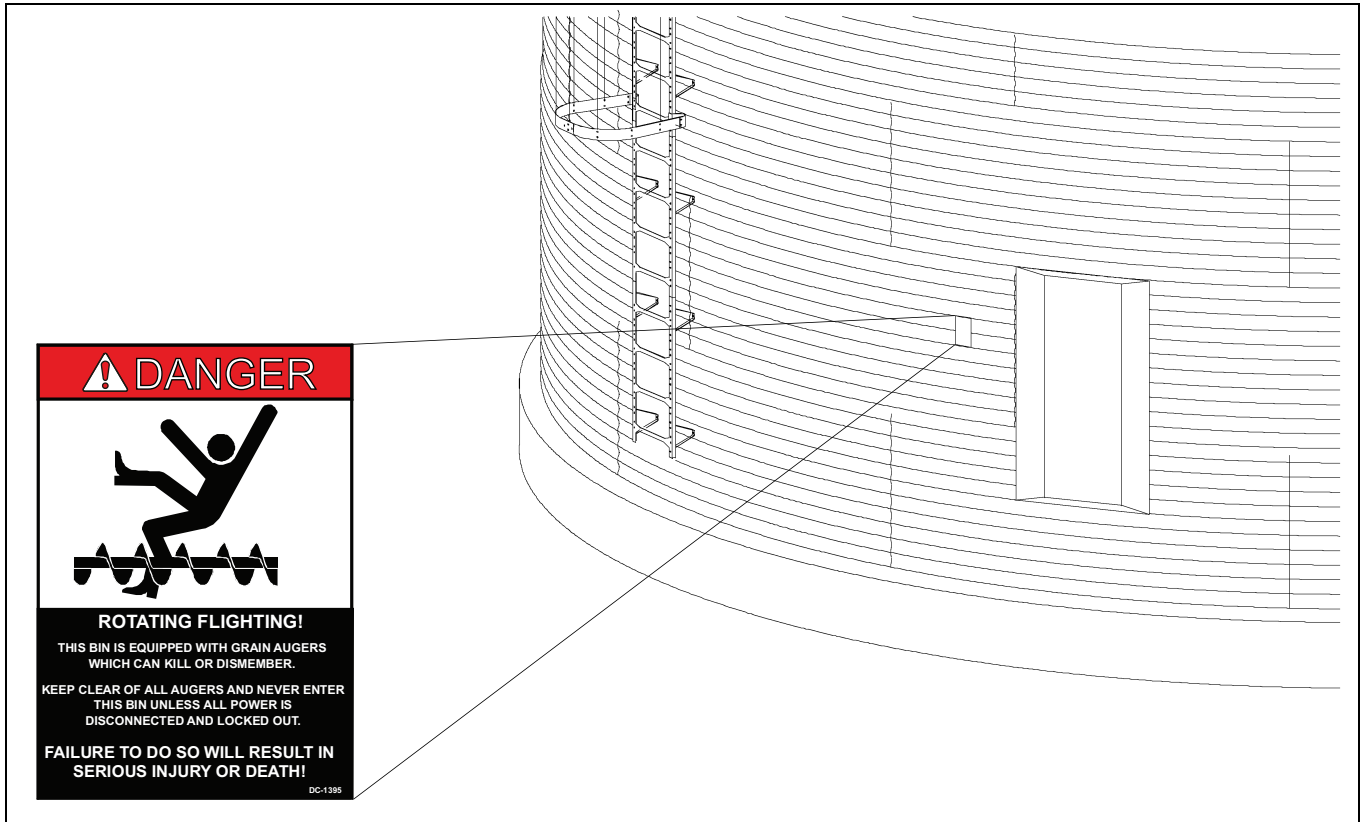

Figure 2C

NOTE: *If the Safety Sign cannot be easily read for any reason or has been painted over, replace it immediately. Additional Safety Signs may be obtained free of charge from your dealer, distributor or ordered from the factory.*

Order SAFETY SIGN NO. DC-1395.

Product Introduction

Congratulations! Your selection of the GSI Series II Sweep is a wise investment. It will give you years of dependable service. The main function of the Series II Sweep is to clean out the remaining grain, from the bin, after all gravity unloading has finished. The GSI Series II Sweep is a single pass sweep only. The unit will only operate in a round grain bin equipped with a center sump in the bin floor. **NOTE:** *The bin manufacturer should be contacted for their recommendations on your bin's structural integrity. The following are sweep criteria recommendations.*

Issues	Recommendations
Flooring	A track is required under each of the sweep tires and jack wheels where they travel over the aeration (steel) floor. This is the case for all steel flooring including full floor and flush floor aeration. The track should be a minimum of 10 Ga. thick and made from steel. The steel can be galvanized for the jack wheel paths but needs to have a non-slip coating for the drive tire paths. The drive tire track coating must not be course enough to damage the drive tires. A Chart on Page 18 is included that shows radius dimensions locating the points of contact between the sweep and the bin floor. The dimensions may be used to figure the material quantities of track to support the sweep across the aeration flooring. The track material is not supplied with the sweep and must be supplied by the installer or purchased from GSI. The dimensions are approximate and the assembled sweep should be checked for exact points of contact.
Center Sump Size	<p>When installing a 12" standard sweep, the minimum recommended opening is 36" x 36". With a 16" standard sweep, it is 42" x 42". If installing a sump with collector ring, the opening will be 42" x 42" for both sweep sizes.</p> <p>The sump hopper supplied by GSI was designed with sufficient clearance around the collector ring housing to allow grain to gravity flow through the hopper and be carried away by the material handling equipment below. 42-3/4" is the maximum opening size to allow rolling clearance for the casters assembled to the head end jack. If made smaller, grain flow may be decreased to an unacceptable level.</p> <p>**Flow of grain is limited to 15,000 BPH when using this sump and collector ring housing assembly. The collector ring housing extends 22-1/2" down from the floor surface and is approximately 14-1/4" x 14-1/4" in size.</p>
Number of Intermediate Sumps	<p>Intermediate sump pumps must be installed on a maximum of 10' centers where the sweep will be parked during storage. The first intermediate sump should be placed at a maximum of 10' from the center sumps and the end sump should be no more than 4' from the bin wall.</p> <p>The extra sumps will help clean out the grain in front of the sweep, reducing the start-up load. Doing this will save labor dollars and hours of work to dig out the sweep and will help the sweep during start-up. The sweep is not designed to start-up when submerged in material. The sweep should be parked behind the intermediate sumps with sumps on the auger side of the sweep.</p>
Routing the Power Supply to the Sweep	There are three (3) options for routing the power. The most common option is to run the cords out the door in the sidewall. Another option is to use the hopper sump with collector ring. This allows the power to be transferred through a mechanical device in the center sump and does not twist any cords. The third option is to use the pivot kit, which routes the power cord through the center sump. Using this kit requires the sweep to be backed up to the start point after sweeping. The pivot kit is not the preferred choice due to the repeated cord twisting.
Floor Level Tolerance	The top edge of the sump hopper and the top edge of the "X" brace support must be level with the floor. The floor must be level within 3/4" plus (or) minus, preferably less. Any high or low points must be gradually sloped. The change in elevation should be no more than 3/4" over 60".

3. Introduction

Issues	Recommendations
Bin Roundness Tolerance	Diameter tolerances are limited by foundation limits and sweep operation as well as structural issues. For 72' diameter and larger, the overall tolerance would be plus or minus 1-1/4" on the radius, plus or minus 1" on 42'-66' diameter bins and plus or minus 3/4" on 30'-39' bins.
Bin Opening Size Required for Installation	<p>The tail section is the largest piece of a standard Series II Sweep. The dimensions for a 16" tail section are 23-1/2" x 55-1/4". If the bin wall is not too thick, this unit should fit through a 23-1/2" x 47" opening. The dimensions for a 12" tail section are 21-1/4" x 51-1/2". Again, if the bin wall is not too thick, the section should fit through an opening 21-1/2 x 45".</p> <p>GSI offers a special Knock Down Sweep, uniquely designed for storage units with small doors. This sweep is broken into 10 main pieces that can fit through a door as small as 30-1/2" in diameter for 16", 27-1/2" in diameter for 12", or a 20" x 24" rectangular door. The components are then assembled inside the storage unit.</p>
Voltage Specification	The Series II Sweep is designed to operate using 460 Volt 3 Phase 60 Cycle Power . The voltage must be within plus or minus 4% for proper operation. Voltages outside of this range may cause excessive power draw or other operating problems. Please contact the factory for applications outside of these parameters.
Electrical Requirements	<p>Electrical controls and wiring should be installed by a qualified electrician. The motor disconnect switches and conductor cables should comply with the National Electric Code and any local codes which may apply.</p> <p>A main power disconnect switch capable of being locked only in the OFF position should be used. This has been integrated into the control panel after June of 2010. Disconnect and lock out the power before servicing the equipment, entering the bin, or resetting the motor overloads.</p> <p>The control panel MUST be mounted OUTSIDE the bin near the door. It must be located so the operator has a full view of the equipment and can see that all personnel are clear. It must NEVER be installed inside the bin. The foot switch has to be plugged into the control panel and depressed before the sweep is operational. It has a 10' cord so the sweep can only be monitored from OUTSIDE the bin. The thermal protection cord must also be wired into or plugged into the control panel before the sweep will operate.</p>

Product Information



This Series II Sweep is a single pass sweep. Consult the manufacturer of your storage tank regarding the requirements or restrictions of the sweeping process. The manufacturer may require a multiple pass sweep.

A. The Series II Sweep includes the following components.

Control Panel

Two (2) Motors

Motor Covers

Motor Mount

Auger Flighting

Auger Back Shield Assembly

Jack Supports

B. The unit will operate only in a round grain bin equipped with a center sump in the bin floor.



NEVER enter a grain bin unless ALL power driven equipment has been shut down. Disconnect and lock out power before entering the bin or servicing the equipment.

General Information

A. GSI reserves the right to improve its product whenever possible and practical to do so. We reserve the right to change, improve and modify products at any time without obligation to make changes, improvements and modifications on equipment sold previously.

B. This new bin sweep auger has been engineered and manufactured to give years of dependable service. The care and maintenance of this equipment will affect the satisfaction and service obtained. By following the instructions and recommendations, the owner should receive quality service for many years. If additional information or assistance is required, please contact GSI.

C. It is important to check both the quantity of parts and their descriptions with the packing list enclosed within each package. All claims for freight damage or shortage must be made by the consignee within ten (10) days of the date of the occurrence. The consignee should accept the shipment after noting the damage or loss on the bill of lading.

4. General Product Information

D. The [Chart below](#) shows radius dimensions locating the points of contact between the sweep and the bin floor. The dimensions may be used to figure material quantities of track to support the sweep across the aeration flooring. The track material is not supplied with the sweep and must be supplied by the installer. The dimensions are approximate and the assembled sweep should be checked for exact points of contact.

Radius Dimensions From Center of Bin								
Bin Dia.	Number of Sections	Head Jack Wheel 2" Wide	Intermediate Jack Wheel 3" Wide	Intermediate Jack Wheel 3" Wide	Inside Tire 8" Wide	Outside Tire 8" Wide	End Caster 16" Only 2" Wide Wheel	Extension End Caster 2" Wide Wheel
36'	2	36"			109"	139"	198"	
37'	2	44"			121"	151"	210"	
39'	2	52"			133"	163"	222"	
40'	2	52"			133"	163"	222"	
42'	2	60"			145"	175"	234"	
43'	2	64"			157"	187"	246"	
45'	2	64"			157"	187"	246"	
48'	2	84"			181"	211"	270"	
49'	2	84"			181"	211"	270"	
51'	2	92"			193"	223"	282"	
54'	3	64"	144"		217"	247"	306"	
55'	3	64"	144"		217"	247"	306"	
57'	3	76"	156"		229"	259"	318"	
59'	3	84"	168"		241"	271"	330"	
60'	3	92"	180"		253"	283"	342"	
62'	3	92"	188"		265"	295"	354"	
63'	3	92"	188"		265"	295"	354"	
66'	3	92"	204"		289"	319"	378"	
68'	3	92"	212"		301"	331"	390"	
69'	3	92"	212"		301"	331"	390"	
72'	3	92"	228"		325"	355"	414"	
75'	3	92"	236"		337"	367"	426"	
78'	4	92"	212"	288"	361"	391"	450"	
80'	4	92"	220"	300"	373"	403"	462"	
81'	4	92"	220"	300"	373"	403"	462"	
84'	4	92"	236"	324"	397"	427"	486"	
87'	4	92"	236"	332"	409"	439"	498"	
88'	4	92"	236"	340"	421"	451"	510"	
90'	4	92"	236"	348"	433"	463"	522"	
91'	4	92"	236"	348"	433"	463"	522"	
92'	4	92"	236"	356"	445"	475"	534"	
95'	4	92"	236"	364"	457"	487"	546"	
98'	4	92"	236"	380"	481"	511"	570"	
105'	5	92"	236"	372"	469"	499"		608"
113'	5	92"	236"	380"	481"	511"		656"
120'	5	92"	236"	380"	481"	511"		704"

Capacities and Specifications



Electrical controls and wiring should be installed by a qualified electrician. The motor disconnect switches and conductor cables should comply with the National Electrical Code and any local codes. Locate reset and motor starting stations so the operator can see that all personnel are clear of the equipment.

A. Use the [Chart below](#) to determine the horsepower required.

NOTE: Sweep is not designed to start under full load.

Bin Diameter	12" Series II Sweep					16" Series II Sweep				
	Drive HP	Bushel/MT per Hour Horsepower			Length Pivot to End	Drive HP	Bushel/MT per Hour Horsepower			Length Pivot to End
		5000/125	6000/155	7000/180			8000/205	9000/230	10000/255	
36'	2	7.5	7.5	7.5	16.79' (5.12 m)	2	7.5	7.5	7.5	16.85' (5.14 m)
37'	2	7.5	7.5	7.5	17.79' (5.43 m)	2	7.5	7.5	7.5	16.85' (5.14 m)
39'	2	7.5	7.5	7.5	18.79' (5.73 m)	2	7.5	7.5	7.5	17.85' (5.44 m)
40'	2	7.5	7.5	7.5	18.79' (5.73 m)	2	7.5	7.5	7.5	18.75' (5.72 m)
42'	2	7.5	7.5	7.5	19.79' (6.04 m)	2	7.5	7.5	10	19.85' (6.05 m)
43'	2	7.5	7.5	7.5	20.79' (6.34 m)	2	7.5	7.5	10	19.85' (6.05 m)
45'	2	7.5	7.5	7.5	20.79' (6.34 m)	2	7.5	7.5	10	20.85' (6.36 m)
48'	2	7.5	7.5	7.5	22.79' (6.95 m)	2	7.5	10	10	22.85' (6.96 m)
49'	2	7.5	7.5	7.5	22.79' (6.95 m)	2	7.5	10	10	22.85' (6.96 m)
51'	2	7.5	7.5	10	23.79' (7.26 m)	2	7.5	10	10	23.85' (7.27 m)
54'	2	7.5	7.5	10	25.79' (7.86 m)	2	10	10	10	25.85' (7.88 m)
55'	2	7.5	7.5	10	25.79' (7.86 m)	2	10	10	10	25.85' (7.88 m)
57'	2	7.5	7.5	10	26.79' (8.17 m)	2	10	10	10	26.85' (8.18 m)
59'	2	7.5	7.5	10	27.79' (8.47 m)	2	10	10	15	27.85' (8.49 m)
60'	2	7.5	7.5	10	28.79' (8.78 m)	2	10	10	15	28.85' (8.79 m)
62'	2	7.5	7.5	10	29.79' (9.08 m)	2	10	10	15	29.85' (9.10 m)
63'	2	7.5	7.5	10	29.79' (9.08 m)	2	10	10	15	29.85' (9.10 m)
66'	2	7.5	7.5	10	31.79' (9.69 m)	2	10	15	15	31.85' (9.71 m)
68'	2	7.5	7.5	10	32.79' (10.00 m)	2	10	15	15	32.85' (10.01 m)
69'	2	7.5	7.5	10	32.79' (10.00 m)	2	10	15	15	32.85' (10.01 m)
72'	2	7.5	7.5	10	34.79' (10.61 m)	2	15	15	15	34.85' (10.62 m)
75'	2	10	10	10	35.79' (10.91 m)	2	15	15	15	35.85' (10.93 m)
78'	2	10	10	10	37.79' (11.52 m)	2	15	15	15	37.85' (11.54 m)
80'	2	10	10	10	38.79' (11.83 m)	2	15	15	15	38.85' (11.84 m)
81'	2	10	10	10	38.79' (11.83 m)	2	15	15	15	38.85' (11.84 m)
84'	2	10	10	15	40.79' (12.44 m)	2	15	15	15	40.85' (12.45 m)
87'	2	10	10	15	41.79' (12.74 m)	2	15	15	20	41.85' (12.76 m)
88'	2	10	10	15	42.79' (13.05 m)	2	15	15	20	42.85' (13.06 m)
90'	2	10	10	15	43.79' (13.35 m)	2	15	15	20	43.85' (13.37 m)
91'	2	10	10	15	43.79' (13.35 m)	2	15	15	20	43.85' (13.37 m)
92'	2	10	10	15	44.79' (13.66 m)	2	15	20	20	44.85' (13.67 m)
95'	2	10	15	15	45.79' (13.97 m)	2	15	20	20	45.85' (13.98 m)
98'	2	10	15	15	47.79' (14.57 m)	2	15	20	20	47.85' (14.58 m)
105'	3	15	15	20	50.79' (15.48 m)	3	20	20	20	50.85' (15.50 m)
113'	3	15	15	20	54.79' (16.70 m)	3	20	20	20	54.85' (16.72 m)
120'	3	15	15	20	58.79' (17.92 m)	3	20	20	20	58.85' (17.94 m)

Due to continual improvements, GSI designs and specifications are subject to change without notice.

4. General Product Information

NOTE: *The horsepower recommendations are for augering reasonably dry grain. High moisture grain (greater than 15%) will require greater power for maximum capacity.*

NOTE: *Sweep drive and carrier wheels require plates or track over aeration flooring for travel and supports not supplied with the sweep unit. Contact your installer or flooring provider for possible sources and details.*

- B. A magnetic starter should be used to protect the motor when starting and stopping. It should stop the motor in case of power interruption, conductor fault, low voltage, circuit interruption or motor overload. The motor must be restarted manually. Some motors have built-in thermal overload protection. If this is the type of motor being used, use only those with a manual reset.
- C. The motor starting controls must be located outside the bin. They must NEVER be installed on the Series II auger inside the bin.
- D. Disconnect and lock out the power before resetting motor overloads.
- E. Disconnect and lock out the power before entering the bin.
- F. Disconnect and lock out the power before servicing the equipment.
- G. Position the reset and motor starting controls so that the operators have full view of the equipment.



There should ALWAYS be two (2) people in the work area.

- H. Make sure electric motors are grounded.



A main power disconnect switch capable of being locked only in the OFF position should be used. It should be locked in the OFF position whenever work is being done on the Series II Sweep.

Torque values to be used when tightening the bolts on the Series II Sweep

It takes more force to tighten a 3/4-10 bolt than to tighten a 1/2-13 bolt because of its larger diameter. It also takes more force to tighten a Grade 8 bolt than it does to tighten a Grade 5 bolt because of the greater material strength. A bolt that is waxed or otherwise lubricated requires much less force to tighten. If the same amount of force is used with a lubricated bolt as with a non-lubricated bolt, the lubricated bolt often will break.

A Suggested Initial Tightening Torque is listed in the [Chart below](#).

Size	Grade #5 Assembly Torque		Grade #8 Assembly Torque	
	Dry	Lubricated	Dry	Lubricated
1/4-20	8 ft. lbs	75 in lbs	12 ft. lbs	9 ft. lbs
1/4-28	10 ft. lbs	86 in lbs	14 ft. lbs	10 ft. lbs
5/16-18	17 ft. lbs	13 ft. lbs	25 ft. lbs	18 ft. lbs
5/16-24	19 ft. lbs	14 ft. lbs	25 ft. lbs	20 ft. lbs
3/8-16	30 ft. lbs	23 ft. lbs	45 ft. lbs	35 ft. lbs
3/8-24	35 ft. lbs	25 ft. lbs	50 ft. lbs	35 ft. lbs
1/2-13	75 ft. lbs	55 ft. lbs	110 ft. lbs	80 ft. lbs
1/2-20	90 ft. lbs	65 ft. lbs	120 ft. lbs	90 ft. lbs
5/8-11	150 ft. lbs	110 ft. lbs	220 ft. lbs	170 ft. lbs
5/8-18	180 ft. lbs	130 ft. lbs	240 ft. lbs	180 ft. lbs
3/4-10	260 ft. lbs	200 ft. lbs	380 ft. lbs	280 ft. lbs
3/4-16	300 ft. lbs	220 ft. lbs	420 ft. lbs	320 ft. lbs
7/8-9	320 ft. lbs	320 ft. lbs	600 ft. lbs	460 ft. lbs
1-8	640 ft. lbs	480 ft. lbs	900 ft. lbs	680 ft. lbs
1 1/8-7	800 ft. lbs	600 ft. lbs	1280 ft. lbs	960 ft. lbs
1 1/4-7	1120 ft. lbs	840 ft. lbs	1820 ft. lbs	1360 ft. lbs
1 3/8-6	1460 ft. lbs	1100 ft. lbs	2380 ft. lbs	1780 ft. lbs
1 1/2-6	1910 ft. lbs	1460 ft. lbs	3160 ft. lbs	2360 ft. lbs

Diameter	Proof Load	Yield Strength	Tensile Strength	Proof Load	Yield Strength	Tensile Strength
1/4 to 3/4	85000	92000	120000	120000	130000	150000
3/4 to 1 1/2	74000	81000	105000			
Medium Carbon Stl, Quenched and Tempered			Carbon Alloy Stl, Quenched and Tempered			

Grade 5 Bolts

Grade 5 bolts are designated by three (3) slash marks on the head.

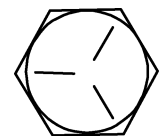

Grade 8 Bolts

Grade 8 bolts are designated by six (6) slash marks evenly spaced on the head of the bolt.

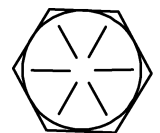

Under no condition shall any other fasteners be substituted for those supplied by the manufacturer.

4. General Product Information

Taper-Lock Bushings

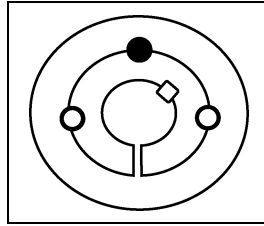

Figure 4A Number 1008 to 3030 Bushing



Wedging forces in the bushing saw slot, such as that exerted by a narrow edged regular screw driver, may damage or break the bushing. This damage would not be covered under the GSI warranty.



Do not lubricate the bushing taper, bushing bore, hub taper or the shaft. Doing so could result in breakage of the product.

Do not use worn hex key wrenches. Doing so may result in a loose assembly or may damage the screws.

To Install

1. Clean shaft, bore and outside of bushing and hub bore of all oil, paint and dirt. File away burrs.
2. Insert bushing in hub. Match the hole pattern, not threaded holes (each complete hole will be threaded on one side only).
3. Lightly oil set screws and thread into the half-threaded holes indicated as in [See Figure 4A](#).
4. Position the assembly onto the shaft allowing for the small axial movement which will occur during the tightening procedure.
5. Alternately torque set screws to recommended torque setting listed in the [\(See Chart.\)](#)
6. To increase the gripping force, hammer the face of the bushing using a drift or sleeve. (Do not hit the bushing directly with the hammer.)
7. Re-torque the screws after hammering.
8. Recheck the screw torques after the initial run-in, and periodically thereafter. Repeat [Steps 5, 6](#) and [7](#) if loose.

Recommended Installation Wrench Torque

Bushing No.	lb-in	Bushing No.	lb-in
1008, 1108	55	3535	1000
1210, 1215, 1310	175	4040	1700
1610, 1615	175	4545	2450
2012	280	5050	3100
2517, 2525	430	6050, 7060, 8065	7820
3020, 3030	800		

To Remove

1. Remove all screws.
2. Insert screws in hole or holes indicated on [See Figure 4A](#). Loosen the bushing by tightening the screw(s).

Q-D Bushings - Reverse Mounting

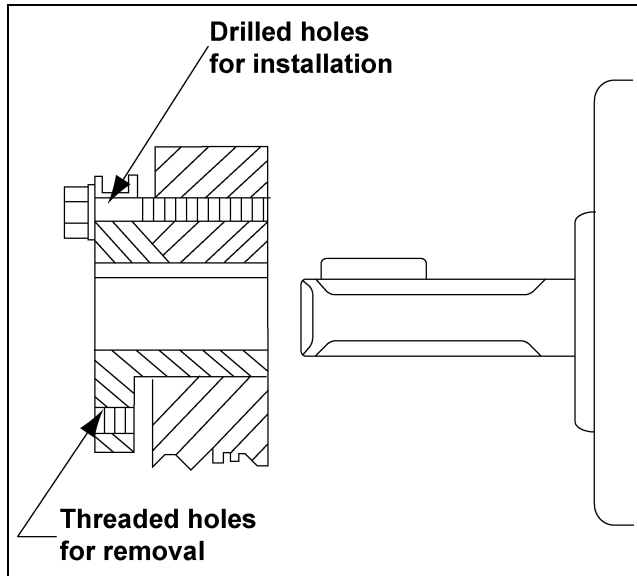

Figure 4B

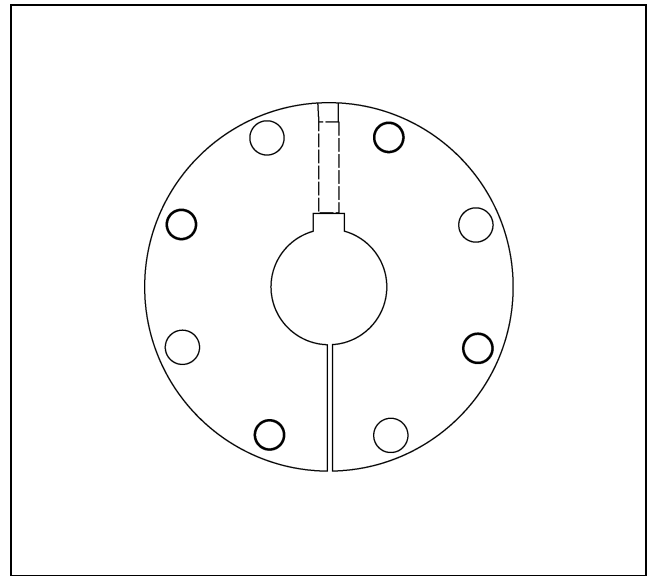

Figure 4C Overhead View of Q-D Bushing

To Install

1. Clean shaft, bore of bushing, outside of bushing and hub bore of all oil, paint and dirt. File away burrs.
2. Reverse Mounting: Place the bushing in hub and insert the cap screws through the drilled holes in the bushing flange. Tighten the cap screws, finger tight into threaded holes in the hub.
3. With the key on the shaft, slide the loosely assembled unit onto the shaft so that the cap screw heads are on the outside. Place the unit in the desired position on the shaft.
4. Tighten the cap screws alternately and evenly to the wrench torque specified in the [Chart below](#).

NOTE: When tightened, there will be a gap of 1/8" to 1/4" between the bushing flange and the hub. Should this gap be less, either undersize shafting or the wrong bushing shaft size was used.

5. Tighten the set screw (if supplied) over the key to the torque value listed in the [Chart below](#).

Recommended Installation Wrench Torque

Bushing	Cap Screw		Key Seat Set Screw	
	Size	lbs.-in	Size	lbs.-in
H	1/4"-20 x 7/8"	90	N/A	N/A
JA	#10-24 x 1"	60	N/A	N/A
SH	1/4"-20 x 1-3/8"	108	1/4"-20	87
SDS	1/4"-20 x 1-3/8"	108	1/4"-20	87
SD	1/4"-20 x 1-7/8"	108	1/4"-20	87
SK	5/16"-18 x 2"	180	1/4"-20	87
SF	3/8"-16 x 2"	360	3/8"-16	290
E	1/2"-13 x 2-3/4"	720	3/8"-16	290
F	9/16"-12 x 3-5/8"	900	3/8"-16	290
J	5/8"-11 x 4-1/2"	1620	1/2"-13	620
M	3/4"-10 x 6-3/4"	2700	1/2"-13	620

4. General Product Information

To Remove

1. Remove all cap screws.
2. Insert the cap screws into the threaded jack hole or holes.
3. Tighten all the jackscrews alternately and evenly beginning with the screw farthest from the bushing saw slot. Tighten until the bushing grip is released. Slide the unit off the shaft.



Do not lubricate the bushing taper, bushing bore, hub taper or the shaft. Doing so could result in breakage of the product.

Excessive screw torque may cause damage to either the bushing and/or the sheave. Uneven pressure on the jackscrews may also damage the bushing flange making removal difficult without damage to the bushing and/or sheave.

Do not use worn hex keys and/or wrenches. Doing so may result in a loose assembly or may damage the screws.

Back Shield Assembly

A. The sweep has been broken down into four (4) different section types: the head, intermediate, tail and extension sections.

NOTE: Use the [Chart below](#) to determine the identification and the order of assembly of the individual sweep sections.

12" Series II Sweep Sections									16" Series II Sweep Sections								
Bin Dia.	Sec.	Head	Int.	Int.	Int.	Tail	Ext.	Pivot to End	Bin Dia.	Sec.	Head	Int.	Int.	Int.	Tail	Ext.	Pivot to End
36'	2	52				149.5		16.79'	36'	2	52				150.25		16.85'
37'	2	64				149.5		17.79'	37'	2	52				150.25		16.85'
39'	2	76				149.5		18.79'	39'	2	64				150.25		17.85'
40'	2	76				149.5		18.79'	40'	2	76				150.25		18.85'
42'	2	88				149.5		19.79'	42'	2	88				150.25		19.85'
43'	2	100				149.5		20.79'	43'	2	88				150.25		19.85'
45'	2	100				149.5		20.79'	45'	2	100				150.25		20.85'
48'	2	124				149.5		22.79'	48'	2	124				150.25		22.85'
49'	2	124				149.5		22.79'	49'	2	124				150.25		22.85'
51'	2	136				149.5		23.79'	51'	2	136				150.25		23.85'
54'	3	100	60			149.5		25.79'	54'	3	100	60			150.25		25.85'
55'	3	100	60			149.5		25.79'	55'	3	100	60			150.25		25.85'
57'	3	112	60			149.5		26.79'	57'	3	112	60			150.25		26.85'
59'	3	124	60			149.5		27.79'	59'	3	124	60			150.25		27.85'
60'	3	136	60			149.5		28.79'	60'	3	136	60			150.25		28.85'
62'	3	136	72			149.5		29.79'	62'	3	136	72			150.25		29.85'
63'	3	136	72			149.5		29.79'	63'	3	136	72			150.25		29.85'
66'	3	136	96			149.5		31.79'	66'	3	136	96			150.25		31.85'
68'	3	136	108			149.5		32.79'	68'	3	136	108			150.25		32.85'
69'	3	136	108			149.5		32.79'	69'	3	136	108			150.25		32.85'
72'	3	136	132			149.5		34.79'	72'	3	136	132			150.25		34.85'
75'	4	136	144	60		149.5		40.79'	75'	4	136	144	60		150.25		40.85'
78'	4	136	108	60		149.5		37.79'	78'	4	136	108	60		150.25		37.85'
80'	4	136	120	60		149.5		38.79'	80'	4	136	120	60		150.25		38.85'
81'	4	136	120	60		149.5		38.79'	81'	4	136	120	60		150.25		38.85'
84'	4	136	144	60		149.5		40.79'	84'	4	136	144	60		150.25		40.85'
87'	4	136	144	72		149.5		41.79'	87'	4	136	144	72		150.25		41.85'
88'	4	136	144	84		149.5		42.79'	88'	4	136	144	84		150.25		42.85'
90'	4	136	144	96		149.5		43.79'	90'	4	136	144	96		150.25		43.85'
91'	4	136	144	96		149.5		43.79'	91'	4	136	144	96		150.25		43.85'
92'	4	136	144	108		149.5		44.79'	92'	4	136	144	108		150.25		44.85'
95'	4	136	144	120		149.5		45.79'	95'	4	136	144	120		150.25		45.85'
98'	4	136	144	144		149.5		47.79'	98'	4	136	144	144		150.25		47.85'
105'	5	136	144	132		144	53.5	50.79'	105'	5	136	144	132		144	54.25	50.85'
113'	5	136	144	144		144	89.5	54.79'	113'	5	136	144	144		144	90.25	54.85'
120'	5	136	144	144		144	137.5	58.79'	120'	5	136	144	144		144	138.25	58.85'



**The section sizes are total length given in inches. The head section has 8" subtracted from the shield length due to the pivot pipe location.
The 12" tail section has 5-1/2" added to the shield length due to the end shaft length.
The 16" tail section has 6-1/4" added to the shield length due to the end shaft length.**

5. Assembly

- B. **(All 16" Models and 12" Models with extensions)** Assemble the end caster to the end caster assembly using the 1/2" x 3-1/2" clevis pin and 1/8" pin clip as shown in [See Figure 5A](#).
- C. Attach the end caster assembly to the end of the tail section using two (2) 1"-8 hex nuts.

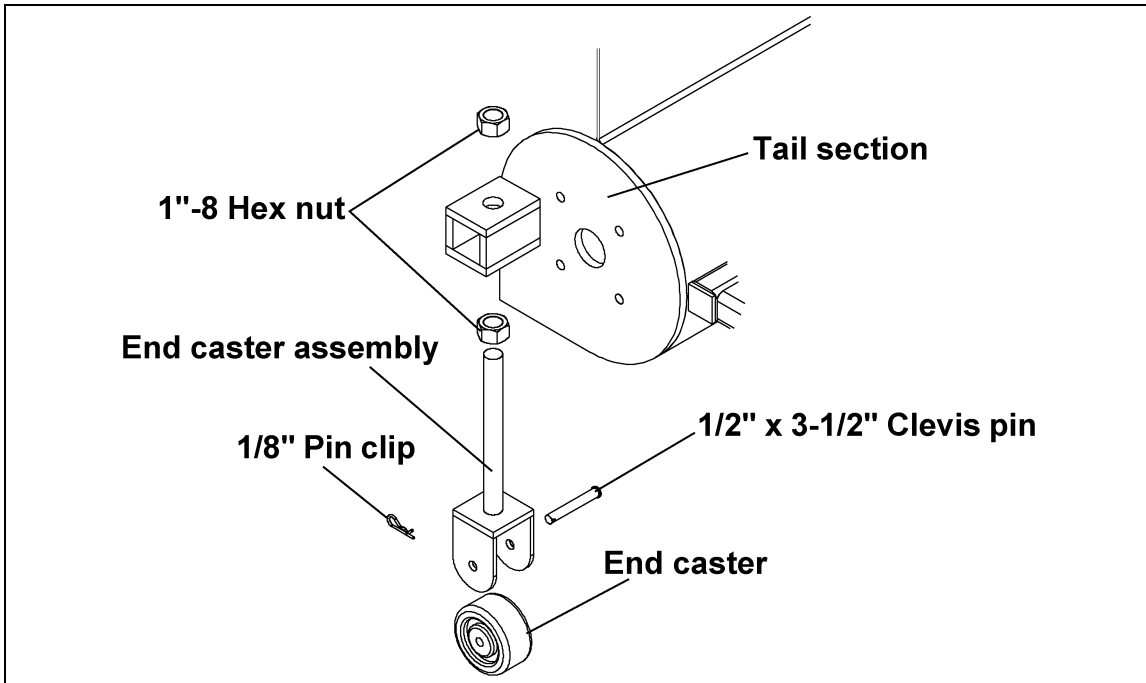

Figure 5A

- D. Use eight (8) 5/8"-11 x 1-3/4" grade 8 hex bolts, lock washers, and hex nuts at each section connection.



The bolts MUST be installed as shown in [Figure 5B](#).

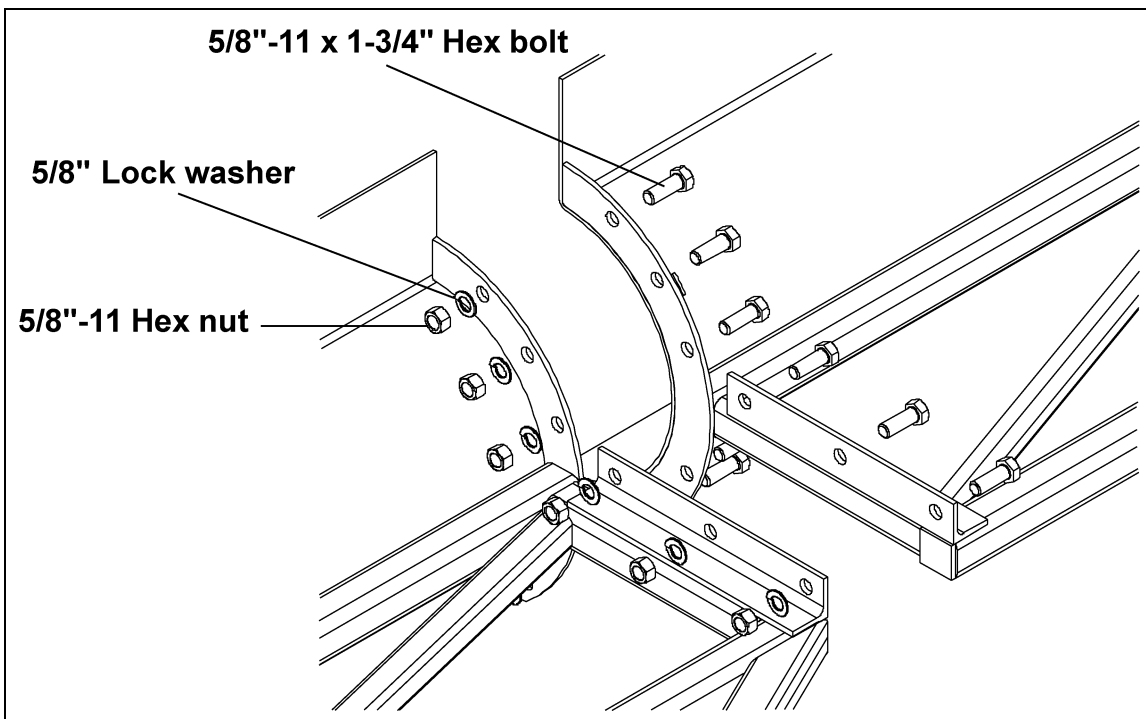

Figure 5B

Flighting Assembly

- A. Lay out the flight sections in order of assembly starting with the head flight working towards the tail flight.
- B. Using the connecting stubs, bolt the flight sections together with hex bolts and lock nuts. Make sure the flight ends are in time with each other.

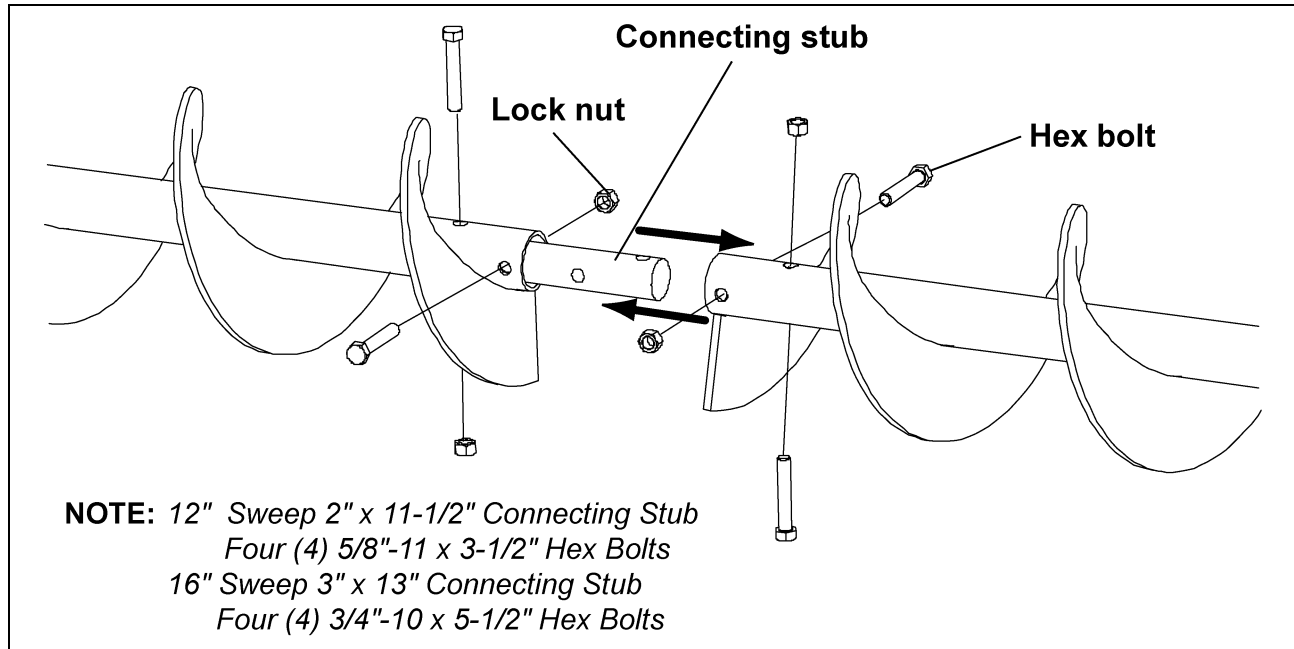

Figure 5C

- C. Slide the end stub through the bearing plate on the tail section and into the tail flight securing it with hex bolts and lock nuts.

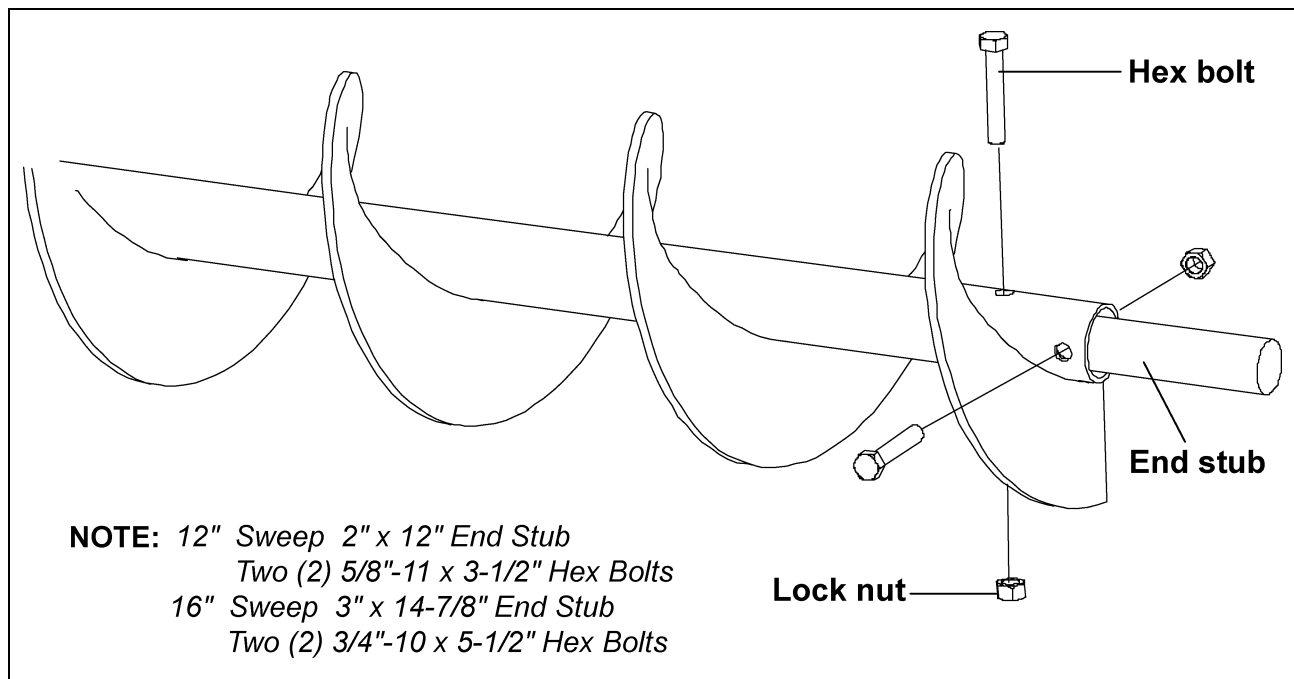

Figure 5D

Hanger Bracket Assembly

A. Bolt the nylon bearings and hanger brackets to the connecting stubs using hex bolts, lock washers, and hex nuts as shown in [See Figure 5E](#).

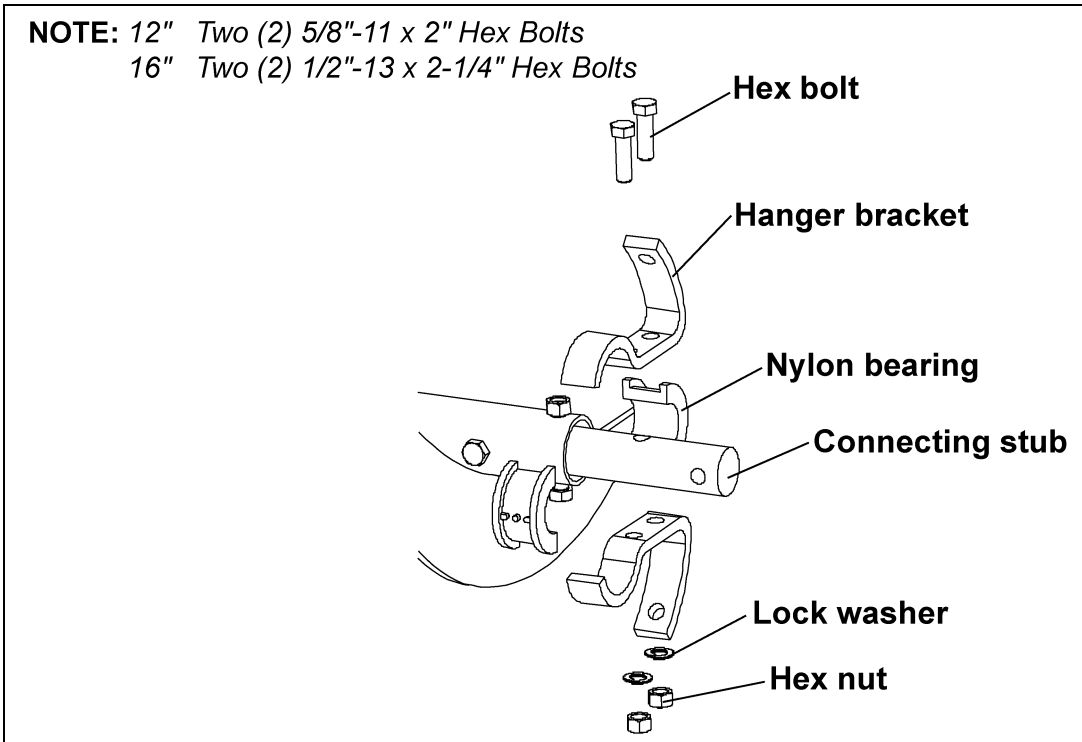

Figure 5E

B. Bolt the hanger brackets to the back shields using two (2) 5/8"-11 x 2" hex bolts, two (2) square washers, two (2) lock washers, and two (2) hex nuts as shown in [See Figure 5F](#).

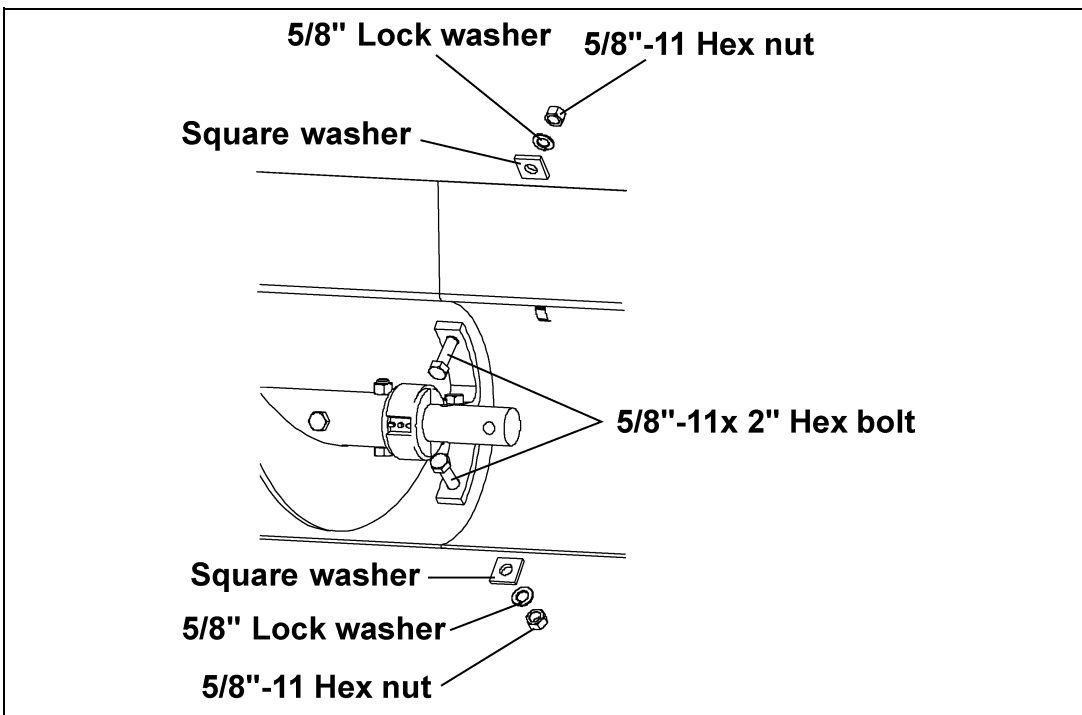

Figure 5F

Flange Bearing Assembly

A. Slide the flange bearing onto the end stub and bolt it to the end plate using hex bolts, lock washers and hex nuts as shown in [See Figure 5G](#).

NOTE: Do not tighten the set screws on the bearing at this time. This can be done after the gear reducer is installed.

NOTE: Caster assembly only used on 16" sweeps and 12" sweeps with extensions.

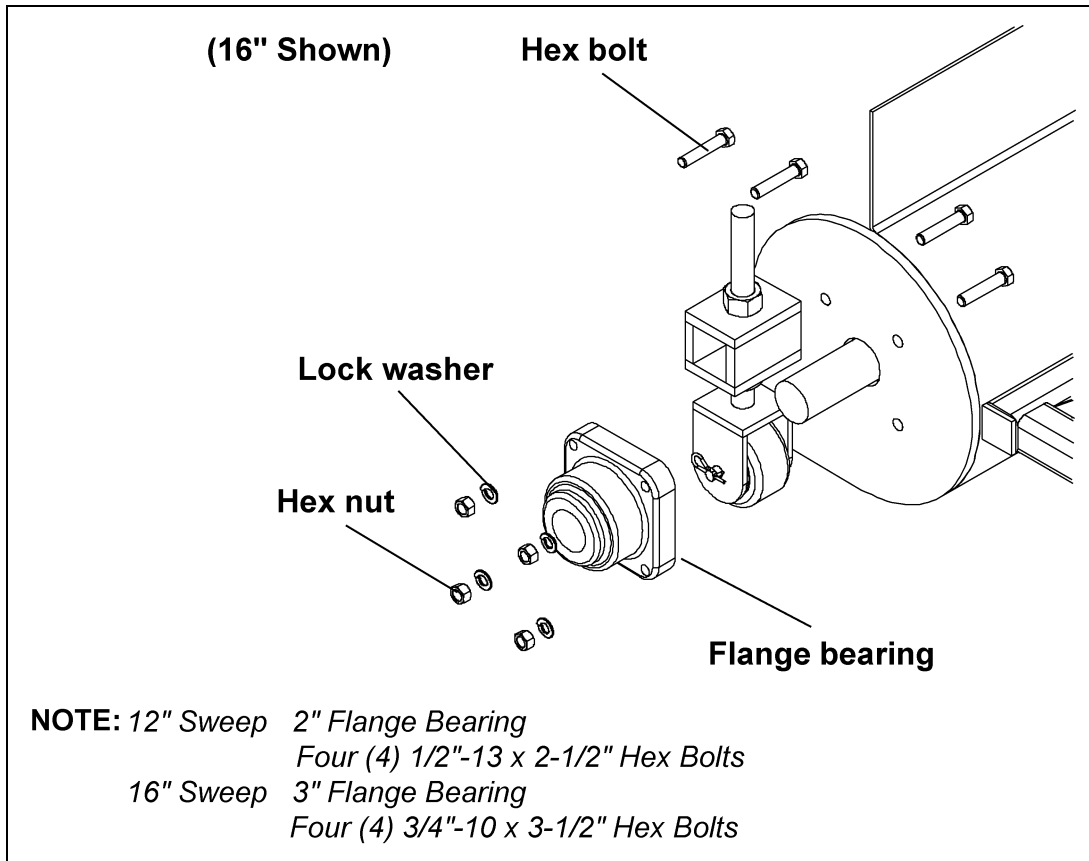

Figure 5G

Gear Reducer Assembly

A. Slide the output shaft of the reducer through the end plate of the head section and into the end of the head flight. Secure the Reducer Output Shaft to the Head Flight with hex bolts and lock nuts. ([See Figure 5H on Page 30.](#))

B. Bolt the reducer to the end plate of the head section using hex bolts, flat washers and lock washers, supplied with the reducer. ([See Figure 5H on Page 30.](#))

NOTE: The input shaft of the reducer **MUST** be to the top of the reducer. Refer to the owner's manual supplied with the reducer for proper vent plug, fill plug and drain plug locations.

5. Assembly

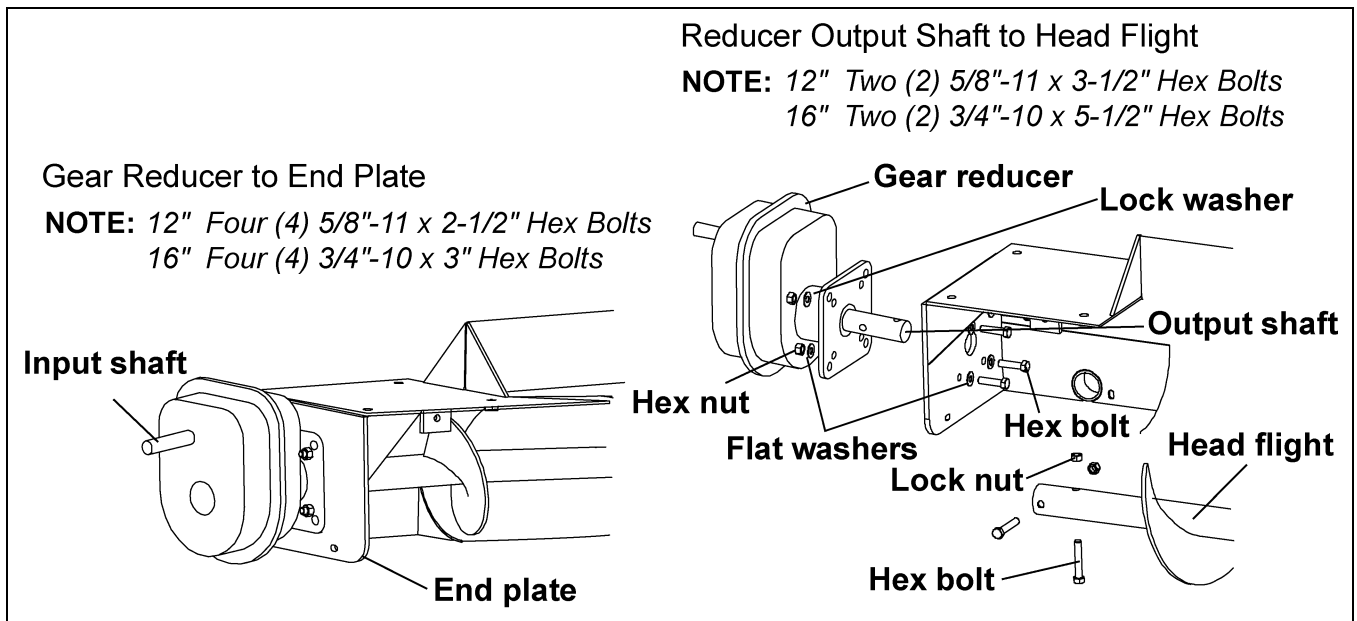

Figure 5H

CAUTION

The gear reducer is **NOT** filled with oil from the factory. For gear reducer specifications and oil fill recommendations, refer to the [Lubrication Section on Page 68](#) of this manual.

Drive Axle Assembly and Bearing Support

- A. Loosen set screws on bearings.
- B. Replace standard grease zerks with 90° grease zerks on both bearings. Make sure the 90° grease zerk is turned as shown in [Figure 5I](#), so the zerks are accessible from the center of the tractor drive stand.

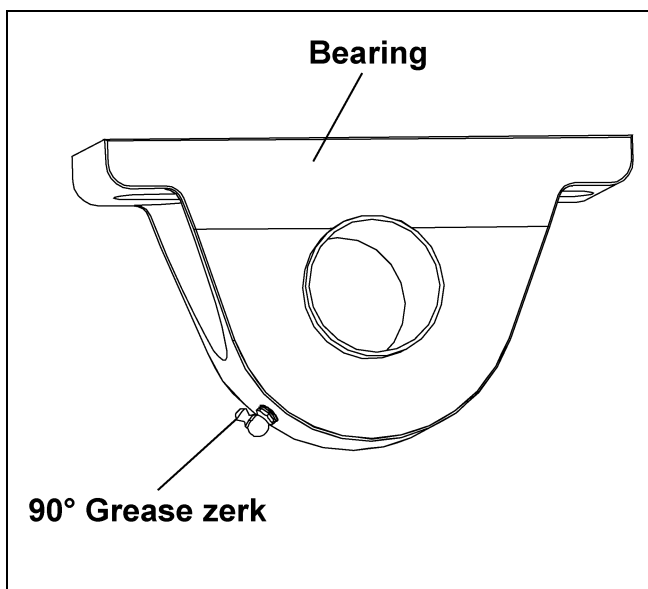

Figure 5I

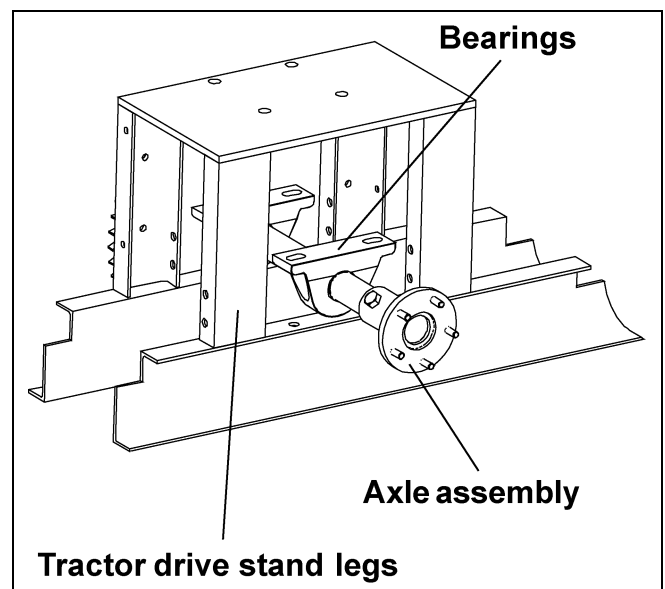

Figure 5J

- C. Slide the axle assembly between the legs of the tractor drive stand as shown in [Figure 5J](#).
- D. Rotate the pillow block bearings until the bases are facing up. (See [Figure 5J](#).)

E. Bolt the bearing support brackets to the legs of the tractor drive stand using 1/2" x 1-3/4" bolts, 1/2" lock washers, 1/2" bevel washers and 1/2" hex nuts. (See Figure 5K.)

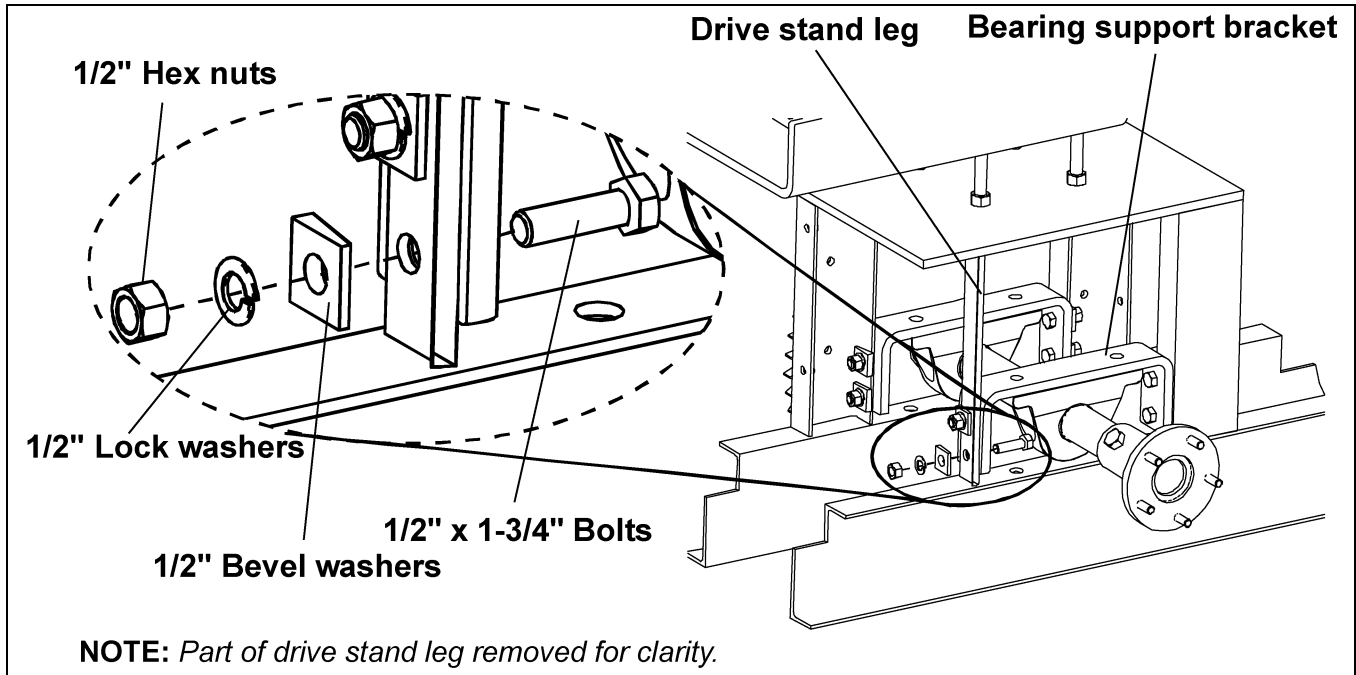

Figure 5K

F. Attach pillow block bearings to the bearing support brackets using 5/8" x 2-1/2" bolts, 5/8" lock and flat washers, and 5/8" hex nuts. (See Figure 5L.)

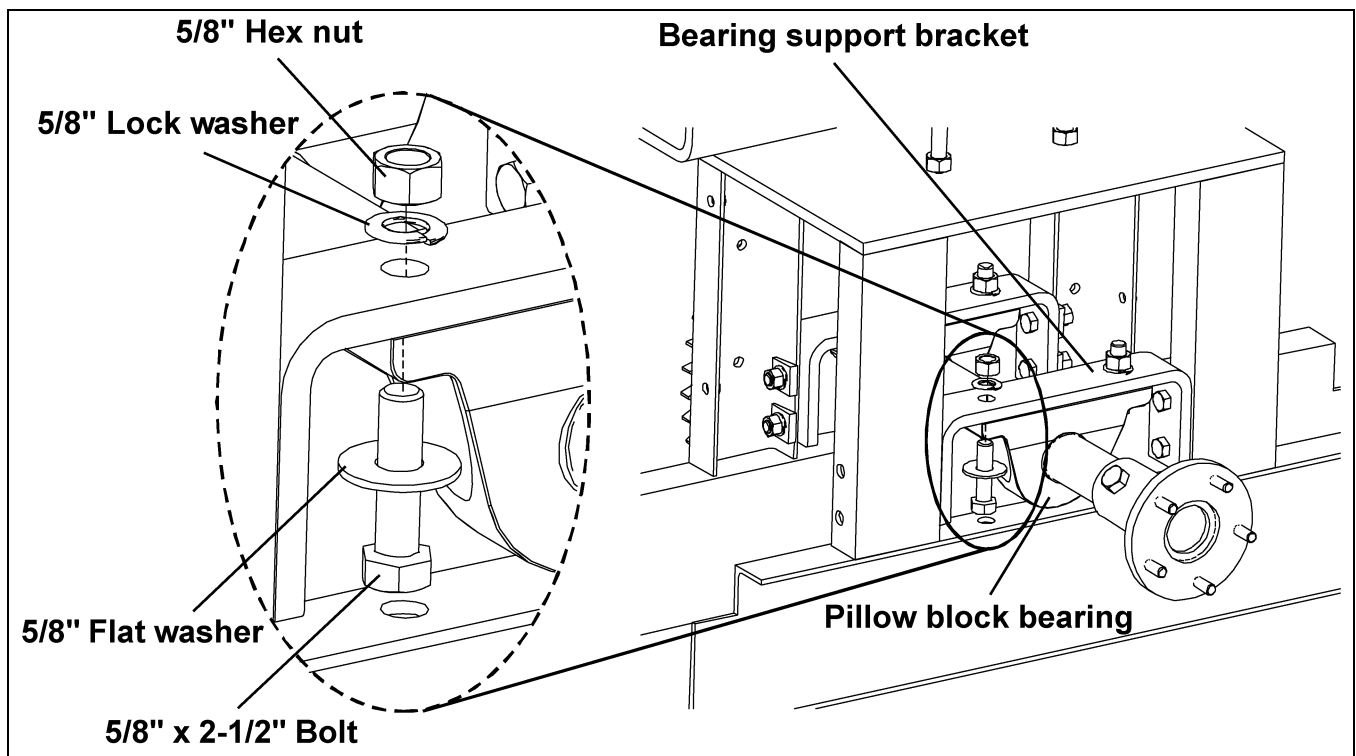

Figure 5L

G. Tighten set screws on pillow block bearings.

H. Tighten all hardware.

5. Assembly

Install Reducer Mounting Plate and Reducer

- A. Attach the C-Face reducer to the mounting plate using four (4) 1/2"-13 x 1-1/4" hex bolts and lock washers. (See Figure 5M.)
- B. Fasten the reducer mounting plate to the tail section plate using four (4) 5/8"-11 x 6" all-thread rods and sixteen (16) hex nuts. Adjust the mounting plate as close as possible to the tail section plate.



The gear reducer is NOT filled with oil from the factory. For gear reducer specifications and oil fill recommendations, refer to the owner's manual supplied with the reducer or the lubrication information in the [Lubrication Section](#) on Page 68 of this manual.

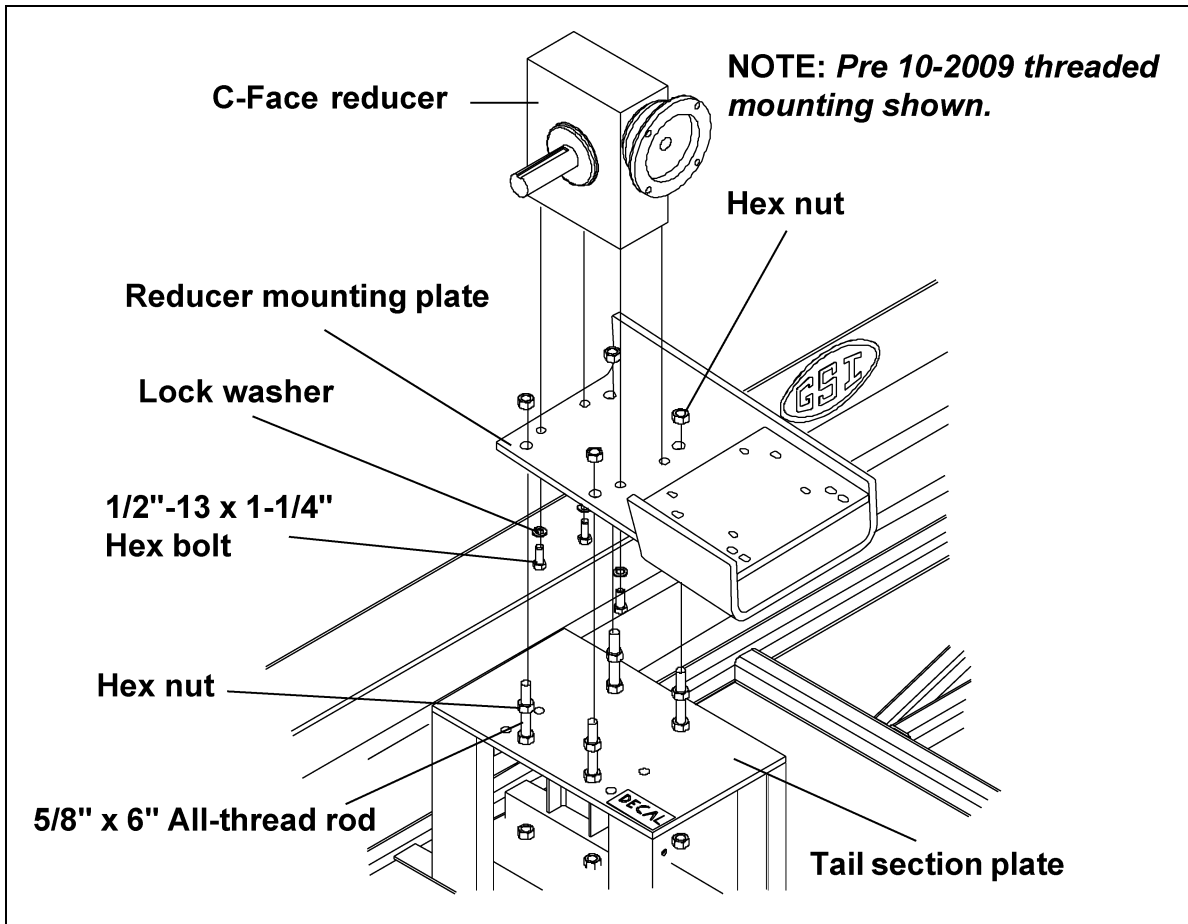

Figure 5M



The tractor drive gear reducer has a drain plug in the bottom of the housing. Make sure the drain plug is flush or slightly under the surface of the mounting face. If it is not, the plug will not allow the reducer to set flat on the mounting plate and could cause the motor to seize.

THIS TYPE OF DAMAGE IS NOT COVERED BY THE WARRANTY.

Key Alignment



All keys should be parallel to the drive shaft. If the key is not straight (parallel) the gear box quill sleeve will crack.

THIS TYPE OF DAMAGE IS NOT COVERED BY WARRANTY.

- A. Place key in keyway on drive shaft.
- B. Make sure key is flat (parallel to drive shaft) in keyway as in [Figure 5N_1](#) and [Figure 5N_2](#). **NOT** like [Figure 5N_3](#).

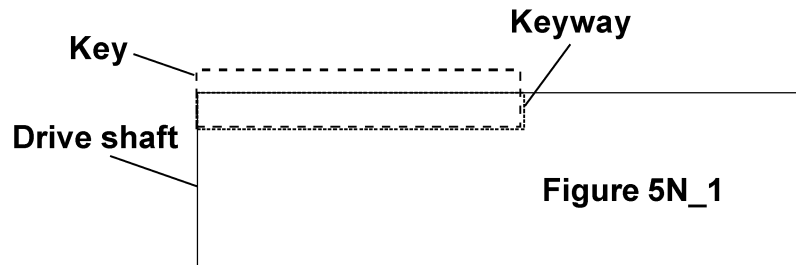

Key correctly positioned in a straight routed keyway. (Profiled keyway)

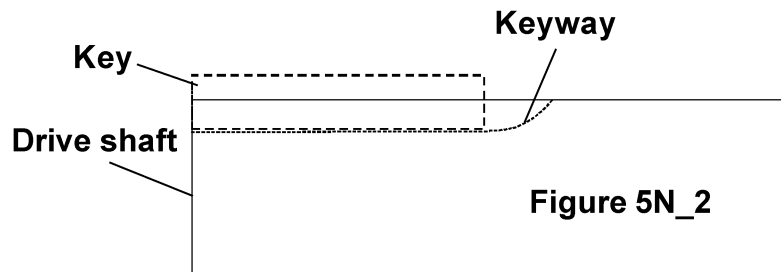

Key correctly positioned in a scalloped routed keyway. (Sled runner keyway)

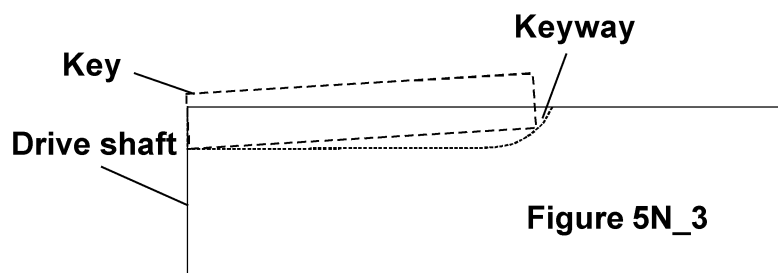

Key INCORRECTLY positioned in a scalloped routed keyway. Do not install key in this position.

Figure 5N

5. Assembly

C. Line up keyway on shaft with keyway on reducer and insert shaft into motor. (See Figure 50.)

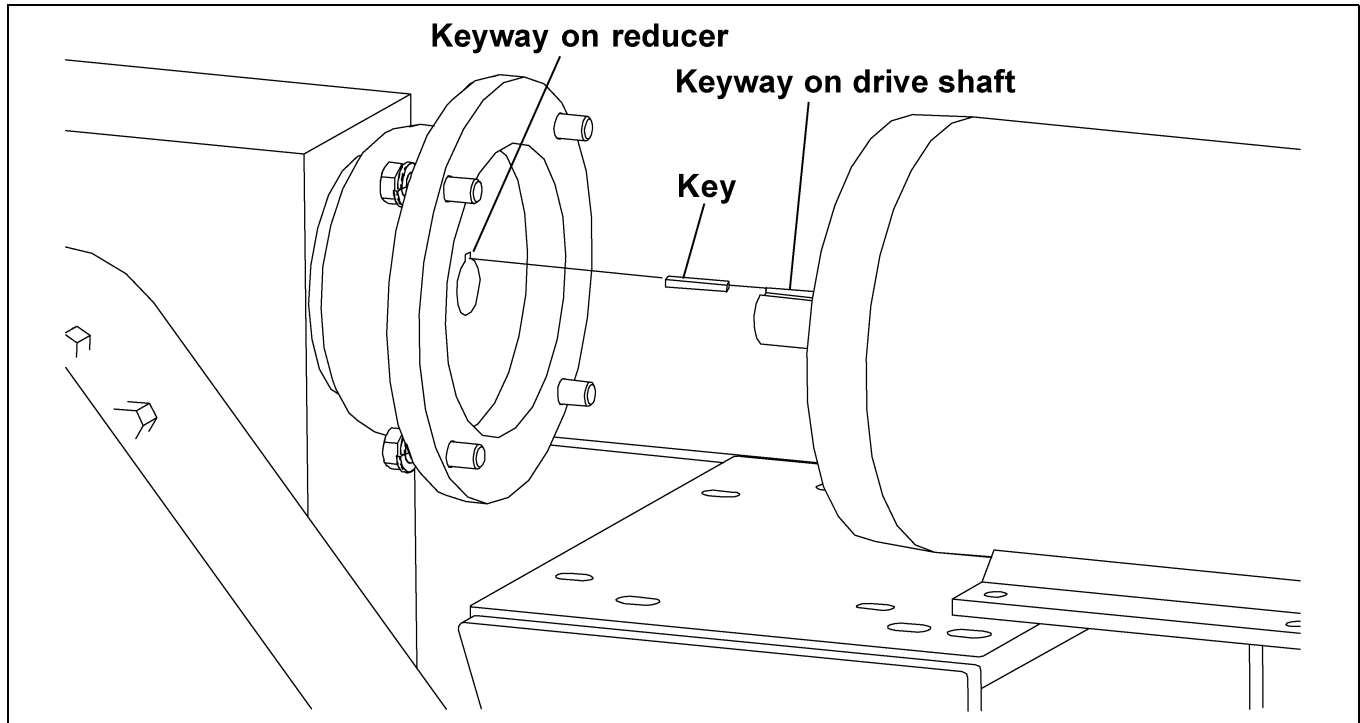

Figure 50

Install Tractor Drive Motor

A. Bolt the C-Face motor to the reducer using hex bolts, lock washers and a key. (See Figure 5P on Page 35.) (See the note on Page 35 for bolt size.)



Do not use the motor mounting bolts to pull the motor down to the motor mount plate. Instead, add shims GC09838 between the motor feet and the motor mount plate to fill any gap. If these shims are not used as required, the motor front bearing may be pushed out of alignment and the motor will lock up. If the gap seems unusually large, over 1/4", check to make sure the gear reducer is setting flat on its mounting base. The tractor drive gear reducer has a drain plug in the bottom of the housing. Make sure the drain plug is flush or slightly under the surface of the mounting face. If it is not, the plug will not allow the reducer to set flat on its mounting plate, causing damage to the motor.

THIS TYPE OF DAMAGE IS NOT COVERED BY WARRANTY.

NOTE: 56C Frame Four (4) 3/8"-16 x 1-1/4" Hex Bolts and 3/16" x 3/16" x 1" Key
143TC Frame Four (4) 3/8"-16 x 1-1/4" Hex Bolts and 3/16" x 3/16" x 1" Key
182TC Frame Four (4) 1/2"-13 x 1-1/4" Hex Bolts and 1/4" x 1/4" x 1" Key

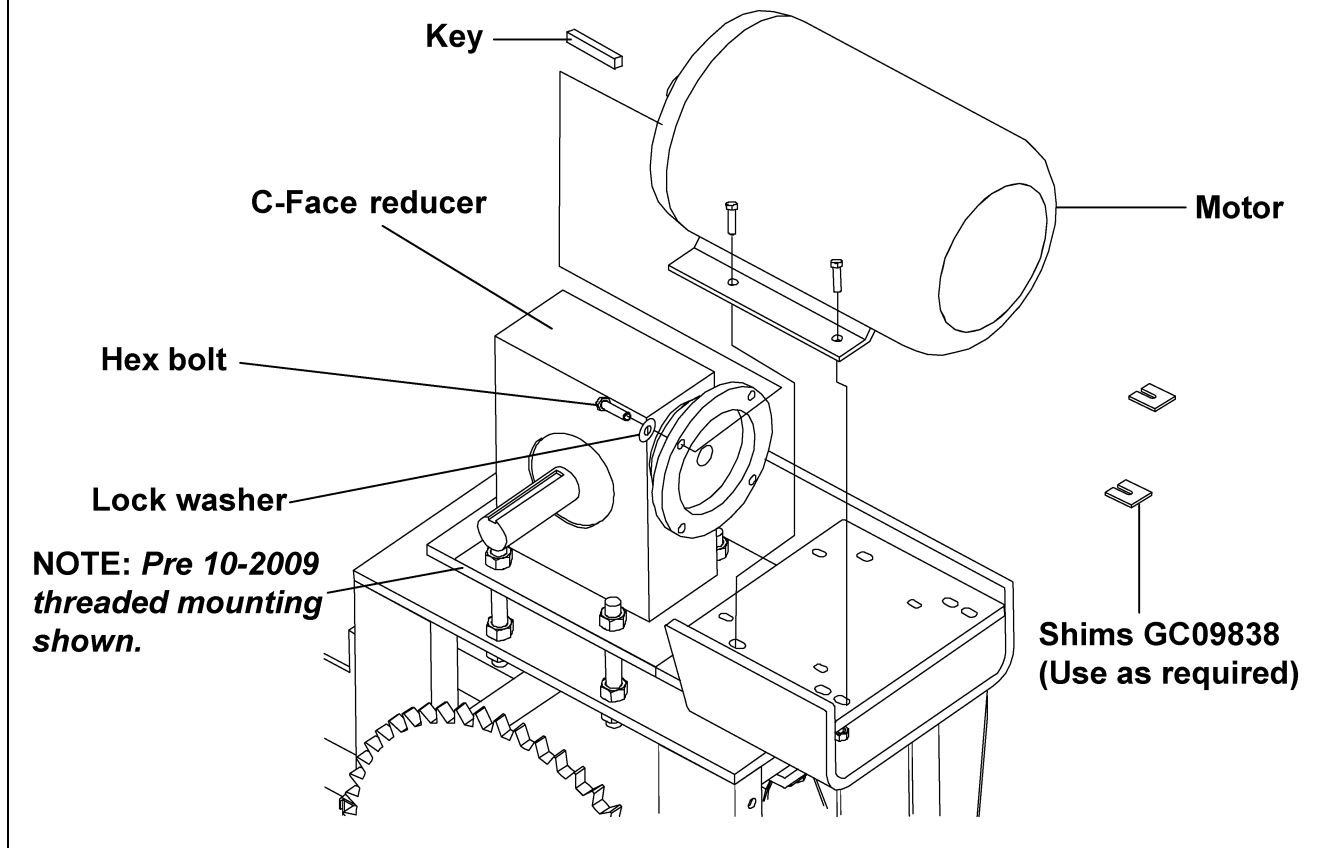

Figure 5P

Guard Assembly

- A. Attach the Guard Plate to the Tractor Drive Stand Legs using 3/8" bolts and nuts before attaching the drive sprocket. (See Figure 5Q on Page 36.)
- B. Slide the twelve tooth drive sprocket, bushing, and key (see key chart for your size key) onto the output shaft of the reducer, make sure both sprockets line up. (See Figure 5Q and Figure 5Q_A on Page 36.)
- C. Assemble the Bottom Chain Guard Trap to the Bottom Chain Guard Weldment using 1/2" x 3" HHCS bolts, 1/2" split lock washers, and 1/2" hex nuts. (See Figure 5P.)
- D. Attach Bottom Chain Guard Weldment to Tractor Drive Stand using 3/8" x 1-1/4" HHCS bolts, 3/8" split lock washers, and 3/8" hex nuts. (See Figure 5I on Page 30.)
- E. Attach Top Chain Guard Assembly to Tractor Drive Stand using 3/8" x 1" bolts, 3/8" split lock washers and 3/8" hex nuts. (See Figure 5Q on Page 36.)

5. Assembly

KEY CHART	
1 HP	- 5/16" x 2" Key
2 HP	- 3/8" x 3-3/4" Key
3 HP	- 3/8" x 3" Key

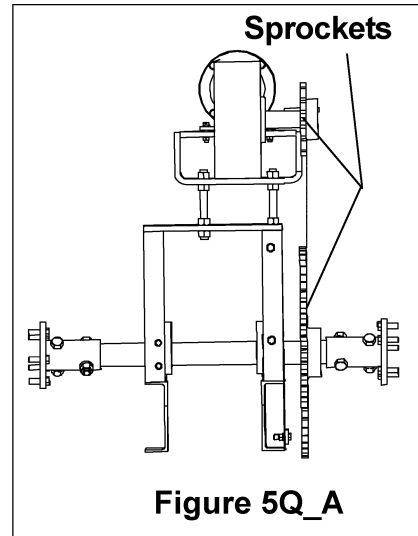
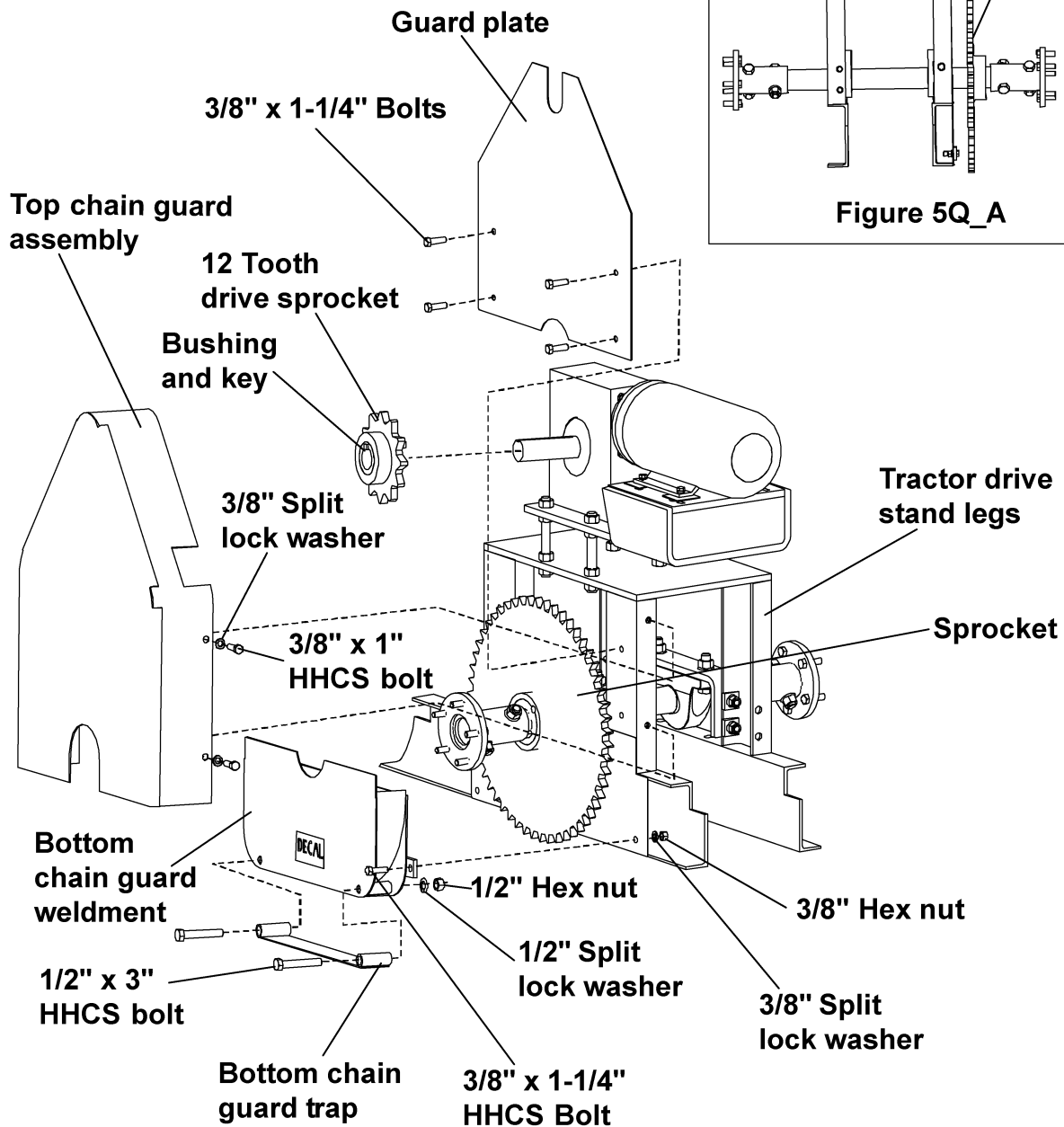

Figure 5Q



Wedging forces in the bushing saw slot, such as that exerted by a narrow edged regular screw driver, may damage or break the bushing. This damage would not be covered under the GSI warranty.

Tractor Wheel Assembly

A. Assemble the tires to the drive axle assembly using ten (10) 7/16" lock washers and hex nuts.
(See Figure 5R.)

NOTE: Tires go on backwards as shown in See Figure 5R.

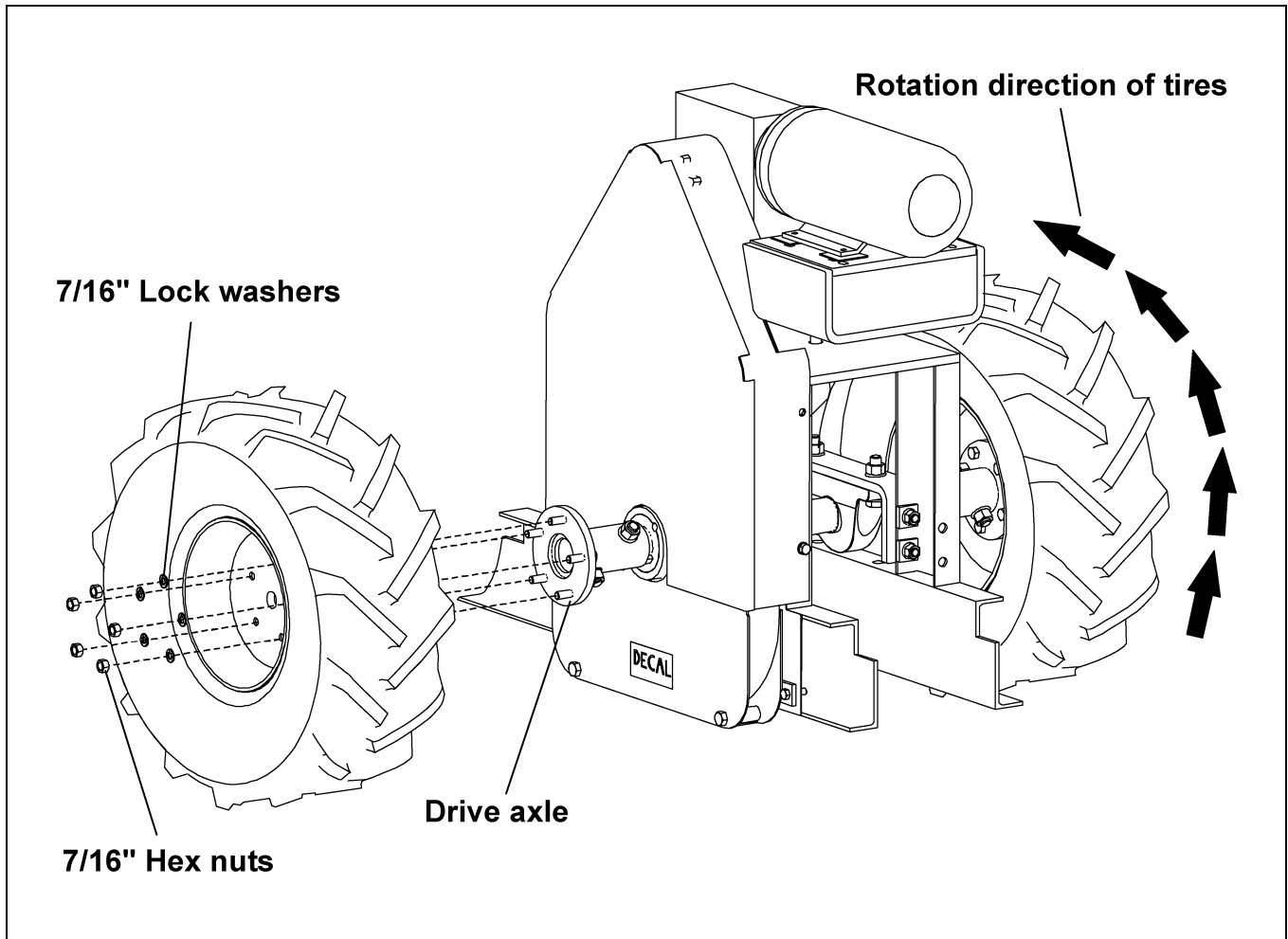

Figure 5R

Counterweight Placement

- A. Place an equal number of counterweights on each side of the drive assembly on the six inch (6") channels that are welded to the tail section.



Use proper lifting procedures and equipment when lifting counterweights. Each counterweight weighs 175 pounds.

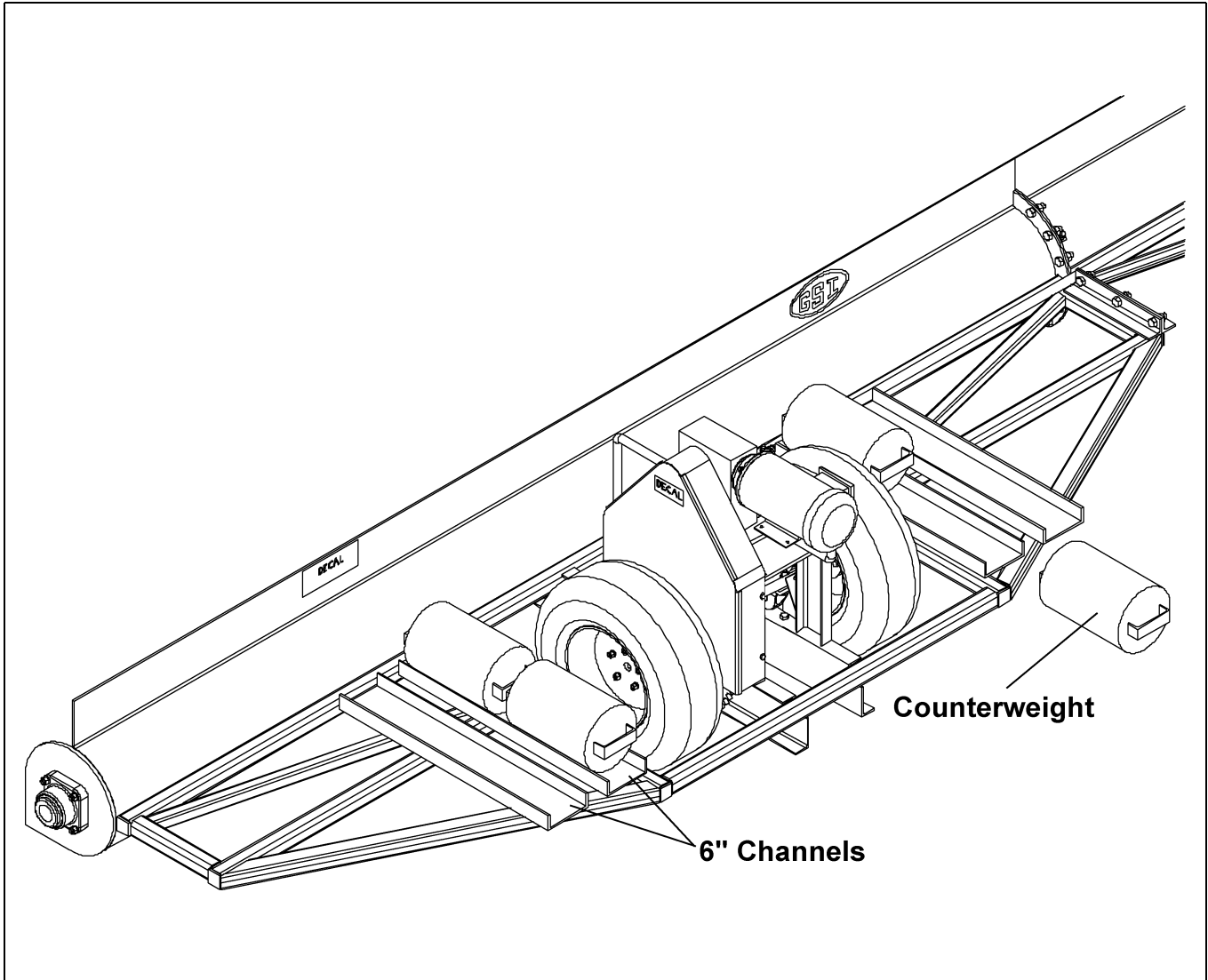

Figure 5S

Channel Extension Kit for Sweeps Used in 72' Diameter Bins and Larger

- A. 72' sweeps and larger need an extension kit installed.
- B. Attach the center weight weldments to the adjustable center weight channel using eight (8) 1/2" x 1-1/4" bolts, split lock washers and hex nuts. The adjustable center weight has three sets of holes for the center weight weldments to adjust the weights. (See Figure 5T.)

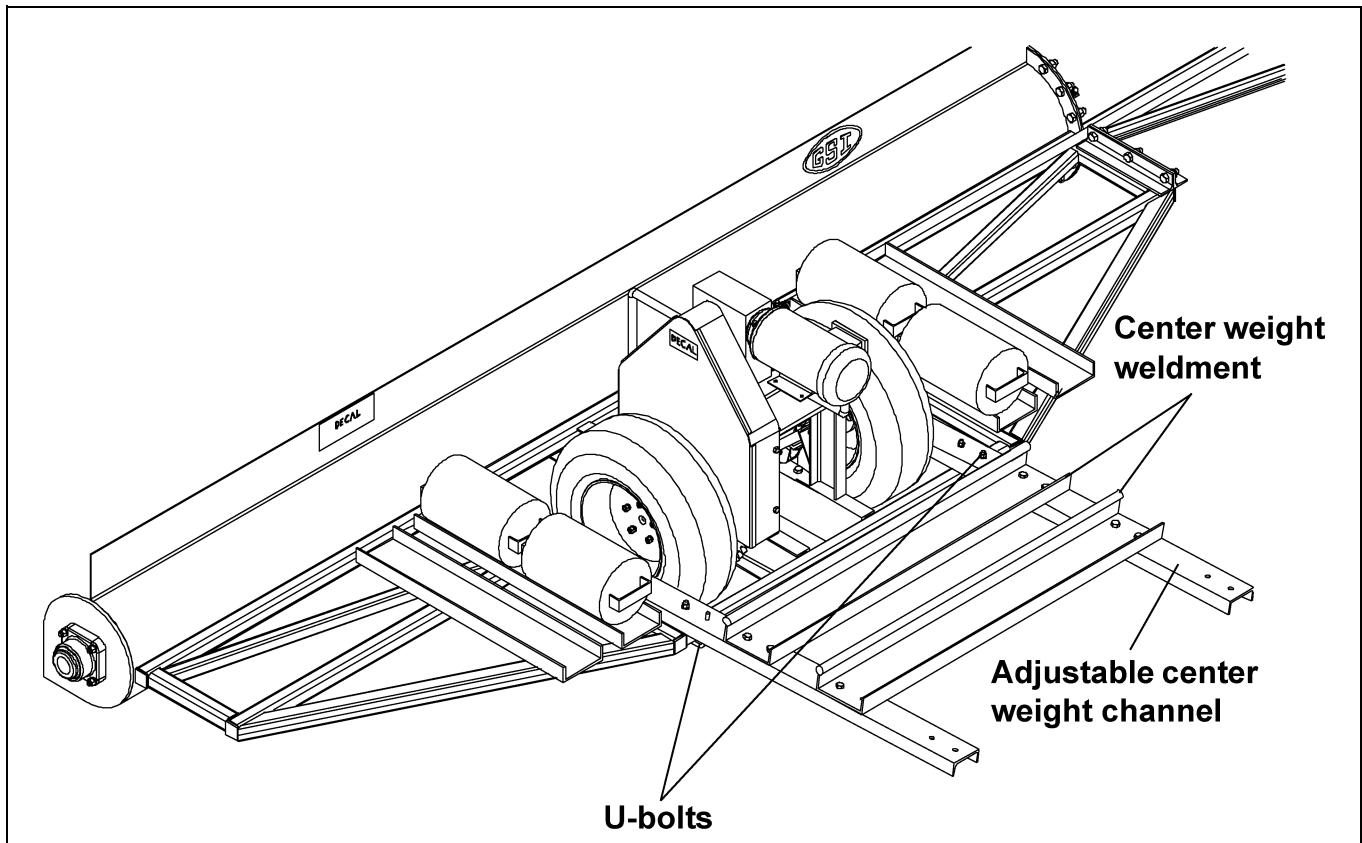

Figure 5T

- C. Place assembly on top of the back tail section, around the tires. The end of the adjustable center weight should be placed under the tail frame. (See Figure 5U.)

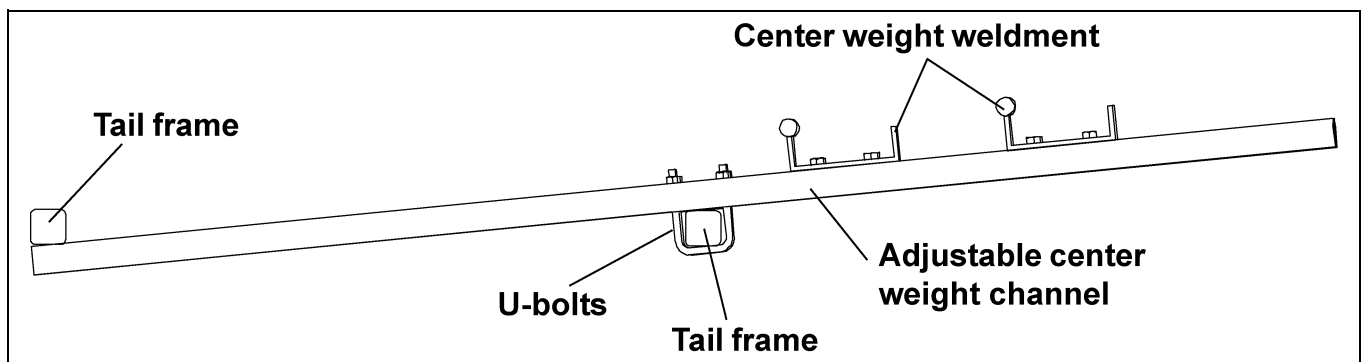

Figure 5U

- D. Fasten assembly to tail section using two (2) 3/8" x 2-7/16" U-bolts, four (4) 3/8" lock washers and four (4) 3/8" hex nuts.

5. Assembly

Motor Jack and Base Assembly

- A. Attach the Motor Mount Base Assembly to the Head Section using four (4) 3/4" x 2" bolts, lock washers and hex nuts. (See Figure 5V.)
- B. Attach the Motor Jack Assembly to the Motor Mount Base Assembly using four (4) 1/2"-13 x 1-1/2" bolts, 1/2" flat washers and 1/2" hex nuts.

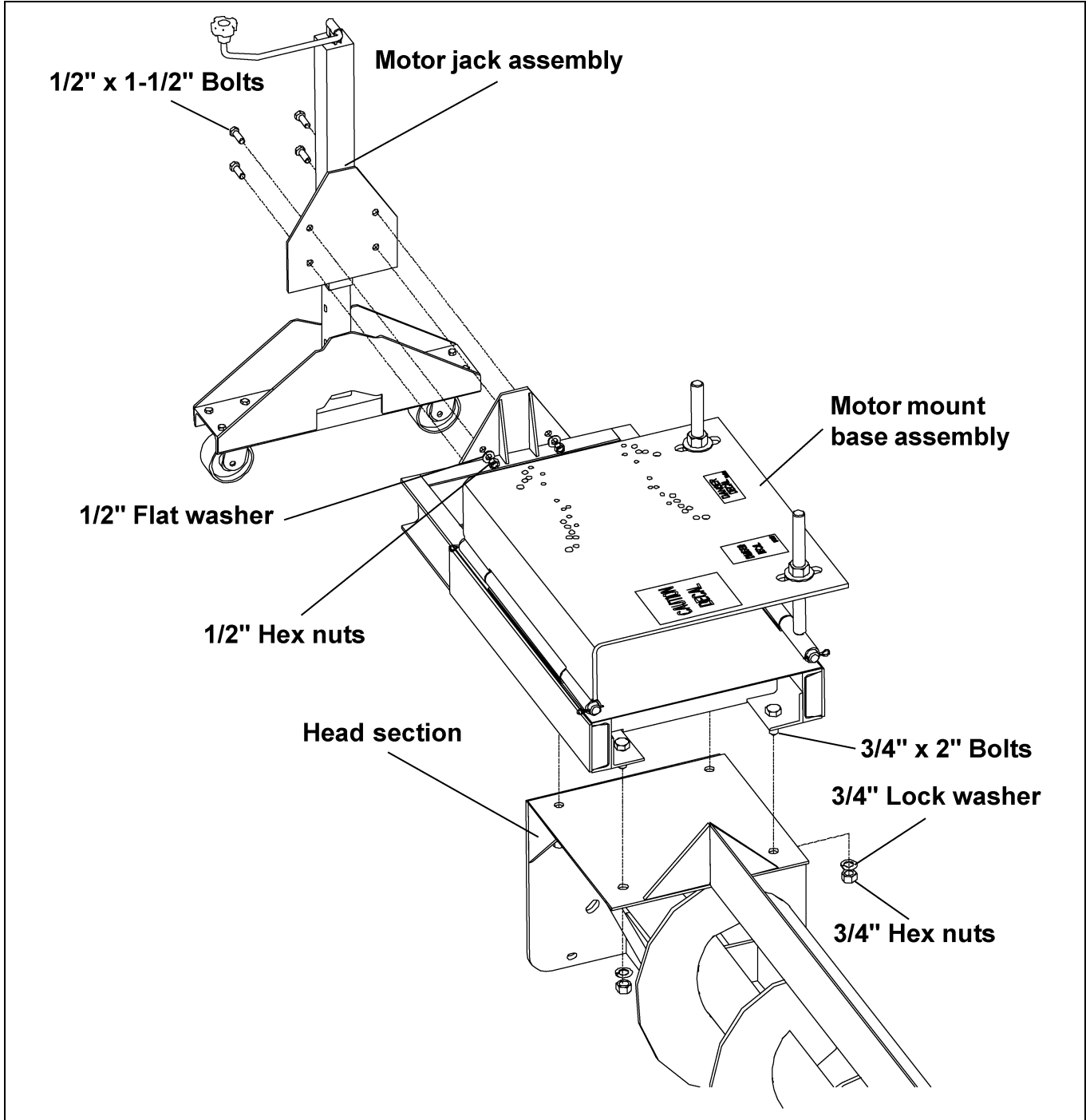

Figure 5V

Motor Installation

- A. Level the Top Plate Assembly by adjusting the 1" nuts and washers on the adjustment rods.
(See Figure 5W.)
- B. Line up the end face of the shafts as closely as possible before bolting motor to mounting plate.
(See Figure 5W-A.)

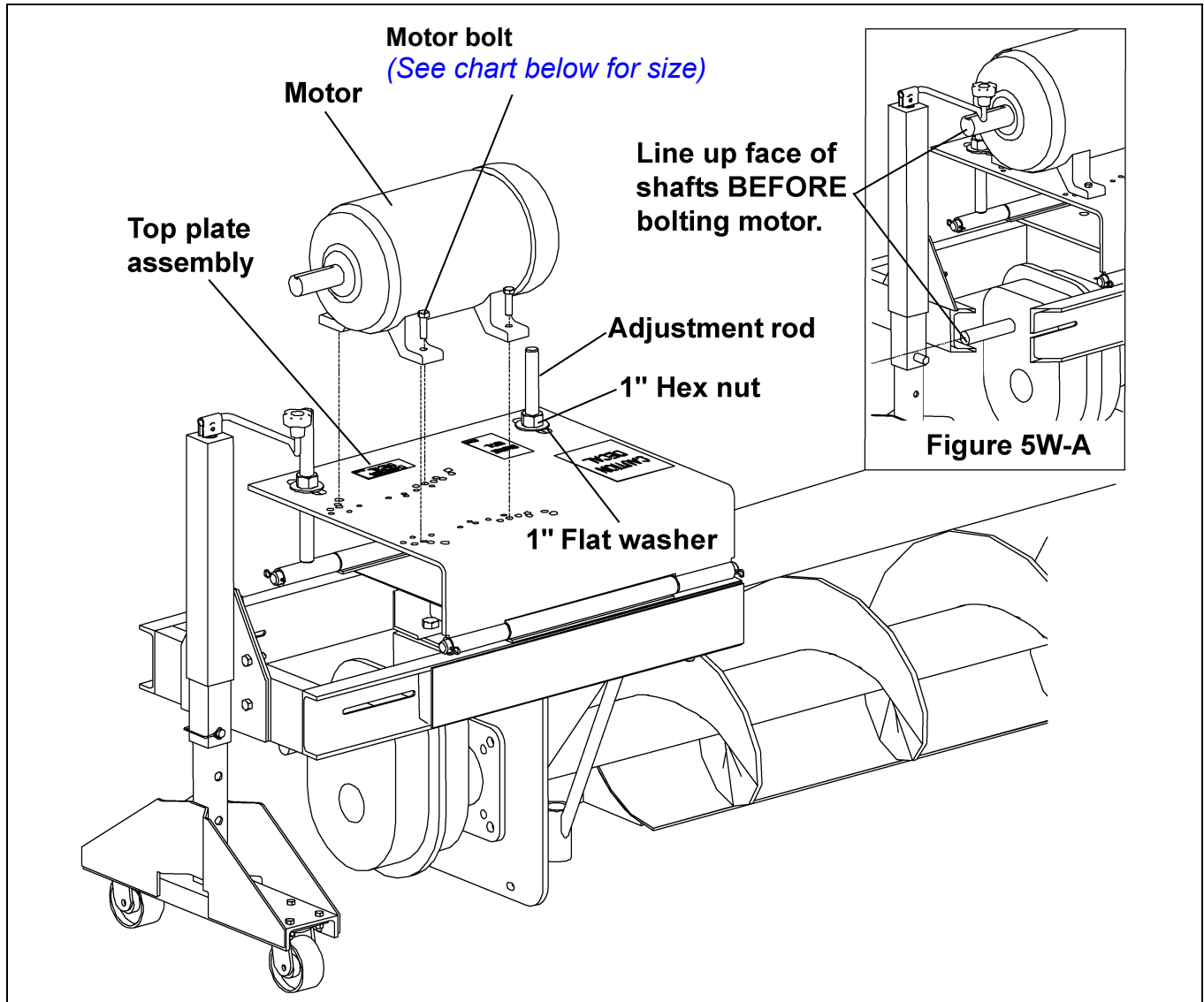

Figure 5W

- C. Fasten the motor to the motor mount using hex bolts, lock washers and hex nuts. (See *Motor Bolt Chart for bolt sizes.*)

Motor Bolt Chart		
Motor Size	Hex Bolt Size	Qty
213T	3/8"-16 x 1-1/4"	4
215T	3/8"-16 x 1-1/4"	4
254T	1/2"-13 x 1-3/4"	4
256T	1/2"-13 x 1-3/4"	4
284T	1/2"-13 x 1-3/4"	4
286T	1/2"-13 x 1-3/4"	4

Sheave Installation



To ensure that the drive is not unexpectedly started, turn OFF and lock out the power source before proceeding. Failure to observe these precautions could result in bodily injury.



Wedging forces in the bushing saw slot, such as that exerted by a narrow edged regular screw driver, may damage or break the bushing. This damage would not be covered under the GSI warranty.

NOTE: Owners and installers of 7000 bushel per hour Series II Sweeps using 230/460/575 Volt, 60 Hertz power should note that the belt drive for a 7000 bushel per hour sweep uses a special "Speed Up" style belt and sheave arrangement. The drive sheave is larger than the driven sheave. In almost all cases the drive sheave is a 7.15" outside diameter (6.8" P.D.) with the driven sheave a 6.3" outside diameter (6" P.D.)

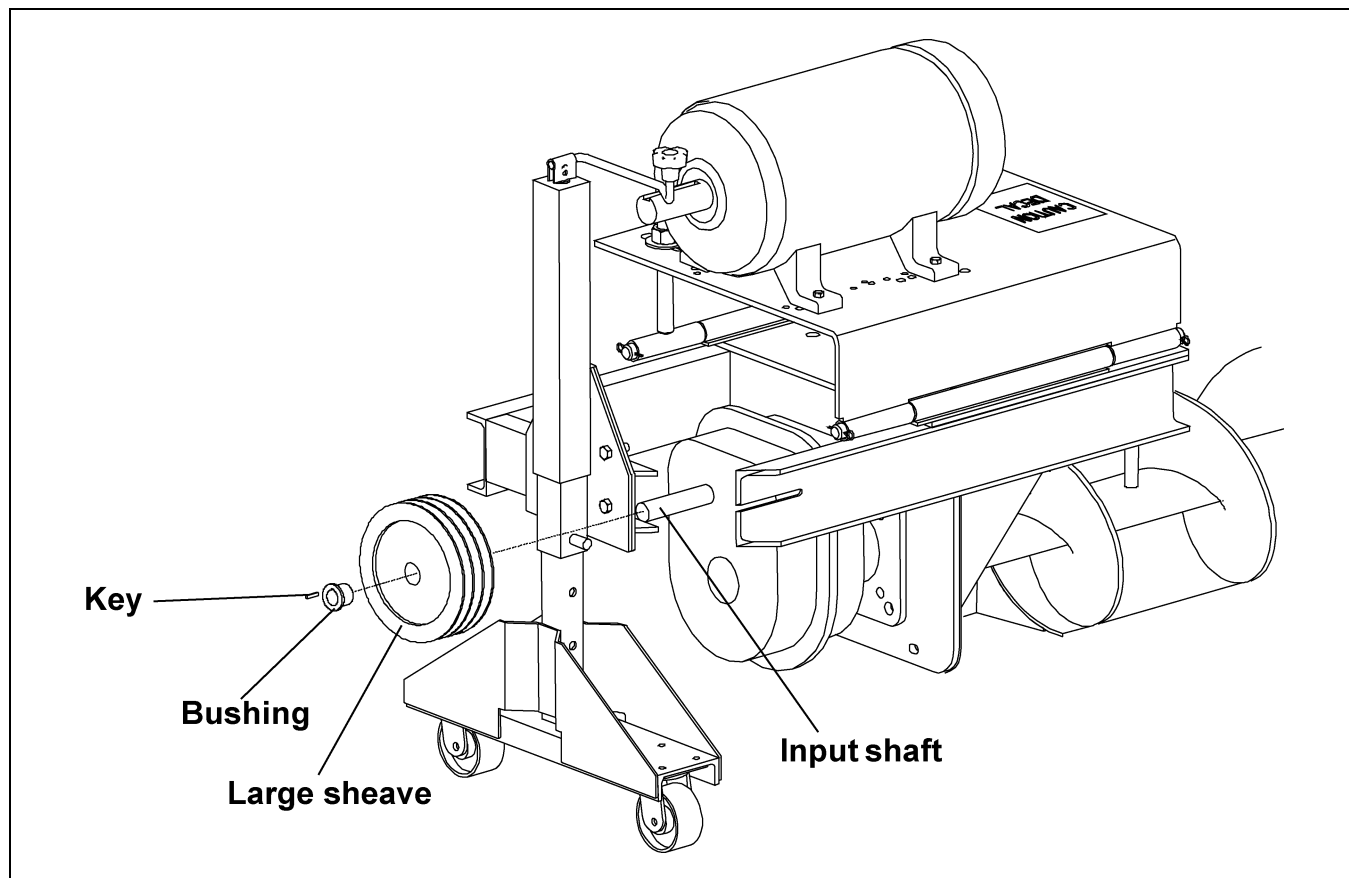

Figure 5X

- A. Loosely bolt the bushing and large sheave together with the screws provided with the bushing.
- B. Slide the bushing and large sheave onto the auger gear reducer input shaft with a key.
(See Figure 5X.)
- C. Loosely bolt the bushing and small sheave together with the screws provided with the bushing.

D. Slide the bushing and small sheave onto the motor shaft with a key. (See Figure 5Y.)

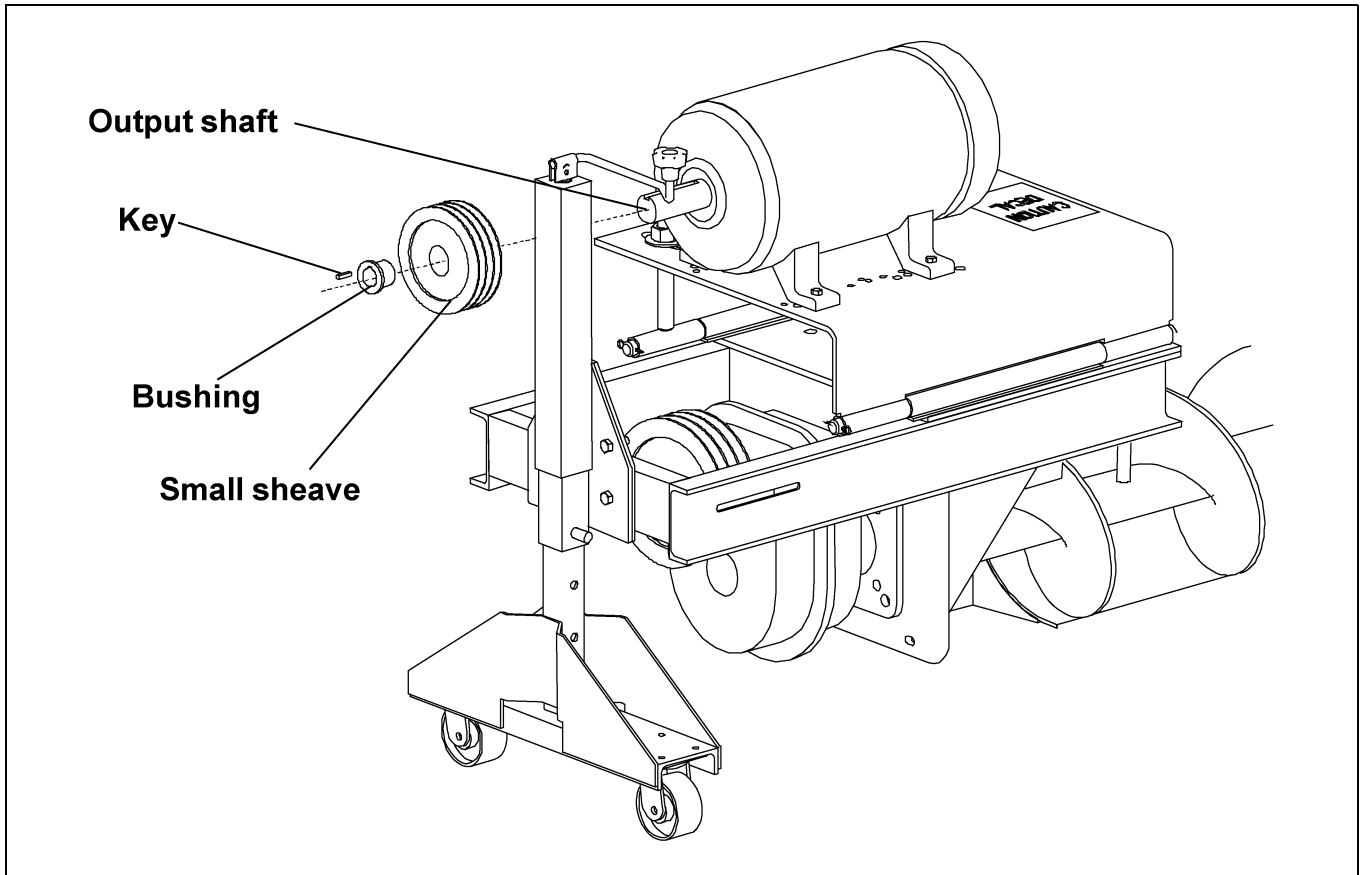

Figure 5Y

E. Align the sheaves with a straight edge to assure proper alignment and tighten the screws on the bushings. (See Figure 5Y.)

F. Carefully install the belts onto the large and small sheaves. (See Figure 5Z on Page 44.)

NOTE: Adjust the hex nuts on the motor mount adjustment rod to attain correct belt tension while making sure the motor mount is level on both rods. The motor mount must be parallel to the auger screw to allow for proper sheave alignment.

5. Assembly

G. Loosely bolt the bottom belt guard to the motor mount using four (4) 3/8"-16 x 1" hex bolts, flat washers and lock washers. (See Figure 5Z.)

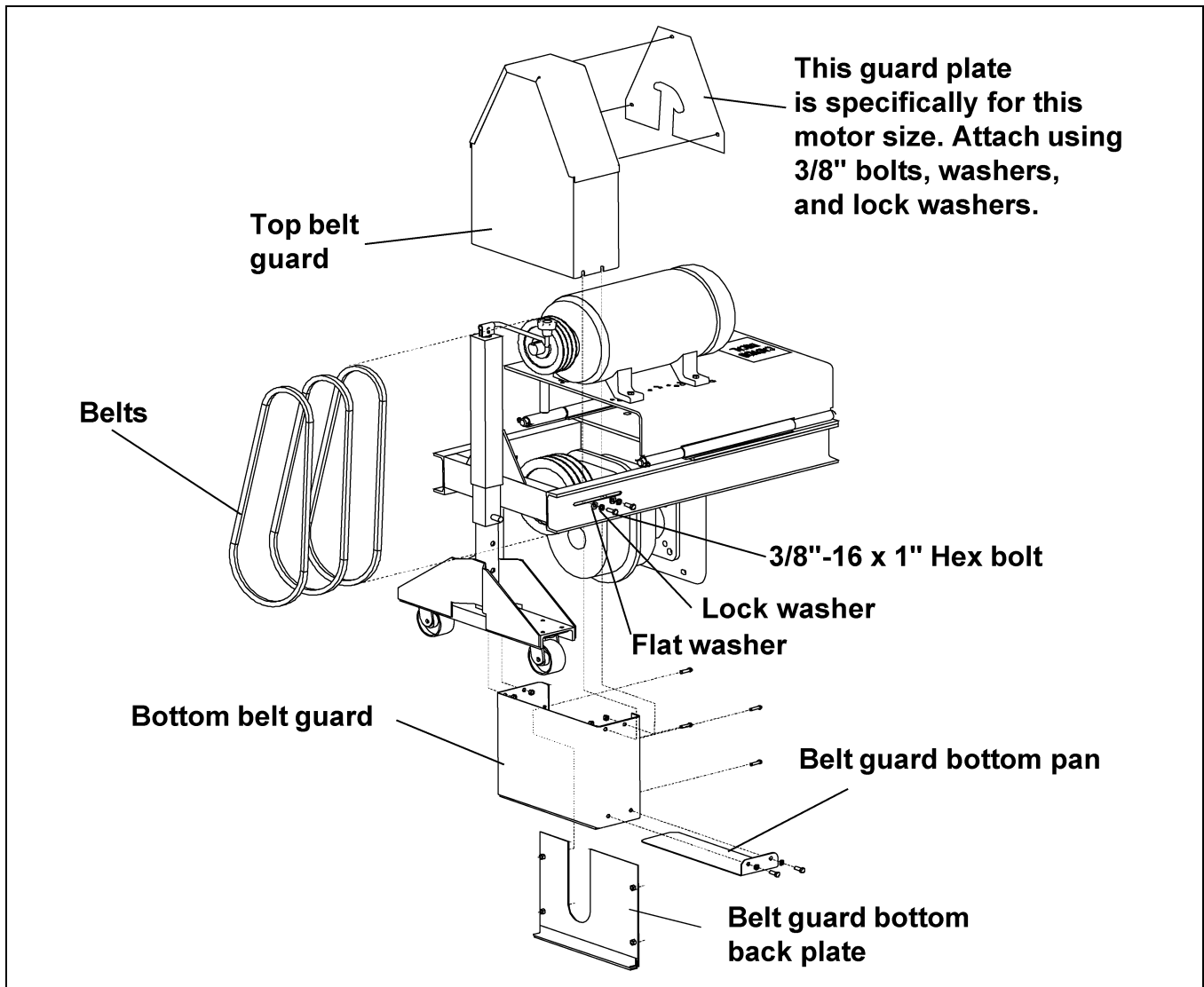

Figure 5Z

H. Slide the top belt guard over the bottom belt guard as shown in See Figure 5Z and tighten bolts.

I. Install belt guard bottom back plate.

J. Slide belt guard bottom pan and bolt into place.

Electrical Assembly



All electrical wiring and service work must be performed by a qualified electrician and must meet all State and Local Electrical Codes.

NOTE: See chart on Page 45 for the correct size of conduit with the corresponding sweep size.

A. Place the 3/4" rigid conduits in order starting with the head section and working towards the tail or extension section.

B. Connect the rigid conduit together using one 3/4" conduit coupling between each piece of conduit. (See Figure 5AA.)

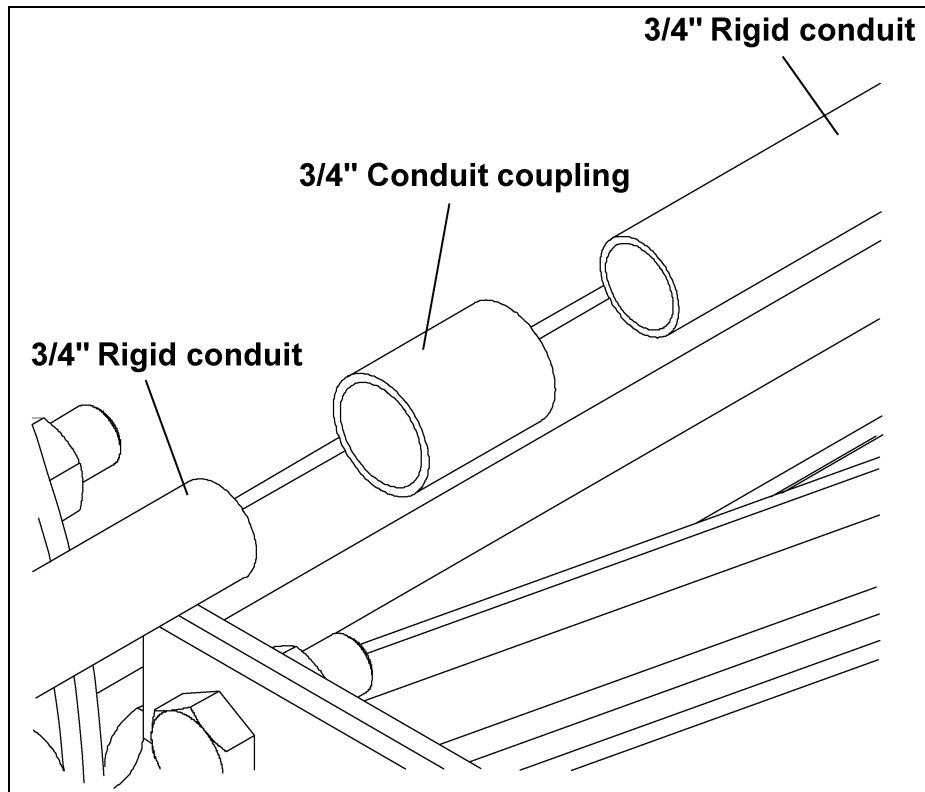

Figure 5AA

Sweep Section Conduit Sizes

Bin Diameter	10' Conduit Pieces	Other Pieces	Bin Diameter	10' Conduit Pieces	Other Pieces
36'	N/A	1 @ 9'	72'	2	1 @ 7'
37'	1	N/A	75'	2	1 @ 8'
39'-40'	1	1 @ 1'	78'	3	N/A
42'	1	1 @ 2'	80'-81'	3	1 @ 1'
43'-45'	1	1 @ 3'	84'	3	1 @ 3'
48'-49'	1	1 @ 5'	87'	3	1 @ 4'
51'	1	1 @ 6'	88'	3	1 @ 5'
54'-55'	1	1 @ 8'	90'-91'	3	1 @ 6'
57'	1	1 @ 9'	92'	3	1 @ 7'
59'	2	N/A	95'	3	1 @ 8'
60'	2	1 @ 1'	98'	4	N/A
62'-63'	2	1 @ 2'	105'	3	1 @ 9'
66'	2	1 @ 4'	113'-120'	4	N/A
68'-69'	2	1 @ 5'			

C. Connect the 3/4" x 48" liquid-tight flex conduit to the drive end of the 3/4" rigid conduit using one 3/4" conduit coupling and one 3/4" liquid-tight flex conduit coupling. (See Figure 5AB on Page 46.)

1. Thread a 3/4" conduit coupling onto the 3/4" rigid conduit. (See Figure 5AB on Page 46.)
2. Thread a 3/4" flex conduit coupling body onto the 3/4" conduit coupling. (See Figure 5AB on Page 46.)
3. Slide a 3/4" flex conduit coupling cap onto the 3/4" flex conduit followed by a plastic ring. (See Figure 5AB on Page 46.)

5. Assembly

4. Thread a steel ring into the 3/4" flex conduit. (See Figure 5AB.)
5. Thread the 3/4" flex conduit coupling cap onto the 3/4" flex conduit coupling body. (See Figure 5AB.)

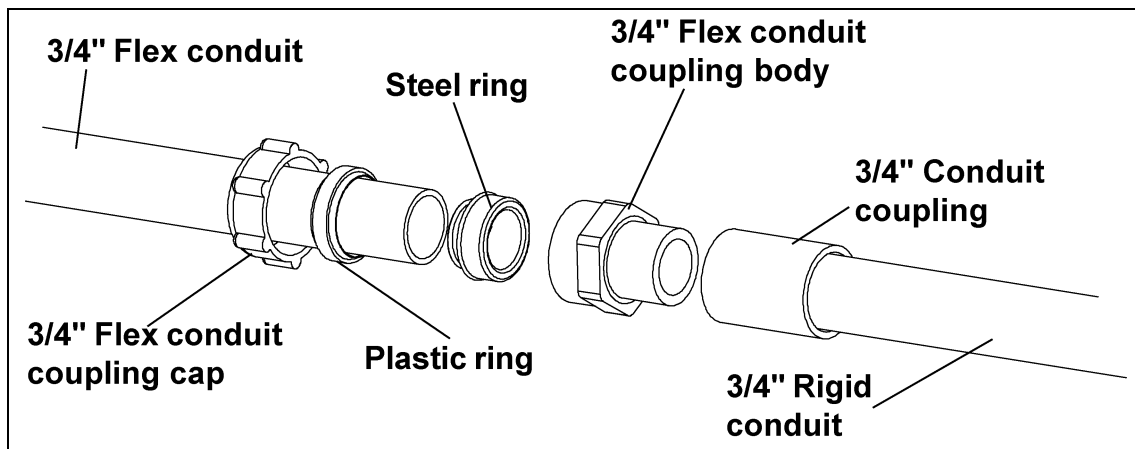

Figure 5AB

- D. Attach the 3/4" x 12" liquid-tight flex conduit to the other end of the rigid conduit using one 3/4" conduit coupling and one 3/4" liquid-tight flex conduit coupling. (See Figure 5AC.)
- E. Connect the two (2) junction boxes together using the 1" x 4-3/4" conduit nipple. (See Figure 5AC.)
- F. Connect the 3/4" x 12" liquid-tight flex conduit to the left junction box using one 3/4" liquid-tight flex conduit coupling and one 1" to 3/4" reducer bushing. (See Figure 5AC.)
- G. Attach the 3/4" x 40" liquid-tight flex conduit to the right junction box using one 3/4" liquid-tight flex conduit coupling and one 1" to 3/4" reducer bushing. (See Figure 5AC.)

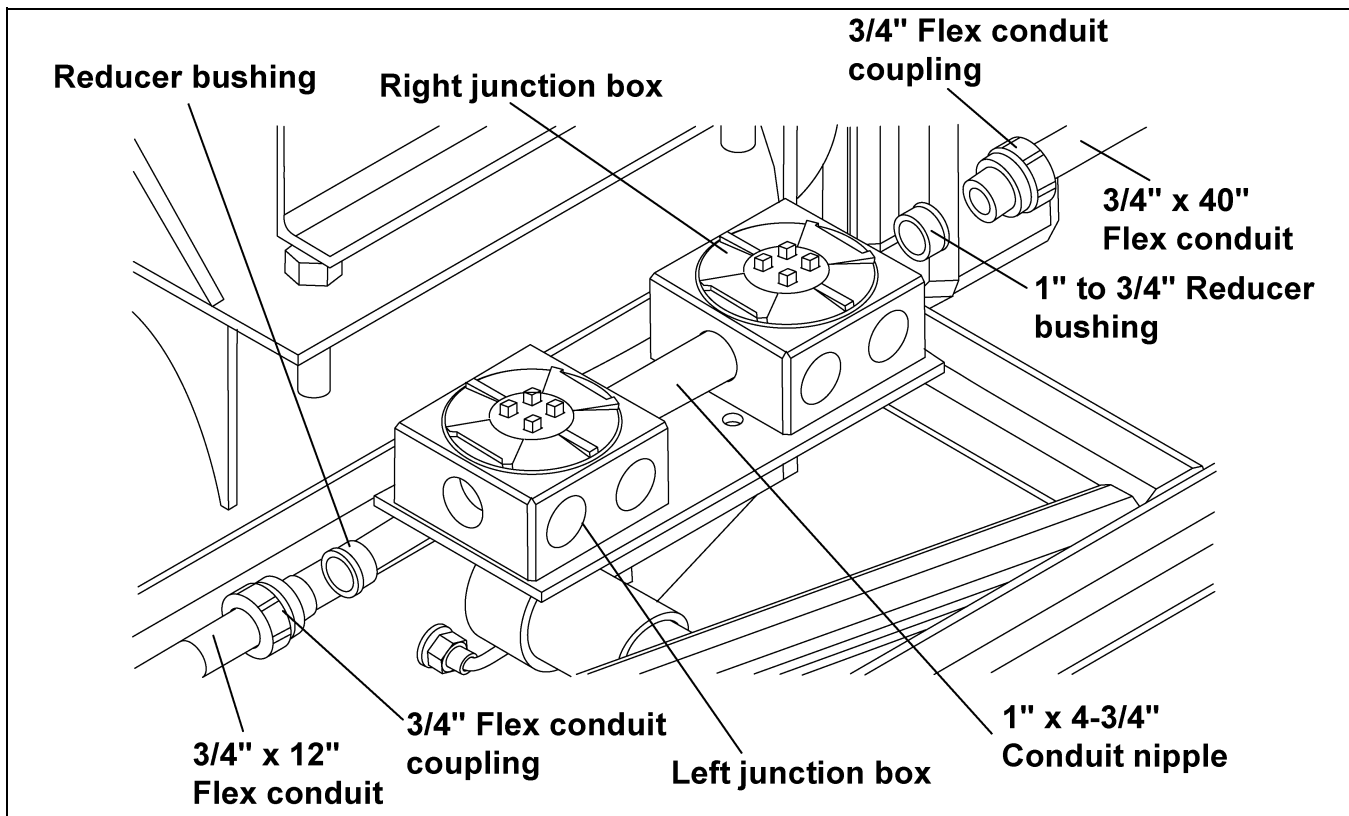

Figure 5AC

- H. Feed each of the six (6) 14 AWG stranded wires through the 3/4" rigid conduit assembly and cut them off, leaving six inches (6") at both the left junction box and drive motor.
- I. Feed each of the six (6) 10 AWG stranded wires cord through the 3/4" x 40" liquid tight flex conduit and cut four (4) of them off, leaving six inches (6") at both the right junction box and auger motor. Cut the 10 AWG blue and yellow wires longer so they can be connected to the 14 AWG blue and yellow wires in the left junction box.
- J. Place the 3/4" rigid conduit assembly onto the back frame of the sweep between the connecting angle and connecting flange.

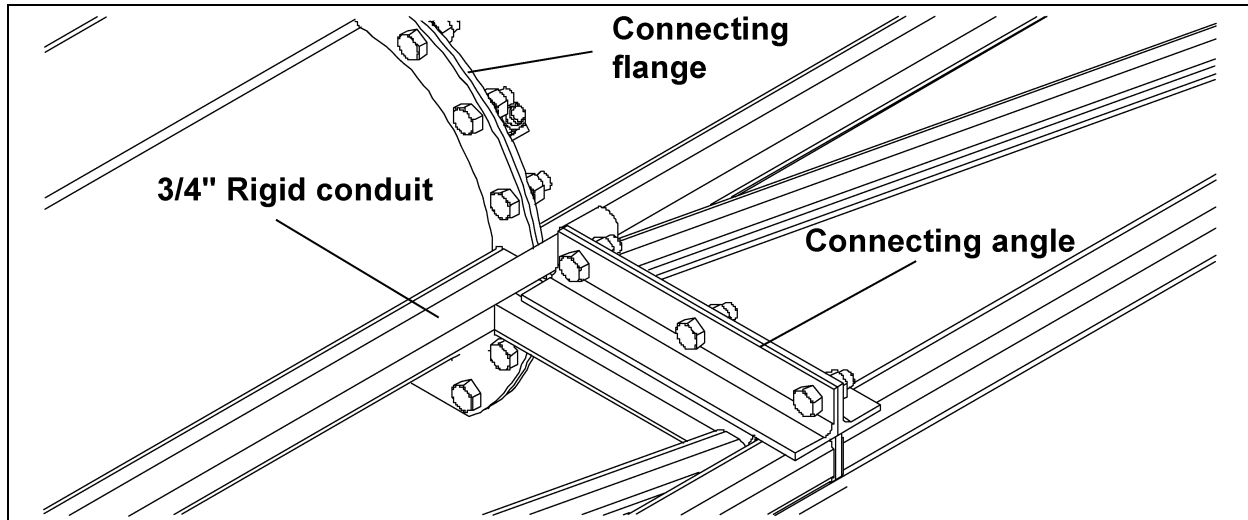

Figure 5AD

- K. Fasten the junction boxes to the mounting plate using two (2) 3/8"-16 x 1-3/8" U-bolts, four (4) lock washers and hex nuts.

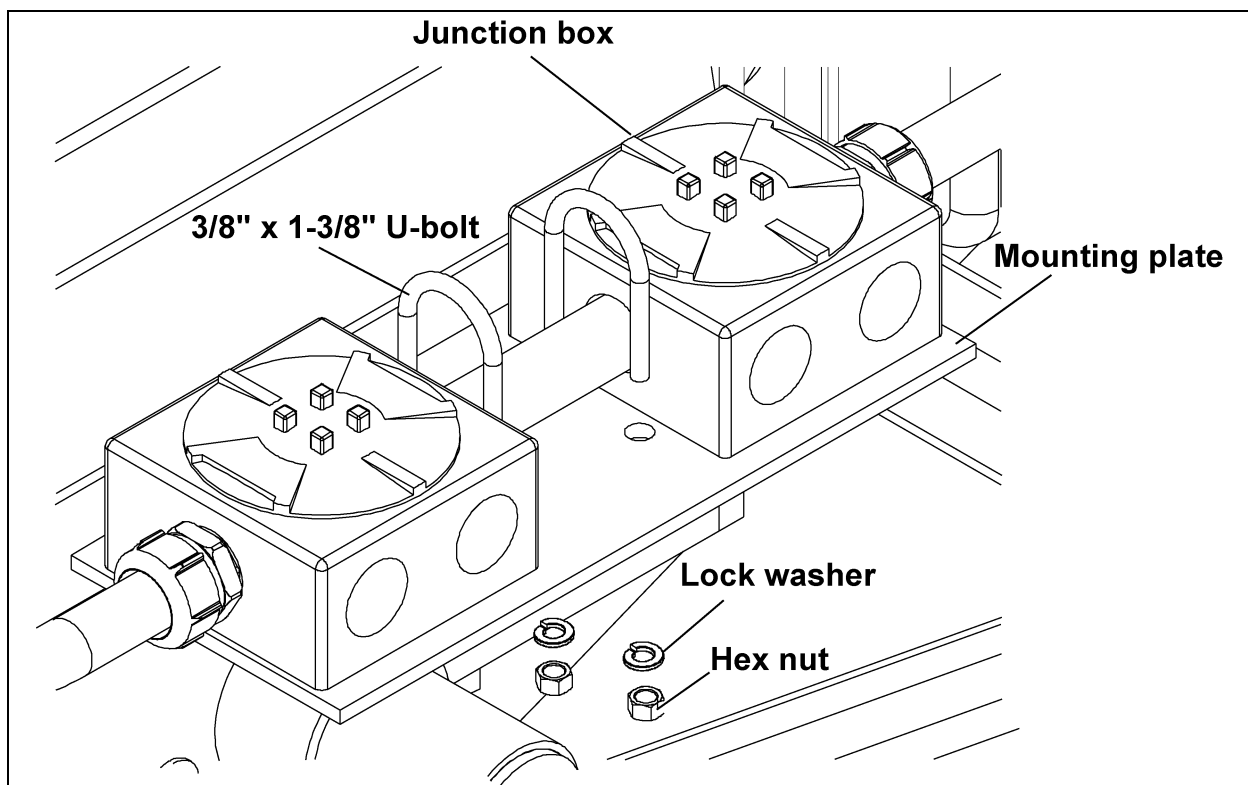

Figure 5AE

5. Assembly

- L. Attach the 3/4" rigid conduit assembly to the sweep using the 5/16"-18 x 3/4" studs welded to the sweep using 1" conduit clamps, lock washers and hex nuts.
- M. Run the 14 AWG stranded wires into the drive motor and fasten the 3/4" x 48" liquid-tight flex conduit to the motor using one 3/4" liquid-tight flex conduit coupling. Some motors may require a reducer bushing not supplied with the sweep. Connect the leads as required.

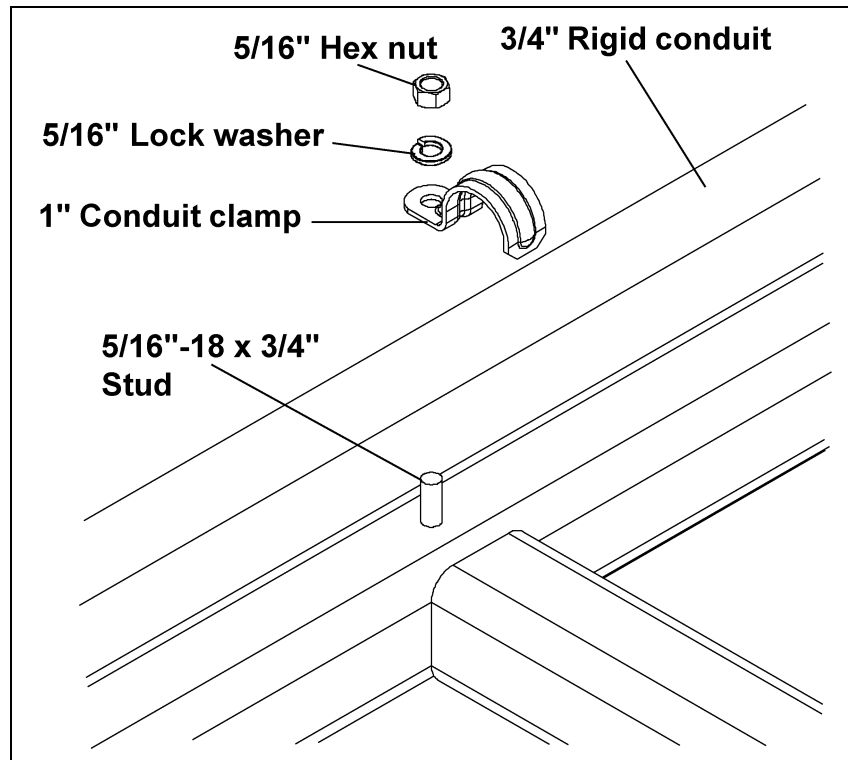

Figure 5AF

- N. Run the 10 AWG stranded wires into the auger motor and fasten the 3/4" x 40" liquid-tight flex conduit to the motor using one 3/4" liquid-tight flex conduit coupling. Some motors may require a reducer bushing not supplied with the sweep. Connect the leads as required.

NOTE: If you are using the pivot kit, skip to [Page 52](#) and refer to "Step A on Page 52".

- O. **Tractor Drive:** Slide a 5/8" to 3/4" cord connector six inches (6") onto one end of the 14 AWG/4 wire cords and fasten it to the junction box using one 1" to 3/4" reducer bushings. Connect the leads as required.

Sweep Drive all 12" and 16" under 105 Model: Slide a 5/8" to 3/4" cord connector six inches (6") onto one end of the 10 AWG/4 wire cords and fasten it to the junction box using one 1" to 3/4" reducer bushings. Connect the leads as required.

Sweep Drive all 16" 105 Model and over: Slide a 5/8" to 3/4" cord connector six inches (6") onto one end of the 8 AWG/4 wire cords and fasten it to the junction box using one 1" to 3/4" reducer bushings. Connect the leads as required.

- P. Slide a 1/2" to 5/8" cord connector six inches (6") onto the end of the 14 AWG/3 wire cord and fasten it to the junction box using one 1" to 3/4" reducer bushings. Connect the leads as required.
- Q. Use the plugs provided with the junction boxes to close the holes not being used.

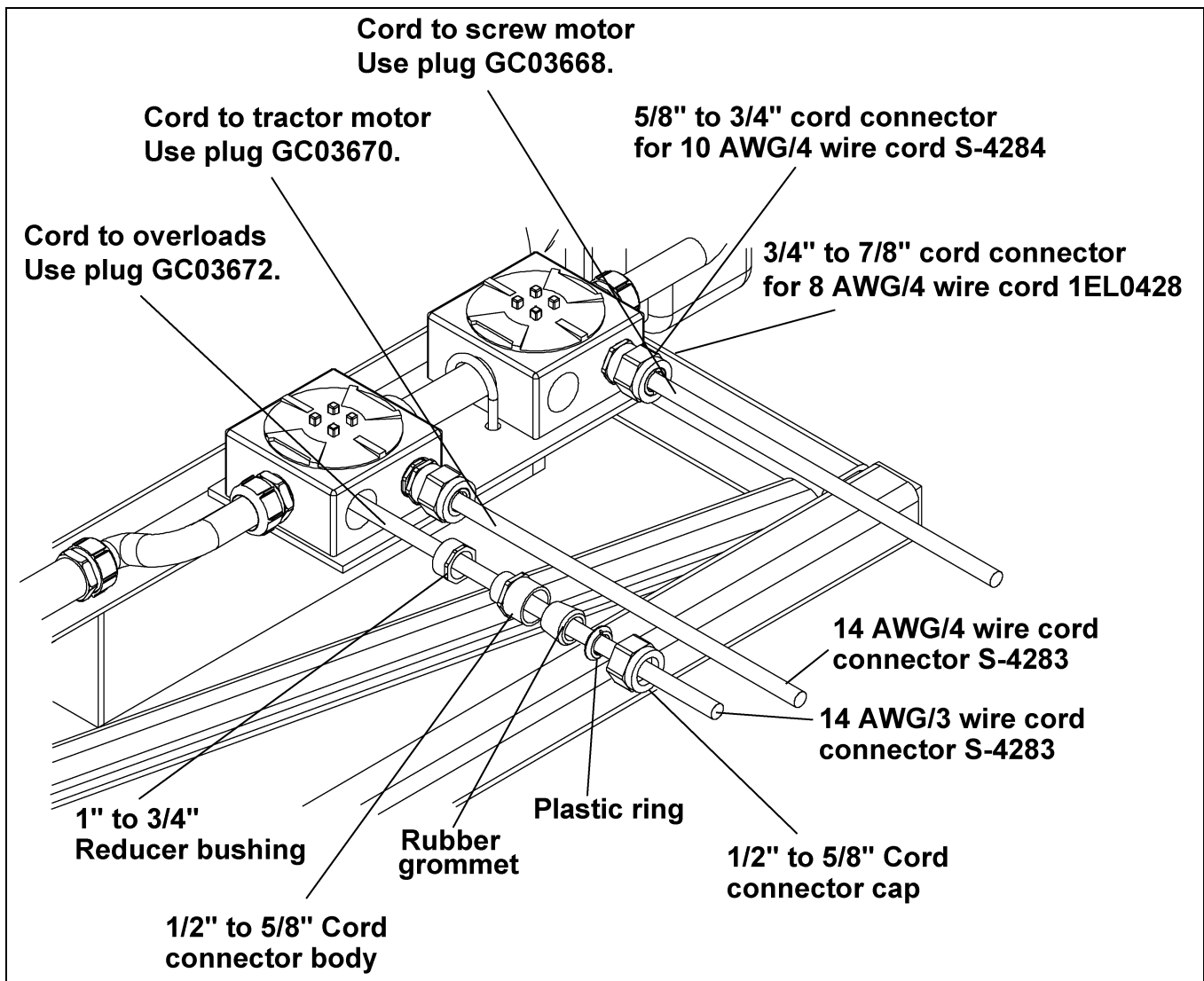

Figure 5AG

- R. Assemble the cord plugs to the other end of each cord. The 14 AWG/4 wire cord requires the (GC03670) plug. The 10 AWG/4 and 8 AWG/4 wire cord requires the (GC03668) plug. The 14 AWG/3 wire cord requires the (GC03672) plug.



The plugs are different for each cord and MUST be assembled correctly. This prevents cords from being plugged into the control panel incorrectly.

- S. Mount the control panel outside the bin near the door.



The control panel MUST be mounted OUTSIDE the bin, near the door. The foot switch has to be plugged into the control panel and depressed before the sweep is operational. It has a 10' cord so the sweep can only be monitored from OUTSIDE the bin.

5. Assembly

Jack Support Assembly

NOTE: Be sure to use the spanner bushings, supplied with the caster wheels, between the caster and the caster plate on each side.

All Current Production and Old Style 12" Jack Support (See Figure 5AH and Figure 5AI on Page 51.)

- A. Attach one caster wheel to the jack caster assembly using one 3/4" x 5-1/2" hex bolt, lock washer and hex nut.
- B. Locate the 2" x 2" x 12" tube to the right of each connecting angle and fasten the jack mount assembly to the sweep frame using one jack mount plate, four (4) 1/2"-13 x 3-3/4" hex bolts, lock washers and hex nuts.
- C. Attach the jack caster assembly to the jack assembly using one pin.
- D. Bolt the jack assembly to the jack mount assembly using four (4) 1/2"-13 x 2" hex bolts, lock washers and hex nuts.

All Old Style 16" Jack Support (See Figure 5AH and Figure 5AI on Page 51.)

- A. Attach one caster wheel to the jack caster assembly using one 3/4" x 5-1/2" hex bolt, lock washer and hex nut.
- B. Locate the 2" x 2" x 12" tube to the right of each connecting angle and fasten the jack mount assembly to the sweep frame using one jack mount plate, four (4) 1/2"-13 x 3-3/4" hex bolts, lock washers and hex nuts.

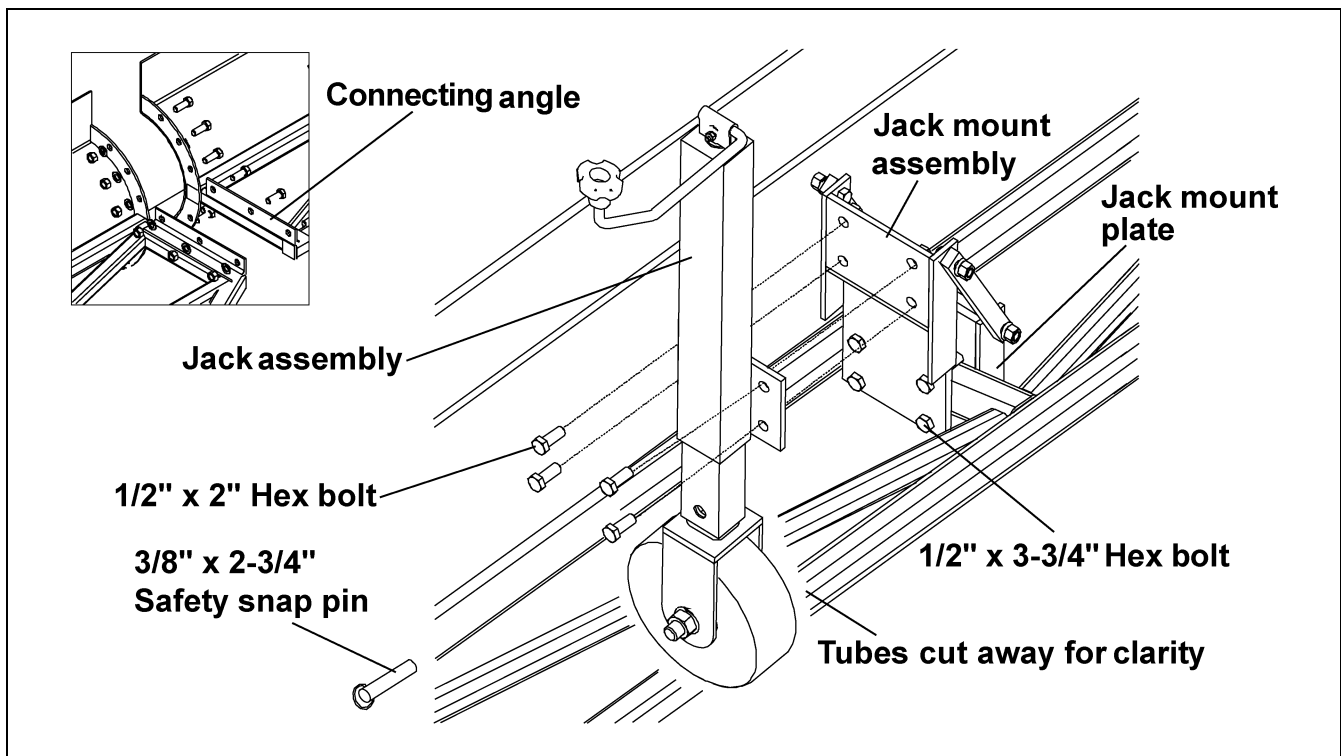

Figure 5AH Current Production Sweep Shown

- C. Attach 16" Jack Caster Assembly to the swivel caster wheel using four (4) 1/2" x 1-1/2" HHCS bolts, lock washers and hex nuts.

D. Attach the jack caster assembly to the jack assembly using one pin.

E. Bolt the jack assembly to the jack mount assembly using four (4) 1/2"-13 x 2" hex bolts, lock washers and hex nuts.

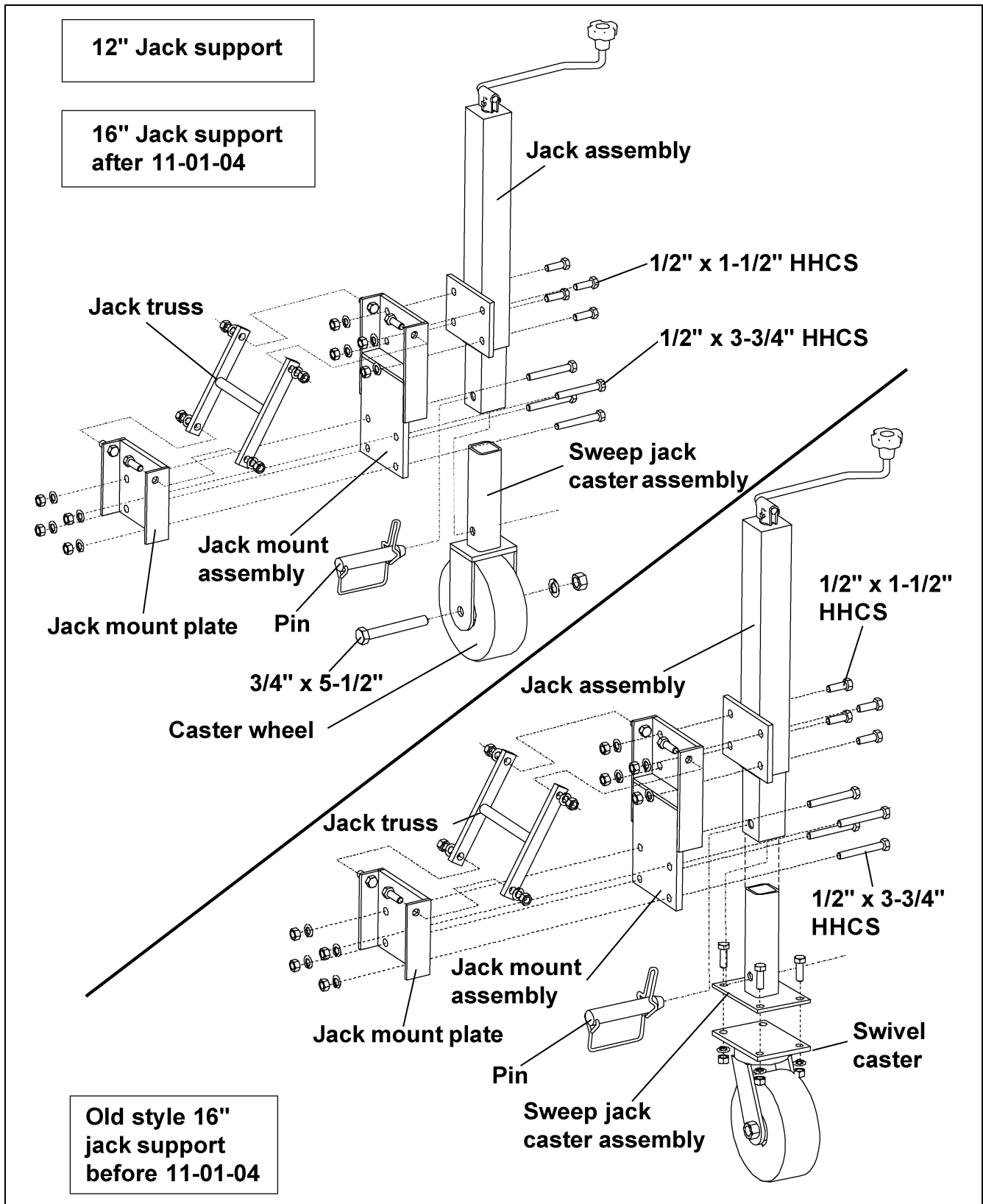

Figure 5AI

5. Assembly

Center Pivot Installation

NOTE: If you are only running the cords across the floor, you may skip [Step A](#) and go to [Step B on Page 55](#).

A. Center Pivot with Pivot Kit

1. Use the pivot assembly supplied with the sweep pivot kit and cut it to fit, if needed.



The center pipe of the pivot assembly *MUST* be in the center of the bin. If it is not, the sweep could hit the bin wall.

2. Feed the multi-conductor cord through the hole in the back of the sweep head section leaving five feet (5') of cord outside the hole. ([See Figure 5AJ.](#))

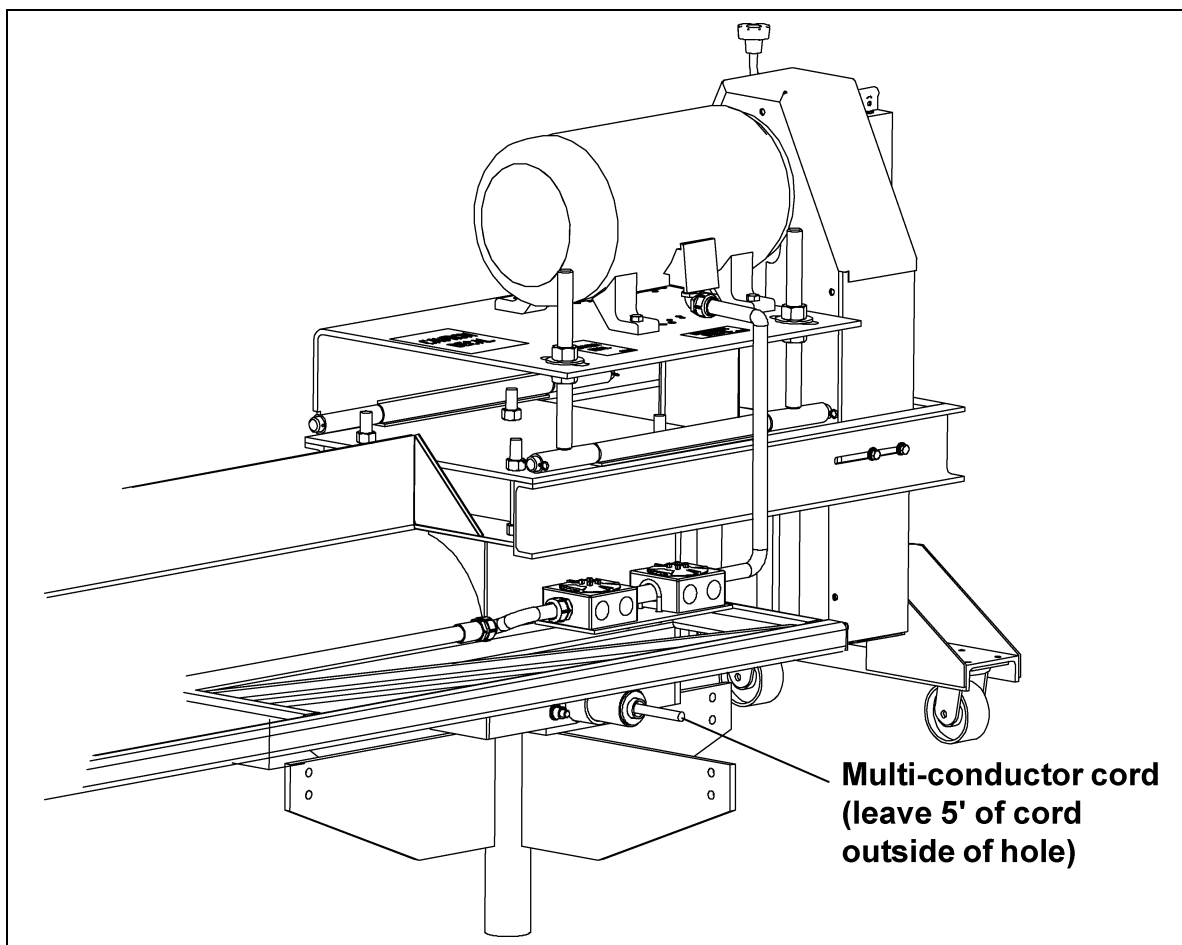

Figure 5AJ

3. Feed the power cord through the pivot tube. ([See Figure 5AK on Page 53.](#))
4. Align the hole in the backshield with the pivot tube and push the sweep onto the pivot tube. ([See Figure 5AK on Page 53.](#))
5. Connect the pivot plate to the backshield using two (2) 1/2"-13 x 1-3/4" hex bolts, flat washers, lock washers and hex nuts. ([See Figure 5AK on Page 53.](#))
6. Fasten the pivot rod to the backshield and pivot plate using two (2) 1/2"-13 x 2" hex bolts, lock washers and hex nuts. ([See Figure 5AK on Page 53.](#))

5. Assembly

8. Connect the 1" x 48" liquid-tight flex conduit to the pivot tube using one 1" conduit coupling and one 1" liquid-tight flex conduit coupling. (See Figure 5AL.)
9. Connect the 1" x 48" liquid-tight flex conduit to one of the junction boxes using one 1" liquid-tight flex conduit coupling. Connect the leads as required. (See Figure 5AL.)
10. The customer is to provide proper power cord protection between the pivot assembly and the sump transition. (See Figure 5AL.)

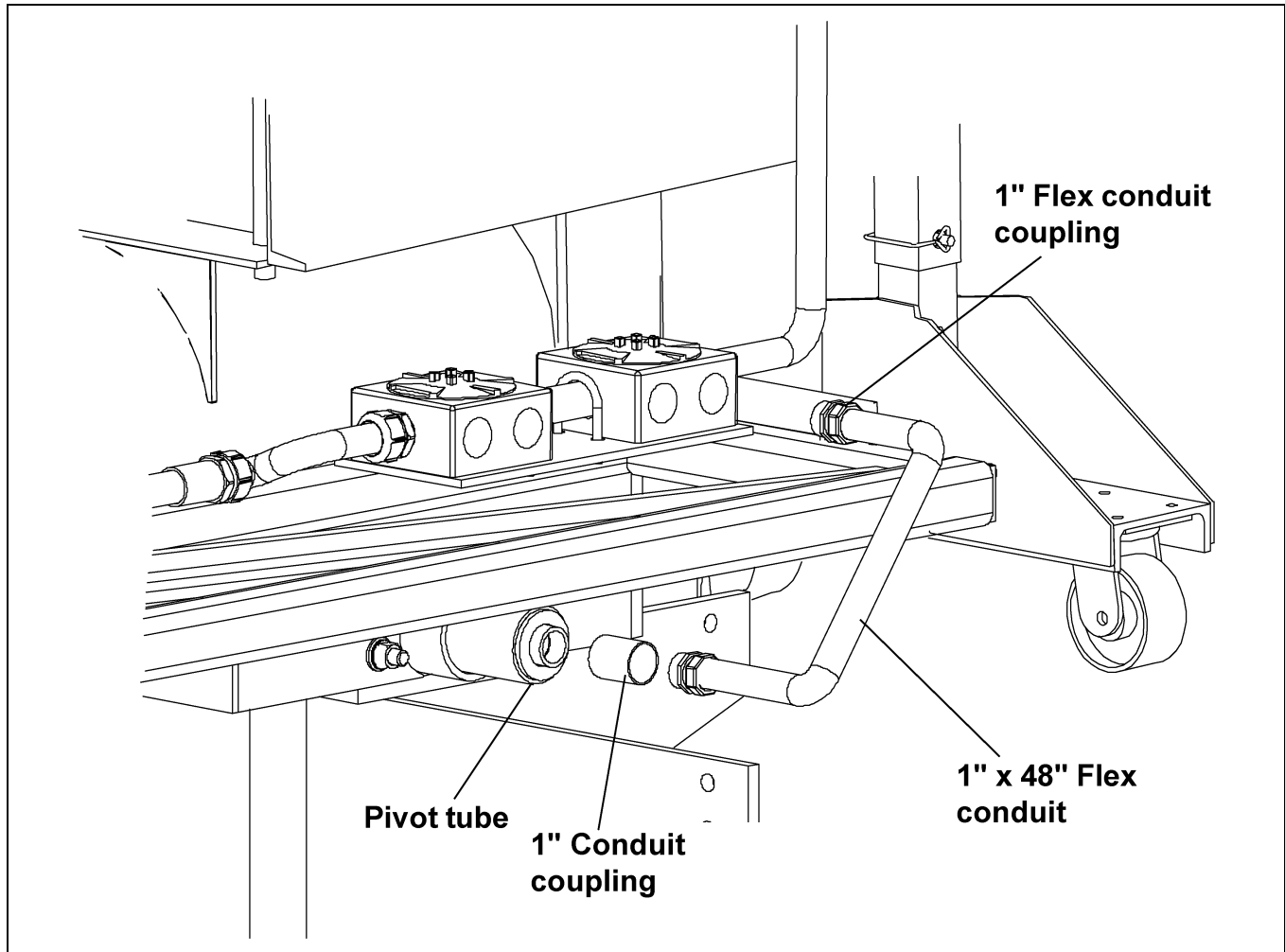

Figure 5AL

11. The multi-conductor power cord can be connected with the 14 AWG/3 wire, 14 AWG/4 wire and 10 AWG/4 wire cords in an explosion proof junction box.
12. Use the plugs provided with the junction box to close the holes not being used.
13. If applicable, assemble the cord plugs to the other end of each of the cords. The 14 AWG/4 wire cord requires the (GC03670) plug. The 8 AWG/4 and the 10 AWG/4 wire cord requires the (GC03668) plug. The 14 AWG/3 wire cord requires the (GC03672) plug. Otherwise, hard wire the motor cords into the control panel.



The plugs are different for each cord and MUST be assembled correctly. This is done to prevent the cords from being plugged into the control panel incorrectly.

B. Center Pivot for Standard Sweep

NOTE: *The center pivot for a standard sweep must be supplied by the customer. The following are requirements for installation.*



The pivot pin *MUST* be in the center of the bin. If it is not, the sweep could hit the bin wall.

1. The cross braces must be 1/2" steel plate.
2. The pivot pin must be 1-1/2" diameter steel bar and extend approximately 4" above floor elevation.

Control Panel Setup

If the meter looks like this:

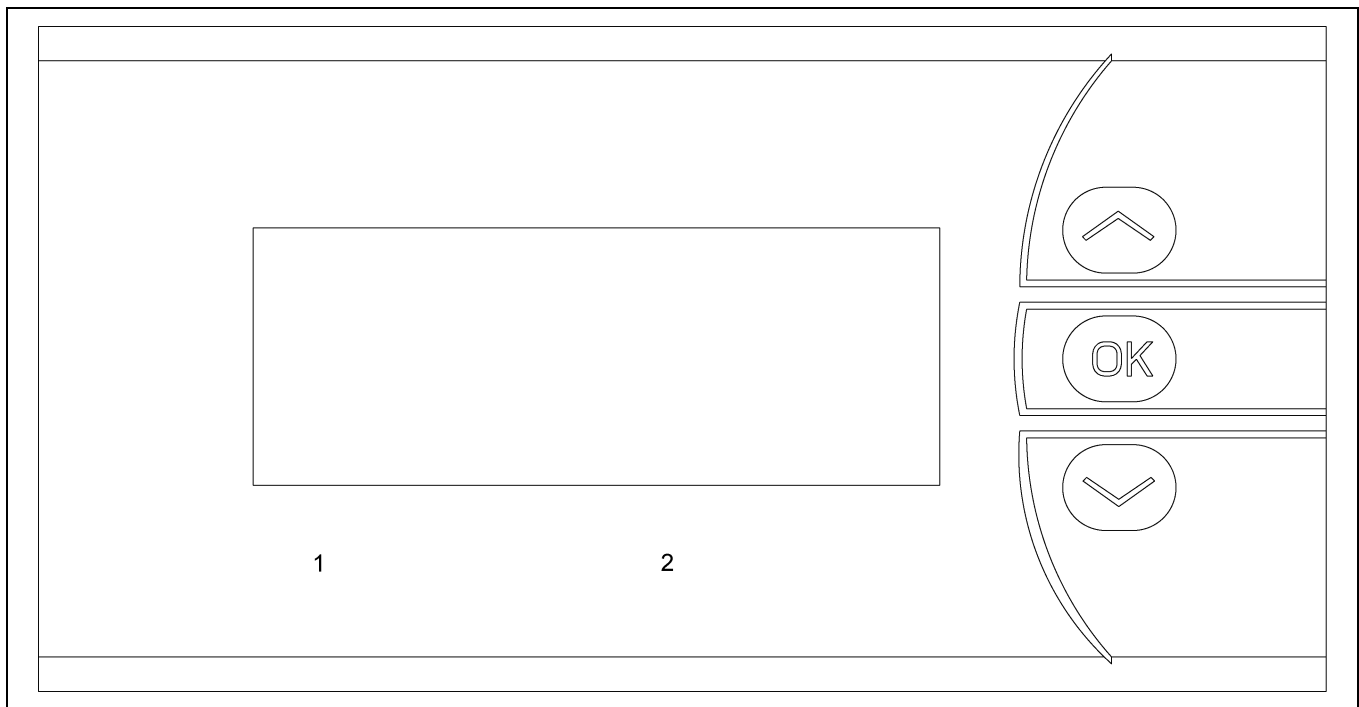

Figure 5AM

Follow these instructions:

The control panel is intended for hard wired connections for power in, auger drive motor wiring, tractor drive motor wiring and the thermal overload wiring for both the auger drive motor and the tractor drive motor.

If the system that this control panel is designed to have the cables for the auger drive motor and the tractor drive motor run inside the bin on the floor and exit through the bin door, a plug package is available to allow the panel to connect to the cords without hard wiring. This package is GC20117. This package is only standard in the center pin style sweep systems and not in the protected cord center sweep systems.

5. Assembly

Control Panel Calibration

Observe the tractor drive motor nameplate and the auger drive motor nameplate.

Record the full load amp (FLA) value for the specific voltage on each motor.

Auger drive motor full load amps: _____

Tractor drive motor full load amps: _____

Switch the disconnect switch on the panel to OFF (not ON).

Unlock and open the control panel.

Adjust the FLA dial screw on the tractor drive motor contactor (M1) and the auger drive motor contactor (M2) so that the indicator arrowhead is set slightly higher than the full load amp value listed on the nameplates.

Tractor drive motor contactor (M1) FLA adjustment dial: _____

Auger drive motor (M2) FLA adjustment dial value: _____

Close and lock the control panel.

Switch the disconnect switch on the panel to ON (not OFF).

Initial Display Setup

NOTE: *If no keys are activated for 2 minutes, the display returns to the default state without saving any configuration changes. At each value, after 5 seconds of inactivity, a description of the current state will scroll across the display.*

NOTE: *Pressing and hold OK will return to the previous menu or return to the default state without saving the changed values or parameters.*

Press OK on the display unit.

(IN) should be displayed on the unit.

Press \uparrow or \downarrow on the display unit until (CURR) is shown (not VOLT, POTM, or TEMP).

Press OK.

(RANG) should be displayed on the unit.

Press \uparrow or \downarrow on the display unit until 4-20 is shown (not 0-20).

Press OK.

(DEC.P) should be displayed on the unit.

Press \uparrow or \downarrow on the display unit until 11.11 is shown (not 1111, 111.1, 1.111 or .1111).

Press OK.

(DI.LO) should be displayed on the unit.

Press \uparrow or \downarrow on the display unit until 0 is shown.

Press OK.

(DI.HI) should be displayed on the unit.

The DI.HI value is 2x the value that the FLA dial on the auger drive motor (M2) that was set earlier.

2x FLA Dial: _____

Press \uparrow or \downarrow on the display unit until the correct value is shown.

Press OK repeatedly until "----" is displayed. This indicates the programming described above has been saved.

Make sure no individual is inside the bin.

Make sure the sweep will not contact any obstruction and cause damage.

Have an employee observe the sweep from outside the bin, through the open door.

The person observing the sweep is meant to have control over the safety foot switch.

Have another employee operate the control panel.

Switch the Run Mode switch so that Manual is selected (not Auto).

Switch the Manual Mode switch to idle (not reverse or forward).

Depress the pedal in the safety foot switch.

Press the Start button on the control panel.

NOTE: *If any damage is observed or there is abnormal operation of the sweep, shut it down immediately. There are three (3) ways to accomplish this. 1) Remove the pressure on the safety foot switch. 2) Press the Stop button on the control panel. 3) Press in on the Enable/Disable button so that it collapses appropriately. Switch the disconnect switch on the panel to OFF (not ON). Lock out the panel before entering the bin to service the sweep.*

Observe the no load amps (NLA) displayed on the meter on the front of the panel.

Auger drive motor no load amps: _____

The tractor motor operation (forward and stop) in automatic is dictated by the amp reading on the auger drive motor.

The tractor drive motor is meant to shut off (idle) when the Auger Drive Motor reaches 90% of the nameplate FLA.

90% of full load amps: _____

The tractor motor is meant to reactivate (forward) when the auger drive motor reaches 110% of the no load amps (amperage observed when the auger flight turns freely in absence of grain).

110% of no load amps: _____

Final Display Setup

NOTE: *If no keys are activated for 2 minutes, the display returns to the default state without saving any configuration changes. At each value, after 5 seconds of inactivity, a description of the current state will scroll across the display.*

Press OK repeatedly until RELU is displayed on the unit.

Press \uparrow or \downarrow on the display unit until DISP is shown (not PERC).

5. Assembly

Press OK.

REL1 should be displayed on the unit.

Press \uparrow or \downarrow on the display unit until SET is shown (not SKIP, or OFF).

Press OK.

SETP should be displayed on the unit.

Press \uparrow or \downarrow on the display unit the 90% of FLA value is shown.

Press OK.

ACT1 should be displayed on the unit.

Press \uparrow or \downarrow on the display unit until INCR is shown (not DECR).

Press OK.

HYS1 should be displayed on the unit.

For this control panel hysteresis (HYS1) is measured as the different between 90% of full load amps and 110% of no load amps.

90% of full load amps: _____ minus 110% of no load amps: _____

Press \uparrow or \downarrow on the display unit until the correct value is shown.

Press OK.

ERR1 should be displayed on the unit.

Press \uparrow or \downarrow on the display unit until DEAC is shown (not HOLD, ACTI, or NONE).

Press OK.

ON.DE should be displayed on the unit.

Press \uparrow or \downarrow on the display unit until 0 is shown.

Press OK.

OF.DE should be displayed on the unit.

Press \uparrow or \downarrow on the display unit until 20 is shown.

Press OK.

REL2 should be displayed on the unit.

Press \uparrow or \downarrow on the display unit until OFF is shown (not SET or SKIP).

Press OK.

E.PAS should be displayed on the unit.

Press \uparrow or \downarrow on the display unit until NO is shown.

Press OK.

This function will allow the values that were entered to be locked.

NOTE: *Using a password will stop access to the menu and parameters. There are two (2) levels of password protection. Passwords between 0000 and 4999 allow access to the fast set point adjustment and relay test. (Using this password stops access to all other parts of the menu.) Passwords between 5000 and 9999 stop access to all parts of the menu, fast set point adjustment and relay test. (Current set point is still shown.) By using the master password 2008, all configuration menus are available.*

If you select NO, press OK.

If you select YES, N.PAS will be displayed. Press \uparrow or \downarrow on the display unit until your password is shown. Press OK. Document this password.

The password will be necessary if there needs to be changes to many of the configuration values.

If the meter looks like this:

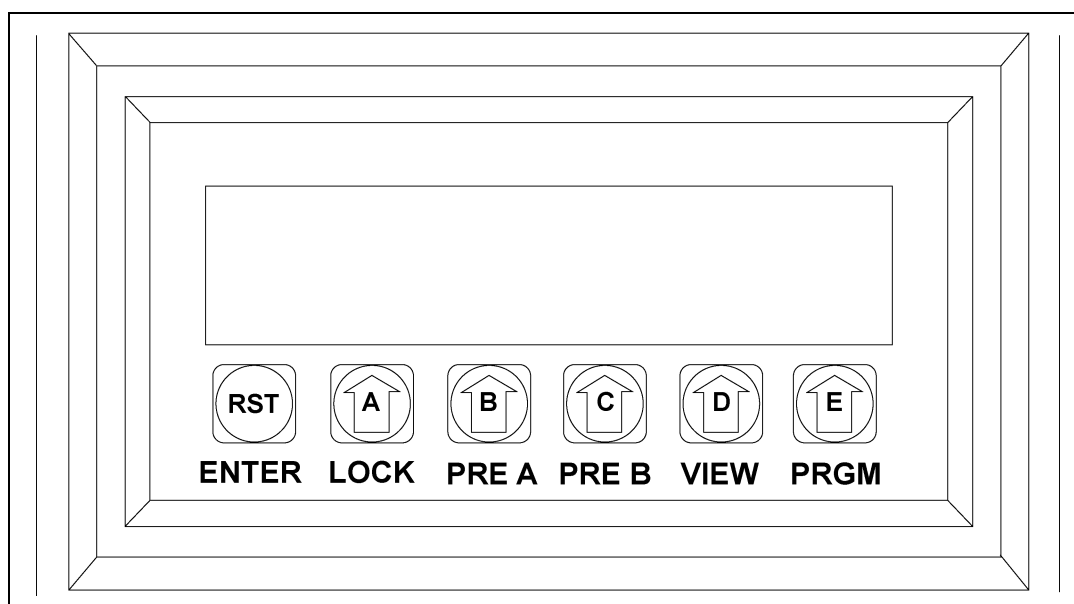

Figure 5AN

Follow these instructions:

NOTE: *In order to fine tune the control panel, the bin must have grain in it.*

The Series II Sweep is supplied with adjustable overloads that are not set at the factory. These should be set slightly higher than the Full Load Amp (FLA) value listed on the motor nameplates.

A. Find the desired “High” Amp and “Low” Amp set points.

1. **High Amp Set Point:** The Amp load the auger draws when the auger flighting is 90% loaded. This will turn OFF the tractor drive motor. Initially, set the value to 90% of the Full Load Amps (FLA) listed on the motor nameplate.
2. **Low Amp Set Point:** The Amp load the auger motor draws when the auger flighting is 10% loaded. This will turn ON the drive motor. Initially, set this value to 10% over the Amp draw of the sweep running empty.



NEVER program the “High Amp Set Point” greater than the full load running Amps of the auger motor.

5. Assembly

B. Programming the Amp Meter.

Calibration

1. Setting Input

- a. Press "PRGM" to "inPut".



- b. Press "ENTER".

- c. Press "PRGM" to "i4-20".



- d. Press "ENTER" to RUN MODE.



2. Setting Setup

- a. Press "PRGM" to "SEtUP".



- b. Press "ENTER" to "rdEC".

Use arrow buttons to change the decimal placement. Show .0 Amps.



- c. Press "ENTER" to "SETLO".

- d. Press "ENTER"

Value = 0.0



- e. Press "ENTER" to "SEtHi".

- f. Press "Enter"

Value = 50.0



Use arrow buttons to change value.

- g. Press "ENTER" to "LoCut".

Press "ENTER"

This value = 0



- h. Press "ENTER" to RUN MODE.



Operation

1. Setting Presets

- a. Press “Pre A”.
- b. Press “PRGM”
 - This value = “High Amp Set Point”.
 - Use arrow buttons to change value.
- c. Press “ENTER”.

2. Setting Relays

- a. Press “PRGM” to “rELAYS”.
- b. Press “ENTER” to “HYS A”.
- c. Press “PRGM”
 - This value = “High Amp Set Point”-“Low Amp Set Point”
 - Use arrow buttons to change value.

- d. Press “ENTER” to RUN MODE.



EXAMPLE: Full Load Running Amps = 21 Amps

High Amp Set Point = 20 Amps

Low Amp Set Point = 12 Amps

Then “HYS A” = 8 Amps

And “Pre A” = 20 Amps

NOTE: *This is the difference between the High Amp Set Point and the Low Amp Set Point.*
 $[20 \text{ Amps} - 12 \text{ Amps} = 8 \text{ Amps}]$. Low amp set point is only used to calculate this value.

3. Locking the Amp Meter

1. Locking the Amp meter is not required but prevents the meter from being tampered with once it is programmed.
2. In RUN MODE, press “LOCK” three (3) times within five (5) seconds.
 - This value = A number that is easily remembered.
 - Use arrow buttons to change value.
 - a. Press “ENTER”.

4. Unlocking the Amp Meter

1. In RUN MODE, press “LOCK” three (3) times within five (5) seconds.
 - a. Enter the “LoC” value.
 - Use arrow buttons to change value.
 - b. Press “ENTER”.

NOTE: *It is recommended to write down the “LoC” value and keep it in a safe place in case it is forgotten.*

6. Start-up

Perform Pre-start Checks



To ensure that the drive is not unexpectedly started, turn OFF and lock out the power source before proceeding. Failure to observe these precautions could result in bodily injury.



*Failure to perform any or all of these pre-start checks may cause damage to the equipment and/or cause **SERIOUS INJURY** or **DEATH** to those in the work area.*

Failure to perform any or all of these pre-start checks may also be a misuse of the equipment. Any misuse of the equipment may void the warranty.



***ALWAYS** keep **ALL** guards and shields in place, until all the power is disconnected and locked out.*

- A. Make sure ALL shields are in place.
- B. Inspect the drive unit for any problems or potential problems.
- C. Be aware of any emergency shut down procedures. Two (2) people must always be in position to monitor the operation of the equipment from outside the bin.
- D. Before starting the auger for the first time, make sure that all parts are assembled correctly according to the instructions in this manual.



Be sure to remove the grain from the drive chain and sprockets. If this is not done, damage can occur to the drive system.



*Make certain **ONLY** trained operators are in the work area before operating or moving the machine. Two (2) people must always be in position to monitor the operation of the equipment from outside the bin.*

Start the Auger



DO NOT start or stop the auger while it is under load.

- A. If equipped, plug the two (2) motors, foot switch and thermal protection cords into the bottom of the control panel while making sure they are locked into the receptacles. Each plug is different and can only be plugged into one receptacle to prevent accidental electric shock and/or overloads.
- B. Step on the foot switch and press the “Start” button.
- C. Run the auger through a “break-in” period if it is being used for the first time or for the first time of the season.
- D. “Polish” the flighting by running the auger at partial capacity until it is smooth, before attempting full capacity.



Failures may occur if the auger is run full before it has been “polished” during the “break-in” period.



NEVER operate the auger empty. Operating augers empty for any length of time will cause excessive wear. NEVER operate the auger at speeds higher than recommended.



Be aware of any unusual vibration or noises during the initial start-up and “break-in” period. If anything unusual is detected, immediately shut down the auger and disconnect and lock out the power supply before servicing.

Operating the Sweep Auger

CAUTION

Gear Reducer is shipped without oil. Add the proper amount of the recommended lubricant before operating. Failure to observe these precautions could result in damage to, or destruction of, the equipment.



Danger! Keep out of the bin while the bin sweep auger is in operation. The rapidly moving sweep auger can cause SERIOUS INJURY or DEATH!

NOTE: *The auger capacity can fluctuate greatly under varying conditions. Moisture content, different commodities, amount of foreign matter and speeds all play a part in the performance of the auger. Twenty-five percent (25%) moisture may cut capacity by as much as 40% under some conditions.*

- A. Make certain there are at least two (2) people in the work area to monitor operations at all times.
- B. Start the bin unloading equipment before starting the bin sweep auger.



Be alert for any unusual vibrations, noises and the loosening of any fasteners. If anything unusual is detected, immediately shut down the auger, disconnect and lock out the power source before servicing.

- C. Shut down the auger as soon as the bin is empty.
- D. Consideration should be given to the proper size auger for any intermittent type operations. When augers are stopped and restarted under full load, it may result in damage to the auger. Using a larger diameter auger and reducing its load level will be far better than subjecting a smaller diameter auger to big loads. If an auger is kept from absolute filling, it will make start-up easier and will convey more efficiently.



NEVER enter the bin while the bin sweep is in operation.

NEVER attempt to control the operation of the bin sweep by depressing the operating controls with shovels, brooms or any other objects.

DO NOT attempt to restrain movement of the bin sweep with ropes, bars or other devices.

NEVER allow an operator to attempt to manually restrain the bin sweep.

Operating the Sweep Auger Control Panel

A. The sweep operates in two (2) different “modes”.

1. Automatic (The auger motor runs and the drive motor runs using the Amp Meter in the control panel.)

Step on the foot switch and press the “Start” button. The auger motor will turn ON and the drive motor will turn ON only if the Amp Meter reaches the “Low” set point.

2. Manual (Overrides the Amp Meter and allows the operator to manually move the sweep.)

- a. Idle (Allows the auger motor to run, but does not move the sweep forward or reverse).
- b. Forward (Auger motor will run and moves the sweep towards the grain).
- c. Reverse (Stops the auger motor and moves the sweep away from the grain).

Step on the foot switch and press the “Start” button. The auger motor will turn, but the sweep will not move. Turn the “Manual” switch to “Forward” and the sweep will move forward towards the grain. Turn the “Manual” switch to “Reverse” and the auger motor will shut off and move the sweep backwards away from the grain.

The “Start” button MUST be pressed to start the auger motor again.

NOTE: *The foot switch MUST be depressed and the thermal protection must be connected before the sweep will operate.*

8. Shut Down

Normal Shut Down

- A. Before shutting down the unit, be sure the sumps and unload conveyor are empty.
- B. Press the “Stop” button on the control panel.

Emergency Shut Down

- A. Know how to shut down the auger in case of an emergency.
- B. Step off the foot switch and press the “Stop” button.
- C. Disconnect and lock out the power source.

CAUTION	<i>NEVER start the equipment under load. Doing so may cause damage. This type of damage is considered a misuse of the equipment. Any misuse of the equipment may void the warranty.</i>
----------------	------------------------------------------------------------------------------------------------------------------------------------------------------------------------------------------------

Storage Preparation

- A. Be sure the sumps and unload conveyor are empty.
- B. Close the sump control gates.
- C. Park the sweep behind the intermediate sumps, so that the sumps are on the auger side of the sweep.
- D. Shut down the auger.
- E. Make sure all fasteners are tight.
- F. After allowing the motors to cool down, cover the motors with the tarps supplied with the sweep.
- G. Place blocks under the frame of the sweep to help support the sweep during storage.

Maintain the Auger



ALWAYS shut down and disconnect the power supply before adjusting, servicing or cleaning the equipment.

- A. Use caution when repairing or replacing equipment parts.
- B. Make sure ALL decals are legible and securely attached to the auger. If necessary, replace them **FREE OF CHARGE** by contacting GSI at:

GSI
P.O. Box 20
1004 E. Illinois St.
Assumption, IL 62510
Phone: 1-217-226-4421

- C. Ensure that ALL electric motors, etc. are operating at the proper speed.
- D. Make sure ALL electrical wiring is not damaged and that it meets proper wiring codes.
- E. Make sure ALL components are in good working condition before use.

CAUTION

ALL SPEED REDUCERS ARE SHIPPED DRY. OIL MUST BE ADDED PRIOR TO OPERATION. Do not operate the unit without making sure it contains the correct amount of oil. Do not overfill or underfill with oil or injury to personnel, unit or other equipment may result.

CAUTION

Do not mix non-synthetic and synthetic oil in the unit.

Lubrication

A. Lubrication – Electric Motors

Electric motors supplied for use on Series II Sweeps are properly lubricated at the time of manufacture. It is not necessary to lubricate them at the time of installation unless the motor has been in storage for one year or longer. Some motors may be factory lubricated and sealed for the life of the bearings. Overgreasing the bearings can cause premature failure of the motor. The amount of grease added must be carefully controlled.

B. Procedure for Lubrication of Electric Motors

1. Stop motor. Disconnect and lock out of service.
2. Follow all safe bin entry procedures and wear all required personal protective equipment.
3. Remove contaminants from grease inlet area.
4. Remove filler and drain plugs.
5. Check filler and drain holes for blockage and clean as necessary.
6. Add proper type and amount of grease. [See Chart on Page 69](#) for amount of lubricant. Too much grease or injecting grease too quickly can cause premature bearing failure. Use approximately one minute to slowly inject the recommended amount of grease.
7. Wipe off excess grease and replace filler and drain plugs. Do not run motor without the grease and drain plugs installed.

NOTE: *It is very important to keep the grease clean. Mixing dissimilar grease is not recommended.*

C. Type of Lubrication

A polyurea mineral oil NGLI grade 2 type grease is to be used for lubrication of the electric motors. Grease meeting this specification include:

- | | |
|------------------|-------------|
| 1.) Chevron | SRI #2 |
| 2.) Exxon-Mobile | Polyrex EM |
| 3.) Texaco | Polystar RB |

D. Frequency of Lubrication

Motors should be relubricated after storage of one year or more or at the beginning of each season.

The following Chart gives the amount of grease to be added.

Lubrication - Electric Motors Quantity of Grease per Frame Size

For Baldor Brand Electric Motors		
NEMA Frame Size	Volume	
	Cu. in.	Fluid oz
56C		
143TC	0.25	0.14
182TC	0.5	0.28
184TC	0.5	0.28
213T	0.75	0.42
215T	0.75	0.42
254T	1	0.55
256T	1	0.55
284T	1.25	0.69
286T	1.25	0.69
324T	1.5	0.83

For Marathon Brand Electric Motors				
NEMA Frame Size	Volume			
	Cu. in.	Ounce	Gram	Teaspoon
56C				
143TC	0.6	0.3	8.4	2
182TC	0.6	0.3	8.4	2
184TC	0.6	0.3	8.4	2
213T	0.6	0.3	8.4	2
215T	0.6	0.3	8.4	2
254T	1.2	0.61	17.4	3.9
256T	1.2	0.61	17.4	3.9
284T	1.2	0.61	17.4	3.9
286T	1.2	0.61	17.4	3.9
324T	1.5	0.81	23.1	5.2

9. Maintenance

E. Lubrication – Reducers (Gear Boxes)

Reducers supplied for use on Series II Sweeps are shipped without lubricant (dry). The proper lubricant must be added at the time of installation. Over lubrication may cause premature failure of the reducer. The amount of lubricant must be carefully controlled.

F. Procedure for Initial Filling of Reducers

1. Disconnect and lock motor out of service. Do not run gear box without lubricant.
2. Follow all safe bin entry procedures and wear all required personal protective equipment.
3. Remove contaminants from inlet area.
4. Remove filler and oil level fill plugs.
5. Check filler holes for blockage and clean as necessary.
6. Clean the magnetic drain plug if one was supplied.
7. Add proper type of lubricant to fill level or until oil runs out of oil level fill hole.
See the Lubrication Chart on Page 71 for amounts and types of lubricant.
8. Wipe off excess lubricant and replace filler and oil level fill plugs.

NOTE: *It is very important to keep the lubricant clean. Mixing dissimilar lubricants is not recommended.*

G. Procedure for Changing of Lubricant

1. Stop motor. Disconnect and lock out of service.
2. Follow all safe bin entry procedures and wear all required personal protective equipment.
3. Remove contaminants from inlet and drain area.
4. Remove filler, oil level fill and drain plugs. Drain old lubricant from reducer.
5. Flush reducer with a nonflammable solvent such as Lubriplate Pure Flush or Whitmore's Flushing Oil.
6. Clean the magnetic drain plug if installed.
7. Carefully replace drain plug.
8. Add proper type of lubricant to fill level or until oil runs out of oil level fill hole.
See the Lubrication Chart on Page 71 for amounts and types of lubricant.
9. Wipe off excess lubricant and replace filler and oil level fill plugs.

NOTE: *It is very important to keep the lubricant clean. Mixing dissimilar lubricants is not recommended.*

H. Frequency of Lubrication

Lubricant should be changed after storage of one year or more or at the beginning of each season.

I. Type of Lubrication

The type and quantity of lubrication required for each type and size of reducer is listed in [the following Chart](#).

Lubrication - Gear Boxes Quantity and Type of Lubricant per Box Size

Foot-Jones (Screw Drive) Reducer		
Box Size	Volume	
	Quarts	Liters
8115	0.75	0.7
8203	1	0.95
8207	1.5	1.4
Lubrication Specification		
	Temp 15-60° F	Temp 50-125° F
	AGMA 3	AGMA 4
Chevron Oil Company	OC Turb. Oil 100	EP Machine Oil 150
Exxon Oil Company	Terrestic 100	Terrestic 150
Marathon Oil Company	Endurance Oil 30	Endurance Oil 40
Mobile Oil Company	DTE-18M	DTE Oil Extra Heavy
	Or Equal	

Hub City (Tractors Driver) Reducer		
Box Series	Volume	
	Pints Worm Top	Pints Worm Bottom
320	2.65	1.9
380	3.9	3.2
Lubrication Specification		
Mobile	SHC634-Synthetic	
	Or Equal	

EPT Browning (Screw Drive)		
Box Size	Volume (Quarts)	
107-09	2 Approx.	
115-09	2.56 Approx.	
203-09	4 Approx.	
207-09	6.3 Approx.	
215-09	9 Approx.	
Lubrication Specification		
Mineral Oil	Temp 15-60°F	Temp 50-125°F
	AGMA 4	AGMA 5
Mobile Oil Company	DTE Oil Extra Heavy	DTE-Oil BB
Synthetic Oil	Temp 0-90°F	Temp 15-125°F
	AGMA 4	AGMA 5
Mobile Oil Company	Mobile SHC 629	Mobile SHC 630

9. Maintenance

J. Lubrication – Bearings, Casters and Jacks

The flange bearings, pillow block bearings and casters supplied for use on Series II Sweeps are shipped from the factory lubricated. From time to time a small amount of the proper lubricant must be added. Over lubrication may cause premature failure of the components.

K. Procedure for Lubricating Flange and Pillow Block Bearings

1. Disconnect and lock motors out of service.
2. Follow all safe bin entry procedures and wear all required personal protective equipment.
3. Remove contaminants from the grease zerk and surrounding area.
4. Add proper type of lubricant. [See the Lubrication Chart on Page 73](#) for types of lubricant.
5. Wipe off excess lubricant.

NOTE: *It is very important to keep the lubricant clean.*

L. Procedure for Lubricating Casters

1. Disconnect and lock motors out of service.
2. Follow all safe bin entry procedures and wear all required personal protective equipment.
3. Remove contaminants from the grease zerk and surrounding area.
4. Add proper type of lubricant. [See the Lubrication Chart on Page 73](#) for types of lubricant
5. Wipe off excess lubricant.

NOTE: *It is very important to keep the lubricant clean.*

M. Procedure for Lubricating Jacks

1. Disconnect and lock motors out of service.
2. Follow all safe bin entry procedures and wear all required personal protective equipment.
3. Lubricate the gears using the grease zerk at the top of the jack. Rotate the jack handle to distribute the grease.
4. Lightly grease the inner tube of the jack using the same type of grease.
5. Apply a light weight oil to the handle unit at both sides of the tube.
6. Apply a light weight oil to the small hole at the upper end of the jack to lubricate the nut and screw assembly.

N. Frequency of Lubrication

The tractor drive pillow block bearings and the end flange bearing, along with the casters, should be lubricated after each use of the Series II Sweep. If possible, lubricate all the components at the beginning of each season or after long term storage.

O. Type of Lubrication

The type of lubrication required, for each component, is listed in *the following Chart*.

Lubrication - Bearings, Casters and Misc. Equipment Type of Lubricant		
Equipment	Lubrication Specification	
Tractor Drive Pillow Blocks	Shell Oil Company	Alvania #2 (or equivalent)
End Flange Bearing	Shell Oil Company	Alvania #2 (or equivalent)
Nylon Flight Bearings	None Required	None Required
Head End Casters	Shell Oil Company	Alvania #2 (or equivalent)
Jack Casters	Shell Oil Company	Alvania #2 (or equivalent)
Jacks	Shell Oil Company	Alvania #2 (or equivalent)

CAUTION

Too much oil will cause overheating and too little will result in gear failure. Check oil level regularly.

CAUTION

Extreme pressure (EP) lubricants are not recommended for average operating conditions. Failure to observe these precautions could result in damage to or destruction of the equipment.

CAUTION

Under Extreme operating conditions, such as rapid rise and fall of temperatures, dust, dirt, chemical particles, chemical fumes or oil sump temperature above 200°F, the oil should be changed every one to three months, depending on severity of conditions.

CAUTION

If the unit is used in the food or drug industry (including animal food) consult the petroleum supplier for recommendations on lubricants which meet the specifications of the FDA, USDA and/or other authoritative bodies having jurisdiction. Standard lubricants are not suitable for these applications or these industries.



WARNING

Oil, housings and other components can reach high temperatures during operation and can cause severe burns. Use extreme care when removing lubrication plugs and vents while servicing the unit.

NOTE: *The pour point of the lubricant selected should be at least 10°F lower than the expected minimum ambient starting temperature. Extreme pressure (EP) lubricants are not recommended for average operating conditions.*

10. Control Panel Diagrams

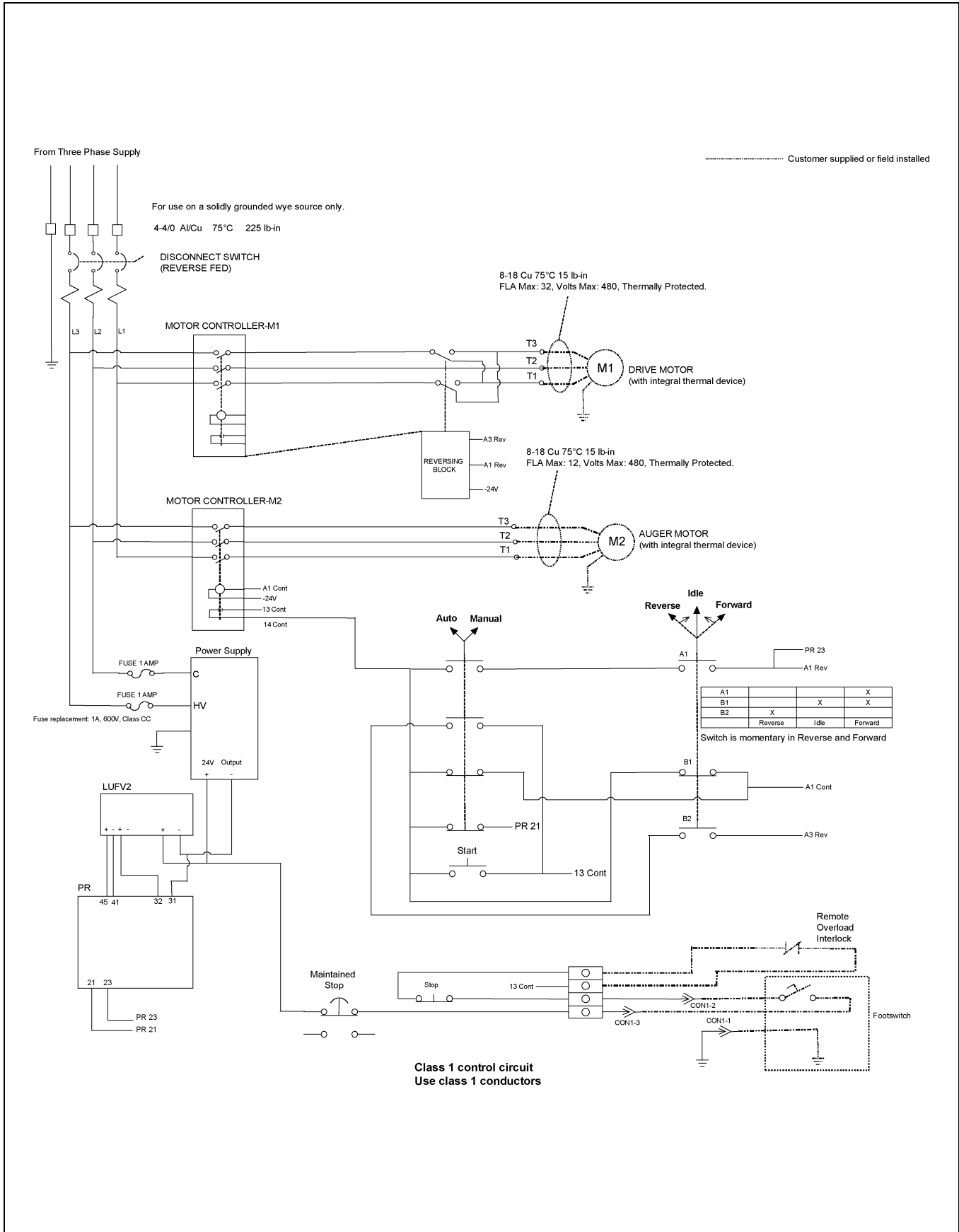
Control Panel Schematic (460/3/60) Post-May 2010



Control Panel Schematic (460/3/60) Pre-June 2010

NOTE: All wires are to be 18 AWG unless otherwise noted.

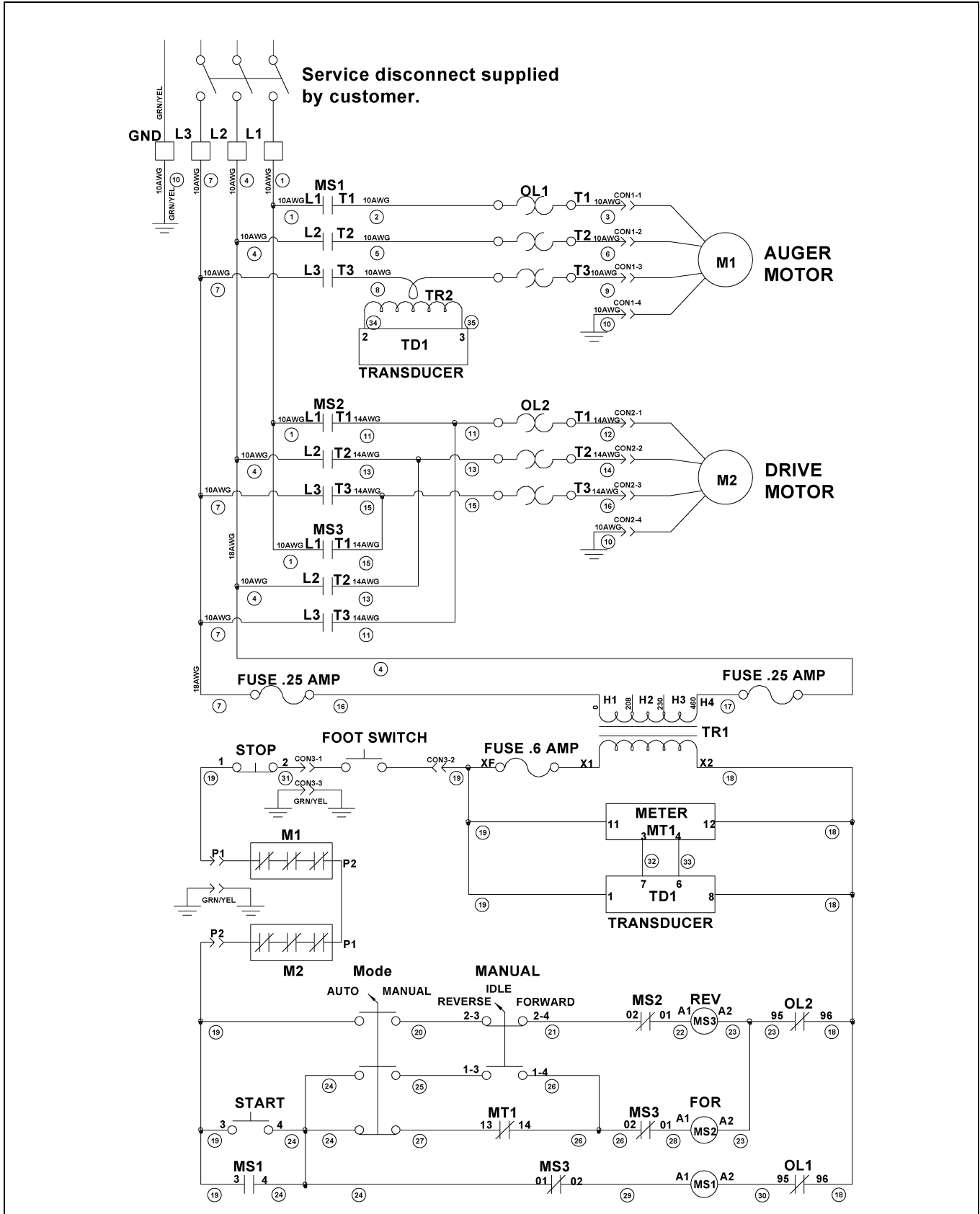

10. Control Panel Diagrams

Control Panel Schematic (230/3/60) Pre-June 2010

NOTE: All wires are to be 18 AWG unless otherwise noted.

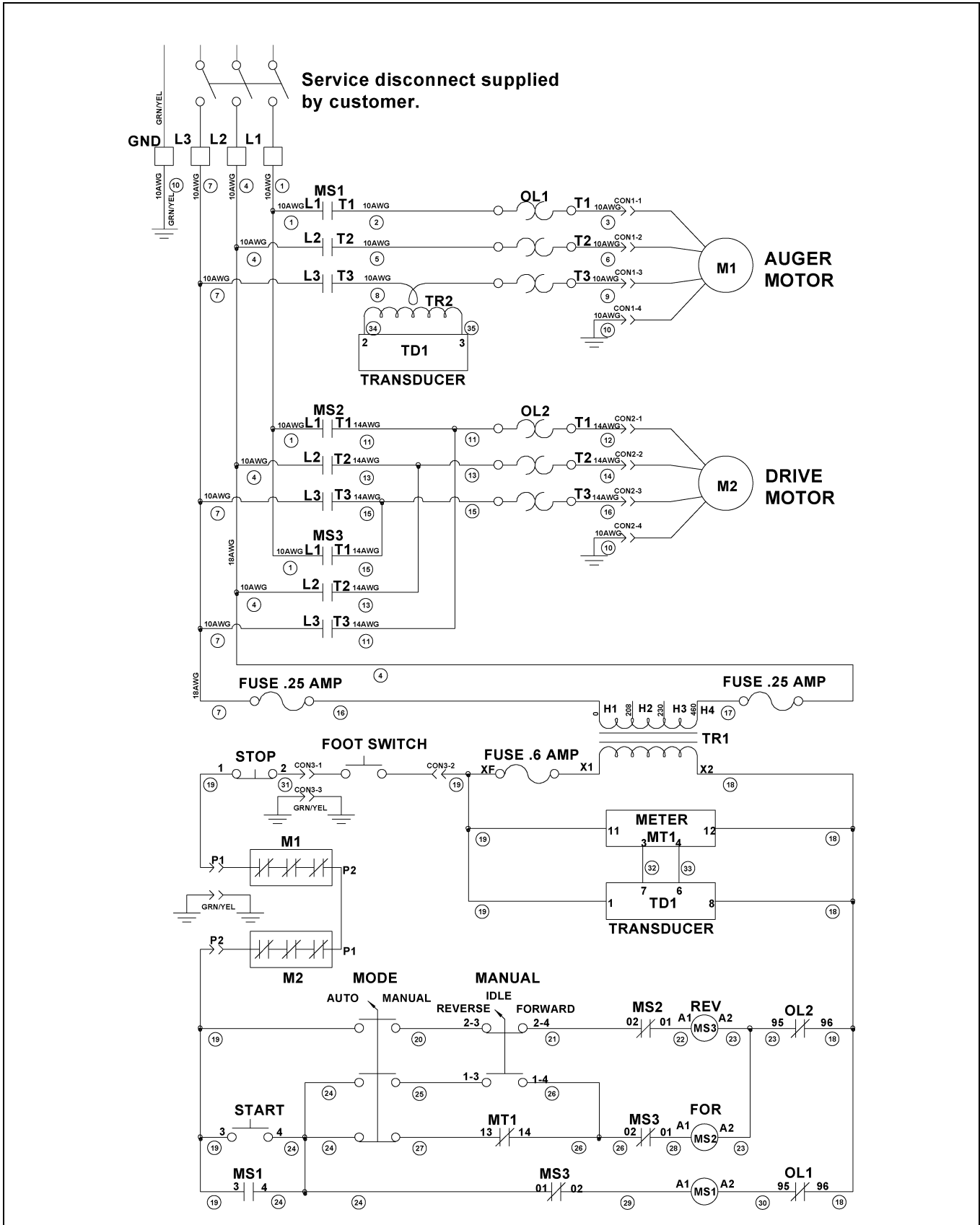

Control Panel Schematic (380/3/50) Pre-June 2010

NOTE: All wires are to be 18 AWG unless otherwise noted.

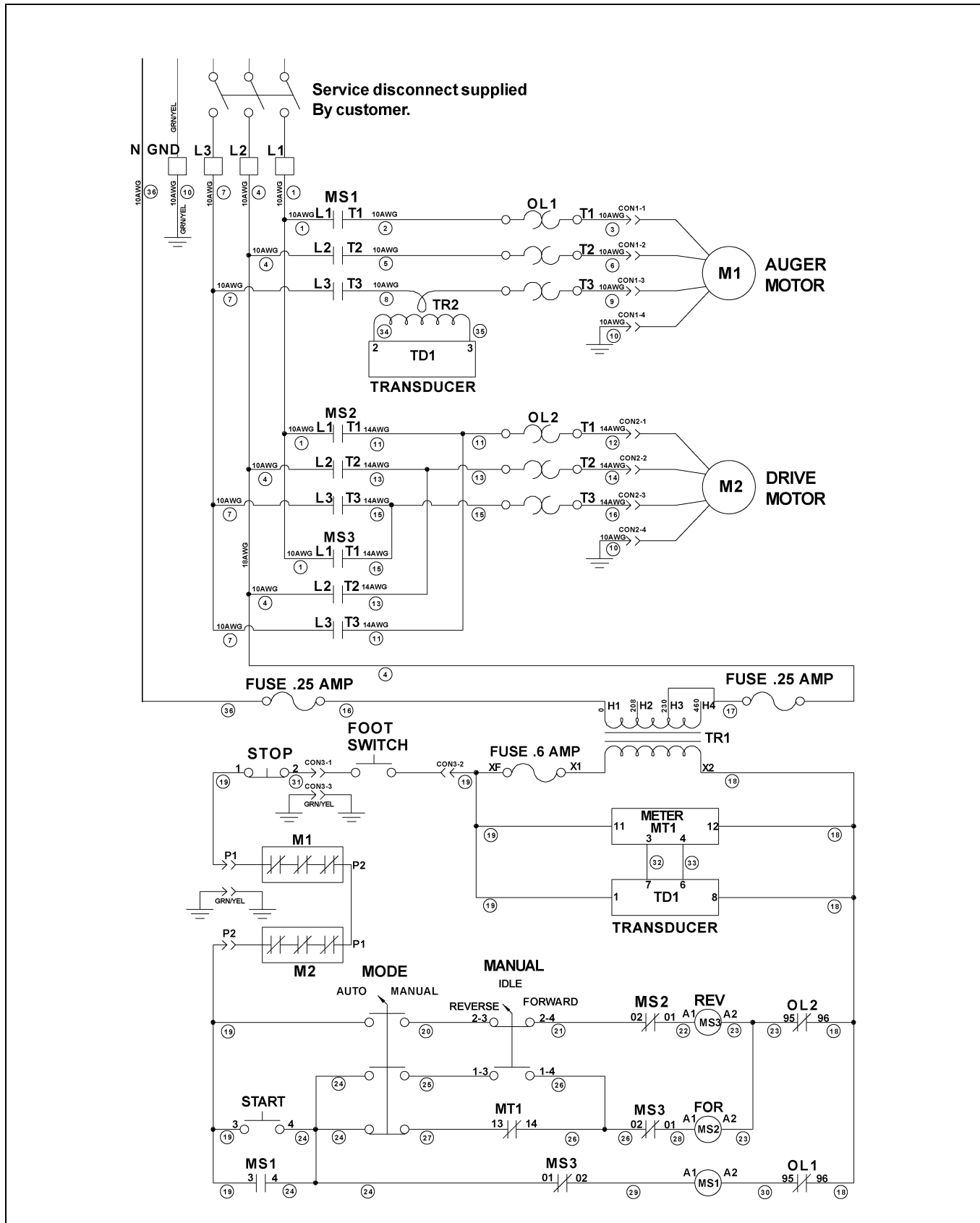

11. Troubleshooting

Problem	Possible Cause	Solution
1. Sweep does not run	1. Power cords may be unplugged or wiring may not have a good connection.	1. Plug in the power cords, check the wiring for loose connections.
	2. Foot switch may not be actuated.	2. Make sure the foot switch is depressed and the switch is operating properly.
	3. Overloads may be tripped.	3. Reset the overloads.
	4. Adjustable overloads not set correctly.	4. Set overload to 10% over the value listed on motor nameplate for full load amps.
2. Low capacity	1. The auger may not be fully loaded.	1. Make sure the grain is flowing into the auger, making it fully loaded.
	2. The auger is moving too slowly.	2. Check the auger speed. Low capacity results from speeds slower than recommended.
3. Sweep does not move around the bin	1. The control panel may not be in "Automatic Mode".	1. Turn the switch to "Automatic Mode".
	2. The amp meter is not properly adjusted.	2. Set the amp meter so the running amps of the auger motor turns ON the drive motor.
	3. The drive chain may be broken.	3. Repair the drive chain.
4. The sweep is vibrating	1. The auger may have foreign materials in it.	1. Remove the foreign material.
	2. The hanger bearings may be worn.	2. Replace the hanger bearings.
	3. The flight connections may be loose.	3. Tighten all of the flight connecting bolts.
	4. The flighting may be worn.	4. Replace all the flighting sections that are worn.

FAQs

Who do I contact for parts or service?

Contact your dealer. If your unit was purchased direct from GSI, contact your inside sales person.

What is/where do I find the model number of my sweep?

The model number of your sweep can be found on your quote or invoice. A space is provided at the front of your manual to record this number.

The model number code is as follows:

Style	Diameter	Size and Capacity	Voltage	Option 1	Option 2	Option 3
H	36'	-12 - 5	F			
K	***	-12 - 6	G	P	T	1
	135'	-12 - 7	J	B		
		-16 - 8	K	Q		
		-16 - 9				
		-16 - 10				

Standard H Welded Truss (36'-135')	GSI Standard Bin Diameter	-12 - 5 12" Flight and 5000 BPH	F 380/3/50	(Standard) Pin Center Sump Design, for Cables on the Floor (Not Through Sump)	(Standard - 36'- 120') V-Belt Flight PT, (Standard- 135') HT200 Flight PT	(Standard) GSI Flight PT HP
		-12 - 6 12" Flight and 6000 BPH	G 575/3/60			
		-12 - 7 12" Flight and 7000 BPH	J 415/3/60			
Knockdown K Truss (Not Available above 120')		-16 - 8 16" Flight and 8000 BPH	K 460/3/60	P Center Protected Cables or Center Slip Ring	T (36'-120') HT200 Flight PT	1 Increased Flight PT HP
		-16 - 9 16" Flight and 9000 BPH		B Control Panel Not Included		
		-16 - 10 16" Flight and 10000 BPH		Q Same as P + B		

11. Troubleshooting

Do I want to buy a pivot or a standard sweep? What is the difference?

The following drawing ([Figure 11A](#)) is of a 16" pivot sweep head end weldment and a 16" standard sweep head end weldment. There are very few differences between the two. The standard head weldment has the female pivot tube welded to the drive end of the unit. Two (2) plate braces and one pipe brace support this tube. The pivot head weldment has a lug welded to the underside of the motor mount plate. This lug is for attachment of the sweep pivot rod assembly. There is a large hole in the rear plate for the center support tube assembly to pass through. Next to the large hole is a slot that the center support mounts to.

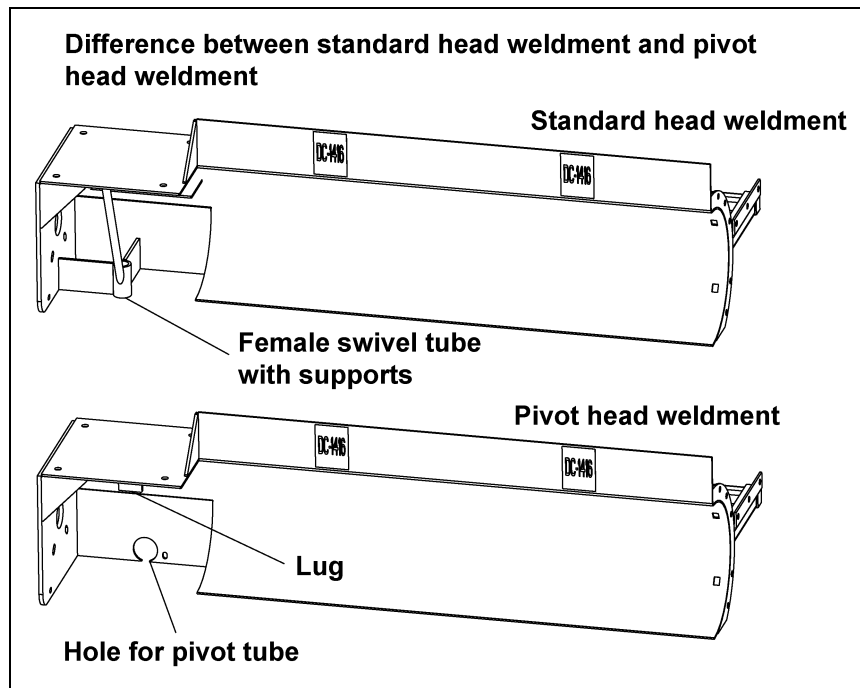

Figure 11A

How complete is the Series II Sweep?

With the exception of a few electrical connectors, all components required to assemble your sweep are included.

How level does my floor need to be for the sweep to operate properly?

The top edge of the sump hopper and the top edge of the "X" brace support must be level with the floor. The floor must be level within 3/4" plus or minus, preferably less. Any high or low points must be gradually sloped. The change in elevation should be no more than 3/4" over 60".

Where should the center pivot pin be located?

The center pin or pivot pipe **must** be in the center of the bin. If it is not, the sweep could hit the bin wall. There should be between 2" and 14" of clearance between the end of the sweep and the closest obstruction (bin wall, stiffeners, etc.).

How round must my bin be for the sweep to operate properly?

Diameter tolerances are limited by foundation limits and sweep operation as well as structural issues. For 72' diameter and larger bins, the overall tolerance would be plus or minus 1-1/4" on the radius, plus or minus 1" on 42'-66' diameter bins and plus or minus 3/4" on 30'-39' bins.

How large of an opening do I need for a standard flow (15000 BPH) center sump?

If installing a 12" standard sweep (non-pivot), the minimum recommended sump opening is 36" x 36". With a 16" standard sweep, it is 42" x 42".

If installing a 12" standard sweep with a pivot kit, the minimum recommended sump opening is 36" x 36". With a 16" standard sweep, it is 42" x 42". The cross brace (spider) is designed to fit a standard 42" x 42" sump, but the arms can be cut by the customer to fit a smaller opening. The top of the sump center brace weldment must be level with the top of the floor.

If installing a GSI supplied sump shell with collector ring, the opening must be 42-1/2" x 42-1/2" x 30" deep for either the 12" or 16" sweep.

The sump hopper supplied by GSI was designed with sufficient clearance around the collector ring housing to allow grain to gravity flow through the hopper and be carried away by the material handling equipment below it. 42-3/4" is the maximum opening size to allow rolling clearance for the casters assembled to the head end jack. If the sump is made smaller, grain flow may decrease to an unacceptable level.

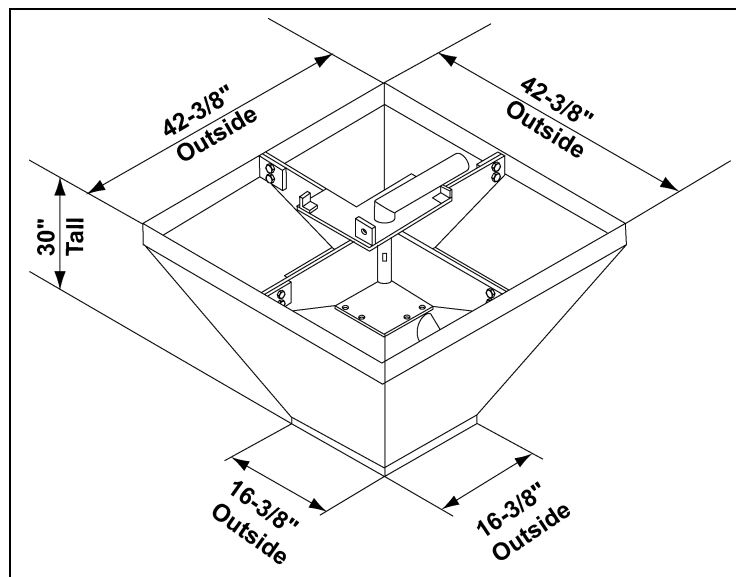

Figure 11B

The open area of this sump is misleading. The collector ring housing sticks down into the sump, blocking off a portion of the flow. Also, the sweep covers about one quarter of the opening at the top. We use 75% of the theoretical flow around the housing for the actual flow.

What intermediate sump spacing do I need? Why?

It is required to install the intermediate sumps on a maximum of 10' centers where the sweep will be parked during storage. The first intermediate sump should be placed a maximum of 10' on center from the center sump and the end sump should be no farther than 4' from the bin wall. The extra sumps will help clean out the grain in front of the sweep, reducing the start-up load. Doing this will save labor dollars and hours of work to dig out the sweep and will help the sweep during start-up. The sweep is not designed to start-up when submerged in material. The sweep should be parked behind the intermediate sumps with the sumps on the auger side of the sweep.

Do I need to clean out around the end of the sweep prior to starting it up?

Enough material must be removed from around the tractor drive and the screw drive units to allow access to the motor/drive covers. Both the chain drive and the belt drive must be free of grain before and during operation.

11. Troubleshooting

Where do I park the sweep before I fill the bin with grain?

There is a section in the manual called "[Storage Preparation on Page 66](#)". The section says to "Park the sweep behind the intermediate sumps, so that the sumps are on the auger side of the sweep". The sweep should not completely cover the inside sump hole (the one closest to the center sump). You will have to clean out around the tractor drive and the jack wheels before operation.

Where do I find the track dimensions?

The wheel path dimensions are listed at the front of the owner's manual. Your dealer also has a copy of the path dimensions in his price book. The head jack wheels are not listed on the chart. These are always 34" from the center of the bin. The area around the center sump must be kept clear for the head jack wheels to roll.

What do I need to hook electrical power to the Series II Sweep?

The Series II Sweep is designed to operate using **460 Volt 3 Phase 60 Cycle Power**. The voltage must be within **plus or minus 4%** for proper operation. Voltages outside of this range may cause excessive power draw or other operating problems. Please contact the factory for applications outside of these parameters.

A fused main power disconnect switch capable of being locked only in the OFF position should be used. This switch must be sized for the screw and tractor drive motors. The power must be locked out before servicing the equipment, entering the bin, or resetting the motor overloads. After June 2010, this switch is included in the control panel.

Electrical controls and wiring should be installed by a qualified electrician. The conductor cables should comply with the National Electrical Code and any state or local codes which may apply.

How does the Series II Sweep operate?

The Series II Sweep is designed with a small controller in the control panel door to monitor the load on the screw motor. It automatically shuts the tractor drive OFF when the screw motor reaches a percentage of the motor nameplate full load amperage. As the material clears the screw, the amperage lowers until it reaches a set value and the tractor drive turns back on and moves the screw into the material. The customer must program the set points into the controller and this setup is fully explained in the Owner's Manual. We usually start the high set point at approximately 90% of full load amps (FLA) listed on the motor nameplate and the low set point at 60% of the FLA.

Can I use the same control panel for different size sweeps?

If the different size sweeps use the same size motors, the same control panel can be used for different sweeps. The controller must be reprogrammed for each sweep.

Why does the controller need to be located at the bin door?

The control panel **MUST** be mounted **OUTSIDE** the bin near the door for safety reasons. It must be located so the operator has a full view of the equipment. It must **NEVER** be installed inside the bin.

Why do I need a foot switch?

The foot switch has to be plugged into the control panel and depressed before the sweep is operational. It has a 10' cord so the sweep can only be monitored from **OUTSIDE** the bin.

Can I just run my sweep in the manual mode?

The Series II Sweep is designed to run in the automatic mode. If the sweep is run in the manual mode, either of the motors may overheat and/or become damaged. Also, excessive amounts of material may spill over the back board of the sweep.

How do I set my overloads?

The overloads for both motors are adjustable and are not set at the factory. The overload inside the control panel has a small, usually yellow, dial with numbers on it. Record the full load running amp value listed on the nameplate attached to each motor. Increase the full load amp value by 10% and set this number on the overload dial. If the adjustable overloads are set too low, the motors will shut down as soon as a load is put on them. Disconnect and lock out the power before resetting the motor overloads.

When do I program my controller?

Initially the sweep should be tested in the manual mode. If it operates properly, then move on to try the automatic mode.

How do I program my controller for automatic mode?

The Owner's Manual has a detailed set of instructions describing the setup of automatic mode. The final programming must be performed with material in the tank.

What are the four receptacles in the bottom of the control panel for?

The four receptacles in the bottom of the control box are for the screw drive power, the tractor drive power, the motor overloads and the foot switch. Each receptacle is keyed differently to prevent mixing the cables.

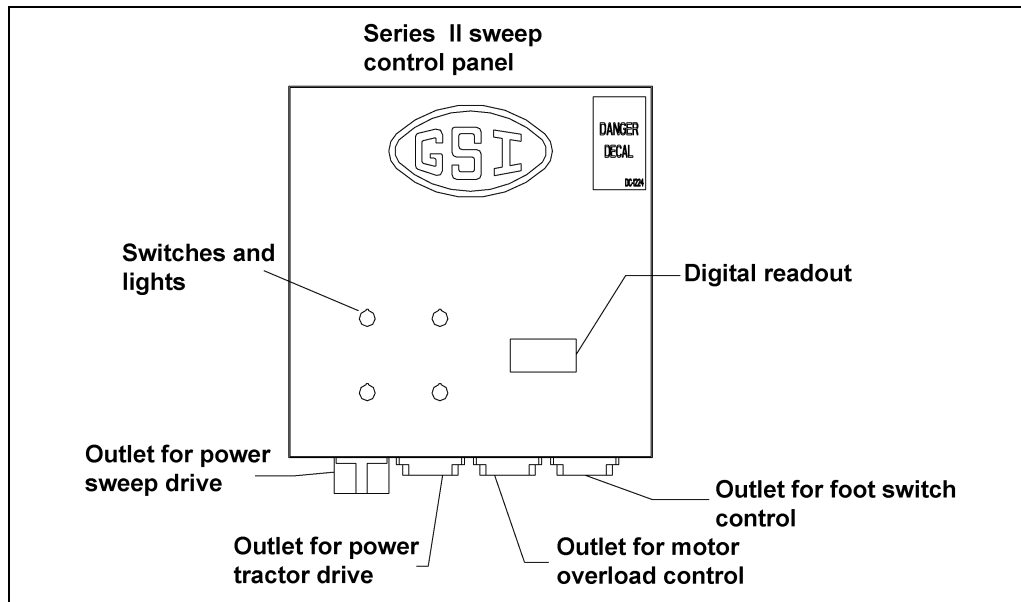

Figure 11C

Why doesn't the auger run while tractor drive is in reverse?

This is a safety feature of the Series II Sweep.

Can I get the unit to reverse while in automatic?

No. This is another safety feature of the Series II Sweep.

11. Troubleshooting

What do I do if I encounter any operational problems?

Disconnect and lock out the power before servicing the equipment, entering the bin, or resetting the motor overloads. Look through the troubleshooting section to identify any problems.

There does not seem to be any power to my sweep. What do I do?

Check to be sure the foot switch is plugged into the control panel and depressed. The foot switch has a 10' cord so the sweep can only be monitored from OUTSIDE the bin.

The thermal protection cord must be connected and plugged in before the sweep will operate.

Your electrician should check to make sure there are no loose or shorted connections or wires. It is possible that one of the components failed after it was tested in our plant and needs to be replaced. A jobsite electrician can isolate any malfunctioning components. Each fuse should also be checked and replaced if necessary.

The sweep must be wired according to the Owner/Installation Manuals.

The overload for the screw drive keeps tripping. What do I do?

The overloads for both motors are adjustable. These are not set at the factory prior to delivery and installation. The overload inside the control panel has a small, usually yellow, dial with numbers on it. Record the full load running amp value listed on the nameplate attached to each motor. Increase the full load amp value by 10% and set this number on the overload dial. If the adjustable overloads are set too low, the motors will shut down as soon as a load is put on them. Disconnect and lock out the power before resetting the motor overloads.

Check the incoming power at the control box. The Series II Sweep is designed to operate using **460 Volt 3 Phase 60 Cycle Power**. The voltage must be within **plus or minus 4%** for proper operation. Voltages outside of this range may cause excessive power draw or other operating problems. Please contact the factory for applications outside of these parameters.

Check the incoming power at the motor. Check for balanced phases. If the loads are not properly balanced between leads, disconnect the motor and check the power leads. By using this method, we can tell if the imbalance is caused by the motor or is from the incoming power.

The sweep must be wired according to the Owner/Installation Manuals.

My tractor drive seems to start and stop too often in automatic. What do I do?

The HYS A (High set point minus low set point) may be set with too large a number. To get maximum capacity from the sweep, this number should be set as small as possible and not have grain spill over the sweep backboard.

My controller quits operating. What do I do?

Check to make sure the controller has power. Each of the fuses should be checked and replaced if required.

If the controller is functioning, it may need to be reprogrammed. Programming instructions are included in the manual that shipped with the sweep. The controller can be damaged by large power fluctuations or lightning strikes.

My sweep is not operating as well as it did the last time I used it. What do I do?

If the type of material or the density (moisture) of the material changes, the controller set points may need to be adjusted for maximum output.

Is there any maintenance I need to perform on the electrical system?

None of the electrical components require maintenance. Be sure to disconnect and lock out the power before servicing the equipment, entering the bin, or resetting the motor overloads.

Does any part of the Series II Sweep need lubrication?

The fluid level of each of the gear reducers must be checked before operation. These reducers may have been shipped dry and require oil before operation.

A complete lubrication section is provided in the Owner's Manual, which shows the type and amount of lubricant to be used and which components need to be lubricated.

What maintenance should I perform and how often?

Follow the lubrication instructions in the Owner's Manual. Also visually inspect the sweep before operation.

What should I visually inspect?

Starting from the drive end of the sweep:

Inspect the head jack, caster mounting channel and head casters. Look for any bent or damaged components.

Inspect the motor covers. They should be in good shape and should be used properly. If the covers are not used, the material will work its way into the motor cooling slots and when the sweep is started, the motor fan and housing will be destroyed.

Inspect the belt guard for damage. Make sure there is no material inside the belt guard. The drain pan at the bottom of the guard can be used if required.

Inspect the drive belts, sheaves and bushings. Check the belts for proper tension. Sheaves and bushings should be tight.

Inspect the intermediate jacks for any broken or damaged components. Check the jack wheels for damage. The jacks should operate freely.

Inspect each of the screw flight bearings and hangers for damage. Check to see if the bearings need to be replaced. All hardware should be tight.

Inspect the screw flights for damage or excessive wear. Check to see if the screws are rusted or pitted.

Inspect the end bearing for damage.

Inspect the end caster (if one was originally supplied) to confirm it is working properly or if it needs to be replaced.

Inspect the tractor drive chain guard for damage. Make sure there is no material (grain) inside the chain guard. If there is any material (grain), drain pan which is at the bottom of the guard can be used to empty the guard.

Inspect the drive chain for damage and proper lubrication. Check for proper tension and confirm the sprockets and bushings are tight.

Inspect the tractor drive tires for damage or tread wear. Be sure the lug nuts are tight and tires are installed with the tread direction as shown in the manual.

Inspect the bearings for damage or excessive wear. Replace if necessary.

Inspect the tractor drive motor and gear reducer for damage or excessive wear.

Make sure all hardware is tight.

Inspect the sweep structure for damaged or bent components.

NOTES

- 1. Main Auger Components**
- 2. Flight Components**
- 3. End Bearing Components**
- 4. Auger Drive Components**
- 5. Drive Assembly**
- 6. Tractor Chain Guard Parts**
- 7. Motor Mount Jack and Base Assembly (GC09993)**
- 8. All 12" Sweep Jack Supports and 16" Jack Supports after 11-01-04**
- 9. Old Style 16" Sweep Jack Support (Before 11-01-04)**
- 10. Control Panel Components Pre-June 2010**
- 11. Weight Extension Kit (GC08144)**
- 12. Components**

Main Auger Components Parts List

Ref #	Part #	Description	Ref #	Part #	Description	
1	GC07282	S2 Sweep Head Section 12" x 60" Std	3	GC10193	S2 Sweep Tail Section 12" x Std	
	GC07250	S2 Sweep Head Section 12" x 72" Std		GC10194	S2 Sweep Tail Section 12" x Ext	
	GC07251	S2 Sweep Head Section 12" x 84" Std		GC10191	S2 Sweep Tail Section 16" x Std	
	GC07252	S2 Sweep Head Section 12" x 96" Std	GC10192	S2 Sweep Tail Section 16" x Ext		
	GC07253	S2 Sweep Head Section 12" x 108" Std	N/S	GC07086	S2 Sweep Ext Section 12" x 48"	
	GC10319	S2 Sweep Head Section 12" x 120" Std		GC07271	S2 Sweep Ext Section 12" x 84"	
	GC07125	S2 Sweep Head Section 12" x 132" Std		GC07272	S2 Sweep Ext Section 12" x 132"	
	GC07079	S2 Sweep Head Section 12" x 144" Std	GC07160	S2 Sweep Ext Section 16" x 48"		
	GC07254	S2 Sweep Head Section 12" x 60" Pvt	GC07087	S2 Sweep Ext Section 16" x 84"		
	GC07255	S2 Sweep Head Section 12" x 72" Pvt	GC07273	S2 Sweep Ext Section 16" x 132"		
	GC07256	S2 Sweep Head Section 12" x 84" Pvt	4	GC06608	S2 Sweep Head Flight 12" x 56-3/4"	
	GC07531	S2 Sweep Head Section 12" x 96" Pvt		GC06609	S2 Sweep Head Flight 12" x 68-3/4"	
	GC07258	S2 Sweep Head Section 12" x 108" Pvt		GC06610	S2 Sweep Head Flight 12" x 80-3/4"	
	GC10320	S2 Sweep Head Section 12" x 120" Pvt		GC07528	S2 Sweep Head Flight 12" x 92-3/4"	
	GC07077	S2 Sweep Head Section 12" x 132" Pvt		GC06612	S2 Sweep Head Flight 12" x 104-3/4"	
	GC07078	S2 Sweep Head Section 12" x 144" Pvt		GC06613	S2 Sweep Head Flight 12" x 116-3/4"	
2	GC07285	S2 Sweep Head Section 16" x 60" Std		GC06614	S2 Sweep Head Flight 12" x 128-3/4"	
	GC07260	S2 Sweep Head Section 16" x 72" Std		GC06465	S2 Sweep Head Flight 12" x 140-3/4"	
	GC07261	S2 Sweep Head Section 16" x 84" Std		5	GC06755	S2 Sweep Head Flight 16" x 55-5/8"
	GC07262	S2 Sweep Head Section 16" x 96" Std			GC06757	S2 Sweep Head Flight 16" x 67-5/8"
	GC07263	S2 Sweep Head Section 16" x 108" Std	GC06758		S2 Sweep Head Flight 16" x 79-5/8"	
	GC10822	S2 Sweep Head Section 16" x 120" Std	GC06760		S2 Sweep Head Flight 16" x 91-5/8"	
	GC07264	S2 Sweep Head Section 16" x 132" Std	GC06759		S2 Sweep Head Flight 16" x 103-5/8"	
	GC07081	S2 Sweep Head Section 16" x 144" Std	GC06761		S2 Sweep Head Flight 16" x 115-5/8"	
	GC07265	S2 Sweep Head Section 16" x 60" Pvt	GC06756		S2 Sweep Head Flight 16" x 127-5/8"	
	GC07266	S2 Sweep Head Section 16" x 72" Pvt	GC06637		S2 Sweep Head Flight 16" x 139-5/8"	
	GC07267	S2 Sweep Head Section 16" x 84" Pvt	GC06622		S2 Sweep Inter. Flight 12" x 58"	
	GC07268	S2 Sweep Head Section 16" x 96" Pvt	GC06623		S2 Sweep Inter. Flight 12" x 70"	
	GC07269	S2 Sweep Head Section 16" x 108" Pvt	GC06624	S2 Sweep Inter./Ext Flight 12" x 82"		
	GC10823	S2 Sweep Head Section 16" x 120" Pvt	GC06582	S2 Sweep Inter. Flight 12" x 94"		
	GC07270	S2 Sweep Head Section 16" x 132" Pvt	GC06626	S2 Sweep Inter. Flight 12" x 106"		
	GC07080	S2 Sweep Head Section 16" x 144" Pvt	GC06627	S2 Sweep Inter. Flight 12" x 118"		
2	GC07061	S2 Sweep Inter. Section 12" x 60"	GC06467	S2 Sweep Inter./Ext Flight 12" x 130"		
	GC07062	S2 Sweep Inter. Section 12" x 72"	GC06466	S2 Sweep Inter./Tail Flight 12" x 142"		
	GC07063	S2 Sweep Inter. Section 12" x 84"	N/S	GC06762	S2 Sweep Inter. Flight 16" x 57"	
	GC07064	S2 Sweep Inter. Section 12" x 96"		GC06764	S2 Sweep Inter. Flight 16" x 69"	
	GC07065	S2 Sweep Inter. Section 12" x 108"		GC06768	S2 Sweep Inter./Ext Flight 16" x 81"	
	GC07066	S2 Sweep Inter. Section 12" x 120"		GC06638	S2 Sweep Inter. Flight 16" x 93"	
	GC07067	S2 Sweep Inter. Section 12" x 132"		GC06763	S2 Sweep Inter. Flight 16" x 105"	
	GC07068	S2 Sweep Inter. Section 12" x 144"		GC06766	S2 Sweep Inter. Flight 16" x 117"	
GC07069	S2 Sweep Inter. Section 16" x 60"	GC06644		S2 Sweep Inter./Ext Flight 16" x 129"		
GC07070	S2 Sweep Inter. Section 16" x 72"	GC06639		S2 Sweep Inter./Tail Flight 16" x 141"		
GC07071	S2 Sweep Inter. Section 16" x 84"	GC06468		S2 Sweep Ext Flight 12" x 46"		
GC07072	S2 Sweep Inter. Section 16" x 96"	GC06767		S2 Sweep Ext Flight 16" x 45"		
GC07073	S2 Sweep Inter. Section 16" x 108"					
GC07074	S2 Sweep Inter. Section 16" x 120"					
GC07075	S2 Sweep Inter. Section 16" x 132"					
GC07076	S2 Sweep Inter. Section 16" x 144"					

Main Auger Components (Continued)

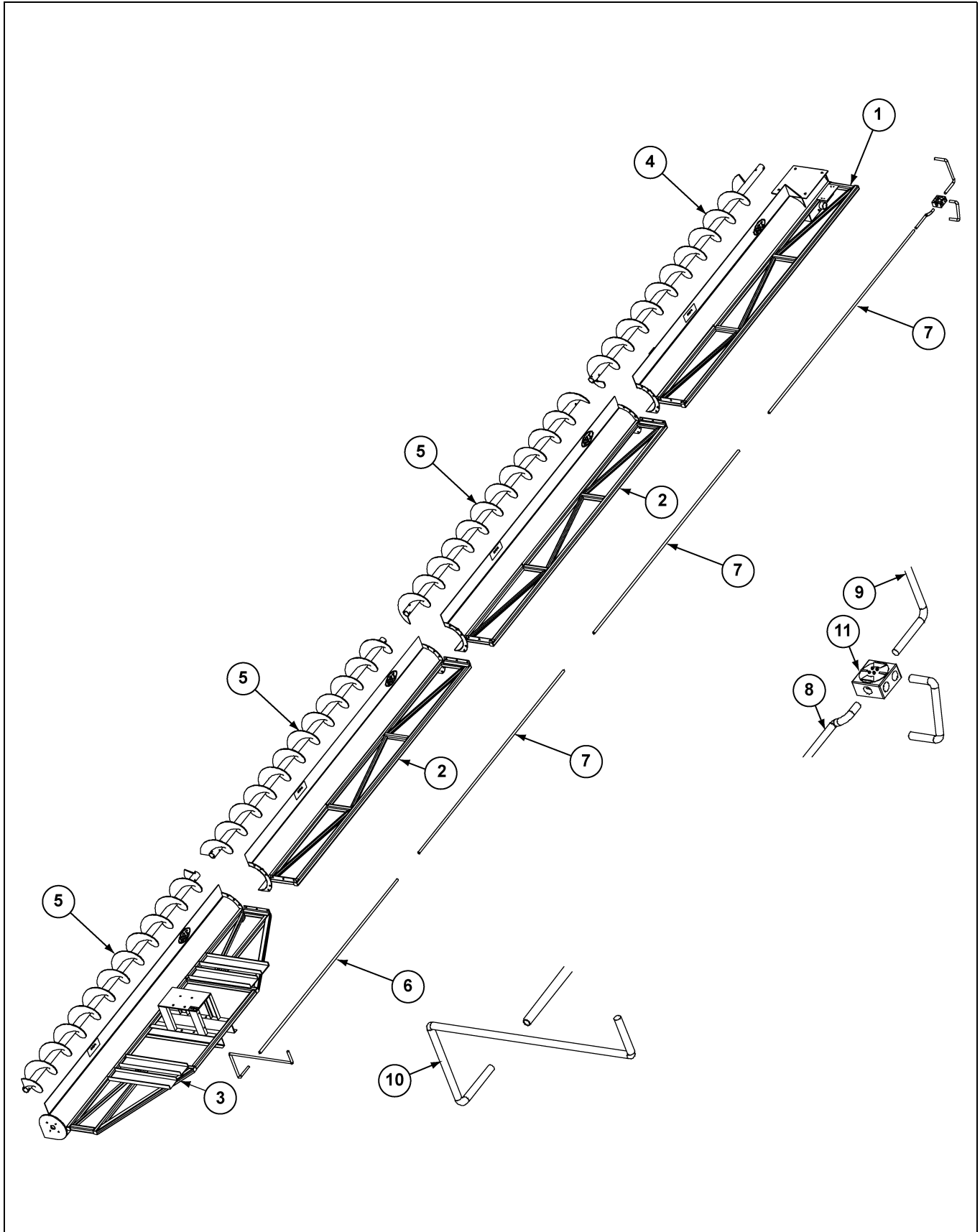

Main Auger Components Parts List

Ref #	Part #	Description
6	GC06722	Conduit 3/4" Rigid x 12"
	GC07533	Conduit 3/4" Rigid x 24"
	GC09815	Conduit 3/4" Rigid x 36"
	GC06934	Conduit 3/4" Rigid x 48"
	GC03798	Conduit 3/4" Rigid x 60"
	GC06075	Conduit 3/4" Rigid x 72"
	GC06877	Conduit 3/4" Rigid x 84"
	GC03492	Conduit 3/4" Rigid x 96"
	GC03797	Conduit 3/4" Rigid x 108"
7	S-6197	Conduit 3/4" Rigid x 120"
8	GC07523	Conduit 3/4" Flex x 12"
9	GC04862	Conduit 3/4" Flex x 40"
10	GC03800	Conduit 3/4" Flex x 48"
N/S	S-6196	Conduit Coupling x 3/4"
N/S	S-6198	Conduit Coupling Flex x 3/4"
N/S	S-8411	Conduit Clamp 1 Hole ZN 1"
N/S	TFC-0054	Conduit Flex 90D Elbow x 3/4"
N/S	S-8513	Conduit Reducer Bush 1" to 3/4"
N/S	GC07744	Conduit Nipple 1" x 4-3/4"
N/S	1EL0428	Connector Cord (8/4 Cable) 3/4" x 7/8"
N/S	S-4284	Connector Cord (10/4Cable) 5/8" to 3/4"
N/S	S-4283	Connector Cord (14/4Cable) 1/4" to 5/8"
11	GC07521	Junction Box-Expl Proof

Flight Components

12" Flight Connection Components

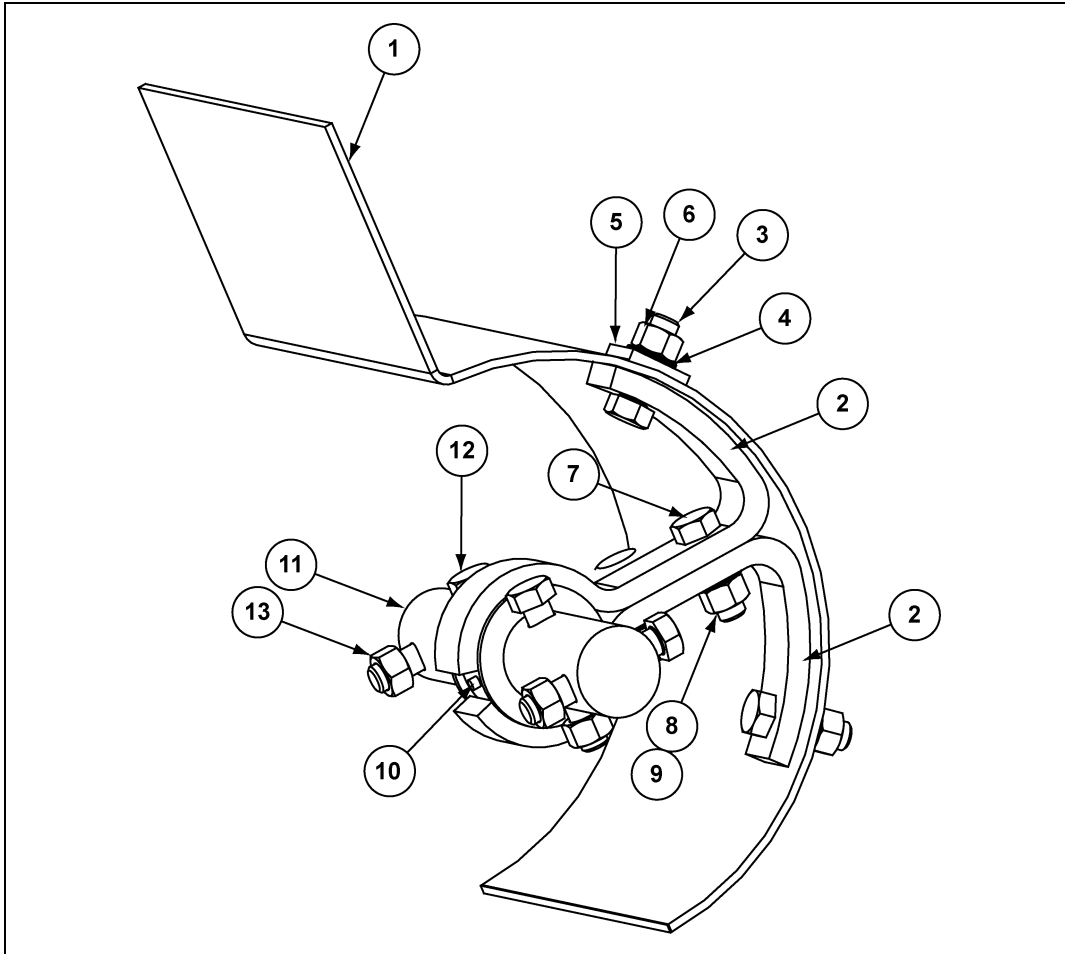

Ref #	Part #	Description	Qty Per Connection
1		Intermediate Shroud - 3/16" x 12"	N/A
2	GC06000	Hanger Bearing Bracket for 12" Sweep	2
3	S-4329	Bolt, HHCS 5/8"-11 x 2" ZN Grade 8	2
4	S-3208	5/8" Lock Washer	2
5	S-8423	Washer, Flat SQ 11/16" ZN	2
6	S-4110	Nut, Hex 5/8"-11 ZN Grade 5	2
7	S-8399	Bolt, HHCS 5/8"-11 x 2" ZN Grade 5	2
8	S-3208	5/8" Lock Washer	2
9	S-7597	Nut, Hex 5/8"-11 ZN	2
10	GC07701	Nylon Bearing: 2"	2
11	GC03956	2" Coupling Stub	1
12	S-7011	Bolt, HHCS 5/8"-11 x 3-1/2" ZN Grade 8	4
13	S-6494	Nut, Lock 5/8"-11 ZN Grade 5 Deformed	4

16" Flight Connection Components

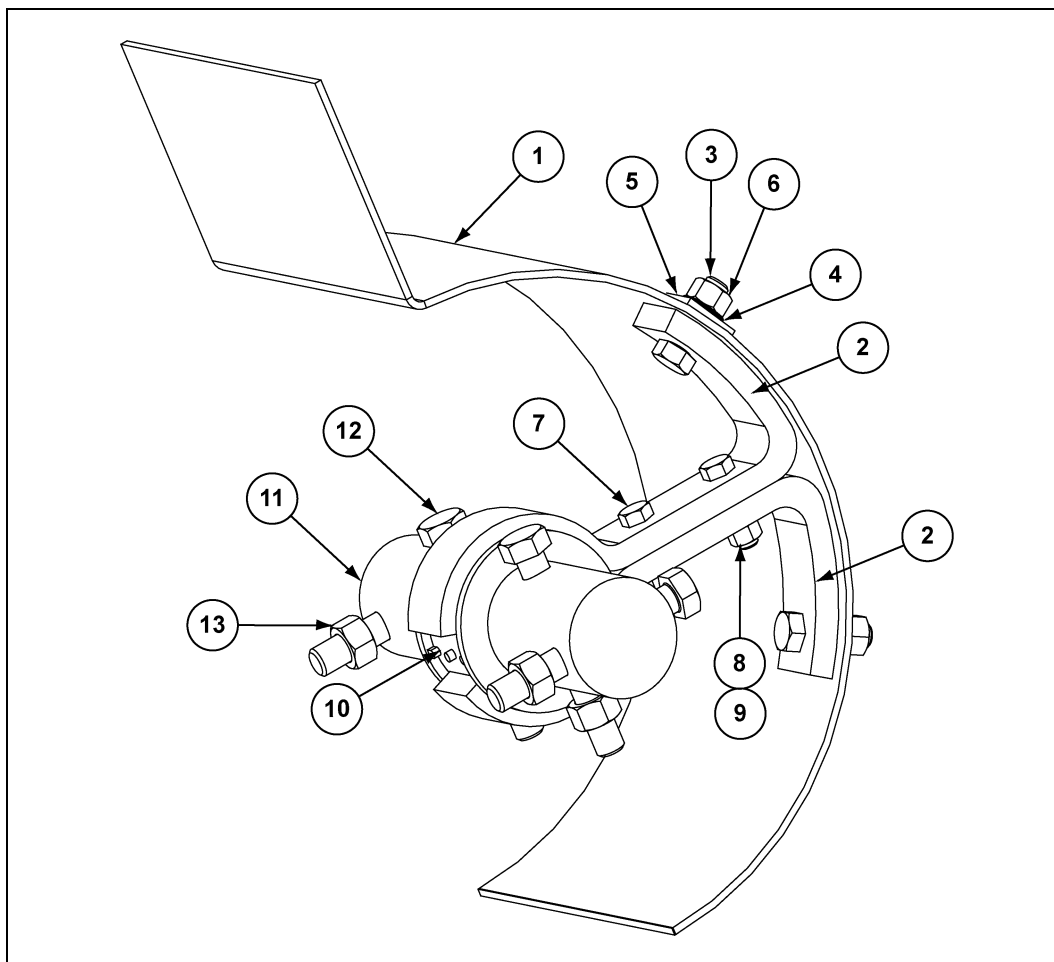

Ref #	Part #	Description	Qty Per Connection
1		Intermediate Shroud - 3/16" x 16"	N/A
2	GC04064	Hanger Bearing Bracket for 16" Sweep	2
3	S-4329	Bolt, HHCS 5/8"-11 x 2" ZN Grade 8	2
4	S-3208	5/8" Lock Washer	2
5	S-8423	Washer, Flat SQ 11/16" ZN	2
6	S-4110	Nut, Hex 5/8"-11 ZN Grade 5	2
7	S-7811	Bolt, HHCS 1/2"-13 x 2" ZN	2
8	S-236	1/2" Lock Washer	2
9	S-3729	Nut, Hex 1/2"-13 ZN YDP Grade 5	2
10	GC07702	Nylon Bearing: 3"	2
11	GC03559	3" Coupling Stub	1
12	S-6638	Bolt, HHCS 3/4"-10 x 5-1/2" ZN Grade 8	4
13	S-6639	Nut, Hex 3/4"-10 ZN Grade 5	4

End Bearing Components

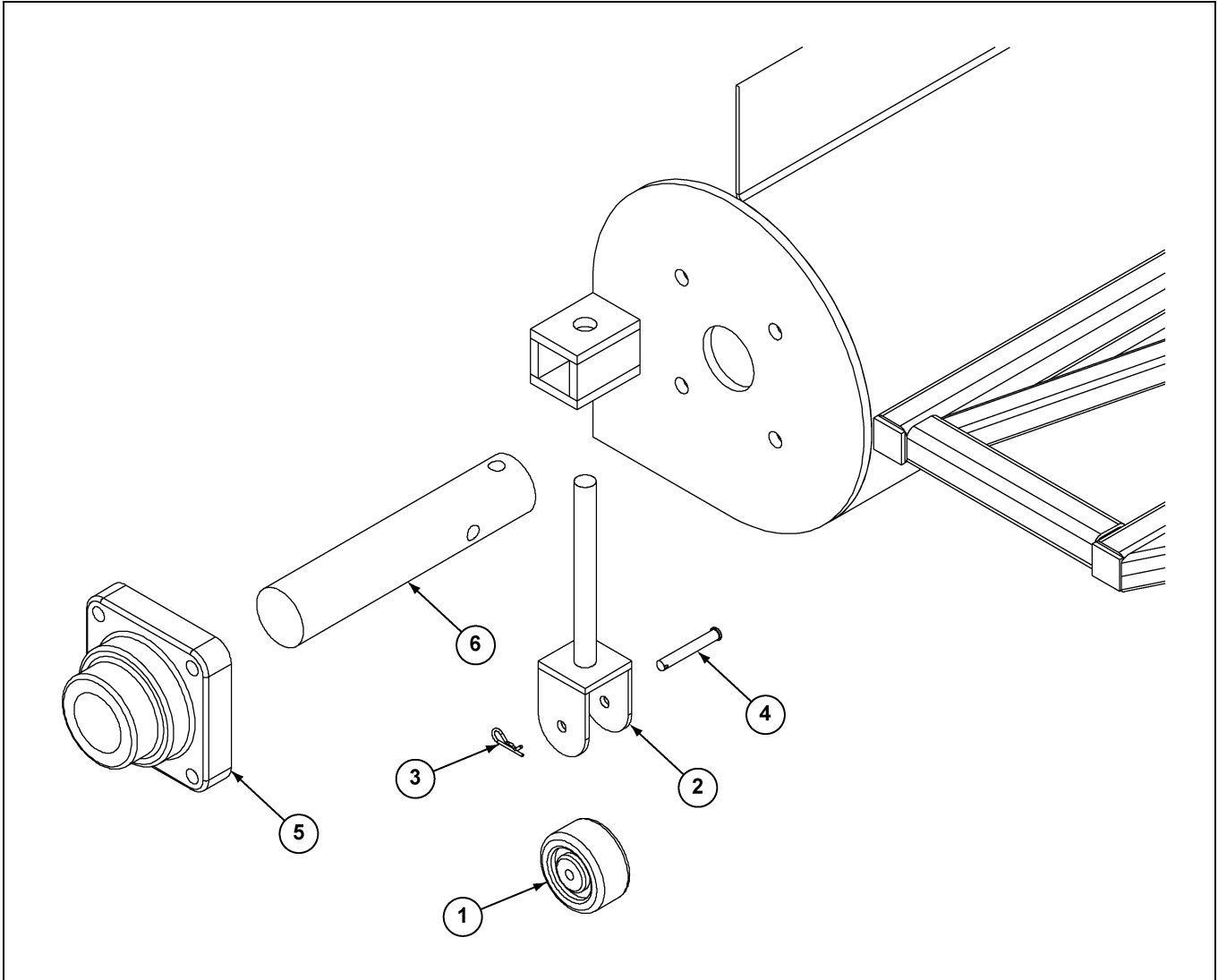

Ref #	Part #	Description
1	GC03385	Caster 2" x 4" x 1/2" Axle (16" Sweeps)
2	GC03480	End Caster Assembly (16" Sweeps)
3	GC03387	Hairpin, 1-15/16" x 0.125" Wire (16" Sweeps)
4	GK1522	Washer Head Pin 1/2" Dia. x 3-1/2" (16" Sweeps)
5	KD-PBA0004	Flange Bearing 2" End Cap (12" Sweeps)
	GC03577	Flange Bearing 3" End Cap (16" Sweeps)
6	GC03957	End Stub 2" x 12" (12" Sweeps)
	GC03556	End Stub 3" x 14-7/8" (16" Sweeps)

NOTES



Auger Drive Components

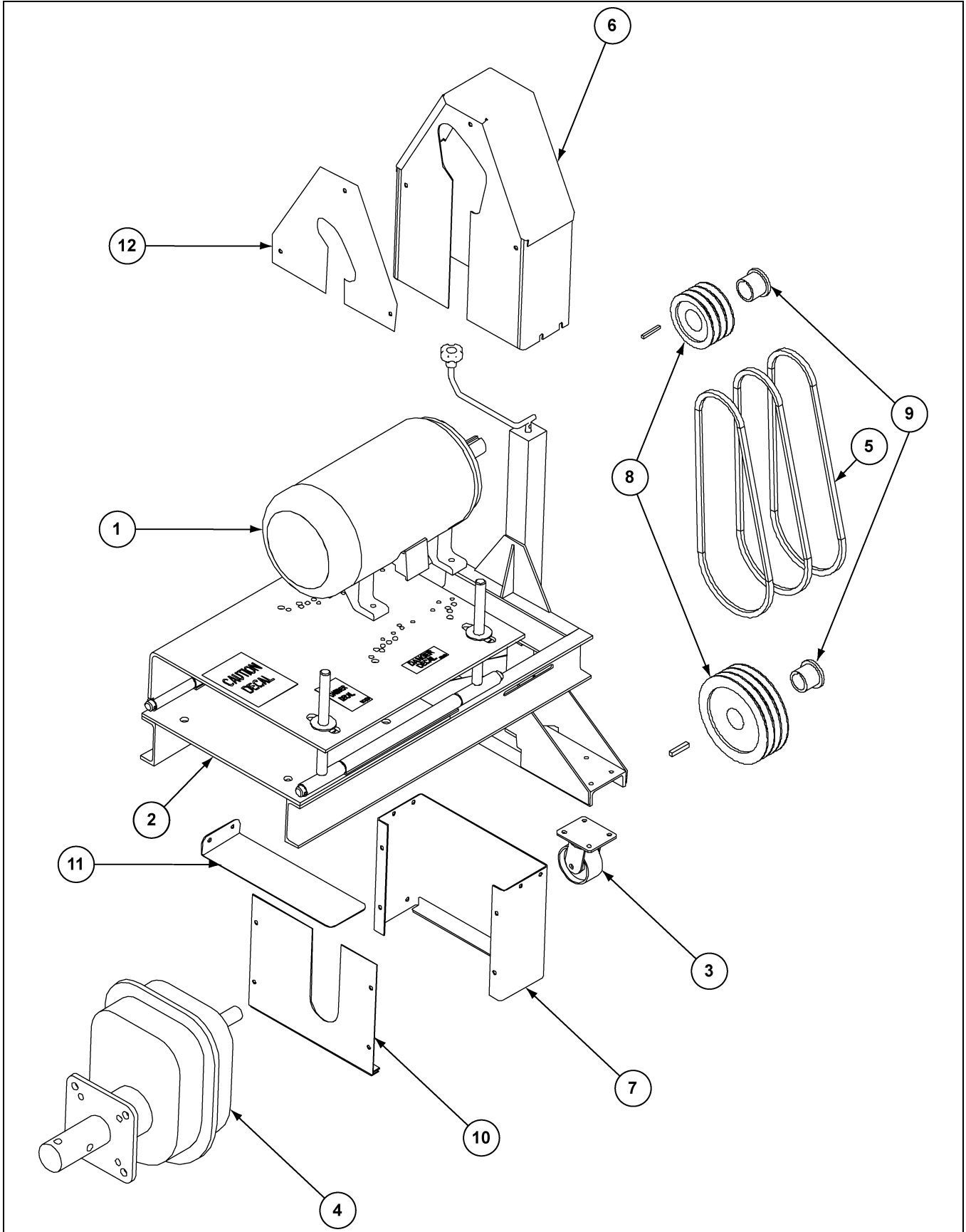

Auger Drive Components Parts List

Ref #	Part #	Description
1	N/A	Motor: XPFC, Class 2 Group F and G
	712-3-XP	7.5 HP - 213T Frame
	MHC60010X	10 HP - 215T Frame
	MHC60015X	15 HP - 254T Frame
	MHC60020X	20 HP - 256T Frame
	MHC60025X	25 HP - 284T Frame
2	GC09993	Motor Mount Assembly w/Jack
	GC09986	Motor Mount Base Assembly
	GC09992	Motor Jack Assembly
3	GC03436	Swivel Caster 1-1/2" x 4"
4	N/A	Reducer: w/CEMA Adapter and Output Shaft
	GC11363	115SMTP05-2"
	GC09809	115SMTP09-2"
	GC11364	203SMTP05-2"
	GC09587	203SMTP09-2"
	GC11597	207SMTP09-2"
	GC09810	115SMTP09-3"
	GC09588	203SMTP09-3"
	GC09589	207SMTP09-3"
GC09591	215SMTP09-3"	
5	N/A	Belt BX Style
6	GC09770	Belt Guard Assembly, Top
7	GC09764	Belt Guard Assembly, Bottom
8	N/A	Sheave
9	N/A	QD Bushing
N/S	GC03654	Motor Cover 39" x 35" x 20"
10	GC09762	Belt Guard Bottom Back Plate
11	GC09759	Belt Guard Bottom Pan
12	N/A	Belt Guard Motor Specific Plate
	GC09875	184T Frame
	GC09876	213/215T Frames
	GC09877	254/256T Frames
	GC09878	284/286T Frames
	GC09879	324T Frame

NOTE: Owners and installers of 7000 bushel per hour Series II Sweeps using 230/460/575 Volt, 60 Hertz power should note that the belt drive for a 7000 bushel per hour sweep uses a special "Speed Up" style belt and sheave arrangement. The drive sheave is larger than the driven sheave. In almost all cases the drive sheave is a 7.15" outside diameter (6.8" P.D.) with the driven sheave a 6.3" outside diameter (6" P.D.).

Drive Assembly

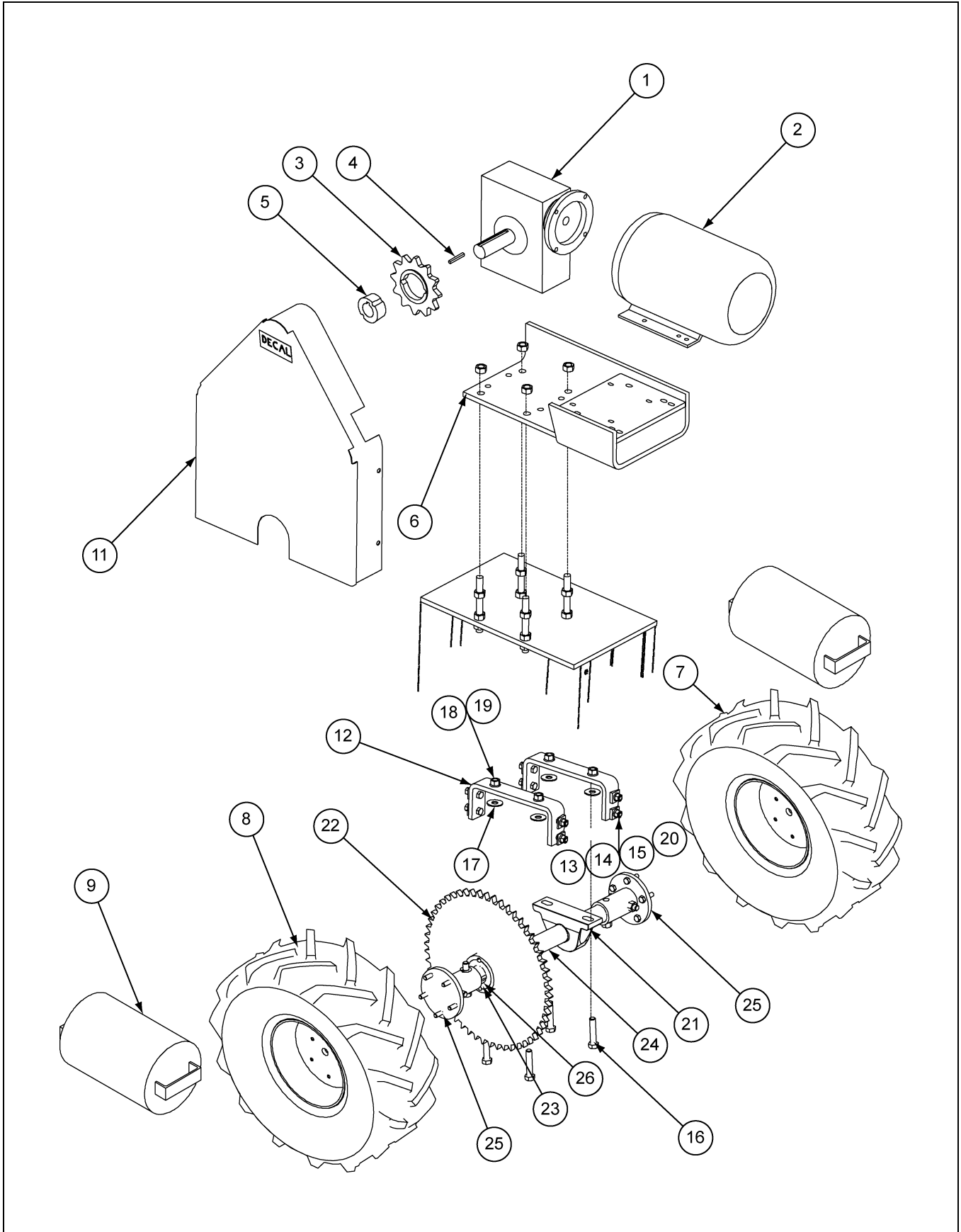

Drive Assembly Parts List

Ref #	Part #	Description	Qty
1	GK80065	10-2009 to Present - Reducer, 324 Model, 40:1 Style B, 56C Frame (Used with 1 HP Motors, 56C Frame)	1
	GC06631	Up to 10-2009	
	GK80066	10-2009 to Present - Reducer, 384 Model, 40:1 Style B, 143TC Frame (Used with 2 HP Motors, 143TC Frame)	
	GC03651	Up to 10-2009	
	GK80067	10-2009 to Present - Reducer, 384 Model, 40:1 Style B, 182TC Frame (Used with 3 HP Motors, 182TC Frame)	
	GC06477	Up to 10-2009	
2	GC09775	Motor: XPFC, Class 2 Group F and G, 1 HP 1760 RPM 460/3/60 56C Frame w/ Feet	1
	GC09743	Motor: XPFC, Class 2 Group F and G, 2 HP 1760 RPM 460/3/60 143TC Frame w/ Feet	1
	GC09776	Motor: XPFC, Class 2 Group F and G, 3 HP 1760 RPM 460/3/60 182TC Frame w/ Feet	1
	GC09932	Motor: XPFC, Class 2 Group F and G, 5 HP 1760 RPM 460/3/60 184TC Frame w/ Feet (380V Only)	1
3	GC07467	Sprocket, #80 12 Tooth	1
4	GC04494	Key, Square 3/8" x 3" (for Model 384 Reducer)	1
	S-8430	Key, Square 5/16" x 2" (for Model 324 Reducer)	1
5	GC07468	Bushing, 1615 x 1-3/8" Bore Taper Lock	1
	GC07469	Bushing, 1615 x 1-1/2" Bore Taper Lock	1
6	GC09827	324 Reducer Mount Plate (for 1 HP Motor)	1
	GC09670	384 Reducer Mount Plate (for 2 HP Motor)	1
	GC09661	384 Reducer Mount Plate (for 3 and 5 HP Motors)	1
7	GC03476	Tire, Mounted, 12-8 x 23" Right Hand Tractor Tread-Foam Filled	1
8	GC06508	Tire, Mounted, 12-8 x 23" Left Hand Tractor Tread-Foam Filled	1
9	GC03490	175 Lbs. Counterweight	
N/S	GC10195	Drive Axle Assembly - Bolt on Hubs (Not Shown)	1
11	GC10044	Top Chain Guard Assembly	1
12	GC09899	Bearing Support Bracket	2
13	S-3883	Bolt, HHCS 1/2"-13 x 1-3/4"	8
14	S-236	Washer, Lock Split 1/2"	8
15	S-3729	Nut, Hex 1/2"-13	8
16	S-8429	Bolt, HHCS 5/8"-11 x 2-1/2"	4
17	S-858	Washer, Flat 5/8"	4
18	S-3208	Washer, Lock Split 5/8"	4
19	S-4110	Nut, Hex 5/8"-11	4
20	S-9242	5/8" Beveled Washer	4
21	GC03475	Bearing, Pillow Block 2" ID	2
22	GC03681	Sprocket #80 54 Tooth for Axle	1
23	GC03682	Bushing, 2" #2517 Taper Lock	1
24	GC08849	Bolt-on Drive Axle	1
25	GC09505	Bolt-on Hub Assembly	2
26	GC03811	Key, Square 1/2" x 2-1/4"	1
N/S	GC06866	Roller Chain #80 x 71"	1
N/S	GC03684	Connecting Link #80	1
N/S	GC03685	Offset Link #80	1
N/S	GC03653	Motor Cover 57" x 35" x 20"	1

Tractor Chain Guard Parts

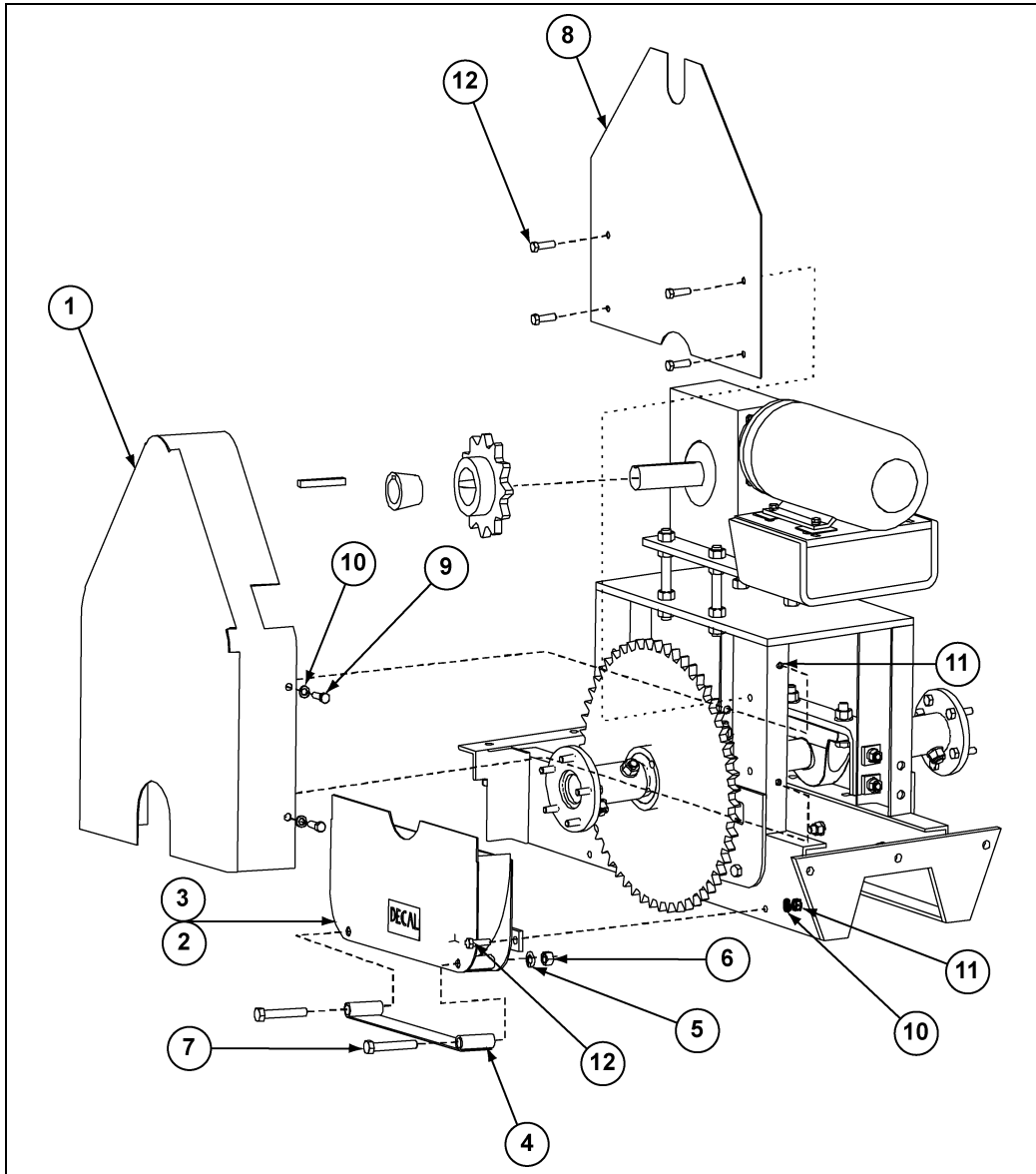

Ref #	Parts #	Description	Qty
1	GC10044	Top Chain Guard Assembly	1
2	GC10048	Bottom Chain Guard Assembly	1
3	GC10036	Bottom Chain Guard Weldment	1
4	GC10047	Bottom Chain Guard Trap	1
5	S-236	Washer, Split Lock 1/2"	2
6	S-3729	Nut, Hex 1/2"-13	2
7	S-7722	Bolt, 1/2"-13 x 3"	2
8	GC10035	Guard Plate	1
9	S-7469	Bolt, HHCS 3/8"-16 x 1"	4
10	S-1054	Washer, Lock Split 3/8"	10
11	S-456	Nut, Hex 3/8"-16	10
12	S-2071	Bolt, HHCS 3/8"-16 x 1-1/4"	6

Motor Mount Jack and Base Assembly (GC09993)

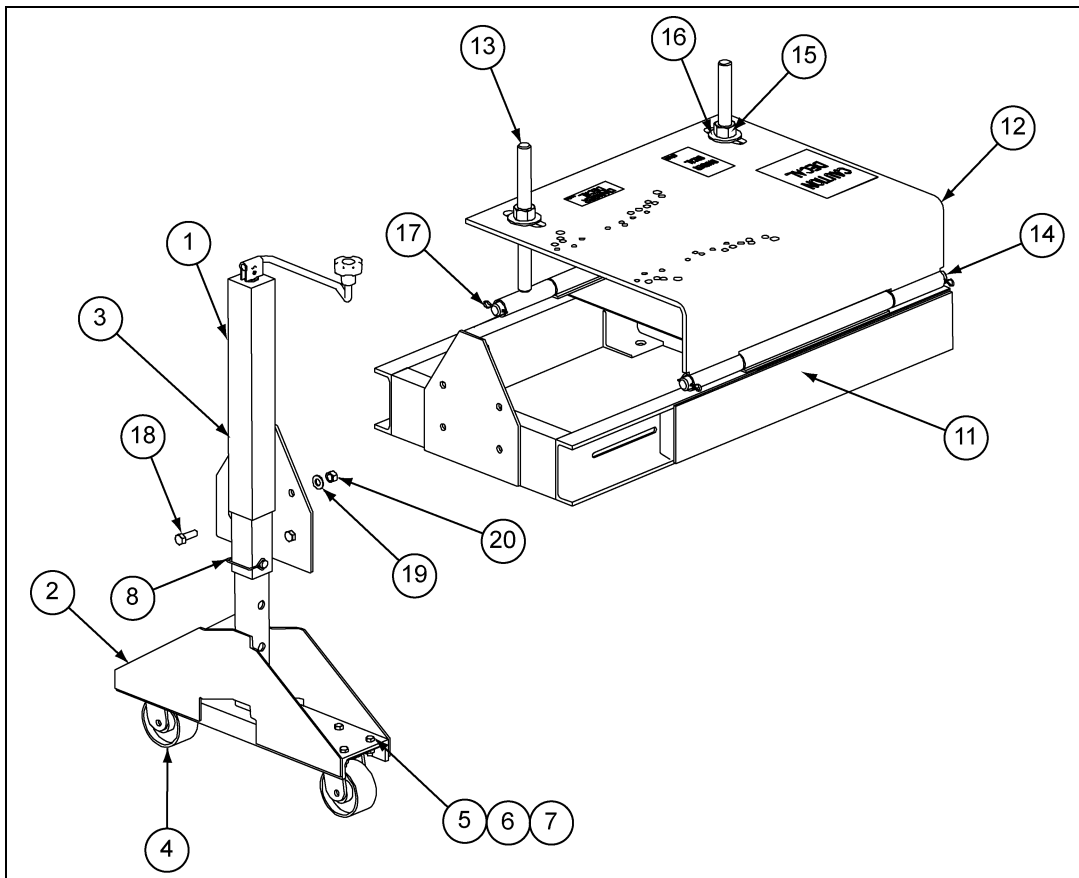

Motor Jack Assembly (GC09992)

Ref #	Part #	Description	Qty
1	GC09991	Jack Housing Assembly	1
2	GC09479	Jack/Caster Mount Base	1
3	GC10461	Jack-w/o Outer Housing	1
4	GC03436	Swivel Caster	2
5	S-1054	Washer, Lock 3/8"	8
6	S-2071	Bolt, 3/8"-16 x 1-1/4"	8
7	S-456	Nut, Hex 3/8"-16	8
8	S-8441	Jack Clevis Pin	1

Motor Mount Base Assembly (GC09986)

Ref #	Part #	Description	Qty
11	GC09984	Frame Weldment	1
12	GC09756	Top Plate Assembly	1
13	GC09755	Adjuster Assembly	2
14	GC09757	Pivot Shaft	2
15	S-240	Nut, Hex 1"-8	4
16	S-7835	Washer, Flat 1"	4
17	S-7241	Cotter Pin 1/8" x 1-1/4"	4
18	S-8760	Bolt, 1/2"-13 x 1-1/2"	4
19	S-2120	Washer, Flat 1/2"	4
20	S-3729	Nut, Hex 1/2"-13	4

All 12" Sweep Jack Supports and 16" Jack Supports after 11-01-04

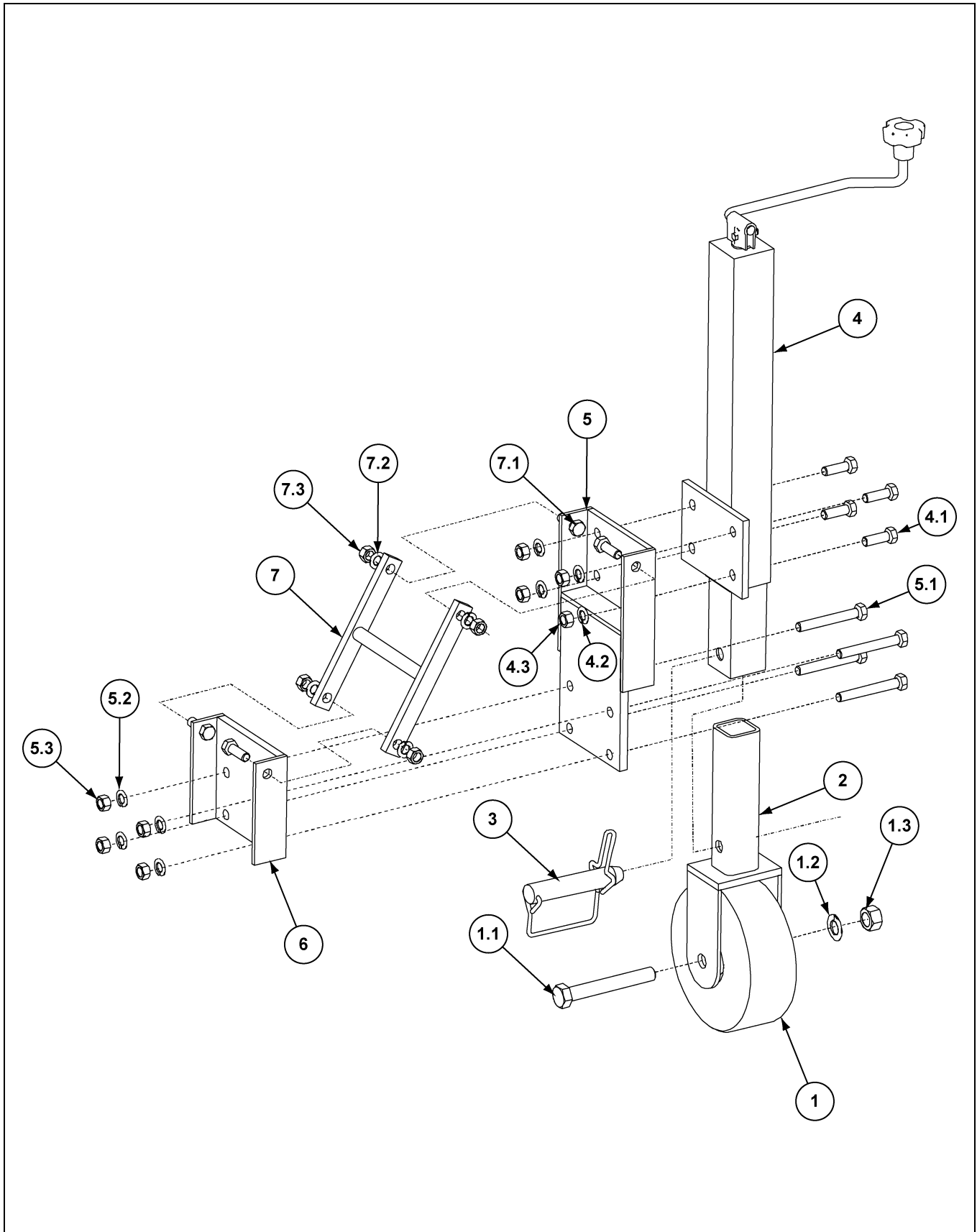

All 12" Sweep Jack Supports and 16" Jack Supports after 11-01-04 Parts List

Ref #	Part #	Description	Qty
1	GC06974	Caster Wheel 3" x 8" Dia. x 3/4" Axle	1
1.1	S-6638	Bolt, HHCS 3/4"-10 x 5-1/2" ZN Grade 8	1
1.2	S-233	Washer, Lock Split 3/4" ZN	1
1.3	S-234	Nut, Hex 3/4"-10 ZN Grade 5	1
2	GC08507	S2 Sweep Jack Caster Assembly - 12"	1
3	S-8441	Pin	1
4	GC07934	S2 Sweep 7000# Jack Assembly	1
4.1	S-7528	Bolt, HHCS 1/2"-13 x 1-1/2" ZN Grade 5	4
4.2	S-236	Washer, Lock Split 1/2" ZN	4
4.3	S-7510	Nut, Hex 1/2"-13 ZN Grade 5	4
5	GC07839	Jack Mount Assembly	1
5.1	S-8400	Bolt, HHCS 1/2"-13 x 3-3/4" ZN Grade 5	4
5.2	S-236	Washer, Lock Split 1/2" ZN	4
5.3	S-7510	Nut, Hex 1/2"-13 ZN Grade 5	4
6	GC07926	S2 Sweep Jack Mount Plate Assembly	1
7	GC07931	S2 Sweep Jack Truss Assembly - 16"	1
7.1	S-7528	Bolt, HHCS 1/2"-13 x 1-1/2" ZN Grade 5	4
7.2	S-236	Washer, Lock Split 1/2" ZN	4
7.3	S-7510	Nut, Hex 1/2"-13 ZN Grade 5	4
N/S	GC08627	BOP: Jack Kit 12" (Contains all above parts less wheel)	1

Old Style 16" Sweep Jack Support (Before 11-01-04)

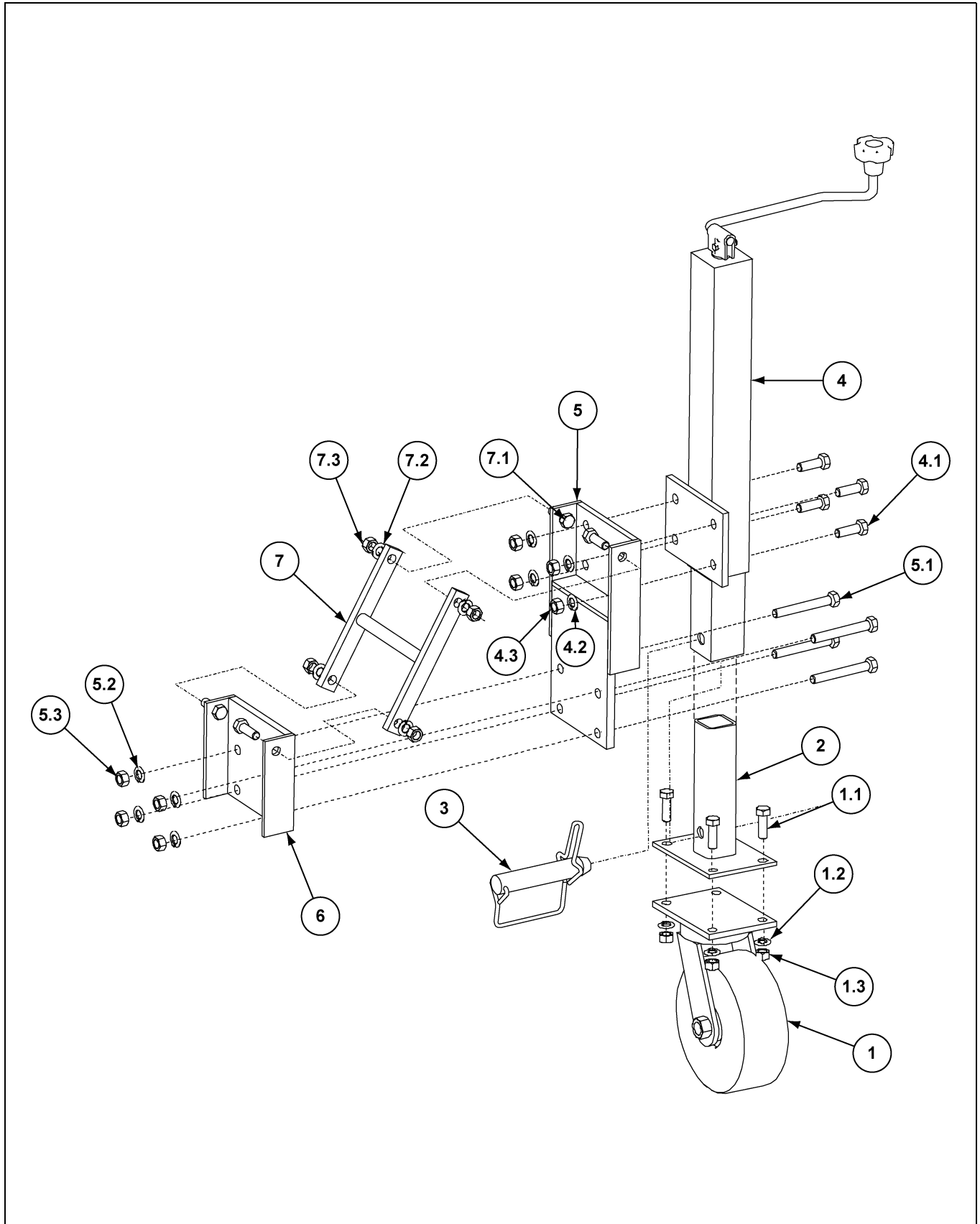

Old Style 16" Sweep Jack Support (Before 11-01-04) Parts List

Ref #	Part #	Description	Qty
1	GC07904	Swivel Caster 3" x 8" Dia.	1
1.1	S-7528	Bolt, HHCS 1/2"-13 x 1-1/2" ZN Grade 5	4
1.2	S-236	Washer, Lock Split 1/2" ZN	4
1.3	S-7510	Nut, Hex 1/2"-13 ZN Grade 5	4
2	GC07908	S2 Sweep Jack Caster Assembly - 16"	1
3	S-8441	Pin	1
4	GC07934	S2 Sweep 7000# Jack Assembly	1
4.1	S-7528	Bolt, HHCS 1/2"-13 x 1-1/2" ZN Grade 5	4
4.2	S-236	Washer, Lock Split 1/2" ZN	4
4.3	S-7510	Nut, Hex 1/2"-13 ZN Grade 5	4
5	GC07839	Jack Mount Assembly	1
5.1	S-8400	Bolt, HHCS 1/2"-13 x 3-3/4" ZN Grade 5	4
5.2	S-236	Washer, Lock Split 1/2" ZN	4
5.3	S-7510	Nut, Hex 1/2"-13 ZN Grade 5	4
6	GC07926	S2 Sweep Jack Mount Plate Assembly	1
7	GC07931	S2 Sweep Jack Truss Assembly - 16"	1
7.1	S-7528	Bolt, HHCS 1/2"-13 x 1-1/2" ZN Grade 5	4
7.2	S-236	Washer, Lock Split 1/2" ZN	4
7.3	S-7510	Nut, Hex 1/2"-13 ZN Grade 5	4
N/S	GC07993	BOP: Jack Kit 16" (Contains all above parts)	1

Control Panel Components Pre-June 2010

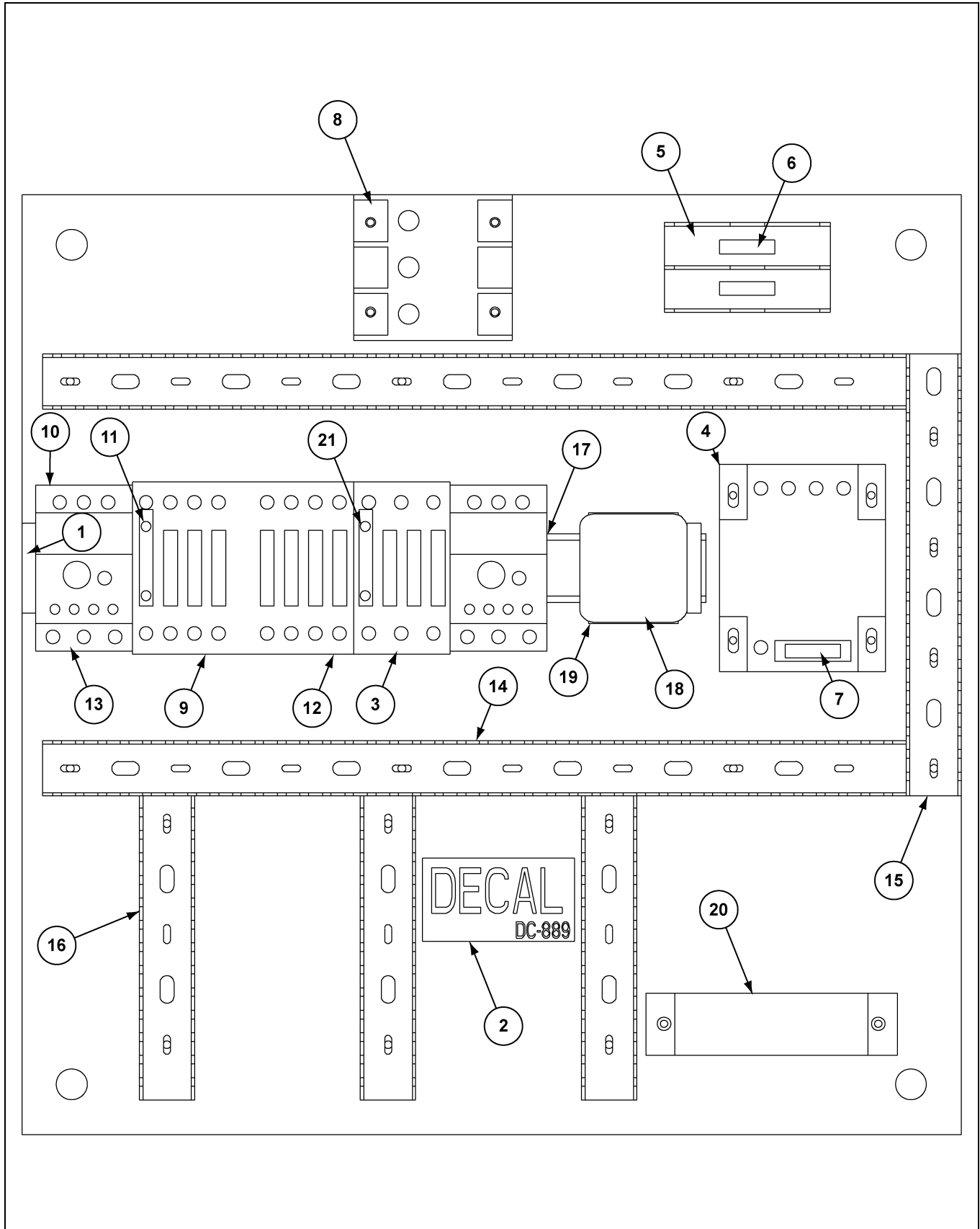

Control Panel Components Pre-June 2010 Parts List

Ref #	Part #	Description
1	D01-0533	Din Rail End Stop
2	DC-889	Decal, DANGER! High Voltage
3	D03-0491	Starter 3 Pole Cont 22 Amps
	D03-0492	Starter 3 Pole Cont 32 Amps
	D03-0494	Starter 3 Pole Cont 48 Amps
	D03-0495	Starter 3 Pole Cont 62 Amps
	D03-0498	Starter 3 Pole Cont 96 Amps
4	GC03673	Transformer, 50 VA 50/60 Hz, 230/380/460
	GC07950	Transformer, 50 VA 50 Hz, 380V
	GC09386	Transformer, 50 VA 60 Hz, 200/120V
	GC09509	Transformer, 50 VA 50 Hz, 415V
5	GC03676	Fuse Block 2 Pole
6	GC03677	Fuse, 600V Midget TD 1/4 Amp
7	GC03679	Fuse, 250V Midget TD 6/10 Amp
8	C-8018	3 Pole Power Distribution Block
9	GC06951	Contact 5 HP Reversing 120V 60 Hz Coil
10	GC06953	Panel Mount for Overloads
11	GC06967	Contact Block 1 Pole N.C.
12	D03-0475	IEC O/L Relay 10.0-16.0 Amps
	D03-0477	IEC O/L Relay 17.5-22.0 Amps
	GC07862	IEC O/L Relay 21.0-26.0 Amps
	D03-0479	IEC O/L Relay 25.0-32.0 Amps
	D03-0482	IEC O/L Relay 30.0-43.0 Amps
	D03-0483	IEC O/L Relay 42.0-55.0 Amps
	D03-0485	IEC O/L Relay 64.0-82.0 Amps
13	D03-0543	IEC O/L Relay 1.8-2.7 Amps
	D03-0471	IEC O/L Relay 2.5-4.1 Amps
	D03-0472	IEC O/L Relay 4.0-6.3 Amps
	GC07795	IEC O/L Relay 5.5-8.5 Amps
14	E160-1178	Wire Duct 1" x 2" x 15-5/8"
15	E160-1178	Wire Duct 1" x 2" x 8"
16	E160-1178	Wire Duct 1" x 2" x 5-1/2"
17	GC06993	Din Rail 12-3/8"
18	GC07509	AC Current Transducer
19	GC07510	AC Current Transducer Socket
20	GC07511	Current Transformer 50:5 Amp
	GC09250	Current Transformer 75:5 Amp
21	GC07591	Contact Block 1 Pole N.O.

Control Panel Components Pre-June 2010 (Continued)

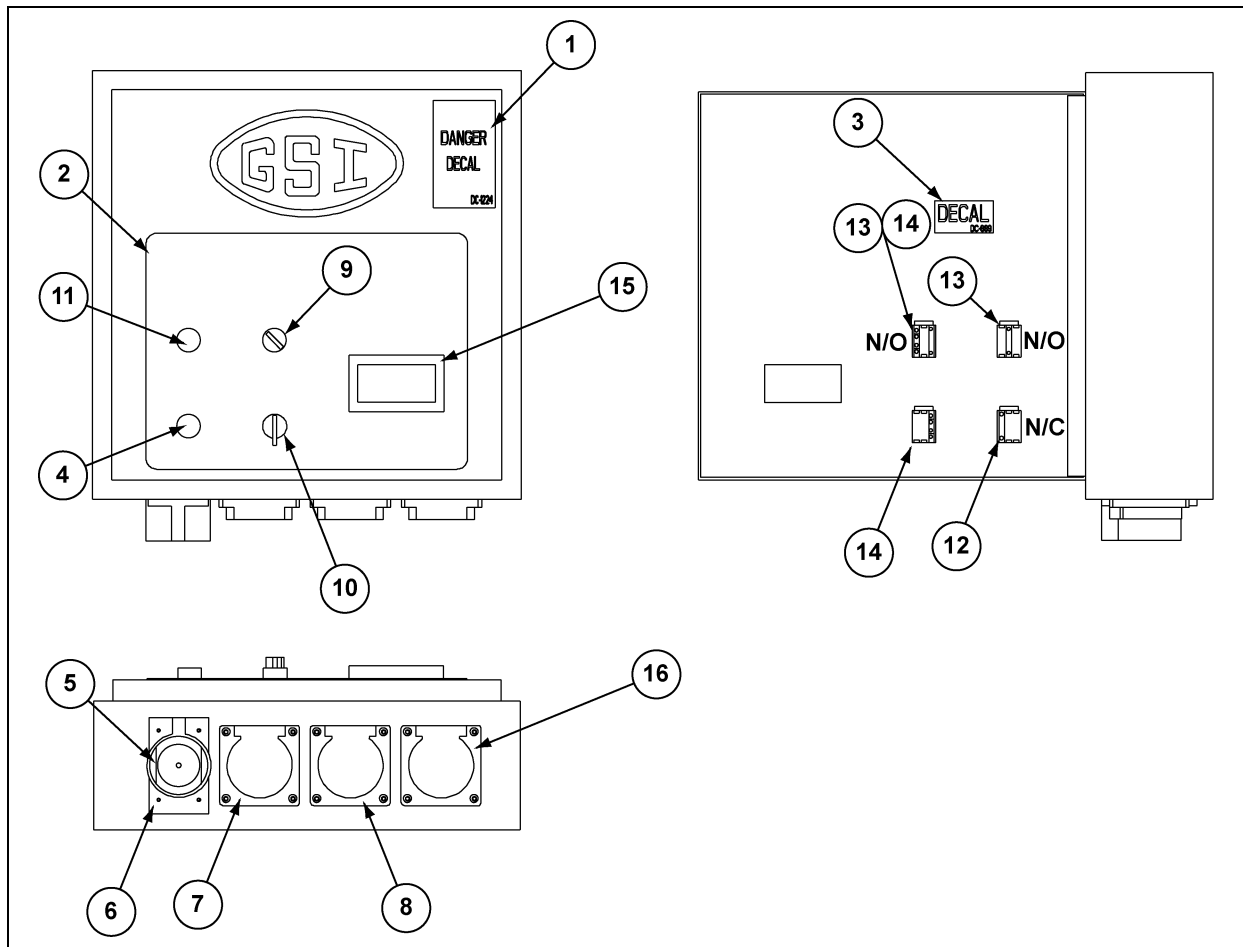

Ref #	Part #	Description
1	DC-1224	Decal, Danger High Voltage
2	DC-1536	Decal, Series II Sweep Panel Overlay
3	DC-889	Decal, Danger High Voltage
4	GC03659	Std-Round-Push Button-Plastic-Flush-Red
5	GC03666	Hubbell Locking Receptacle - 3 Pole 4-Wire 50 Amps 480 Voltage
6	GC03667	Hubbell Wdl Open Lift Cover
N/S	GC03668	Hubbell Locking Plug - 3 Pole 4-Wire 50 Amps 480 Voltage
7	GC03669	Hubbell Locking Receptacle - Nema L16-20R
N/S	GC03670	Hubbell Locking Plug - Nema L16-20P
8	GC06954	Hubbell Locking Receptacle - Nema L7-20R
9	GC06956	2 Position - Maint - Plastic - Black
10	GC06957	3 Position - Lever - SL - Sw - Momentary
11	GC06958	Std-Round-Push Button-Plastic-Flush-Green
12	D63-0013	Cnt Blck/1 N.C./SCR
13	D63-0006	Cnt Blck/1 N.O./SCR
14	GC06961	Cnt Blck/SCR
15	GC07585	Series II Sweep Amp Meter
16	GC03671	Hubbell Locking Receptacle - Nema L5-20R
N/S	GC03672	Hubbell Locking Plug - Nema L5-20P
N/S	GC06857	Series II Sweep Safety Foot Switch Assembly

Weight Extension Kit (GC08144)

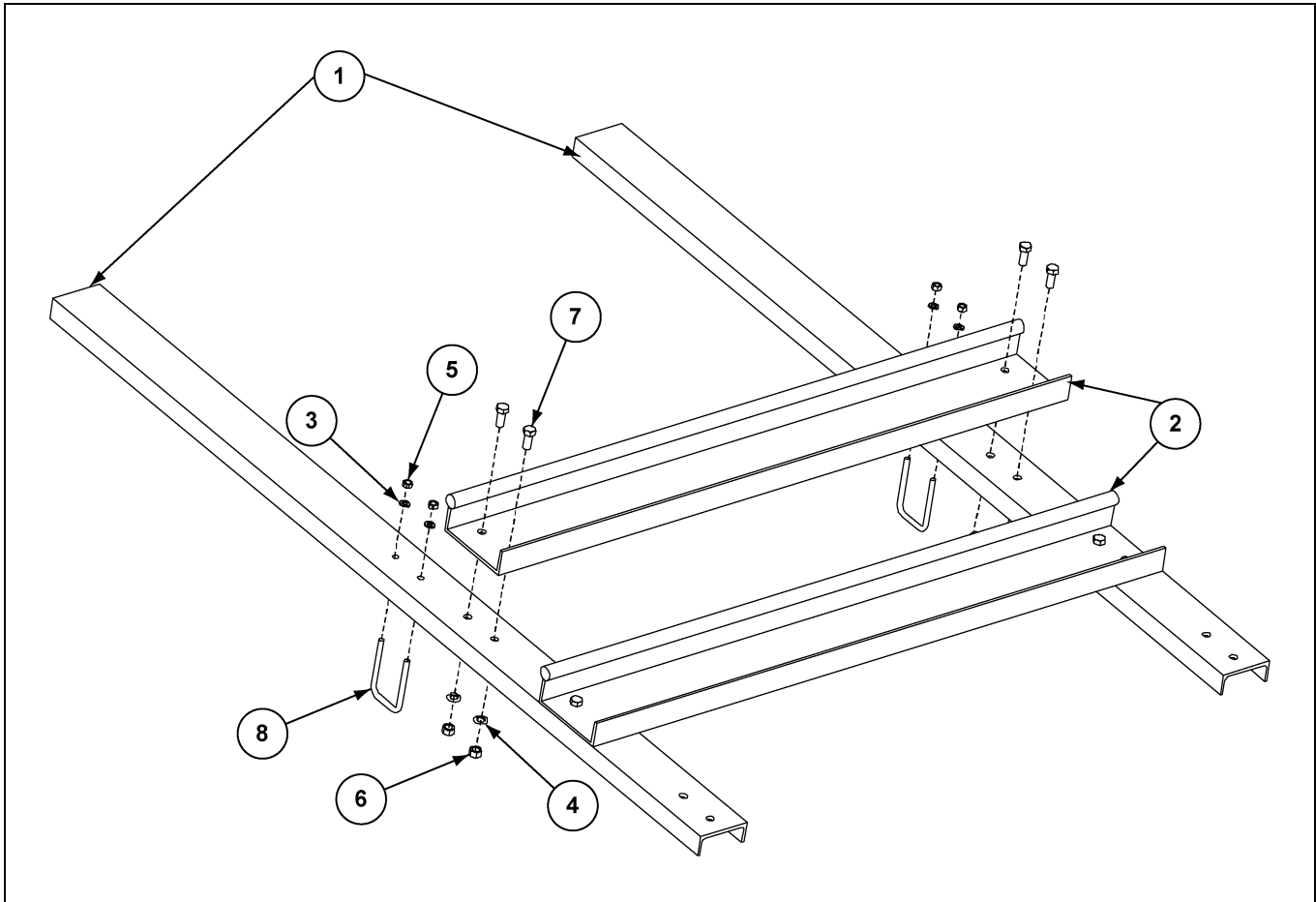

Weight Channel Kit Parts List

Ref #	Part #	Description
1	GC08141	S2 Sweep Adjustable Center Weight Channel
2	GC08143	S2 Sweep Center Weight Channel Weldment
3	S-1054	3/8" Split Lock Washer Zinc
4	S-236	1/2" Split Lock Washer Med Zinc
5	S-456	3/8"-16 Hex Nut Zinc YDP Grade 5
6	S-7510	1/2"-13 Hex Nut Zinc Grade 2
7	S-7534	1/2"-13 x 1-1/4" HHCS Bolt Zinc Grade 5
8	S-8666	3/8"-16 x 2-7/16" U-Bolt Zinc
N/S	GC03490	Solid Type Counterweight (Before April 2008)
N/S	GC12208	Counterweight Long Version (After April 2008)

Components

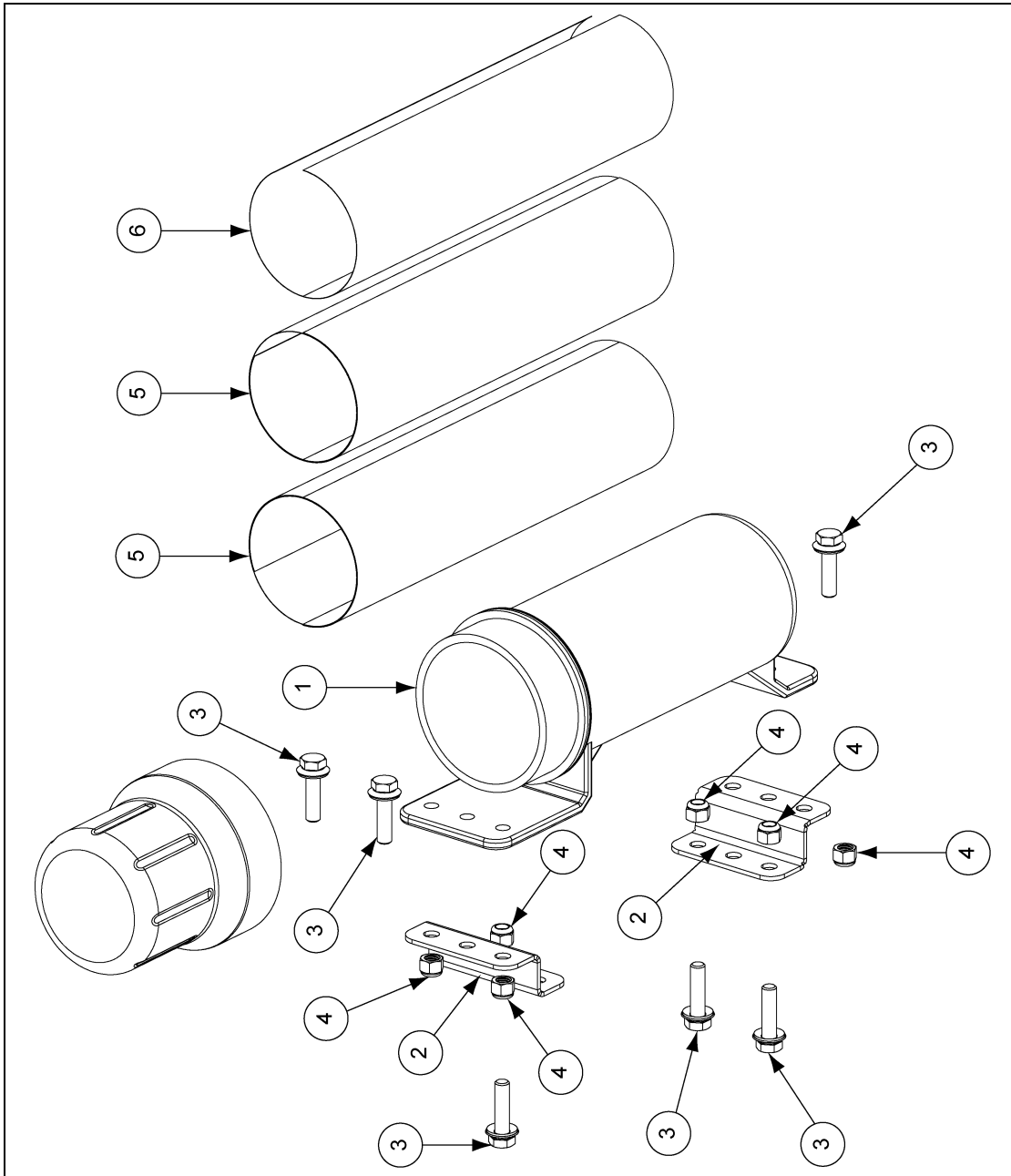

Components Parts List

Ref #	Part #	Description	Qty
N/S	GK80047	Quick Start Guide Complete Assembly	N/A
1	GK80046	Manual Canister Assembly	1
2	GK80045	Canister Bracket	1
3	S-277	5/16"-18 x 1-1/4" HH Bin Bolt w/ Washer YDP Grade 5	6
4	S-7382	5/16"-18 Nylock Nut Zinc Grade 5	6
5	PNEG-1723	Series II Sweep Quick Start Guide Pre-June 2010	0
5	PNEG-1759	Series II Sweep Quick Start Guide Post-May 2010	2
6	PNEG-1724	Quick Start Guide Installation Manual	1

GSI Group, LLC Limited Warranty

The GSI Group, LLC ("GSI") warrants products which it manufactures to be free of defects in materials and workmanship under normal usage and conditions for a period of 12 months after sale to the original end-user or if a foreign sale, 14 months from arrival at port of discharge, whichever is earlier. The end-user's sole remedy (and GSI's only obligation) is to repair or replace, at GSI's option and expense, products that in GSI's judgment, contain a material defect in materials or workmanship. Expenses incurred by or on behalf of the end-user without prior written authorization from the GSI Warranty Group shall be the sole responsibility of the end-user.

Warranty Extensions:

The Limited Warranty period is extended for the following products:

	Product	Warranty Period	
AP Fans and Flooring	Performer Series Direct Drive Fan Motor	3 Years	* Warranty prorated from list price: 0 to 3 years - no cost to end-user 3 to 5 years - end-user pays 25% 5 to 7 years - end-user pays 50% 7 to 10 years - end-user pays 75%
	All Fiberglass Housings	Lifetime	
	All Fiberglass Propellers	Lifetime	
Cumberland Feeding/Watering Systems	Feeder System Pan Assemblies	5 Years **	** Warranty prorated from list price: 0 to 3 years - no cost to end-user 3 to 5 years - end-user pays 50%
	Feed Tubes (1-3/4" and 2.00")	10 Years *	
	Centerless Augers	10 Years *	
	Watering Nipples	10 Years *	
Grain Systems	Grain Bin Structural Design	5 Years	† Motors, burner components and moving parts not included. Portable dryer screens included. Tower dryer screens not included.
Grain Systems Farm Fans Zimmerman	Portable and Tower Dryers	2 Years	
	Portable and Tower Dryer Frames and Internal Infrastructure †	5 Years	

GSI further warrants that the portable and tower dryer frame and basket, excluding all auger and auger drive components, shall be free from defects in materials for a period of time beginning on the twelfth (12th) month from the date of purchase and continuing until the sixtieth (60th) month from the date of purchase (extended warranty period). During the extended warranty period, GSI will replace the frame or basket components that prove to be defective under normal conditions of use without charge, excluding the labor, transportation, and/or shipping costs incurred in the performance of this extended warranty.

Conditions and Limitations:

THERE ARE NO WARRANTIES THAT EXTEND BEYOND THE LIMITED WARRANTY DESCRIPTION SET FORTH ABOVE. SPECIFICALLY, GSI MAKES NO FURTHER WARRANTY OF ANY KIND, EXPRESS OR IMPLIED, INCLUDING, WITHOUT LIMITATION, WARRANTIES OF MERCHANTABILITY OR FITNESS FOR A PARTICULAR PURPOSE OR USE IN CONNECTION WITH: (I) PRODUCT MANUFACTURED OR SOLD BY GSI OR (II) ANY ADVICE, INSTRUCTION, RECOMMENDATION OR SUGGESTION PROVIDED BY AN AGENT, REPRESENTATIVE OR EMPLOYEE OF GSI REGARDING OR RELATED TO THE CONFIGURATION, INSTALLATION, LAYOUT, SUITABILITY FOR A PARTICULAR PURPOSE, OR DESIGN OF SUCH PRODUCTS.

GSI shall not be liable for any direct, indirect, incidental or consequential damages, including, without limitation, loss of anticipated profits or benefits. The sole and exclusive remedy is set forth in the Limited Warranty, which shall not exceed the amount paid for the product purchased. This warranty is not transferable and applies only to the original end-user. GSI shall have no obligation or responsibility for any representations or warranties made by or on behalf of any dealer, agent or distributor.

GSI assumes no responsibility for claims resulting from construction defects or unauthorized modifications to products which it manufactured. Modifications to products not specifically delineated in the manual accompanying the equipment at initial sale will void the Limited Warranty.

This Limited Warranty shall not extend to products or parts which have been damaged by negligent use, misuse, alteration, accident or which have been improperly/inadequately maintained. This Limited Warranty extends solely to products manufactured by GSI.

Prior to installation, the end-user has the responsibility to comply with federal, state and local codes which apply to the location and installation of products manufactured or sold by GSI.

This equipment shall be installed in accordance with the current installation codes and applicable regulations which should be carefully followed in all cases. Authorities having jurisdiction should be consulted before installations are made.

G S I G R O U P



**GSI Group
1004 E. Illinois St.
Assumption, IL 62510-0020
Phone: 1-217-226-4421
Fax: 1-217-226-4420
www.gsiag.com**