

12" Series II Sweep 131' and 135' Diameter

Owner's Manual

PNEG-751-G2

Date: 07-21-10

GSI GROUP



PNEG-751-G2

Model Number of My Sweep:

Date Delivered:

Date Installed:

NOTE: *The manufacturer reserves the right to improve its product whenever possible and practical to do so. We reserve the right to change, improve and modify products at any time without obligation to make changes, improvements and modifications on equipment sold previously.*

Personnel operating or working around this equipment should read this manual. This manual must be delivered with equipment to its owner. Failure to read this manual and its safety instructions is a misuse of the equipment. Any misuse of the equipment may void the warranty.

Contents

Chapter 1 Introduction	5
Product Introduction	5
Chapter 2 Safety	7
Safety Guidelines	7
Safety Instructions	8
Operator Qualifications	12
Chapter 3 Safety Decals	13
Chapter 4 General Product Information	17
Product Information	17
General Information	17
Capacities and Specifications	18
Q-D Bushings - Reverse Mounting	21
Chapter 5 Assembly	23
Back Shield Assembly	23
Flighting Assembly	24
Hanger Bracket Assembly	25
Flange Bearing Assembly	26
Gear Reducer Assembly	26
Drive Axle Assembly and Bearing Support	27
Install Reducer Mounting Plate and Reducer	29
Key Alignment	30
Install Tractor Drive Motor	31
Guard Assembly	32
Tractor Wheel Assembly	34
Weight Placement	35
Channel Extension Kit	36
Motor Jack and Base Assembly	37
Motor Installation	38
Sheave Installation	39
Electrical Assembly	42
Jack Support Assembly	46
Center Pivot Installation	48
Control Panel Setup	51
Calibration	56
Operation	57
Chapter 6 Start-up	58
Perform Pre-start Checks	58
Start the Auger	59
Chapter 7 Operation	60
Operating the Sweep Auger	60
Operating the Sweep Auger Control Panel	61
Chapter 8 Shut Down	62
Normal Shut Down	62
Emergency Shut Down	62
Storage Preparation	62
Chapter 9 Maintenance	63
Maintain the Auger	63
Lubrication	64

Table of Contents

Chapter 10 Control Panel Diagrams	69
Control Panel Schematic (460/3/60) Post-May 2010	69
Control Panel Schematic (460/3/60) Pre-June 2010	70
Chapter 11 Troubleshooting	71
FAQs	72
Chapter 12 Parts List	79
Main Auger Components	80
Flight Components	82
End Bearing Components	83
Auger Drive Components	84
Drive Assembly	86
Tractor Chain Guard Parts	88
Motor Mount Jack and Base Assembly (GC09993)	89
Jack Supports	90
Control Panel Components Pre-June 2010	92
Weight Extension Kit (GC12311)	95
Chapter 13 Warranty	97

Product Introduction

Congratulations. The selection of the GSI Series II Sweep is a wise investment. It will give you years of dependable service. The main function of the Series II Sweep is to clean out the remaining grain, from the bin, after all gravity unloading has finished. The GSI Series II Sweep is a single pass sweep only. The unit will only operate in a round grain bin equipped with a center sump in the bin floor. **NOTE:** *The bin manufacturer should be contacted for their recommendations on the bin's structural integrity. The following are sweep criteria recommendations.*

Issues	Recommendations
Flooring	A track is required under each of the sweep tires and jack wheels where they travel over the aeration (steel) floor. This is the case for all steel flooring including full floor and flush floor aeration. The track should be a minimum of 10 gauge thick and made from steel. The steel can be galvanized for the jack wheel paths but needs to have a non-slip coating for the drive tire paths. The drive tire track coating must not be course enough to damage the drive tires. A Chart on Page 17 is included that shows radius dimensions locating the points of contact between the sweep and the bin floor. The dimensions may be used to figure the material quantities of track to support the sweep across the aeration flooring. The track material is not supplied with the sweep and must be supplied by the installer or purchased from GSI. The dimensions are approximate and the assembled sweep should be checked for exact points of contact.
Center sump size	<p>If installing a sump with collector ring, the opening will be 42" x 42" for 12" sweep size.</p> <p>The sump hopper supplied by GSI was designed with sufficient clearance around the collector ring housing to allow grain to gravity flow through the hopper and be carried away by the material handling equipment below. 42-3/4" is the maximum opening size to allow rolling clearance for the casters assembled to the head end jack. If made smaller, grain flow may be decreased to an unacceptable level.</p> <p>**Flow of grain is limited to 15000 BPH when using this sump and collector ring housing assembly. The collector ring housing extends 22-1/2" down from the floor surface and is approximately 14-1/4" x 14-1/4" in size.</p>
Number of intermediate sumps	<p>Intermediate sump pumps must be installed on a maximum of 10' centers where the sweep will be parked during storage. The first intermediate sump should be placed at a maximum of 10' from the center sumps and the end sump should be no more than 4' from the bin wall.</p> <p>The extra sumps will help clean out the grain in front of the sweep, reducing the start-up load. Doing this will save labor dollars and hours of work to dig out the sweep and will help the sweep during start-up. The sweep is not designed to start-up when submerged in material. The sweep should be parked behind the intermediate sumps with sumps on the auger side of the sweep.</p>
Routing the power supply to the sweep	The only option is to use the hopper sump with collector ring. This allows the power to be transferred through a mechanical device in the center sump and does not twist any cords.
Floor level tolerance	The top edge of the sump hopper and the top edge of the "X" brace support must be level with the floor. The floor must be level within 3/4" plus (or) minus, preferably less. Any high or low points must be gradually sloped. The change in elevation should be no more than 3/4" over 60".
Bin roundness tolerance	Diameter tolerances are limited by foundation limits and sweep operation as well as structural issues. For 72' diameter and larger, the overall tolerance would be plus or minus 1-1/4" on the radius, plus or minus 1" on 42'-66' diameter bins and plus or minus 3/4" on 30'-39' bins.

1. Introduction

Issues	Recommendations
Bin opening size required for installation	The tail section is the largest piece of a standard Series II Sweep. The dimensions for a 12" tail section are 21-1/4" x 51-1/2". If the bin wall is not too thick, this unit should fit through a 21-1/2" x 45" opening.
Voltage specification	The Series II Sweep is designed to operate using 460 volt 3 phase 60 cycle power . The voltage must be within plus or minus 4% for proper operation. Voltages outside of this range may cause excessive power draw or other operating problems. Please contact the factory for applications outside of these parameters.
Electrical requirements	<p>Electrical controls and wiring should be installed by a qualified electrician. The conductor cables should comply with the National Electric Code and any local codes which may apply.</p> <p>Disconnect and lock out the power before servicing the equipment, entering the bin, or resetting the motor overloads.</p> <p>The control panel MUST be mounted OUTSIDE the bin near the door. It must be located so the operator has a full view of the equipment and can see that all personnel are clear. It must NEVER be installed inside the bin. The foot switch has to be plugged into the control panel and depressed before the sweep is operational. It has a 10' cord so the sweep can only be monitored from OUTSIDE the bin. The thermal protection cord must also be plugged in before the sweep will operate.</p>

Safety Guidelines

This manual contains information that is important for you, the owner/operator, to know and understand. This information relates to protecting **personal safety** and **preventing equipment problems**. It is the responsibility of the owner/operator to inform anyone operating or working in the area of this equipment of these safety guidelines. To help you recognize this information, we use the symbols that are defined below. Please read the manual and pay attention to these sections. Failure to read this manual and its safety instructions is a misuse of the equipment and may lead to serious injury or death.



This is the safety alert symbol. It is used to alert you to potential personal injury hazards. Obey all safety messages that follow this symbol to avoid possible injury or death.



DANGER indicates an imminently hazardous situation which, if not avoided, will result in death or serious injury.



WARNING indicates a potentially hazardous situation which, if not avoided, could result in death or serious injury.



CAUTION indicates a potentially hazardous situation which, if not avoided, may result in minor or moderate injury.



CAUTION used without the safety alert symbol indicates a potentially hazardous situation which, if not avoided, may result in property damage.



NOTE indicates information about the equipment that you should pay special attention.

Safety Instructions

Our foremost concern is your safety and the safety of others associated with this equipment. We want to keep you as a customer. This manual is to help you understand safe operating procedures and some problems which may be encountered by the operator and other personnel.

As owner and/or operator, it is your responsibility to know what requirements, hazards and precautions exist, and to inform all personnel associated with the equipment or in the area. Safety precautions may be required from the personnel. Avoid any alterations to the equipment. Such alterations may produce a very dangerous situation, where **SERIOUS INJURY** or **DEATH** may occur.

This equipment shall be installed in accordance with the current installation codes and applicable regulations which should be carefully followed in all cases. Authorities having jurisdiction should be consulted before installations are made.

Follow Safety Instructions

Carefully read all safety messages in this manual and safety signs on your machine. Keep signs in good condition. Replace missing or damaged safety signs. Be sure new equipment components and repair parts include the current safety signs. Replacement safety signs are available from the manufacturer.

Learn how to operate the machine and how to use controls properly. Do not let anyone operate without instruction.

Keep your machinery in proper working condition. Unauthorized modifications to the machine may impair the function and/or safety and affect machine life.

If you do not understand any part of this manual or need assistance, contact your dealer.

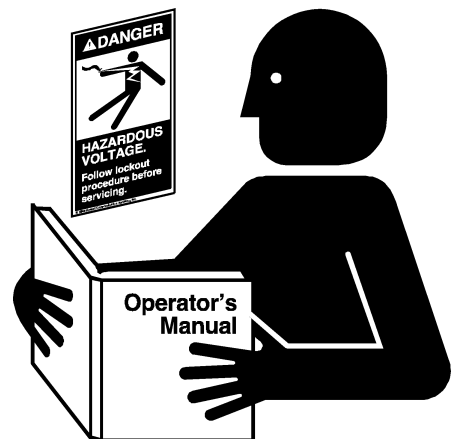

Read and Understand Manual

Keep Hands Away from Moving Parts

DO NOT put hand or arm in hopper. Rotating auger can crush and dismember.

DO NOT put any kind of tool inside hopper to try and clear debris while the auger is running. Damage to the equipment will result.

ALWAYS turn off and lock out all power sources before servicing equipment.

Keep all shields and covers in place during operation.



Rotating Auger

Operate Motor Properly

In an emergency, shut down the power source.

Turn OFF and lock out all power sources before performing any maintenance.

Do not operate electric motor equipped units until motors are properly grounded.

Disconnect power on electrical driven units before resetting motor overloads.

Do not repetitively stop and start the drive in order to free a plugged condition. Jogging the drive in this manner can damage the equipment and/or drive components.

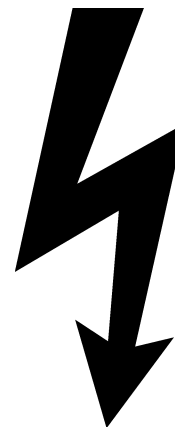

Electric Shock Hazard

Practice Safe Maintenance

Understand service procedures before doing work. Keep area clean and dry.

Never lubricate, service, or adjust machine while it is in operation. Keep hands, feet and clothing away from rotating parts.

Keep all parts in good condition and properly installed. Fix damage immediately. Replace worn or broken parts. Remove any built up grease oil and debris.



**Maintain Equipment
and Work Area**

Prepare for Emergencies

Be prepared if fire starts.

Keep a first aid kit and fire extinguisher handy.

Keep emergency numbers for doctors, ambulance service, hospital and fire department near your telephone.

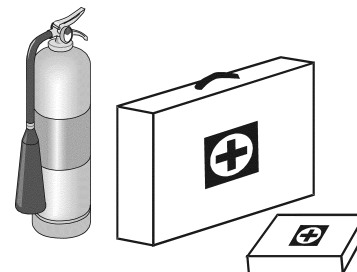

**Keep Emergency Equipment
Quickly Accessible**

2. Safety

Wear Protective Clothing

Wear close fitting clothing and safety equipment appropriate to the job.

Remove all jewelry.

Long hair should be tied up and back.

Safety glasses should be worn at all times to protect eyes from debris.

Wear gloves to protect your hands from sharp edges on plastic or steel parts.

Wear steel toe boots to help protect your feet from falling debris. Tuck in any loose or dangling shoe strings.

A respirator may be needed to prevent breathing potentially toxic fumes and dust.

Wear hard hat to help protect your head.

Wear appropriate fall protection equipment when working at elevations greater than six feet (6').

Eye Protection

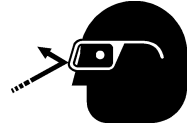

Gloves



Steel Toe Boots



Respirator



Hard Hat



Fall Protection



Operate Unload Equipment Properly



**Operate Unload
Equipment Safely**

- Untrained operators subject themselves and others to **SERIOUS INJURY** or **DEATH**. **NEVER** allow untrained personnel to operate this equipment.
- **NEVER** work alone.
- Keep children and other unqualified personnel out of the working area at **ALL** times. Refer to the **Start-Up** section of this manual for diagrams of the work area.
- Make sure **ALL** equipment is locked in position before operating.
- **NEVER** start equipment until **ALL** persons are clear of the work area.
- Keep hands and feet away from the auger intake and other moving parts.
- **NEVER** attempt to assist machinery operation or to remove trash from equipment while in operation.
- Be sure all operators are adequately rested and prepared to perform all functions of operating this equipment.
- **NEVER** allow any person intoxicated or under the influence of alcohol or drugs to operate the equipment.
- Make sure someone is nearby who is aware of the proper shut down sequence in the event of an accident or emergency.
- **ALWAYS** think before acting. **NEVER** act impulsively around the equipment.
- **NEVER** allow anyone inside a bin, truck or wagon which is being unloaded by an auger or conveyor. Flowing grain can trap and suffocate in seconds.
- Use ample overhead lighting after sunset to light the work area.
- Keep area around intake free of obstacles such as electrical cords, blocks, etc., that might trip workers.
- **NEVER** drive, stand or walk under the equipment.
- Use caution not to hit the auger when positioning the load.
- **ALWAYS** lock out **ALL** power to the equipment when finished unloading a bin.
- Be aware of pinch points. A pinch point is a narrow area between two surfaces that is likely to trap or catch objects and so is a potential safety hazard.

Operator Qualifications

- A. The User/Operator must be competent and experienced to operate auger equipment. Anyone who works with or around augers must have good common sense in order to be qualified. These persons must also know and meet all other qualifications, such as:
- i. Any person who has not read and/or does not understand all operation and safety procedures is not qualified to operate any auger systems.
 - ii. Certain regulations apply to personnel operating power machinery. Personnel under the age of 18 years may not operate power machinery, including augers. It is your responsibility, as owner and/or supervisor, to know what these regulations are in your area or situation.
 - iii. Unqualified or incompetent persons are to remain out of the work area.
 - iv. O.S.H.A. (Occupational Safety and Health Administration) regulations state: “At the time of initial assignment and at least annually thereafter, the employer shall instruct every employee in the safe operation and servicing of all equipment with which the employee is, or will be involved”. (Federal Occupational Safety and Health Standards for Agriculture. Subpart D, Section 1928.57 (a) (6)).
- B. As a requirement of O.S.H.A., it is necessary for the employer to train the employee in the safe operating and safety procedures for this auger. The sign-off sheet is provided for your convenience and personal record keeping. All unqualified persons are to stay out of the work area at all times. It is strongly recommended that another qualified person who knows the shut down procedure is in the area in the event of an emergency.

<i>Date</i>	<i>Employee Name</i>	<i>Supervisor Name</i>

3. Safety Decals

The images below show the location of the decals and safety signs which should appear on the Series II Sweep. ([Refer to Page 14-16](#) for decals.)

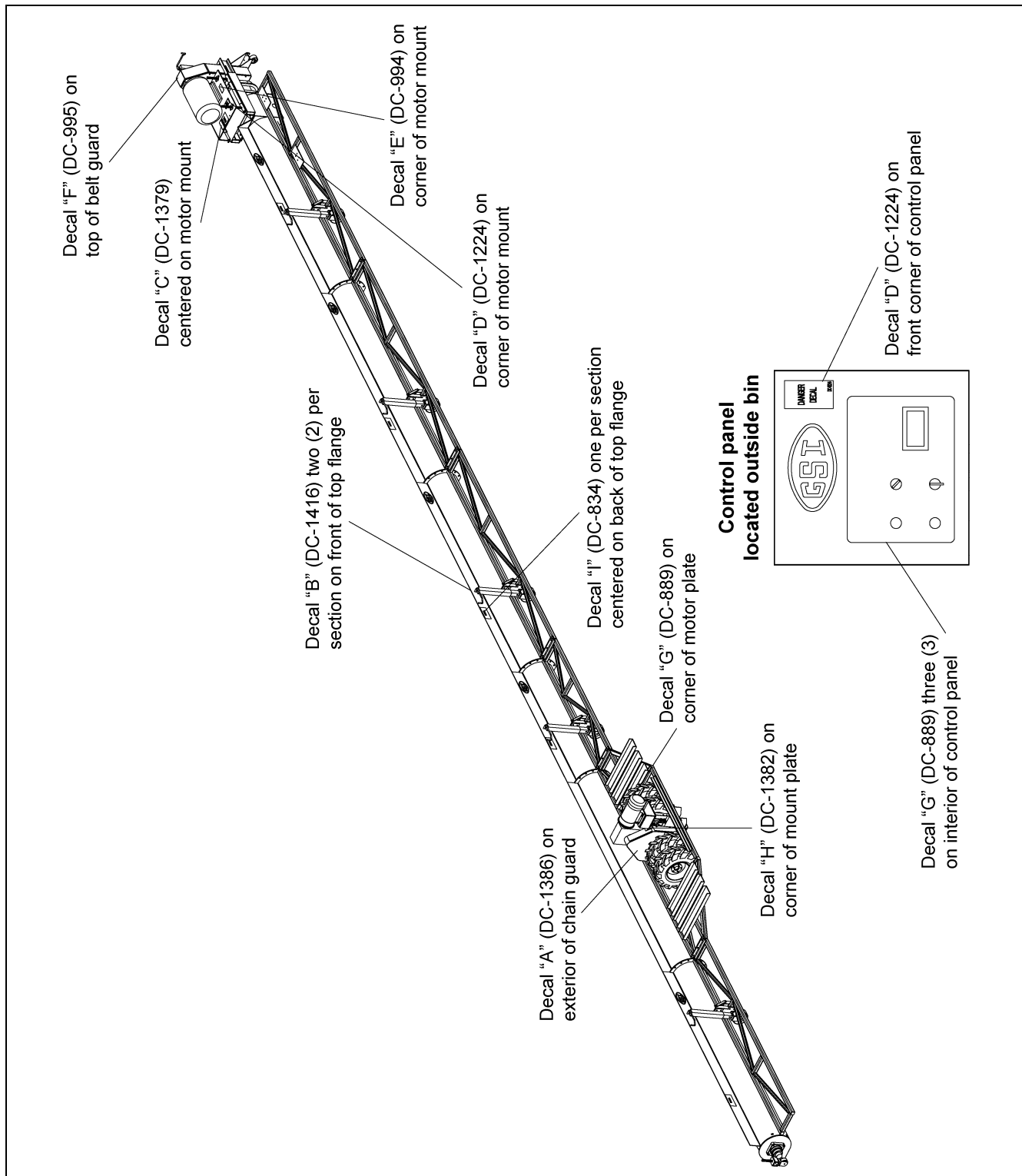

NOTE: Please remember safety signs provide important safety information for people working near bin unloading equipment that is in operation.

Any safety signs that are worn, missing, illegible or painted over should be replaced immediately. Obtain FREE replacements by contacting GSI.

3. Safety Decals

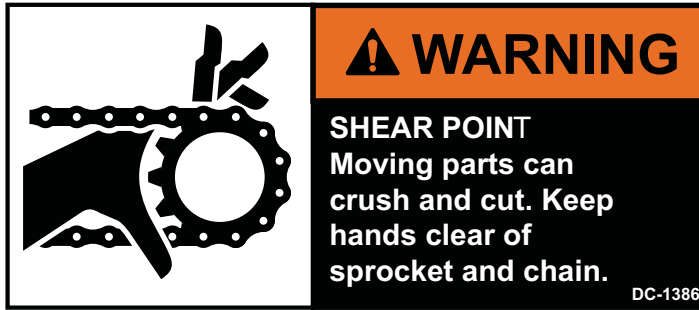

Decal "A"

Location: Exterior of chain guard

Size: 2" x 4-1/2"

Part #: DC-1386

NOTICE

1. READ AND UNDERSTAND THE OPERATOR'S MANUAL AND ALL SAFETY INSTRUCTIONS.
2. DO NOT OPERATE WHILE UNDER THE INFLUENCE OF DRUGS OR ALCOHOL.
3. DO NOT OPERATE UNLESS ALL SAFETY EQUIPMENT, SWITCHES, GUARDS AND SHIELDS ARE SECURELY IN PLACE AND OPERATIONAL.
4. ALLOW ONLY TRAINED AUTHORIZED PERSONNEL IN THE OPERATING AREA.
5. ANY ELECTRICAL WIRING OR SERVICE WORK MUST BE PERFORMED BY A QUALIFIED ELECTRICIAN. IT MUST MEET ALL STATE AND LOCAL ELECTRICAL CODES.
6. DO NOT ALLOW CHILDREN IN THE AREA OF OPERATION.
7. KEEP HANDS, FEET AND CLOTHING AWAY FROM MOVING PARTS.
8. DISCONNECT AND LOCKOUT POWER BEFORE MAKING ANY ADJUSTMENTS OR PERFORMING ANY SERVICE WORK.
9. DISCONNECT POWER PRIOR TO RESETTING ANY MOTOR OVERLOAD.
10. MAKE CERTAIN ALL ELECTRIC MOTORS ARE GROUNDED.
11. REPLACE ALL WORN OR DAMAGED LABELS IMMEDIATELY.

DC-1379

Decal "C"

Location: Centered on motor mount

Size: 5-1/2" x 7-3/8"

Part #: DC-1379



Decal "B"

Location: Two (2) per section on front of top flange

Size: 4-5/16" x 5-7/16"

Part #: DC-1416

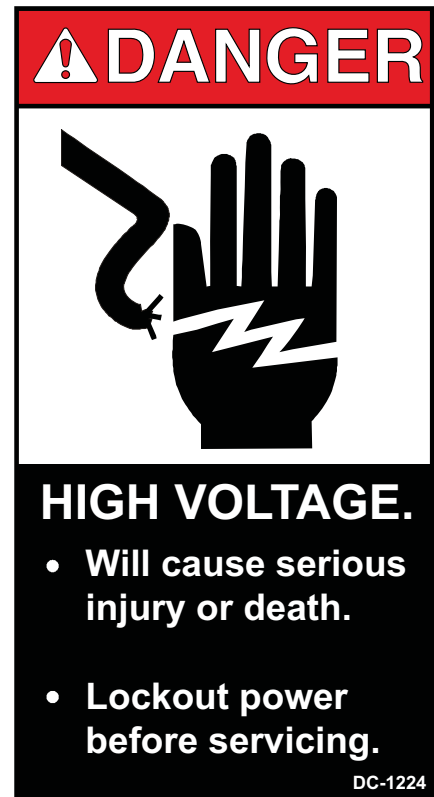

Decal "D"

Location: Corner of motor mount

Size: 2-7/8" x 5"

Part #: DC-1224

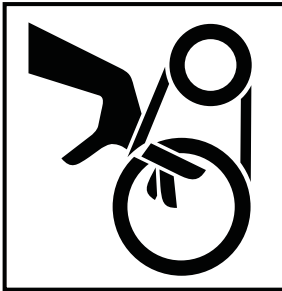

⚠ DANGER
SHEAR POINT
 Keep hands clear of moving parts. Do not operate with guard removed. Disconnect and lockout power before servicing.

DC-994

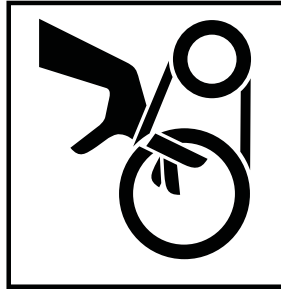

⚠ WARNING
SHEAR POINT
 Keep hands clear of moving parts. Do not operate with guard removed. Disconnect and lockout power before servicing.

DC-995

Decal "E"

Location: Corner of motor mount
 Size: 4-1/2" x 2"
 Part #: DC-994

Decal "F"

Location: Top of belt guard
 Size: 4-1/2" x 2"
 Part #: DC-995

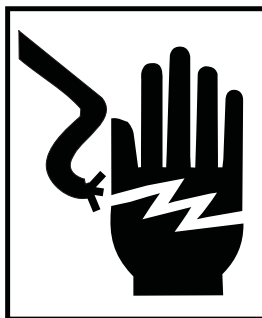

⚠ DANGER
HIGH VOLTAGE.
 Will cause injury or death.
 Lockout power before servicing.

DC-889

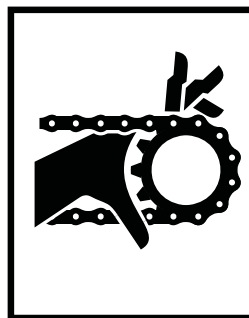

⚠ DANGER
SHEAR POINT
 Moving parts can crush and cut. Keep hands clear of sprocket and chain.

DC-1382

Decal "G"

Location: Corner of motor mount
 Size: 2-13/16" x 17/16"
 Part #: DC-889

Decal "H"

Location: Corner of mount plate
 Size: 4" x 1-3/4"
 Part #: DC-1382

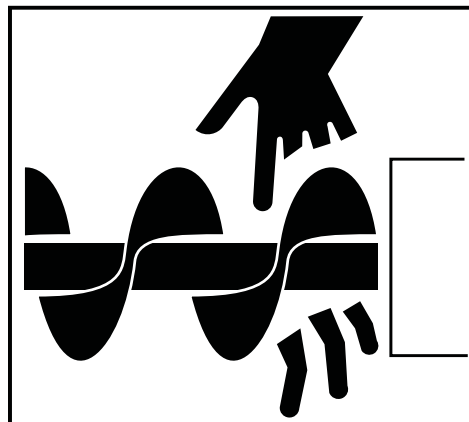

**Rotating flying
 can kill or dismember.**

⚠ DANGER

1. Keep all safety shields and devices in place.
2. Keep hands, feet, hair, loose clothing, and other objects away from moving parts.
3. Do not operate the machine unless visitors, children, and all other untrained personnel are well clear of the machine and work area.
4. Stop the machine and lock out power to clean, lubricate, service, or adjust.
5. Read operation and assembly manual completely before using equipment.

**Failure to heed these warnings will
 result in serious injury or death.**

DC-834

Decal "I"

Location: One per section centered on back of top flange
 Size: 9" x 3-3/4"
 Part #: DC-834

3. Safety Decals

- A. DANGER Sign No. DC-1395 was supplied with your bin unloading equipment. This safety sign should be applied to the side of the bin near the bin opening, so it will be viewed by people entering into the bin storage building. Do not cover any safety signs or any other signs that are already there.
- B. If the safety sign location suggested is not in full view because of equipment modifications, other equipment in the area or any reason, then locate the safety sign in a more suitable location.
- C. Be certain the surface is clean, dry and free of dirt and oil. Peel paper backing from decals and stick into place. The adhesive backing will bond on contact.

NOTE: *Please remember, safety signs provide important safety information for people working near bin unloading equipment that is in operation.*

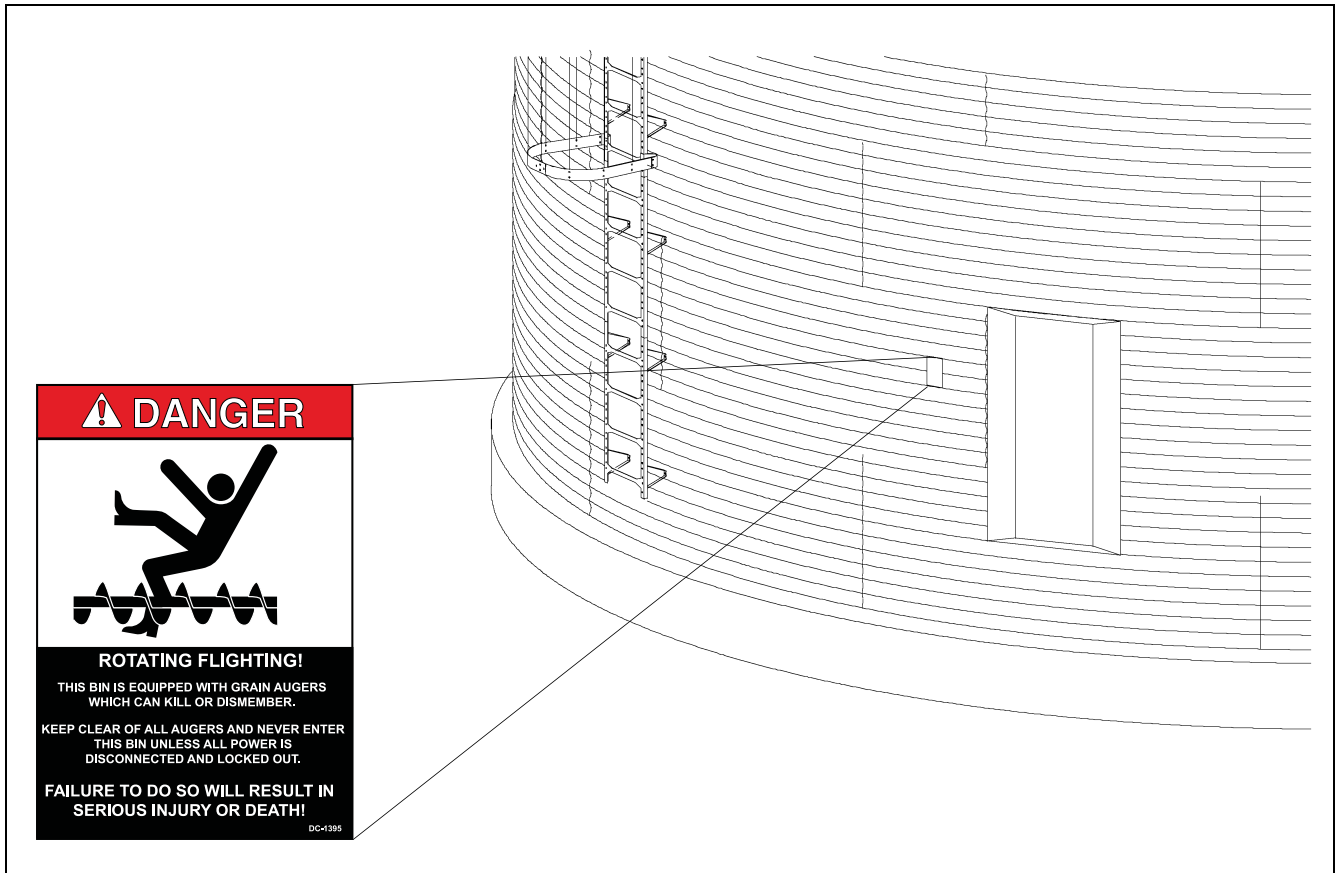

NOTE: *If the Safety Sign cannot be easily read for any reason or has been painted over, replace it immediately. Additional Safety Signs may be obtained free of charge from your dealer, distributor or ordered from the factory.*

Order SAFETY SIGN NO. DC-1395

Product Information



This Series II Sweep is a single pass sweep. Consult the manufacturer of the storage tank regarding the requirements or restrictions of the sweeping process. The manufacturer may require a multiple pass sweep.

A. The Series II Sweep includes the following components.

- Control panel
- Two (2) motors
- Motor covers
- Motor mount
- Auger flighting
- Auger back shield assembly
- Jack supports

B. The unit will operate only in a round grain bin equipped with a center sump in the bin floor.



NEVER enter a grain bin unless ALL power driven equipment has been shut down. Disconnect and lock out power before entering the bin or servicing the equipment.

General Information

A. GSI reserves the right to improve its product whenever possible and practical to do so. We reserve the right to change, improve and modify products at any time without obligation to make changes, improvements and modifications on equipment sold previously.

B. This new bin sweep auger has been engineered and manufactured to give years of dependable service. The care and maintenance of this equipment will affect the satisfaction and service obtained. By following the instructions and recommendations, the owner should receive quality service for many years. If additional information or assistance is required, please contact GSI.

C. It is important to check both the quantity of parts and their descriptions with the packing list enclosed within each package. All claims for freight damage or shortage must be made by the consignee within ten (10) days of the date of the occurrence. The consignee should accept the shipment after noting the damage or loss on the bill of lading.

D. The [Chart below](#) shows radius dimensions locating the points of contact between the sweep and the bin floor. The dimensions may be used to figure material quantities of track to support the sweep across the aeration flooring. The track material is not supplied with the sweep and must be supplied by the installer. The dimensions are approximate and the assembled sweep should be checked for exact points of contact.

Radius Dimensions from Center of Bin								
Bin Diameter	# of Sections	Head Jack Wheel 2" Wide	Intermediate Jack Wheel 3" Wide	Intermediate Jack Wheel 3" Wide	Intermediate Jack Wheel 3" Wide	Inside Tire 18" Wide	Outside Tire 18" Wide	Extension Jack Wheel 3" Wide
131'	6	92"	236"	380"	468"	537-1/4"	574-1/2"	677"
135'	6	92"	236"	380"	484"	561-1/4"	598-1/2"	701"

Capacities and Specifications



Electrical controls and wiring should be installed by a qualified electrician. The motor disconnect switches and conductor cables should comply with the National Electrical Code and any local codes. Locate reset and motor starting stations so the operator can see that all personnel are clear of the equipment.

A. Use the [Chart below](#) to determine the horsepower required.

NOTE: Sweep is not designed to start under full load.

12" Series II Sweep					
Bin Diameter	Drive HP	Bushel/MT per Hour Horsepower			Length Pivot to End
		5000/125	6000/155	7000/180	
131'	5	N/A	20	N/A	63.84' (19.46 m)
135'	5	N/A	20	N/A	65.84' (20.07 m)

NOTE: The horsepower recommendations are for augering reasonably dry grain. High moisture grain (greater than 15%) will require greater power for maximum capacity.

NOTE: Sweep drive and carrier wheels require plates or track over aeration flooring for travel and supports not supplied with the sweep unit. Contact the installer or flooring provider for possible sources and details.

- B. A magnetic starter should be used to protect the motor when starting and stopping. It should stop the motor in case of power interruption, conductor fault, low voltage, circuit interruption or motor overload. The motor must be restarted manually. Some motors have built-in thermal overload protection. If this is the type of motor being used, use only those with a manual reset.
- C. The motor starting controls must be located outside the bin. They must NEVER be installed on the Series II auger inside the bin.
- D. Disconnect and lock out the power before resetting motor overloads.
- E. Disconnect and lock out the power before entering the bin.
- F. Disconnect and lock out the power before servicing the equipment.
- G. Position the reset and motor starting controls so that the operators have full view of the equipment.



There should ALWAYS be two (2) people in the work area.

H. Make sure electric motors are grounded.



A main power disconnect switch capable of being locked only in the OFF position should be used. It should be locked in the OFF position whenever work is being done on the Series II Sweep.

Torque Values to be used when Tightening the Bolts on the Series II Sweep

It takes more force to tighten a 3/4"-10 bolt than to tighten a 1/2"-13 bolt because of its larger diameter. It also takes more force to tighten a grade 8 bolt than it does to tighten a grade 5 bolt because of the greater material strength. A bolt that is waxed or otherwise lubricated requires much less force to tighten. If the same amount of force is used with a lubricated bolt as with a non-lubricated bolt, the lubricated bolt often will break.

A suggested initial tightening torque is listed in the *Chart below*.

Size	Grade #5 Assembly Torque		Grade #8 Assembly Torque	
	Dry	Lubricated	Dry	Lubricated
1/4"-20	8 ft. lbs.	75 in. lbs.	12 ft. lbs.	9 ft. lbs.
1/4"-28	10 ft. lbs.	86 in. lbs.	14 ft. lbs.	10 ft. lbs.
5/16"-18	17 ft. lbs.	13 ft. lbs.	25 ft. lbs.	18 ft. lbs.
5/16"-24	19 ft. lbs.	14 ft. lbs.	25 ft. lbs.	20 ft. lbs.
3/8"-16	30 ft. lbs.	23 ft. lbs.	45 ft. lbs.	35 ft. lbs.
3/8"-24	35 ft. lbs.	25 ft. lbs.	50 ft. lbs.	35 ft. lbs.
1/2"-13	75 ft. lbs.	55 ft. lbs.	110 ft. lbs.	80 ft. lbs.
1/2"-20	90 ft. lbs.	65 ft. lbs.	120 ft. lbs.	90 ft. lbs.
5/8"-11	150 ft. lbs.	110 ft. lbs.	220 ft. lbs.	170 ft. lbs.
5/8"-18	180 ft. lbs.	130 ft. lbs.	240 ft. lbs.	180 ft. lbs.
3/4"-10	260 ft. lbs.	200 ft. lbs.	380 ft. lbs.	280 ft. lbs.
3/4"-16	300 ft. lbs.	220 ft. lbs.	420 ft. lbs.	320 ft. lbs.
7/8"-9	320 ft. lbs.	320 ft. lbs.	600 ft. lbs.	460 ft. lbs.
1"-8	640 ft. lbs.	480 ft. lbs.	900 ft. lbs.	680 ft. lbs.
1-1/8" - 7	800 ft. lbs.	600 ft. lbs.	1280 ft. lbs.	960 ft. lbs.
1-1/4" - 7	1120 ft. lbs.	840 ft. lbs.	1820 ft. lbs.	1360 ft. lbs.
1-3/8" - 6	1460 ft. lbs.	1100 ft. lbs.	2380 ft. lbs.	1780 ft. lbs.
1-1/2" - 6	1910 ft. lbs.	1460 ft. lbs.	3160 ft. lbs.	2360 ft. lbs.

Grade 5 Bolts

Grade 5 bolts are designated by three (3) slash marks on the head.

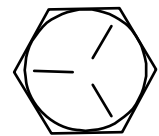

Grade 8 Bolts

Grade 8 bolts are designated by six (6) slash marks evenly spaced on the head of the bolt.

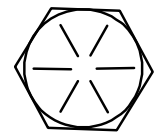

Grade 8.2 Bolts

Grade 8.2 bolts are designated by six (6) slash marks on the head in a sunrise pattern.

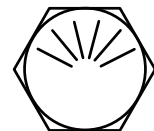

Under no condition shall any other fasteners be substituted for those supplied by the manufacturer.

4. General Product Information

Taper-lock Bushings

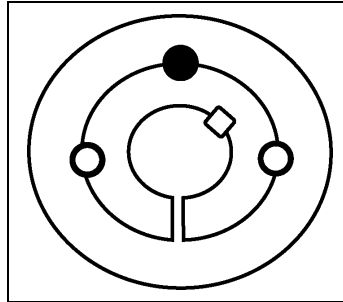

- Insert set screws to install
- Insert set screw to remove

Figure 4A Number 1008 to 3030 Bushing



Wedging forces in the bushing saw slot, such as that exerted by a narrow edged regular screw driver, may damage or break the bushing. This damage would not be covered under the GSI warranty.



Do not lubricate the bushing taper, bushing bore, hub taper or the shaft. Doing so could result in breakage of the product.

Do not use worn hex key wrenches. Doing so may result in a loose assembly or may damage the screws.

To Install

1. Clean shaft, bore and outside of bushing and hub bore of all oil, paint and dirt. File away burrs.
2. Insert bushing in hub. Match the hole pattern, not threaded holes (each complete hole will be threaded on one side only).
3. Lightly oil set screws and thread into the half-threaded holes indicated as in [Figure 4A](#).
4. Position the assembly onto the shaft allowing for the small axial movement which will occur during the tightening procedure.
5. Alternately torque set screws to recommended torque setting listed in the [Chart below](#).
6. To increase the gripping force, hammer the face of the bushing using a drift or sleeve. (Do not hit the bushing directly with the hammer.)
7. Re-torque the screws after hammering.
8. Recheck the screw torques after the initial run-in and periodically thereafter. Repeat [Steps 5, 6](#) and [7](#) if loose.

Recommended Installation Wrench Torque

Bushing #	lbs.-in	Bushing #	lbs.-in
1008, 1108	55	3535	1000
1210, 1215, 1310	175	4040	1700
1610, 1615	175	4545	2450
2012	280	5050	3100
2517, 2525	430	6050, 7060, 8065	7820
3020, 3030	800		

To Remove

1. Remove all screws.
2. Insert screws in hole or holes indicated on [Figure 4A on Page 20](#). Loosen the bushing by tightening the screw(s).

Q-D Bushings - Reverse Mounting

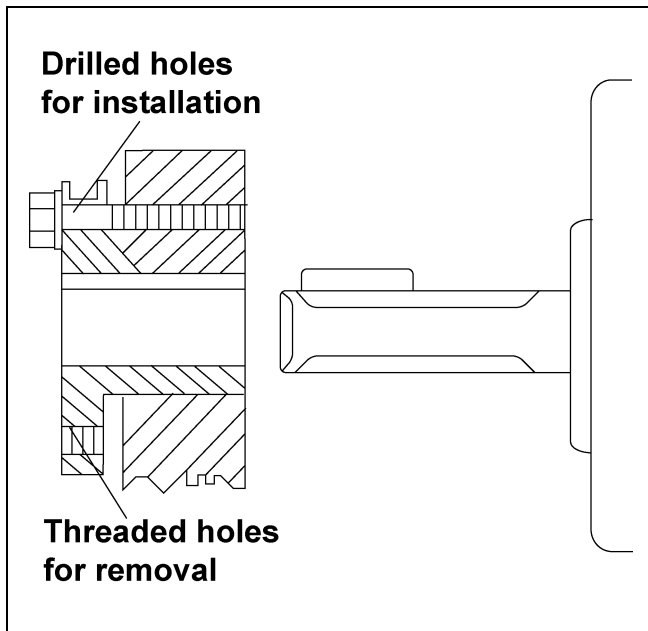

Figure 4B

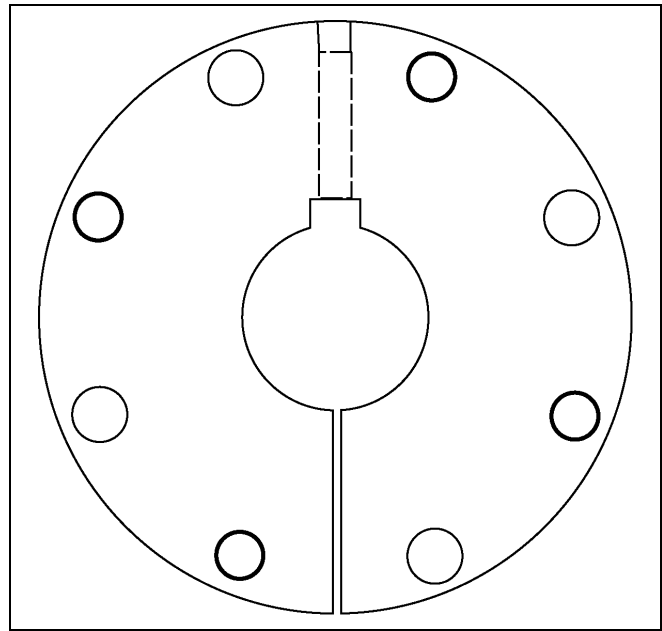

Figure 4C Overhead View of Q-D Bushing

To Install

1. Clean shaft, bore of bushing, outside of bushing and hub bore of all oil, paint and dirt. File away burrs.
2. Reverse mounting: Place the bushing in hub and insert the cap screws through the drilled holes in the bushing flange. Tighten the cap screws, finger tight into threaded holes in the hub.
3. With the key on the shaft, slide the loosely assembled unit onto the shaft so that the cap screw heads are on the outside. Place the unit in the desired position on the shaft.
4. Tighten the cap screws alternately and evenly to the wrench torque specified in the [Chart on Page 22](#).

NOTE: When tightened, there will be a gap of 1/8" to 1/4" between the bushing flange and the hub. Should this gap be less, either undersize shafting or the wrong bushing shaft size was used.
5. Tighten the set screw (if supplied) over the key to the torque value listed in the [Chart on Page 22](#).

4. General Product Information

Recommended Installation Wrench Torque

Bushing	Cap Screw		Key Seat Set Screw	
	Size	lbs.-in	Size	lbs.-in
H	1/4"-20 x 7/8"	90	N/A	N/A
JA	#10-24 x 1"	60	N/A	N/A
SH	1/4"-20 x 1-3/8"	108	1/4"-20	87
SDS	1/4"-20 x 1-3/8"	108	1/4"-20	87
SD	1/4"-20 x 1-7/8"	108	1/4"-20	87
SK	5/16"-18 x 2"	180	1/4"-20	87
SF	3/8"-16 x 2"	360	3/8"-16	290
E	1/2"-13 x 2-3/4"	720	3/8"-16	290
F	9/16"-12 x 3-5/8"	900	3/8"-16	290
J	5/8"-11 x 4-1/2"	1620	1/2"-13	620
M	3/4"-10 x 6-3/4"	2700	1/2"-13	620

To Remove

1. Remove all cap screws.
2. Insert the cap screws into the threaded jack hole or holes.
3. Tighten all the jack screws alternately and evenly beginning with the screw farthest from the bushing saw slot. Tighten until the bushing grip is released. Slide the unit off the shaft.



Do not lubricate the bushing taper, bushing bore, hub taper or the shaft. Doing so could result in breakage of the product.

Excessive screw torque may cause damage to either the bushing and/or the sheave. Uneven pressure on the jack screws may also damage the bushing flange making removal difficult without damage to the bushing and/or sheave.

Do not use worn hex keys and/or wrenches. Doing so may result in a loose assembly or may damage the screws.

Back Shield Assembly

A. The sweep has been broken down into four (4) different section types: the head, intermediate, tail and extension sections.

NOTE: Use the [Chart below](#) to determine the identification and the order of assembly of the individual sweep sections.

12" Series II Sweep Sections								
Bin Diameter	# of Sections	Head	Intermediate	Intermediate	Intermediate	Tail	Extension	Pivot to End
131'	6	136"	144"	144"	60"	144"	137-1/2"	63.84'
135'	6	136"	144"	144"	84"	144"	137-1/2"	65.84'



The section sizes are total length given in inches. The head section has 8" subtracted from the shield length due to the pivot pipe location. The 12" tail section has 5-1/2" added to the shield length due to the end shaft length.

B. Use eight (8) 5/8"-11 x 1-3/4" grade 8 hex bolts, lock washers and hex nuts at each section connection.



The bolts MUST be installed as shown in [Figure 5A](#).

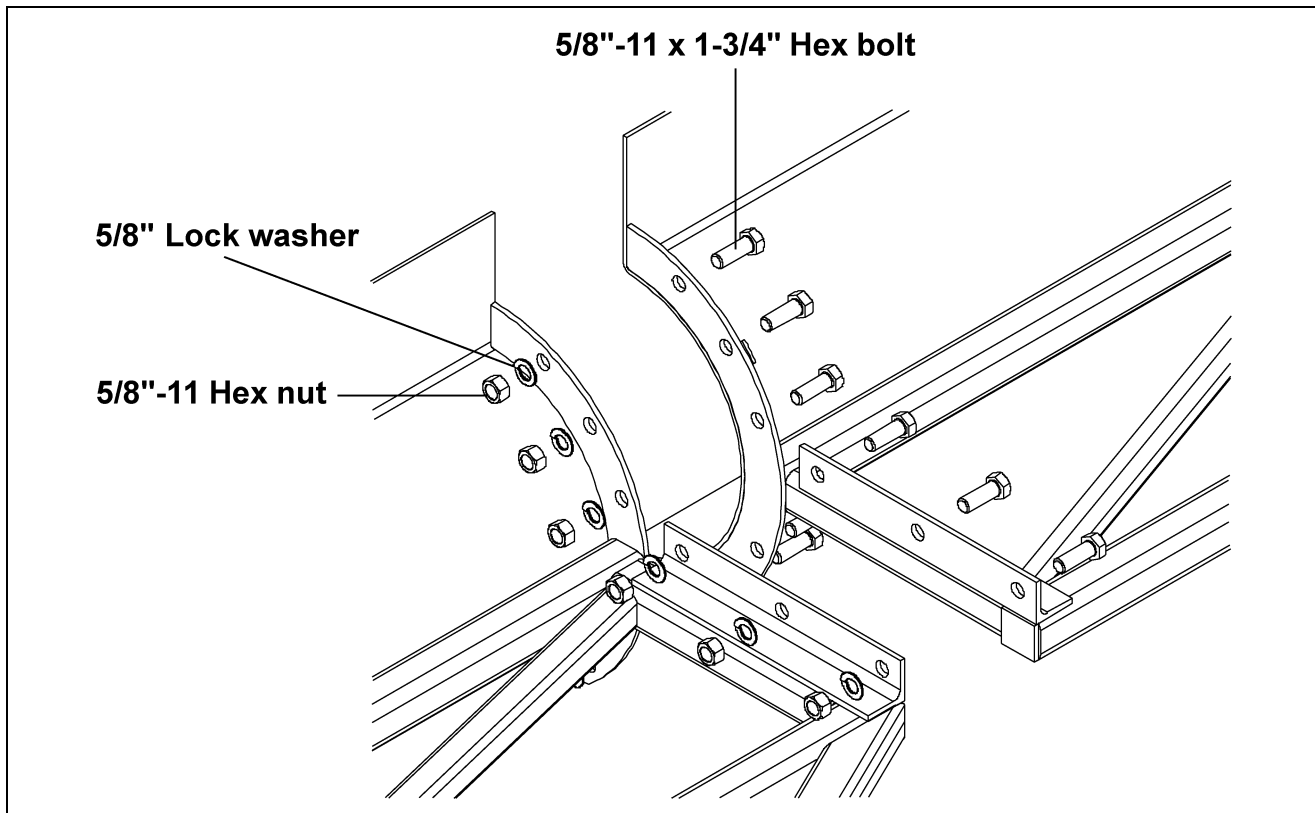

Figure 5A

Flighting Assembly

- A. Lay out the flight sections in order of assembly starting with the head flight working towards the tail flight.
- B. Using the connecting stubs, bolt the flight sections together with hex bolts and lock nuts. Make sure the flight ends are in time with each other.

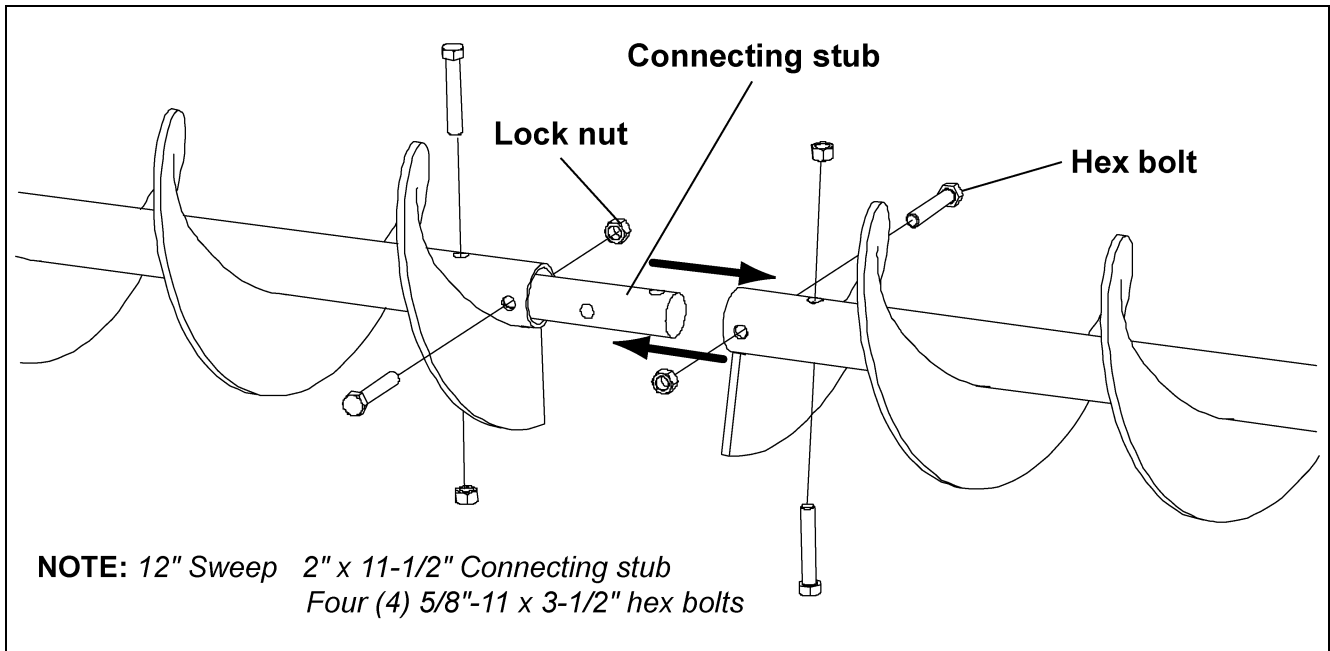

Figure 5B

- C. Slide the end stub through the bearing plate on the tail section and into the tail flight securing it with hex bolts and lock nuts.

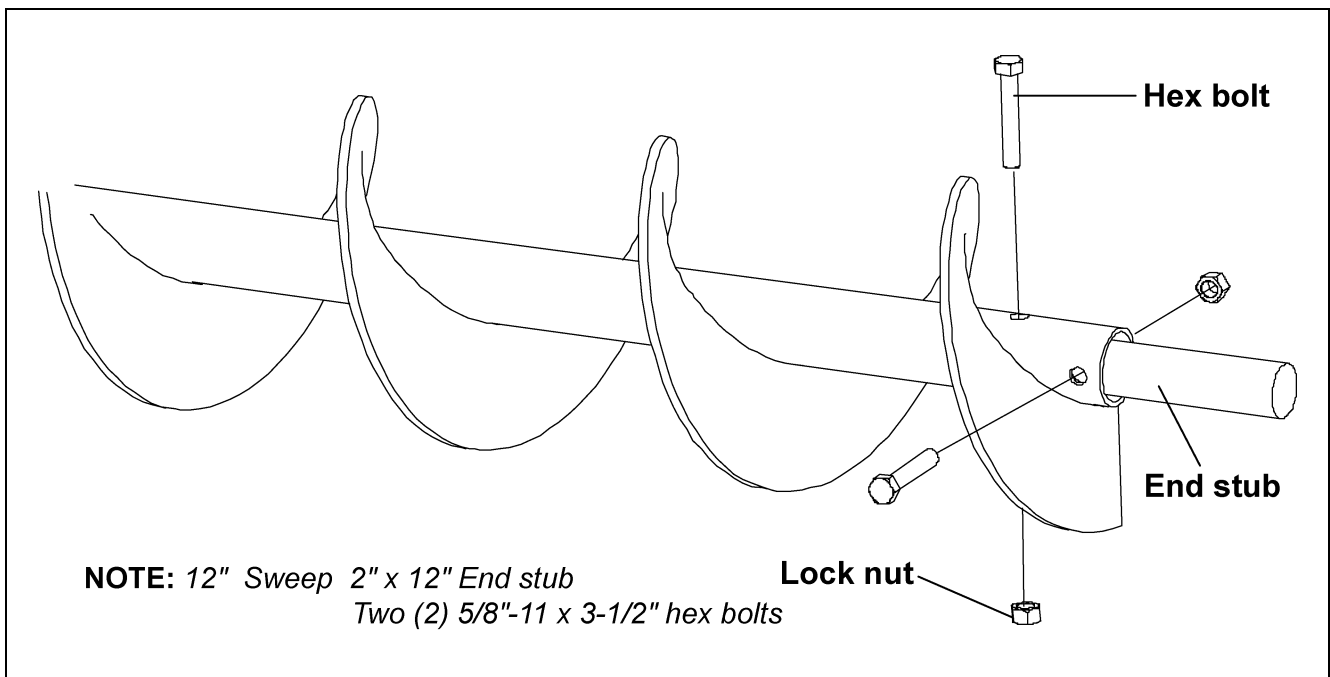

Figure 5C

Hanger Bracket Assembly

- A. Bolt the nylon bearings and hanger brackets to the connecting stubs using hex bolts, lock washers and hex nuts as shown in [Figure 5D](#).

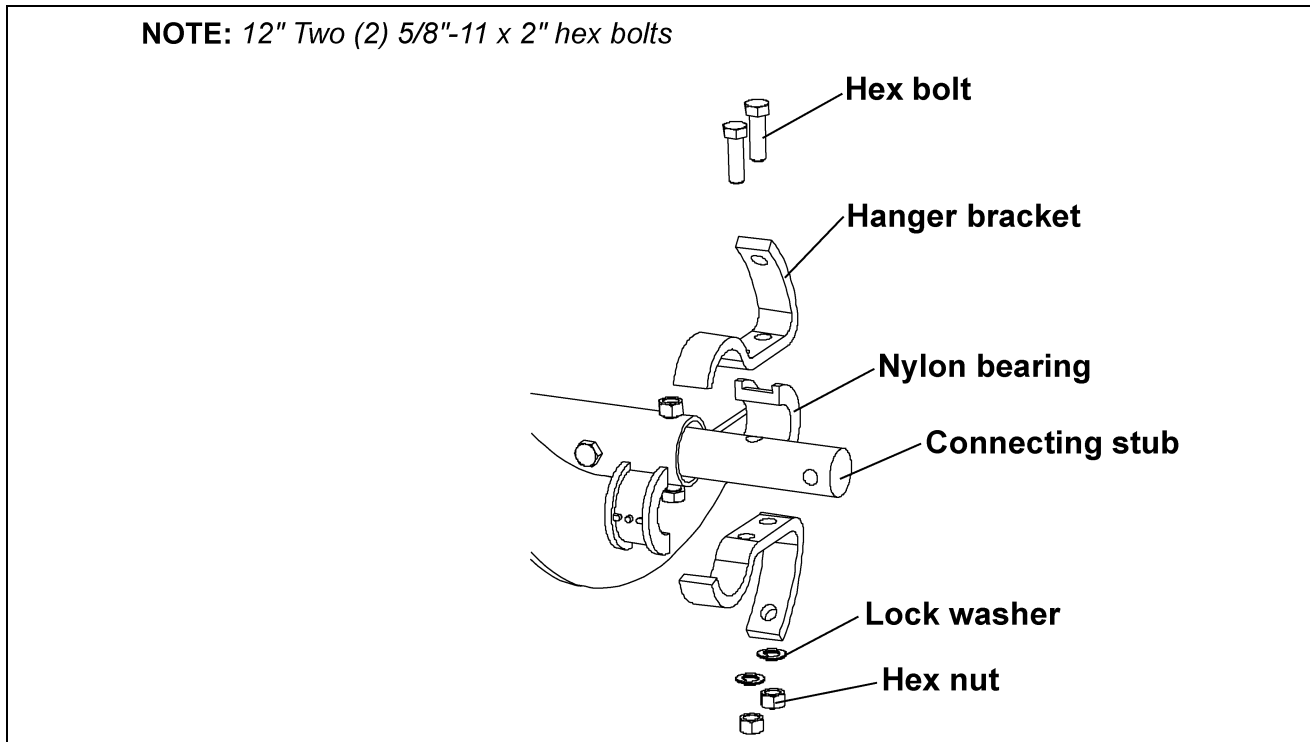

Figure 5D

- B. Bolt the hanger brackets to the back shields using two (2) 5/8"-11 x 2" hex bolts, two (2) square washers, two (2) lock washers and two (2) hex nuts as shown in [Figure 5E](#).

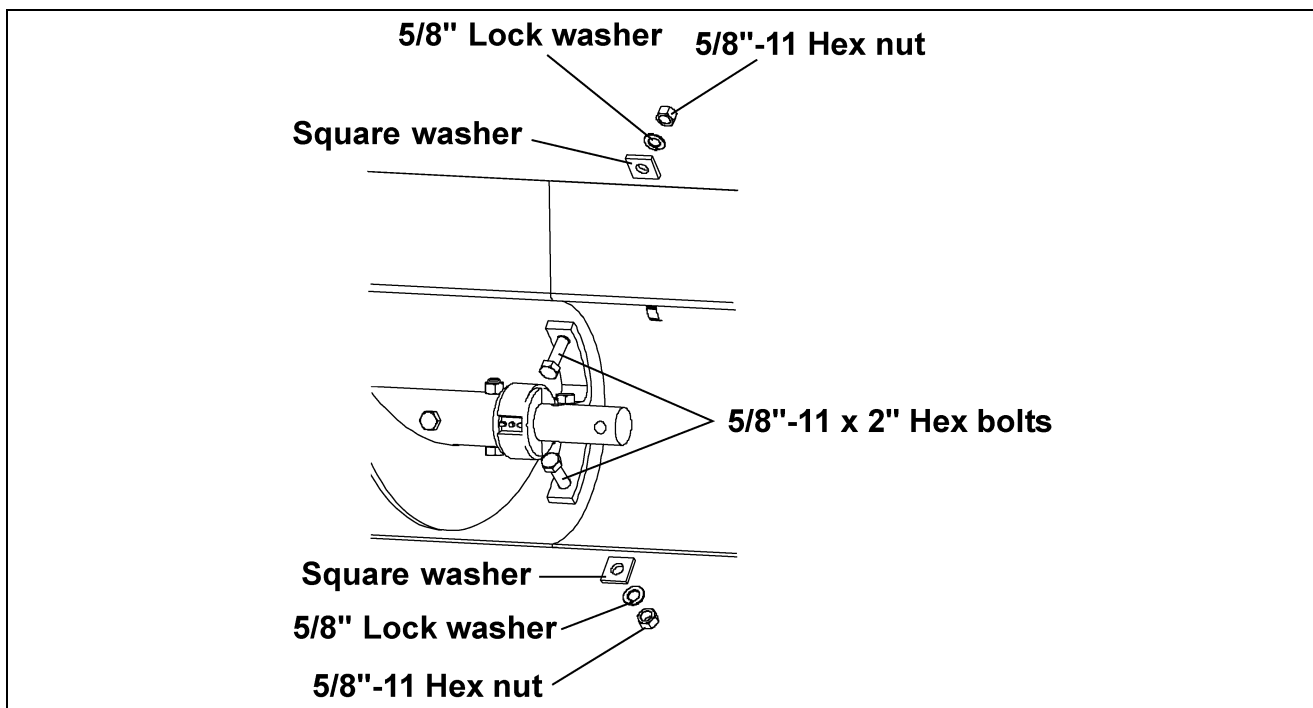

Figure 5E

Flange Bearing Assembly

A. Slide the flange bearing onto the end stub and bolt it to the end plate using hex bolts, lock washers and hex nuts as shown in [Figure 5F](#).

NOTE: Do not tighten the set screws on the bearing at this time. This can be done after the gear reducer is installed.

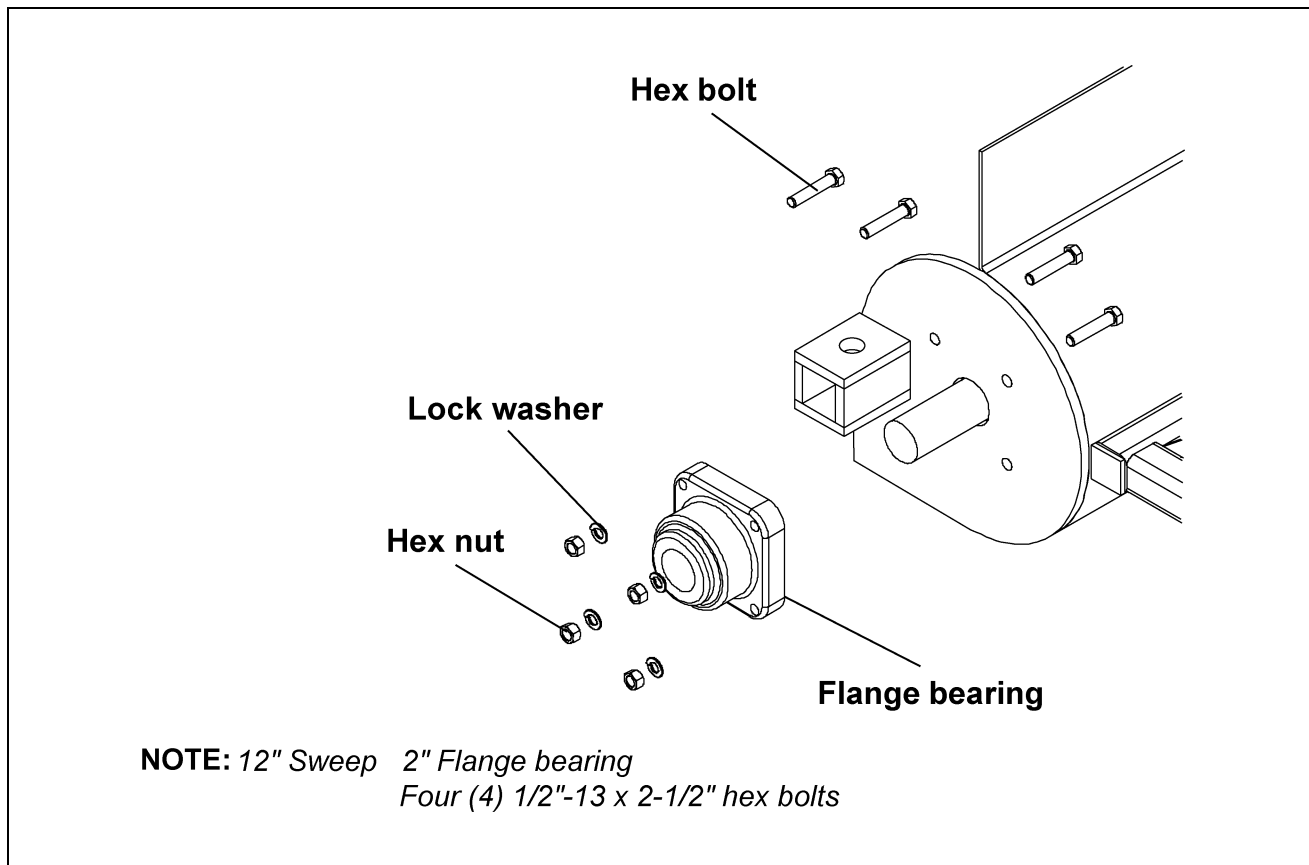

Figure 5F

Gear Reducer Assembly

A. Slide the output shaft of the reducer through the end plate of the head section and into the end of the head flight. Secure the reducer output shaft to the head flight with hex bolts and lock nuts. ([See Figure 5G on Page 27.](#))

B. Bolt the reducer to the end plate of the head section using hex bolts, flat washers and lock washers, supplied with the reducer. ([See Figure 5G on Page 27.](#))

NOTE: The input shaft of the reducer **MUST** be to the top of the reducer. Refer to the Owner's manual supplied with the reducer for proper vent plug, fill plug and drain plug locations.

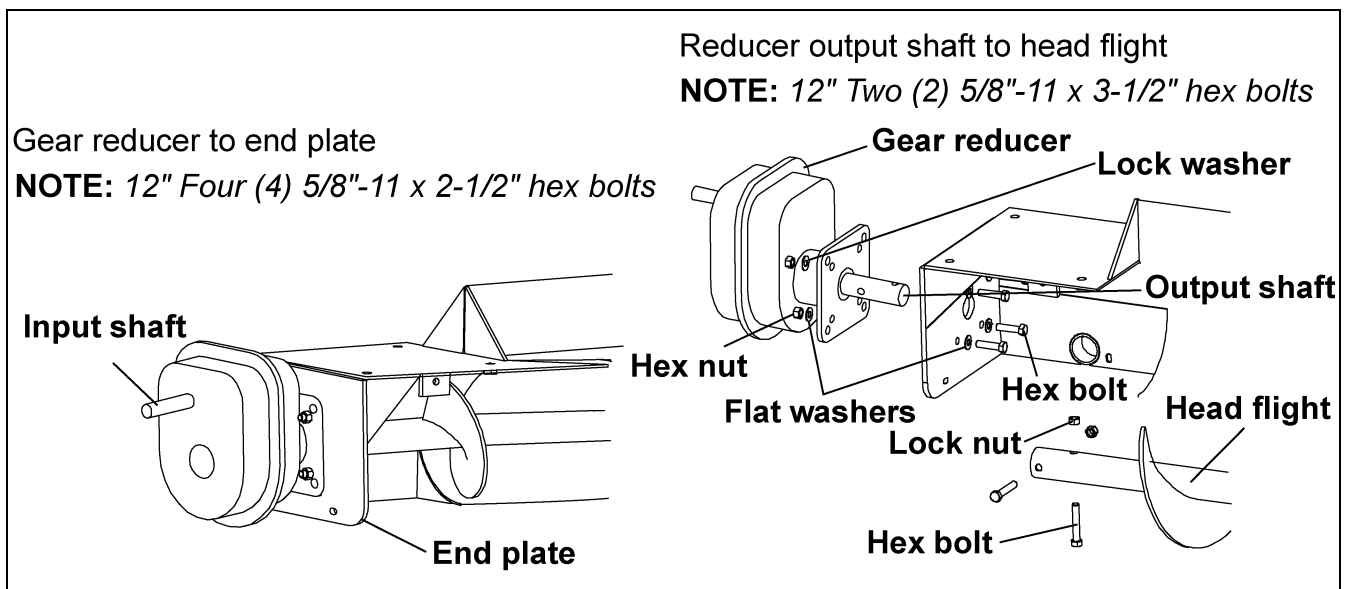

Figure 5G

CAUTION

The gear reducer is NOT filled with oil from the factory. For gear reducer specifications and oil fill recommendations, refer to the lubrication section on [Page 64](#) of this manual.

Drive Axle Assembly and Bearing Support

- A. Loosen set screws on bearings.
- B. Replace standard grease zerks with 90° grease zerks on both bearings. Make sure the 90° grease zerk is turned as shown in [Figure 5H](#), so the zerks are accessible from the center of the tractor drive stand.

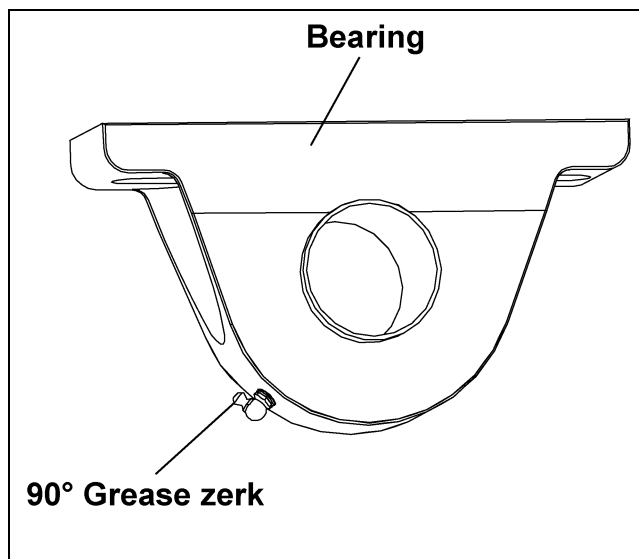

Figure 5H

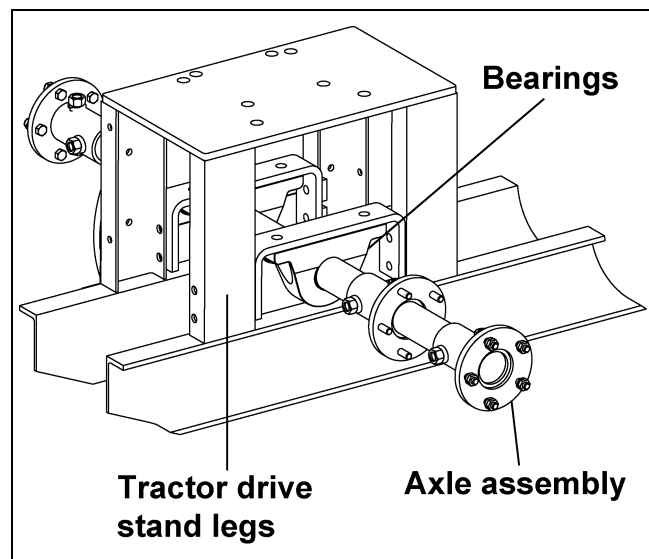

Figure 5I

- C. Slide the axle assembly between the legs of the tractor drive stand as shown in [Figure 5I](#).
- D. Rotate the pillow block bearings until the bases are facing up. ([See Figure 5I](#).)

5. Assembly

E. Bolt the bearing support brackets to the legs of the tractor drive stand using 1/2" x 1-3/4" bolts, 1/2" lock washers, 1/2" bevel washers and 1/2" hex nuts. (See Figure 5J.)

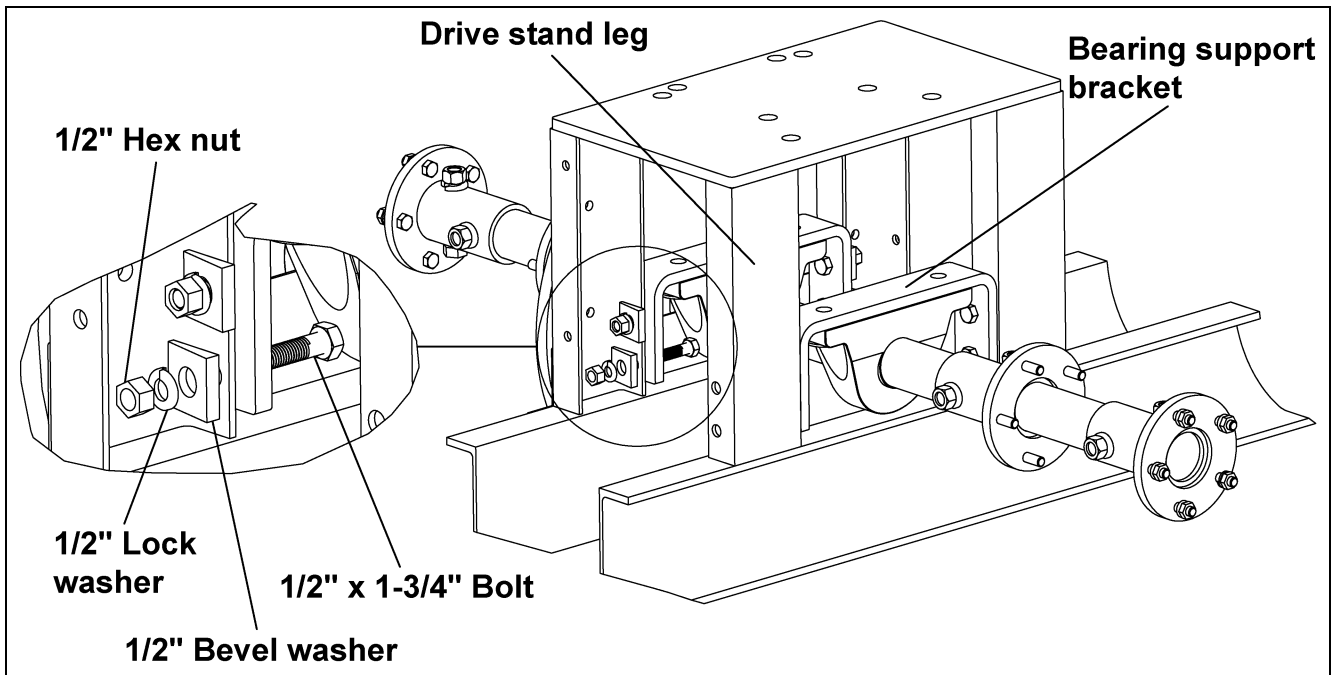

Figure 5J

F. Attach pillow block bearings to the bearing support brackets using 5/8" x 2-1/2" bolts, 5/8" lock and flat washers and 5/8" hex nuts. (See Figure 5K.)

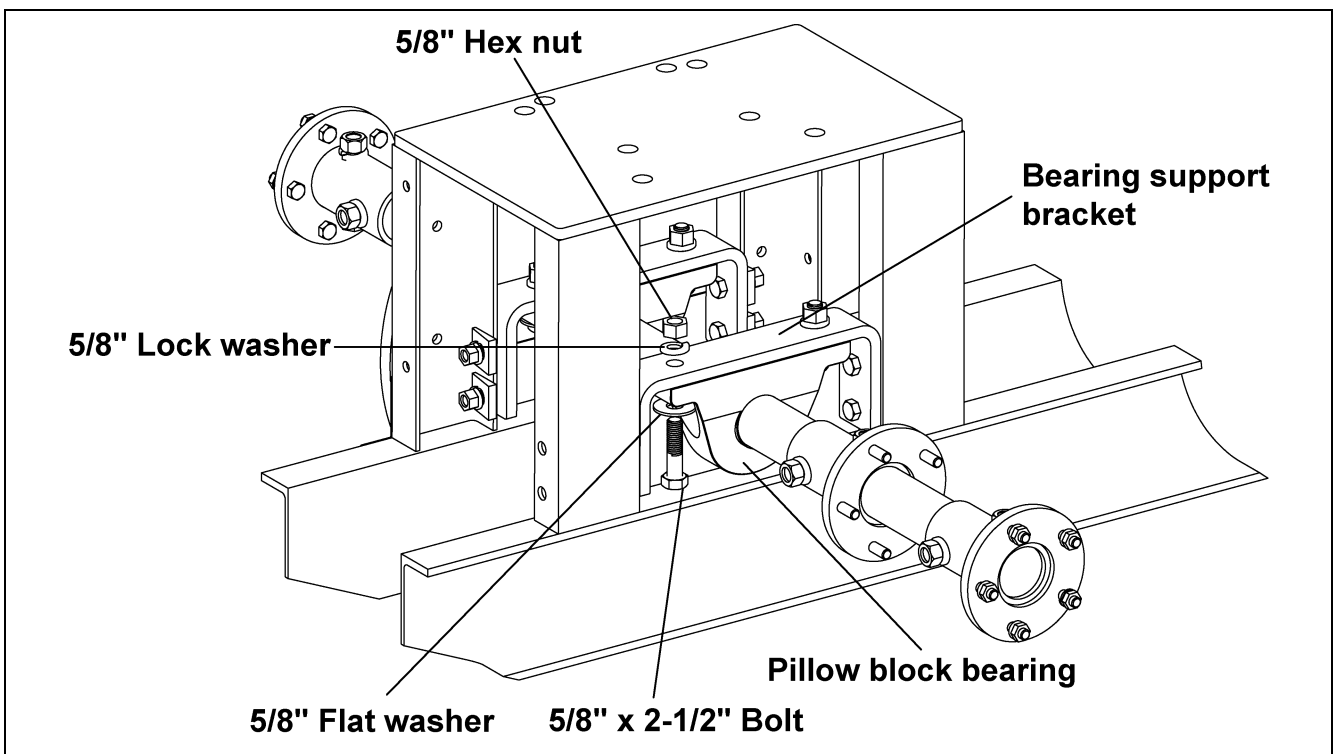

Figure 5K

G. Tighten set screws on pillow block bearings.

H. Tighten all hardware.

Install Reducer Mounting Plate and Reducer

- A. Attach the C-face reducer to the mounting plate using four (4) 5/8"-11 x 1-1/4" hex bolts and lock washers. (See Figure 5L.)
- B. Fasten the reducer mounting plate to the tail section plate using four (4) 5/8"-11 x 6" all-thread rods and sixteen (16) hex nuts. Adjust the mounting plate as close as possible to the tail section plate.



The gear reducer is NOT filled with oil from the factory. For gear reducer specifications and oil fill recommendations, refer to the Owner's manual supplied with the reducer or the lubrication information in the lubrication section on Page 64 of this manual.

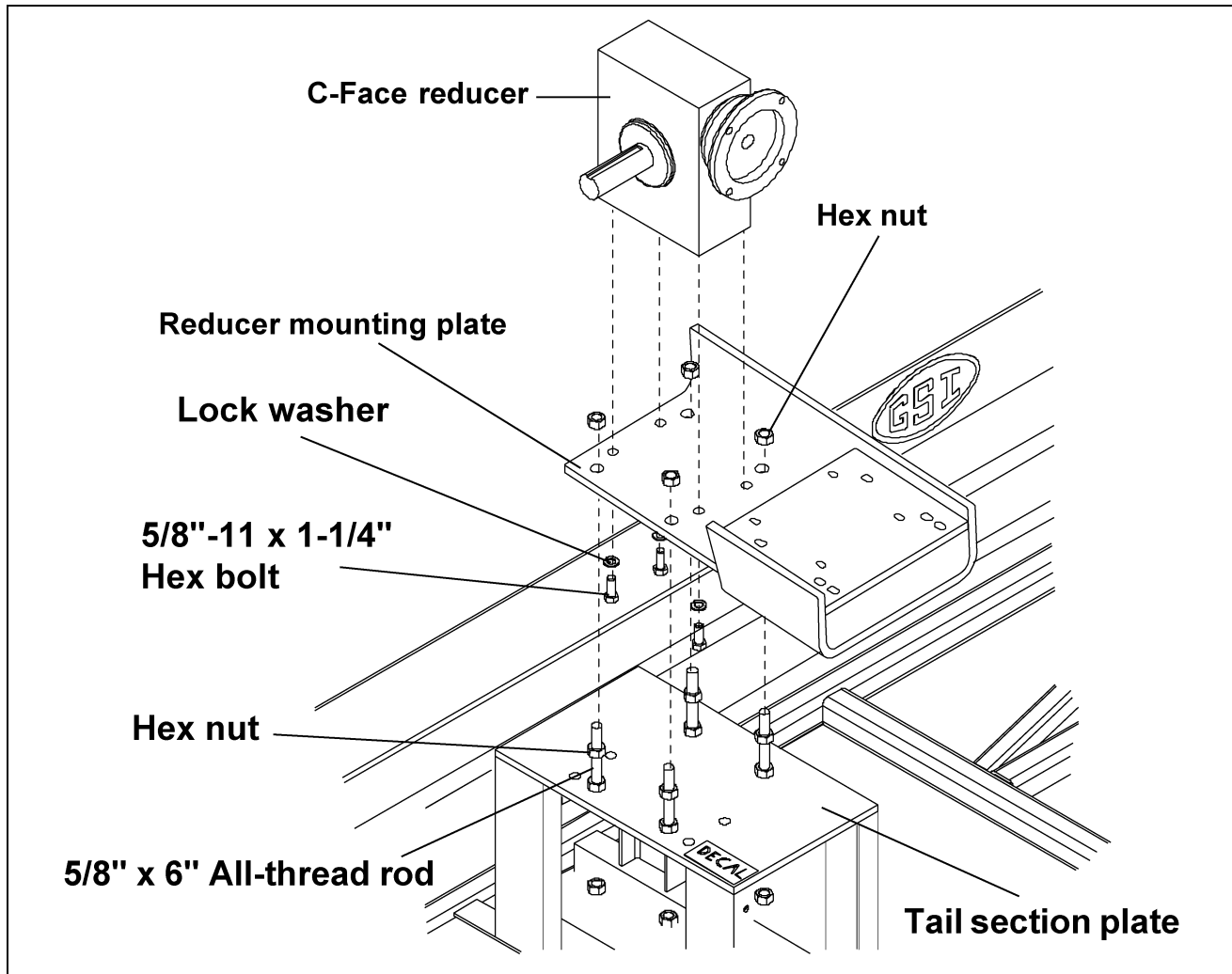

Figure 5L



The tractor drive gear reducer has a drain plug in the bottom of the housing. Make sure the drain plug is flush or slightly under the surface of the mounting face. If it is not, the plug will not allow the reducer to set flat on the mounting plate and could cause the motor to seize.

THIS TYPE OF DAMAGE IS NOT COVERED BY THE WARRANTY.

Key Alignment



All keys should be parallel to the drive shaft. If the key is not straight (parallel) the gearbox quill sleeve will crack.

THIS TYPE OF DAMAGE IS NOT COVERED BY WARRANTY.

- A. Place key in keyway on drive shaft.
- B. Make sure key is flat (parallel to drive shaft) in keyway as in [Figure 5M_1](#) and [Figure 5M_2](#). **NOT** like [Figure 5M_3](#).

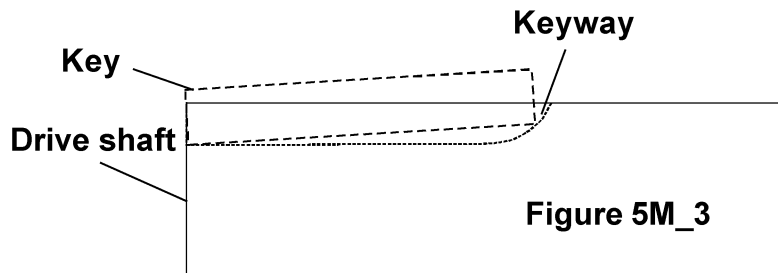
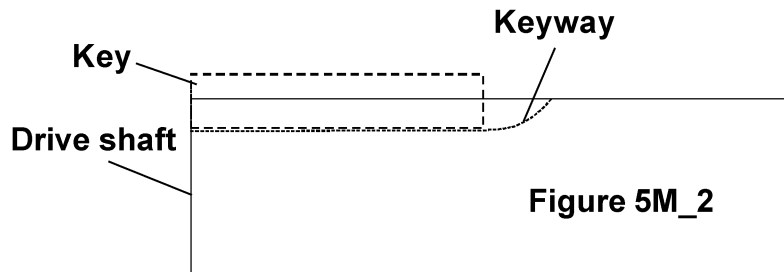
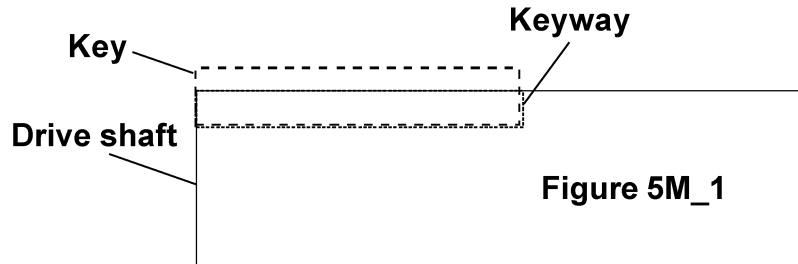

Figure 5M

C. Line up keyway on shaft with keyway on reducer and insert shaft into motor. (See Figure 5N.)

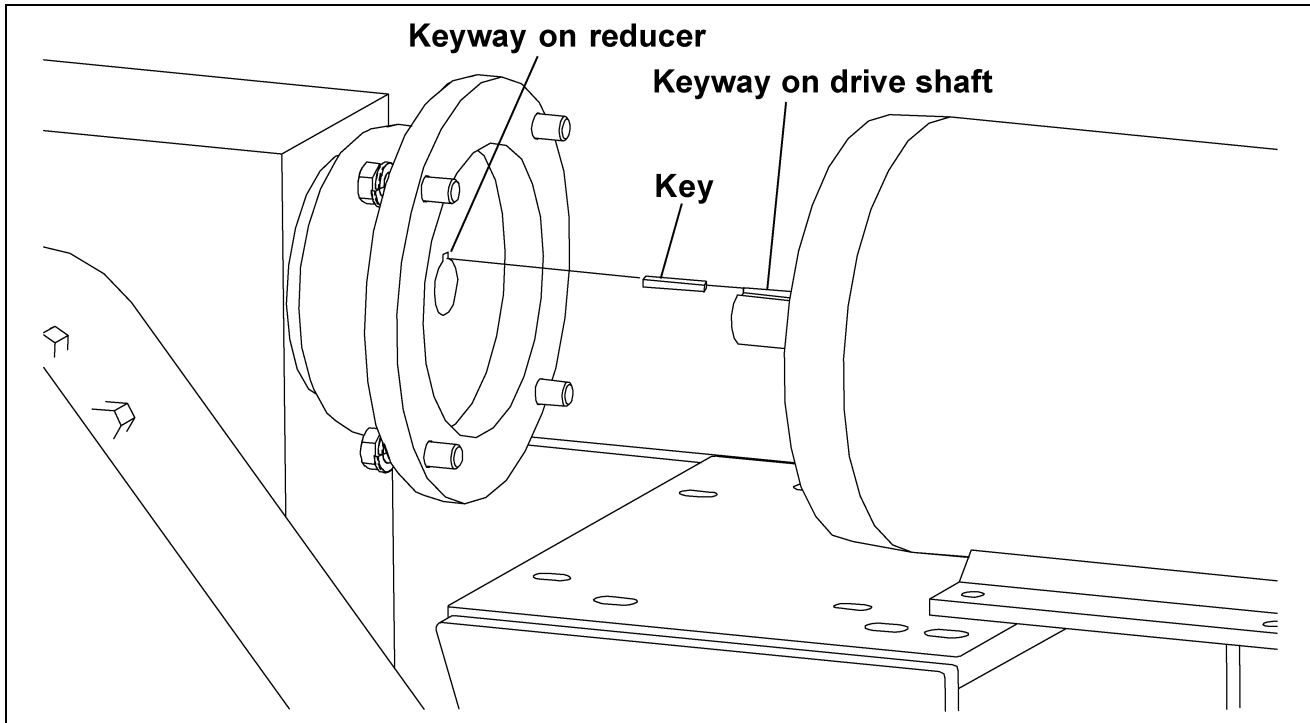

Figure 5N

Install Tractor Drive Motor

A. Bolt the C-face motor to the reducer using hex bolts, lock washers and a key. (See Figure 5O on Page 32.) (See the note on Page 32 for bolt size.)



Do not use the motor mounting bolts to pull the motor down to the motor mount plate. Instead, add shims GC09838 between the motor feet and the motor mount plate to fill any gap. If these shims are not used as required, the motor front bearing may be pushed out of alignment and the motor will lock up. If the gap seems unusually large, over 1/4", check to make sure the gear reducer is setting flat on its mounting base. The tractor drive gear reducer has a drain plug in the bottom of the housing. Make sure the drain plug is flush or slightly under the surface of the mounting face. If it is not, the plug will not allow the reducer to set flat on its mounting plate, causing damage to the motor.

THIS TYPE OF DAMAGE IS NOT COVERED BY WARRANTY.

5. Assembly

NOTE: 182TC Frame Four (4) 1/2"-13 x 1-1/4" hex bolts and 1/4" x 1/4" x 1" key

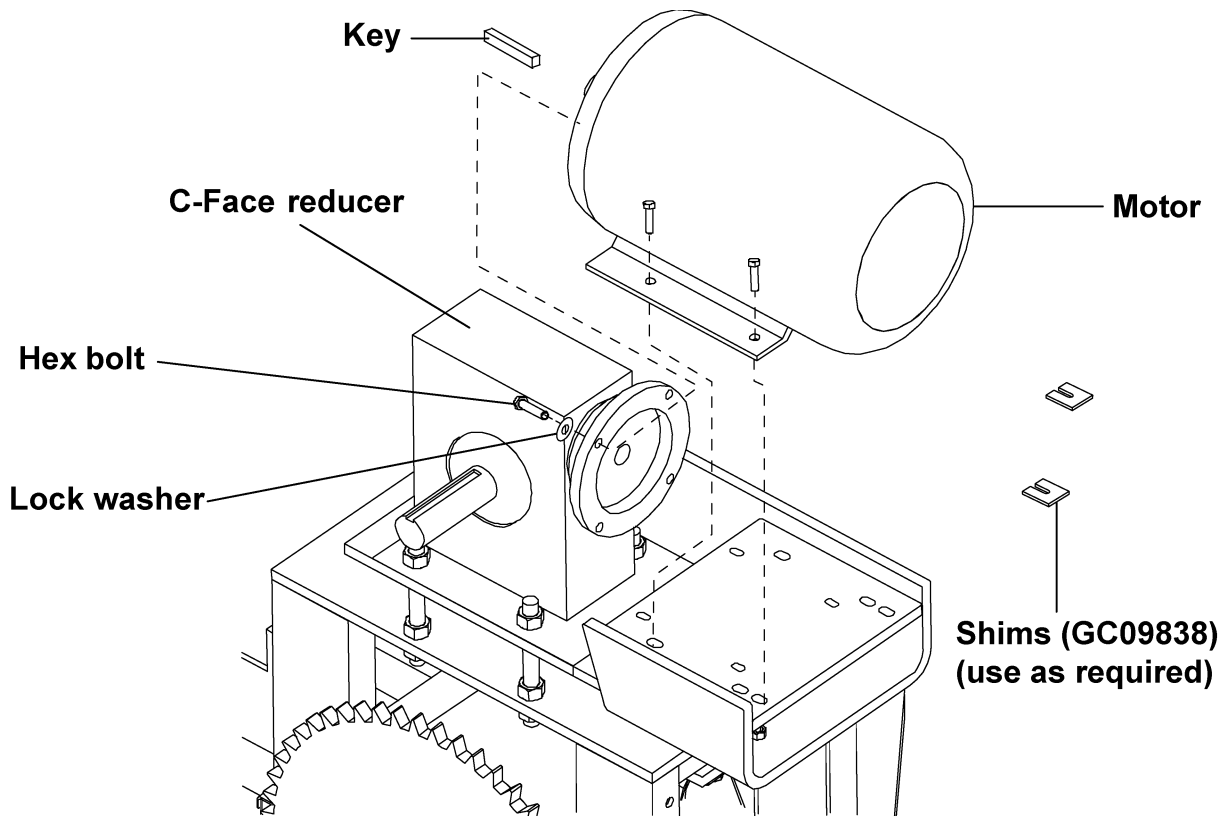

Figure 50

Guard Assembly

- A. Attach the guard plate to the tractor drive stand legs using 3/8" bolts and nuts before attaching the drive sprocket. (See [Figure 5P on Page 33.](#))
- B. Slide the fourteen (14) tooth (teeth N/S) drive sprocket, bushing and key (see [key chart on Page 33 for the size key](#)) onto the output shaft of the reducer, make sure both sprockets line up. (See [Figure 5P and Figure 5P_A on Page 33.](#))
- C. Assemble the bottom chain guard trap to the bottom chain guard weldment using 1/2" x 3" HHCS bolts, 1/2" split lock washers and 1/2" hex nuts. (See [Figure 5P on Page 33.](#))
- D. Attach bottom chain guard weldment to tractor drive stand using 3/8" x 1-1/4" HHCS bolts, 3/8" split lock washers and 3/8" hex nuts. (See [Figure 5P on Page 33.](#))
- E. Attach top chain guard assembly to tractor drive stand using 3/8" x 1" bolts, 3/8" split lock washers and 3/8" hex nuts. (See [Figure 5P on Page 33.](#))

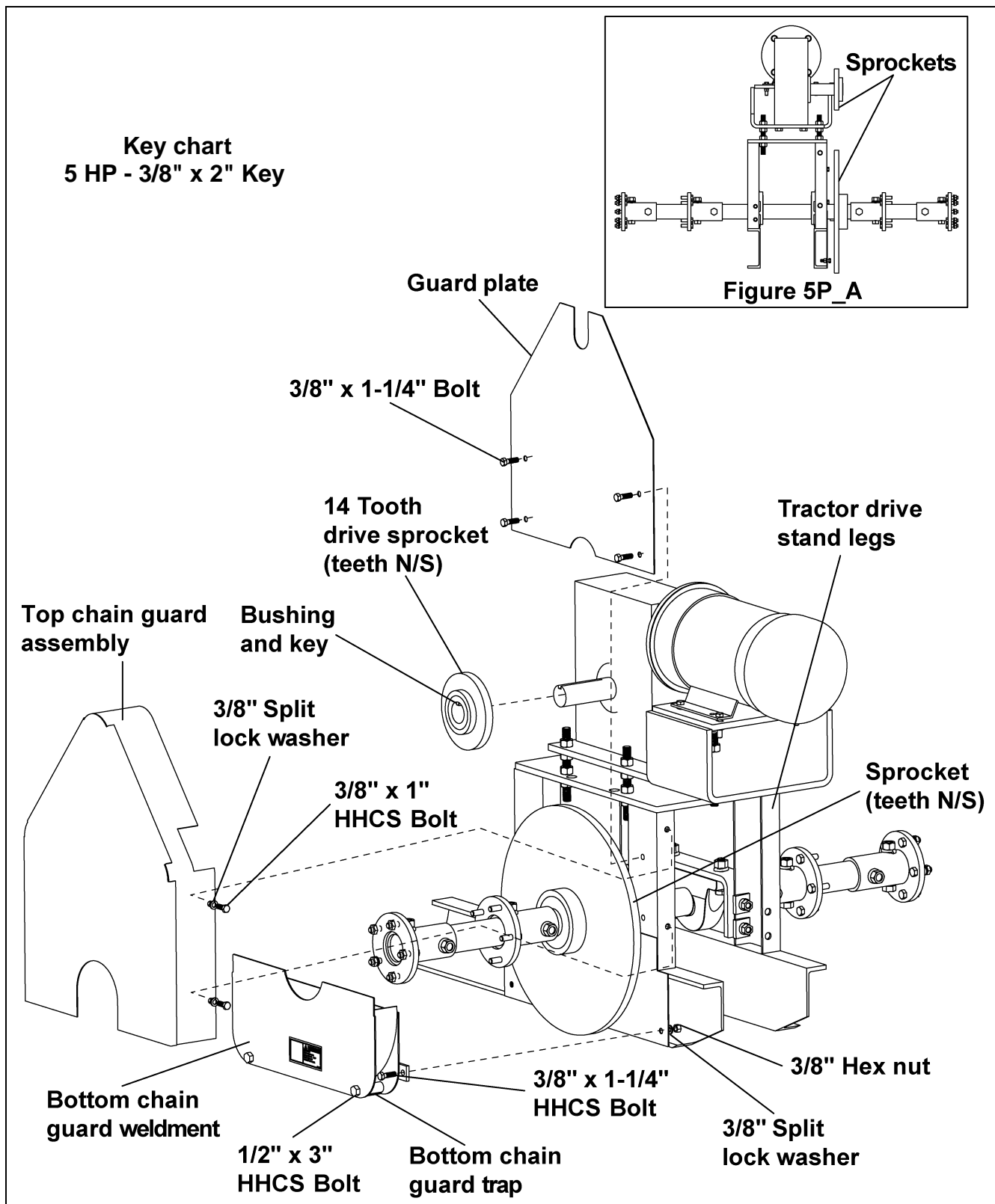

Figure 5P



Wedging forces in the bushing saw slot, such as that exerted by a narrow edged regular screw driver, may damage or break the bushing. This damage would not be covered under the GSI warranty.

Tractor Wheel Assembly

A. Assemble the tires to the drive axle assembly using twenty (20) 7/16" lock washers and hex nuts. (See Figure 5Q.)

NOTE: Tires go on backwards as shown in Figure 5Q.

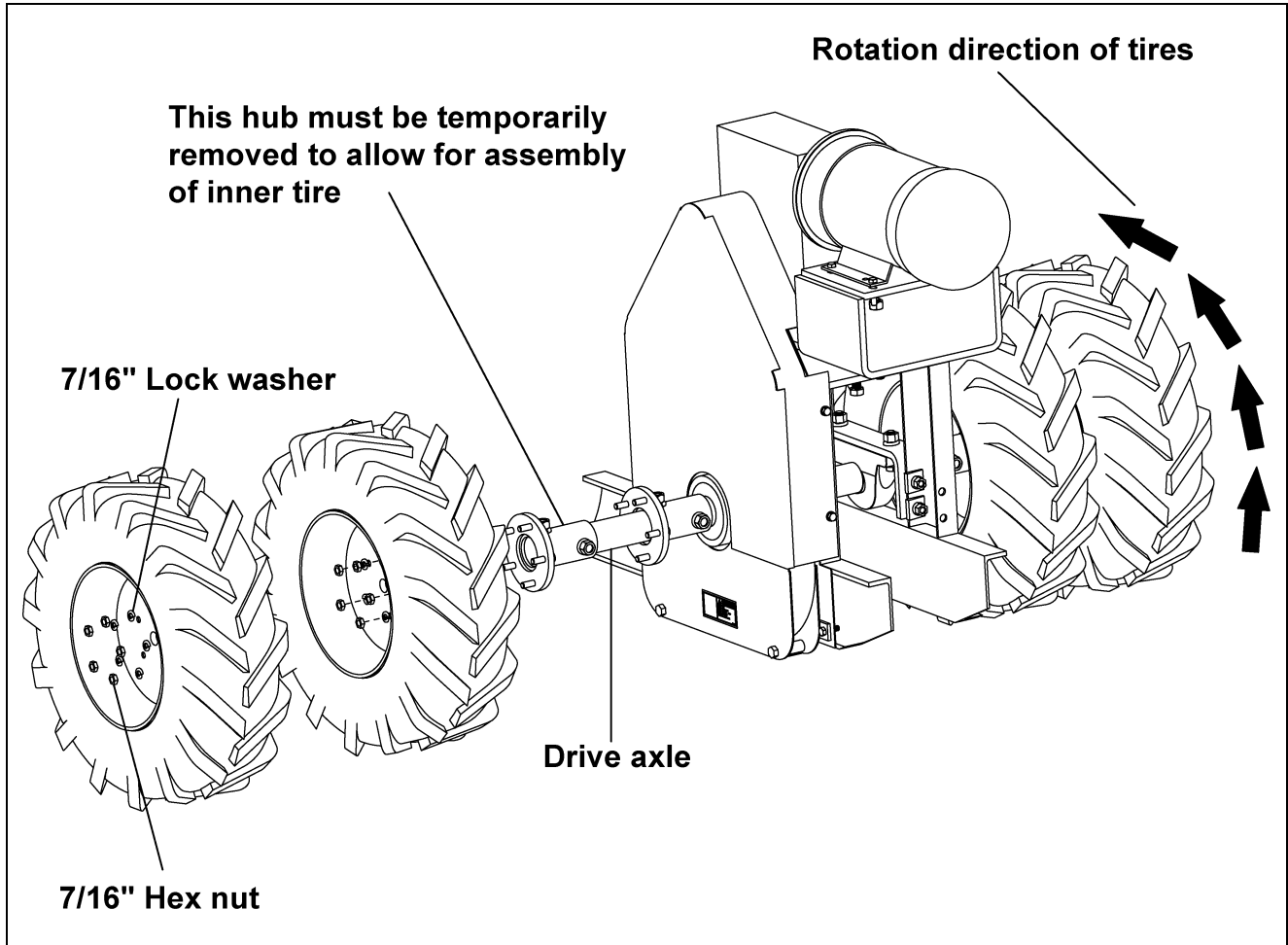

Figure 5Q

Weight Placement

- A. Place an equal number of weights on each side of the drive assembly on the six inch (6") channels that are welded to the tail section.



Use proper lifting procedures and equipment when lifting the weights. Each weight weighs 175 pounds.

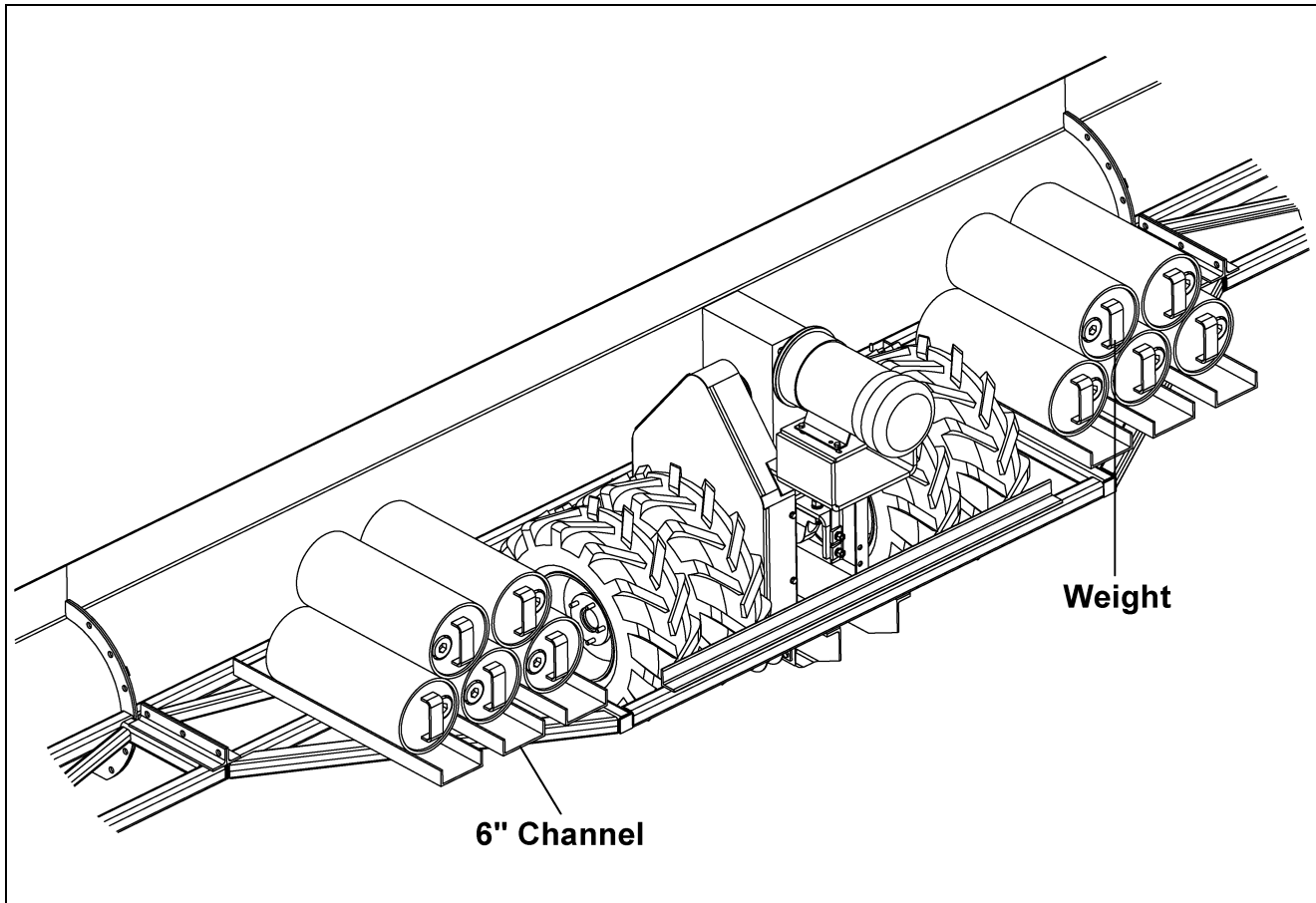

Figure 5R

Channel Extension Kit

- A. 131' and 135' Sweeps need an extension kit installed.
- B. Attach the center weight weldments to the adjustable center weight channel using eight (8) 1/2" x 1-1/4" bolts, split lock washers and hex nuts. The adjustable center weight has three (3) sets of holes for the center weight weldments to adjust the weights. (See Figure 5S.)

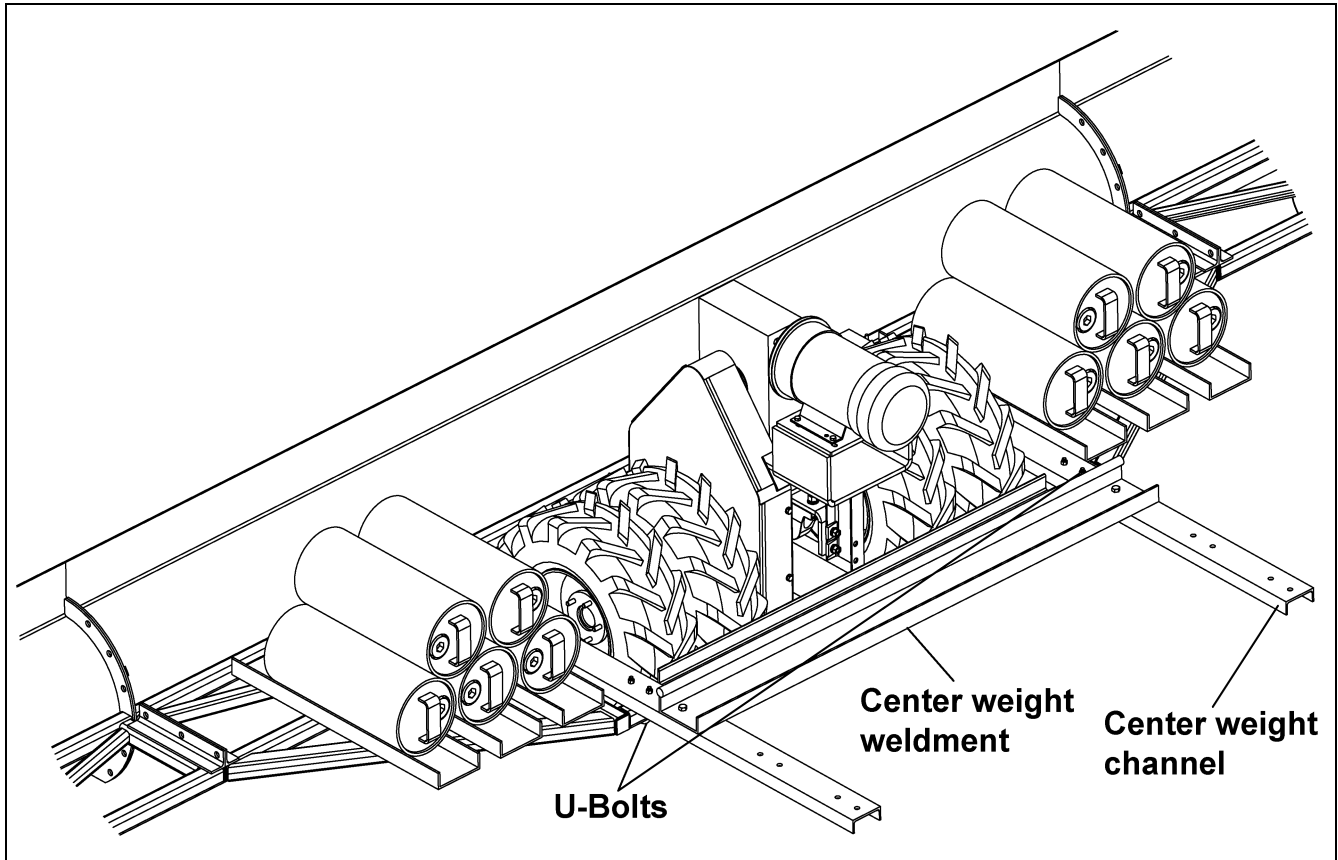

Figure 5S

- C. Place assembly on top of the back tail section, around the tires. The end of the adjustable center weight should be placed under the tail frame. (See Figure 5T.)

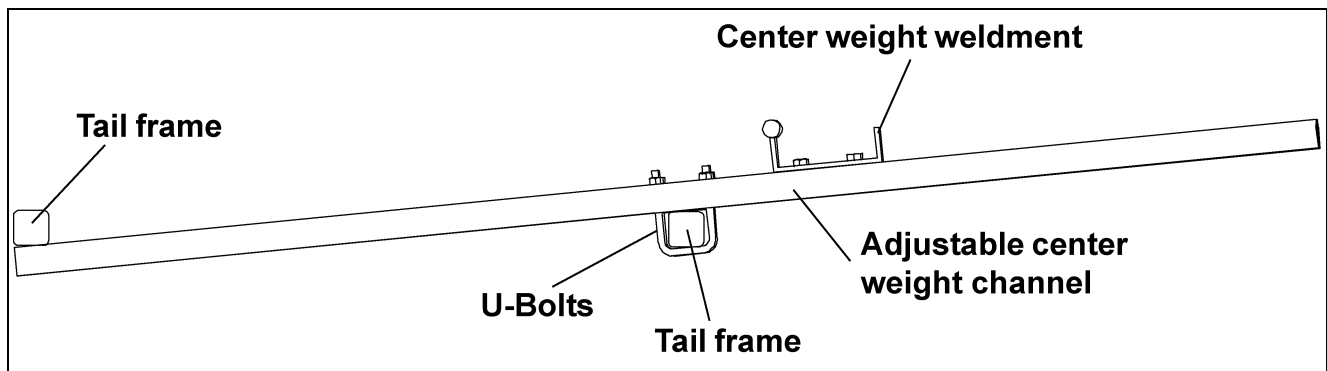

Figure 5T

- D. Fasten assembly to tail section using two (2) 3/8" x 2-7/16" U-bolts, four (4) 3/8" lock washers and four (4) 3/8" hex nuts.

Motor Jack and Base Assembly

- A. Attach the motor mount base assembly to the head section using four (4) 3/4" x 2" bolts, lock washers and hex nuts. (See Figure 5U.)
- B. Attach the motor jack assembly to the motor mount base assembly using four (4) 1/2"-13 x 1-1/2" bolts, 1/2" flat washers and 1/2" hex nuts.

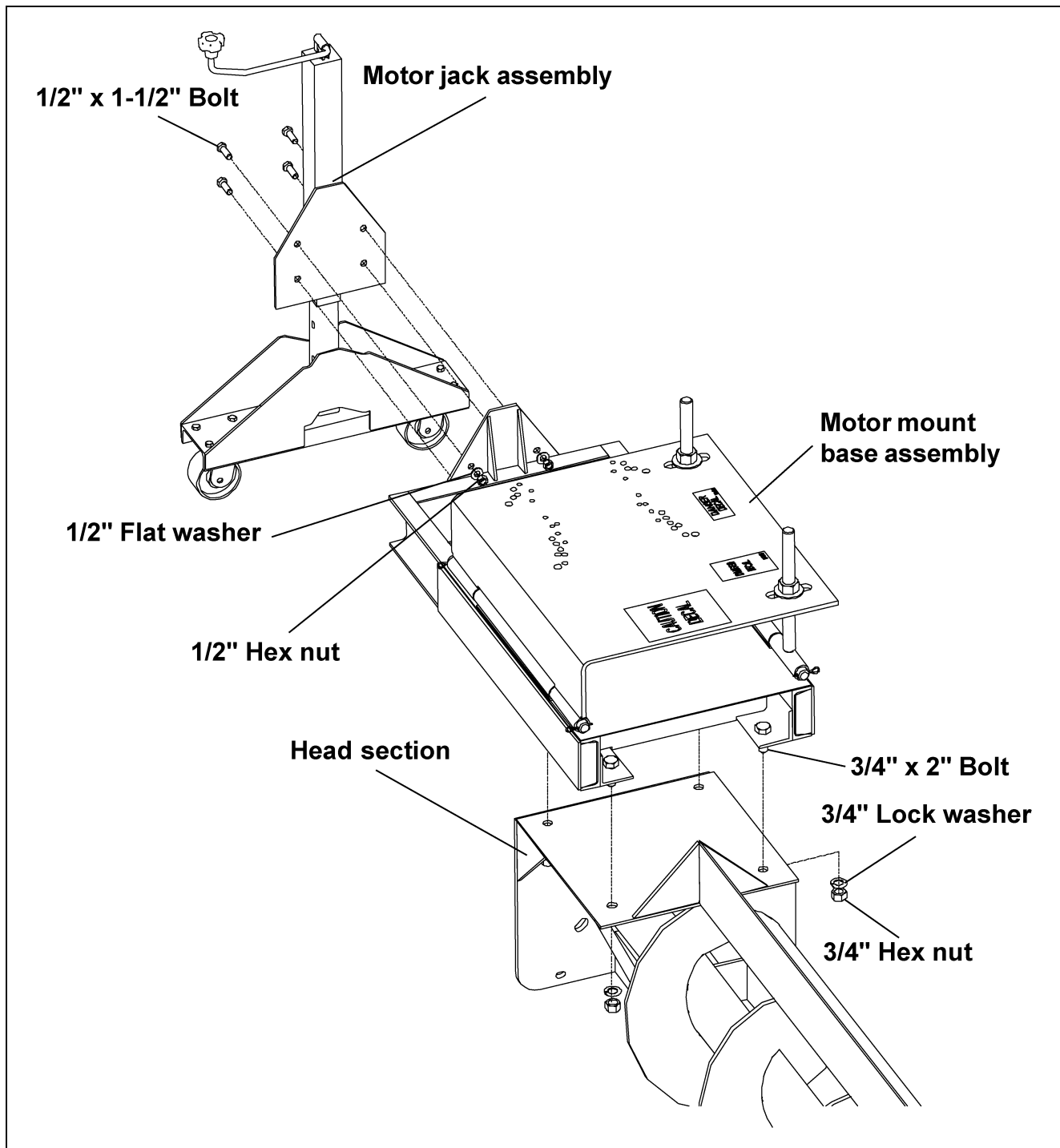

Figure 5U

Motor Installation

- A. Level the top plate assembly by adjusting the 1" nuts and washers on the adjustment rods. (See Figure 5V.)
- B. Line up the end face of the shafts as closely as possible before bolting motor to mounting plate. (See Figure 5V-A.)

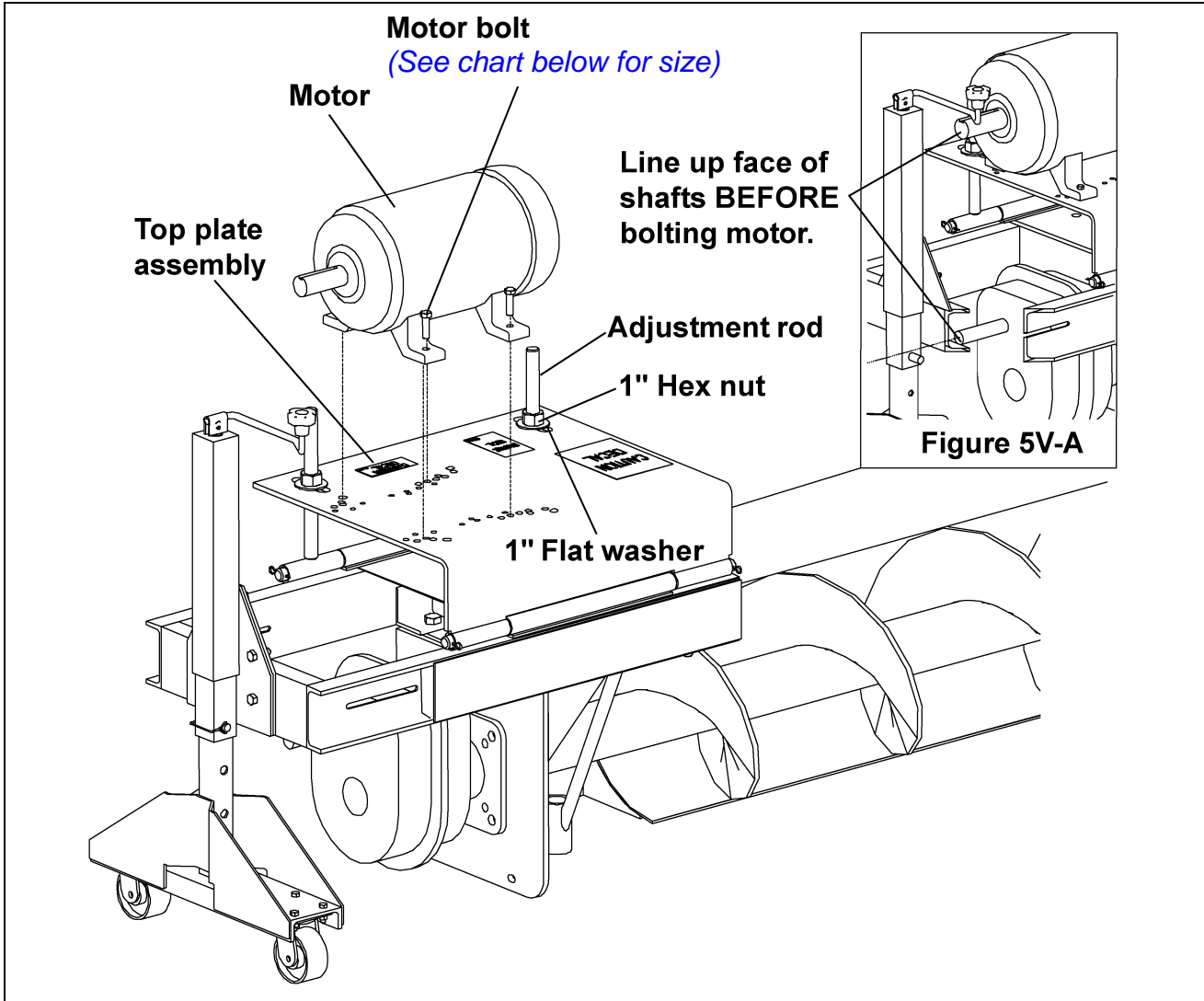

Figure 5V

- C. Fasten the motor to the motor mount using hex bolts, lock washers and hex nuts. (See Motor Bolt Chart for bolt sizes.)

Motor Bolt Chart		
Motor Size	Hex Bolt Size	Qty
213T	3/8"-16 x 1-1/4"	4
215T	3/8"-16 x 1-1/4"	4
254T	1/2"-13 x 1-3/4"	4
256T	1/2"-13 x 1-3/4"	4
284T	1/2"-13 x 1-3/4"	4
286T	1/2"-13 x 1-3/4"	4

Sheave Installation



WARNING To ensure that the drive is not unexpectedly started, turn OFF and lock out the power source before proceeding. Failure to observe these precautions could result in bodily injury.



CAUTION Wedging forces in the bushing saw slot, such as that exerted by a narrow edged regular screw driver, may damage or break the bushing. This damage would not be covered under the GSI warranty.

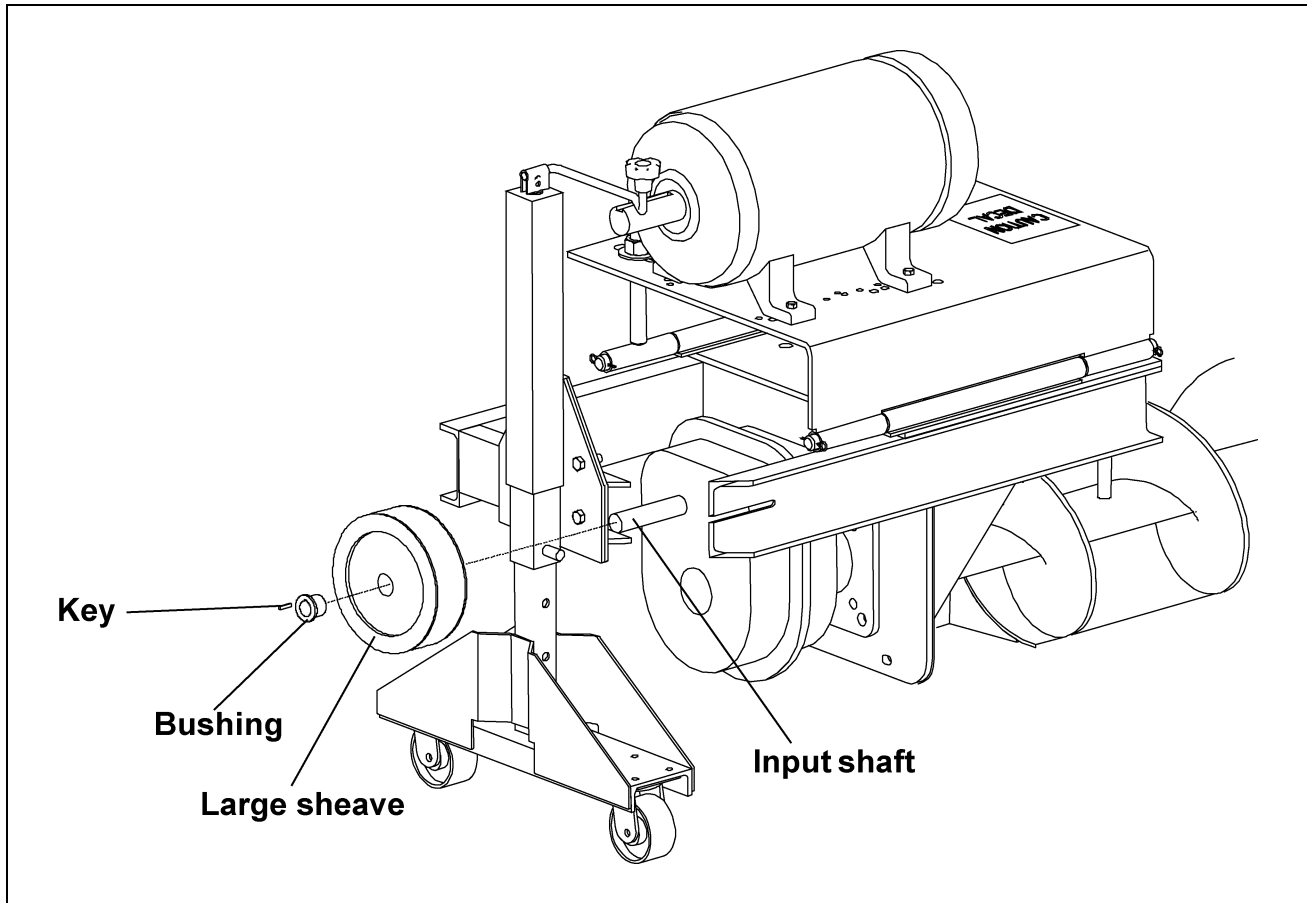

Figure 5W

- A. Loosely bolt the bushing and large sheave together with the screws provided with the bushing.
- B. Slide the bushing and large sheave onto the auger gear reducer input shaft with a key.
(See [Figure 5W.](#))
- C. Loosely bolt the bushing and small sheave together with the screws provided with the bushing.

5. Assembly

D. Slide the bushing and small sheave onto the motor shaft with a key. (See Figure 5X.)

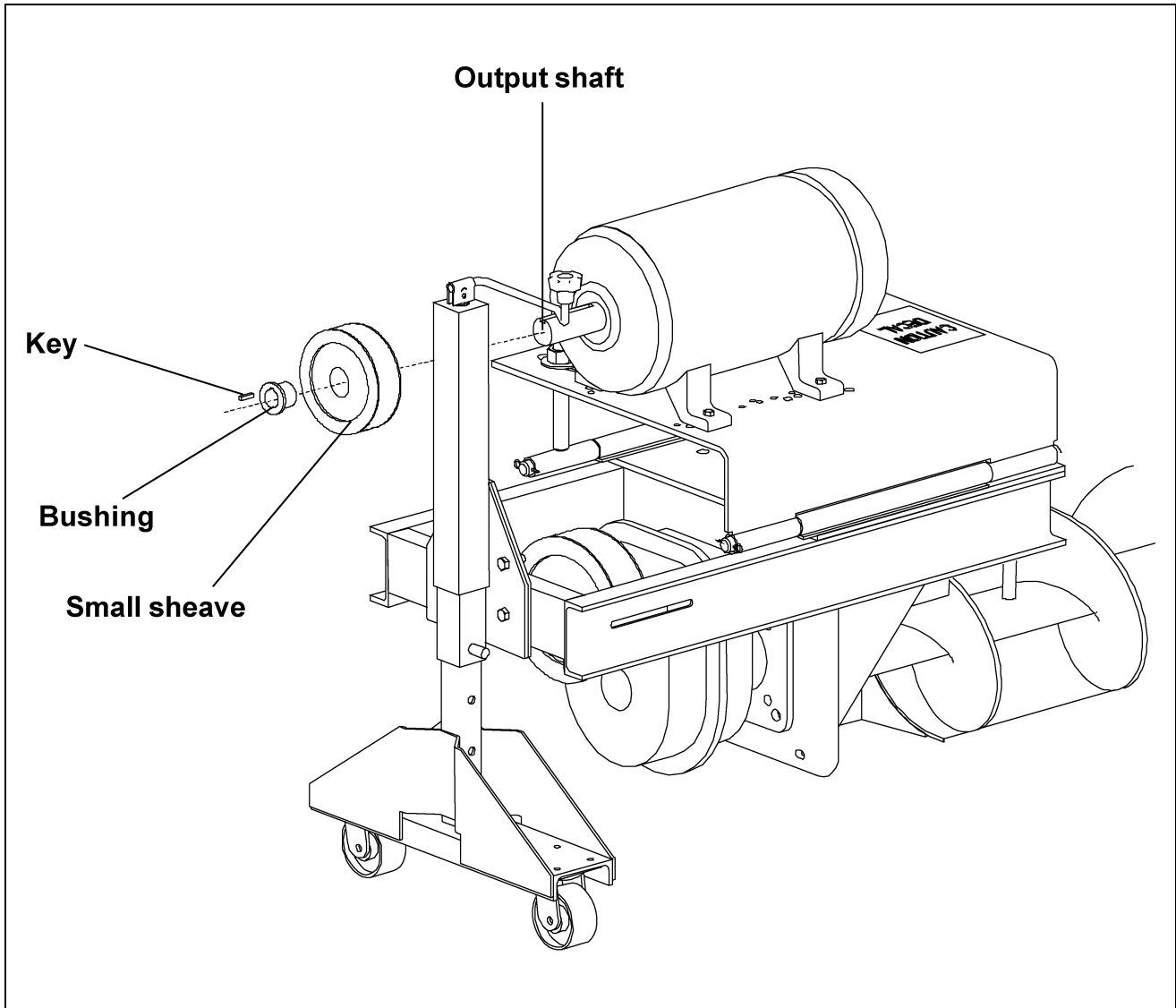

Figure 5X

E. Align the sheaves with a straight edge to assure proper alignment and tighten the screws on the bushings. (See Figure 5X.)

F. Carefully install the belts onto the large and small sheaves. (See Figure 5Y on Page 41.)

NOTE: *Adjust the hex nuts on the motor mount adjustment rod to attain correct belt tension while making sure the motor mount is level on both rods. The motor mount must be parallel to the auger screw to allow for proper sheave alignment.*

G. Loosely bolt the bottom belt guard to the motor mount using four (4) 3/8"-16 x 1" hex bolts, flat washers and lock washers. (See [Figure 5Y](#).)

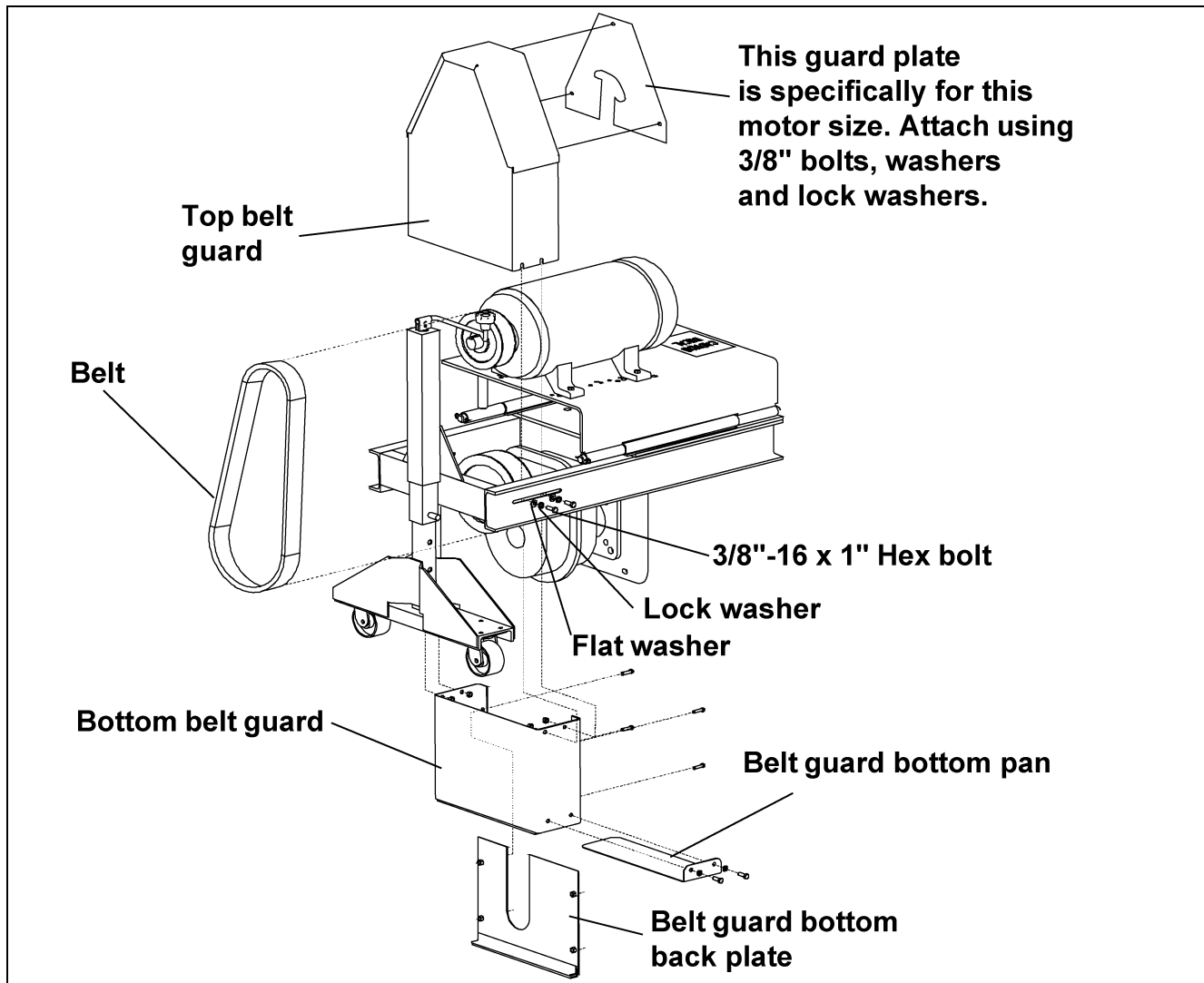

Figure 5Y

H. Slide the top belt guard over the bottom belt guard as shown in [Figure 5Y](#) and tighten bolts.

I. Install belt guard bottom back plate.

J. Slide belt guard bottom pan and bolt into place.

Electrical Assembly



All electrical wiring and service work must be performed by a qualified electrician and must meet all state and local electrical codes.

NOTE: See [Chart below](#) for the correct size of conduit with the corresponding sweep size.

- A. Place the 3/4" rigid conduits in order starting with the head section and working towards the tail or extension section.
- B. Connect the rigid conduit together using one 3/4" conduit coupling between each piece of conduit. (See [Figure 5Z.](#))

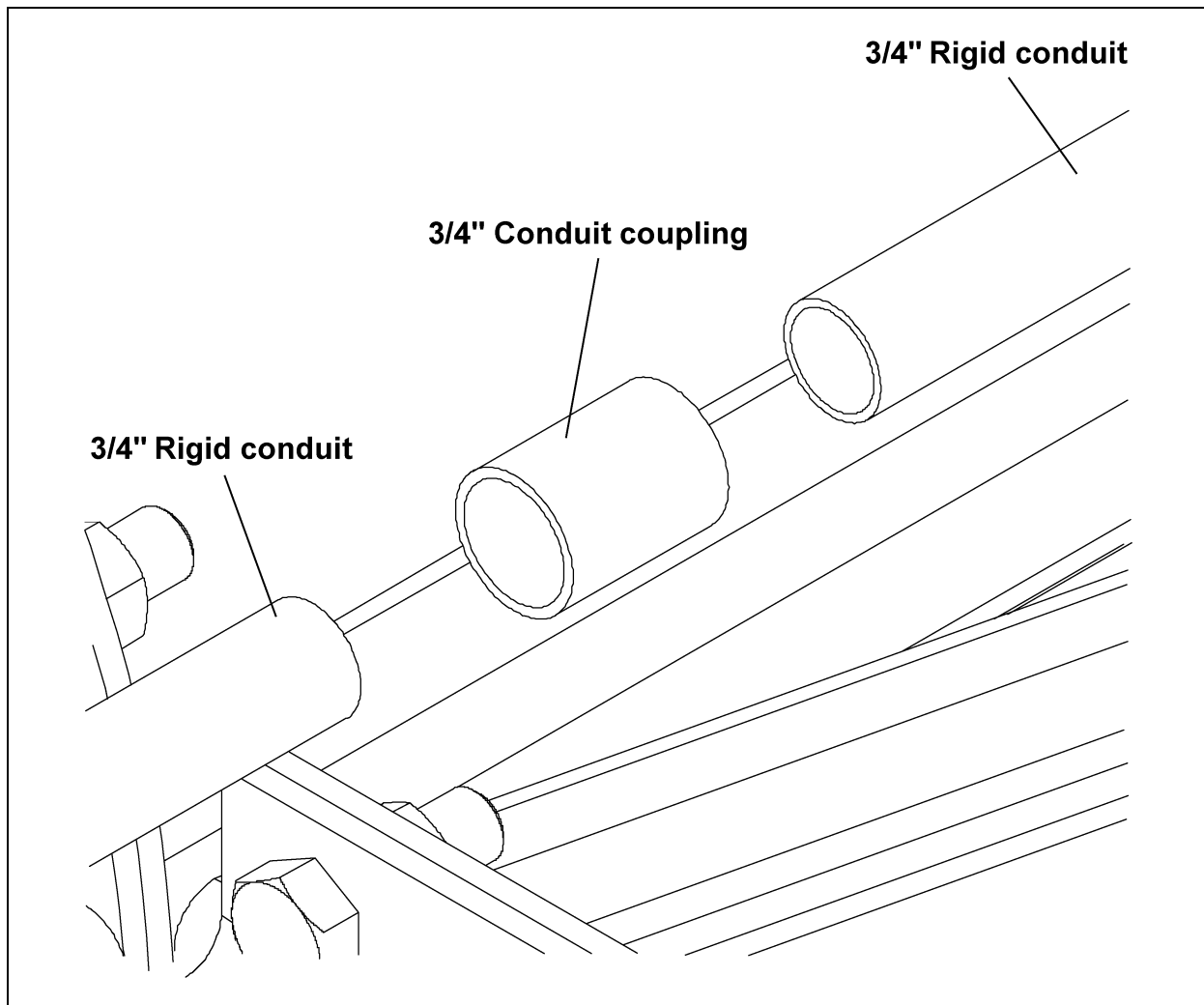

Figure 5Z

Sweep Section Conduit Sizes

Bin Diameter	10' Conduit Pieces	Other Pieces
131'	4	1 @ 5'
135'	4	1 @ 7'

- C. Connect the 3/4" x 48" liquid-tight flex conduit to the drive end of the 3/4" rigid conduit using one 3/4" conduit coupling and one 3/4" liquid-tight flex conduit coupling. (See Figure 5AA.)
1. Thread a 3/4" conduit coupling onto the 3/4" rigid conduit. (See Figure 5AA.)
 2. Thread a 3/4" flex conduit coupling body onto the 3/4" conduit coupling. (See Figure 5AA.)
 3. Slide a 3/4" flex conduit coupling cap onto the 3/4" flex conduit followed by a plastic ring. (See Figure 5AA.)
 4. Thread a steel ring into the 3/4" flex conduit. (See Figure 5AA.)
 5. Thread the 3/4" flex conduit coupling cap onto the 3/4" flex conduit coupling body. (See Figure 5AA.)

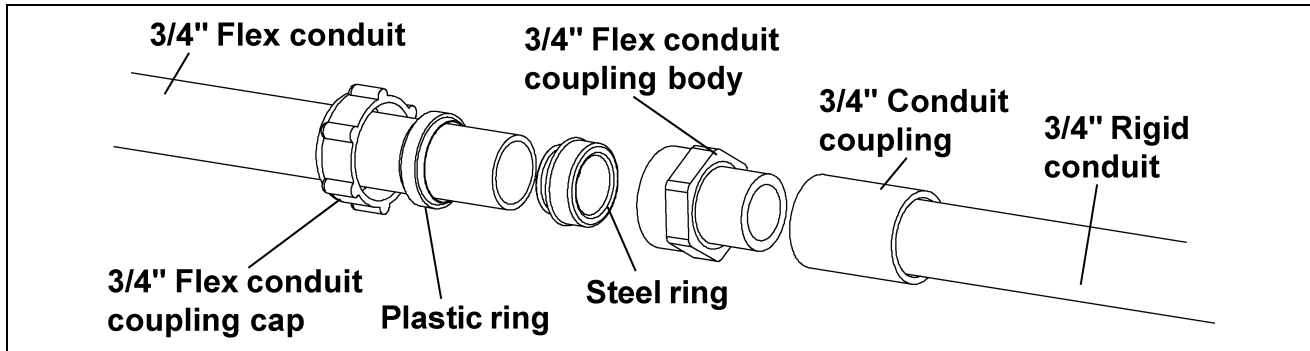

Figure 5AA

- D. Attach the 3/4" x 12" liquid-tight flex conduit to the other end of the rigid conduit using one 3/4" conduit coupling and one 3/4" liquid-tight flex conduit coupling. (See Figure 5AB.)
- E. Connect the two (2) junction boxes together using the 1" x 4-3/4" conduit nipple. (See Figure 5AB.)
- F. Connect the 3/4" x 12" liquid-tight flex conduit to the left junction box using one 3/4" liquid-tight flex conduit coupling and one 1" to 3/4" reducer bushing. (See Figure 5AB.)
- G. Attach the 3/4" x 40" liquid-tight flex conduit to the right junction box using one 3/4" liquid-tight flex conduit coupling and one 1" to 3/4" reducer bushing. (See Figure 5AB.)

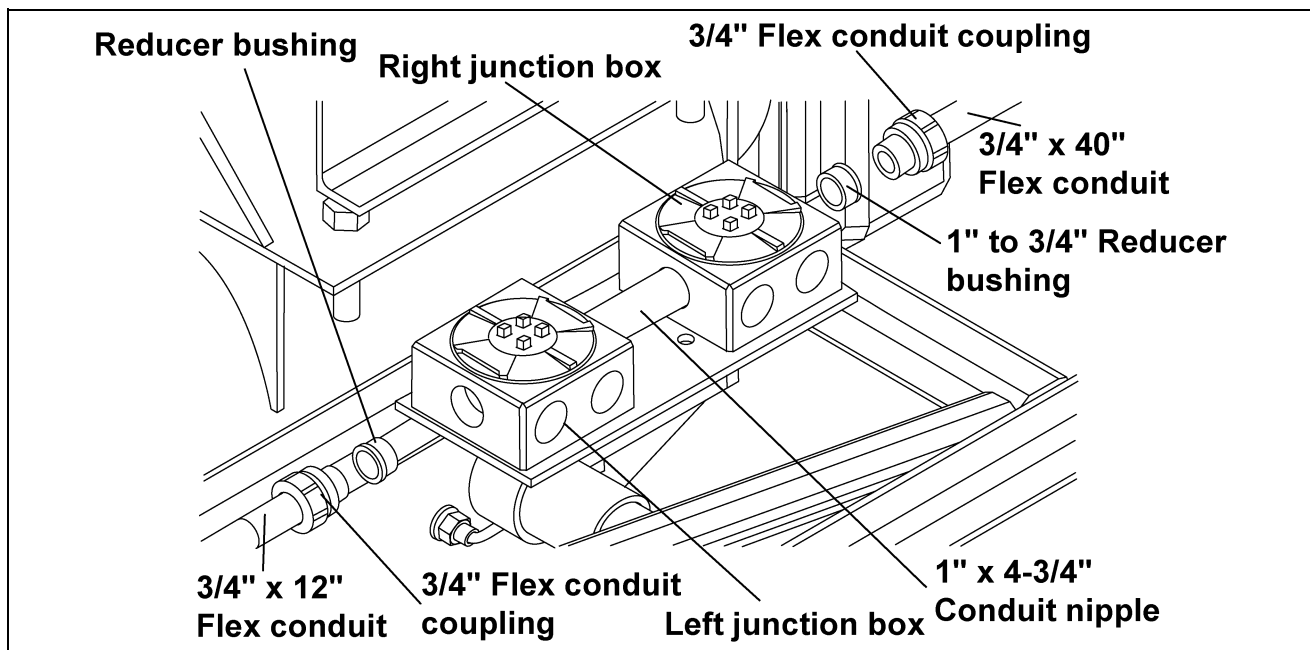

Figure 5AB

5. Assembly

- H. Feed each of the six (6) 14 AWG stranded wires through the 3/4" rigid conduit assembly and cut them off, leaving six inches (6") at both the left junction box and drive motor.
- I. Feed each of the six (6) 10 AWG stranded wires cord through the 3/4" x 40" liquid-tight flex conduit and cut four (4) of them off, leaving six inches (6") at both the right junction box and auger motor. Cut the 10 AWG blue and yellow wires longer so they can be connected to the 14 AWG blue and yellow wires in the left junction box.
- J. Place the 3/4" rigid conduit assembly onto the back frame of the sweep between the connecting angle and connecting flange.

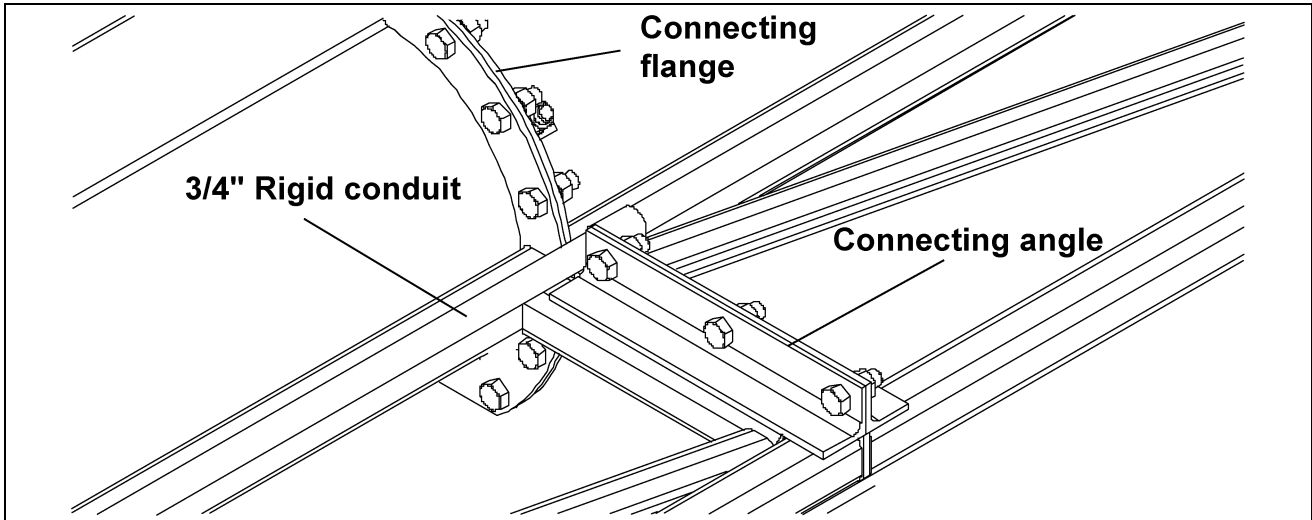

Figure 5AC

- K. Fasten the junction boxes to the mounting plate using two (2) 3/8"-16 x 1-3/8" U-bolts, four (4) lock washers and hex nuts.

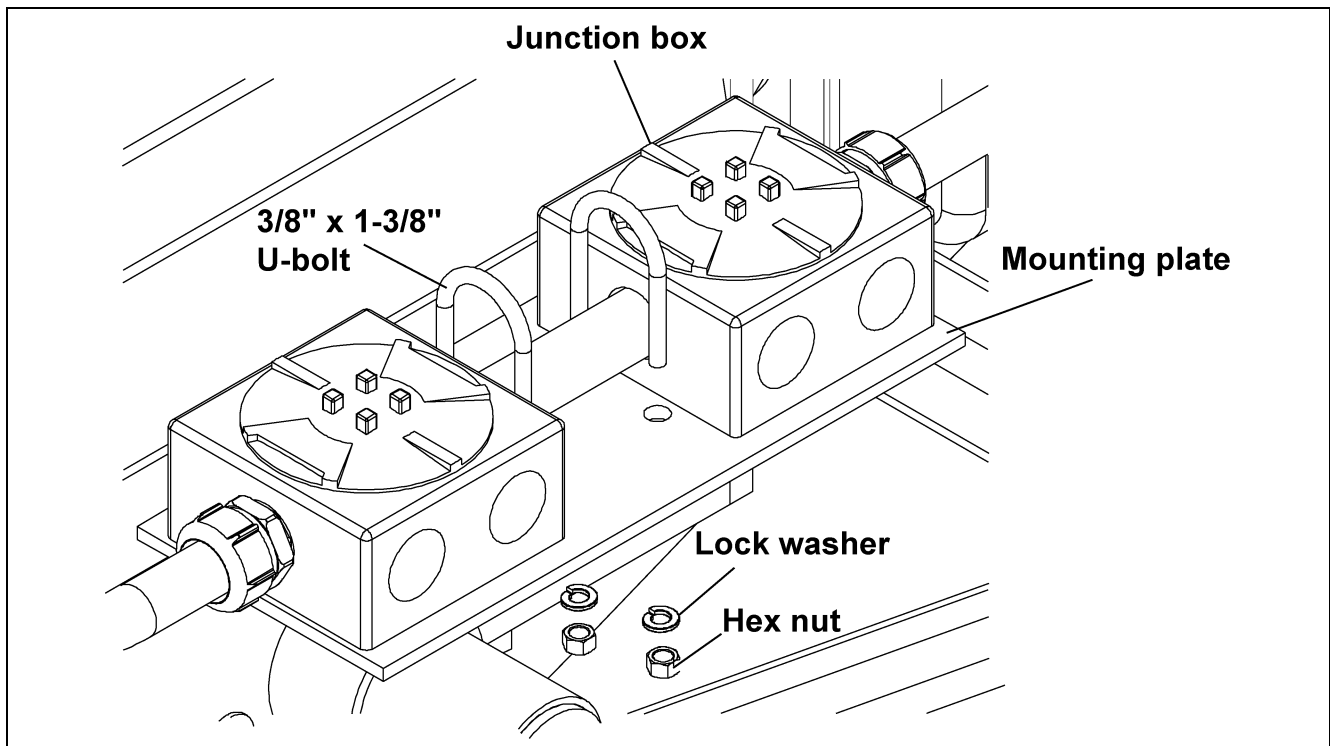

Figure 5AD

- L. Attach the 3/4" rigid conduit assembly to the sweep using the 5/16"-18 x 3/4" studs welded to the sweep using 1" conduit clamps, lock washers and hex nuts.
- M. Run the 14 AWG stranded wires into the drive motor and fasten the 3/4" x 48" liquid-tight flex conduit to the motor using one 3/4" liquid-tight flex conduit coupling. Some motors may require a reducer bushing not supplied with the sweep. Connect the leads as required.

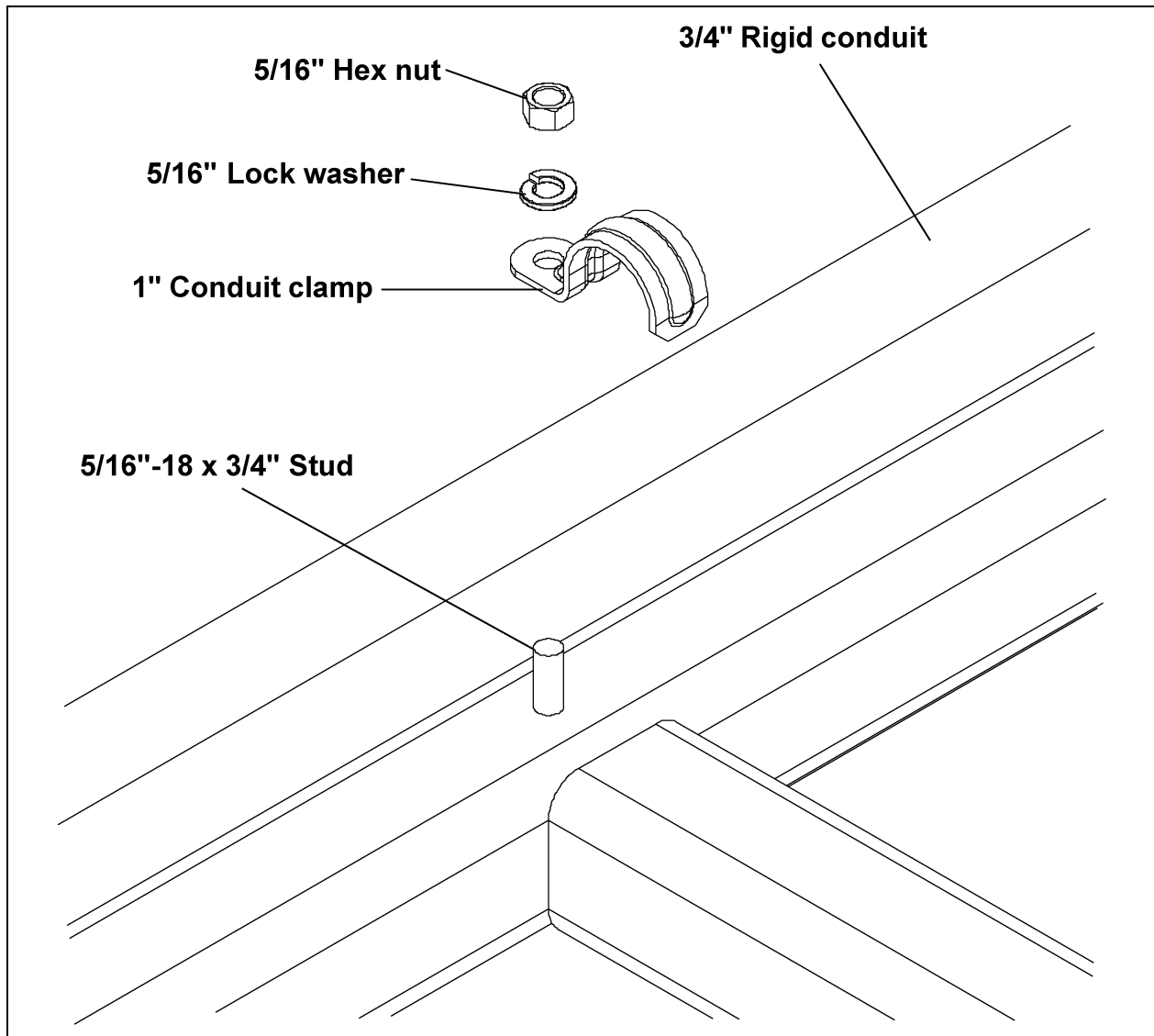

Figure 5AE

- N. Run the 10 AWG stranded wires into the auger motor and fasten the 3/4" x 40" liquid-tight flex conduit to the motor using one 3/4" liquid-tight flex conduit coupling. Some motors may require a reducer bushing not supplied with the sweep. Connect the leads as required.

5. Assembly

Jack Support Assembly

NOTE: Be sure to use the spanner bushings, supplied with the caster wheels, between the caster and the caster plate on each side.

Jack Support (See Figure 5AF below and Figure 5AG on Page 47.)

- A. Attach one caster wheel to the jack caster assembly using one 3/4" x 5-1/2" hex bolt, lock washer and hex nut.
- B. Locate the 2" x 2" x 12" tube to the right of each connecting angle and fasten the jack mount assembly to the sweep frame using one jack mount plate, four (4) 1/2"-13 x 3-3/4" hex bolts, lock washers and hex nuts.
- C. Attach the jack caster assembly to the jack assembly using one pin.
- D. Bolt the jack assembly to the jack mount assembly using four (4) 1/2"-13 x 2" hex bolts, lock washers and hex nuts.

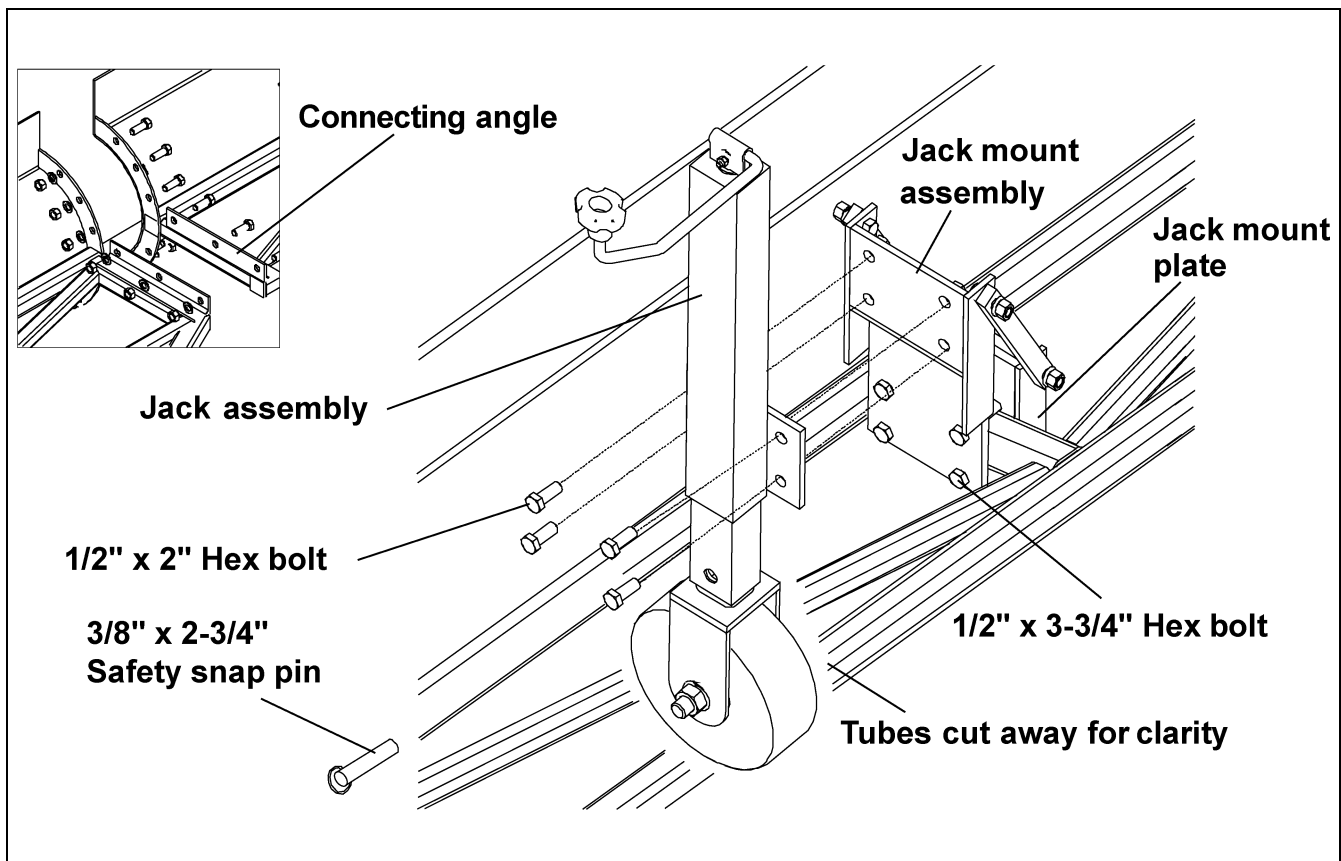

Figure 5AF Current Production Sweep Shown

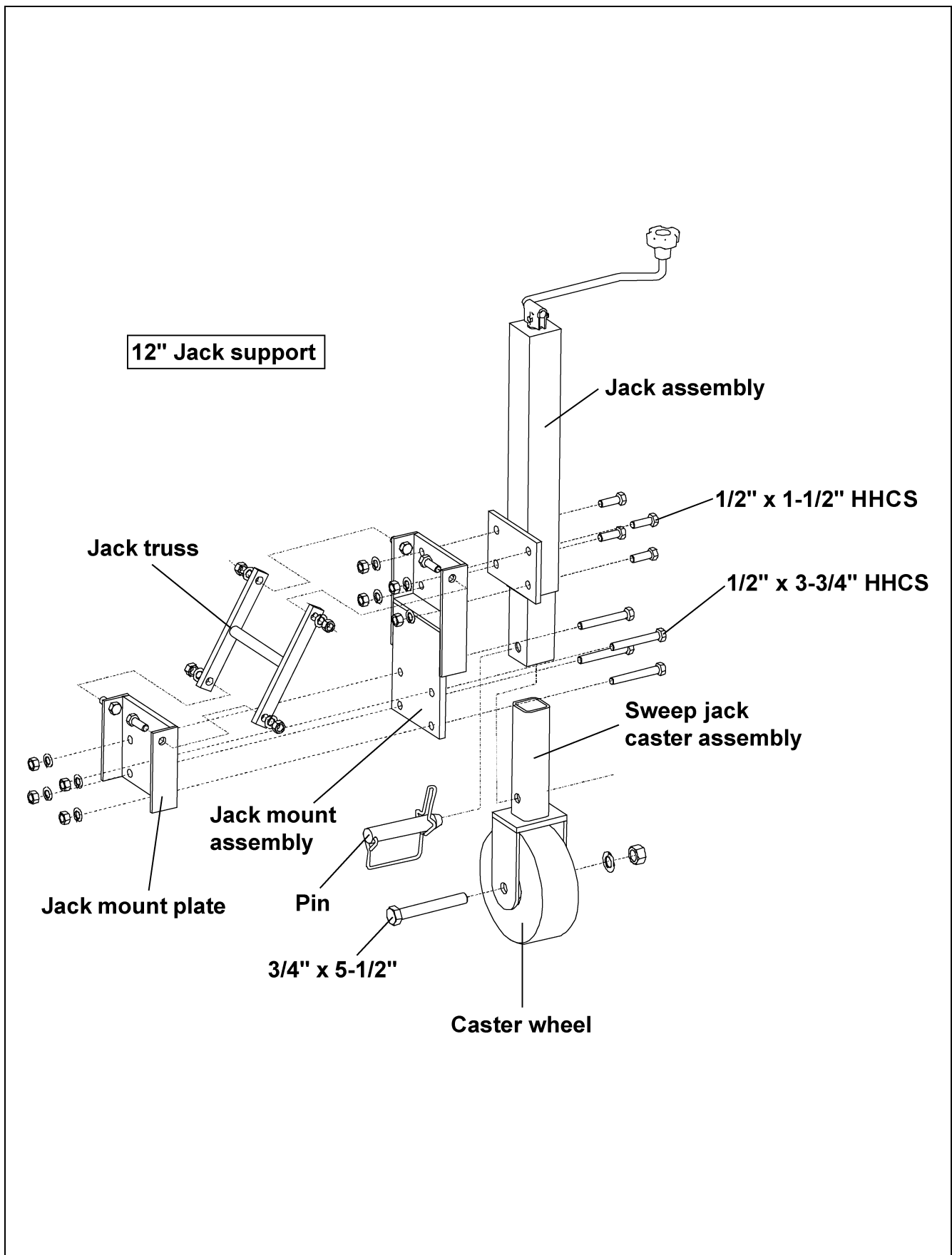

Figure 5AG

Center Pivot Installation

A. Center pivot with pivot kit

1. Use the pivot assembly supplied with the sweep pivot kit and cut it to fit, if needed.



The center pipe of the pivot assembly **MUST** be in the center of the bin. If it is not, the sweep could hit the bin wall.

2. Feed the multi-conductor cord through the hole in the back of the sweep head section leaving five feet (5') of cord outside the hole. (See Figure 5AH.)

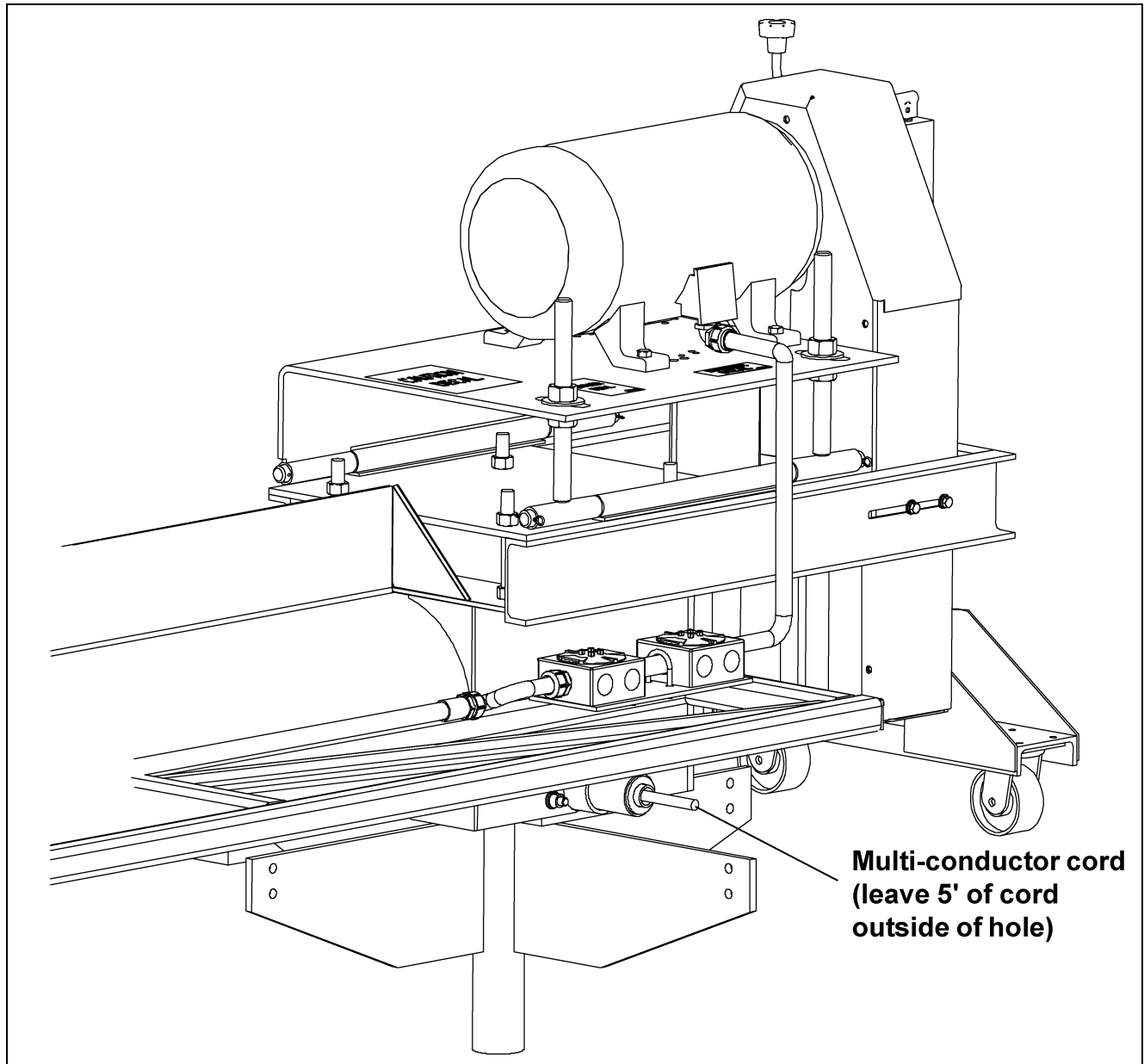

Figure 5AH

3. Feed the power cord through the pivot tube. (See Figure 5AI.)
4. Align the hole in the back shield with the pivot tube and push the sweep onto the pivot tube. (See Figure 5AI.)
5. Connect the pivot plate to the back shield using two (2) 1/2"-13 x 1-3/4" hex bolts, flat washers, lock washers and hex nuts. (See Figure 5AI.)
6. Fasten the pivot rod to the back shield and pivot plate using two (2) 1/2"-13 x 2" hex bolts, lock washers and hex nuts. (See Figure 5AI.)
7. Screw the 45° grease fitting into the pivot assembly pipe. (See Figure 5AI.)

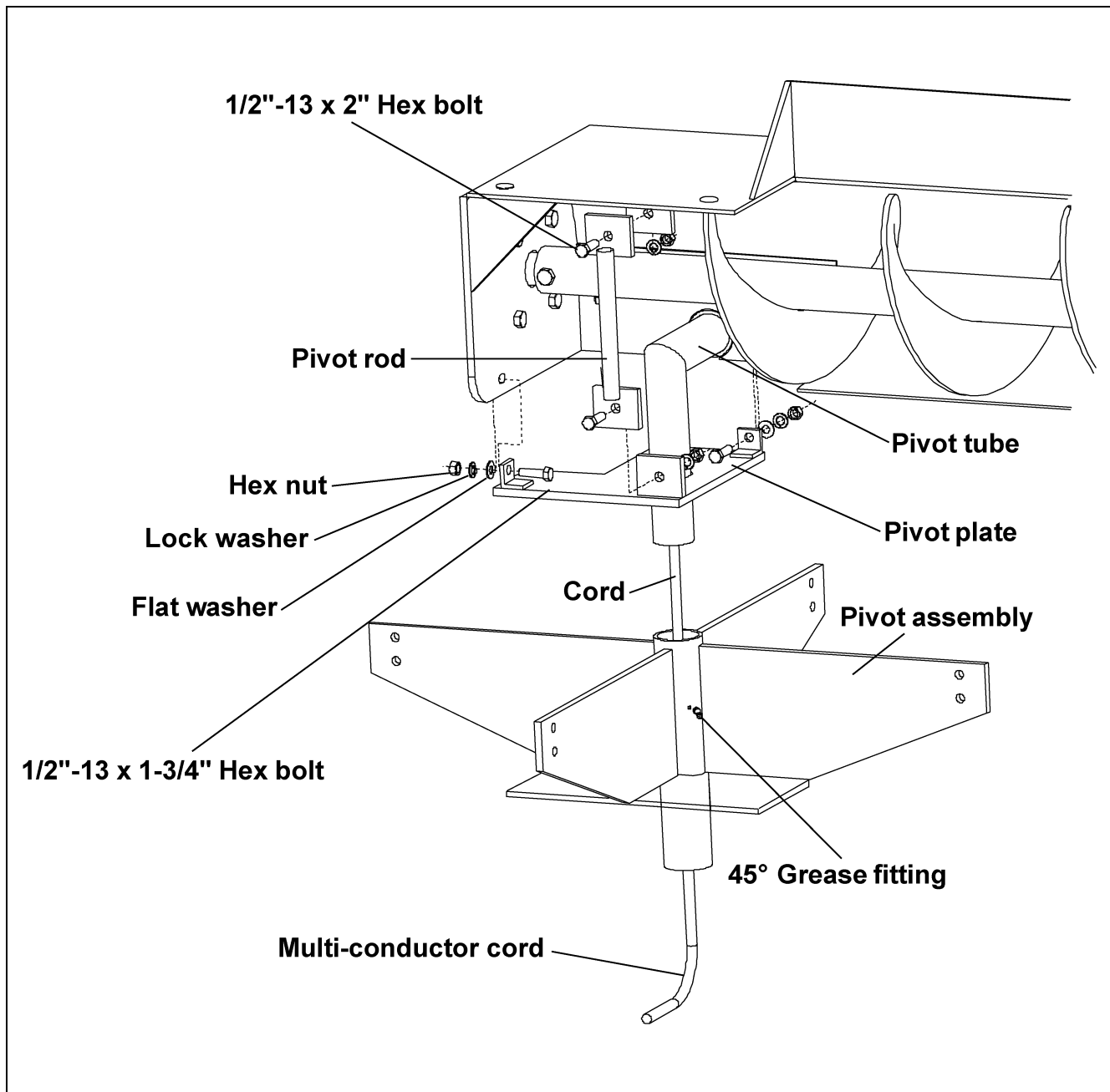

Figure 5AI

5. Assembly

8. Connect the 1" x 48" liquid-tight flex conduit to the pivot tube using one 1" conduit coupling and one 1" liquid-tight flex conduit coupling. *(See Figure 5AJ.)*
9. Connect the 1" x 48" liquid-tight flex conduit to one of the junction boxes using one 1" liquid-tight flex conduit coupling. Connect the leads as required. *(See Figure 5AJ.)*
10. The customer is to provide proper power cord protection between the pivot assembly and the sump transition. *(See Figure 5AJ.)*

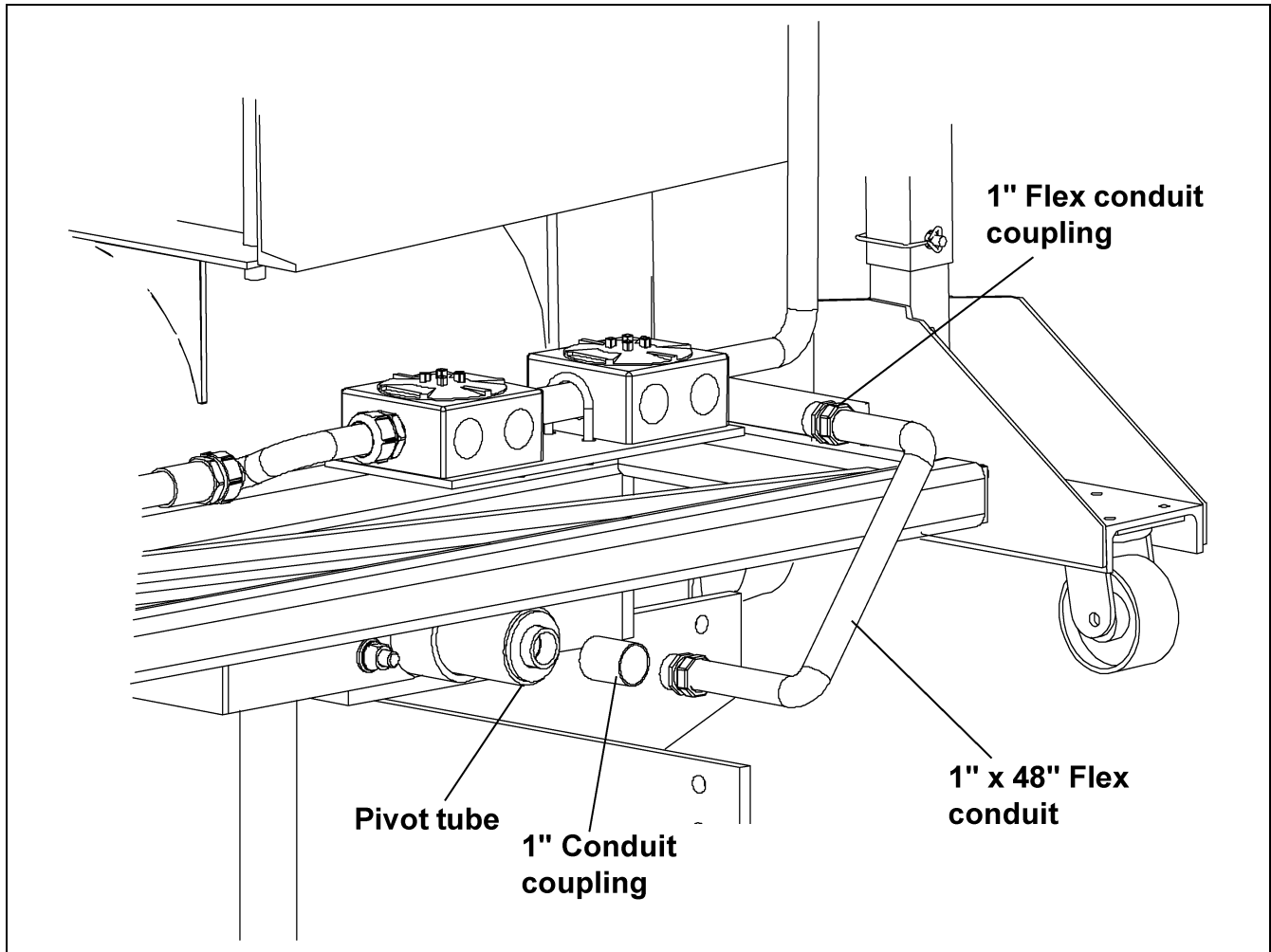

Figure 5AJ

11. The multi-conductor power cord can be connected with the 14 AWG/3 wire, 14 AWG/4 wire and 10 AWG/4 wire cords in an explosion proof junction box.
12. Hardwire foot switch to terminals 3 and 4 in control panel. *(See Schematic on Page 69.)*
13. Hardwire motor thermostat J-wires to terminals 1 and 2 in control panel. *(See Schematic on Page 69.)*
14. Hardwire motors to starters in control panel. *(See Schematic on Page 69.)*

Control Panel Setup

If the meter looks like this:

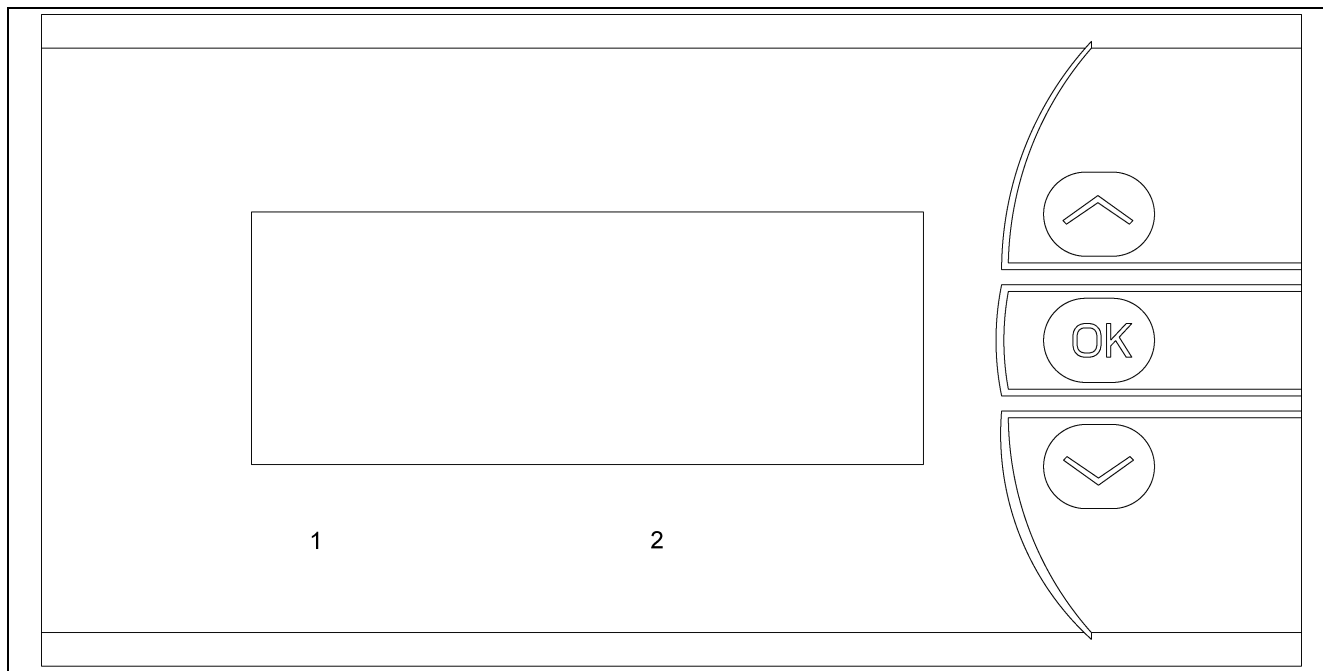

Figure 5AK

Follow these instructions:

The control panel is intended for hard wired connections for power in, auger drive motor wiring, tractor drive motor wiring and the thermal overload wiring for both the auger drive motor and the tractor drive motor.

If the system that this control panel is designed to have the cables for the auger drive motor and the tractor drive motor run inside the bin on the floor and exit through the bin door, a plug package is available to allow the panel to connect to the cords without hard wiring. This package is GC20117. This package is only standard in the center pin style sweep systems and not in the protected cord center sweep systems.

Control Panel Calibration

Observe the tractor drive motor nameplate and the auger drive motor nameplate.

Record the full load amp (FLA) value for the specific voltage on each motor.

Auger drive motor full load amps: ____

Tractor drive motor full load amps: ____

Switch the disconnect switch on the panel to OFF (not ON).

Unlock and open the control panel.

Adjust the FLA dial screw on the tractor drive motor contactor (M1) and the auger drive motor contactor (M2) so that the indicator arrowhead is set slightly higher than the full load amp value listed on the nameplates.

5. Assembly

Tractor drive motor contactor (M1) FLA adjustment dial: _____

Auger drive motor (M2) FLA adjustment dial value: _____

Close and lock the control panel.

Switch the disconnect switch on the panel to ON (not OFF).

Initial Display Setup

NOTE: *If no keys are activated for 2 minutes, the display returns to the default state without saving any configuration changes. At each value, after 5 seconds of inactivity, a description of the current state will scroll across the display.*

NOTE: *Pressing and hold OK will return to the previous menu or return to the default state without saving the changed values or parameters.*

Press OK on the display unit.

(IN) should be displayed on the unit.

Press \uparrow or \downarrow on the display unit until (CURR) is shown (not VOLT, POTM, or TEMP).

Press OK.

(RANG) should be displayed on the unit.

Press \uparrow or \downarrow on the display unit until 4-20 is shown (not 0-20).

Press OK.

(DEC.P) should be displayed on the unit.

Press \uparrow or \downarrow on the display unit until 11.11 is shown (not 1111, 111.1, 1.111 or .1111).

Press OK.

(DI.LO) should be displayed on the unit.

Press \uparrow or \downarrow on the display unit until 0 is shown.

Press OK.

(DI.HI) should be displayed on the unit.

The DI.HI value is 2x the value that the FLA dial on the auger drive motor (M2) that was set earlier.

2x FLA dial: _____

Press \uparrow or \downarrow on the display unit until the correct value is shown.

Press OK repeatedly until "----" is displayed. This indicates the programming described above has been saved.

Make sure no individual is inside the bin.

Make sure the sweep will not contact any obstruction and cause damage.

Have an employee observe the sweep from outside the bin, through the open door.

The person observing the sweep is meant to have control over the safety foot switch.

Have another employee operate the control panel.

Switch the Run Mode switch so that Manual is selected (not Auto).

Switch the Manual Mode switch to Idle (not reverse or forward).

Depress the pedal in the safety foot switch.

Press the Start button on the control panel.

NOTE: *If any damage is observed or there is abnormal operation of the sweep, shut it down immediately. There are three (3) ways to accomplish this. 1) Remove the pressure on the safety foot switch. 2) Press the Stop button on the control panel. 3) Press in on the Enable/Disable button so that it collapses appropriately. Switch the disconnect switch on the panel to OFF (not ON). Lock out the panel before entering the bin to service the sweep.*

Observe the no load amps (NLA) displayed on the meter on the front of the panel.

Auger drive motor no load amps: _____

The tractor motor operation (forward and stop) in automatic is dictated by the amp reading on the auger drive motor.

The tractor drive motor is meant to shut off (idle) when the auger drive motor reaches 90% of the nameplate FLA.

90% of full load amps: _____

The tractor motor is meant to reactivate (forward) when the auger drive motor reaches 110% of the no load amps (amperage observed when the auger flight turns freely in absence of grain).

110% of no load amps: _____

Final Display Setup

NOTE: *If no keys are activated for 2 minutes, the display returns to the default state without saving any configuration changes. At each value, after 5 seconds of inactivity, a description of the current state will scroll across the display.*

Press OK repeatedly until RELU is displayed on the unit.

Press \uparrow or \downarrow on the display unit until DISP is shown (not PERC).

Press OK.

REL1 should be displayed on the unit.

Press \uparrow or \downarrow on the display unit until SET is shown (not SKIP, or OFF).

Press OK.

SETP should be displayed on the unit.

Press \uparrow or \downarrow on the display unit the 90% of FLA value is shown.

Press OK.

ACT1 should be displayed on the unit.

Press \uparrow or \downarrow on the display unit until INCR is shown (not DECR).

Press OK.

5. Assembly

HYS1 should be displayed on the unit.

For this control panel hysteresis (HYS1) is measured as the different between 90% of full load amps and 110% of no load amps.

90% of full load amps: ____ minus 110% of no load amps: ____

Press \uparrow or \downarrow on the display unit until the correct value is shown.

Press OK.

ERR1 should be displayed on the unit.

Press \uparrow or \downarrow on the display unit until DEAC is shown (not HOLD, ACTI, or NONE).

Press OK.

ON.DE should be displayed on the unit.

Press \uparrow or \downarrow on the display unit until 0 is shown.

Press OK.

OF.DE should be displayed on the unit.

Press \uparrow or \downarrow on the display unit until 20 is shown.

Press OK.

REL2 should be displayed on the unit.

Press \uparrow or \downarrow on the display unit until OFF is shown (not SET or SKIP).

Press OK.

E.PAS should be displayed on the unit.

Press \uparrow or \downarrow on the display unit until NO is shown.

Press OK.

This function will allow the values that were entered to be locked.

NOTE: *Using a password will stop access to the menu and parameters. There are two (2) levels of password protection. Passwords between 0000 and 4999 allow access to the fast set point adjustment and relay test. (Using this password stops access to all other parts of the menu.) Passwords between 5000 and 9999 stop access to all parts of the menu, fast set point adjustment and relay test. (Current set point is still shown.) By using the master password 2008, all configuration menus are available.*

If you select NO, press OK.

If you select YES, N.PAS will be displayed. Press \uparrow or \downarrow on the display unit until your password is shown. Press OK. Document this password.

The password will be necessary if there needs to be changes to many of the configuration values.

If the meter looks like this:

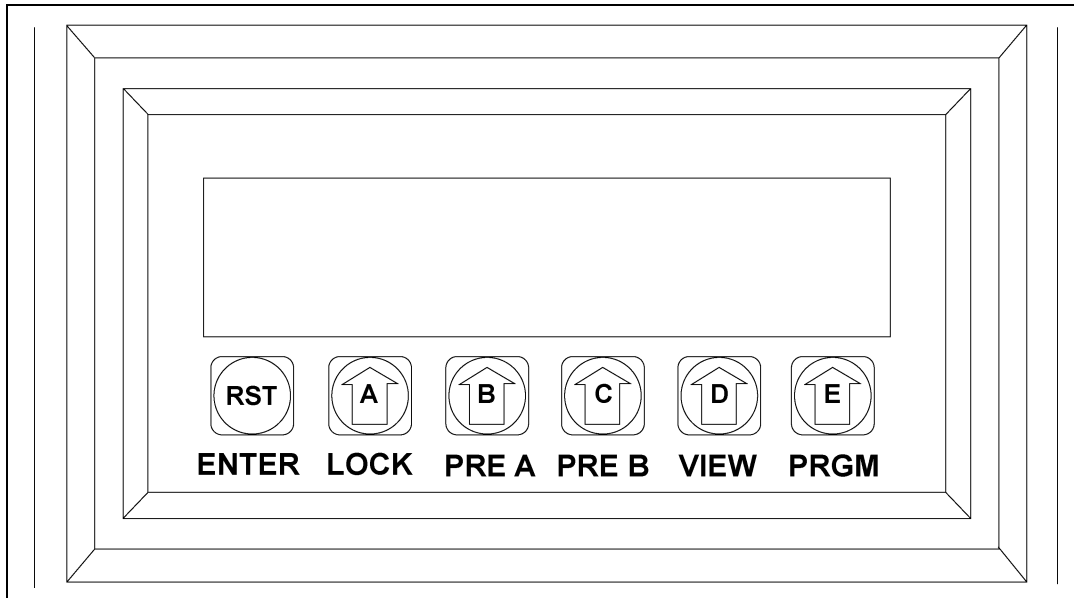

Figure 5AL

Follow these instructions:

NOTE: *In order to fine tune the control panel, the bin must have grain in it.*

The Series II Sweep is supplied with adjustable overloads that are not set at the factory. These should be set slightly higher than the Full Load Amp (FLA) value listed on the motor nameplates.

A. Find the desired “High” Amp and “Low” Amp set points.

1. **High Amp Set Point:** The Amp load the auger draws when the auger flighting is 90% loaded. This will turn OFF the tractor drive motor. Initially, set the value to 90% of the Full Load Amps (FLA) listed on the motor nameplate.
2. **Low Amp Set Point:** The Amp load the auger motor draws when the auger flighting is 10% loaded. This will turn ON the drive motor. Initially, set this value to 10% over the Amp draw of the sweep running empty.



NEVER program the “High Amp Set Point” greater than the full load running Amps of the auger motor.

B. Programming the Amp Meter.

Calibration

1. Setting Input

a. Press "PRGM" to "inPut".



b. Press "ENTER".

c. Press "PRGM" to "i4-20".



d. Press "ENTER" to RUN MODE.



2. Setting Setup

a. Press "PRGM" to "SEtUP".



b. Press "ENTER" to "rdEC".

Use arrow buttons to change the decimal placement. Show .0 Amps.



c. Press "ENTER" to "SETLO".

d. Press "ENTER"

Value = 0.0



e. Press "ENTER" to "SEtHi".

f. Press "Enter"

Value = 50.0



Use arrow buttons to change value.

g. Press "ENTER" to "LoCut".

Press "ENTER"

This value = 0



h. Press "ENTER" to RUN MODE.



Operation

1. Setting Presets

- a. Press "Pre A".
- b. Press "PRGM"
This value = "High Amp Set Point".
Use arrow buttons to change value.
- c. Press "ENTER".

2. Setting Relays

- a. Press "PRGM" to "rELAYS".
- b. Press "ENTER" to "HYS A".
- c. Press "PRGM"
This value = "High Amp Set Point"- "Low Amp Set Point"
Use arrow buttons to change value.

- d. Press "ENTER" to RUN MODE.



EXAMPLE: Full Load Running Amps = 21 Amps

High Amp Set Point = 20 Amps

Low Amp Set Point = 12 Amps

Then "HYS A" = 8 Amps

And "Pre A" = 20 Amps

NOTE: *This is the difference between the High Amp Set Point and the Low Amp Set Point. [20 Amps-12 Amps = 8 Amps].* Low Amp Set Point is only used to calculate this value.

C. Locking the Amp Meter

1. Locking the Amp meter is not required but prevents the meter from being tampered with once it is programmed.
2. In RUN MODE, press "LOCK" three (3) times within five (5) seconds.
This value = A number that is easily remembered.
Use arrow buttons to change value.
 - a. Press "ENTER".

D. Unlocking the Amp Meter

1. In RUN MODE, press "LOCK" three (3) times within five (5) seconds.
 - a. Enter the "LoC" value.
Use arrow buttons to change value.
 - b. Press "ENTER".

NOTE: *It is recommended to write down the "LoC" value and keep it in a safe place in case it is forgotten.*

Perform Pre-start Checks



To ensure that the drive is not unexpectedly started, turn OFF and lock out the power source before proceeding. Failure to observe these precautions could result in bodily injury.



*Failure to perform any or all of these pre-start checks may cause damage to the equipment and/or cause **SERIOUS INJURY** or **DEATH** to those in the work area.*

Failure to perform any or all of these pre-start checks may also be a misuse of the equipment. Any misuse of the equipment may void the warranty.



***ALWAYS** keep **ALL** guards and shields in place, until all the power is disconnected and locked out.*

- A. Make sure ALL shields are in place.
- B. Inspect the drive unit for any problems or potential problems.
- C. Be aware of any emergency shut down procedures. Two (2) people must always be in position to monitor the operation of the equipment from outside the bin.
- D. Before starting the auger for the first time, make sure that all parts are assembled correctly according to the instructions in this manual.



Be sure to remove the grain from the drive chain and sprockets. If this is not done, damage can occur to the drive system.



*Make certain **ONLY** trained operators are in the work area before operating or moving the machine. Two (2) people must always be in position to monitor the operation of the equipment from outside the bin.*

Start the Auger



DO NOT start or stop the auger while it is under load.

- A. Step on the foot switch and press the “Start” button.
- B. Run the auger through a “break-in” period if it is being used for the first time or for the first time of the season.
- C. “Polish” the flighting by running the auger at partial capacity until it is smooth, before attempting full capacity.



Failures may occur if the auger is run full before it has been “polished” during the “break-in” period.



NEVER operate the auger empty. Operating augers empty for any length of time will cause excessive wear. NEVER operate the auger at speeds higher than recommended.



Be aware of any unusual vibration or noises during the initial start-up and “break-in” period. If anything unusual is detected, immediately shut down the auger and disconnect and lock out the power supply before servicing.

Operating the Sweep Auger

CAUTION

Gear reducer is shipped without oil. Add the proper amount of the recommended lubricant before operating. Failure to observe these precautions could result in damage to, or destruction of, the equipment.



Keep out of the bin while the bin sweep auger is in operation. The rapidly moving sweep auger can cause **SERIOUS INJURY** or **DEATH**.

NOTE: *The auger capacity can fluctuate greatly under varying conditions. Moisture content, different commodities, amount of foreign matter and speeds all play a part in the performance of the auger. Twenty-five percent (25%) moisture may cut capacity by as much as 40% under some conditions.*

- A. Make certain there are at least two (2) people in the work area to monitor operations at all times.
- B. Start the bin unloading equipment before starting the bin sweep auger.



Be alert for any unusual vibrations, noises and the loosening of any fasteners. If anything unusual is detected, immediately shut down the auger, disconnect and lock out the power source before servicing.

- C. Shut down the auger as soon as the bin is empty.
- D. Consideration should be given to the proper size auger for any intermittent type operations. When augers are stopped and restarted under full load, it may result in damage to the auger. Using a larger diameter auger and reducing its load level will be far better than subjecting a smaller diameter auger to big loads. If an auger is kept from absolute filling, it will make start-up easier and will convey more efficiently.



NEVER enter the bin while the bin sweep is in operation.

NEVER attempt to control the operation of the bin sweep by depressing the operating controls with shovels, brooms or any other objects.

DO NOT attempt to restrain movement of the bin sweep with ropes, bars or other devices.

NEVER allow an operator to attempt to manually restrain the bin sweep.

Operating the Sweep Auger Control Panel

A. The sweep operates in two (2) different “modes”.

1. Automatic (The auger motor runs and the drive motor runs using the Amp Meter in the control panel.)

Step on the foot switch and press the “Start” button. The auger motor will turn ON and the drive motor will turn ON only if the Amp Meter reaches the “Low” set point.

2. Manual (Overrides the Amp Meter and allows the operator to manually move the sweep.)

- a. Idle (Allows the auger motor to run, but does not move the sweep forward or reverse.)
- b. Forward (Auger motor will run and moves the sweep towards the grain.)
- c. Reverse (Stops the auger motor and moves the sweep away from the grain.)

Step on the foot switch and press the “Start” button. The auger motor will turn, but the sweep will not move. Turn the “Manual” switch to “Forward” and the sweep will move forward towards the grain. Turn the “Manual” switch to “Reverse” and the auger motor will shut off and move the sweep backwards away from the grain.

The “Start” button MUST be pressed to start the auger motor again.

NOTE: *The foot switch MUST be depressed and the thermal protection cord wired in before the sweep will operate.*

8. Shut Down

Normal Shut Down

- A. Before shutting down the unit, be sure the sumps and unload conveyor are empty.
- B. Press the “Stop” button on the control panel.

Emergency Shut Down

- A. Know how to shut down the auger in case of an emergency.
- B. Step off the foot switch and press the “Stop” button.
- C. Disconnect and lock out the power source.

CAUTION	<i>NEVER start the equipment under load. Doing so may cause damage. This type of damage is considered a misuse of the equipment. Any misuse of the equipment may void the warranty.</i>
----------------	--

Storage Preparation

- A. Be sure the sumps and unload conveyor are empty.
- B. Close the sump control gates.
- C. Park the sweep behind the intermediate sumps, so that the sumps are on the auger side of the sweep.
- D. Shut down the auger.
- E. Make sure all fasteners are tight.
- F. After allowing the motors to cool down, cover the motors with the tarps supplied with the sweep.
- G. Place blocks under the frame of the sweep to help support the sweep during storage.

Maintain the Auger



ALWAYS shut down and disconnect the power supply before adjusting, servicing or cleaning the equipment.

- A. Use caution when repairing or replacing equipment parts.
- B. Make sure ALL decals are legible and securely attached to the auger. If necessary, replace them **FREE OF CHARGE** by contacting GSI at:

GSI
1004 E. Illinois St.
Assumption, IL. 62510
Phone: 1-217-226-4421

- C. Ensure that ALL electric motors, etc., are operating at the proper speed.
- D. Make sure ALL electrical wiring is not damaged and that it meets proper wiring codes.
- E. Make sure ALL components are in good working condition before use.

CAUTION

ALL SPEED REDUCERS ARE SHIPPED DRY. OIL MUST BE ADDED PRIOR TO OPERATION. Do not operate the unit without making sure it contains the correct amount of oil. Do not overfill or underfill with oil or injury to personnel, unit or other equipment may result.

CAUTION

Do not mix non-synthetic and synthetic oil in the unit.

Lubrication

A. Lubrication – Electric Motors

Electric motors supplied for use on Series II Sweeps are properly lubricated at the time of manufacture. It is not necessary to lubricate them at the time of installation unless the motor has been in storage for one year or longer. Some motors may be factory lubricated and sealed for the life of the bearings. Overgreasing the bearings can cause premature failure of the motor. The amount of grease added must be carefully controlled.

B. Procedure for Lubrication of Electric Motors

1. Stop motor. Disconnect and lock out of service.
2. Follow all safe bin entry procedures and wear all required personal protective equipment.
3. Remove contaminants from grease inlet area.
4. Remove filler and drain plugs.
5. Check filler and drain holes for blockage and clean as necessary.
6. Add proper type and amount of grease. *See Chart below and on Page 65* for amount of lubricant. Too much grease or injecting grease too quickly can cause premature bearing failure. Use approximately one minute to slowly inject the recommended amount of grease.
7. Wipe off excess grease and replace filler and drain plugs. Do not run motor without the grease and drain plugs installed.

NOTE: *It is very important to keep the grease clean. Mixing dissimilar grease is not recommended.*

C. Type of Lubrication

A polyurea mineral oil NGLI grade 2 type grease is to be used for lubrication of the electric motors. Grease meeting this specification include:

- | | |
|-----------------|-------------|
| 1. Chevron | SRI #2 |
| 2. Exxon-Mobile | Polyrex EM |
| 3. Texaco | Polystar RB |

D. Frequency of Lubrication

Motors should be relubricated after storage of one year or more or at the beginning of each season. The following *Chart* gives the amount of grease to be added.

**Lubrication - Electric Motors
Quantity of Grease per Frame Size**

For Baldor Brand Electric Motors		
NEMA Frame Size	Volume	
	Cu. in.	Fluid oz
56C		
143TC	0.25	0.14
182TC	0.5	0.28
184TC	0.5	0.28
213T	0.75	0.42
215T	0.75	0.42
254T	1	0.55
256T	1	0.55
284T	1.25	0.69
286T	1.25	0.69
324T	1.5	0.83

For Marathon Brand Electric Motors				
NEMA Frame Size	Volume			
	Cu. in.	Ounce	Gram	Teaspoon
56C				
143TC	0.6	0.3	8.4	2
182TC	0.6	0.3	8.4	2
184TC	0.6	0.3	8.4	2
213T	0.6	0.3	8.4	2
215T	0.6	0.3	8.4	2
254T	1.2	0.61	17.4	3.9
256T	1.2	0.61	17.4	3.9
284T	1.2	0.61	17.4	3.9
286T	1.2	0.61	17.4	3.9
324T	1.5	0.81	23.1	5.2

E. Lubrication – Reducers (Gearboxes)

Reducers supplied for use on Series II Sweeps are shipped without lubricant (dry). The proper lubricant must be added at the time of installation. Over lubrication may cause premature failure of the reducer. The amount of lubricant must be carefully controlled.

F. Procedure for Initial Filling of Reducers

1. Disconnect and lock motor out of service. Do not run gearbox without lubricant.
2. Follow all safe bin entry procedures and wear all required personal protective equipment.
3. Remove contaminants from inlet area.
4. Remove filler and oil level fill plugs.
5. Check filler holes for blockage and clean as necessary.
6. Clean the magnetic drain plug if one was supplied.
7. Add proper type of lubricant to fill level or until oil runs out of oil level fill hole.
See the Lubrication Chart on Page 66 for amounts and types of lubricant.
8. Wipe off excess lubricant and replace filler and oil level fill plugs.

NOTE: *It is very important to keep the lubricant clean. Mixing dissimilar lubricants is not recommended.*

G. Procedure for Changing of Lubricant

1. Stop motor. Disconnect and lock out of service.
2. Follow all safe bin entry procedures and wear all required personal protective equipment.
3. Remove contaminants from inlet and drain area.
4. Remove filler, oil level fill and drain plugs. Drain old lubricant from reducer.
5. Flush reducer with a nonflammable solvent such as lubriplate pure flush or whitmore's flushing oil.
6. Clean the magnetic drain plug if installed.
7. Carefully replace drain plug.
8. Add proper type of lubricant to fill level or until oil runs out of oil level fill hole.
See the Lubrication Chart on Page 66 for amounts and types of lubricant.
9. Wipe off excess lubricant and replace filler and oil level fill plugs.

NOTE: *It is very important to keep the lubricant clean. Mixing dissimilar lubricants is not recommended.*

9. Maintenance

H. Frequency of Lubrication

Lubricant should be changed after storage of one year or more or at the beginning of each season.

I. Type of Lubrication

The type and quantity of lubrication required for each type and size of reducer is listed in [the following Chart](#).

Lubrication - Gearboxes Quantity and Type of Lubricant per Box Size

Hub City (Tractors Driver) Reducer	
Box Series	Volume
	Pints Worm Top
520	10.6
Lubrication Specification	
Mobile	SHC634-Synthetic
	Or Equal

NOTE: Lubricant capacities are approximate, fill until lubricant starts coming out oil level plug hole.

EPT Browning (Screw Drive)		
Box Size	Volume (Quarts)	
107-09	2 Approximately	
115-09	2.56 Approximately	
203-09	4 Approximately	
207-09	6.3 Approximately	
215-09	9 Approximately	
Lubrication Specification		
Mineral Oil	Temp 15°F-60°F	Temp 50°F-125°F
	AGMA 4	AGMA 5
Mobile Oil Company	DTE Oil Extra Heavy	DTE-Oil BB
Synthetic Oil	Temp 0°F-90°F	Temp 15°F-125°F
	AGMA 4	AGMA 5
Mobile Oil Company	Mobile SHC 629	Mobile SHC 630

J. Lubrication – Bearings, Casters and Jacks

The flange bearings, pillow block bearings and casters supplied for use on Series II Sweeps are shipped from the factory lubricated. From time to time a small amount of the proper lubricant must be added. Over lubrication may cause premature failure of the components.

K. Procedure for Lubricating Flange and Pillow Block Bearings

1. Disconnect and lock motors out of service.
2. Follow all safe bin entry procedures and wear all required personal protective equipment.
3. Remove contaminants from the grease zerk and surrounding area.
4. Add proper type of lubricant. See the lubrication chart on [Page 68](#) for types of lubricant.
5. Wipe off excess lubricant.

NOTE: *It is very important to keep the lubricant clean.*

L. Procedure for Lubricating Casters

1. Disconnect and lock motors out of service.
2. Follow all safe bin entry procedures and wear all required personal protective equipment.
3. Remove contaminants from the grease zerk and surrounding area.
4. Add proper type of lubricant. See the lubrication chart on [Page 68](#) for types of lubricant.
5. Wipe off excess lubricant.

NOTE: *It is very important to keep the lubricant clean.*

M. Procedure for Lubricating Jacks

1. Disconnect and lock motors out of service.
2. Follow all safe bin entry procedures and wear all required personal protective equipment.
3. Lubricate the gears using the grease zerk at the top of the jack. Rotate the jack handle to distribute the grease.
4. Lightly grease the inner tube of the jack using the same type of grease.
5. Apply a light weight oil to the handle unit at both sides of the tube.
6. Apply a light weight oil to the small hole at the upper end of the jack to lubricate the nut and screw assembly.

N. Frequency of Lubrication

The tractor drive pillow block bearings and the end flange bearing, along with the casters, should be lubricated after each use of the Series II Sweep. If possible, lubricate all the components at the beginning of each season or after long term storage.

9. Maintenance

O. Type of Lubrication

The type of lubrication required, for each component, is listed in the following [Chart](#).

Lubrication - Bearings, Casters and Misc. Equipment Type of Lubricant		
Equipment	Lubrication Specification	
Tractor Drive Pillow Blocks	Shell Oil Company	Alvania #2 (or equivalent)
End Flange Bearing	Shell Oil Company	Alvania #2 (or equivalent)
Nylon Flight Bearings	None Required	None Required
Head End Casters	Shell Oil Company	Alvania #2 (or equivalent)
Jack Casters	Shell Oil Company	Alvania #2 (or equivalent)
Jacks	Shell Oil Company	Alvania #2 (or equivalent)

CAUTION

Too much oil will cause overheating and too little will result in gear failure. Check oil level regularly.

CAUTION

Extreme pressure (EP) lubricants are not recommended for average operating conditions. Failure to observe these precautions could result in damage to or destruction of the equipment.

CAUTION

Under Extreme operating conditions, such as rapid rise and fall of temperatures, dust, dirt, chemical particles, chemical fumes or oil sump temperature above 200°F, the oil should be changed every 1 to 3 months, depending on severity of conditions.



CAUTION

If the unit is used in the food or drug industry (including animal food) consult the petroleum supplier for recommendations on lubricants which meet the specifications of the FDA, USDA and/or other authoritative bodies having jurisdiction. Standard lubricants are not suitable for these applications or these industries.



WARNING

Oil, housings and other components can reach high temperatures during operation and can cause severe burns. Use extreme care when removing lubrication plugs and vents while servicing the unit.

NOTE: *The pour point of the lubricant selected should be at least 10°F lower than the expected minimum ambient starting temperature. Extreme pressure (EP) lubricants are not recommended for average operating conditions.*

Control Panel Schematic (460/3/60) Post-May 2010

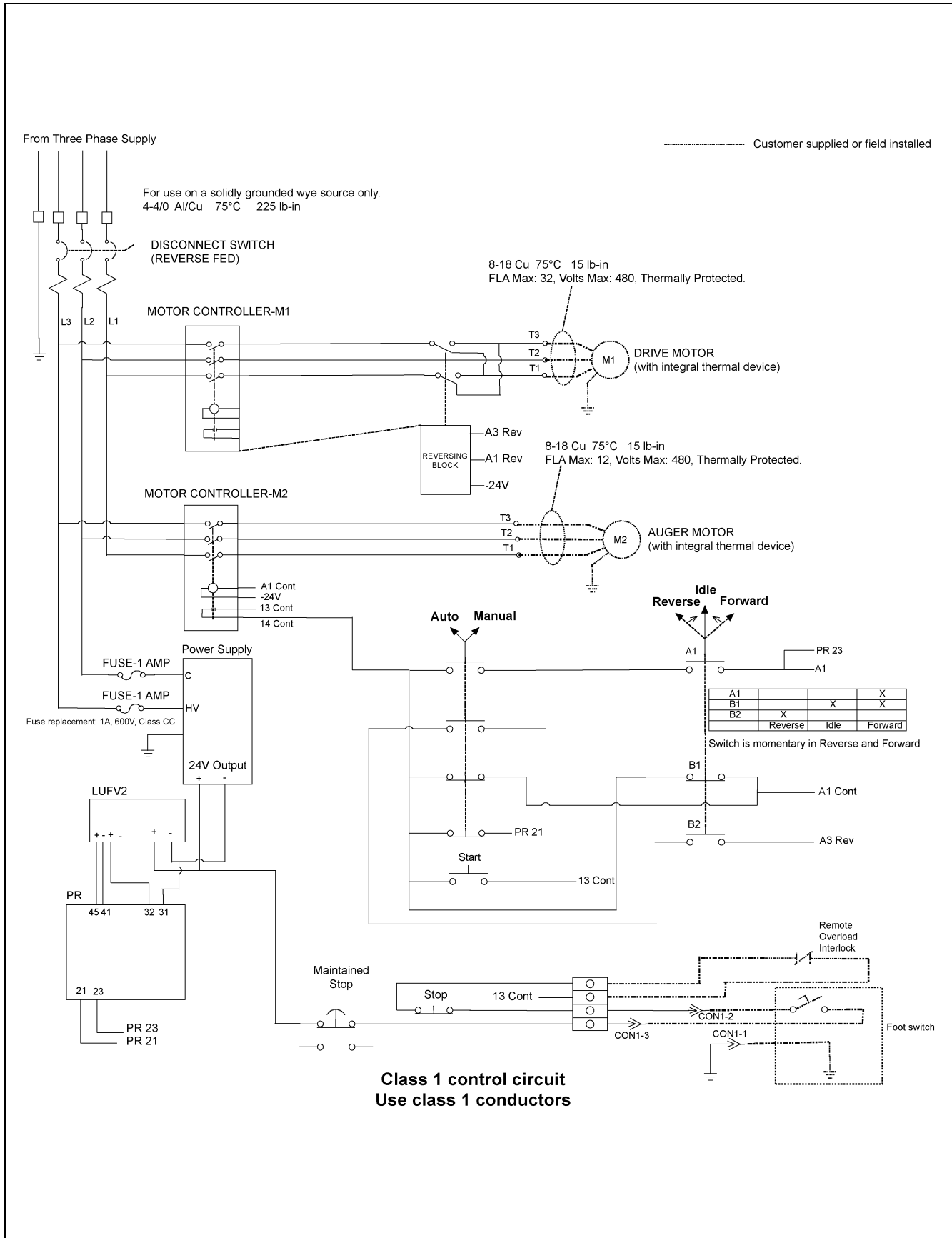

Control Panel Schematic (460/3/60) Pre-June 2010

NOTE: All wires are to be 18 AWG unless otherwise noted.

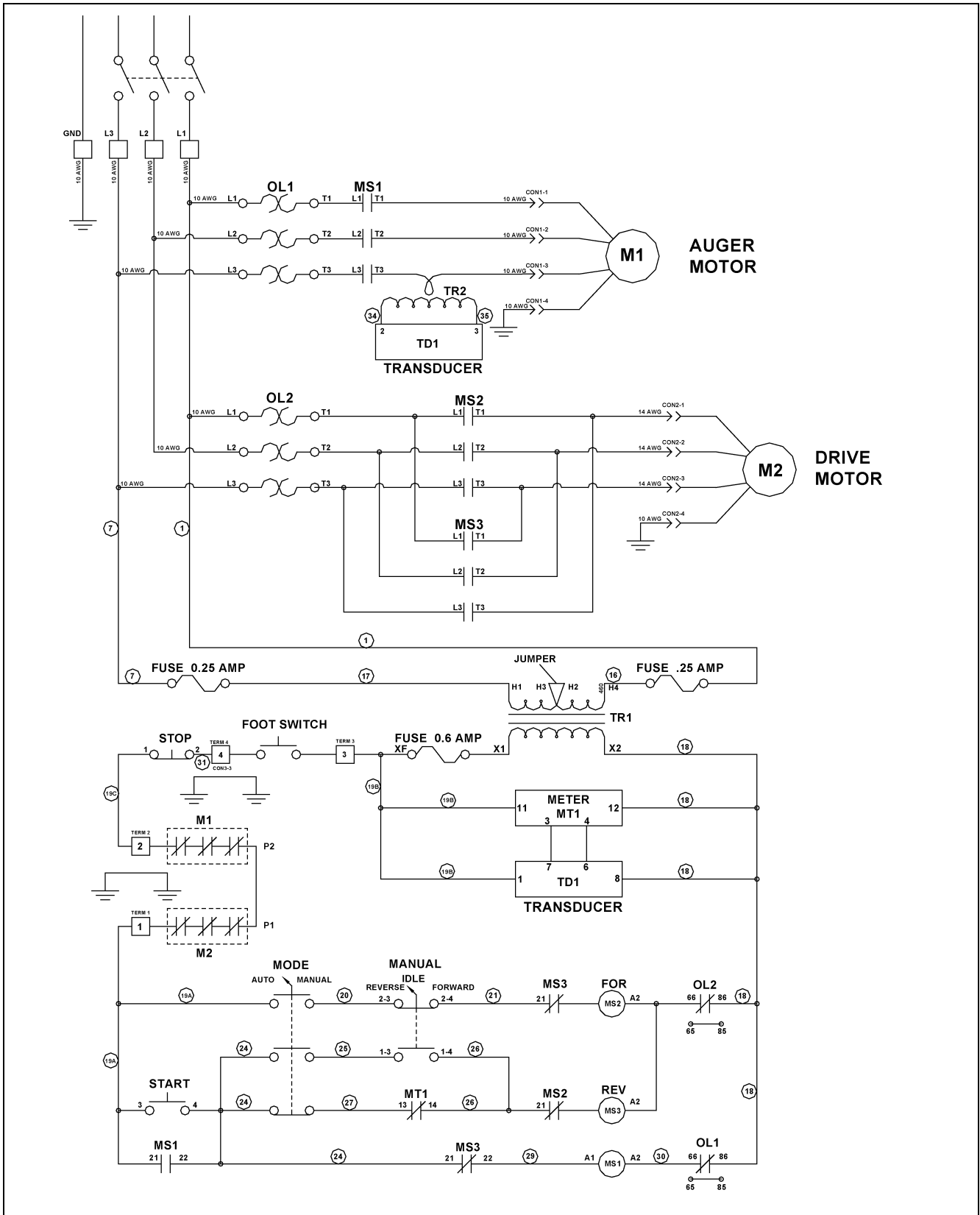

Problem	Possible Cause	Solution
1. Sweep does not run.	1. Foot switch may not be actuated.	1. Make sure the foot switch is depressed and the switch is operating properly.
	2. Overloads may be tripped.	2. Reset the overloads.
	3. Adjustable overloads not set correctly.	3. Set overload to 10% over the value listed on motor nameplate for full load amps.
2. Low capacity.	1. The auger may not be fully loaded.	1. Make sure the grain is flowing into the auger, making it fully loaded.
	2. The auger is moving too slowly.	2. Check the auger speed. Low capacity results from speeds slower than recommended.
3. Sweep does not move around the bin.	1. The control panel may not be in "automatic mode".	1. Turn the switch to "automatic mode".
	2. The amp meter is not properly adjusted.	2. Set the amp meter so the running amps of the auger motor turns ON the drive motor.
	3. The drive chain may be broken.	3. Repair the drive chain.
4. The sweep is vibrating.	1. The auger may have foreign materials in it.	1. Remove the foreign material.
	2. The hanger bearings may be worn.	2. Replace the hanger bearings.
	3. The flight connections may be loose.	3. Tighten all of the flight connecting bolts.
	4. The flighting may be worn.	4. Replace all the flighting sections that are worn.

FAQs

Who do I contact for parts or service?

Contact your dealer. If your unit was purchased direct from GSI, contact your inside sales person.

What is/where do I find the model number of my sweep?

The model number of your sweep can be found on your quote or invoice. A space is provided at the front of your manual to record this number.

The model number code is as follows:

Style	Diameter	Size and Capacity	Voltage	Option 1	Option 2	Option 3
H	36'	-12 - 5	F			
K	***	-12 - 6	G	P	T	1
	135'	-12 - 7	J	B		
		-16 - 8	K	Q		
		-16 - 9				
		-16 - 10				

Standard H Welded Truss (36'-135')	GSI Standard Bin Diameter	-12 - 5 12" Flight and 5000 BPH	F 380/3/50	(Standard) Pin Center Sump Design, for Cables on the Floor (Not Through Sump)	(Standard - 36'- 120') V-Belt Flight PT, (Standard- 135') HT200 Flight PT	(Standard) GSI Flight PT HP
		-12 - 6 12" Flight and 6000 BPH	G 575/3/60			
		-12 - 7 12" Flight and 7000 BPH	J 415/3/60	Pivot Plate Center Sump Design, for P Center Protected Cables or Center Slip Ring		
Knockdown Truss (Not Available above 120')	GSI Standard Bin Diameter	-16 - 8 16" Flight and 8000 BPH	K 460/3/60	Control Panel Not Included Q Same as P + B	T (36'-120') HT200 Flight PT	1 Increased Flight PT HP
		-16 - 9 16" Flight and 9000 BPH				
		-16 - 10 16" Flight and 10000 BPH				

Do I want to buy a pivot or a standard sweep? What is the difference?

The following [Figure 11A](#) is of a 12" pivot sweep head end weldment and a 12" standard sweep head end weldment. There are very few differences between the two. The standard head weldment has the female pivot tube welded to the drive end of the unit. Two (2) plate braces and one pipe brace support this tube. The pivot head weldment has a lug welded to the underside of the motor mount plate. This lug is for attachment of the sweep pivot rod assembly. There is a large hole in the rear plate for the center support tube assembly to pass through. Next to the large hole is a slot that the center support mounts to.

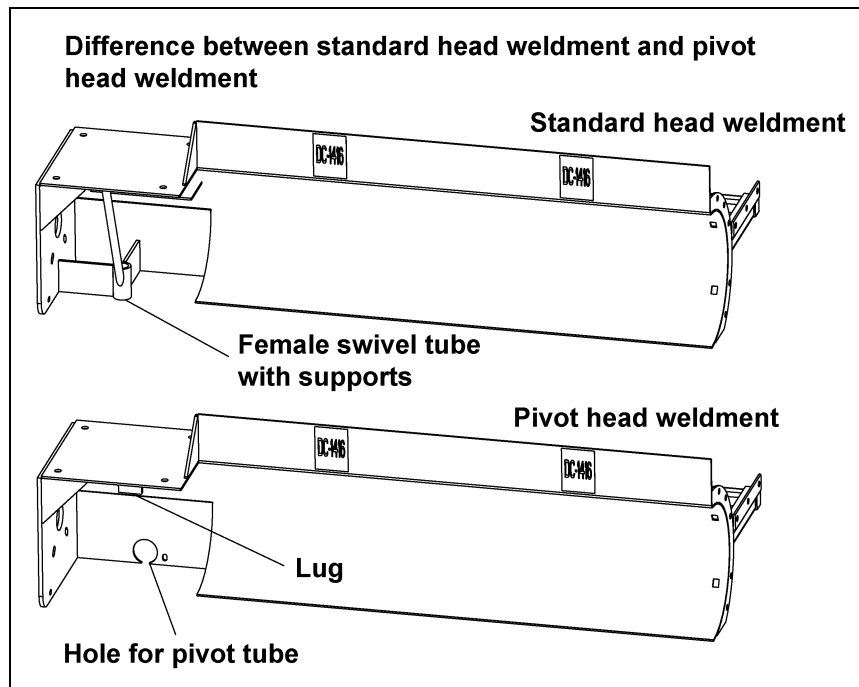

Figure 11A

How complete is the Series II Sweep?

With the exception of a few electrical connectors, all components required to assemble your sweep are included.

How level does my floor need to be for the sweep to operate properly?

The top edge of the sump hopper and the top edge of the "X" brace support must be level with the floor. The floor must be level within 3/4" plus or minus, preferably less. Any high or low points must be gradually sloped. The change in elevation should be no more than 3/4" over 60".

Where should the center pivot pin be located?

The center pin or pivot pipe **must** be in the center of the bin. If it is not, the sweep could hit the bin wall. There should be between 2" and 14" of clearance between the end of the sweep and the closest obstruction (bin wall, stiffeners, etc.).

How round must my bin be for the sweep to operate properly?

Diameter tolerances are limited by foundation limits and sweep operation as well as structural issues. For 72' diameter and larger bins, the overall tolerance would be plus or minus 1-1/4" on the radius, plus or minus 1" on 42'-66' diameter bins and plus or minus 3/4" on 30'-39' bins.

11. Troubleshooting

How large of an opening do I need for a standard flow (15000 BPH) center sump?

If installing a GSI supplied sump shell with collector ring, the opening must be 42-1/2" x 42-1/2" x 30" deep for the 12" sweep.

The sump hopper supplied by GSI was designed with sufficient clearance around the collector ring housing to allow grain to gravity flow through the hopper and be carried away by the material handling equipment below it. 42-3/4" is the maximum opening size to allow rolling clearance for the casters assembled to the head end jack. If the sump is made smaller, grain flow may decrease to an unacceptable level.

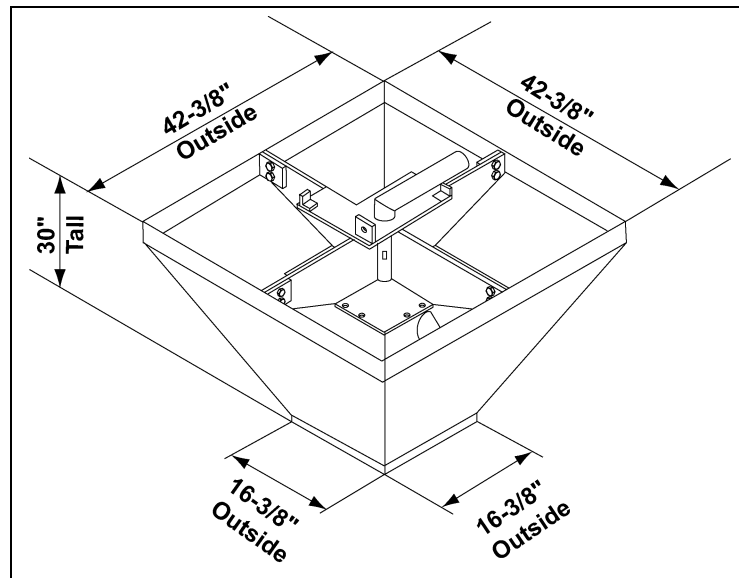

Figure 11B

The open area of this sump is misleading. The collector ring housing sticks down into the sump, blocking off a portion of the flow. Also, the sweep covers about one quarter of the opening at the top. We use 75% of the theoretical flow around the housing for the actual flow.

What intermediate sump spacing do I need? Why?

It is required to install the intermediate sumps on a maximum of 10' centers where the sweep will be parked during storage. The first intermediate sump should be placed a maximum of 10' on center from the center sump and the end sump should be no farther than 4' from the bin wall. The extra sumps will help clean out the grain in front of the sweep, reducing the start-up load. Doing this will save labor dollars and hours of work to dig out the sweep and will help the sweep during start-up. The sweep is not designed to start-up when submerged in material. The sweep should be parked behind the intermediate sumps with the sumps on the auger side of the sweep.

Do I need to clean out around the end of the sweep prior to starting it up?

Enough material must be removed from around the tractor drive and the screw drive units to allow access to the motor/drive covers. Both the chain drive and the belt drive must be free of grain before and during operation.

Where do I park the sweep before I fill the bin with grain?

There is a section in the manual called "[Storage Preparation on Page 62](#)". The section says to "Park the sweep behind the intermediate sumps, so that the sumps are on the auger side of the sweep". The sweep should not completely cover the inside sump hole (the one closest to the center sump). You will have to clean out around the tractor drive and the jack wheels before operation.

Where do I find the track dimensions?

The wheel path dimensions are listed at the front of the Owner's manual. Your dealer also has a copy of the path dimensions in his price book. The head jack wheels are not listed on the chart. These are always 34" from the center of the bin. The area around the center sump must be kept clear for the head jack wheels to roll.

What do I need to hook electrical power to the Series II Sweep?

The Series II Sweep is designed to operate using **460 volt 3 phase 60 cycle power**. The voltage must be within **plus or minus 4%** for proper operation. Voltages outside of this range may cause excessive power draw or other operating problems. Please contact the factory for applications outside of these parameters.

The power must be locked out before servicing the equipment, entering the bin, or resetting the motor overloads.

The wiring to the GSI supplied control box is the owner's responsibility and is not included with the sweep.

Electrical controls and wiring should be installed by a qualified electrician. The conductor cables should comply with the National Electrical Code and any state or local codes which may apply.

How does the Series II Sweep operate?

The Series II Sweep is designed with a small controller in the control panel door to monitor the load on the screw motor. It automatically shuts the tractor drive OFF when the screw motor reaches a percentage of the motor nameplate full load amperage. As the material clears the screw, the amperage lowers until it reaches a set value and the tractor drive turns back on and moves the screw into the material. The customer must program the set points into the controller and this setup is fully explained in the Owner's manual. We usually start the high set point at approximately 90% of full load amps (FLA) listed on the motor nameplate and the low set point at 60% of the FLA.

Can I use the same control panel for different size sweeps?

If the different size sweeps use the same size motors, the same control panel can be used for different sweeps. The controller must be reprogrammed for each sweep.

Why does the controller need to be located at the bin door?

The control panel **MUST** be mounted **OUTSIDE** the bin near the door for safety reasons. It must be located so the operator has a full view of the equipment. It must **NEVER** be installed inside the bin.

Why do I need a foot switch?

The foot switch has to be plugged into the control panel and depressed before the sweep is operational. It has a 10' cord so the sweep can only be monitored from **OUTSIDE** the bin.

11. Troubleshooting

Can I just run my sweep in the manual mode?

The Series II Sweep is designed to run in the automatic mode. If the sweep is run in the manual mode, either of the motors may overheat and/or become damaged. Also, excessive amounts of material may spill over the back board of the sweep.

How do I set my overloads?

The overloads for both motors are adjustable and are not set at the factory. The overload inside the control panel has a small, usually yellow, dial with numbers on it. Record the full load running amp value listed on the nameplate attached to each motor. Increase the full load amp value by 10% and set this number on the overload dial. If the adjustable overloads are set too low, the motors will shut down as soon as a load is put on them. Disconnect and lock out the power before resetting the motor overloads.

When do I program my controller?

Initially the sweep should be tested in the manual mode. If it operates properly, then move on to try the automatic mode.

How do I program my controller for automatic mode?

The Owner's manual has a detailed set of instructions describing the setup of automatic mode. The final programming must be performed with material in the tank.

Why does not the auger run while tractor drive is in reverse?

This is a safety feature of the Series II Sweep.

Can I get the unit to reverse while in automatic?

No. This is another safety feature of the Series II Sweep.

What do I do if I encounter any operational problems?

Disconnect and lock out the power before servicing the equipment, entering the bin, or resetting the motor overloads. Look through the troubleshooting section to identify any problems.

There does not seem to be any power to my sweep. What do I do?

Check to be sure the foot switch is depressed. The foot switch has a 10' cord so the sweep can only be monitored from OUTSIDE the bin.

The thermal protection cord must be connected before the sweep will operate.

Your electrician should check to make sure there are no loose or shorted connections or wires. It is possible that one of the components failed after it was tested in our plant and needs to be replaced. A jobsite electrician can isolate any malfunctioning components. Each fuse should also be checked and replaced if necessary.

The sweep must be wired according to the Owner/Installation manuals.

The overload for the screw drive keeps tripping. What do I do?

The overloads for both motors are adjustable. These are not set at the factory prior to delivery and installation. The overload inside the control panel has a small, usually yellow, dial with numbers on it. Record the full load running amp value listed on the nameplate attached to each motor. Increase the full load amp value by 10% and set this number on the overload dial. If the adjustable overloads are set too low, the motors will shut down as soon as a load is put on them. Disconnect and lock out the power before resetting the motor overloads.

Check the incoming power at the control box. The Series II Sweep is designed to operate using **460 volt 3 phase 60 cycle power**. The voltage must be within **plus or minus 4%** for proper operation. Voltages outside of this range may cause excessive power draw or other operating problems. Please contact the factory for applications outside of these parameters.

Check the incoming power at the motor. Check for balanced phases. If the loads are not properly balanced between leads, disconnect the motor and check the power leads. By using this method, we can tell if the imbalance is caused by the motor or is from the incoming power.

The sweep must be wired according to the Owner/Installation manuals.

My tractor drive seems to start and stop too often in automatic. What do I do?

The HYS A (High set point minus low set point) may be set with too large a number. To get maximum capacity from the sweep, this number should be set as small as possible and not have grain spill over the sweep backboard.

My controller quits operating. What do I do?

Check to make sure the controller has power. Each of the fuses should be checked and replaced if required.

If the controller is functioning, it may need to be reprogrammed. Programming instructions are included in the manual that shipped with the sweep. The controller can be damaged by large power fluctuations or lightning strikes.

My sweep is not operating as well as it did the last time I used it. What do I do?

If the type of material or the density (moisture) of the material changes, the controller set points may need to be adjusted for maximum output.

Is there any maintenance I need to perform on the electrical system?

None of the electrical components require maintenance. Be sure to disconnect and lock out the power before servicing the equipment, entering the bin, or resetting the motor overloads.

Does any part of the Series II Sweep need lubrication?

The fluid level of each of the gear reducers must be checked before operation. These reducers may have been shipped dry and require oil before operation.

A complete lubrication section is provided in the Owner's manual, which shows the type and amount of lubricant to be used and which components need to be lubricated.

What maintenance should I perform and how often?

Follow the lubrication instructions in the Owner's manual. Also visually inspect the sweep before operation.

11. Troubleshooting

What should I visually inspect?

Starting from the drive end of the sweep:

Inspect the head jack, caster mounting channel and head casters. Look for any bent or damaged components.

Inspect the motor covers. They should be in good shape and should be used properly. If the covers are not used, the material will work its way into the motor cooling slots and when the sweep is started, the motor fan and housing will be destroyed.

Inspect the belt guard for damage. Make sure there is no material inside the belt guard. The drain pan at the bottom of the guard can be used if required.

Inspect the drive belts, sheaves and bushings. Check the belts for proper tension. Sheaves and bushings should be tight.

Inspect the intermediate jacks for any broken or damaged components. Check the jack wheels for damage. The jacks should operate freely.

Inspect each of the screw flight bearings and hangers for damage. Check to see if the bearings need to be replaced. All hardware should be tight.

Inspect the screw flights for damage or excessive wear. Check to see if the screws are rusted or pitted.

Inspect the end bearing for damage.

Inspect the end caster (if one was originally supplied) to confirm it is working properly or if it needs to be replaced.

Inspect the tractor drive chain guard for damage. Make sure there is no material (grain) inside the chain guard. If there is any material (grain), drain pan which is at the bottom of the guard can be used to empty the guard.

Inspect the drive chain for damage and proper lubrication. Check for proper tension and confirm the sprockets and bushings are tight.

Inspect the tractor drive tires for damage or tread wear. Be sure the lug nuts are tight and tires are installed with the tread direction as shown in the manual.

Inspect the bearings for damage or excessive wear. Replace if necessary.

Inspect the tractor drive motor and gear reducer for damage or excessive wear.

Make sure all hardware is tight.

Inspect the sweep structure for damaged or bent components.

- 1. Main Auger Components**
- 2. Flight Components**
- 3. End Bearing Components**
- 4. Auger Drive Components**
- 5. Drive Assembly**
- 6. Tractor Chain Guard Parts**
- 7. Motor Mount Jack and Base Assembly (GC09993)**
- 8. Jack Supports**
- 9. Control Panel Components Pre-June 2010**
- 10. Weight Extension Kit (GC12311)**

Main Auger Components

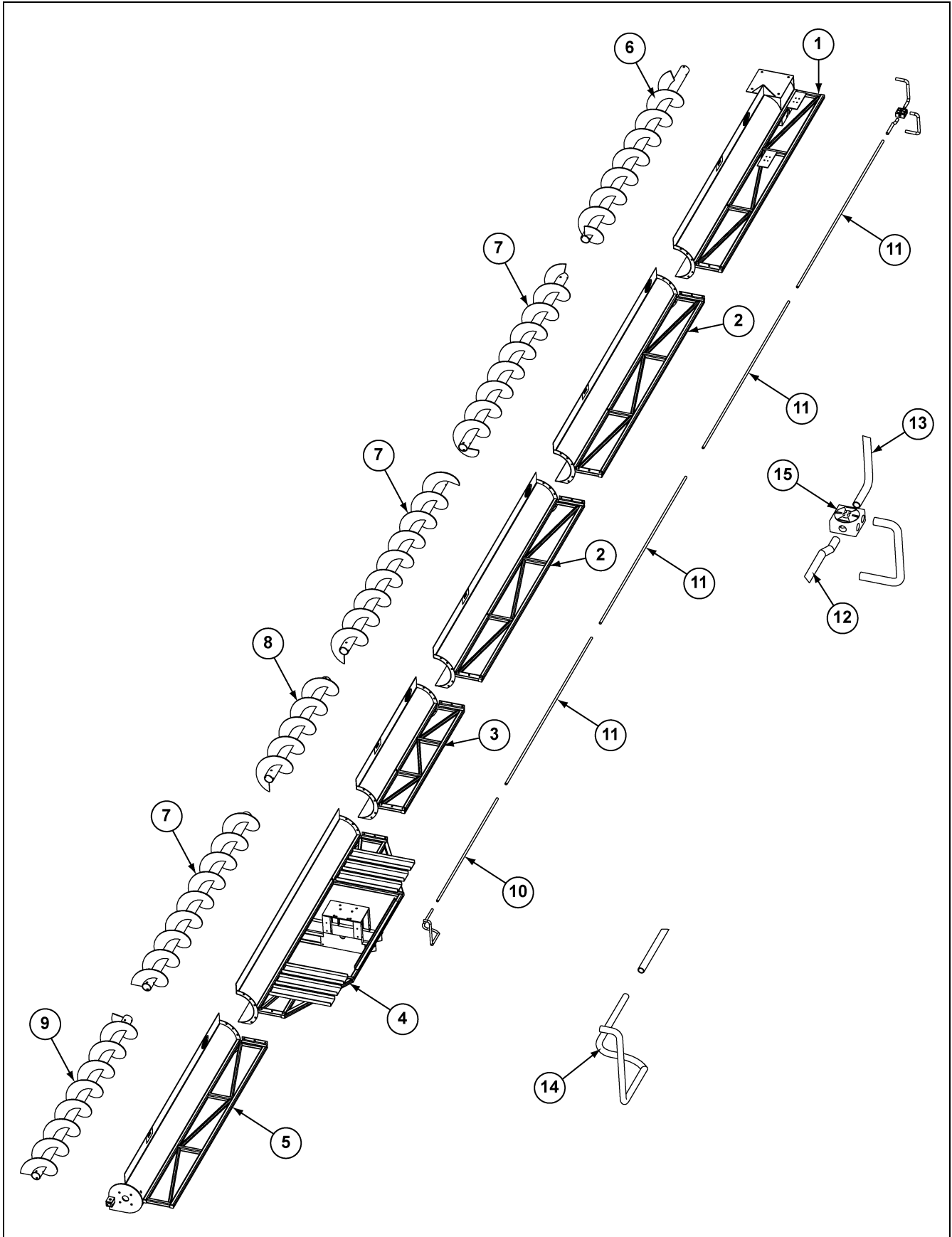

Main Auger Components Parts List

Ref #	Part #	Description
1	GC07078	S2 Sweep Head Section 12" x 144" Pvt
2	GC07068	S2 Sweep Intermediate Section 12" x 144"
3	GC07061	S2 Sweep Intermediate Section 12" x 60"
3	GC07063	S2 Sweep Intermediate Section 12" x 84"
4	GC20013	S2 Sweep Tail Section 12" x Extension
5	GC07272	S2 Sweep Extension Section 12" x 132"
6	GC06465	S2 Sweep Head Flight 12" x 140-3/4"
7	GC06466	S2 Sweep Intermediate/Tail Flight 12" x 142"
8	GC06622	S2 Sweep Intermediate Flight 12" x 58"
8	GC06624	S2 Sweep Intermediate Flight 12" x 82"
9	GC06467	S2 Sweep Extension Flight 12" x 130"
10	GC03798	Conduit 3/4" Rigid x 60"
10	GC06877	Conduit 3/4" Rigid x 84"
11	S-6197	Conduit 3/4" Rigid x 120"
12	GC07523	Conduit 3/4" Flex x 12"
13	GC04862	Conduit 3/4" Flex x 40"
14	GC03800	Conduit 3/4" Flex x 48"
N/S	S-6196	Conduit Coupling x 3/4"
N/S	S-6198	Conduit Coupling Flex x 3/4"
N/S	S-8411	Conduit Clamp 1 Hole ZN 1"
N/S	TFC-0054	Conduit Flex 90° Elbow x 3/4"
N/S	S-8513	Conduit Reducer Bush 1" to 3/4"
N/S	GC07744	Conduit Nipple 1" x 4-3/4"
N/S	1EL0428	Connector Cord (8/4 Cable) 3/4" x 7/8"
N/S	S-4284	Connector Cord (10/4 Cable) 5/8" to 3/4"
N/S	S-4283	Connector Cord (14/4 Cable) 1/4" to 5/8"
15	GC07521	Junction Box-Expl Proof

Flight Components

12" Flight Connection Components

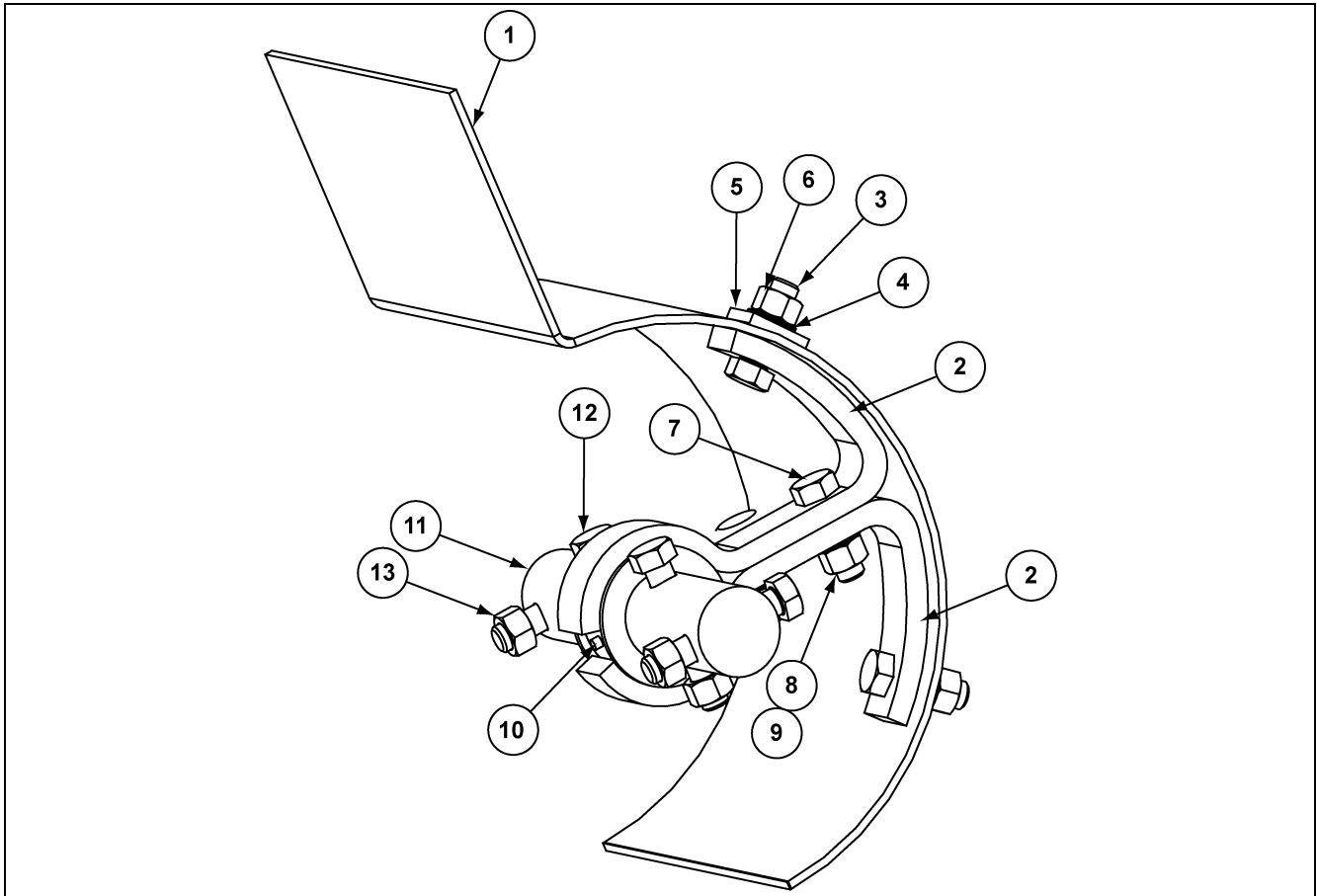

12" Flight Connection Components Parts List

Ref #	Part #	Description	Qty
1		Intermediate Shroud - 3/16" x 12"	N/A
2	GC06000	Hanger Bearing Bracket for 12" Sweep	2
3	S-4329	Bolt, HHCS 5/8"-11 x 2" ZN Grade 8	2
4	S-3208	5/8" Split Lock Washer	2
5	S-8423	Square Flat Washer 11/16" ZN	2
6	S-4110	Hex Nut 5/8"-11 ZN Grade 5	2
7	S-8399	Bolt, HHCS 5/8"-11 x 2" ZN Grade 5	2
8	S-3208	5/8" Split Lock Washer	2
9	S-7597	Hex Nut 5/8"-11 ZN	2
10	GC07701	Nylon Bearing: 2"	2
11	GC03956	2" Coupling Stub	1
12	S-7011	Bolt, HHCS 5/8"-11 x 3-1/2" ZN Grade 8	4
13	S-6494	Lock Nut 5/8"-11 ZN Grade 5 Deformed	4

End Bearing Components

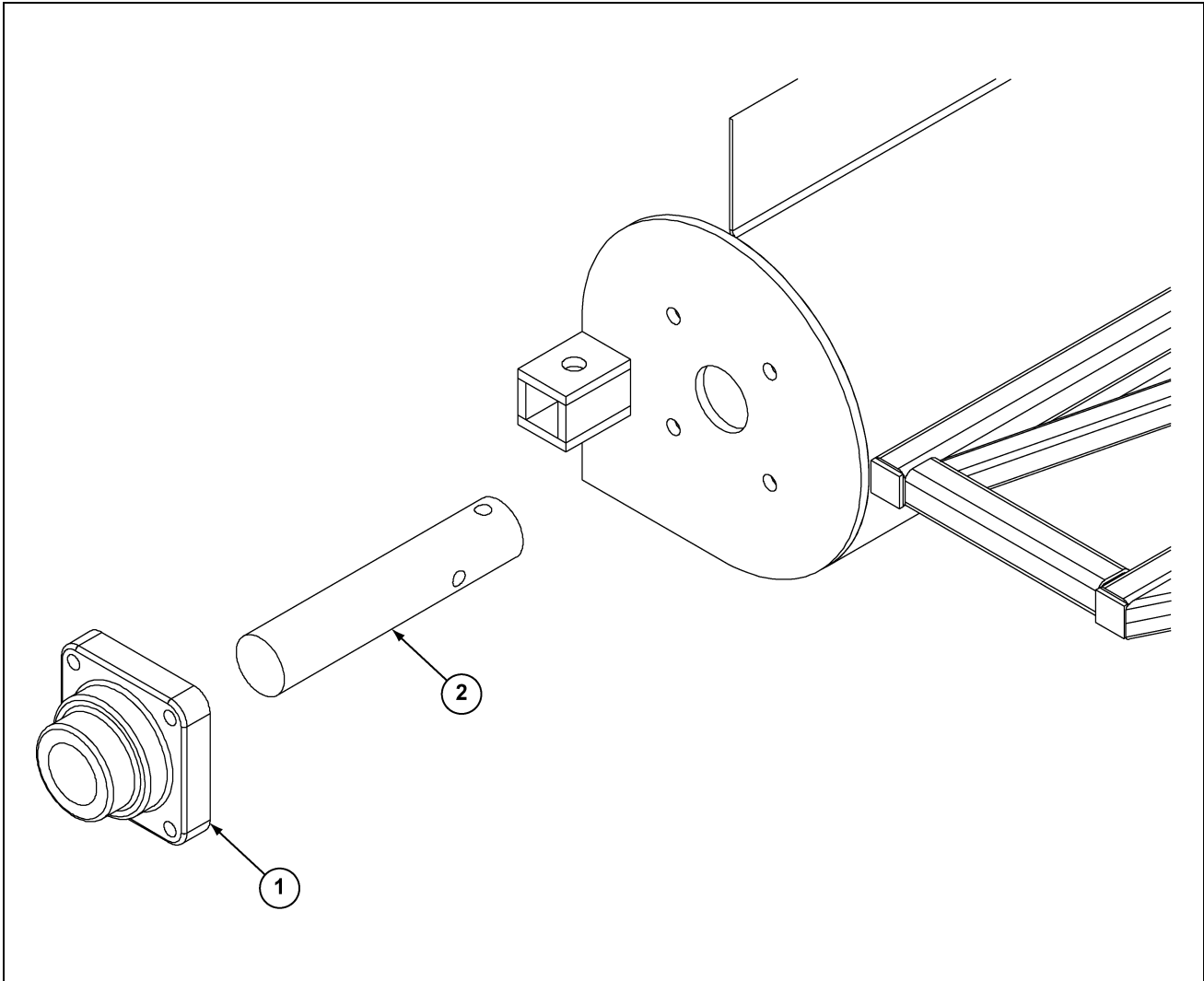

End Bearing Components Parts List

Ref #	Part #	Description
1	KD-PBA0004	Flange Bearing 2" End Cap (12" Sweeps)
2	GC03957	End Stub 2" x 14-7/8" (12" Sweeps)

Auger Drive Components

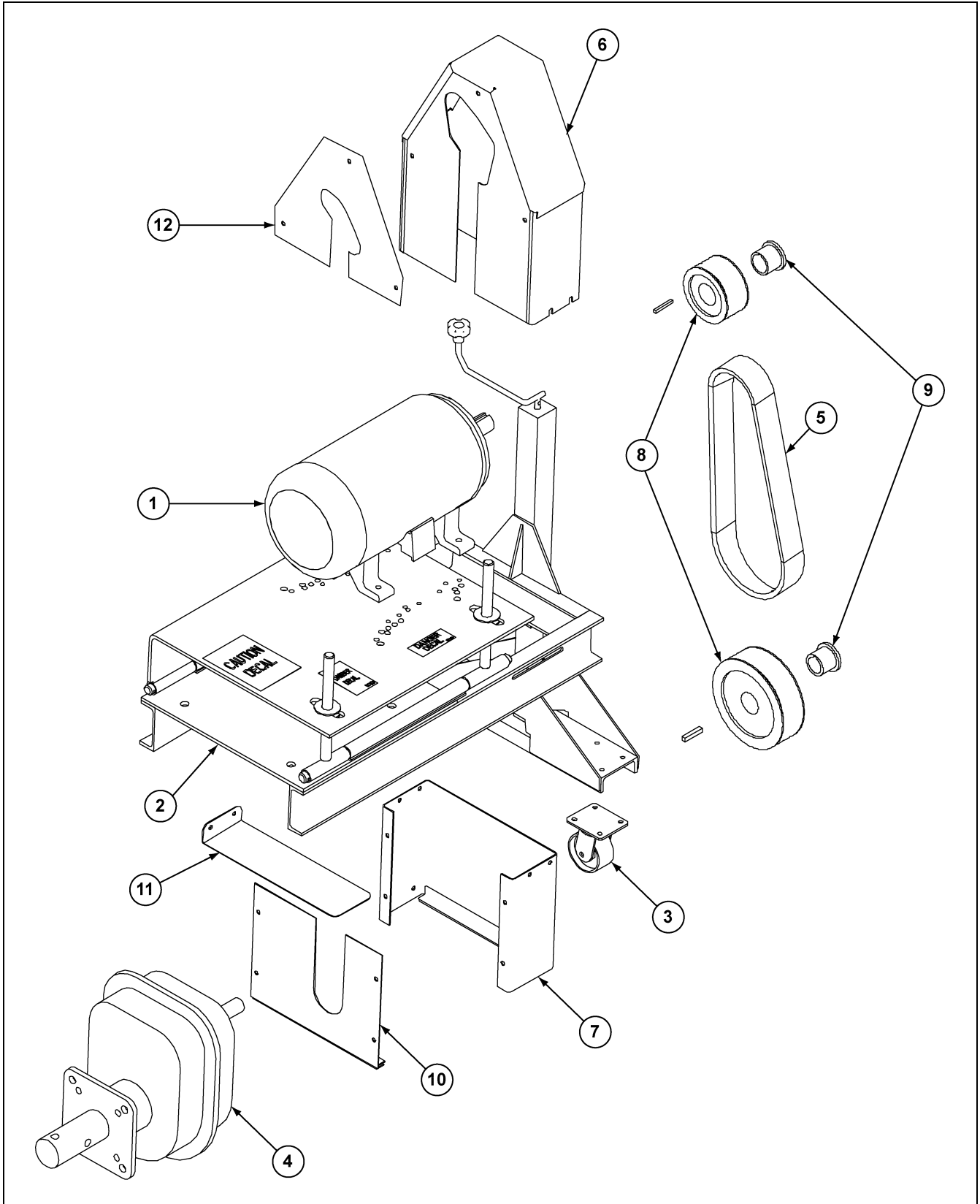

Auger Drive Components Parts List

Ref #	Part #	Description
1	N/A	Motor: XPFC, Class 2 Group F and G
	712-3-XP	7.5 HP - 213T Frame
	MHC60010X	10 HP - 215T Frame
	MHC60015X	15 HP - 254T Frame
	MHC60020X	20 HP - 256T Frame
	MHC60025X	25 HP - 284T Frame
2	GC09993	Motor Mount Assembly w/ Jack
	GC09986	Motor Mount Base Assembly
	GC09992	Motor Jack Assembly
3	GC03436	Swivel Caster 1-1/2" x 4"
4	N/A	Reducer: w/ CEMA Adapter and Output Shaft
	GC11363	115SMTP05-2"
	GC09809	115SMTP09-2"
	GC11364	203SMTP05-2"
	GC09587	203SMTP09-2"
	GC11597	207SMTP09-2"
	GC09810	115SMTP09-3"
	GC09588	203SMTP09-3"
	GC09589	207SMTP09-3"
	GC09591	215SMTP09-3"
5	N/A	Belt
6	GC09770	Belt Guard Assembly, Top
7	GC09764	Belt Guard Assembly, Bottom
8	N/A	Sprocket
9	N/A	Bushing
N/S	GC03654	Motor Cover 39" x 35" x 20"
10	GC09762	Belt Guard Bottom Back Plate
11	GC09759	Belt Guard Bottom Pan
12	N/A	Belt Guard Motor Specific Plate
	GC09875	184T Frame
	GC09876	213/215T Frames
	GC09877	254/256T Frames
	GC09878	284/286T Frames
	GC09879	324T Frame

Drive Assembly

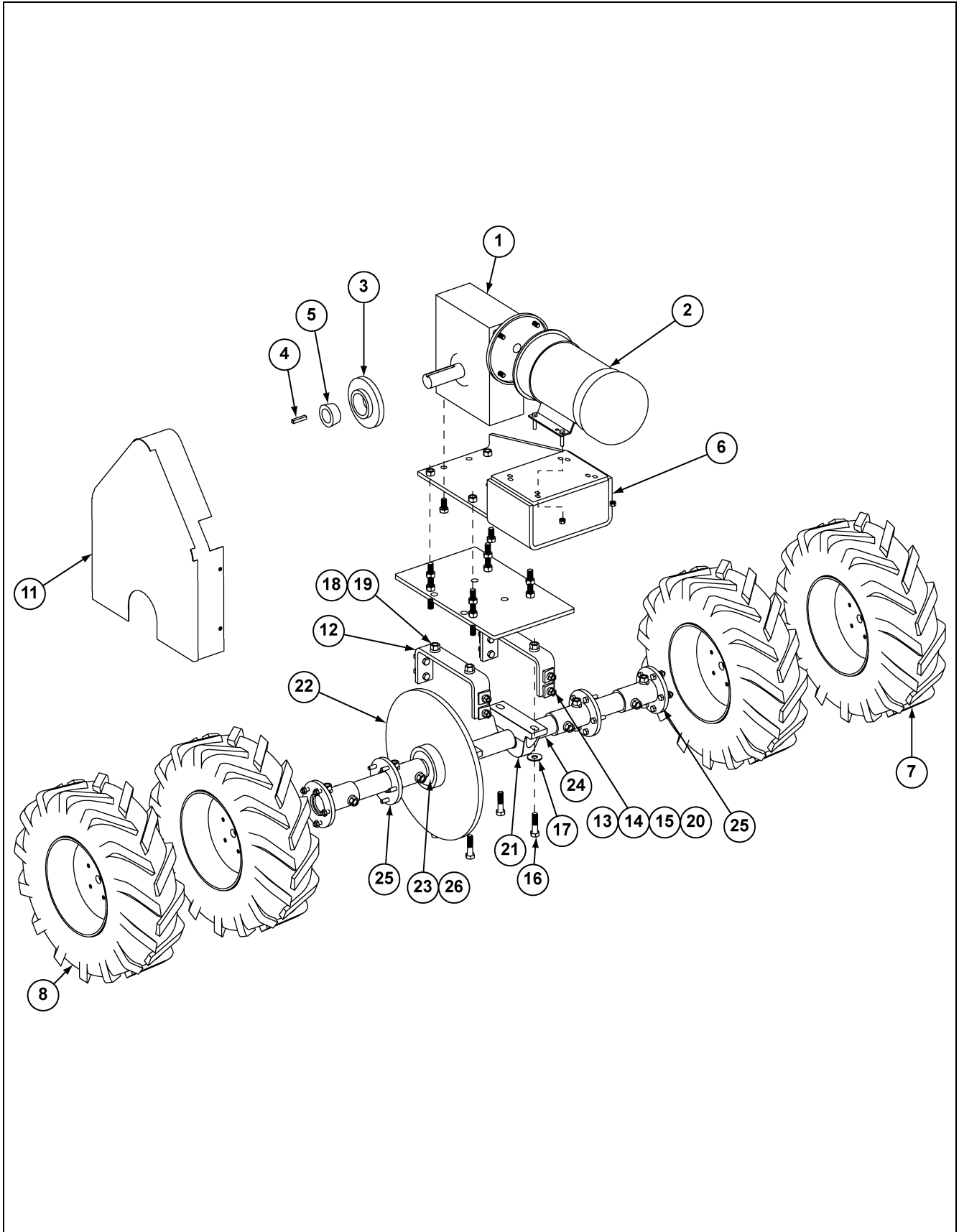

Drive Assembly Parts List

Ref #	Part #	Description	Qty
1	GC12273	Reducer, 524 Model, 50:1 Style B, 182TC Frame	1
2	GC09932	Motor: XPFC, Class 2 Group F and G, 5 HP 1760 RPM 460/3/60 184TC Frame w/ Feet (380V Only)	1
3	GC12268	Sprocket, #100 14 Tooth	1
4	S-9180	Square Key, 3/8" x 2"	1
5	GC12270	Bushing, 1-3/4" 2012 Taper Lock	1
6	GC12263	S2 Sweep Tractor Drive Motor Mount 182TC	1
7	GC03476	Tire, Mounted, 12-8 x 23" Right Hand Tractor Tread-Foam Filled	2
8	GC06508	Tire, Mounted, 12-8 x 23" Left Hand Tractor Tread-Foam Filled	2
N/S	GC12208	175 lbs. Counterweight	12
N/S	GC12272	Drive Axle Assembly - Bolt on Hubs (N/S)	1
11	GC12255	Top Chain Guard Assembly	1
12	GC12283	Bearing Support Bracket	2
13	S-3883	Bolt, HHCS 1/2"-13 x 1-3/4"	8
14	S-236	1/2" Split Lock Washer ZN	8
15	S-3729	Hex Nut 1/2"-13 ZN YDP Grade 5	8
16	S-8429	Bolt, HHCS 5/8"-11 x 2-1/2"	4
17	S-858	Flat Washer 5/8"	4
18	S-3208	5/8" Split Lock Washer	4
19	S-4110	Hex Nut 5/8"-11 ZN Grade 5	4
20	S-9242	5/8" Beveled Washer	4
21	GC12279	Bearing, Pillow Block, 2-1/4" I.D.	2
22	GC12267	Sprocket, #100 45 Tooth for Axle	1
23	GC12269	Bushing, 2-1/4" 3020 Taper Lock	1
24	GC12271	Bolt-On Drive Axle	1
25	GC12282	Bolt-On Hub Assembly	4
26	GC03811	Square Key, 1/2" x 2-1/4"	1
N/S	GC12274	Roller Chain #80 x 71"	1
N/S	GC11777	Connecting Link #80	1
N/S	GC11778	Offset Link #80	1
N/S	GC03653	Motor Cover 57" x 35" x 20"	1

Tractor Chain Guard Parts

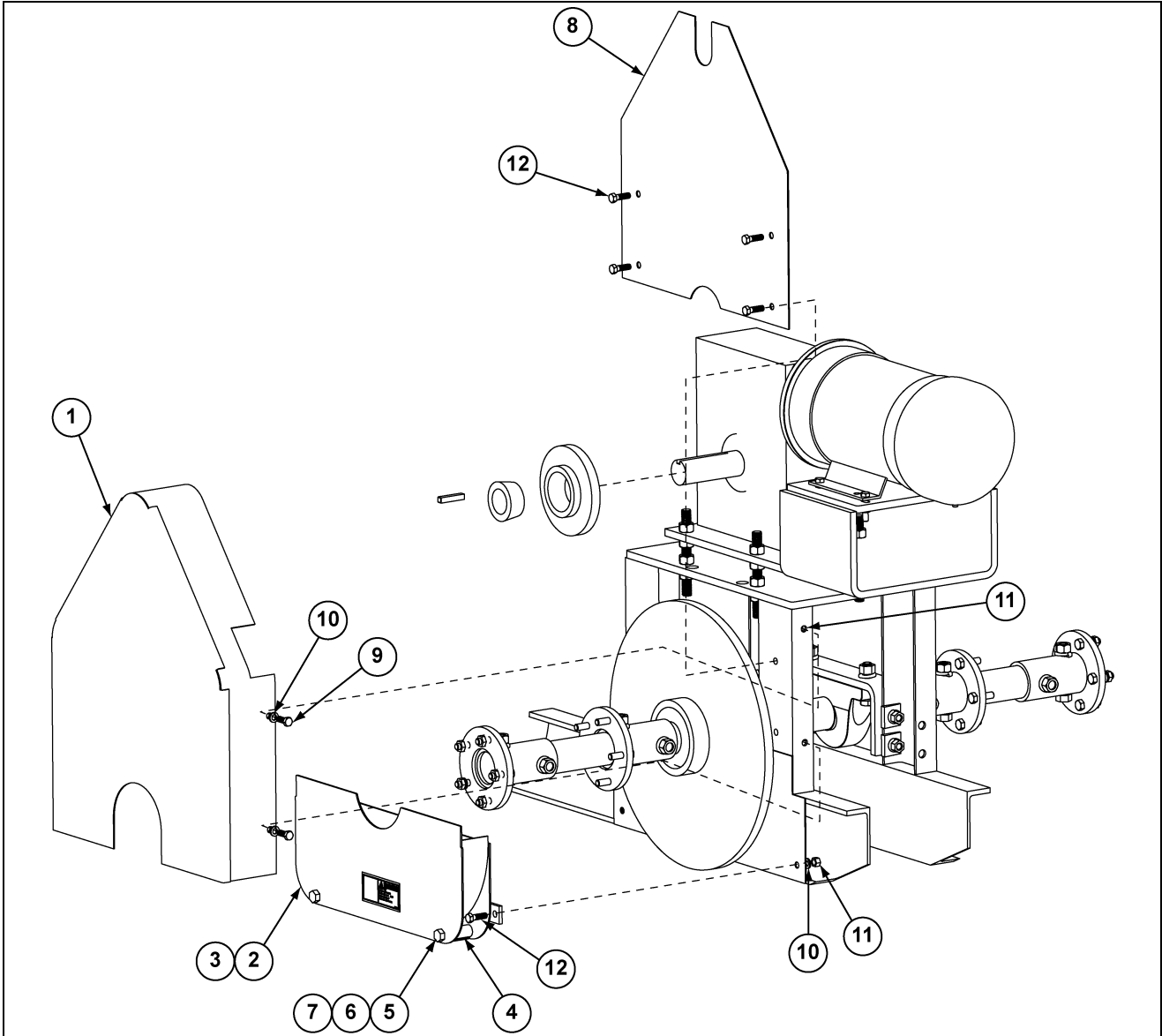

Tractor Chain Guard Parts List

Ref #	Part #	Description	Qty
1	GC12255	Top Chain Guard Assembly	1
2	GC12276	Bottom Chain Guard Assembly	1
3	GC12277	Bottom Chain Guard Weldment	1
4	GC10047	Bottom Chain Guard Trap	1
5	S-236	1/2" Split Lock Washer ZN	2
6	S-3729	Hex Nut 1/2"-13 ZN YDP Grade 5	2
7	S-7722	Bolt, 1/2"-13 x 3"	2
8	GC10035	Guard Plate	1
9	S-7469	Bolt, HHCS 3/8"-16 x 1"	4
10	S-1054	3/8" Split Lock Washer Zinc	10
11	S-456	3/8"-16 Hex Nut Zinc YDP Grade 5	10
12	S-2071	Bolt, HHCS 3/8"-16 x 1-1/4"	6

Motor Mount Jack and Base Assembly (GC09993)

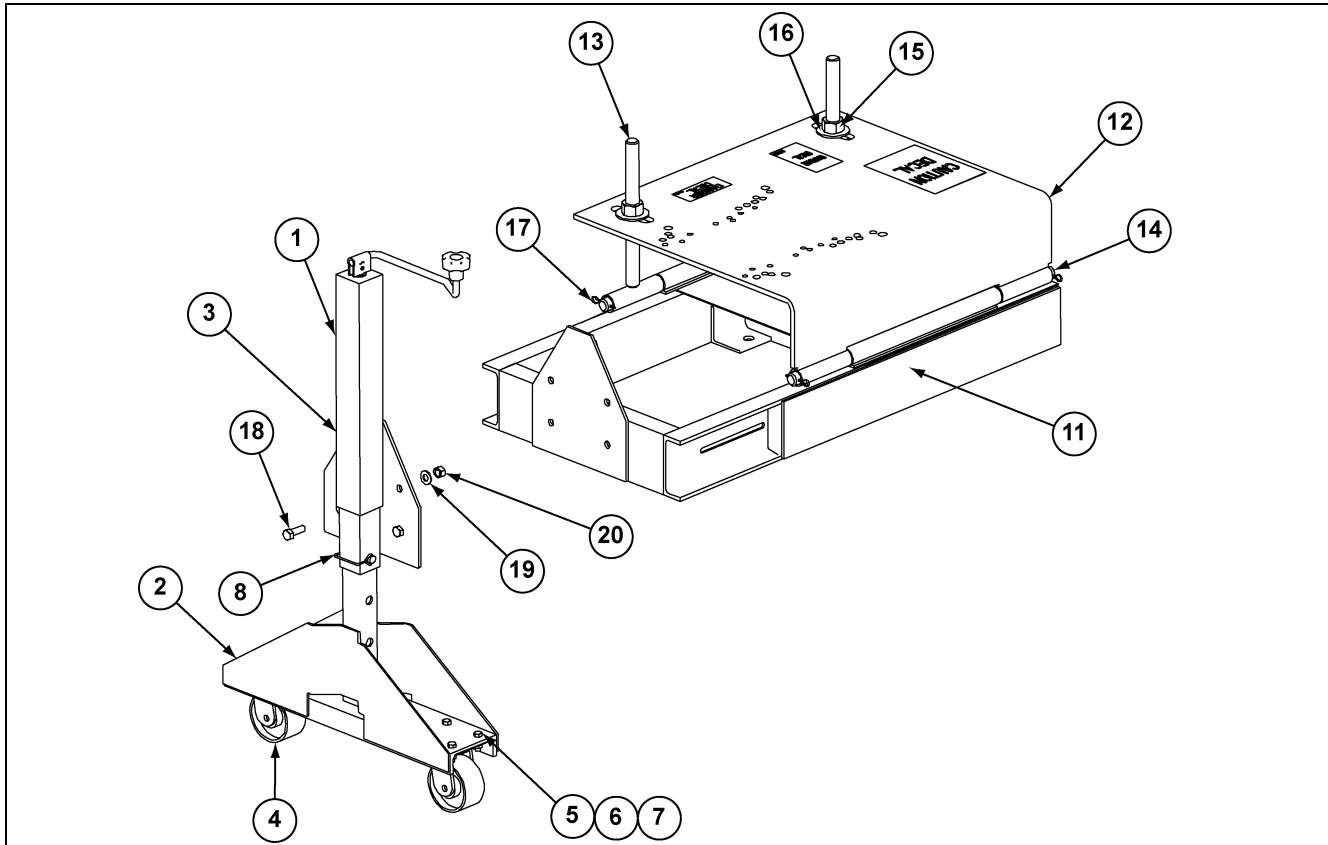

Motor Jack Assembly (GC09992)			
Ref #	Part #	Description	Qty
1	GC09991	Jack Housing Assembly	1
2	GC09479	Jack/Caster Mount Base	1
3	GC10461	Jack-w/o Outer Housing	1
4	GC03436	Swivel Caster 1-1/2" x 4"	2
5	S-1054	3/8" Split Lock Washer Zinc	8
6	S-2071	Bolt, HHCS 3/8"-16 x 1-1/4"	8
7	S-456	3/8"-16 Hex Nut Zinc YDP Grade 5	8
8	S-8441	Jack Clevis Pin	1

Motor Mount Base Assembly (GC09986)			
Ref #	Part #	Description	Qty
11	GC09984	Frame Weldment	1
12	GC09756	Top Plate Assembly	1
13	GC09755	Adjuster Assembly	2
14	GC09757	Pivot Shaft	2
15	S-240	Hex Nut, 1"-8	4
16	S-7835	Flat Washer, 1"	4
17	S-7241	Cotter Pin, 1/8" x 1-1/4"	4
18	S-8760	Bolt, 1/2"-13 x 1-1/2"	4
19	S-2120	Flat Washer, 1/2"	4
20	S-3729	Hex Nut 1/2"-13 ZN YDP Grade 5	4

Jack Supports

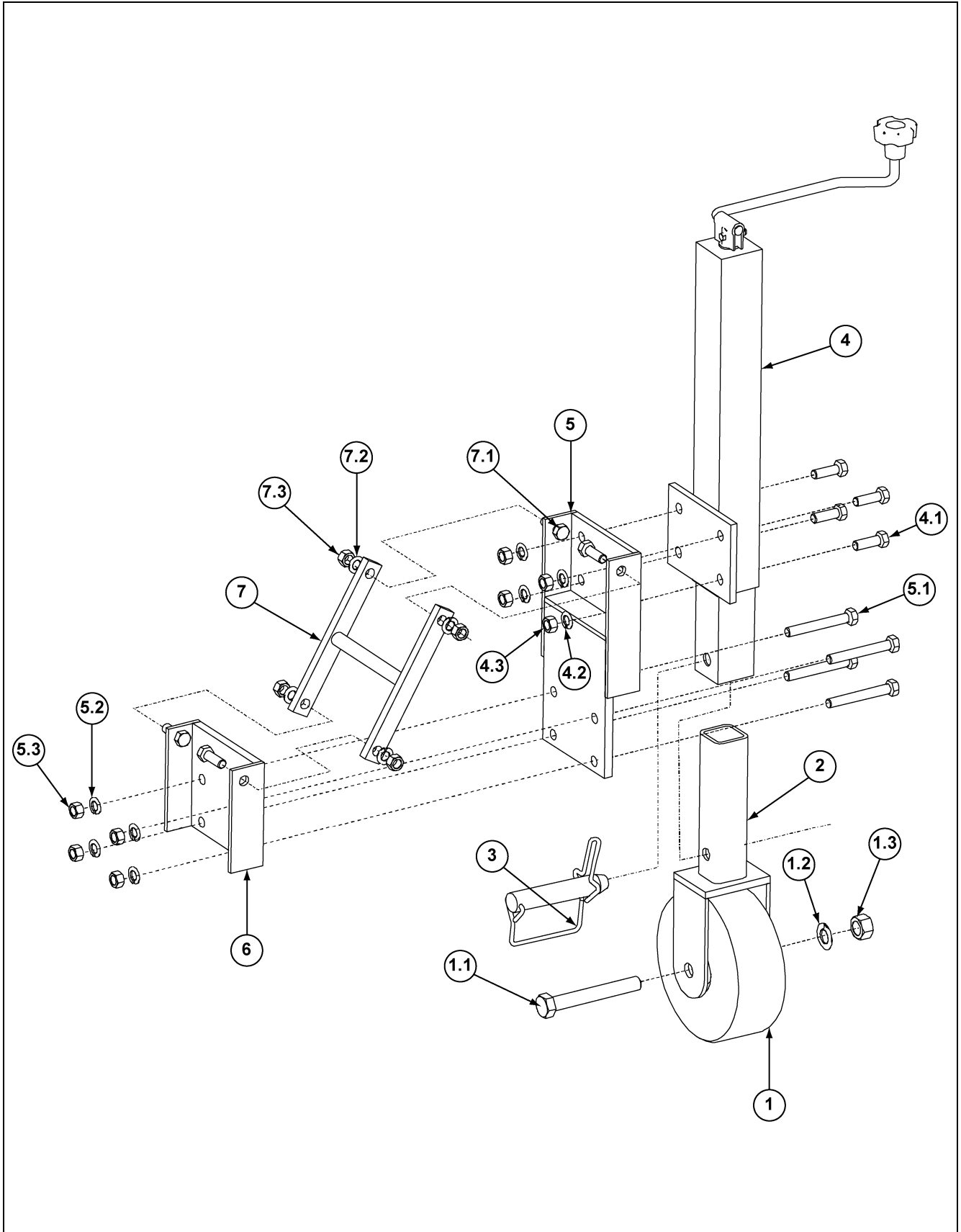

Jack Supports Parts List

Ref #	Part #	Description	Qty
1	GC06974	Caster Wheel 3" x 8" Diameter x 3/4" Axle	1
1.1	S-6638	Bolt, HHCS 3/4"-10 x 5-1/2" ZN Grade 8	1
1.2	S-233	Split Lock Washer, 3/4" ZN	1
1.3	S-234	Hex Nut, 3/4"-10 ZN Grade 5	1
2	GC08507	S2 Sweep Jack Caster Assembly	1
3	S-8441	Jack Clevis Pin	1
4	GC07934	S2 Sweep 7000# Jack Assembly	1
4.1	S-7528	Bolt, HHCS 1/2"-13 x 1-1/2" ZN Grade 5	4
4.2	S-236	1/2" Split Lock Washer ZN	4
4.3	S-7510	1/2"-13 Hex Nut Zinc Grade 2	4
5	GC07839	Jack Mount Assembly	1
5.1	S-8400	Bolt, HHCS 1/2"-13 x 3-3/4" ZN Grade 5	4
5.2	S-236	1/2" Split Lock Washer ZN	4
5.3	S-7510	1/2"-13 Hex Nut Zinc Grade 2	4
6	GC07926	S2 Sweep Jack Mount Plate Assembly	1
7	GC07931	S2 Sweep Jack Truss Assembly - 12"	1
7.1	S-7528	Bolt, HHCS 1/2"-13 x 1-1/2" ZN Grade 5	4
7.2	S-236	1/2" Split Lock Washer ZN	4
7.3	S-7510	1/2"-13 Hex Nut Zinc Grade 2	4
N/S	GC08627	BOP: Jack Kit (Contains all above parts less wheel)	1

Control Panel Components Pre-June 2010

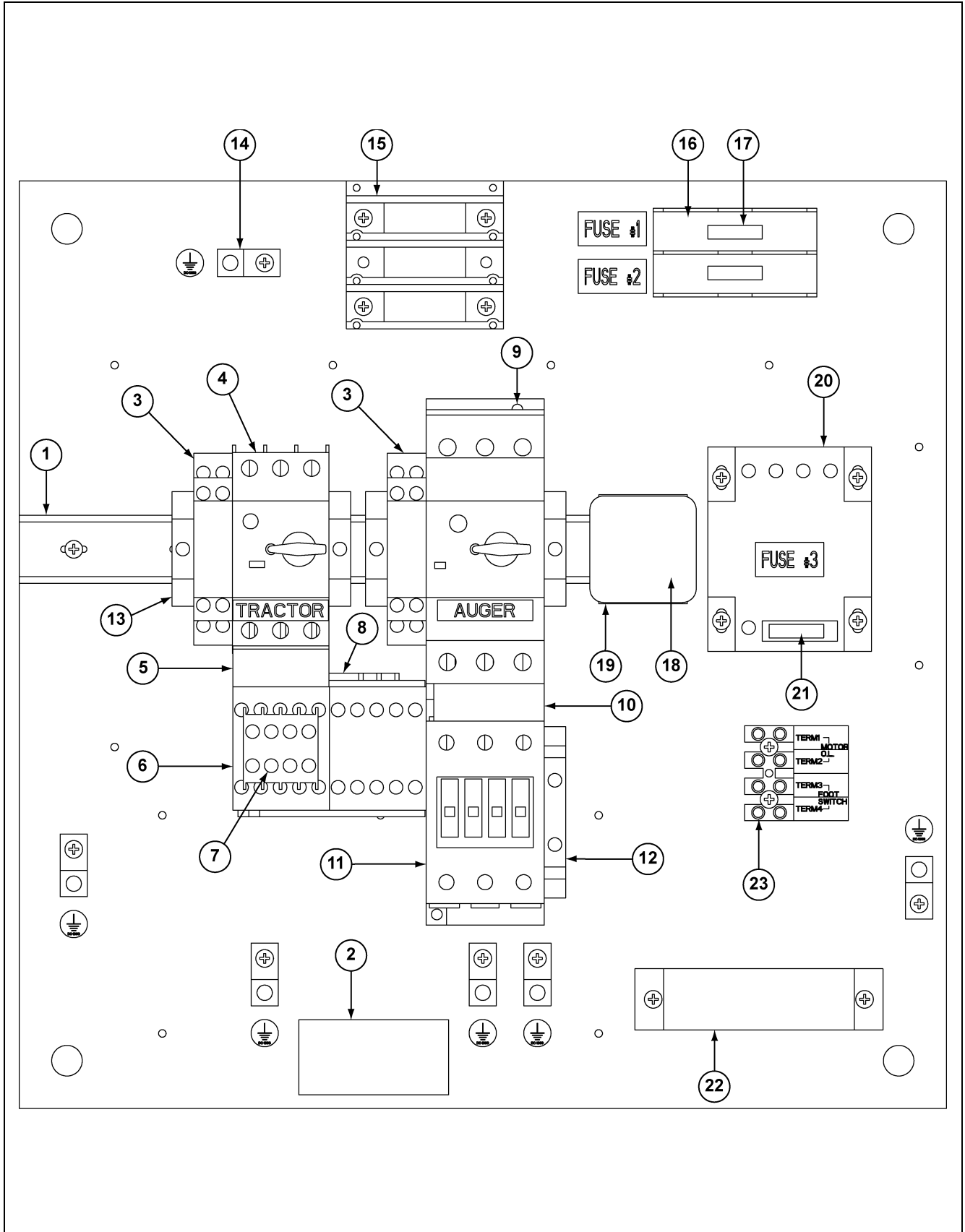

Control Panel Components Pre-June 2010 Parts List

Ref #	Part #	Description
1	GC06993	Din Rail 12.375"
2	DC-889	Decal, Danger High Voltage
3	756-1953-6	Switch-Bell Alarm Integrated
4	756-1977-5	Protector, Motor Starter, 5.5-8A, Int
5	756-1947-8	Bracket-Link, up to 10 Amp
6	756-1976-7	Relay-9 Amp Integrated
7	GT3-896	Mount-Contact, Auxiliary, 1 N.O./N.C.
8	756-2006-2	Starter-Reversing Kit, Integrated
9	756-1991-6	Protector, Motor Starter, 18-25 Amp, Int
10	756-1949-4	Bracket-Link S2, up to 50 Amp
11	756-2001-3	Contacto S2 28 Amp, Integrated
12	GT3-1002	Mount-Contact, Auxiliary, 1 N.O./N.C., Side
13	D01-0533	Din Rail End Stop
14	E160-1137	Ground Lug
15	C-8018	3 Pole Power Distribution Block
16	GC03676	Fuse Block 2 Pole
17	GC03677	Fuse, 600V Midget TD 1/4 Amp
18	GC07510	AC Current Transducer Socket
19	GC07509	AC Current Transducer
20	GC03673	Transformer, 50 VA 50/60 Hz, 230/380/460
21	GC03679	Fuse, 250V Midget TD 6/10 Amp
22	GC07511	Current Transformer 50:5 Amp
23	S-7605	Terminal Block

Control Panel Components Pre-June 2010 (Continued)

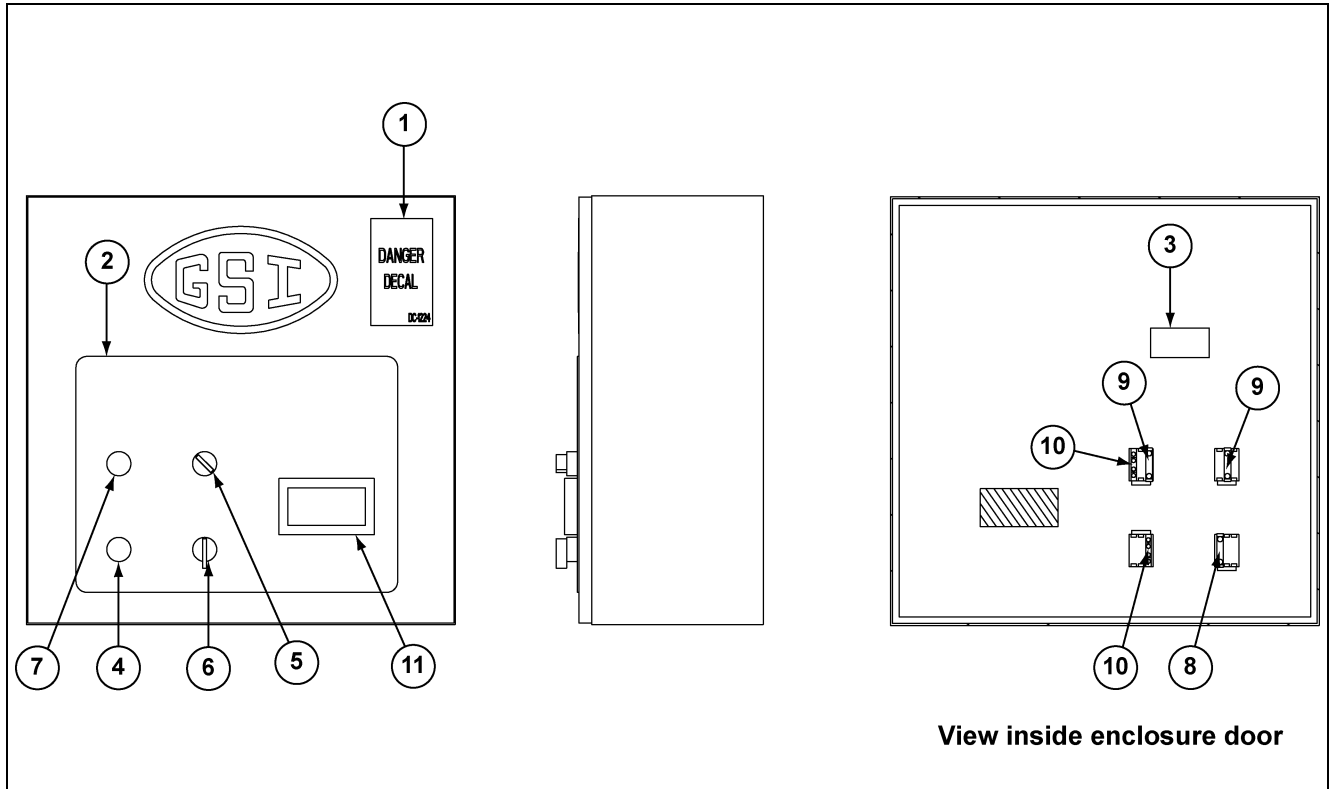

Control Panel Components Pre-June 2010 Parts List

Ref #	Part #	Description
1	DC-1224	Decal, Danger High Voltage
2	DC-1536	Decal, Series II Sweep Panel Overlay
3	DC-889	Decal, Danger High Voltage
4	GC03659	Standard-Round-Push Button-Plastic-Flush-Red
5	GC06956	2 Position - Maint - Plastic - Black
6	GC06957	3 Position - Lever - SL - SW - Momentary
7	GC06958	Standard-Round-Push Button-Plastic-Flush-Green
8	D63-0013	Cnt Blck/1 N.C./SCR
9	D63-0006	Cnt Blck/1 N.O./SCR
10	GC06961	Cnt Blck/SCR
11	GC07585	Series II Sweep Amp Meter
N/S	GC06857	Series II Sweep Safety Foot Switch Assembly

Weight Extension Kit (GC12311)

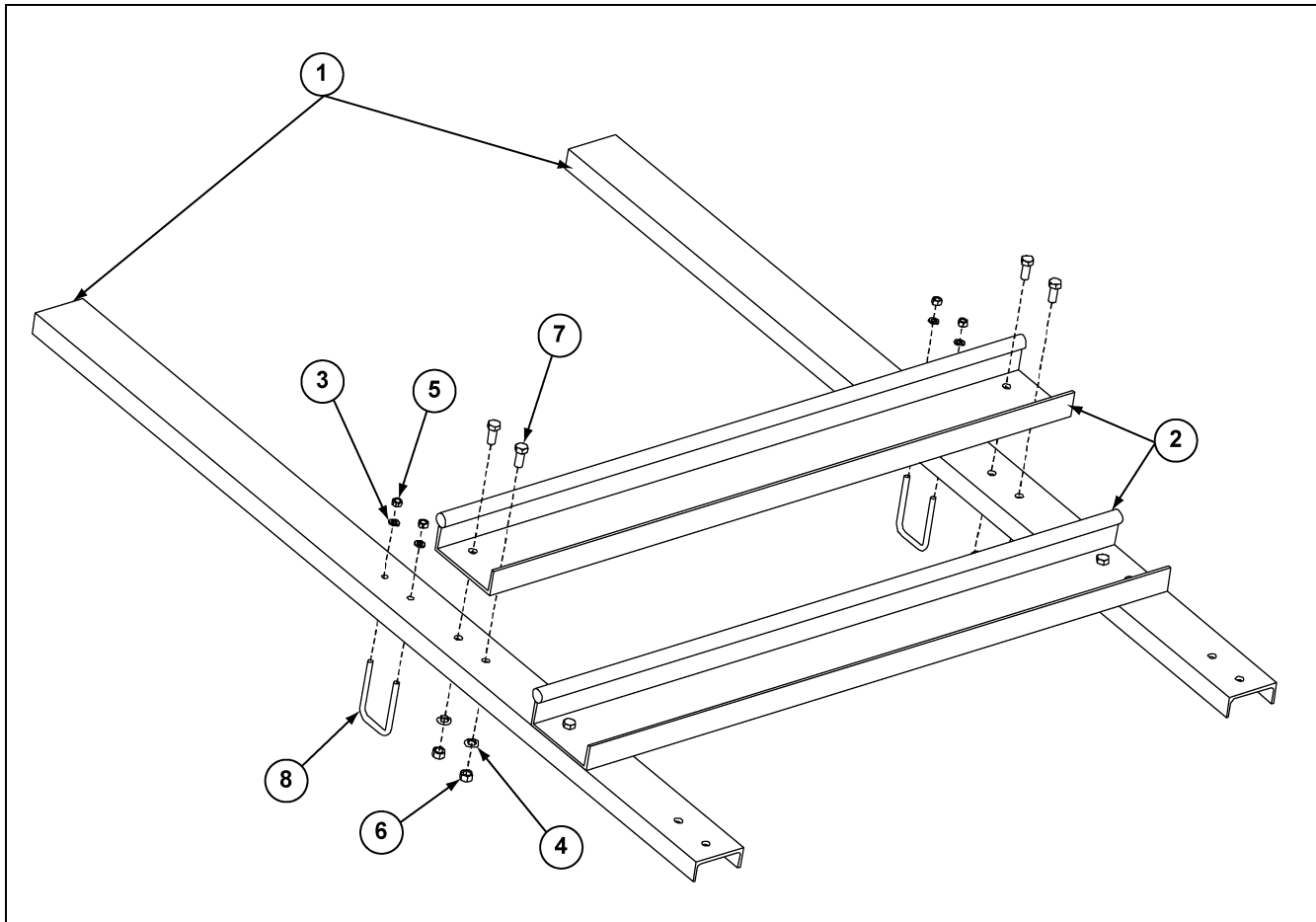

Weight Extension Kit (GC12311) Parts List

Ref #	Part #	Description
1	GC08141	S2 Sweep Adjustable Center Weight Channel
2	GC12310	S2 Sweep Center Weight Channel Weldment
3	S-1054	3/8" Split Lock Washer Zinc
4	S-236	1/2" Split Lock Washer ZN
5	S-456	3/8"-16 Hex Nut Zinc YDP Grade 5
6	S-7510	1/2"-13 Hex Nut Zinc Grade 2
7	S-7534	1/2"-13 x 1-1/4" HHCS Bolt Zinc Grade 5
8	S-8666	3/8"-16 x 2-7/16" U-Bolt Zinc
N/S	GC12208	Counterweight Long Version

NOTES

GSI Group, LLC Limited Warranty

The GSI Group, LLC ("GSI") warrants products which it manufactures to be free of defects in materials and workmanship under normal usage and conditions for a period of 12 months after sale to the original end-user or if a foreign sale, 14 months from arrival at port of discharge, whichever is earlier. The end-user's sole remedy (and GSI's only obligation) is to repair or replace, at GSI's option and expense, products that in GSI's judgment, contain a material defect in materials or workmanship. Expenses incurred by or on behalf of the end-user without prior written authorization from the GSI Warranty Group shall be the sole responsibility of the end-user.

Warranty Extensions:

The Limited Warranty period is extended for the following products:

	Product	Warranty Period	
AP Fans and Flooring	Performer Series Direct Drive Fan Motor	3 Years	* Warranty prorated from list price: 0 to 3 years - no cost to end-user 3 to 5 years - end-user pays 25% 5 to 7 years - end-user pays 50% 7 to 10 years - end-user pays 75%
	All Fiberglass Housings	Lifetime	
	All Fiberglass Propellers	Lifetime	
Cumberland Feeding/Watering Systems	Feeder System Pan Assemblies	5 Years **	** Warranty prorated from list price: 0 to 3 years - no cost to end-user 3 to 5 years - end-user pays 50%
	Feed Tubes (1-3/4" and 2.00")	10 Years *	
	Centerless Augers	10 Years *	
	Watering Nipples	10 Years *	
Grain Systems	Grain Bin Structural Design	5 Years	† Motors, burner components and moving parts not included. Portable dryer screens included. Tower dryer screens not included.
Grain Systems Farm Fans Zimmerman	Portable and Tower Dryers	2 Years	
	Portable and Tower Dryer Frames and Internal Infrastructure †	5 Years	

GSI further warrants that the portable and tower dryer frame and basket, excluding all auger and auger drive components, shall be free from defects in materials for a period of time beginning on the twelfth (12th) month from the date of purchase and continuing until the sixtieth (60th) month from the date of purchase (extended warranty period). During the extended warranty period, GSI will replace the frame or basket components that prove to be defective under normal conditions of use without charge, excluding the labor, transportation, and/or shipping costs incurred in the performance of this extended warranty.

Conditions and Limitations:

THERE ARE NO WARRANTIES THAT EXTEND BEYOND THE LIMITED WARRANTY DESCRIPTION SET FORTH ABOVE. SPECIFICALLY, GSI MAKES NO FURTHER WARRANTY OF ANY KIND, EXPRESS OR IMPLIED, INCLUDING, WITHOUT LIMITATION, WARRANTIES OF MERCHANTABILITY OR FITNESS FOR A PARTICULAR PURPOSE OR USE IN CONNECTION WITH: (I) PRODUCT MANUFACTURED OR SOLD BY GSI OR (II) ANY ADVICE, INSTRUCTION, RECOMMENDATION OR SUGGESTION PROVIDED BY AN AGENT, REPRESENTATIVE OR EMPLOYEE OF GSI REGARDING OR RELATED TO THE CONFIGURATION, INSTALLATION, LAYOUT, SUITABILITY FOR A PARTICULAR PURPOSE, OR DESIGN OF SUCH PRODUCTS.

GSI shall not be liable for any direct, indirect, incidental or consequential damages, including, without limitation, loss of anticipated profits or benefits. The sole and exclusive remedy is set forth in the Limited Warranty, which shall not exceed the amount paid for the product purchased. This warranty is not transferable and applies only to the original end-user. GSI shall have no obligation or responsibility for any representations or warranties made by or on behalf of any dealer, agent or distributor.

GSI assumes no responsibility for claims resulting from construction defects or unauthorized modifications to products which it manufactured. Modifications to products not specifically delineated in the manual accompanying the equipment at initial sale will void the Limited Warranty.

This Limited Warranty shall not extend to products or parts which have been damaged by negligent use, misuse, alteration, accident or which have been improperly/inadequately maintained. This Limited Warranty extends solely to products manufactured by GSI.

Prior to installation, the end-user has the responsibility to comply with federal, state and local codes which apply to the location and installation of products manufactured or sold by GSI.

This equipment shall be installed in accordance with the current installation codes and applicable regulations which should be carefully followed in all cases. Authorities having jurisdiction should be consulted before installations are made.

G S I G R O U P



GSI Group
1004 E. Illinois St.
Assumption, IL 62510-0020
Phone: 1-217-226-4421
Fax: 1-217-226-4420
www.gsiag.com